

REQ23/24

REQUISITION FORM FY23/24

DATE PREPARED: 04/25/2024

REQ. CONTACT PERSON: Gerald Bailey / Randy Loock

REASON: 2024 E450 Mobile Medical Exam Clinic

VENDOR # OR NAME TESCO specialty vehicles (TSV)

CONTACT & TEL Ben Connors ph:419-720-7433 fax: 419-836-8460

EMAIL ADDRESS: bconnors@tescobus.com

VENDOR ADDRESS: 5434 Navarre Ave. PO box 167230 Oregon OH. 43616

SHIP TO: PW-WC-LA-ET (CIRCLE ONE)

DELIVER BY DATE: 9/30/2024

ITEM DESCRIPTION:

LINE #1: Sole Source Purchase (1) 2024 E450 Mobile Medical Clinic

(See attached specifications and quote)

QTY.: 1.0

ORDER UOM: Each

UNIT COST: \$ 238,900.00

TOTAL REQ. AMT. \$ 238,900.00

ACCOUNT# 138.36.3613.569.64.00 Project #3243601.

APPROVED:  4-30-24
ASST. PW DIRECTOR DATE

CAPITAL OUTLAY # _____

APPROVED: _____
DIRECTOR DATE

FISCAL ASST: _____
DATE

COMMENTS:

Color: White
Additional E450 Mobile Med unit **Quote# NQ59578-1**
(See attached options)

January 5, 2024

David Lykens
Rescue Lieutenant
Alachua County Fire Rescue
15040 NW US HWY 441
Alachua FL 32615

Mr Lykens:

Thank you for the opportunity to provide a mobile clinic to your organization. This letter is to provide a justification for sole source procurement.

Historically mobile clinics such as the vehicle you are considering have been custom built from the ground up. TESCO Specialty Vehicles (TSV) has revolutionized the industry by developing a standardized vehicle platform based on a bus body shell.

Our products are developed by building a steel cage body shell on a Ford E-Series cutaway chassis. This steel cage is built to FMVSS standards for bus bodies. There are no other known manufacturers that build mobile clinics in the same manner. All other known mobile clinic manufacturers start with either a cargo box body or a consumer based recreational vehicle body. Our vehicle, being built using a bus body, is in a completely different class than the cargo box or consumer based recreational vehicle body based mobile clinics. This is the primary reason that there is no other vehicle in the industry to compare with our proposed vehicle.

Attached to this letter is our body cage construction drawings which show the unique bus body shell design.

We appreciate the opportunity to work with you on this procurement. Should you have questions please feel free to reach out to Ben Connors at bconnors@tescobus.com , 419-720-7433 or myself at jpappas@tescobus.com or 419-720-7451.

Sincerely,



Jeff Pappas
TESCO Vice-President

4/12/2024

Ben Connors p 419-720-7433
 bconnors@tescobus.com f 419.836.8460

5434 Navarre Ave www.tescosv.com
 P.O. Box 167230 855.376.9797
 Oregon OH 43616

Alachua County Fire Rescue

15040 NW US HWY 441
 Alachua FL 32615

David Lykens
 407-257-9575
 dlykens@alachuacounty.us

Qty: 1



Picture is from a similar vehicle

**2024 Exam Room & Blood Draw
 Mobile Clinic ADA
 with a 2024 Ford E450
 1 passenger & driver**

Engine: 7.3L
 Wheelbase: 158
 GVWR: 14500

Standard Chassis Equipment

- Ford E-450 7.3L V8 Gas Engine
- 14,500 GVWR
- 6 Speed Automatic Transmission
- 225/75RX16E Tires
- 50 State Emissions
- Cruise Control
- Dual Batteries
- 55 Gallon Fuel Tank
- Daytime Running Lights
- AM/FM/USB Radio with 4 Speakers

Standard Body Equipment

- Welded Tubular Steel Cage
- Drive Shaft Guards
- Rear Mud Flaps
- Steel Cage Primered w/Rust Inhibitor
- Underbody Foam Sealed and Undercoated
- 3/4" Coosa Composite Subfloor
- Fiberglass Flat Vertical Sidewalls
- White Fiberglass Gel Coat Exterior
- 1' Polystyrene Foam Board Insulation
- Tinted A-Panel Window in Cab
- LED Interior and Exterior Lighting
- Heavy-Duty Steel Powder-Coated Rear Bumper
- Velvac Exterior Manual Mirrors (L & R) on Terra Transit

Body and Chassis Standard Equipment is subject to change without notice and may be replaced by Options Included on next page.

4/12/2024

Ben Connors p 419-720-7433
 bconnors@tescobus.com f 419.836.8460

Alachua County Fire Rescue

15040 NW US HWY 441
 Alachua FL 32615

David Lykens
 407-257-9575
 dlykens@alachuacounty.us

5434 Navarre Ave www.tescosv.com
 P.O. Box 167230 855.376.9797
 Oregon OH 43616

Options Included

Additional Chassis Equipment

Full Wheel Alignment - Castor & Camber

Additional Equipment

LED Light Strip for upper cabinets
 (2) Floor Wall Heater 1000W 120V
 (2) Smoke/Carbon Detector
 (2) Trash Can

Additional Installed Options

(2) Curtain Hold Back Strap
 Wheel Liners Stainless Steel E350/450 w/Valve Ext.
 (2) Storage Compartment Lock 1 3/8" Keyed
 Curtain Track
 Medical Gloves w/Disposable System
 First Aid Kit - 24 Unit
 Vent Fan Cover- For Header Comp.
 Gel Hand Sanitizer
 Ritter 281 Blood Draw Chair
 Vent Fan Header Compartment
 Girard 9' Power Awning with LED Lights
 Sewer Hose Carrier 26"
 (2) Coat Hook
 Accucold Medical Grade Refrigerator 5.5 cu ft
 Eye Wash Station
 Sewer Hose
 Ritter 204 Exam Table
 5 Lb. Extinguisher 3A 40 BC
 Triangle Reflectors
 Door Stopper-Dome
 (2) Cab Privacy Curtain 47X64

Climate Control

(2) (2) Roof Vent - Fantastic 4000 Series 14"
 Roof A/C 15,000 BTU with Thermostat

Doors/Windows/Mirrors

Entrance Door, Electric - Built In Cab, 29"
 Interior Door Switch (For Front Passenger Entrance Door)
 Kubota Key Switch - Exterior

Electrical

Pull 110v 12 Ga. SL Cable, Coiled Up to Front Bulkhead Area
 110V Electrical
 (2) Interior Switch for Dome Lights
 (5) 110v Outlet with Faceplate - 110v Duplex Outlet
 Replace Standard Dome Lights with 4" x 11" LED Lights
 Additional 4" x 11" LED Light
 Full Battery Disconnect Switch (Mounted in Drivers Stepwell)
 Terra Transit Pullout Battery Tray
 RVS Backup Camera - 7" Mirror Monitor
 (2) 12v Wire Circuit
 110V Transfer Switch
 25' 50 Amp Shore Power Cord w/ Inlet plug wired to transfer switch
 (2) Pull 110v 14/2 Ga. SL Wire Lead
 QG7000 Generator

90A All-in-one 240V 18 pos Converter w/ Resettable Breakers
 Wire One 110v Outlet To Be Hot At All Times
 110v Exterior GFI Outlet
 Thor TH002 MFG Inverter Switch
 2000w Inverter Located In the B-Pillar

Exam Specific Electrical

Inlet on Side of Vehicle for Plug In
 110v Package Includes 5 Outlets - 10 Plugs
 Cummins Onan 7.0 Generator GL7000 w/Remote Starter Switch
 Breaker Box, Breakers and Transfer Switch
 50 Amp Shore Power with Cord, 28' Length

Exterior

Generator Prep Kit
 Generator Endosure Kit
 Running Board - Wide Diamond Plate (Driver's Side)
 All Storage Areas Locked and Keyed the Same

Front Exam Room

Small Lab Area w/Medical Grade Refrig Under Counter Top & Custom Laminated Upper Locking Cabinets
 Custom Laminate Cabinet Locking Drawers
 LED Lighting Under Upper Cabinets
 Custom Laminate Locking Cabinets

Interior

Restroom Kit-Locking Door, Mirror, Sink, Toilet, Gray Tank, Fresh Water
 Stanchion Pole w/Assist R.H. Entry
 Flip Seat - Featherweight, Single Mid-Back 17" w/ Lap Belts
 Yellow Step Treads
 Altro Faux Wood Flooring Upgrade (Iron Bamboo)
 Exterior Skirt Storage (36" w x 16" h x 21" d)
 Storage Compartment - Over Driver
 Smooth White Interior Walls - Gray Vinyl Corner Boards Shipped Loose
 Additional Steel Strapping/Backer in Sidewall, Curbside for Cabinets
 Restroom Kit-Locking Door, Mirror, Sink, Toilet, Gray Tank, Fresh Water
 Additional Steel Backer - Behind Driver Seat
 White Fiberglass Wall with Door

Paratransit Equipment

Wheelchair Lift Belt
 Braun NCL1000LB3454 1000# Lift
 Double W/C Lift Door - Deluxe

Rear Exam Room

Custom Laminate Locking Cabinets
 Custom Laminate Locking Cabinet Drawers
 LED Lighting Under Upper Cabinets

Safety

LED Brake Light - Center High Mount
 Back Up Alarm
 Locking Fuel Door - Deluxe

Terms: Payment Before Delivery 50% Deposit Required
 Quote Valid For: 30 Days
 Delivery: Subject to Prior Sale

Terms and conditions of sale are expressly incorporated herein as stated on TESCO Specialty Vehicles's website at tescosv.com/terms/.

Sales Rep.

Purchaser

Fed Tax ID #

Date

Unit Price	\$249,900.00
Mobility Rebate	(\$1,000.00)
Discount	(\$10,000.00)
Delivery	None

Unit Total \$238,900.00

Ext. Total	\$238,900.00
Trade-in(s)	None
Net Total	\$238,900.00

4/12/2024

Ben Connors p 419-720-7433
 bconnors@tescobus.com f 419.836.8460

Alachua County Fire Rescue

15040 NW US HWY 441
 Alachua FL 32615

David Lykens
 407-257-9575
 dlykens@alachuacounty.us

5434 Navarre Ave www.tescosv.com
 P.O. Box 167230 855.376.9797
 Oregon OH 43616

Trades

Floorplan

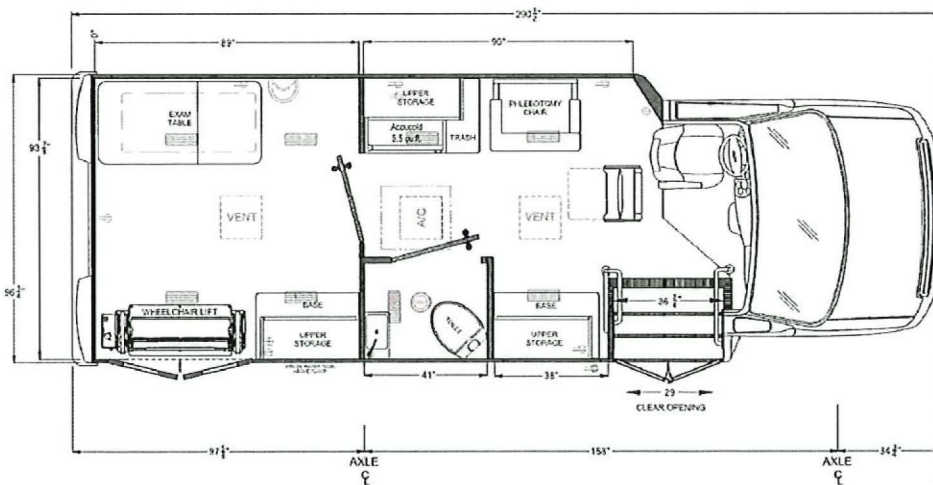

CUSTOMER APPROVAL PROJ. NAME VISIT DATE		TESCO SPECIALTY VEHICLES 3840 N. W. 10th Ave Ft. Lauderdale, FL 33304 954.776.8737	# BUILD HISTORY REV. DESCRIPTION 1 PRELIMINARY LAYOUT	ENGINEER DATE A. PUGH 7/26/2023	TERRA TRANSIT - ADA 25 FORD E450
SALES DRAWING 5.0		TERRA TRANSIT 25 FORD E450 PART NO. 27211023 1310443 CWS 040210403 TOLERANCE 4 X 1/2 8			

4/12/2024

Ben Connors p 419-720-7433
 bconnors@tescobus.com f 419.836.8460

5434 Navarre Ave www.tescosv.com
 P.O. Box 167230 855.376.9797
 Oregon OH 43616

Alachua County Fire Rescue

15040 NW US HWY 441
 Alachua FL 32615

David Lykens
 407-257-9575
 dlykens@alachuacounty.us

Additional Suggested Options

Spot Graphics	\$5,000.00
Welch/Allyn Diagnostic Board	\$2,900.00
Graphics Full Wrap	\$10,000.00
Delivery - \$2.15 Per Mile	\$2,104.00

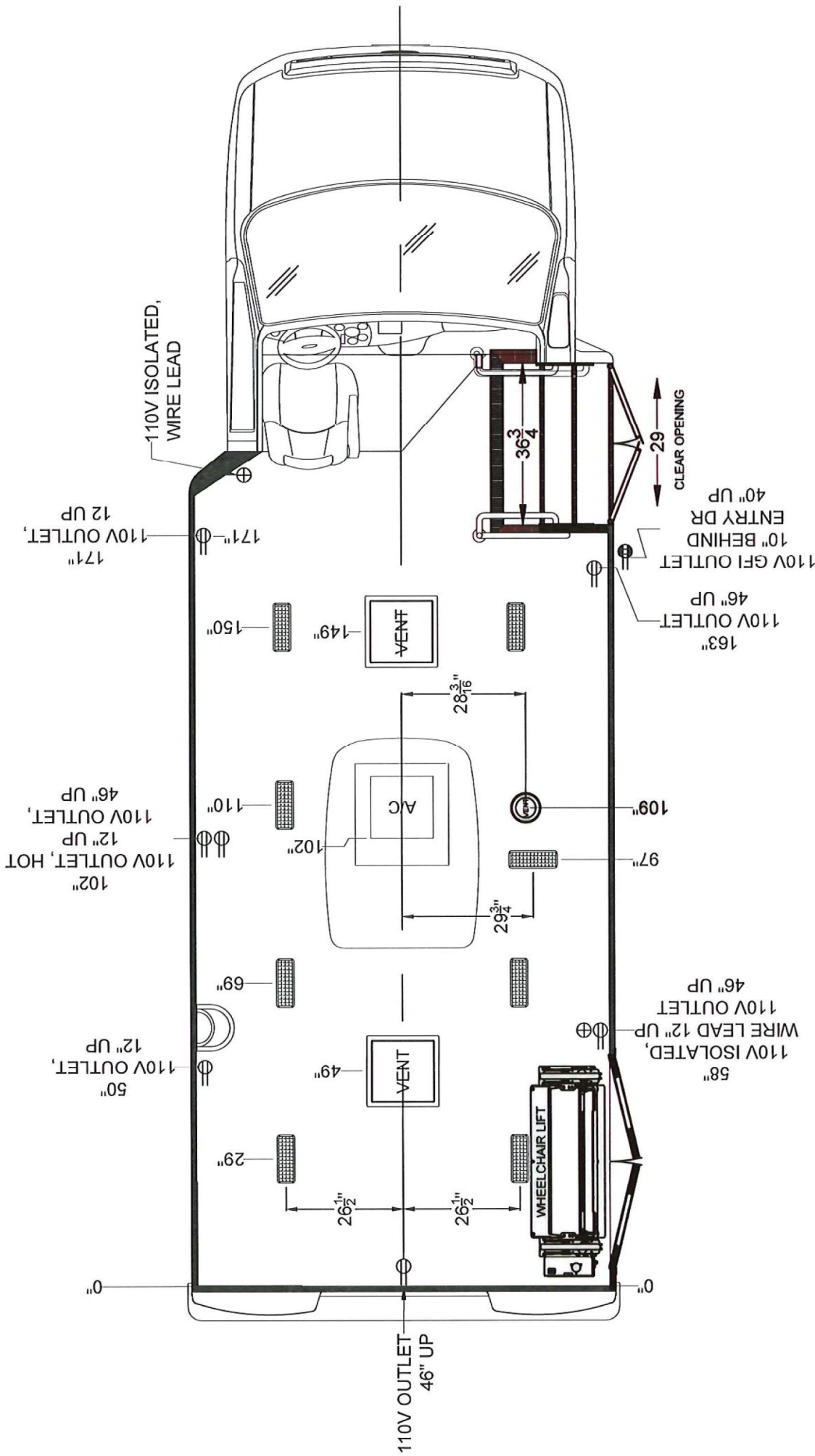

CONTACT TURTLE TOP AT 800-269-2105 FOR AVAILABILITY OF THIS FLOOR LAYOUT IF DRAWING DATE HAS EXCEEDED 90 DAYS.

DATE: 8/9/2022

FILE NAME: TERRA TRANSIT-MD_ADA_190 FL

- NOTES
- = 4 x 11" LED LIGHT
 - = 110V GFI DUPLEX OUTLET
 - = 110V DUPLEX OUTLET
 - = WIRE LEAD

3 STEP ENTRY
TERRA TRANSIT
 2 STEP ENTRY
 W/ WHEEL WELLS

THIS DRAWING AND THE INFORMATION CONTAINED THEREON ARE THE EXCLUSIVE PROPERTY OF TURTLE TOP AND SHALL NOT BE COPIED OR REPRODUCED IN ANY MANNER WITHOUT OUR WRITTEN CONSENT.

DRAFTSMAN NOTES:
 * NON-STANDARD FLOOR LENGTH
 REV B-ENTRY DOOR CHANGE TO SEDAN DR/SLS-12.6.22
 REV C- REVERT TP BI-FOLD ENTRY DOOR/SLS-1.26.23

ELECTRICAL OUTLET & LIGHTING LOCATIONS

TURTLE TOP
 "To furnish the customer the best mid-sized bus in the industry in both quality of material and workmanship."

CHASSIS MAKE: FORD E-450
 CHASSIS MODEL: 141 FORD L1
 CHASSIS FUEL TYPE: 7.3L GAS
 FLOOR LENGTH: 190"
 OVER ALL LENGTH: 24' 2"
 ORDER NUMBER:
 DRAWING NUMBER:

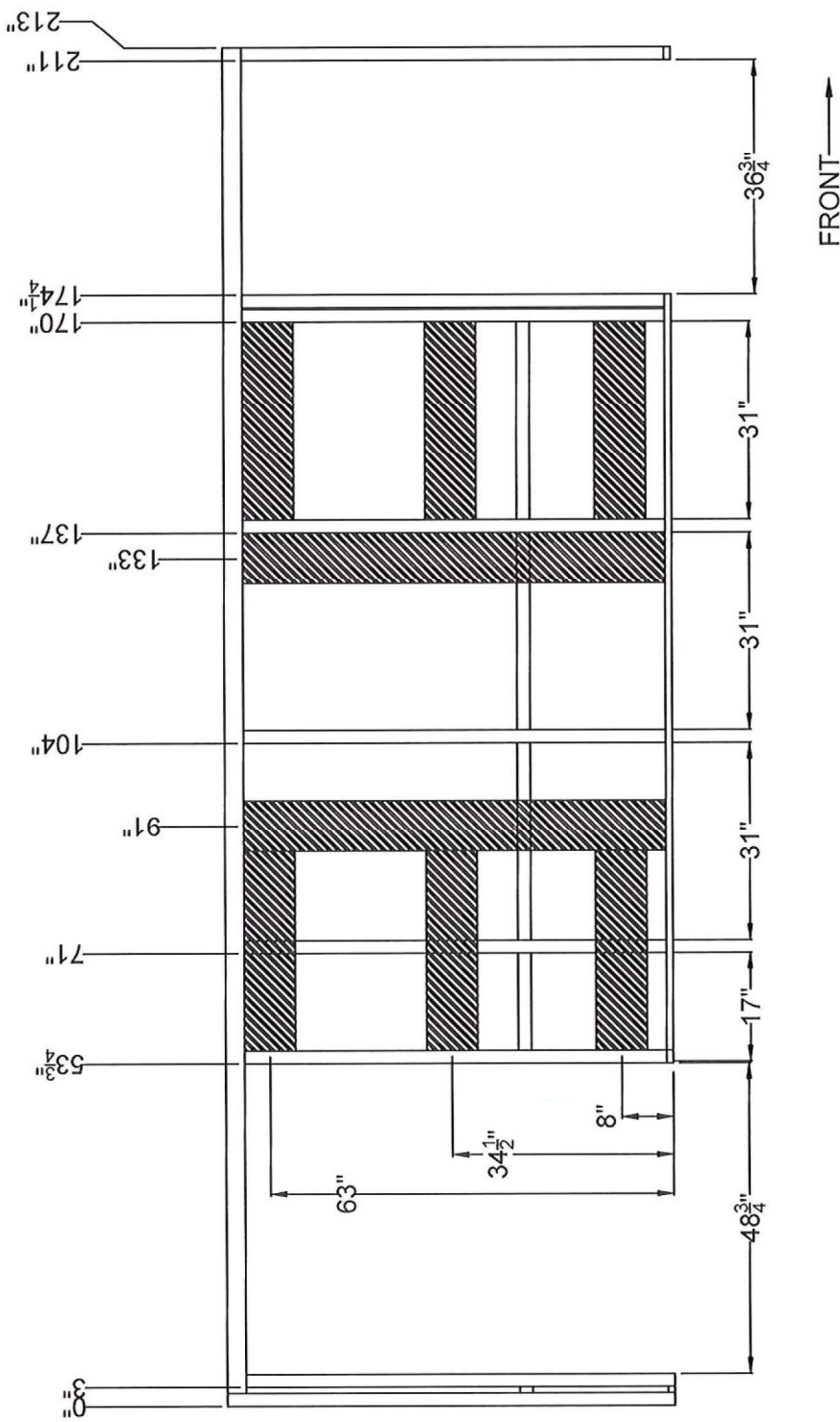

CONTACT TURTLE TOP AT 800-268-2105 FOR AVAILABILITY OF THIS FLOOR LAYOUT IF DRAWING DATE HAS EXCEEDED 90 DAYS. DATE: 8/9/2022



FILE NAME: TERRA TRANSIT-MID_ADA_190 FL

3 STEP ENTRY 2 STEP ENTRY
TERRA TRANSIT W/ WHEEL WELLS
 DRAFTSMAN NOTES:
 * NON-STANDARD FLOOR LENGTH
 OVER ALL LENGTH: 24' 2" FLOOR LENGTH: 190"

NOTES

= 14 GA STEEL BACKER INTERIOR
 SEE ADDITIONAL PRINT FOR
 EXTERIOR BACKER
 CURB SIDE WALL FRAME
 & STEEL BACKER INTERIOR

THIS DRAWING AND THE INFORMATION CONTAINED THEREON ARE THE EXCLUSIVE PROPERTY OF TURTLE TOP AND SHALL NOT BE COPIED OR REPRODUCED IN ANY MANNER WITHOUT OUR WRITTEN CONSENT.
 DRAFTSMAN: REBORN SCALE: 1:1 DIMENSIONING TO IFRANCE = +/- .3"

ORDER NUMBER: ORDER CHASSIS NAME: FORD E-450
 DRAWING NUMBER: E07724 E07727 CHASSIS FUEL TYPE: 7 21 CAC CHASSIS GVWR: 14 000 lbs



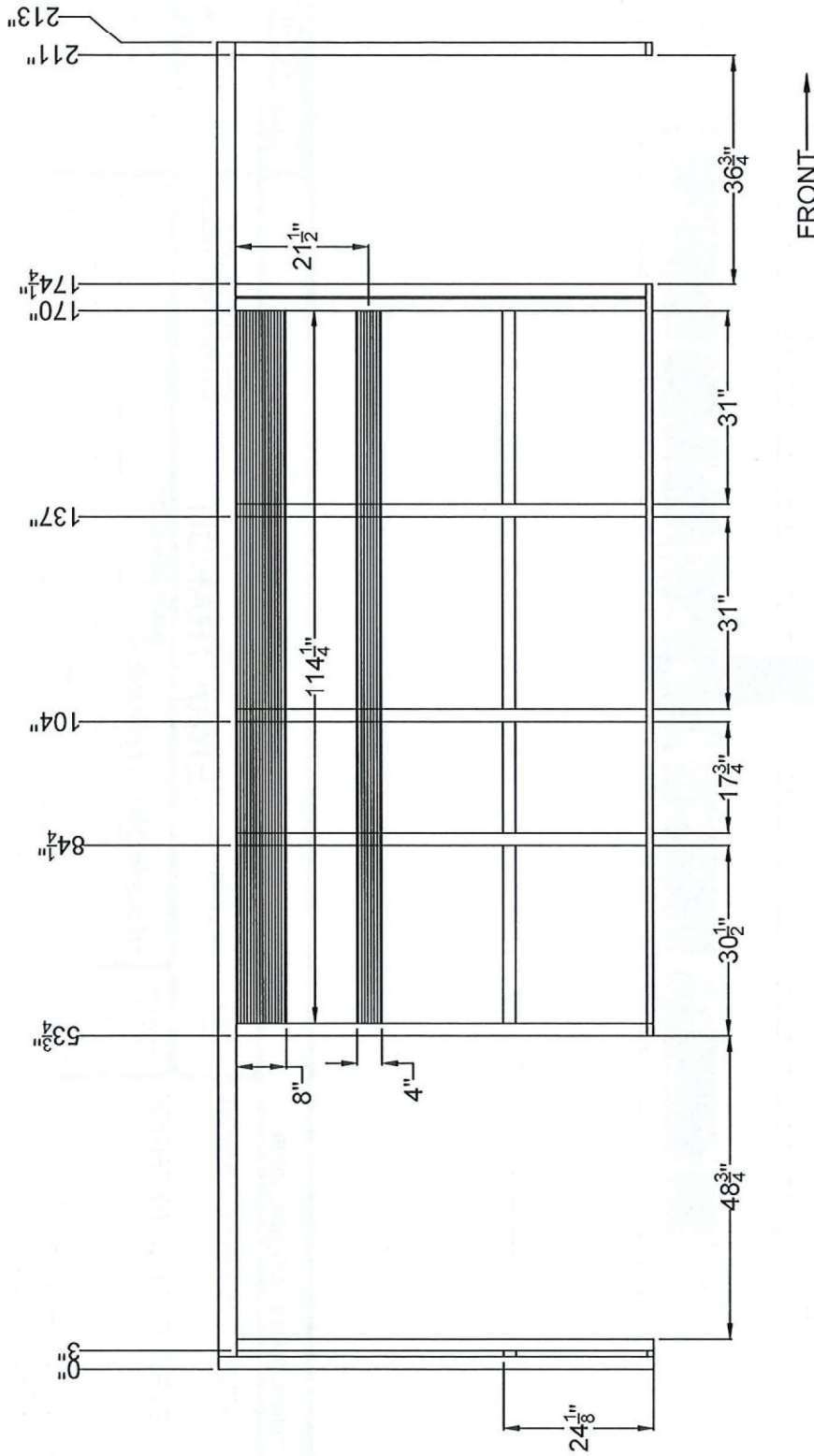

CONTACT TURTLE TOP AT 800-269-2105 FOR AVAILABILITY OF THIS FLOOR LAYOUT IF DRAWING DATE HAS EXCEEDED 90 DAYS. DATE: 8/9/2022



FILE NAME: TERRA TRANSIT-MD_ADA_190 FL

3 STEP ENTRY
 2 STEP ENTRY
 W/WHEEL WELLS

TERRA TRANSIT

DRAFTSMAN NOTES:

- * NON-STANDARD FLOOR LENGTH

THIS DRAWING AND THE INFORMATION CONTAINED THEREON ARE THE EXCLUSIVE PROPERTY OF TURTLE TOP AND SHALL NOT BE COPIED OR DUPLICATED IN ANY MANNER WITHOUT OUR WRITTEN CONSENT.

TURTLE TOP BODY MODEL: **TERRA TRANSIT**
 CHASSIS MAKE: **FORD E-450**
 CHASSIS FUEL TYPE: **7 91 GAS**
 OVER ALL LENGTH: **24' 2"**
 DIMENSIONING TO IFRANCE = +/- .3" FLOOR LENGTH: **190"**

NOTES
 = 14 GA STEEL BACKER EXTERIOR
 SEE ADDITIONAL PRINT FOR
 INTERIOR BACKER
 CURB SIDE WALL FRAME
 & STEEL BACKER EXTERIOR



ORDER NUMBER: **ORDER**

DRAWING NUMBER: **EN0724 EN0727**

CHASSIS OWNER: **14 ENO, Inc**

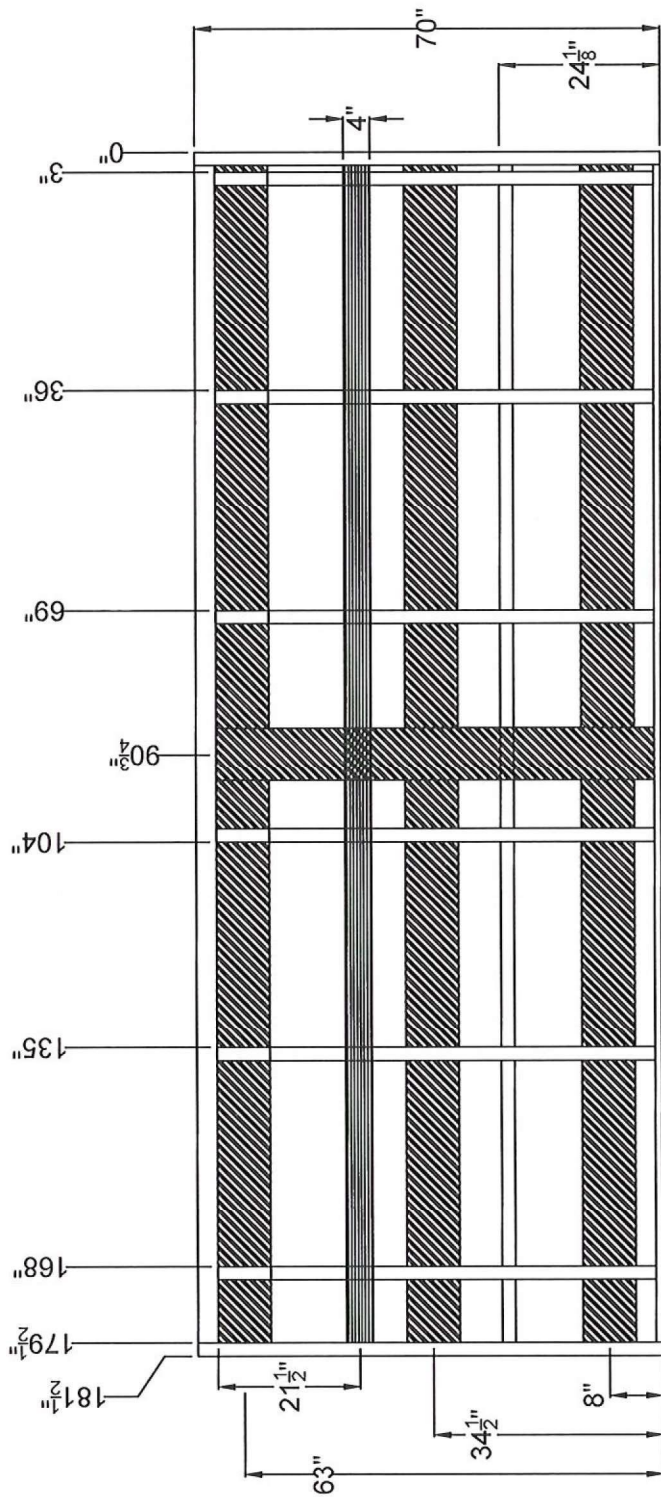

FRONT

CONTACT TURTLE TOP AT 800-268-2105 FOR AVAILABILITY OF THIS FLOOR LAYOUT IF DRAWING DATE HAS EXCEEDED 90 DAYS. DATE: 8/9/2022



TURTLE TOP
 "To furnish the customer the best mid-sized bus in the industry in both quality of material and workmanship."

FILE NAME: **TERRA TRANSIT-MID_ADA_190 FL**

NOTES

-  = 14 GA STEEL BACKER INTERIOR
-  = 14 GA STEEL BACKER EXTERIOR

ROAD SIDE WALL FRAME & STEEL BACKER

3 STEP ENTRY 2 STEP ENTRY

W/WHEEL WELLS

TERRA TRANSIT

DRAFTSMAN NOTES:

- * NON-STANDARD FLOOR LENGTH

"THIS DRAWING AND THE INFORMATION CONTAINED THEREON ARE THE EXCLUSIVE PROPERTY OF TURTLE TOP AND SHALL NOT BE COPIED OR REPRODUCED IN ANY MANNER WITHOUT OUR WRITTEN CONSENT."

DRAFTSMAN: REBSON: SCS SCALE: N/A DIMENSIONING TO: FRAMCF = +/- .3"

TURTLE TOP BODY MODEL: **TERRA TRANSIT**

OVER ALL LENGTH: **24' 2"** FLOOR LENGTH: **190"**

CHASSIS MAKE: **FORD E-450** CHASSIS FUEL TYPE: **7 21 GAS**

CHASSIS GVWR: **14,400 lbs**

ORDER NUMBER: **ORDER** DRAWING NUMBER: **EN0724 EN0737**

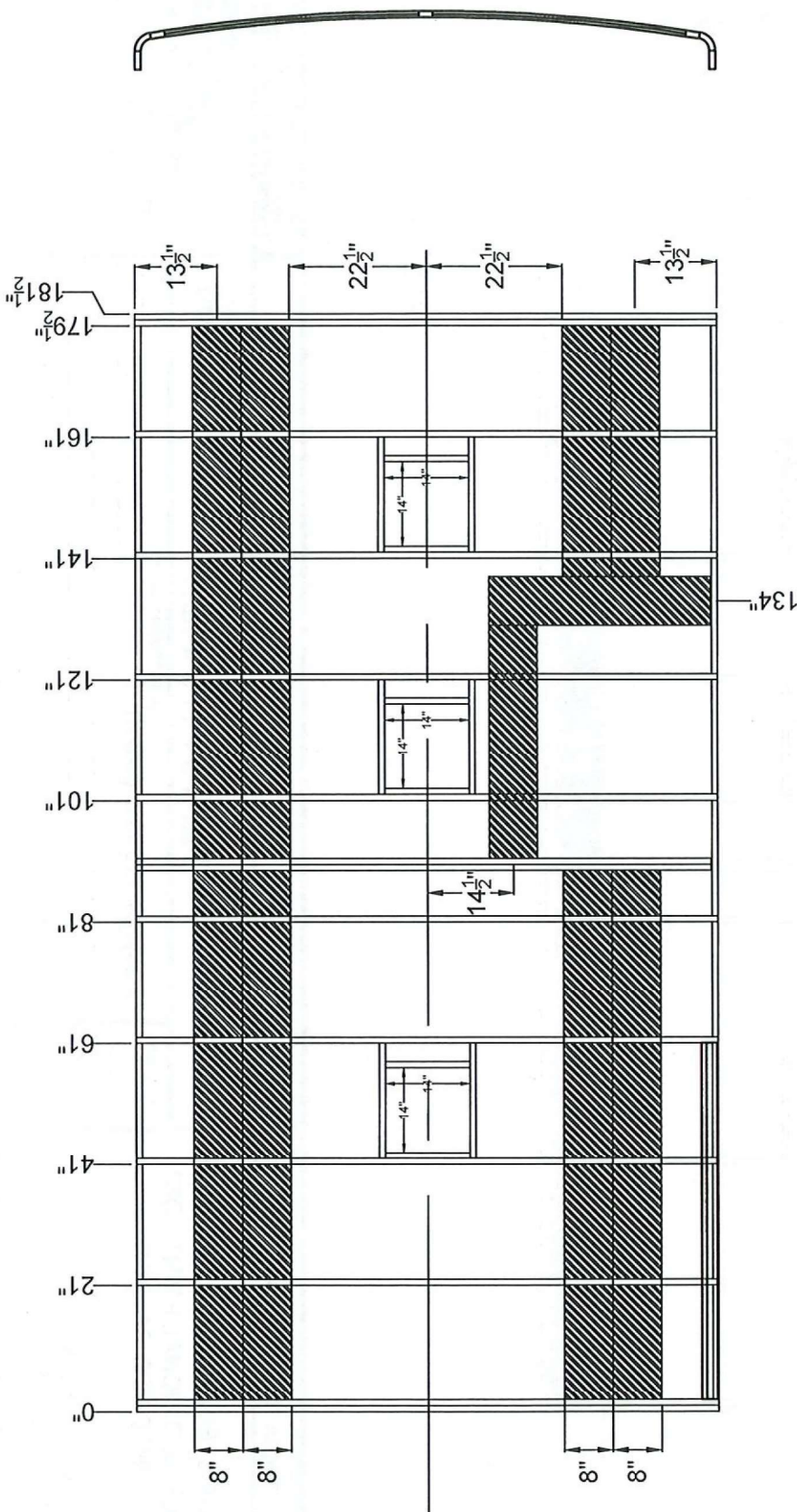

CONTACT TURTLE TOP AT 800-268-2105 FOR AVAILABILITY OF THIS FLOOR LAYOUT IF DRAWING DATE HAS EXCEEDED 90 DAYS.

DATE: 8/6/2022

TURTLE TOP
"To furnish the customer the best mid-sized bus in the industry in both quality of material and workmanship."

ORDER NUMBER: **ORDER**
 DRAWING NUMBER: **ENC724 ENC727**

CHASSIS MAKE: **FORD E-450**
 CHASSIS FUEL TYPE: **7.3I GAS**
 CHASSIS GVWR: **14,450 lbs**

OVER ALL LENGTH: **24' 2"**
 FLOOR LENGTH: **190"**
 DIMENSIONING TO FRONCF = +/- 3"

TURTLE TOP BODY MODEL: **TERRA TRANSIT**
 SCALE: **1:1**

THIS DRAWING AND THE INFORMATION CONTAINED THEREON ARE THE EXCLUSIVE PROPERTY OF TURTLE TOP AND SHALL NOT BE COPIED OR DUPLICATED IN ANY MANNER WITHOUT OUR WRITTEN CONSENT.

DRAFTSMAN: **CS** REVISIONS: **U**

3 STEP ENTRY **TERRA TRANSIT** 2 STEP ENTRY
 W WHEEL WELLS

DRAFTSMAN NOTES:
 * NON-STANDARD FLOOR LENGTH

NOTES
 = 14 GA STEEL BACKER INTERIOR
 SEE ADDITIONAL PRINT FOR
 EXTERIOR BACKER
 ROOF STRUCTURE &
 INTERIOR BACKER

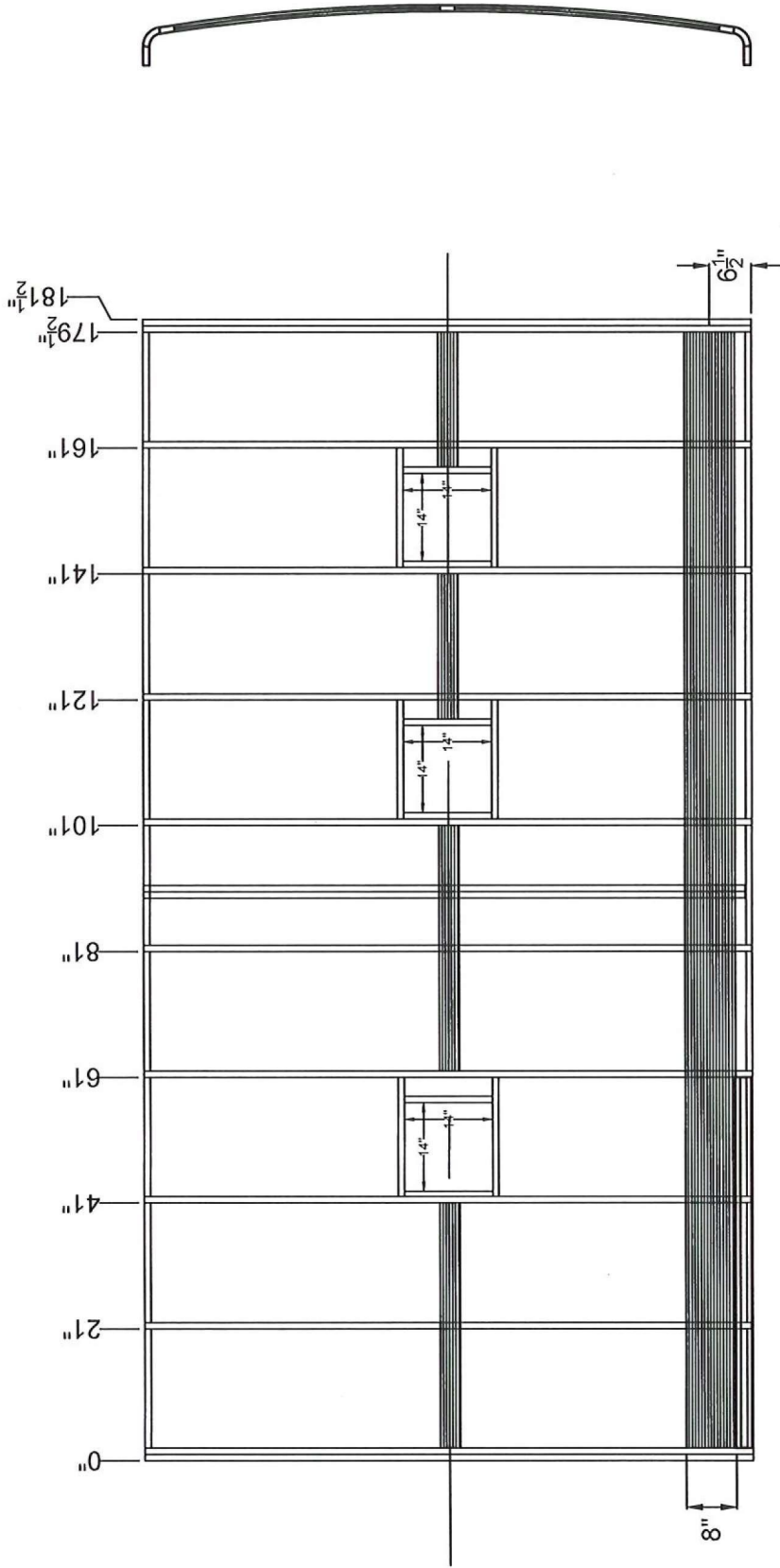

FRONT →

CONTACT TURTLE TOP AT 800-985-2105 FOR AVAILABILITY OF THIS FLOOR LAYOUT IF DRAWING DATE HAS EXCEEDED 90 DAYS. DATE: 8/9/2022

TURTLE TOP
"To furnish the customer the best mid-sized bus in the industry in both quality of material and workmanship."

FILE NAME: TERRA TRANSIT-MID_ADA_190 FL

3 STEP ENTRY 2 STEP ENTRY

W/ WHEEL WELLS

TERRA TRANSIT

DRAFTSMAN NOTES:
 * NON-STANDARD FLOOR LENGTH

OVER ALL LENGTH: 24' 2" FLOOR LENGTH: 190"

TURTLE TOP BODY MODEL: TERRA TRANSIT CHASSIS MAKE: FORD E-450

SCALE: N.A.S. DIMENSIONING TO IFRANCE = +/- .3" CHASSIS FUEL TYPE: 7.3I CASC CHASSIS GVWR: 14,500 lbs

ORDER NUMBER: ORDER DRAWING NUMBER: E07724 E07727

NOTES

- █ = 14 GA STEEL BACKER EXTERIOR
- *SEE ADDITIONAL PRINT FOR* INTERIOR BACKER
- ROOF STRUCTURE & EXTERIOR STEEL BACKER

STEEL INTERIOR WALL

ALUM LAV WALLS

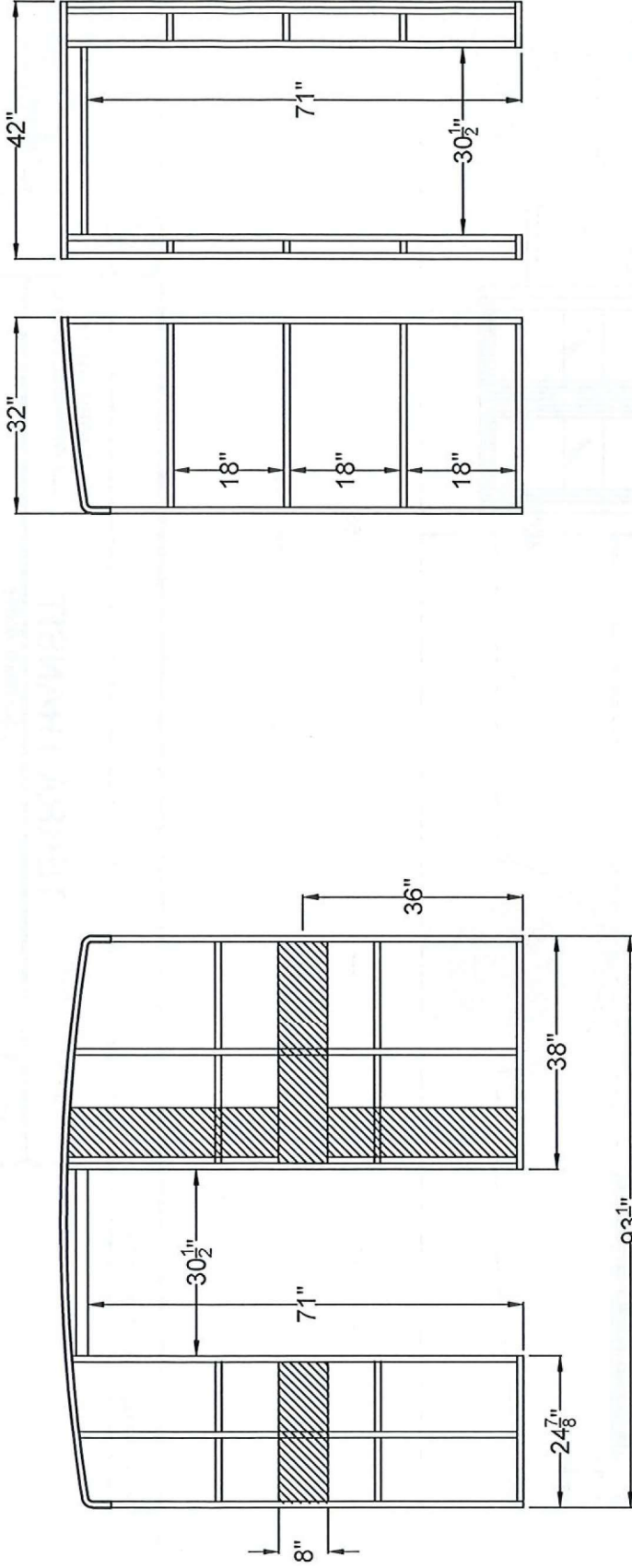

NOTES
 FILE NAME: TERRA TRANSIT-MD_ADA_190 FL

= 14 GA STEEL BACKER
 BOTH SIDES OF WALL

3 STEP ENTRY
TERRA TRANSIT
 *NON-STANDARD FLOOR LENGTH

2 STEP ENTRY
 W/ WHEEL WELLS

THIS DRAWING AND THE INFORMATION CONTAINED THEREON ARE THE EXCLUSIVE PROPERTY OF TURTLE TOP AND SHALL NOT BE COPIED OR Duplicated IN ANY MANNER WITHOUT OUR WRITTEN CONSENT.
 DRAFTSMAN: CTS
 REVISION: R

DRAFTSMAN NOTES:
 OVER ALL LENGTH: 24' 2"
 FLOOR LENGTH: 190"
 DIMENSIONING TOI FRANCH = +/- .3"
 TURTLE TOP BODY MODEL: TERRA TRANSIT
 SCALE: 1/8" = 1'-0"
 CHASSIS MAKE: FORD E-450
 CHASSIS FUEL TYPE: 7.91 GAS
 CHASSIS GVWR: 14,500 LB

INTERIOR WALL FRAMES



CONTACT TURTLE TOP AT 800-268-2105 FOR AVAILABILITY OF THIS FLOOR LAYOUT IF DRAWING DATE HAS EXCEEDED 90 DAYS.
 DATE: 8/9/2022



ORDER NUMBER: ORDER
 DRAWING NUMBER: E00794 E00797

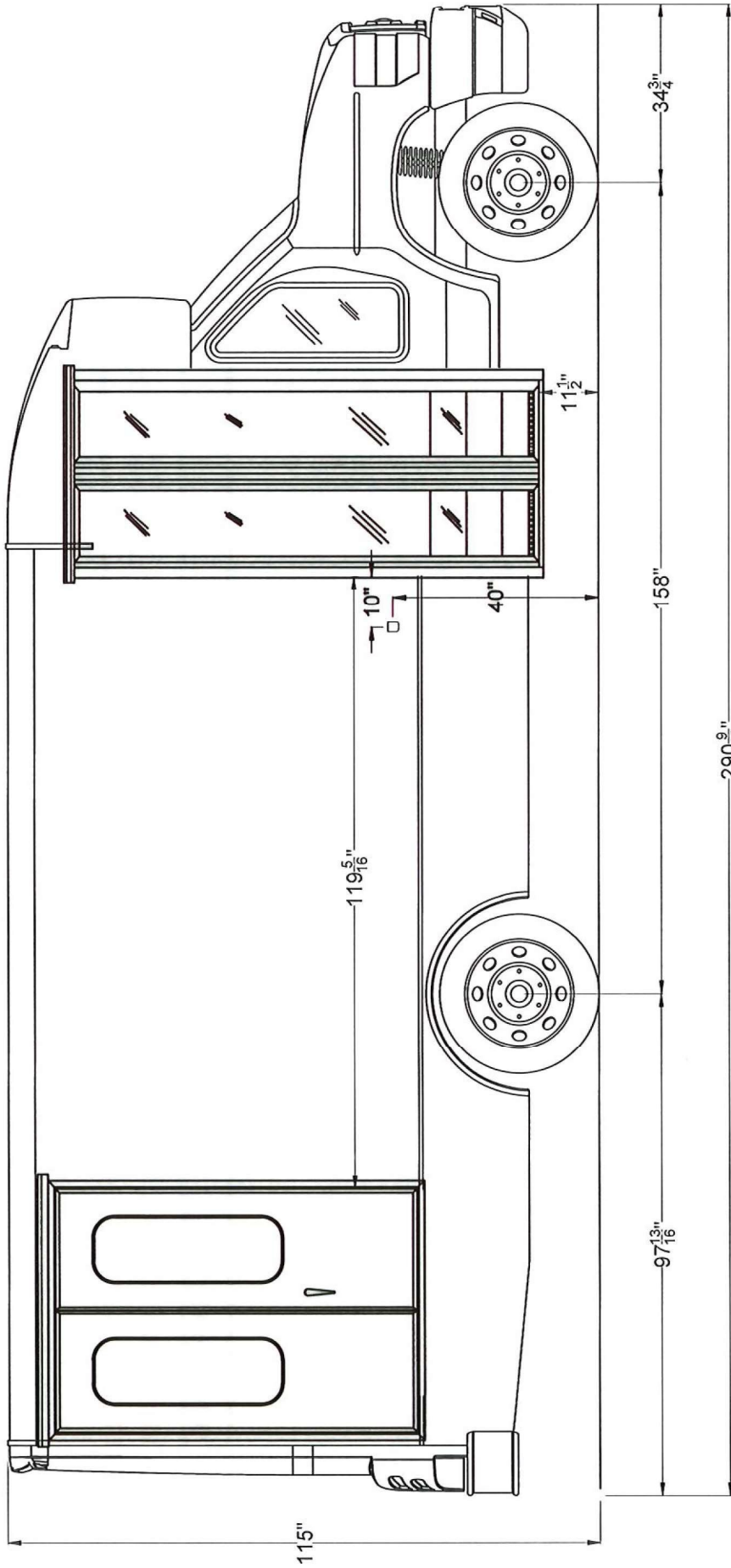

CONTACT TURTLE TOP AT 800-289-2105 FOR AVAILABILITY OF THIS FLOOR LAYOUT IF DRAWING DATE HAS EXCEEDED 90 DAYS. DATE: 8/9/2022



TURTLE TOP
 "To furnish the customer the best mid-sized bus in the industry in both quality of material and workmanship."

FILE NAME: **TERRA TRANSIT-MD_ADA_190 FL**

3 STEP ENTRY 2 STEP ENTRY
TERRA TRANSIT W/ WHEEL WELLS

DRAFTSMAN NOTES:

- * NON-STANDARD FLOOR LENGTH
- REV B-ENTRY DOOR CHANGE TO SEDAN DR/SLS-12.6.22
- REV C- REVERT TP BI-FOLD ENTRY DOOR/SLS-1.26.23

OVER ALL LENGTH: **24' 2"** FLOOR LENGTH: **190"**
 DIMENSIONING TO IFRANCE = +/- .3"

CHASSIS MAKE: **FORD E-450**
 CHASSIS FUEL TYPE: **7.3L GAS**
 CHASSIS GVWR: **14,400 lbs**

ORDER NUMBER: **ORDER**
 DRAWING NUMBER: **E00734 E00737**

THIS DRAWING AND THE INFORMATION CONTAINED THEREON ARE THE EXCLUSIVE PROPERTY OF TURTLE TOP AND SHALL NOT BE REPRODUCED IN ANY MANNER WITHOUT OUR WRITTEN CONSENT.

DRAFTSMAN: **CS** REVISION: **0** SCALE: **N.A.S.**

TURTLE TOP BODY MODEL: **TERRA TRANSIT**



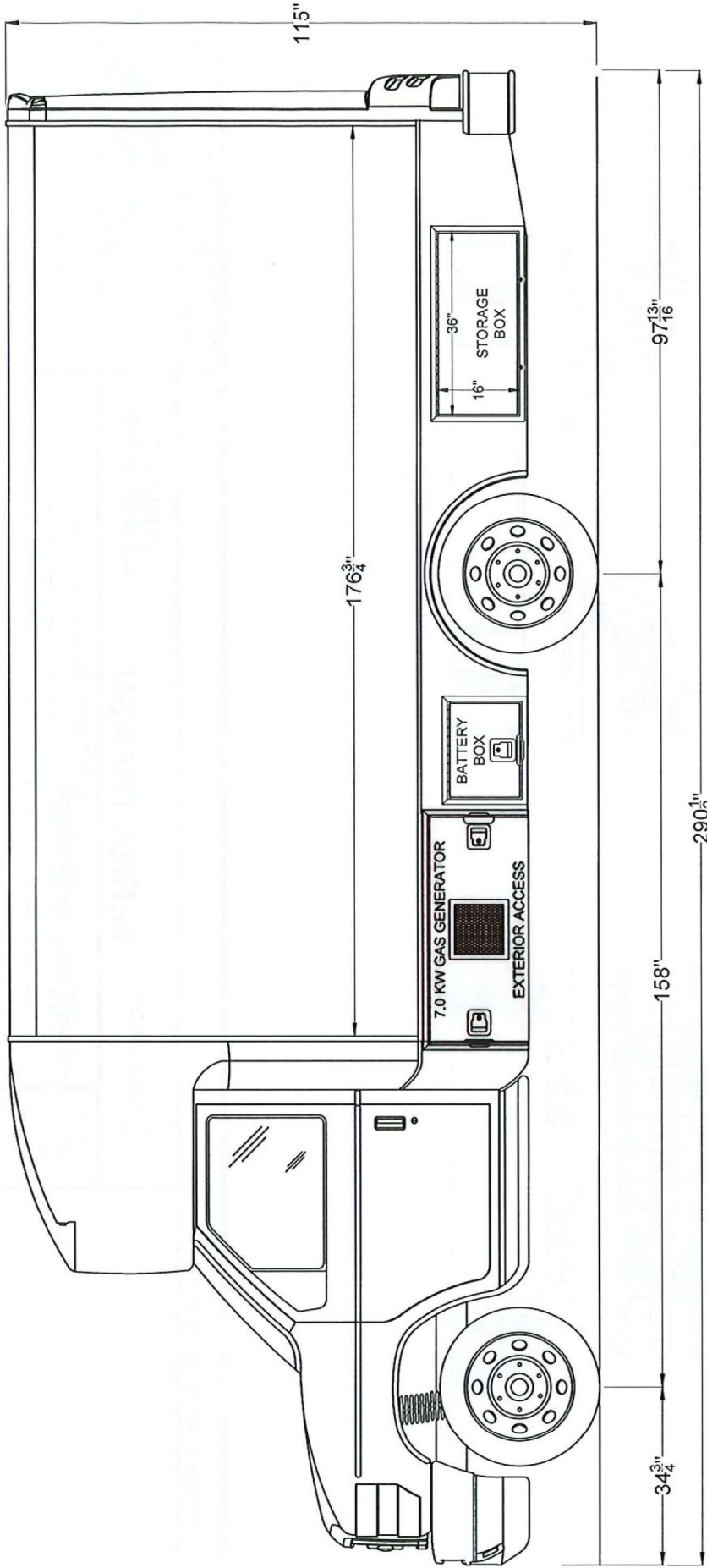

CONTACT TURTLE TOP AT 800-268-2105 FOR AVAILABILITY OF THIS FLOOR LAYOUT IF DRAWING DATE HAS EXCEEDED 90 DAYS.

DATE: 8/19/2022

FILE NAME: TERRA TRANSIT-MD_ADA_190 FL

NOTES

3 STEP ENTRY

2 STEP ENTRY

W WHEEL WELLS

TERRA TRANSIT

* NON-STANDARD FLOOR LENGTH

DRAFTSMAN NOTES:

THIS DRAWING AND THE INFORMATION CONTAINED THEREON ARE THE EXCLUSIVE PROPERTY OF TURTLE TOP AND SHALL NOT BE COPIED OR REPRODUCED IN ANY MANNER WITHOUT OUR WRITTEN CONSENT.

DRAWING NUMBER: 190
 REVISION: 1
 SCALE: N/A
 DIMENSIONING TO: FRONTS = +/- .3"

OVER ALL LENGTH: 24' 2"

FLOOR LENGTH: 190"

TURTLE TOP BODY MODEL: TERRA TRANSIT

CHASSIS MAKE: FORD E-450

CHASSIS FUEL TYPE: 7.3I GAS

CHASSIS GVWR: 14,100 lbs

TURTLE TOP

"To furnish the customer the best mid-sized bus in the industry in both quality of material and workmanship."

ORDER NUMBER: ORDER
 DRAWING NUMBER: E07724 E07727

MVP verified member

1st Quality FIRST

clearnet

QVM

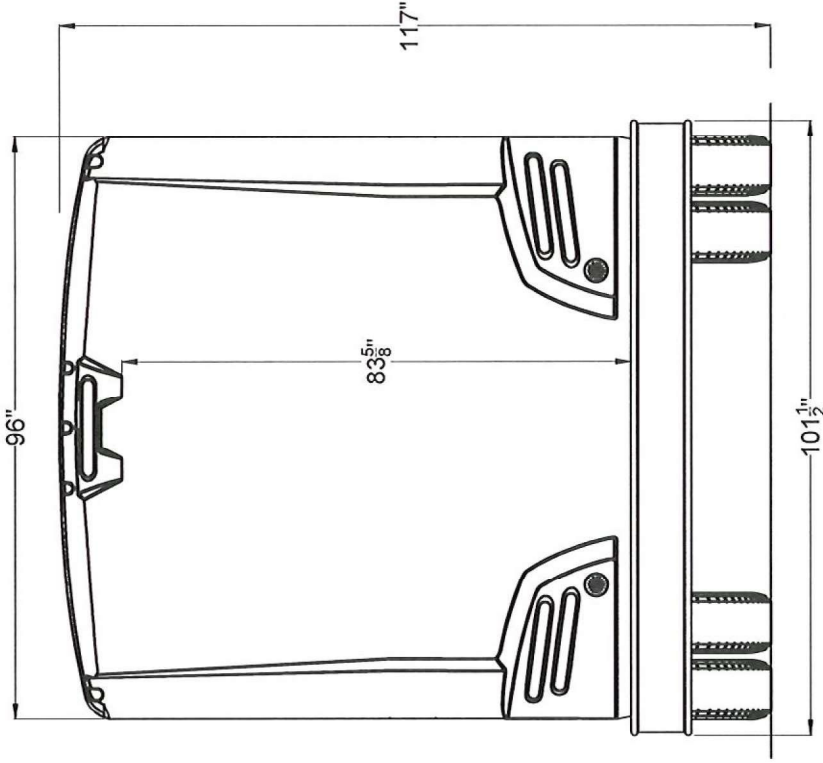
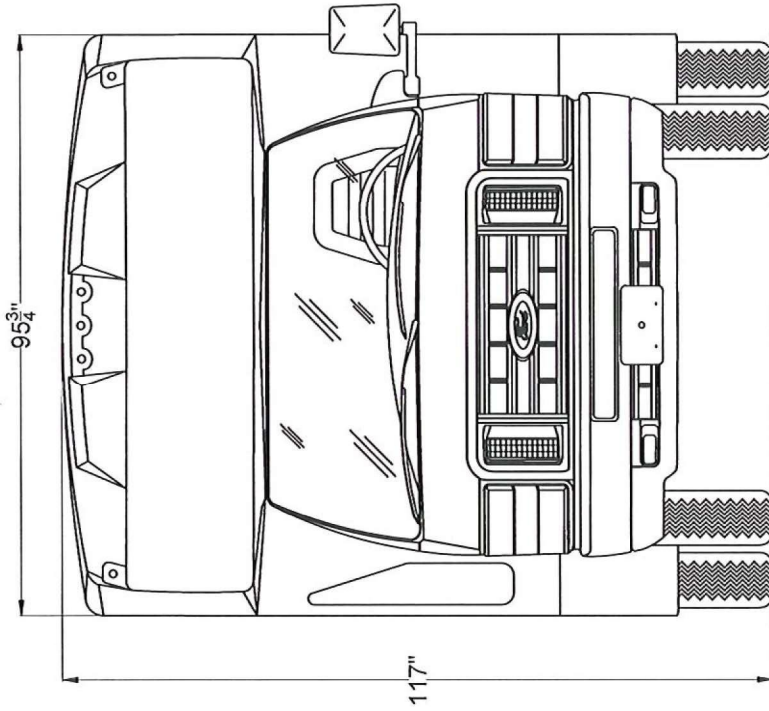

CONTACT TURTLE TOP AT 800-289-2105 FOR AVAILABILITY OF THIS FLOOR LAYOUT IF DRAWING DATE HAS EXCEEDED 90 DAYS.

DATE: 8/9/2022

FILE NAME: TERRA TRANSIT-MD_ADA_190 FL

NOTES

3 STEP ENTRY 2 STEP ENTRY

TERRA TRANSIT W/ WHEEL WELLS

DRAFTSMAN NOTES:

- * NON-STANDARD FLOOR LENGTH

OVER ALL LENGTH: 24' 2"

FLOOR LENGTH: 190"

TURTLE TOP BODY MODEL: TERRA TRANSIT

CHASSIS MAKE: FORD E-450

CHASSIS FUEL TYPE: 7.3L GAS

CHASSIS GVWR: 14,400 lbs.



TURTLE TOP

"To furnish the customer the best mid-sized bus in the industry in both quality of material and workmanship."

ORDER NUMBER: ORDER

DRAWING NUMBER: E00794 E00797

THIS DRAWING AND THE INFORMATION CONTAINED THEREON ARE THE EXCLUSIVE PROPERTY OF TURTLE TOP AND SHALL NOT BE COPIED OR DUPLICATED IN ANY MANNER WITHOUT OUR WRITTEN CONSENT.

DRAFTSMAN: REVISION: SCALE: DIMENSIONING TO: FRAMING = +/- .3"

