

HON

2020 LIST PRICER



FURNITURE

EFFECTIVE JANUARY, 2020
Supersedes HON List Pricer
Dated June 2019

LIST PRICER

Effective Date: January 2020

- All illustrations and specifications in this publication are based on the latest product information available at the time of print. For the most recent version, please go to <https://www.hon.com/pricer>.
- Software support packages furnished to the customer, either by The HON Company or by another source, which support the sale of HON products are superseded by printed price lists.
- All dimensions shown in this publication are nominal.
- Pricing is subject to change without notice.
- All orders are subject to prices in effect at the time of order.
- Ordering information appears at the beginning of a section complete with examples on how to specify. These specifying information pages are referenced at the bottom center of product pages.
- HON Full Lifetime Warranty applies unless otherwise noted.
- HON nationwide customer service:
Phone: (800) 833-3964

HON LIST PRICER

Table of Contents

INTRODUCTION

Table of Contents.....	1-4
Additions.....	5
Discontinuations.....	6
HON Full Lifetime Warranty Information.....	8
HON Limited 5-Year Warranty Information.....	9
Ordering Information.....	10
Integrated Design Solutions.....	11
Tailored Solutions Ordering Information.....	12
Customer's Own Material Ordering Information.....	13-14
Partnership Textile Information.....	15
Paint Program.....	16
Environmental Statement.....	17
Important Information.....	18
Legend.....	19
Fabric Patterns & Codes.....	20
Lead Times.....	21
Fabric Patterns & Codes.....	22-24
Panel Fabric Patterns & Codes.....	25-26

DESKS

Features Offered on HON Laminate Caseloads.....	27
Concinnity™	28
Concinnity™ Ordering Information	29
Concinnity™ Ordering Specification/Model Logic	30-31
Concinnity™ Laminate Design/Materials Information	32-33
Concinnity™ Laminate Ordering/Specification Information	34-35
Concinnity™ Cord Management.....	36-37
Concinnity™ Typicals.....	38-42
Concinnity™ Desks.....	43-45
Concinnity™ Peninsulas.....	46-47
Concinnity™ Corner Unit.....	48
Concinnity™ Credenzas.....	49
Concinnity™ Low Credenzas.....	50
Concinnity™ Returns.....	51
Concinnity™ Bridges.....	52
Concinnity™ Stack-on Storage Applications	53-54
Concinnity™ Stack-on Storage.....	55-59
Concinnity™ Wall Mount Storage Applications	60-61
Concinnity™ Wall Mount Storage.....	62-65
Concinnity™ Bookcase Hutches.....	66-67
Concinnity™ Reception Stations.....	68-70
Concinnity™ Mobile Pedestals.....	71
Concinnity™ Lateral Files.....	72
Concinnity™ Storage Cabinets.....	73-74
Concinnity™ Wardrobes.....	75
Concinnity™ Storage Towers.....	76
Concinnity™ Bookcases.....	77
Concinnity™ Components	78-79
Concinnity™ Components — Worksurfaces.....	80-83
Concinnity™ Components — Supports.....	84
Concinnity™ Components.....	85
Concinnity™ Components — Modesty/Back Panels.....	86-88
Concinnity™ Modesty/Back Panels.....	89

Concinnity™ Components — Supports.....	90
Concinnity™ Kneespace Clearance End Panels.....	91
Concinnity™ Components — Supports.....	92-96
Concinnity™ Height Adjustable Bases.....	97
Concinnity™ Components — Privacy Screens.....	98
Concinnity™ Privacy Screens.....	99
Concinnity™ Components — Supports.....	100-103
Concinnity™ Components — Pedestal Tops.....	104
Concinnity™ Components — Pedestal Back Panels.....	105
Concinnity™ Accessories.....	106-107
Concinnity™ Accessories — Cable Management & Electrical.....	108-109
Concinnity™ Accessories — Paper Organizers.....	110
Concinnity™ Paper Organizer Compatibility.....	111
Concinnity™ Accessories — Lock Kits.....	112
Concinnity™ Accessories — Task Lights.....	113
Concinnity™ Accessories.....	114-116
Foundation™	117
Foundation™ Typicals.....	118-119
Foundation™.....	120-125
Foundation™ Conference Tables.....	126
Foundation™ Worksurfaces.....	127
Foundation™ Height Adjustable Bases.....	128
Foundation™ Accessories.....	129-130
Manage® Series	131
Manage® Series Laminate Desks Worksurfaces.....	132
Manage® Series Laminate Desks.....	133
Manage® Series Accessories.....	134-135
Valido®	136
Valido® Ordering Information	137
Valido® Typicals.....	138-140
Valido® Laminate Modular Desks.....	141
Valido® Modular Credenzas.....	142
Valido® Modular Returns.....	143
Valido® Laminate Modular Components.....	144-145
Valido® Laminate Wood Desks — Full Pedestals.....	146-147
Valido® Laminate Wood Desks — 3/4 Pedestals.....	148-149
Valido® Shared Components & Accessories.....	150-166
Valido® Accessories.....	168-169
Voi®	170
Voi® Ordering Information	171
Voi® Laminate Typicals.....	172-178
Voi® Bundles Typicals.....	179-181
Voi® Specifying/Design Guide	182-186
Voi® Laminate Worksurfaces — Rectangle.....	187-189
Voi® Worksurface Supports.....	190-192
Voi® Standing-Height Worksurface Supports.....	193
Voi® Standing-Height Laminate Support.....	194
Voi® — Coordinate™ Sit-to-Stand Worksurface Supports.....	195
Voi® Height Adjustable Bases.....	196
Voi® Laminate Support/Support Pedestals.....	197
Voi® Laminate Support/Support Storage.....	198
Voi® Modesty Panels.....	199-200
Voi® Privacy Screens.....	201-203
Voi® Laminate Overhead Storage.....	204
Voi® Laminate Overhead and Stack-on Storage.....	205

Voi® Laminate Shared Overhead Storage Components.....	206
Voi® Overhead Storage Supports/Accessories.....	207
Voi® Laminate Stack-on Storage — Built-up.....	208
Voi® Laminate Low Credenzas.....	209-210
Voi® Laminate Low Footed Credenzas.....	211-212
Voi® Laminate Credenzas.....	213
Voi® Laminate Mobile Storage.....	214
Voi® Laminate Storage.....	215
Voi® Laminate Storage Cubes.....	216
Voi® Laminate Storage Cube Bundles.....	217
Voi® Laminate Storage Towers.....	218-220
Voi® Laminate Storage.....	221
Voi® Laminate Bookcases.....	222
Voi® Accessories.....	223-230
Voi® Software Electrical Components.....	231
Voi® Electrical Components.....	232-233
10500 Series™	235
10500 Series™ Ordering Information	236-237
10500 Series™ Typicals.....	238-240
10500 Series™ Bundles Typicals.....	241-243
10500 Series™ Laminate Modular Components.....	244-248
10500 Series™ Worksurfaces.....	249
10500 Series™ Worksurface Supports.....	250-253
10500 Series™ Components — Supports.....	254
10500 Series™ Height Adjustable Bases.....	255
10500 Series™ Shared Components.....	256-257
10500 Series™ Laminate Modular Components.....	258-260
10500 Series™ Laminate Wood Desks — Full Pedestals.....	261-262
10500 Series™ Laminate Wood Desks — 3/4 Pedestals.....	263-264
10500 Series™ Shared Components & Accessories.....	265-273
10500 Series™ Storage.....	274
10500 Series™ Shared Components & Accessories.....	275-283
10500 Series™ Laminate Occasional Tables.....	284
10500 Series™ Shared Components & Accessories.....	285-288
10500 Series™ Accessories.....	289-290
10700 Series™	292
10700 Series™ Ordering Information	293
10700 Series™ Typicals.....	294-296
10700 Series™ Bundles Typicals.....	297-299
10700 Series™ Laminate Modular Components.....	300-305
10700 Series™ Laminate Wood Desks — Full Pedestals.....	306-307
10700 Series™ Laminate Wood Desks — 3/4 Pedestals.....	308-309
10700 Series™ Shared Components and Accessories.....	310-322
10700 Series™ Accessories.....	323-324
94000 Series™	325
94000 Series™ Typicals.....	326-327
94000 Series™ Laminate Wood Desks.....	328-333
94000 Series™ Accessories.....	334-336

For information regarding HON registered and unregistered trademarks, please go to hon.com/protected-marks. Haworth®, Herman Miller®, Knoll®, and Steelcase® are registered trademarks of their respective owners and use of the marks do not imply affiliation or endorsement of The HON Company or its products.

LIST PRICER

Effective Date: January 2020

- All illustrations and specifications in this publication are based on the latest product information available at the time of print. For the most recent version, please go to <https://www.hon.com/pricer>.
- Software support packages furnished to the customer, either by The HON Company or by another source, which support the sale of HON products are superseded by printed price lists.
- All dimensions shown in this publication are nominal.
- Pricing is subject to change without notice.

- All orders are subject to prices in effect at the time of order.
- Ordering information appears at the beginning of a section complete with examples on how to specify. These specifying information pages are referenced at the bottom center of product pages.
- HON Full Lifetime Warranty applies unless otherwise noted.
- HON nationwide customer service:
Phone: (800) 833-3964

HON LIST PRICER

Table of Contents

Mentor®	337	Systems Paper Management Support Bar.....	429	Empower® Center Screens Frosted Glass.....	496
Mentor® Ordering Information	338	Systems Paper Management Accessories.....	430	Empower® Modesty Panels/End of Run Screens.....	497
Mentor® Steel Desks.....	339-340	Abound® Tiles.....	431	Empower® Typical.....	498
Mentor® Accessories.....	341-344	Abound® Painted Metal Tiles.....	432	Empower® Height Adjustable Typical.....	499
Metro Classic	345	Abound® Custom Material Bracket Kit.....	433	Empower® Electrical Specifying	
Metro Classic Ordering Information	346	Abound® Gallery Panels — Wing.....	434, 434A	Information	500-503
Metro Classic Steel Desks.....	347-348	Abound® Gallery Panels — Wing, Accepts		Empower® Electrical and Data.....	504-505
Metro Classic Accessories.....	349-353	Glass	435, 435A	Empower® Electrical Accessories.....	506
34000 Series	354	Abound® Gallery Glass.....	436	Empower® — Voi® Laminate Low Credenzas.....	508-509
34000 Series Ordering Information	355	Abound® Gallery Connector Kits.....	437	Empower® — Voi® Laminate Mobile Storage.....	510
34000 Series Steel Desks.....	356	Abound® Gallery Panel.....	438	Empower® — Voi® Laminate Storage Towers.....	511-512
34000 Series Accessories.....	357-360	Accelerate®	440	Empower® — Contain® Metal Credenzas.....	513
38000 Series™	361	Accelerate® Ordering Information	441	Empower® — Contain® Footed Metal Credenzas.....	514
38000 Series™ Ordering Information	362	Accelerate® Fabric Patterns & Codes	442-443	Empower® — Contain® Metal Credenzas with	
38000 Series™ Typical — 3/4 Height Pedestals.....	363	Accelerate® Typical.....	444-445	Laminate Fronts.....	515
38000 Series™ Typical — Modular.....	364	Accelerate® Panels Overview.....	446-447	Empower® — Contain® Footed Metal Credenzas	
38000 Series™ Bundles Typical.....	365-366	Accelerate® Working with Panels.....	448	with Laminate Fronts.....	516
38000 Series™ Steel Desks — 3/4 Pedestals.....	367	Accelerate® Connector Overview.....	449	Empower® — Contain® Metal Credenzas	
38000 Series™ Modular Desks.....	368	Accelerate® Tackable Raceway Panels.....	450	Accessories.....	517
38000 Series™ Shared Components and		Accelerate® Top-Tier Glass Panels.....	451	Empower® — Contain® Metal Personal Towers.....	518
Accessories.....	369	Accelerate® Panel Door.....	452	Empower® — Contain® Metal Side Access Towers.....	519
38000 Series™ Accessories.....	370-373	Accelerate® Top Caps.....	453	Empower® — Contain® Metal Personal Towers	
38000 Series™ Steel Stack-on Units.....	374-376	Accelerate® Stacking Panels.....	454-455	with Laminate Fronts.....	520
		Accelerate® Frameless Glass.....	456	Empower® — Contain® Metal Side Access Towers	
		Accelerate® Connectors.....	457	with Laminate Fronts.....	521
		Accelerate® Variable Height Finished End		Empower® — Contain® Footed Metal Personal	
		and Wall Starter Kits.....	458	Towers.....	522
		Accelerate® Bracket Kits and Stability Feet.....	459	Empower® — Contain® Footed Metal Side Access	
		Empower®	461	Towers.....	523
		Empower® Fabric Screens — All Panel		Empower® — Contain® Footed Metal Personal	
		Models	462-463	Towers with Laminate Fronts.....	524
		Empower® Finish Options	464	Empower® — Contain® Footed Metal Side Access	
		Empower® Step-by-Step Guide	465	Towers with Laminate Fronts.....	525
		Empower® 72"W Typical with 24"D		Empower® — Contain® Metal Pedestals.....	526
		Worksurfaces.....	466-468	Empower® — Contain® Footed Metal Pedestals.....	527
		Empower® 60"W Typical with 24"D		Empower® — Contain® Metal Pedestals with	
		Worksurfaces.....	469-470	Laminate Fronts.....	528
		Empower® 72"W Typical with 30"D		Empower® — Contain® Footed Metal Pedestals	
		Worksurfaces.....	471-472	with Laminate Fronts.....	529
		Empower® 60"W Typical with 30"D		Empower® — Flagship® Mobile Pedestals.....	530
		Worksurfaces.....	473-474	Empower® Workplace Tools.....	531
		Empower® 120° Workstation Typical.....	475-476	Empower® Accessories.....	532
		Empower® 72"W Height Adjustable Typical		Systems Shared Components	533
		with 24"D Worksurfaces.....	477-478	Systems Overhead and Shelves Specifying	534-535
		Empower® 60"W Height Adjustable Typical		Systems Overhead and Shelves.....	536
		with 24"D Worksurfaces.....	479-480	Systems ETA Overheads and Shelves.....	537
		Empower® 72"W Height Adjustable Typical		Systems Overhead Storage.....	538
		with 30"D Worksurfaces.....	481-482	Systems Laminate Front Overhead Storage.....	539
		Empower® 60"W Height Adjustable Typical		Voi® Overhead Storage.....	540-541
		with 30"D Worksurfaces.....	483-484	Voi® Overhead and Stack-on Storage.....	542
		Empower® Legs for Linear Applications.....	485	Voi® Shared Overhead Storage Components.....	543
		Empower® Legs for 120° Applications.....	486	Systems Overhead and Shelves.....	544
		Empower® Support Beams.....	487	Systems Accessories.....	545-546
		Empower® Wire Troughs.....	488	Abound® Electrical and Data.....	547-549
		Empower® Return Components.....	489	Accelerate® Electrical and Data.....	550-551
		Empower® Systems Worksurfaces.....	490, 493	Systems Electrical and Data.....	552
		Systems Worksurfaces — 120 Degree Corner.....	491	Systems Electrical Specifying Information	553-555
		Empower® Height Adjustable Bases.....	492	Working with Cable Management.....	556
		Empower® Side Screens.....	494	Systems Electrical Components.....	557-562
		Empower® Center Screens Fabric.....	495	Systems Electrical and Data.....	564

For information regarding HON registered and unregistered trademarks, please go to hon.com/protected-marks. Haworth®, Herman Miller®, Knoll®, and Steelcase® are registered trademarks of their respective owners and use of the marks do not imply affiliation or endorsement of The HON Company or its products.

LIST PRICER

Effective Date: January 2020

- All illustrations and specifications in this publication are based on the latest product information available at the time of print. For the most recent version, please go to <https://www.hon.com/pricer>.
- Software support packages furnished to the customer, either by The HON Company or by another source, which support the sale of HON products are superseded by printed price lists.
- All dimensions shown in this publication are nominal.
- Pricing is subject to change without notice.
- All orders are subject to prices in effect at the time of order.
- Ordering information appears at the beginning of a section complete with examples on how to specify. These specifying information pages are referenced at the bottom center of product pages.
- HON Full Lifetime Warranty applies unless otherwise noted.
- HON nationwide customer service:
Phone: (800) 833-3964

HON LIST PRICER

Table of Contents

Systems Working with Worksurfaces and Supports.....565-567	Contain* Metal Credenzas Accessories.....634-635	Between™ Tables690
Systems Worksurfaces — Primary.....568-569	Contain* Metal Personal Towers636	Between™ Ordering Information691
Systems Worksurfaces — Wedge.....570	Contain* Metal Side Access Towers637	Between™ Table Tops692
Systems Worksurfaces — Corner.....571-572	Contain* Metal Personal Towers with Laminate Fronts638	Between™ Table Bases693
Systems Worksurfaces — 120 Degree Corner.....573	Contain* Metal Side Access Towers with Laminate Fronts.....639	Between™ Rectangular Table Tops.....694
Systems Worksurfaces — Corner Cove574-575	Contain* Footed Metal Personal Towers640	Between™ Table Bases for Rectangular Tops694
Systems Worksurfaces — Jetty / Peninsula.....576	Contain* Footed Metal Side Access Towers641	Between™ Nesting Tables.....695
Systems Worksurfaces — Half-Round / Quarter Round / 60° Wedge577	Contain* Footed Metal Personal Towers with Laminate Fronts.....642	Between™ Shared Components.....695
Systems Countertops — Straight and Corner...578-579	Contain* Footed Metal Side Access Towers with Laminate Fronts.....643	Between™ Accessories.....696
Systems Shelves — Corner Shelves.....580	Contain* Metal Pedestals644	Build™697
Coordinate™ Height Adjustable Bases581	Contain* Footed Metal Pedestals645-646	Build™ Ordering Information698
Coordinate™ Accessories582	Contain* Metal Pedestals with Laminate Fronts.....647	Build™ Configurations.....699-705
Coordinate™ Worksurfaces583-585	Contain* Footed Metal Pedestals with Laminate Fronts648-649	Build™ Tables706-709
Coordinate™ Shared Components.....586	Flagship®650	Build™ Accessories710
Systems Worksurface Supports.....587-589	Flagship® Ordering Information651	Cantilever Table712
Worksurface Brackets.....590	Flagship® Hanging and Standard Height Pedestals.....652	Coordinate™713
Systems Worksurface Supports.....591	Flagship® Mobile Pedestals.....653	Coordinate™ Height Adjustable Bases.....714-715
Standing-Height Worksurface Supports.....592	Flagship® 18" Deep Lateral Files with Drawers.....654	Coordinate™ Accessories716
Systems Standard Height Support Pedestals.....593	Flagship® Lateral File with Storage.....655	Coordinate™ Worksurfaces718-720
Voi® Laminate Support Pedestals594	Flagship® Modular Storage.....656	Systems Worksurfaces 120 Degree Corner721
Voi® Laminate Support Storage595	Flagship® Bookcases.....657	Coordinate™ Shared Components.....722
Systems Accessories — Paper Management /596	Flagship® Storage Cabinets.....658	Coordinate™ Desktop Riser & Sit-to-Stand Devices723
Systems Accessories — Task Lights597	Flamesafe™ Ordering Information659	Coordinate™ Accessories724
Systems Accessories — Electrical.....598	Flamesafe™ Fire-Resistant Files.....660	Flock®725
Systems Accessories — Monitor Arms.....600	Fuse™661	Flock® Collaborative Tables Ordering Information726
Systems Accessories — Keyboard Platforms.....601	Fuse™ Ordering Information662	Flock® Collaborative Solutions Table Specifying Information727
Systems Accessories602-603	Fuse™ Pedestals.....663	Flock® Collaborative Laminate Table Tops.....728
Versé®604	Fuse™ Mobile Pedestals.....664	Flock® Collaborative Table Bases.....729
Versé® Panel System.....605-608	Fuse™ Freestanding Pedestals665	Flock® Collaborative Tables730-731
STORAGE	Fuse™ Pedestal Cushion.....666	Flock® Collaborative Accessories.....732
Overview of Personal Storage and Pedestals609	Fuse™ Undermount Storage.....667	Foundation™ Conference Tables733
HON Lateral Files at a Glance610	Fuse™ Workplace Tools.....668	Huddle734
HON Vertical Files at a Glance611	400 Series669	Huddle Ordering Information735
Storage and Files Ordering Information612	400 Series Lateral Files670	Huddle Multi-Purpose Tables736
Brigade®613	Vertical Files671	Huddle Typicalsa737-738
Brigade® Ordering Information614	Vertical Files Ordering Information672	Huddle Multi-Purpose Table Tops739-740
Brigade® Standard Height Pedestals615	210 Series Vertical Files — 28½"D673	Huddle Multi-Purpose Table Bases.....741
Brigade® 800 Series Lateral Files w/Drawers616	310 Series Vertical Files — 26½"D674	Huddle Table Accessories.....742
Brigade® 800 Series Lateral Files w/Storage617	510 Series Vertical Files — 25"D675	Cable Management742
Brigade® 700 Series Lateral Files w/Drawers.....618	Lateral File Accessories.....676	Interlink IQ Electrical743
Brigade® 700 Series Lateral Files w/Storage619	Vertical File Accessories.....677	4-Trac Hardwire Electrical System.....744-745
Brigade® 600 Series Lateral Files w/Drawers620	Mobile Pedestals.....678	Huddle Power and Cable Management.....746
Brigade® Metal Dividers.....621	Pedestal Accessories.....679-680	Occasional Tables747
Brigade® Steel Bookcases.....622	Laminate Bookcases681	Laminate Occasional Tables Options748
Brigade® Storage Cabinets623	Bookcases Ordering Information682	Laminate Occasional Tables.....749
Contain®624	10500 Series™ Laminate Bookcases683	Laminate Contemporary Occasional Tables.....750
Contain® Ordering Information625	1870 Series Laminate Bookcases.....684	Motivate®751
Contain® Metal Storage626	TABLES	Motivate® Tables Specifying Information752
Contain* Metal Credenzas.....627	Arrange®685	Motivate® Fixed Height Tables.....753
Contain* Footed Metal Credenzas.....628	Arrange® Café Tables Ordering Information686	Motivate® Nesting Tables.....754
Contain* Metal Credenzas with Laminate Fronts629	Arrange® Café Table Tops.....687	Motivate® Adjustable Height Tables.....755
Contain* Footed Metal Credenzas with Laminate Fronts630	Arrange® Café Table Bases.....688	Motivate® Shared Components.....756-757
Contain* Personal Files.....631	Arrange® Café Accessories.....689	Interlink IQ Electrical758
Contain* Lateral Files632		4-Trac Hardwire Electrical System.....759-760
Contain* Lateral File Accessories.....633		Optional Electrical Accessories.....761

For information regarding HON registered and unregistered trademarks, please go to [hon.com/protected-marks](https://www.hon.com/protected-marks). Haworth®, Herman Miller®, Knoll®, and Steelcase® are registered trademarks of their respective owners and use of the marks do not imply affiliation or endorsement of The HON Company or its products.

LIST PRICER

Effective Date: January 2020

- All illustrations and specifications in this publication are based on the latest product information available at the time of print. For the most recent version, please go to <https://www.hon.com/pricer>.
- Software support packages furnished to the customer, either by The HON Company or by another source, which support the sale of HON products are superseded by printed price lists.
- All dimensions shown in this publication are nominal.
- Pricing is subject to change without notice.

- All orders are subject to prices in effect at the time of order.
- Ordering information appears at the beginning of a section complete with examples on how to specify. These specifying information pages are referenced at the bottom center of product pages.
- HON Full Lifetime Warranty applies unless otherwise noted.
- HON nationwide customer service:
Phone: (800) 833-3964

HON LIST PRICER

Table of Contents

Preside®763	LEARNING	Coordinate™ Height Adjustable Bases.....834
Preside® Ordering Information764	Cross Reference by Application798-799	Coordinate™ Accessories.....835
Preside® Specifying Information765-770	SmartLink®800	Coordinate™ Worksurfaces.....836-837
Preside® Grommet Cutout Placement.....771	SmartLink® Ordering Information801	Coordinate™ Desktop Riser & Sit-to-Stand Devices.....838
Preside® Base Clearance Dimensions.....772	SmartLink® Specifying Information802-807	Workplace Tools Ergonomic Solutions.....839
Preside® Typicals.....773	SmartLink® Student Desks.....808	Workplace Tools Chair Mats.....840
Preside® Laminate Table Tops.....774-775	SmartLink® Value Series Student Desks.....809	Task Lights.....841-842
Preside® Laminate Tables — Bases.....776-779	SmartLink® Student Accessories.....810	Paper Management & Organizational Tools.....844-847
Preside® Collaborative Tables.....780	SmartLink® Chairs.....811-814	Power & Cable Management.....848-852
Preside® Laminate Storage.....781-782	SmartLink® Teacher Stations.....815	Healthy Workplace Tools852A-852D
Modular Components.....783	SmartLink® Value Teacher Stations.....816	
Modular Components Back Panels.....783	SmartLink® Teacher Station Accessories.....817	ACCESSORIES
Wall Mount Storage.....784-785	SmartLink® Modular Storage.....818-819	Core Removable Lock Kits.....853
Preside® Laminate Shared Components.....786	SmartLink® Modular Storage and Accessories.....820	Touch-up Paint.....854
Cable Management.....787	SmartLink® Wall Rail System.....821	
Preside® Table Power Accessories.....788-789	SmartLink® Wall Rail System Accessories.....822	BUNDLES
Preside® Laminate Tables.....790		Bundles855
Preside® Laminate Tables — Pre-defined Typicals.....791	WORKPLACE TOOLS	Voi® Bundles Typical.....856-858
66000 Series / The StationMaster®792	Workplace Tools823	10500 Series™ Bundles Typical.....859-861
66000 Series Ordering Information793	Keyboard Trays & Center Drawers Ordering Information824	10700 Series™ Bundles Typical.....862-864
66000 Series The StationMaster®.....794	Monitor Arms.....825-826	38000 Series™ Bundles Typical.....865-866
Utility Tables795	Monitor Arm Accessories & CPU Holder.....827	
Utility Tables Ordering Information796	Keyboard Trays.....828-830	INDEX
Utility Tables.....797	Corner Sleeves.....831	Cross Reference Index.....867-882
	Center Drawers.....832-833	Information on Ordering Parts.....896

For information regarding HON registered and unregistered trademarks, please go to [hon.com/protected-marks](https://www.hon.com/protected-marks). Haworth®, Herman Miller®, Knoll®, and Steelcase® are registered trademarks of their respective owners and use of the marks do not imply affiliation or endorsement of The HON Company or its products.

ADDITIONS

NEW ADDITIONS: PRODUCTS

Desks	Effective Date	Storage	Effective Date	
Concinnity™ Models: HLAM3348RR, HLAM3772RD	October 1, 2019	Fuse™ Models: HAECBH, HAEHF, HAELT, HAESC19, HAESS, HAEST, HAPGBPI96NPT, HAPGBPI99TFN, HAPGBPI99SNPT, HAPGBP236NPT, HAPGBP239TFN, HAPGBS239TFN, HAPGBS239SNPT, HAPGCP199TPN, HAPGCP239TPN, HAPGCS239TPN, HAPMAP196NFN, HAPMAP236NFN, HAPMBPI96NPT, HAPMBPI99TFN, HAPMBPI99SNPT, HAPMBP236NPT, HAPMBP239TFN, HAPMBS239TFN, HAPMBS239SNPT, HAPMCP199TPN, HAPMCP239TPN, HAPMCS239TPN, HAUFHL15N, HAUFHR15N, HAUF015N		October 2019
Voi® Models: HLSL15-SDDLCC, HLSL15-SODLOC, HLSL15-SOO, HLSL15-SOODDLOC, HLSL15-SOOOLO, HLSL1512LSCL, HLSL1512LSCR, HLSL1512LSO, HLSL154LSD, HLSL154LSO, HLSL2016FP2, HLSL2030LD0F, HLSL2030LD1F, HLSL2030LD2F, HLSL2036LD0F, HLSL2036LD1F, HLSL2036LD2F, HLSL2060LD0F, HLSL2060LD2F, HLSL2060LD4F, HLSL2060LL2F, HLSL2060LR2F, HLSL2060S4F, HLSL2072LD0F, HLSL2072LD2F, HLSL2072LD4F, HLSL2072LL2F, HLSL2072LR2F, HLSL2072S4F, HLSL28AM2, HLSL28AW2, HLSL4AM2, HLSLR1330, HLSLR1336, HLSLR1345, HLSLR2448J, HLSLR2460J, HLSLR2472J, HLSLR3048J, HLSLR3060J, HLSLR3072J, HLSLSB, HLSLW045LF, HLSLW045RF, HLSLW084L, HLSLW084LF, HLSLW084R, HLSLW084RF, HLSLW085LF, HLSLW085RF, HLSLW445LF, HLSLW445RF, HLSLW485LF, HLSLW485RF	August 29, 2019	Workplace Tools	Effective Date	
10500 Series™ Models: H105076, H105077, H1052441LEP, H10524TSUPP, H1053041LEP, H105310, H105367, H105368, H105973R, H105974L, H105975R, H105976L, H105B2460, H105R2430, H105R2436, H105R2478, H105R2484, H105R3078, H105R3084, HLAM3348RR, HLAM3772RD, HLAMMP6030, HLAMMP7230, HLAMSHB30	October 1, 2019	CPU Holder Model: HCPU1	September 29, 2019	
		Keyboard Trays Models: HKTSLONG, HKTSMID, HKTSHORT	September 29, 2019	
		Monitor Arms Models: HMASD, HMASD-G, HMASTS, HMASTS-G, HPACSM, HPACW, HPADD, HPASD, HPATF	December 1, 2019	
Workstations	Effective Date	Finishes	Effective Date	
Abound® Models: HRABAB, HRFTAB	July 22, 2019	Paint		
Abound® Models: HRVC35GP, HRVC42GP, HRVC50GP, HRVC65GP, HRVCE, HRVCM, HRVG4224L, HRVG4224LG, HRVG4227L, HRVG4227LG, HRVG4230L, HRVG4230LG, HRVG4233L, HRVG4233LG, HRVG4236L, HRVG4236LG, HRVG4239L, HRVG4239LG, HRVG4242L, HRVG4242LG, HRVG4245L, HRVG4245LG, HRVG4248L, HRVG4248LG, HRVG4251L, HRVG4251LG, HRVG4260L, HRVG4260LG, HRVG4263L, HRVG4263LG, HRVG4275L, HRVG4275LG, HRVG5024L, HRVG5024LG, HRVG5027L, HRVG5027LG, HRVG5030L, HRVG5030LG, HRVG5033L, HRVG5033LG, HRVG5036L, HRVG5036LG, HRVG5039L, HRVG5039LG, HRVG5042L, HRVG5042LG, HRVG5045L, HRVG5045LG, HRVG5048L, HRVG5048LG, HRVG5051L, HRVG5051LG, HRVG5060L, HRVG5060LG, HRVG5063L, HRVG5063LG, HRVG5075L, HRVG5075LG, HRVGLSK, HRVGMASK, HRVTB11, HRVTB18, SPLH-ABND-GALGLSS.M482171, SPLH-ABND-GALGLSS.M482172, SPLH-ABND-GALGLSS.M482173, SPLH-ABND-GALGLSS.M482174, SPLH-ABND-GALGLSS.M482175, SPLH-ABND-GALGLSS.M482176, SPLH-ABND-GALGLSS.M482177, SPLH-ABND-GALGLSS.M482178, SPLH-ABND-GALGLSS.M482179, SPLH-ABND-GALGLSS.M482180, SPLH-ABND-GALGLSS.M482181, SPLH-ABND-GALGLSS.M482182, SPLH-ABND-GALGLSS.M482183	September 16, 2019	Brownstone P7D Fossil P28 Solar Black P8X Textured Brownstone P7J Textured Designer White PK7 Textured Loft P7L Textured Muslin P7M Textured Titanium P8V Titanium P8T	July 21, 2019 July 21, 2019 July 21, 2019 July 21, 2019 July 21, 2019 July 21, 2019 July 21, 2019 July 21, 2019 July 21, 2019	
Accelerate® Models: HEABAC, HEFTAC	July 22, 2019			

DISCONTINUATIONS

Desks	Effective Date
Manage® Model: HMNG60WKS	December 31, 2019
Valido® Models: H115205R, H115206L	December 31, 2019
10500 Series™ Models: H105313R, H105314L, H105315, H105HATPMOCH	December 31, 2019
10700 Series™ Models: H10724, H10726, H107697	December 31, 2019
Workstations	Effective Date
Abound® Models: HRVT1524ST2, HRVT1530ST2, HRVT1536ST2, HRVT1542ST2, HRVT1548ST2, HRVT1560ST2, HRVT3024ST2, HRVT3030ST2, HRVT3036ST2, HRVT3042ST2, HRVT3048ST2, HRVT3060ST2	September 30, 2019
Storage	Effective Date
H320 Series Models: HH322, HH322C, HH324, HH324C	December 31, 2019
Tables	Effective Date
Assemble™ Models: HBMPT6024MODC1, HBMPT6024MODQZ, HBMPT6024MODWH, HBMPT6024P, HBMPT60MOD, HBMPT7224MODC1, HBMPT7224MODQZ, HBMPT7224MODWH, HBMPT7224P, HBMPT72MOD	December 31, 2019
Workplace Tools	Effective Date
CPU Holder Model: HCPU	June 30, 2020
Keyboard Trays Models: H1706, H2107, H2516	June 30, 2020
Monitor Arms Models: H5210, H5220	June 30, 2020

Fabrics and Finishes	Effective Date
Laminates Blue Agave LBA1 Kiwi LKW1 Pomegranate LBG1 Tangerine LTG1	December 31, 2020
Paint Brilliant White WHIT Champagne Metallic T4 Select Models Only: Preside®: HTLHP108, HTLHP120, HTLHP144, HTLHP168, HTLHP180, HTLHP192, HTLHP216, HTLHP240, HTLHP84, HTLHP96, HTLHPB, HTLHPM	December 31, 2019
Fabric Sarto Desert SRT33 Meadow SRT25 Wheat SRT13 Tectonic Black NT10 Charcoal NT19 Chive NT78 Mariner NT90 Periwinkle NT85 Taupe NT26 Wine NT69	December 31, 2019
	December 31, 2019

HON FULL LIFETIME WARRANTY INFORMATION



FULL LIFETIME WARRANTY

YOUR HON FULL LIFETIME WARRANTY

Every time you purchase a HON product, you're making an investment in your future. We're proud to play a part in that future, and you can trust us to do our best for as long as you need us.

The HON Full Lifetime Warranty is our assurance to you that the HON desks, workstations, seating, tables, or storage you purchase will be free from defective material or workmanship for the life of the product.

In the unlikely event that any HON product or component covered by the HON Full Lifetime Warranty should fail under normal workplace use as a result of defective material or workmanship, HON shall repair or replace with comparable product (at HON's discretion), free of charge.

WHAT'S COVERED BY THE HON FULL LIFETIME WARRANTY?

Your HON Full Lifetime Warranty applies to product manufactured after January 1, 2011. All HON product lines, materials, and components are covered by the HON Full Lifetime Warranty except for the items described below.

The specific product lines, materials, and components listed below are covered under HON's Full 12-Year, Full 10-Year, and Full 5-Year Warranties (from date of purchase).

HON'S FULL 12-YEAR WARRANTY

- Electrical components (LED task lights, lamps and ballasts are not covered)
- 4-Way Stretch Mesh
- Seating controls
- Pneumatic Cylinders
- Wood Seating
- Accessories
- Laminate Surfaces
- Veneer Surfaces

HON'S FULL 10-YEAR WARRANTY

- Soothe® Patient Recliner Mechanism

HON'S FULL 7-YEAR WARRANTY

- Coordinate™ Height Adjustable Bases

HON'S FULL 5-YEAR WARRANTY

- All LED task lights
- Panel and seating textiles
- Electric Height Adjustable Bases (Including Memory Control)
- Coordinate™ Desktop Sit-to-Stand Risers
- Soothe® Patient Recliner Central Lock Mechanism
- Soothe® Patient Recliner Pivoting Arm
- Between™ Multi-Purpose Table
- Acoustic Solutions by Unika Vaev

These warranties apply to HON products sold within the United States of America, U.S. Territories, and Canada, as well as U.S. Military and Federal Agency purchases (regardless of location).

IS ANYTHING NOT COVERED?

There are a few exclusions to the HON Full Lifetime Warranty and to the 12-, 10-, and 5-year warranties. These exclusions are:

- All HON products that are covered under a separate 5-year warranty.
- Color-fastness or matching of colors, woodgrains, or textures occurring in wood, leather, or other materials that naturally exhibit inherent color variations.
- Customer's own materials (COM) selected by and used at the request of the user.
- Modifications or attachments to the product that are not approved by The HON Company and product failures resulting from such modifications or attachments.
- Product normal wear and tear, which are to be expected over the course of ownership.
- Products that were not installed, used, or maintained in accordance with product instructions and warnings.
- Products used for rental purposes.
- Damage caused by cleaning chemicals.
- Dye transfer caused by external contaminants (including clothing and accessory dyes such as those used on denim jeans) may migrate to lighter colors. This phenomenon is increased by humidity and temperature and is irreversible.
- Fabric pattern match seat to back or chair to chair. If pattern match is needed, please submit a Tailored Solutions request or contact HON Customer Support/Tailored Solutions with questions.

WARRANTY REQUESTS OR QUESTIONS?

Your HON Dealer is our mutual partner in supporting your warranty requests. To obtain service under this warranty, please contact your HON dealer. If you are not sure who your dealer is, please call HON Customer Support at 800.833.3964.

THAT'S YOUR HON FULL LIFETIME WARRANTY AS AN OWNER OF HON PRODUCT, THE WARRANTY EXPLAINED HERE IS YOUR SOLE AND EXCLUSIVE REMEDY. THERE ARE SOME EXCEPTIONS IF YOU PURCHASED THE PRODUCT FOR HOME OR PERSONAL USE WHICH ARE EXPLAINED BELOW. TO THE EXTENT ALLOWED BY LAW, THE HON COMPANY MAKES NO OTHER WARRANTY, EITHER EXPRESS OR IMPLIED, INCLUDING ANY WARRANTY OF MERCHANTABILITY OR FITNESS FOR A PARTICULAR PURPOSE. THE HON COMPANY WILL NOT BE LIABLE FOR ANY CONSEQUENTIAL OR INCIDENTAL DAMAGES.

A WORD ABOUT PURCHASES FOR HOME OR PERSONAL USE

Please note, this section only applies if you purchased your HON product for your home or for your own personal or family use. HON's warranties give you specific legal rights and you may have other rights, which vary from state to state. As a consumer purchaser, the complete exclusion of implied warranties noted in the above paragraph does not apply to you, however, to the extent allowed by applicable state law, the implied warranties are limited to the applicable term of the warranty. Some states do not allow the exclusion or limitation of incidental or consequential damages, so the above exclusion or limitation may not apply to you.

HON LIMITED 5-YEAR WARRANTY INFORMATION



LIMITED 5-YEAR WARRANTY

The HON Company promises to repair or replace HON products or components covered under this warranty that are found to be defective in material or workmanship within five (5) years from the date of original purchase so long as you, the original purchaser, still owns it. This is your sole and exclusive remedy. This warranty is subject to the provisions below. It applies to the products listed here manufactured after January 1, 2018.

LIMITATIONS:

- Upholstery on chairs is warranted for two years from date of purchase.
- Damage caused by the carrier in-transit is handled under separate terms.

EXCLUSIONS:

This warranty does not apply and no other warranty applies to:

- Normal wear and tear, which are to be expected over the course of ownership.
- Modifications or attachments to the product that are not approved by The HON Company.
- Products that were not installed, used or maintained in accordance with product instructions and warnings.
- Products used for rental purposes.

SEATING USAGE

Normal commercial use for seating is identified as the equivalent of a single shift, forty-(40) hour workweek. To the extent that a seating product is used in a manner exceeding this, the applicable warranty period will be reduced in a pro-rata manner.

A WORD ABOUT COLOR VARIATIONS, FABRICS AND FINISHES:

The HON Company does not warrant the color-fastness or matching of colors, grains or textures of covering materials.

CUSTOMER'S OWN MATERIAL (COM)

Not available on HON products covered under the HON 5-year warranty.

TO THE EXTENT ALLOWED BY LAW, THE HON COMPANY MAKES NO OTHER WARRANTY, EITHER EXPRESS OR IMPLIED, INCLUDING ANY WARRANTY OF MERCHANTABILITY OR FITNESS FOR A PARTICULAR PURPOSE. THE HON COMPANY WILL NOT BE LIABLE FOR ANY CONSEQUENTIAL OR INCIDENTAL DAMAGES.

NOTICE TO PURCHASERS FOR HOME OR PERSONAL USE:

Federal law does not permit the exclusion of certain implied warranties for consumer products. Therefore, if you are purchasing this product for home or personal use, the exclusion of implied warranties noted in the above paragraph does not apply to you. Some states do not allow the exclusion or limitation of incidental or consequential damages, so the above limitation or exclusion may not apply to you. This warranty gives you specific legal rights, and you may also have other rights which vary from state to state.

This warranty applies only to products sold within the United States of America and the Commonwealth of Canada.

TO OBTAIN SERVICE UNDER THIS WARRANTY:

Your HON® Dealer is our mutual partner in supporting your warranty requests. By following the procedures outlined below, you can be assured of the best level of service. Please note: Consent of The HON Company must be obtained before any warranty work is performed. To obtain consent, please take the following steps:

1. Contact the Dealer from whom the product was purchased within 30 days of discovery of the defect. Be prepared to affirm that you are the original purchaser of the product and to provide the serial number(s) from the product in question.
2. Your Dealer will gather all pertinent information regarding the claim, inspect the product and contact a HON Company customer service representative. (Please allow a reasonable amount of time for inspection and review.)
3. If The HON Company affirms that the product in question is eligible under the conditions of the warranty as stated above, the customer service representative or another representative of the Company will determine whether to provide replacement parts, authorize repairs or replace the product.

ORDERING INFORMATION

ORDERING

Electronic ordering is the standard order process for HON. HON supports the following primary methods for the electronic transmission of orders and order related documents:

Electronic Ordering

Available in the HONReady portal at honready.hon.com. There are multiple options available for processing orders electronically.

Integration with the standard Office Furniture business systems or other pre-approved proprietary software packages.

SIF file upload using fully optioned SIF files into the electronic ordering applications.

Manual entry of line items into the electronic ordering application.

EDI-System to System Integration

With standard Office Product systems or other pre-approved proprietary software systems.

Training, technical set-up and support is available through our Dealer Operations Team at honready@honcompany.com.

ORDER REQUIREMENTS

- Customer must provide complete and correct information, including complete model number, finishes, colors, options, and quantity.
- If a bid quotation or other special pricing applies, such information must be clearly stated on the order with applicable bid number or contract number.
- Order Management contact name and phone number.
- Delivery Appointment contact name and phone number at the dealership or installation company. HON does not accept orders with end user appointment contacts.
- Dealer Sales Representative, primary or multiple DSRs.
- “Best Date Available” for the entire order is standard service for HON. If eligible, other Date Requests may be requested and must be submitted with the order. Other Date Requests are subject to review by HON prior to acceptance:
 - “Ship After” requests are eligible on all order sizes
 - “Deliver On” requests are eligible for full truckload orders
- Additional services outside of HON’s standard services may be available through HON’s ‘Enhanced Services’ for a corresponding fee. Requested services from ‘Enhanced Services’ must be provided at time of order placement.
- The Company reserves the right to require electronic orders or charge \$50 fee per Purchase Order (PO) for manual order processing.
- Failure to provide complete and accurate information results in delayed order entry and acknowledgment. Incomplete orders will not be produced and will be returned to Dealer for correction.

ACKNOWLEDGMENT SERVICE

- E-mailed acknowledgments are available by customer request.
- An acknowledgment will be emailed the morning of the next business day, unless order is placed on credit or other order hold.
- The order will not receive an acknowledged shipment date until all order holds are released.

ORDER CHANGES OR CANCELLATIONS

For Order Changes or Cancellations, please contact Customer Support at 800-833-3964 or email OrderChanges@honcompany.com.

TERMS AND CONDITIONS

See **HON NOW** on honready.hon.com for more information about HON NOW delivery, services and ordering information.

INTEGRATED DESIGN SOLUTIONS

HON INTEGRATED DESIGN SOLUTIONS

Need design assistance? We can help! Our expert design staff will create a professional design package that is sure to put you one step ahead of the competition. And the best part is – it's free!

AUDIT

We will check your drawing and parts list for accuracy. We verify quantity, specification accuracy, product compatibility and structural support.

PLAN & SPECIFY

We will provide a professional design package including a CAD furniture plan, 3-D line drawing and complete parts list based on the rough sketch and work order forms you supply.

VALUE ENGINEERING

We will optimize workstation layouts and propose potential cost saving measures to help your customer save money and make you more competitive and profitable.

RENDERING

We will create a photo realistic rendering of your furniture plan to help your customer visualize what their desired office space will look like.

*SPACE PLANNING (BILLABLE SERVICE)

Let our team do the creative work for you. Our low rates and expert staff will create a furniture layout and design that best suits your customer.

PLANNING TYPICALS

Quick planning ideas to share with your clients. Various settings showcasing desks, tables and workstations available in multiple formats. View them today under Design Resources on the HON Ready Portal.

CONTACT INTEGRATED DESIGN SOLUTIONS

Questions? Please reach out to your region's dedicated designer. Not sure how to reach your designer? Send us a note at the email below.

E-Mail: integrateddesign@honcompany.com



Solve® Chair shown with Coordinate™ Height-Adjustable Table.

MyProjects

A place for all HON Project Services

MyProjects provides one platform to access the full portfolio of HON services including:

- Plan & Specify
- Audit
- Product Modification
- Special Laminates
- Value Engineering
- Rendering
- Customer's Own Material
- Dual Fabric Applications
- Space Planning
- Special Paints
- Project Bid Pricing

Submit your request on the HON Ready Portal at honready.hon.com, MyProjects.

MyProjects Lead Time: 1-3 business days depending on complexity and size of your project.

TAILORED SOLUTIONS ORDERING INFORMATION

PRODUCT MODIFICATIONS

Modifications include structural and dimensional modifications to existing product and Dual Fabric Applications, when standard model is not available.

The HON Company, at its own discretion, may modify standard products to meet specific needs. Product specials can be requested on HON brand product only.

List prices contained in published list pricers are for standard catalog items only. Changes or alterations to catalog items other than those listed as catalog options are subject to additional charges. Pricing will only be furnished upon approval of the special request.

Requests to have the product produced in more than one fabric (e.g., fabric on the seat is different than the fabric on the back), are considered a Dual Fabric Applications request and follow the Product Modification request process within MyProjects.

SPECIAL LAMINATES

Special laminates include requests for laminates not available as part of The HON Company's standard offering. Requests for special laminates are subject to manufacturing approval and minimum order quantities. The HON Company approved special laminates will be subject to a designated upcharge per unit.

Requests for special laminates should be submitted through the MyProjects Application on the HON Ready portal. Pricing will only be furnished upon approval of the special request.

SPECIAL PAINTS

- The HON Company's paint matching equipment can match almost any color, excluding some metallic and whites.
- Special paint requests must be submitted on the HON Ready Portal MyProjects application.
- In order to request a paint sample, the customer must have a minimum order of 10 like product units. Any requests with less than that amount will not be processed.
 - For each new paint request, there will be a \$500 net charge. A sample of the exact color desired is required for matching and approval. The HON Company will match the color and provide a production sample for the customer to review and approve.
 - If the customer is requesting a paint that has been previously matched, a painted match sample is provided with a \$100 net charge.

- Once the signed paint sample is received at The HON Company, the request will be approved.
- Each unique color or finish combination incurs a designated upcharge per color per order (all standard discounts/competitive project pricing applies).

Special note: Some special colors could fall outside of this program due to production costs or not meeting The HON Company's quality standards. The HON Company may apply additional charges to some colors which are costly to apply, and refuse some orders on colors that cannot meet The HON Company's high quality standards. The HON Company will notify the customer upon completion of The HON Company's evaluation if a change in price is required or rejection of the order.

DISCONTINUED PRODUCT

Requests for discontinued product require engineering evaluation, safety review, and testing to current standards prior to approval. Many discontinued products are not available for order. Requests for discontinued products should be submitted through the MyProjects Application on the HON Ready portal.

LEAD TIMES FOR SPECIALS PRODUCT

Lead times on orders containing specials are subject to production capacity and material availability. When possible, the customer should order special products separately to avoid extended lead times for standard products. Extended lead times will be noted on the specials request.

CHANGES TO SPECIALS PRODUCT

A special model will be provided for each approved special item to process orders. Once an order is placed, no changes or cancellations can be made to the order without approval from Tailored Solutions.

CONTACT TAILORED SOLUTIONS

Phone: 800.833.3964 and listen for Tailored Solutions offering on the menu.

Email: HONSpecials@honcompany.com

CUSTOMER'S OWN MATERIAL ORDERING INFORMATION

CUSTOMER'S OWN MATERIAL (COM) PROGRAM

Customer's Own Material (COM) is a request to use fabrics not available as part of HON's standard fabric offering. Manufacture to Supply (MTS) and Dealer to Supply (DTS) are the two ordering methods. The HON Company has partnered with fabric manufacturers to provide competitive pricing and selection through the MTS program. MTS will be the standard offering unless The HON Company is unable to procure the fabric. If there is a DTS request submitted, The HON Company will advise at the time of the request if DTS is available.

CUSTOMER WARRANTY EXCLUSION

The HON Company shall have no responsibility for the condition, quality, value, performance, physical properties, or any other aspects of the COM.

The HON Company shall have no liability for any damages, injuries, or losses to the customer or to any third party that shall be caused by any COM or product modification, and the customer shall hold The HON Company harmless for all liability.

The HON Company assumes no responsibility for the overall appearance, flammability, normal durability, colorfastness, or any other quality of the COM or product modification after its application on a HON product beyond normal quality standards. The HON Company reserves the right to reject a COM fabric if the quality of the COM is not satisfactory for the product. Should this occur, the customer will be notified with an explanation of the issue.

The HON Company is not responsible for fabric that has become obsolete at the COM supplier, that is of poor quality, or that is delivered late to The HON Company from the COM supplier. The HON Company is not responsible for excess yardage created by DTS orders and reserves the right to dispose of the excess fabric.

As a standard HON does not pattern match any standard, partnership or COM fabric, therefore pattern match is not applicable under warranty. If pattern match is needed please submit a Tailored Solutions request or contact HON Customer Support/Tailored Solutions once your COM has been approved.

COM TESTING

As a result of recent legal requirements, The HON Company will need to obtain specific information from the fabric supplier about treatments and chemicals used in the fabric. To the extent the supplier is unwilling or unable to provide the necessary information, which could extend the testing lead time of the request.

To check if a COM has been tested previously, utilize the COM Search Tool on the HON Ready Portal > Design Resources > Textiles & Finishes section using the following information:

- COM Supplier's Name
- Fabric Pattern Name
- Color Name
- If the COM fabric has been tested and previously approved, the COM will not need to be re-tested unless testing

standards have changed, fabric is to be used on a different series, or direction of the fabric has changed from what was previously approved. Please note that Panel product must be approved for each model and color.

- If the pattern has previously been tested and approved, but not in the specific requested color, the customer will need to request an order code for that color only. No further testing will be necessary since the pattern has already been approved.

If the fabric has not previously been tested, the customer must enter the COM request on the HON Ready Portal > Textiles & Finishes > COM Search Tool.

Complete the Supplier Name, Pattern, and Color drop-down fields. For quicker results in these fields, type the first letter of the (supplier, pattern, color) name and, when done, click Add and then Submit. (Multiple series can be added to the same request if they are the same supplier, pattern, and color.)

An email will be sent to the requestor stating the COM Request was successfully submitted. Up to four emails could be received: submitted, in testing, testing materials requested, and final approval/denial with price grade and fabric code. The testing process takes approximately 48 hours.

COM yardage in the pricer is shown as pattern cut only.

COM TESTING — CAL 133 TESTING INFORMATION

The customer is responsible for ensuring that the COM fabric is certified to meet all flame-retardant requirements. All COM seating fabric must, at minimum, meet CAL 117 requirements. If the customer requires the chair be tested to meet the fire safety standards of CAL 133, additional testing and information is required.

All CAL 133 requests must be submitted through the MyProjects application on the HON Ready Portal. Each request must be entered separately since each request will need to be tested individually.

Once the supplier provides the requirements to The HON Company, testing will begin. The customer will receive approval or denial information upon completion of testing.

If the test is approved, a specific model number including "FC" at the end will be provided with an appropriate price.

MTS COM

As previously mentioned, MTS is the primary COM method.

If the COM fabric has not been tested, a COM request must be submitted on the HON Ready Portal.

For MTS orders, The HON Company will procure fabric needed for production. Should The HON Company not be able to obtain fabric yardage, the customer will be contacted.

CUSTOMER'S OWN MATERIAL ORDERING INFORMATION

When testing has been completed, the customer will be notified by the COM team of the test results. If the COM is approved, The HON Company will provide a COM tracking order code for MTS. That tracking code is required on the order in place of the standard fabric code.

If approved, MTS product will be assigned an appropriate fabric grade for pricing. The pricing can be found on the HON Ready Portal > Design Resources > Textiles & Finishes. (All standard discounts/competitive project pricing applies).

Written COM price quotes are valid for 90 days after the issue date.

DTS COM

DTS COM is only available if the COM fabric cannot be procured by The HON Company. If the fabric can be procured by The HON Company, the customer will be contacted to switch to MTS or cancel the request.

If your fabric is not listed as approved, and it is not a Partnership fabric you may request a "Dealer to Supply" code. Select the "Request COM Test" link on the COM Search website. Complete the Supplier Name, Pattern, and Color drop-down fields. For quicker results in these fields, type the first letter of the (supplier, pattern, color) name and, when done, click Add and then Submit. (Multiple series can be added to the same request if they are the same supplier, pattern, and color.)

An email will be sent to the requestor stating the COM Request was successfully submitted. Up to four emails could be received: submitted, in testing, testing materials requested, and final approval/denial with price grade and fabric code. It's rare actual test yardage is required. Testing is mainly done by reviewing the attributes of the fabric. The testing process takes approximately 48 hours.

If the COM has not been tested, a COM request must be submitted on the HON Ready Portal > Design Resources > Textiles & Finishes.

When testing has been completed, the customer will be notified by the COM team of the test results. If the COM is approved, The HON Company will provide a COM tracking order code. That tracking code is required on the order in the place of the standard fabric code.

DTS product is priced at the following grades (all standard discounts/competitive project pricing applies):

- Chairs are a Grade 4
- Panel product is a Grade D

Written COM price quotes are valid for 90 days after the issue date.

COM LEAD TIME

Ship dates will be based on fabric receipt and The HON Company's standard lead time. All fabric must be properly tagged and shipped to the appropriate producing location (provided in the approval email).

- Specific to DTS orders, COM orders will not receive a ship (acknowledged) date until The HON Company has the fabric in its possession for production.
- Specific to DTS orders, the customer may send the required yardage for the order to the address listed on the approval email to arrive no sooner than 4 weeks in advance of the acknowledgment date.

HON will make every effort to locate mis-directed COM shipments on behalf of the customer. However, The HON Company will not be responsible for any COM received without a tracking number or incorrectly shipped by the fabric vendor to an incorrect producing facility.

COM ORDERING INFORMATION

The following information must appear on or accompany the product purchase order:

- Approval tracking number and the customer's purchase order number
- COM supplier, pattern, and color name/number

The packing list for the COM must include the following information when The HON Company receives the shipment for production:

- Dealer or Wholesaler Name
- Purchase order number submitted to The HON Company
- Fabric name
- Yardage shipped
- Approval ordering code

If The HON Company receives fabric with incorrect labeling that cannot be linked to an order, The HON Company will hold the fabric for up to 7 days while the COM team attempts to identify the order. After 7 days, The HON Company will return the fabric to the sender.

Specific to DTS orders; the customer should send only the amount needed for the order. Excess yardage will be disposed of at The HON Company's discretion.

CHANGES TO COM PRODUCT

Once a COM product is ordered, no changes or cancellations can be made to the COM product without approval from the HON COM team.

CONTACT COM TEAM

Phone: 800.833.3964 and listen for COM TEAM offering on the menu.

COM Email: HONCOMTeam@honcompany.com

PARTNERSHIP TEXTILE INFORMATION

Partnership Textiles is the result of The HON Company's partnership with textile industry leaders Camira, Maharam, Stinson, and Ultrafabrics, LLC. The extensive collection of design-driven textiles create a superior offering at a great value. Partnership Textiles significantly updates HON's offering, expanding it with fresh and exciting options.

- **Fabric Warranty:** Partnership Textiles are covered by HON's Full Lifetime Warranty.
- **Lead Times:** Orders specified with Partnership Textiles will be acknowledged based on the supplier's availability and delivery schedule.
- **Availability:** The HON Company will regularly introduce new Partnership Textiles and reserves the right to change the offering at any time.
- **Fabric Cards:** A curated set of Partnership Textiles are carded jointly by HON and the supplier.

Camira

- Blazer

Maharam

- Apt
- Bluff
- Collection 1
- Lariat
- Meld
- 6M

Stinson

- Edge
- Flow
- Reliance IV
- Square One

Ultrafabrics, LLC

- Brisa
- Ultraleather Pro

Fabric Memo Samples: Please contact the supplier directly:

Camira: memos@camirafabrics.com

Maharam: (800) 645-3943

Stinson: (800) 841-6279

Ultrafabrics: (877) 309-6648

HON BRANDED, PARTNERSHIP AND COM PATTERN MATCH

- **Seat to Back Pattern Match** provides alignment of patterns or stripes on chair front surfaces. Additional yardage may be required depending on pattern repeat. If Seat to Back Pattern Match is needed, please contact HON Customer Support/Tailored Solutions. Upcharges are limited to the following product series: Flock® Collaborative Seating, Grove® Seating, Invitation® Lounge Seating, Soothe® Seating.

Single Chair	\$45.00 ea. list upcharge
Two-seat Chair	\$60.00 ea. list upcharge
Three-seat Chair	\$75.00 ea. list upcharge
- **Chair to Chair Pattern Match** provides identical pattern alignment from unit to unit and is available with an upcharge. Chair to Chair Pattern Match is reviewed on a case by case basis as several factors are reviewed to determine additional yardage required, including repeat and pattern direction. If Chair to Chair Pattern Match is needed, please contact HON Customer Support/Tailored Solutions.



PAINT PROGRAM

The HON Company has established paint grades to allow customers flexibility and ease in doing business with HON. HON has three paint grades P1, P2, and P3.

P1 PAINT COLORS

HON has established P1 paints which are available on a majority of core products.

P2 PAINT COLORS

Please see individual pricer pages for eligible series and upcharges for P2 paints. P2 paints are listed in the pricer pages under the column P2. Upcharges vary by product (all standard discounts/competitive project pricing applies). No minimum quantity required.

P3 PAINT COLORS

Please see individual pricer pages for eligible series and upcharges for P3 paints. P3 paints are listed in the pricer pages under the column P3. Upcharges vary by product (all standard discounts/competitive project pricing applies). No minimum quantity required.

SPECIAL PAINT COLORS (P4-P6)

With The HON Company's state of the art color matching equipment just about any color can be matched, excluding some metallic and whites. A sample of the exact color desired is required for matching and approval.

- For each newly requested paint, a net fee of \$500 will be charged to cover costs associated with the matching process.
- For existing, previously matched paints, there is no matching fee, however there is a \$100 net fee for sample panels required for the approval process. Refer to MyProjects on the HON Portal for a list of approved special paints.

For all special paint requests, HON will send a production sample for the customer to review and approve. Once the signed paint sample is received at HON the order can be entered. Upcharges vary by product (all standard discounts/competitive project pricing applies). A quantity of 10 like-model minimum order is required for special paints. For complete program details, access Tailored Solutions on the HON Ready Portal at honready.hon.com.

Some special colors could fall outside of this program due to production costs or not meeting HON quality standards. The HON Company may apply additional charges to some colors which are costly to apply, and deny some orders on colors that cannot meet our high quality standards. We will notify the customer upon completion of our evaluation if a change in price is required or if the request is denied.

ENVIRONMENTAL STATEMENT

Clearing the air.

In 2006, The HON Company became one of the first office furniture manufacturers to have products certified under the Indoor Advantage™ program. Virtually all manufactured products emit chemical compounds into the air. Indoor Advantage™ certification helps assure customers that certified products will help improve the air quality within their offices and workspaces.

Developed by SCS Global Services, Indoor Advantage™ evaluates products against indoor air quality standards, like ANSI/BIFMA Furniture Emissions Standard, X7.1. The ANSI/BIFMA X7.1 standard allows manufacturers to test individual components, as well as complete products for emissions from volatile organic compounds (VOCs). This allows us to identify problematic materials and phase them out of our products.

Indoor Advantage™ certified products meet the LEED v4 credits for low-emitting materials.

Indoor Advantage™ offers two levels of certification, including Indoor Advantage™ and Indoor Advantage™ Gold.



On the level®.

LEVEL®, the certification program for the BIFMA e3 Sustainability Standard, was developed in response to increasing demand for proof that manufacturers were living up to their environmental claims. LEVEL® is a multi-attribute sustainability certification label for products that have met criteria in four categories of impact: Materials, Energy and Atmosphere, Human and Ecosystem Health, and Social Responsibility.

LEVEL® offers three levels of certification:



Products that meet these specifications are identified throughout this publication with the following icons:

Certified SCS Indoor Advantage™



LEVEL® certified to the BIFMA e3 Sustainability Standard

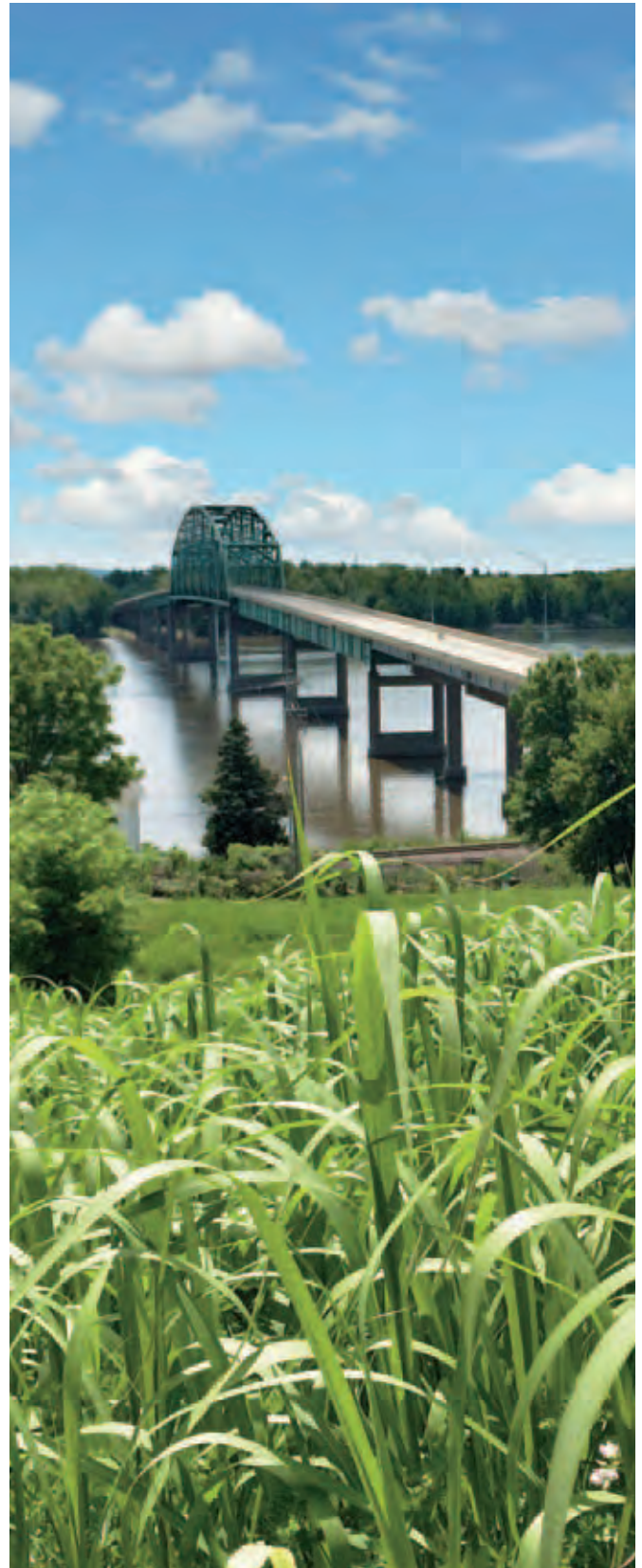

IMPORTANT INFORMATION

HON NOW™

We are inspired by the way you work. The chair you sit in. The space you choose to get it all done. We believe that well-designed office furniture should not only look good but be delivered quickly. Why wait for what you want and what you need right **NOW**?

HON NOW™ offers you a simple way to get the office solutions you need delivered with speed in mind. The office is changing and we are here to help you keep pace. No matter what space you are shopping for or product you need, HON NOW™ is made for the way you work.

GSA CONTRACT INFORMATION

Model numbers identified with the verbiage “**Open Market**” are not offered on HON’s GSA contract GS-27F-0015S. Model numbers identified with the following verbiage “Must be purchased with a configurable end product. If ordered separately, not on GSA contract” is to mean that these configurable components or options:

- Have no functionality or capability without being integrated into an end product, and
- Are not separately orderable; an eligible Schedule ordering activity may only purchase them with a configured system that is on contract.

HON CUSTOMER SUPPORT CONTACT INFORMATION

Nationwide CS Phone – (800) 833-3964

Nationwide Product Solutions Team/Phone – (800) 336-8398

Nationwide Order Entry – email: HONOE@honcompany.com

Government CS Phone – (800) 466-8694

GSA Team: HONGSATEAM@honcompany.com

GSA Order Entry: HONGSAOE@honcompany.com

Integrated Design Solutions – (800) 433-7264

HON Online Order Support – HONReady@honcompany.com

DASH (transportation and delivery assistance) – (800) 334-8057

HON Literature Fulfillment Phone – (800) 466-4808

HON Literature Fulfillment Fax – (800) 466-1865



Nationwide CS Phone

800-833-3964

THE FOLLOWING ICONS ARE USED THROUGHOUT THIS PUBLICATION

	Meets or exceeds ANSI/BIFMA and ISTA performance standards		Readily Available. For additional lead time information see page 21.
	level certified to the BIFMA e3 Sustainability Standard		Available within a “standard” or “extended” lead time. For additional lead time information see page 21.
	Certified SCS Indoor Advantage™		May have extended lead times. For additional lead time information see page 21.
	Caution		Product shipped two to a carton
	Easy to assemble		Product shipped four to a carton
	Shippable by small-package carrier		Fire Code
	Wheel-chair compatible		Core Product Line
	Soft-tread caster option available		ColorCorrect® Eligible Product
	HON “One Key” Interchangeable core removable locks (see page 853)		Product scheduled for discontinuation
	Omit core removable lock option available. Allows keyed alike workstations (see page 853).		DE-EMPHASIZED: Product or fabric/surface material is de-emphasized, effective date as noted. Not carded. View online at honready.hon.com

FABRIC PATTERNS & CODES



FABRIC PATTERNS & CODES

- For additional HON to Supply COM fabric grade pricing, go to honready.hon.com and search on the HON to Supply COM link.
- All specifications in this publication are based on the latest product information available at the time of print.
- Certain dyes (including clothing and accessory dyes such as those used on denim jeans) may migrate to lighter colors. This phenomenon is increased by humidity and temperature and is irreversible. The HON Company LLC does not assume responsibility for dye transfer caused by external contaminants.
- COM Ordering Information and pricing on page 14.
- See page 15 for Partnership Textile program information.
- All standard fabrics are carded. Cards are available through HON Literature Fulfillment.
- Remember to add an FC to the base model number when fire code fabric is selected. New Models with FC Fire Code suffix meet CA Technical Bulletin 133. See pages 26-29 of the January 2020 Seating Pricer for available models/fabrics.
- Fabrics and foam meet requirements for CAL-TB 117-2013.
- Fire Code fabrics with FC foam meet requirements for CA Technical Bulletin 133.

LEAD TIMES

THE FOLLOWING ICONS ARE USED TO DENOTE FABRIC OPTION LEAD TIMES

FABRIC/FINISH LEAD TIME INDICATOR



Fabric is readily available. Products using these fabrics will receive the best available product lead time and are a good option for standards programs as they will be in the HON portfolio for several years. Go to honready.hon.com and use **Compass** for product lead times by series.



Fabric is available within standard lead times. Products using these fabrics will receive a “standard” or “extended” lead time. The lead time will be determined by the combination of product and fabric. Go to honready.hon.com and use **Compass** for product lead times by series.



Fabric may have extended lead times. Products using these fabrics will typically have a 4+ week lead time. Go to honready.hon.com and use the **Compass** tool for product lead times by series.

HON EXPRESS QUICK SHIP PROGRAM

For the full list of products delivered in 5 business days or less, visit honready.hon.com.

PRODUCT LEAD TIMES

Standard lead times for products are between 2-4 weeks. For current exceptions to our standard lead time, go to honready.hon.com and use the **Compass** tool.

In order to establish accurate expectations for your project, please review this listing prior to submitting your purchase order.

Lead time calculation begins when order is free from any holds (i.e., bad lines, material, credit, etc.).

Please note, these production lead time estimates do NOT include delivery time. All published lead times are estimates, not guarantees of delivery.

For further information concerning lead times, please contact HON Customer Support via email HONTeamBox@honcompany or by phone at **800-833-3964**.

FABRIC PATTERNS & CODES

GRADE 1

APEX	APX
◆ Basalt	APX25
◆ Beet	APX12
◆ Blackberry	APX20
◆ Chive	APX05
◆ Iris	APX03
◆ Kiwi	APX06
◆ Lemonade	APX08
◆ Navy	APX13
◆ Papaya	APX09
◆ Pumice	APX23
◆ Rain	APX19
◆ Resort	APX15
◆ Royal	APX14
◆ Tiki	APX29
◆ Tomato	APX11

ATTIRE AI

◆ Blaze *	AI42
◆ Blue Lagoon *	AI90
◆ Crimson *	AI62
◆ Fatigue *	AI76
◆ Ivy *	AI82
◆ Lithium *	AI19
◆ Onyx *	AI10
◆ Sable *	AI49
◆ Taupe *	AI26
◆ Turquoise *	AI96

BLACK FABRIC ACCF

◆ Black	ACCF10
---------	--------

BLACK MESH ACCM

◆ Black	ACCM10
---------	--------

CENTURION CU

◆ Apricot	CU47
◆ Bark	CU25
◆ Black	CU10
◆ Espresso	CU49
◆ Fog	CU03
◆ Frost	CU22
◆ Goldenrod	CU27
◆ Indigo	CU06
◆ Iris	CU50
◆ Iron Ore	CU19
◆ Jade	CU83
◆ Marsala	CU63
◆ Morel	CU24
◆ Navy	CU98
◆ Peacock	CU97
◆ Pear	CU84
◆ Ruby	CU67
◆ Sapphire	CU09

GRADE 1 *continued*

COMPASS	COMP
◆ Beach	COMP16
◆ Bittersweet	COMP46
◆ Chocolate	COMP49
◆ Ink	COMP10
◆ Meadow	COMP82
◆ Midnight	COMP90
◆ Putty	COMP22
◆ Ruby	COMP62
◆ Sterling	COMP19
◆ Taupe	COMP26
◆ Tide	COMP96

COMPASS FOAM* COMF

◆ Bittersweet	COMF46
◆ Ink	COMF10
◆ Meadow	COMF82
◆ Midnight	COMF90
◆ Putty	COMF22
◆ Sterling	COMF19

**This fabric available for Solve* Upholstered Back models only.*

CONTOURETT POLYURETHANE UR

◆ Baltic	UR94
◆ Beach	UR23
◆ Black	UR10
◆ Bordeaux	UR63
◆ Buff	UR22
◆ Cloud	UR18
◆ Coffee Bean	UR49
◆ Crater	UR51
◆ Flame	UR62
◆ Graphite	UR19
◆ Iron	UR20
◆ Luggage	UR26
◆ Marine	UR92
◆ Navy	UR95
◆ Nimbus	UR93
◆ Ocean	UR96
◆ Pumpkin	UR42
◆ Quarry	UR24
◆ Red	UR64
◆ Safari	UR27
◆ Sage	UR82
◆ Steel	UR21
◆ Storm	UR17
◆ Taupe	UR28
◆ Trunk	UR50

GRADE 1 *continued*

DAPPER	DAPR
◆ Ash	DAPR20
◆ Azalea	DAPR95
◆ Breeze	DAPR06
◆ Canvas	DAPR25
◆ Currant	DAPR00
◆ Emerald	DAPR75
◆ Fawn	DAPR35
◆ Fern	DAPR85
◆ Jewel	DAPR08
◆ Marigold	DAPR65
◆ Onyx	DAPR10
◆ Orchid	DAPR90
◆ Peony	DAPR50
◆ Pool	DAPR05
◆ Rose	DAPR40
◆ Sapphire	DAPR07
◆ Scarlet	DAPR45
◆ Sepia	DAPR30
◆ Slate	DAPR15
◆ Sorbet	DAPR55
◆ Spice	DAPR60
◆ Spring	DAPR80
◆ Varsity	DAPR09
◆ Zest	DAPR70

ENSEMBLE ENSB

◆ Aquamarine	ENSB30
◆ Ash	ENSB39
◆ Greige	ENSB36
◆ Harbor	ENSB34
◆ Navy	ENSB35
◆ Oat	ENSB37
◆ Pear	ENSB33
◆ Sand	ENSB38
◆ Scarlet	ENSB32
◆ Slate	ENSB31
◆ Stone	ENSB40

GRADE 1 *continued*

HAMILTON	HAML
◆ Azure	HAML10
◆ Biscotti	HAML11
◆ Cabernet	HAML08
◆ Carolina	HAML21
◆ Charcoal	HAML17
◆ Chocolate	HAML13
◆ Cloud	HAML18
◆ Dane	HAML16
◆ Dusty Rose	HAML07
◆ Esmeralda	HAML06
◆ Fern	HAML04
◆ Fresh	HAML03
◆ Granola	HAML19
◆ Lilac	HAML14
◆ Lime	HAML05
◆ Lipstick	HAML09
◆ Oxford	HAML20
◆ Passion Fruit	HAML02
◆ Pepper	HAML15
◆ Powder	HAML12
◆ Sunrise	HAML01

INERTIA NR

◆ Amethyst	NR61
◆ Calypso	NR98
◆ Cherry	NR66
◆ Cobalt	NR91
◆ Coffee	NR49
◆ Fog	NR19
◆ Fuchsia	NR63
◆ Gecko	NR76
◆ Glow	NR27
◆ Leaf	NR75
◆ Lime	NR82
◆ Loft	NR22
◆ Mandarin	NR47
◆ Meteor	NR30
◆ Mustard	NR26
◆ Nickel	NR23
◆ Onyx	NR10
◆ Regatta	NR90
◆ Shadow	NR20
◆ Surf	NR96
◆ Tangelo	NR46

OPTIC OP

◆ Aurora	OP72
◆ Bark	OP24
◆ Canopy	OP84
◆ Char	OP49
◆ Ruby	OP42
◆ Sand	OP17
◆ Sky	OP83
◆ Slate	OP19
◆ Sprout	OP74
◆ Starry Night	OP11
◆ Storm	OP56
◆ Wildfire	OP66

* Fabric is de-emphasized.

FABRIC PATTERNS & CODES

GRADE 2

APPOINT SEATING	PNS
◆ Blackberry	PNS012
◆ Bronze	PNS002
◆ Carbon	PNS008
◆ Cherry	PNS010
◆ Espresso	PNS003
◆ Framboise	PNS011
◆ Jet	PNS007
◆ Lawn	PNS005
◆ Mandarin	PNS009
◆ Morel	PNS001
◆ Platinum	PNS004
◆ Turquoise	PNS006

BLUME	BLME
◆ Chalk	BLME03
◆ Char	BLME00
◆ Coin	BLME02
◆ Driftwood	BLME05
◆ Emerald City	BLME07
◆ Fir	BLME09
◆ Harvest	BLME04
◆ Haze	BLME08
◆ Hyacinth	BLME14
◆ Jasper	BLME13
◆ Merlot	BLME10
◆ Moonstone	BLME01
◆ Opal	BLME06
◆ Scarlet	BLME11
◆ Slate	BLME12

CLYDE	CLYD
◆ Antique	CLYD04
◆ Artifact	CLYD01
◆ Blacksmith	CLYD10
◆ Claret	CLYD13
◆ Craftsman	CLYD08
◆ Crate	CLYD12
◆ Fossil	CLYD02
◆ Heirloom	CLYD05
◆ Iron	CLYD11
◆ Linen	CLYD14
◆ Relic	CLYD06
◆ Seasoned	CLYD03
◆ Trestle	CLYD07
◆ Weathered	CLYD09

GRADE 2 *continued*

DOTTY	DOT
◆ Candy	DOT63
◆ Gelato	DOT34
◆ Indigo	DOT31
◆ Onyx	DOT35
◆ Park	DOT83
◆ Peat	DOT24
◆ Peony	DOT32
◆ Suit	DOT20
◆ Sunflower	DOT33
◆ Tailor	DOT21
◆ Tide	DOT90
◆ Velum	DOT29
◆ Violet	DOT30

RUSH	RUSH
◆ Anchor	RUSH07
◆ Basil	RUSH16
◆ Blueberry	RUSH10
◆ Flamingo	RUSH21
◆ Greenery	RUSH15
◆ Greyhound	RUSH06
◆ Marina	RUSH13
◆ Merlot	RUSH19
◆ Midnight	RUSH11
◆ Mint	RUSH09
◆ Mulberry	RUSH18
◆ Pumice	RUSH01
◆ Punch	RUSH20
◆ Sage	RUSH14
◆ Salsa	RUSH24
◆ Sand	RUSH05
◆ Seal	RUSH08
◆ Soot	RUSH02
◆ Stout	RUSH03
◆ Sunshine	RUSH23
◆ Tapestry	RUSH04
◆ Tiger	RUSH22
◆ Vintage	RUSH17
◆ Wave	RUSH12

SEED	SED
◆ Apple	SED11
◆ Ash	SED15
◆ Cardinal	SED09
◆ Cinder	SED17
◆ Cream	SED12
◆ Driftwood	SED13
◆ Harbor	SED10
◆ Onyx	SED18
◆ Smoke	SED16
◆ Truffle	SED14

GRADE 2 *continued*

SPIN SEATING	SPNN
◆ Alabaster	SPNN02
◆ Cavern	SPNN03
◆ Cobblestone	SPNN04
◆ Ember	SPNN06
◆ Flame	SPNN07
◆ Heron	SPNN13
◆ Oat	SPNN01
◆ Ocean	SPNN12
◆ Plum	SPNN15
◆ Pool	SPNN11
◆ Raven	SPNN10
◆ Rhubarb	SPNN14
◆ Tropic	SPNN08
◆ Willow	SPNN05

WHISPER VINYL	WP
◆ Antelope	WP20
◆ Black	WP40
◆ Bone	WP17
◆ Bordeaux	WP26
◆ Brick Red	WP99
◆ Camel	WP18
◆ Cappuccino	WP21
◆ Carotene	WP97
◆ Cashew	WP29
◆ Cerulean	WP36
◆ Charcoal	WP39
◆ Cinnamon	WP25
◆ Cognac	WP62
◆ Cucumber	WP88
◆ Elephant	WP38
◆ Espresso	WP49
◆ Fawn	WP91
◆ Fog	WP100
◆ Forest	WP82
◆ Gravel	WP19
◆ Indigo	WP86
◆ Luggage	WP23
◆ Mahogany	WP93
◆ Mallard	WP90
◆ Merlot	WP27
◆ Molten	WP98
◆ Navy	WP37
◆ Ochre	WP96
◆ Paradise	WP85
◆ Patina	WP34
◆ Pewter	WP83
◆ Putty	WP84
◆ Salsa	WP42
◆ Sangre	WP28
◆ Sassafras	WP89
◆ Storm	WP92
◆ Truffle	WP95
◆ Zest	WP87

GRADE 3

IN SEASON	ISN
◆ Black	ISN001
◆ Blue Jay	ISN007
◆ Fire	ISN004
◆ Jungle	ISN008
◆ Lake	ISN006
◆ Lead	ISN002
◆ Limestone	ISN041
◆ Ocean	ISN005
◆ Silver	ISN003
◆ Smoke	ISN020
◆ Tundra	ISN011

PURL	PURL
◆ Alpaca	PURL08
◆ Braid	PURL10
◆ Deep	PURL12
◆ Graze	PURL05
◆ Loom	PURL06
◆ Needle	PURL07
◆ Pasture	PURL02
◆ Ranch	PURL04
◆ Shuttle	PURL09
◆ Skein	PURL01
◆ Thistle	PURL11
◆ Yearling	PURL03

QUILL	QUL
◆ Aviary	QUL03
◆ Feather	QUL02
◆ Fountain	QUL06
◆ Ink	QUL05
◆ Metal	QUL04
◆ Reed	QUL08
◆ Scroll	QUL01
◆ Well	QUL07

FABRIC PATTERNS & CODES

GRADE 3 *continued*

SILVERTEX™ VINYL	SX
◆ Acid	SX34
◆ Basil	SX20
◆ Bazaar	SX37
◆ Blackberry	SX17
◆ Borscht	SX15
◆ Bottle	SX21
◆ Bronze	SX32
◆ Carbon	SX23
◆ Celery	SX19
◆ Champagne	SX08
◆ Chestnut	SX10
◆ Cream	SX07
◆ Crème de Menthe	SX33
◆ Ice	SX06
◆ Imperial	SX38
◆ Jet	SX05
◆ Lagoon	SX02
◆ Limoncello	SX42
◆ Luggage	SX13
◆ Mandarin	SX11
◆ Marine Blue	SX01
◆ Marsh	SX31
◆ Meteor	SX24
◆ Mocha	SX25
◆ Neutra	SX30
◆ Peat	SX35
◆ Plata	SX39
◆ Poppy	SX12
◆ Raspberry	SX16
◆ Sage	SX18
◆ Sapphire	SX04
◆ Sterling	SX40
◆ Storm	SX22
◆ Taupe	SX09
◆ Turquoise	SX03
◆ Umber	SX14
◆ Zest	SX41

For a complete list of fabrics, including partnership fabrics, go to hon.com/fabricsandfinishes.

PANEL FABRIC PATTERNS & CODES

PRICE CODE AA		PRICE CODE A		PRICE CODE A <i>continued</i>		PRICE CODE A <i>continued</i>	
FACTOR	FACT	APPOINT	APN	ETCH*	ECH	REFLECTIONS*	REF
◆ Bark	FACT20	◆ Artichoke	APN11	◆ Axis	ECH13	◆ Galvanized	REF29
◆ Barley	FACT15	◆ Blackberry	APN32	◆ Blend	ECH14	◆ Ice	REF20
◆ Cascade	FACT25	◆ Bronze	APN22	◆ Cast	ECH12	◆ Loggia	REF21
◆ Feather	FACT30	◆ Carbon	APN28	◆ Highlight	ECH10	◆ Mistral	REF28
		◆ Chai	APN12	◆ Midtone	ECH11	◆ Moonstone	REF23
		◆ Cherry	APN30	◆ Outline	ECH08	◆ Pewter	REF22
		◆ Dark Pewter	APN17	◆ Shade	ECH09	◆ Stainless	REF24
		◆ Dune	APN15	◆ Tonal	ECH16	◆ Vanilla	REF25
		◆ Espresso	APN23	◆ Vanish	ECH15	◆ Winter	REF27
		◆ Framboise	APN31				
		◆ Frost	APN34	EXCHANGE*	EXG	REFUGE*	RFG
		◆ Jet	APN27	◆ Iron	EXG916	◆ Artesian	RFG96
		◆ Lawn	APN25	◆ Nickel	EXG914	◆ Dune	RFG92
		◆ Mandarin	APN29	◆ Pistachio	EXG910	◆ Eclipse	RFG90
		◆ Morel	APN09	◆ Root	EXG913	◆ Frost	RFG93
		◆ Nimbus	APN16	◆ Rupee	EXG903	◆ Glacier	RFG91
		◆ Platinum	APN24	◆ Shadow	EXG911	◆ Mineral	RFG98
		◆ Turquoise	APN26	◆ Silver	EXG915	◆ Tidal	RFG94
				◆ Sisal	EXG917		
		CENTURION	CU	◆ Stone	EXG912	SARTO*	SRT
		◆ Apricot	CU47			◆ Ash	SRT88
		◆ Bark	CU25	LANDSCAPE*	LN	◆ Fog	SRT14
		◆ Black	CU10	◆ Azure	LN55	◆ Lemongrass	SRT49
		◆ Espresso	CU49	◆ Cornsilk	LN15	◆ Mist	SRT45
		◆ Fog	CU03	◆ Drift	LN05	◆ Mushroom	SRT76
		◆ Frost	CU22	◆ Khaki	LN20	◆ Oyster	SRT18
		◆ Goldenrod	CU27	◆ Sheen	LN10	◆ Reef	SRT64
		◆ Indigo	CU06	◆ Slate	LN35	◆ Sesame	SRT93
		◆ Iris	CU50	◆ Umber	LN25	◆ Shale	SRT52
		◆ Iron Ore	CU19	◆ Urban	LN30		
		◆ Jade	CU83			TEMPEST*	TP
		◆ Marsala	CU63	LUCY*	LC	◆ Dragonfly	TP30
		◆ Morel	CU24	◆ Aspen	LC32	◆ Frost	TP15
		◆ Navy	CU98	◆ Cornsilk	LC30	◆ Full Stream	TP80
		◆ Peacock	CU97	◆ Dusk	LC22	◆ Gold Rush	TP10
		◆ Pear	CU84	◆ Fawn	LC33	◆ Slate	TP45
		◆ Ruby	CU67	◆ Graphite	LC34	◆ Tumbleweed	TP70
		◆ Sapphire	CU09	◆ Mist	LC20	◆ Wind Chill	TP40
				◆ Neutra	LC24	◆ Zebra	TP35
				◆ Pewter	LC35		
				◆ Snowdrop	LC28		

NOTES: Centurion fabrics not available on panels that exceed a width and height of 54"H.

Exchange is applied pattern cut and is not available on 78"W tackboards, Voi® screens, and Empower®.

Disperse is applied pattern cut and is not available on 72"W Accelerate® panels and not available on 66"W tackboards, Voi® screens, and Empower®.

◆◆◆ For lead time information see page 19.

* Directional fabrics

PANEL FABRIC PATTERNS & CODES

PRICE CODE B

ANALOG	ANLG
◆ Album	ANLG06
◆ Cartridge	ANLG04
◆ Cassette	ANLG09
◆ Dial	ANLG02
◆ Media	ANLG08
◆ Reel	ANLG07
◆ Signal	ANLG03
◆ Stereo	ANLG01
◆ Track	ANLG05

COAST*

COAST*	COA
<i>Not available on Accelerate®</i>	
◆ Channel	COA14
◆ Dune	COA03
◆ Headlands	COA10
◆ Marsh	COA02
◆ Pebble	COA12
◆ Pier	COA13
◆ Shoal	COA01
◆ Silt	COA06
◆ Tide	COA08

PRICE CODE B *continued*

DISPERSE*	DISP
◆ Autumn	DISP03
◆ Branch	DISP10
◆ Coffee Bean	DISP13
◆ Dusk	DISP09
◆ Emerald City	DISP08
◆ Gold Rush	DISP02
◆ Igloo	DISP11
◆ Ink	DISP06
◆ Mist	DISP12
◆ Oatmeal	DISP15
◆ Prince	DISP07
◆ Reservoir	DISP01
◆ Rose	DISP04
◆ Spring	DISP05
◆ Steel	DISP16
◆ Taupe	DISP14

MICA*

MICA*	MCA
◆ Anthracite	MCA11
◆ Breeze	MCA18
◆ Bronze	MCA13
◆ Buff	MCA14
◆ Cremini	MCA17
◆ Crystal	MCAWIT
◆ Dew	MCA20
◆ Dove	MCA12
◆ Fresh	MCA16
◆ Mineral	MCA15
◆ Nectar	MCA19
◆ Shale	MCA10

PRICE CODE B *continued*

SPIN*	SPIN
◆ Alabaster	SPIN02
◆ Cavern	SPIN03
◆ Cobblestone	SPIN04
◆ Ember	SPIN06
◆ Flame	SPIN07
◆ Heron	SPIN13
◆ Oat	SPIN01
◆ Ocean	SPIN12
◆ Plum	SPIN15
◆ Pool	SPIN11
◆ Raven	SPIN10
◆ Rhubarb	SPIN14
◆ Tropic	SPIN08
◆ Willow	SPIN05

TERRAIN*

TERRAIN*	TRRN
◆ Bay	TRRN05
◆ Bayou	TRRN35
◆ Canyon	TRRN30
◆ Cliff	TRRN45
◆ Crest	TRRN25
◆ Delta	TRRN10
◆ Plateau	TRRN15
◆ Ridge	TRRN20
◆ Valley	TRRN40

NOTES: Exchange is applied pattern cut and is not available on 78"W tackboards, Voi® screens, and Empower®.

Disperse is applied pattern cut and is not available on 72"W Accelerate® panels and not available on 66"W tackboards, Voi® screens, and Empower®.

◆◆◆ For lead time information see page 19.

* Directional fabrics

FEATURES OFFERED ON HON LAMINATE CASEGOODS

	10500	10700	Valido	Concinnity	94000	Voi
Worksurfaces						
• Scratch, stain and spill-resistant surface over durable 1/8" solid core high performance particleboard	•	•		•		•
• Scratch, stain and spill-resistant surface over extra-thick 1/2" solid core high performance particleboard			•			
• Scratch, stain and spill-resistant high gloss surface over durable 1/8" solid core high performance particleboard					•	
• Contoured hardwood accent trim		•			•	
• User-friendly waterfall-shaped edges and rounded corners improves worker comfort		•				
• Edge profile options				•		
Chassis Construction						
• European-designed fastening system – Precision, metal-to-metal, fasteners eliminate need for external cleats or exposed screws; enables tops or end panels to be interchanged or replaced	•	•	•	•	•	•
• Inner frame constructed using mortise and tenon joinery for superior structural strength and precisely positioning/securing the pedestal to the modesty panel; endures frequent moving/handling; ensures a longer product life cycle	•	•	•		•	
• All fasteners and dowels are positioned by computer to maintain rigorous dimensional standards	•	•	•	•	•	•
• End panels on base units and stack-ons feature PVC bottom edgebanding for added strength and to seal out moisture	•	•	•	•	•	•
Drawer Construction						
• Steel ball-bearing drawer suspensions for smooth, quiet, long-lasting operation	•	•	•	•	•	•
• 5-sided drawer construction for added strength and easy alignment or replacement of drawer fronts	•	•	•	•	•	•
• Full extension box and file drawers	•	•	•	•	•	•
• Hangrails provided in all file drawers for side-to-side letter, legal, A4 or EDP filing; and front-to-back for letter filing	•	•	•	•	•	•
Amenities						
• Conference overhang (select models) provides visitor's kneespace on approach side of desk for meetings	•	•	•	•	•	•
• Formal, full height modesty panels	•	•	•	•	•	•
• Short modesty panel option for easy access to wall electrical outlets	•	•	•	•		
• Patented, side-mounted drawer handles provide good ergonomics and clean appearance	•	•				
• Antique brass drawer handles					•	
• Decorative drawer/door handle design and finish options			•	•		•
• Vertical grain direction on drawer fronts and modesty panels				•	•	•
• Upscale mixed material door options (select models) on overhead storage	•	•	•	•	•	•
• Adjustable hex leveling glides to level furniture without lifting	•	•	•	•	•	•
• Pullout reference/writing shelf provides additional worksurface space					•	
• Interchangeable lock cores (allow multiple units to be keyed alike)	•	•	•	•	•	•
• Central locking on desks (one lock secures all drawers)					•	
• Cord management (standard) to route and hide wires and cables	•	•	•	•	•	
• Cord management options on modular components (worksurfaces, end and modesty panels, pedestals)				•		•
Configuration Options						
• Components for efficient "U" and "L" shaped workstation layouts	•	•	•	•	•	•
• Peninsulas and corner units	•	•	•	•		
• Worksurfaces or shells up to 96"W	•			•		
• Standing, 42"H desking solutions	•			•		•
• Overheads sized to span multiple base units	•	•	•	•	•	•
• Reception station/transaction counter	•	•	•	•	•	
• Light scale styling, including worksurface components with O-leg supports	•			•		•
• Two-tone color options	•		•	•		•
Storage Options						
• 3/4 pedestals provide increased budget flexibility	•	•	•			
• Full desktop-to-floor pedestals maximize storage space	•	•	•	•	•	•
• Modular components/storage with precise, custom cabinet-like fits				•		•
• Modular shells w/ a variety of storage-pedestal solutions	•	•	•			
• Back wall storage in conventional (65") and executive (78") heights				•		
• Overheads, storage cabinets, wardrobes, lateral files, and bookcases	•	•	•	•	•	•
Companion Products						
• Matching conference tables	•			•	•	•
• Coordinating conference tables		•	•			
Endorsements						
• Meets or exceeds current ANSI/BIFMA and ISTA standards	•	•	•	•	•	•
• Meets SCS Indoor Advantage Certification (see page 17)	•	•	•	•	•	•
• level® certified in conformance with the BIFMA e3 furniture sustainability standard	•	•	•	•	•	•

CONCINNITY™



Concinnity™ Executive Workstation shown with Ignition® and Grove® Seating and Flock® Tables.

CONCINNITY™

Clean styling. Rich woodgrains. Mixed materials. A coordinated suite of components. With Concinnity, you can create an upscale look for all types of office spaces — from open to collaborative to private. Choose from a variety of desk configurations and an extensive selection of storage options to create the ideal solution to fit your footprint and your needs.



FEATURES

- Cohesive visual signature highlighted by clean lines, vertical grain, and components that fit together like custom cabinetry.
- Modular design delivers an unbeatable combination of versatility, style, and personalization to any workspace.
- Wide array of aesthetic options, including edge profiles, handles, mixed materials, and laminate finish combinations.
- Extensive assortment of storage solutions allow users to increase functionality, maximize space and keep everything conveniently within reach.
- Products to create flat, continuous horizontal planes or multi-level, overlapping, layered surfaces.
- Standing-height workstations to support today's healthy work styles; available with adjustable or fixed height bases.

CONCINNITY™ ORDERING INFORMATION

WORKSURFACES

L1 LAMINATES CODES

Woodgrain

- ◆ Bourbon Cherry H
- ◆ Cognac COGN
- ◆ Florence Walnut LFW1
- ◆ Harvest C
- ◆ Kingswood Walnut LK11
- ◆ Mahogany N
- ◆ Mocha MOCH
- ◆ Natural Maple D
- ◆ Pinnacle PINC
- ◆ Shaker Cherry F
- ◆ Sterling Ash LSA1

Solid

- ◆ Black P
- ◆ Charcoal S
- ◆ Designer White LDW1
- ◆ Loft LOFT

Patterned

- ◆ Sheer Mesh A5
- ◆ Silver Mesh B9

L2 LAMINATES CODES

Woodgrain

- ◆ Lowell Ash LLA1
- ◆ Natural Recon LNR1
- ◆ Phantom Ecru LPE1
- ◆ Portico Teak LPT1
- ◆ Skyline Walnut LSW1

DRAWER AND DOOR FRONTS

L1 LAMINATES CODES

Woodgrain

- ◆ Bourbon Cherry H
- ◆ Cognac COGN
- ◆ Florence Walnut LFW1
- ◆ Harvest C
- ◆ Kingswood Walnut LK11
- ◆ Mahogany N
- ◆ Mocha MOCH
- ◆ Natural Maple D
- ◆ Pinnacle PINC
- ◆ Shaker Cherry F
- ◆ Sterling Ash LSA1

Solid

- ◆ Black P
- ◆ Charcoal S
- ◆ Designer White LDW1
- ◆ Loft LOFT

Patterned

- ◆ Sheer Mesh A5
- ◆ Silver Mesh B9

L2 LAMINATES CODES

Woodgrain

- ◆ Lowell Ash LLA1
- ◆ Natural Recon LNR1
- ◆ Phantom Ecru LPE1
- ◆ Portico Teak LPT1
- ◆ Skyline Walnut LSW1

HANDLE/LOCK

FINISHES CODES

P1

- ◆ Black P
- ◆ Satin SA

CHASSIS, END, MODESTY, AND BACK PANELS

L1 LAMINATES CODES

Woodgrain

- ◆ Bourbon Cherry H
- ◆ Cognac COGN
- ◆ Florence Walnut LFW1
- ◆ Harvest C
- ◆ Kingswood Walnut LK11
- ◆ Mahogany N
- ◆ Mocha MOCH
- ◆ Natural Maple D
- ◆ Pinnacle PINC
- ◆ Shaker Cherry F
- ◆ Sterling Ash LSA1

Solid

- ◆ Black P
- ◆ Charcoal S
- ◆ Designer White LDW1
- ◆ Loft LOFT

L2 LAMINATES CODES

Woodgrain

- ◆ Lowell Ash LLA1
- ◆ Natural Recon LNR1
- ◆ Phantom Ecru LPE1
- ◆ Portico Teak LPT1
- ◆ Skyline Walnut LSW1

HMBPOST AND HMBTLEG24

PAINTS CODES

P1

- ◆ Black P

P2

- ◆ Platinum Metallic T1

SILVER COLORWAY: The following finish options are coordinating silver colorways — Satin, Satin Nickel, Matte Chrome, Platinum, and Platinum Metallic.

EDGE PROFILES “B” AND “V”

EDGEBAND COLORS CODES

Woodgrain

- ◆ Bourbon Cherry H
- ◆ Cognac COGN
- ◆ Florence Walnut FW
- ◆ Harvest C
- ◆ Kingswood Walnut LK11
- ◆ Mahogany N
- ◆ Mocha MOCH
- ◆ Natural Maple D
- ◆ Pinnacle PINC
- ◆ Shaker Cherry F
- ◆ Sterling Ash SA

EDGE PROFILE “G”

EDGEBAND COLORS CODES

Woodgrain

- ◆ Bourbon Cherry H
- ◆ Cognac COGN
- ◆ Florence Walnut FW
- ◆ Harvest C
- ◆ Kingswood Walnut KI
- ◆ Lowell Ash DL
- ◆ Mahogany N
- ◆ Mocha MOCH
- ◆ Natural Maple D
- ◆ Natural Recon NR
- ◆ Phantom Ecru PE
- ◆ Pinnacle PINC
- ◆ Portico Teak DP
- ◆ Shaker Cherry F
- ◆ Skyline Walnut SW
- ◆ Sterling Ash SA

Solid

- ◆ Black P
- ◆ Charcoal S
- ◆ Designer White DW
- ◆ Loft LOFT

Pattern laminates do not have a matching edgeband color; they are available with a woodgrain or solid color edge.

◆◆◆ For lead time information see page 19.

CONCINNITY™ ORDERING SPECIFICATION/MODEL LOGIC

DESKS	
Double Pedestal Desk	Model Edge Profile + Edge Color Handle Worksurface Grommet Finish Worksurface Color Chassis Color Drawer Front Color
Single Pedestal Desk (Left & Right)	Model Edge Profile + Edge Color Handle Worksurface Grommet Finish Worksurface Color Chassis Color Drawer Front Color
CREDENZAS	
Credenza w/ Storage	Model Edge Profile + Edge Color Handle Worksurface Grommet Finish Worksurface Color Chassis Color Drawer/Door Front Color
Credenza w/ Kneespace	Model Edge Profile + Edge Color Handle Worksurface Grommet Finish Worksurface Color Chassis Color Drawer Front Color
Credenza w/ Lateral File (Left & Right)	Model Edge Profile + Edge Color Handle Worksurface Grommet Finish Worksurface Color Chassis Color Drawer Front Color
Single Pedestal Credenza (Left & Right)	Model Edge Profile + Edge Color Handle Worksurface Grommet Finish Worksurface Color Chassis Color Drawer Front Color
Credenzas - Low/Bench-Height	Model Edge Profile + Edge Color Handle Top Color Chassis Color Drawer Front Color
RETURNS	
Return (Left & Right)	Model Edge Profile + Edge Color Handle Worksurface Grommet Finish Worksurface Color Chassis Color Drawer Front Color
BULLET PENINSULA	
Bullet Peninsula	Model Edge Profile + Edge Color Worksurface Color Chassis Color
BRIDGES	
Bridge	Model Edge Profile + Edge Color Worksurface Grommet Finish Worksurface Color Chassis Color
CORNER UNITS	
Corner Unit	Model Edge Profile + Edge Color Worksurface Grommet Finish Worksurface Color Chassis Color
JETTY PENINSULAS	
Jetty Peninsula	Model Edge Profile + Edge Color Worksurface Grommet Finish Worksurface Color Chassis Color
STACK-ON STORAGE	
Stack-On Storage w/ Laminate Doors	Model Chassis Color Door Front Color
Stack-On Storage w/ Laminate Locking Doors	Model Lock Finish Chassis Color Door Front Color
Stack-On Storage w/ Frosted Doors	Model Chassis Color
Stack-On Storage w/ Sliding Door	Model Chassis Color Door Front Color
Stack-On Space Saver End Panels	Model Laminate Color
WALL MOUNTED STORAGE	
Wall Mounted Storage w/ Laminate Doors	Model Chassis Color Door Front Color
Wall Mounted Storage w/ Laminate Locking Doors	Model Lock Finish Chassis Color Door Front Color
Wall Mounted Storage w/ Frosted Doors	Model Chassis Color
Wall Mounted Storage w/ Sliding Door	Model Chassis Color Door Front Color
BOOKCASE HUTCHES	
Bookcase Hutch - No Doors/Open	Model Laminate Color
Bookcase Hutch w/ Laminate Doors	Model Handle Chassis Color Door Front Color
Bookcase Hutch w/ Frosted Doors	Model Laminate Color
RECEPTION STATIONS	
Reception Station	Model Edge Profile Edge Color Counter Color Chassis Color
Reception Station Counter	Model Edge Profile + Edge Color Counter Color Chassis Color
L-Reception Station Counter	Model Edge Profile + Edge Color Counter Color Chassis Color
Reception Desk with Transaction Counter	Model Edge Profile + Edge Color Worksurface Grommet Color Worksurface Color Chassis Color Accent Color
Reception Return with Transaction Counter	Model Edge Profile + Edge Color Worksurface Color Chassis Color
L-Reception Station with Transaction Counter	Model Edge Profile + Edge Color Counter Color Chassis Color
Transaction Counter Organizer	Model Edge Profile + Edge Color Counter Color Chassis Color
LATERAL FILES & STORAGE CABINETS	
Lateral File	Model Edge Profile + Edge Color Handle Top Color Chassis Color Drawer Front Color
Storage Cabinet - 78 $\frac{1}{8}$ " and 64 $\frac{3}{4}$ "H	Model Handle Chassis Color Door Front Color
Storage Cabinet - 29 $\frac{1}{2}$ "H	Model Edge Profile + Edge Color Handle Top Color Chassis Color Door Front Color
Storage/File Cabinet - No Doors/Open	Model Handle Chassis Color Drawer Front Color
Storage/File Cabinet w/ Laminate Door	Model Handle Chassis Color Door & Drawer Front Color
Storage Cabinet/Lateral File	Model Handle Chassis Color Door & Drawer Front Color

CONCINNITY™ ORDERING SPECIFICATION/MODEL LOGIC

WARDROBES	
Wardrobe/Storage Cabinet	Model Handle Chassis Color Door Front Color
Wardrobe/Bookcase	Model Handle Chassis Color Door Front Color
STORAGE TOWERS	
24"W Storage Tower	Model Handle Chassis Color Door & Drawer Front Color
18"W Storage Tower	Model Handle Chassis Color Door Front Color
BOOKCASES	
Bookcase	Model Edge Profile and Edge Color Top Color Chassis Color
Bookcase w/ Coat Hooks	Model Laminate Color
WORKSURFACES	
Rectangle Worksurface	Model Edge Profile + Edge Color Grommet Worksurface Color
Bow Worksurface	Model Edge Profile + Edge Color Grommet Worksurface Color
Bullet Worksurface	Model Edge Profile + Edge Color Grommet Worksurface Color
Extended Corner Worksurface	Model Edge Profile + Edge Color Worksurface Grommet Worksurface Color End Panel Color
PANELS & LEGS	
27 ¹ / ₈ "H Modesty/Back Panel	Model Grommet Laminate Color
10"H Modesty/Back Panel	Model Laminate Color
10"H Modesty Panel for Desks with O-Legs	Model Laminate Color
14"H Floating Modesty Panel	Model Laminate Color or Mixed Material
Half-Height Modesty Panel	Model Laminate Color
Full-Height Modesty Panel	Model Laminate Color
Full Back Panel for Pedestals - 30" & 36"W x 27 ¹ / ₈ "H	Model Grommet Laminate Color
Full Back Panel for Pedestals - 9 ¹ / ₂ ", 15 ³ / ₄ ", & 18"W	Model Laminate Color
Full Back Panel for Pedestals - 9 ¹ / ₂ " & 15 ³ / ₄ "W x 40 ³ / ₈ "H	Model Laminate Color
Low Back Panel for Pedestal	Model Laminate Color
Laminate End Panel - 1 ¹ / ₈ "W x 28 ¹ / ₂ " or 41"H	Model Grommet Laminate Color
Laminate End Panel - 1 ¹ / ₈ "W x 7"H	Model Laminate Color
Laminate End Panel - L-Shape	Model Grommet Laminate Color
Laminate End Panel - T-Shape	Model Laminate Color
Laminate End Panel - Kneespace Clearance	Model Laminate Color
Laminate End Panel - Support Brace	Model Laminate Color
Metal O-Leg	Model Paint Color
PEDESTALS	
Pedestal - Narrow Box/Box/File	Model Handle Grommet Chassis Color Drawer Front Color
Pedestal - Narrow File/File	Model Handle Grommet Chassis Color Drawer Front Color
Pedestal - Box/Box/File	Model Handle Grommet Chassis Color Drawer Front Color
Pedestal - File/File	Model Handle Grommet Chassis Color Drawer Front Color
Pedestal - Lateral File	Model Handle Grommet Chassis Color Drawer Front Color
Pedestal - Shelf/Box/Box/Lateral File	Model Handle Grommet Chassis Color Drawer Front Color
Pedestal - Storage Cabinet	Model Handle Grommet Chassis Color Door Front Color
Pedestal - Bookcase	Model Grommet Chassis Color
Pedestal - Bookcase End Support	Model Chassis Color
Mobile Pedestal - Box/Box/File, File/File, Box/File	Model Handle Chassis Color Drawer Front Color
Mobile Pedestal - 30"W Shelf/File/Cabinet	Model Edge Profile + Edge Color Handle Top Color Chassis Color Drawer/Door Front Color
Pedestal Tops	Model Edge Profile + Edge Color Top Color
Pedestal - Box/Box/File/File	Model Handle Grommet Chassis Color Drawer Front Color
Pedestal - Shelf/Box/Box/File	Model Handle Grommet Chassis Color Drawer Front Color
Pedestal - Narrow Box/Box/File/File	Model Handle Grommet Chassis Color Drawer Front Color
ACCESSORIES	
Laminate Center Drawer	Model Laminate Color
Collaborative Desk Shelf	Model Laminate Color
Wall Mount	Model
Wall Mount	Model Fabric
Field Installable Grommet	Model
Lock Core Kit	Model

CONCINNITY™ LAMINATE DESIGN/MATERIALS INFORMATION

STYLING AND CONSTRUCTION

- Conventional desking or light scale components.
- Clean, uninterrupted lines and precise fits; no gaps.
- All end, modesty, and back panels, as well as drawer and door fronts, that are specified in a woodgrain color, feature vertical grain; drawer fronts are vertically-aligned, continuous grain and are matched sets.
- All desk, credenza, and return models feature full-to-the-floor pedestals to maximize storage space.
- Factory-configured (i.e., built-up; assembled) 72"W desks can be specified with breakfront or recessed modesty panels.
- Formal, full height modesty panels on factory-configured (i.e., built-up; assembled) desks, credenzas, and returns; modular components available with full or 10" modesty panels.
- Drawer and door fronts over end panels.
- Back panel-over-end panel on desks, credenzas, returns, mobile pedestals, 29½"H lateral files and storage cabinets, and full-length modesty panels for modular pedestals.
- Top-between-end panels on stack-on and wall mount storage, 66⅝"H & 79½"H storage and combination storage cabinets, wardrobes and towers.
- Option choices include:
 - Edge profile and edge color
 - Handle design
 - Handle/worksurface grommet/lock face finish
 - Worksurface color
 - Chassis color
 - Drawer front/door color
- **IMPORTANT NOTE:** Designed and sized to coordinate with 65"H Accelerate® Panels.
 - Desks, credenzas, returns, 2-drawer lateral files, and 29½"H storage cabinets, plus 35¼"H stack-on storage or bookcase hutch, are 64¾"H.
 - Additional solutions ≤65"H include the following: storage cabinet, storage/file cabinet, storage cabinet/lateral file, 18" and 36"W wardrobe/storage cabinets, wardrobe/bookcase, storage tower, and 5-shelf bookcase.

MATERIALS

- Easy-care, scratch-, spill- and stain-resistant thermal-fused laminate (TFL) over solid core, high performance particleboard;
 - Component model thickness: 1⅛" worksurfaces and end panels; ¾" modesty panel and drawer/door fronts.
- Durable, impact-resistant banding protects edges.

- Bottom of end panels on base units and stack-ons feature edgebanding for added strength and to seal out moisture.
- HPL worksurfaces are available via special request.

DRAWER SPECIFICATIONS

- Operate on steel ball-bearing slides to ensure smooth, quiet, long-lasting operation.
- Full extension drawers allow complete access to contents.
- Drawers feature 5-sided construction for added strength and easy alignment or replacement of drawer fronts.
- File drawers include integrated hangrails for side-to-side letter or legal filing; and front-to-back for letter filing.
- One molded black pencil tray is included in each box/box/file pedestal.
- Drawer fronts are edgebanded on all four sides.

CORE REMOVABLE LOCKS

- All drawers/doors lock on the following products:
 - All desk, credenza, and return pedestals (NOTE: The lock is on the face of the pedestal)
 - Stack-on and wall mount storage with laminate locking doors ("LL" models)
 - Wall mount storage with sliding door
 - Mobile pedestals
 - Lateral files
 - Storage cabinets
 - Storage/file cabinet
 - Storage cabinet/lateral file
 - Wardrobe/storage cabinets
 - Storage towers
 - Modular pedestals
- On products that are equipped with two locks, the locks are keyed alike:
 - Double pedestal desks
 - Credenza with storage
 - Credenzas with kneespace
 - Low credenzas with four drawers
 - Storage and combination storage/file cabinets
 - Storage towers
 - Stack-on and wall mount storage 60" - 78"W
- Lock faces are available in black or satin.

CONCINNITY™ LAMINATE DESIGN/MATERIALS INFORMATION

- Locks feature a removable cylinder (core) that can be interchanged as needed; allows all furniture pieces within an individual workstation to be accessed with one key for convenience, and allows locks to be differentiated between workstations and offices for security. Makes re-keying quick and easy.
 - Keyed alike cores must be ordered separately by specification of the key number. For all products, except stack-on and wall mounted storage, the removable lock core kits are HF23B for Black and HF23S for Satin (Silver).
 - EXCEPTION - IMPORTANT - NOTE: The removable lock core kit for stack-on and wall mounted storage is model HF27B (Black) or HF27S (Satin).

CORD MANAGEMENT

- Cord management grommets and pass-through cutouts, for routing and hiding wires and cables, are standard in a pre-determined location on a number of factory-configured (i.e., built-up; assembled) products:
 - Two grommets are located in the tops of desks and credenzas; one grommet is located in the top of returns, bridges, jetty peninsulas, and corner units.
 - All desk, credenza, and return pedestals are designed with two cord pass-through grommets, one per side; end panels of single pedestal desks and single pedestal credenzas feature one cord pass-through grommet.
 - Pass-through in the sides of pedestals and end panels enable the routing of cords below the worksurface and connections between workstations.
 - A pass-through grommet, to facilitate reaching wall electrical outlets, is located in the back panels of credenza with storage, credenza with kneespace, single pedestal credenzas, credenzas with 36" lateral file, returns and bridges.
- See chart on page 36 for cord management options. Worksurfaces/tops, end and modesty panels, and pedestals can be specified with or without grommets.
- Grommets on worksurfaces are sized to accept optional grommet mount power hub (HGRMTAC) and USB (HGRMTUSB2) models.

- Grommet color/shape/size:
 - Worksurfaces, Black or Platinum, Round, 3" diameter hole with a 3½" plastic cap.
 - Back/modesty panels, Black, Round, 2½" diameter hole with a 3" plastic cap.
 - End panels and pedestal sides, Black, Half-round, 1¾" diameter hole with a 2" x 2½" plastic cap.

LEVELING GLIDES

- Adjustable hex glides to compensate for uneven floors; allow furniture to be easily leveled without lifting the unit.
 - Glides have a 1¼" adjustable range.
 - The hex adjustment is on the foot of the glide for all products except for the 9½", 15¾", and 18"W modular pedestals, in which case it is on the top of the glide stem.

IMPORTANT — OTHER







- Products ship fully assembled, unless otherwise noted (NOTE:  — easy-to-assemble — items are designated in the "DESCRIPTIONS").
- All models must meet or exceed ANSI/BIFMA & ISTA performance standards.
- Products covered by HON Limited Lifetime Warranty.
- Indoor Advantage™ Gold. Indoor Air Quality Certified to SCS-EC10.3-2014 v3.0.
- BIFMA level® 2 certified. Conforms to ANSI/BIFMA e32014e Furniture Sustainability Standard.

CONCINNITY™

LAMINATE ORDERING/SPECIFICATION INFORMATION

WORKSURFACE/TOP EDGE DETAILS

- Three options; two contoured profiles and one smooth, flat edge.
- For beaded (B) and tri-oval (V) edge shapes, tops are profiled on the user and approach sides, and flat on the ends; the flat edges allow side-by-side placement of worksurfaces without gaps. The only exceptions are return, bridge, corner unit, extended corner worksurface, and rectangle worksurface with vertical grain models, tops on these items are profiled on the user's side and flat banded on the approach side and ends.
 - Bookcases have profiled edge on the front, user side only.
 - The reception station transaction counter and the L-reception station with transaction counter (for the desk) models, have profiled edgeband on the approach and user sides.
 - The L-reception station with the transaction counter models, on which the counter runs around the entire perimeter of the L-configuration, have a profiled edge on the front of the transaction counter on the desk approach side only.

Edge Options:	Profiles	Designator
Beaded		 B
Smooth, Flat		 G
Tri-Oval		 V

WORKSURFACE EDGE COLORS

- Woodgrain and solid color laminates can be specified with a matching, complementary, or contrasting edgeband color; options include:
 - Matching the worksurface edge to a common worksurface, chassis, and drawer front color.
 - Matching the worksurface edge to the worksurface laminate and selecting a different laminate color for the chassis.
 - Matching the worksurface edge to the chassis laminate and selecting a different laminate color for the worksurface.

- Beaded (B) and tri-oval (V) edges are available in L1 woodgrain colors only.
- The smooth, flat (G) edge is available in woodgrain and solid colors.
- Pattern laminates do not have a matching edgeband color; the patterns are available with a woodgrain or solid color edge.

DRAWER/DOOR DECORATIVE HANDLES

- Three handle style options, each available in Satin or Black finish.
- Distinct, easy to grasp designs.
- Handles are metal.
- The hole spacing is 128mm.
- The handle style/finish has to be specified on drawer fronts (desk/credenza/return, mobile and modular pedestals), lateral file drawer fronts, the doors of the storage cabinet, storage/file cabinet, storage cabinet/lateral file, wardrobe/storage cabinet, wardrobe/bookcase, and storage tower.
 - NOTE: Decorative handles are not used on the doors of stack-on storage units or wall mounted storage cabinets.
 - Bookcase hatches with frosted doors are equipped with a push latch release.

Handle Options	Finish	Designator
Cylinder	Satin	A
Cylinder	Black	B
Canopy	Satin	C
Canopy	Black	D
Loop	Satin	E
Loop	Black	F

- NOTE: The Linear and Arch field installable drawer/door handle kit models can be attached using 128mm hole spacing.

LAMINATE ORDERING/SPECIFICATION INFORMATION

CORD MANAGEMENT GROMMETS

- Grommets are standard on desk, credenza, return, bridge, jetty peninsula, and corner unit models. Specification logic includes the grommet finish for tops; choose from Black (P) or Platinum (T1). Grommets in modesty and end panels are Black only.
- Grommets are optional on modular component worksurfaces, full-length (27⁷/₈"H) modesty panels, end panels (1¹/₈", L-shaped) and the sides of support storage pedestals. On worksurfaces, choose from Black (P), Platinum (T1), or no grommet(s) (X). On modesty, end, and side panels the options are grommet Black (P) or no grommet (X).
- See cord management chart on page 36 for details.

LOCK FINISH

- Finish is determined by, and automatically aligned with, the handle finish specified. If there is no decorative handle on the product, such as on locking stack-on or wall mount storage models, the lock finish is specified separately in the option string.
 - When specification is required, the lock finish options are Black (P) or Satin (SA).
- Removable, interchangeable lock core kits must be ordered separately:
 - For all models, except stack-on and wall mount storage, specify model HF23B (Black) or HF23S (Satin), and the specific key number required.
 - For stack-on and wall mount storage, specify model HF27B (Black) or HF27S (Satin), and the specific key number required.

SILVER COLORWAY

- The following finish options are coordinating Silver colorways: Satin, Satin Nickel, Matte Chrome, Platinum, and Platinum Metallic.

LAMINATE COLORS

- Palette choices include eight (15) woodgrain, four (4) solid, and two (2) pattern colors.

Woodgrain		Solid Color		Pattern	
Bourbon Cherry	H	Black	P	Sheer Mesh	A5
Cognac	COGN	Charcoal	S	Silver Mesh	B9
Florence Walnut	LFW1	Designer White	LDW1		
Harvest	C	Loft	LOFT		
Kingswood Walnut	LK11				
Lowell Ash	LLA1				
Mahogany	N				
Mocha	MOCH				
Natural Maple	D				
Natural Recon	LNR1				
Phantom Ecru	LPE1				
Pinnacle	PINC				
Portico Teak	LPT1				
Shaker Cherry	F				
Skyline Walnut	LSW1				
Sterling Ash	LSA1				

- Worksurface, chassis and drawer/door fronts are specified separately to enable a single, color-matched visual, or a complementary or contrasting, multi-tone aesthetic.
- Worksurfaces/tops are available in woodgrain, solid, or pattern laminate colors.
- Chassis and drawer fronts are available in woodgrain or solid laminate colors.
- Pattern colors are available on worksurface tops only.

Worksurface		Chassis		Drawer/Door	
Bourbon Cherry	H	Bourbon Cherry	H	Bourbon Cherry	H
Cognac	COGN	Cognac	COGN	Cognac	COGN
Florence Walnut	LFW1	Florence Walnut	LFW1	Florence Walnut	LFW1
Harvest	C	Harvest	C	Harvest	C
Kingswood Walnut	LK11	Kingswood Walnut	LK11	Kingswood Walnut	LK11
Lowell Ash	LLA1	Lowell Ash	LLA1	Lowell Ash	LLA1
Mahogany	N	Mahogany	N	Mahogany	N
Mocha	MOCH	Mocha	MOCH	Mocha	MOCH
Natural Maple	D	Natural Maple	D	Natural Maple	D
Natural Recon	LNR1	Natural Recon	LNR1	Natural Recon	LNR1
Phantom Ecru	LPE1	Phantom Ecru	LPE1	Phantom Ecru	LPE1
Pinnacle	PINC	Pinnacle	PINC	Pinnacle	PINC
Portico Teak	LPT1	Portico Teak	LPT1	Portico Teak	LPT1
Shaker Cherry	F	Shaker Cherry	F	Shaker Cherry	F
Skyline Walnut	LSW1	Skyline Walnut	LSW1	Skyline Walnut	LSW1
Sterling Ash	LSA1	Sterling Ash	LSA1	Sterling Ash	LSA1
Black	P	Black	P	Black	P
Charcoal	S	Charcoal	S	Charcoal	S
Designer White	LDW1	Designer White	LDW1	Designer White	LDW1
Loft	LOFT	Loft	LOFT	Loft	LOFT
Sheer Mesh	A5				
Silver Mesh	B9				

- Two-tone color options allow specification of different, complementary laminate combinations:

Color #1	Color #2
Top	Chassis and Drawer Fronts
Top and Drawer Fronts	Chassis
Top and Chassis	Drawer Fronts

- Modesty panels and the backs of storage chassis that are specified in L2 laminates and wider than 60"W will ship as horizontal grain.

CONCINNITY™ CORD MANAGEMENT

	GROMMET	# OF GROMMETS	LOCATION	CUTOUT SHAPE	MATERIAL	COLOR/FINISH
BUILT-UP/FACTORY-CONFIGURED						
DESK						
Top	Standard/Fixed Location	2	Back Left & Right	3" Round	Plastic	Black or Platinum
End Panel	Standard/Fixed Location	2 (1 per EP)	Top Back Corner	1¼" Round	Plastic	Black
Modesty/Back	Not Available	0	N/A	N/A	N/A	N/A
CREDENZA						
Top	Standard/Fixed Location	2	Back Left & Right	3" Round	Plastic	Black or Platinum
End Panel	Standard/Fixed Location	2 (1 per EP)	Top Back Corner	1¼" Round	Plastic	Black
Modesty/Back	Standard/Fixed Location	1	Top Center	2½" Round	Plastic	Black
RETURN						
Top	Standard/Fixed Location	1	Top Center	3" Round	Plastic	Black or Platinum
End Panel	Standard/Fixed Location	1	Top Back Corner	1¼" Round	Plastic	Black
Modesty/Back	Standard/Fixed Location	1	Top Center	2½" Round	Plastic	Black
BRIDGE						
Top	Standard/Fixed Location	1	Back Center	3" Round	Plastic	Black or Platinum
Modesty/Back	Standard/Fixed Location	1	Top Center	2½" Round	Plastic	Black
BULLET PENINSULA						
Top	Not Available	0				
End Panel	Not Available; Pass-Thru in Brace Panel	0				
JETTY PENINSULA						
Top	Standard/Fixed Location	1	Back, Approach-Side Corner	3" Round	Plastic	Black or Platinum
End Panel	Not Available; Pass-Thru Standard in Brace Panel	0				
CORNER UNIT						
Top	Standard/Fixed Location	1	Back Corner	3" Round	Plastic	Black or Platinum
Modesty/Back	Not Available; Pass-Thru Standard in Brace Panels	0				
Stack-on	Standard/Fixed Location	1	1¼" Side-to-Side Gap at Top or Bottom of Back Panel, Below Cabinet			
MODULAR COMPONENTS – WORKSURFACES						
Rectangle – 60" to 96"W	Optional – Specify: Black (P) or Platinum (T1) or None (X)	2	Back Left & Right	3" Round	Plastic	Black or Platinum
Rectangle – 30" to 54"W	Optional – Specify: Black (P) or Platinum (T1) or None (X)	1	Back Center	3" Round	Plastic	Black or Platinum
Bullet Shape	Optional – Specify: Black (P) or Platinum (T1) or None (X)	1	Centered Along EP; Over Brace Leg Cutout	3" Round	Plastic	Black or Platinum
Ext. Corner	Optional – Specify: Black (P) or Platinum (T1) or None (X)	1	Back Corner of Top and Long End Panel	3" Round	Plastic	Black or Platinum
MODULAR COMPONENTS – MODESTY PANELS						
Full-Length – ≥30"W	Optional – Specify: Black (P) or None (X)	1	Top Center	2½" Round	Plastic	Black
10"	No	0				
MODULAR COMPONENTS – END PANELS						
1½" Thick	Optional – Specify: Black (P) or None (X)	1	Top Back Corner	1¼" Round	Plastic	Black
T-Shaped	No	0				
L-Shaped	Optional – Specify: Black (P) or None (X)	1	Top or Bottom Centered	1¼" Round	Plastic	Black
MODULAR COMPONENTS – STORAGE PEDESTALS						
Pedestal	Optional – Specify: Black (P) or None (X)	2 (1 per EP)	Top Back Corner	1¼" Round	Plastic	Black

NOTE: If customer wants a desk, credenza, return, or bridge without grommets, they can specify modular components.

Grommet Locations in Tops

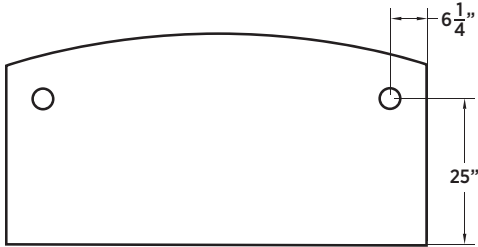

Bow Top Desks and Worksurfaces

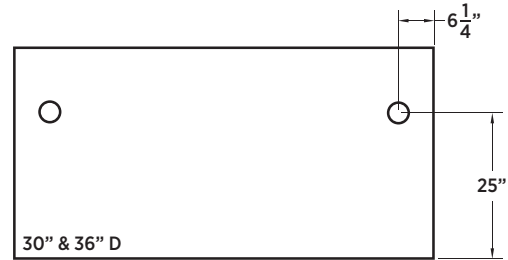

Desks and Rectangle Worksurfaces

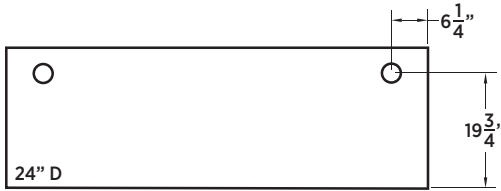

Credenzas and Rectangle Worksurfaces

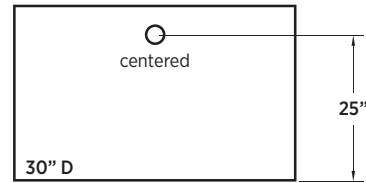

Rectangle Worksurfaces

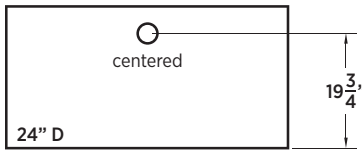

Returns, Bridges, and Rectangle Worksurfaces

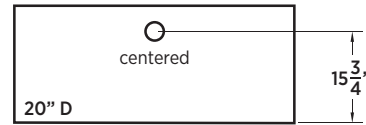

Rectangle Worksurfaces

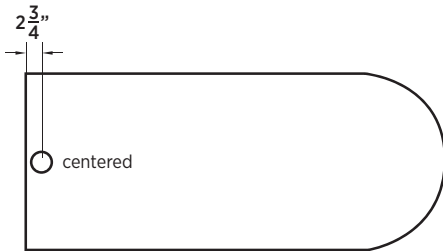

Bullet Worksurfaces

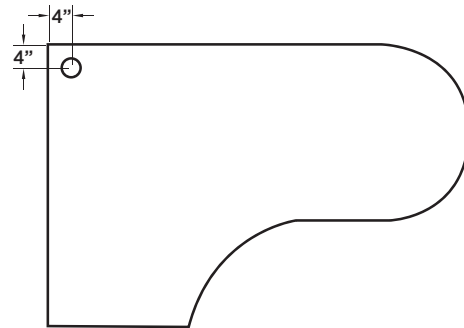

Jetty Peninsula

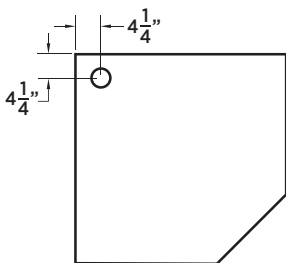

Corner Unit

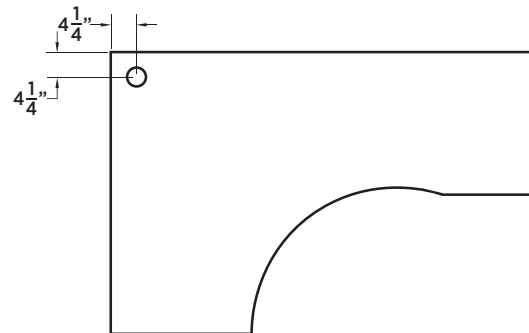

Extended Corner Worksurfaces

CONCINNITY™

Typicals



Icon Legend on page 19

QTY	DESCRIPTION	MODEL	LIST PRICE	PRICE EXTENSION
1	Double Pedestal Desk, Bow Top, Breakfront Frosted Modesty Panel 72"W x 36"D x 29½"H	HNL3672DPBBF	\$2,883	\$2,883
1	Credenza with Kneespace 72"W x 24"D x 29½"H	HNL2472DPK	\$1,818	\$1,818
1	Wall Mount Storage, Frosted Doors with Silver Frame 72"W x 15"D x 28½"H	HNL2972FD	\$2,361	\$2,361
1	Storage/File Cabinet, Hinged Right 18"W x 24"D x 64¾"H	HNL241865SFLR	\$1,740	\$1,740
1	Storage/File Cabinet, Hinged Left 18"W x 24"D x 64¾"H	HNL241865SFL	\$1,740	\$1,740
TOTAL:			\$10,542	

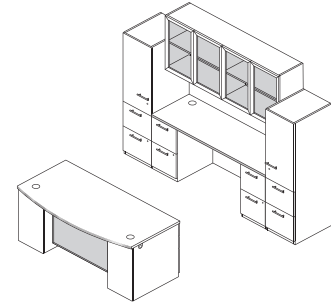
**DESK — CREDENZA — STORAGE**

QTY	DESCRIPTION	MODEL	LIST PRICE	PRICE EXTENSION
1	Left Pedestal Desk, Rectangle Top, Breakfront Modesty Panel 72"W x 36"D x 29½"H	HNL3672LPRB	\$1,911	\$1,911
1	Rectangle Worksurface with Vertical Grain 42"W x 24"D	HNLRC2442V	\$256	\$256
1	Narrow File/File Pedestal 9½"W x 23⅞"D x 28½"H	HNL231028PFF	\$690	\$690
1	Modesty/Back Panel — Full-Length 42"W x 27⅞"H	HNLMP4228	\$204	\$204
1	Stack-on Storage, Sliding Door 78"W x 15"D x 35¼"H	HNL3678SD	\$1,267	\$1,267
1	Storage/File Cabinet, Open Shelves 18"W x 24"D x 64¾"H	HNL241865SFX	\$1,651	\$1,651
TOTAL:			\$5,979	

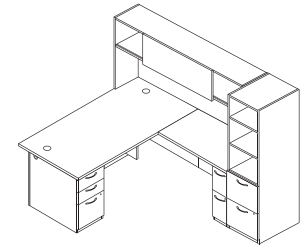
**L-WORKSTATION**

QTY	DESCRIPTION	MODEL	LIST PRICE	PRICE EXTENSION
1	Rectangle Worksurface 72"W x 30"D	HNLRC3072	\$429	\$429
1	Narrow Box/Box/File Pedestal 9½"W x 29⅞"D x 28½"H	HNL291028PBBF	\$772	\$772
1	Full Back Panel — For 9½"W Pedestal 9½"W x 27⅞"H	HNLPB1028	\$125	\$125
1	Laminate Floating Modesty Panel 36"W x 14"H	HLSL3614L	\$179	\$179
1	Bookcase End Support 12"W x 30"D x 28½"H	HNL123028BKE	\$507	\$507
1	Rectangle Worksurface 72"W x 24"D	HNLRC2472	\$366	\$366
1	Shelf/Box/Box/Lateral File Pedestal 36"W x 23⅞"D x 28½"H	HNL233628PSL	\$1,245	\$1,245
1	Storage Cabinet Pedestal 36"W x 23⅞"D x 28½"H	HNL233628PSC	\$810	\$810
1	Modesty/Back Panel — Full-Length 72"W x 27⅞"H	HNLMP7228	\$285	\$285
1	Stack-on Storage, Sliding Door 72"W x 15"D x 35¼"H	HNL3672SD	\$1,229	\$1,229
1	Bookcase with Coat Hooks, 5-Shelf, Left 24"W x 24"D x 64¾"H	HNL2424BK5CL	\$958	\$958
TOTAL:			\$6,905	

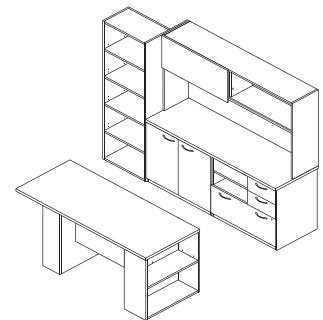
**DESK — CREDENZA — STORAGE**



Icon Legend on page 19

CONCINNITY™ Typicals

DESKS

QTY	DESCRIPTION	MODEL	LIST PRICE	PRICE EXTENSION
1	Rectangle Worksurface 60"W x 24"D	HNLRC2460	\$325	\$325
1	Height Adjustable Base	HHAB3S2L	\$1,120	\$1,120
1	Rectangle Worksurface 84"W x 24"D	HNLRC2484	\$493	\$493
1	End Panel, Left 1½"W x 23⅞"D x 28½"H	HNLEP2428L	\$204	\$204
1	Shelf/Box/Box/Lateral File Pedestal 36"W x 23⅞"D x 28½"H	HNL233628PSL	\$1,245	\$1,245
1	Modesty/Back Panel — Short 84"W x 10"H	HNLMP8410	\$347	\$347
1	Low Back Panel — For 28½"H Pedestal 36"W x 18"H	HNLB3618	\$149	\$149
2	Stack-on Storage, Frosted Doors with Silver Frame 42"W x 15"D x 35¼"H	HNL3642FD	\$1,313	\$2,626
1	Space Saver End Panels for Stack-on Storage ¾"W x 14¼"D x 35¼"H	HNL3605SSEP	\$379	\$379
1	Wardrobe/Storage Cabinet, Hinged Right 18"W x 24"D x 64¾"H	HNL241865WLR	\$1,590	\$1,590

TOTAL: \$8,478

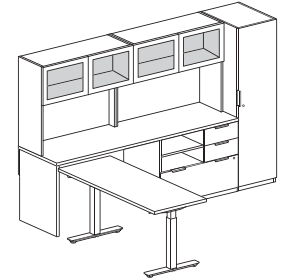

L-WORKSTATION WITH HEIGHT-ADJUSTABLE DESK — OPEN PLAN

QTY	DESCRIPTION	MODEL	LIST PRICE	PRICE EXTENSION
1	Bullet Worksurface 84"W x 30"D	HNLBU3084	\$602	\$602
1	T-Shaped End Panel — For Bullet Worksurface 11⅝"W x 29⅞"D x 28½"H	HNLTEP3028	\$353	\$353
1	Support Column — For Bullet Worksurface 4½" Diameter	HPC190X	\$161	\$161
1	Bridge 48"W x 24"D x 29½"H	HNL2448BF	\$448	\$448
1	Rectangle Worksurface 84"W x 24"D	HNLRC2484	\$493	\$493
1	End Panel, Left 1½"W x 23⅞"D x 28½"H	HNLEP2428L	\$204	\$204
1	Shelf/Box/Box/Lateral File Pedestal 36"W x 23⅞"D x 28½"H	HNL233628PSL	\$1,245	\$1,245
1	Modesty/Back Panel — Full-Length 84"W x 27⅞"H	HNLMP8428	\$347	\$347
2	Stack-on Storage, Laminate Doors 42"W x 15"D x 48⅝"H	HNL4942LD	\$1,206	\$2,412
1	Space Saver End Panels for Stack-on Storage ¾"W x 14¼"D x 48⅝"H	HNL4905SSEP	\$513	\$513

TOTAL: \$6,778

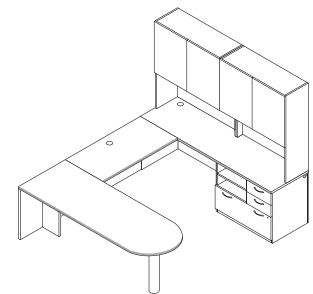

U-WORKSTATION WITH 84" W WORKSURFACE

QTY	DESCRIPTION	MODEL	LIST PRICE	PRICE EXTENSION
1	Left Pedestal Desk, Rectangle Top, Breakfront Frosted Modesty Panel 72"W x 36"D x 29½"H	HNL3672LPRBF	\$2,385	\$2,385
1	Rectangle Worksurface with Vertical Grain 48"W x 24"D	HNLRC2448V	\$274	\$274
1	Modesty/Back Panel — Short 48"W x 10"H	HNLMP4810	\$221	\$221
1	Right Credenza with Lateral File 72"W x 24"D x 29½"H	HNL2472RLC	\$1,584	\$1,584
1	Stack-on Storage, Frosted Doors with Silver Frame 72"W x 15"D x 48⅝"H	HNL4972FD	\$2,571	\$2,571
1	Vertical Paper Manager	HLVPM1	\$327	\$327
1	Wardrobe Left, Bookcase Right 36"W x 24"D x 78⅞"H	HNL243679WLBR	\$2,533	\$2,533

TOTAL: \$9,895

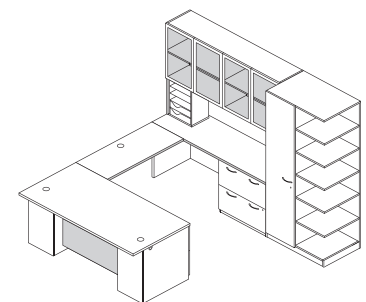

U-WORKSTATION

CONCINNITY™

Typicals



Icon Legend on page 19

QTY	DESCRIPTION	MODEL	LIST PRICE	PRICE EXTENSION
1	Rectangle Worksurface 72"W x 30"D	HNLRC3072	\$429	\$429
1	Rectangle Worksurface with Vertical Grain 42"W x 24"D	HNLRC2442V	\$256	\$256
1	Height Adjustable Base, 3-Leg	HHAB3S3L	\$1,896	\$1,896
1	Mixed Material Floating Modesty Panel 60"W x 14"H	HLSL6014MM	\$1,113	\$1,113
1	Rectangle Worksurface 72"W x 24"D	HNLRC2472	\$366	\$366
1	End Panel, Right 1½"W x 23½"D x 28½"H	HNLEP2428R	\$204	\$204
1	Box/Box/File Pedestal 15¾"W x 23½"D x 28½"H	HNL231628PBBF	\$714	\$714
1	Low Back Panel — For 15¾"W Pedestal 15¾"W x 18"H	HNLLB1618	\$127	\$127
1	Modesty/Back Panel — Short 72"W x 10"H	HNLMP7210	\$285	\$285
1	Wall Mount Storage, Frosted Doors with Silver Frame 72"W x 15"D x 15"H	HNL1572FD	\$1,775	\$1,775
1	Storage/File Cabinet, Hinged Left 18"W x 24"D x 64¾"H	HNL241865SFL	\$1,740	\$1,740
TOTAL:			\$8,905	

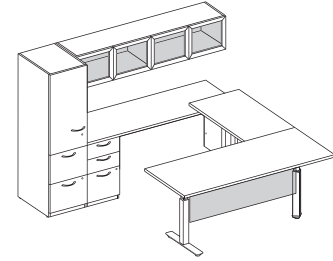

U-WORKSTATION WITH HEIGHT-ADJUSTABLE L-WORKSURFACE

QTY	DESCRIPTION	MODEL	LIST PRICE	PRICE EXTENSION
1	Rectangle Worksurface 72"W x 24"D	HNLRC2472	\$366	\$366
2	O-Leg Support for 24"D Worksurface 24"D x 28½"H	HLSL2428O	\$316	\$632
1	External Support Channel for 72"W Worksurface	HLSLZ5SC78	\$110	\$110
1	Low Credenza, Drawers Left, Bookcase Right 60"W x 20"D x 21½"H	HNL206021LD2	\$1,264	\$1,264
1	Rectangle Worksurface 54"W x 24"D	HNLRC2454	\$299	\$299
1	Standing-Height O-Leg Support for 24"D Worksurface 24"D x 41"H	HLSL2441O	\$424	\$424
1	Narrow Box/Box/File/File Pedestal 9½"W x 23½"D x 41"H	HNL231041PBBFF	\$1,322	\$1,322
1	Full Back Panel — For 41"H Pedestal 9½"W x 40¾"H	HNLBP1041	\$139	\$139
1	Storage Tower, Hinged Left 18"W x 24"D x 50"H	HNL241850TLL	\$1,245	\$1,245
TOTAL:			\$5,801	

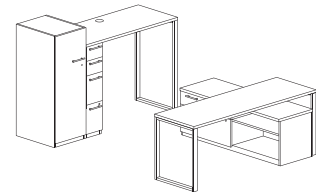

U-WORKSTATION WITH SITTING AND STANDING-HEIGHT WORKSURFACES — OPEN PLAN



Icon Legend on page 19

CONCINNITY™ Typicals

QTY	DESCRIPTION	MODEL	LIST PRICE	PRICE EXTENSION
1	Rectangle Worksurface 72"W x 30"D	HNLRC3072	\$429	\$429
1	O-Leg Support for 30"D Worksurface 30"D x 28½"H	HLSL30280	\$352	\$352
1	O-Leg Support over Low Credenza 30"D x 7"H	HLSL3070	\$271	\$271
1	External Support Channel for 72"W Worksurface	HLSLZ5SC78	\$110	\$110
1	Low Credenza, Drawers Right, Bookcase Left 60"W x 20"D x 21½"H	HNL206021RD2	\$1,264	\$1,264
1	Low Credenza, Drawers Left, Bookcase Right 60"W x 20"D x 21½"H	HNL206021LD2	\$1,264	\$1,264
2	Wall Mount Storage, Laminate Doors 30"W x 15"D x 28½"H	HNL2930LD	\$819	\$1,638
1	Wall Mount Storage, Frosted Doors with Silver Frame 30"W x 15"D x 28½"H	HNL2930FD	\$1,284	\$1,284
1	Wall Mount 30"W x 48⅝"H	HNL4930WB	\$231	\$231

TOTAL: \$6,843

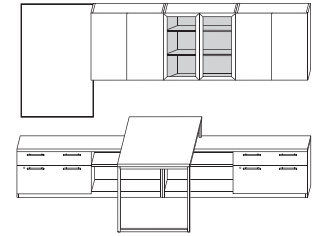

**WORKSTATION WITH
WORKWALL – OPEN PLAN**

QTY	DESCRIPTION	MODEL	LIST PRICE	PRICE EXTENSION
3	Rectangle Worksurface with Vertical Grain 48"W x 24"D	HNLRC2448V	\$274	\$822
3	O-Leg Support for 48"W x 24"D Worksurface 24"D x 28½"H	HLSL24280	\$316	\$948
3	Mixed Material Floating Modesty Panel 42"W x 14"H	HLSL4214MM	\$811	\$2,433
3	Rectangle Worksurface 72"W x 24"D	HNLRC2472	\$366	\$1,098
3	L-Shaped End Panel, Left 15¾"W x 24"D x 28½"H	HNLLEP2428L	\$332	\$996
3	Shelf/Box/Box/Lateral File Pedestal 30"W x 23⅜"D x 28½"H	HNL233028PSL	\$1,221	\$3,663
3	Modesty/Pedestal Back Panel 30"W x 27⅞"H	HNLMP3028	\$175	\$525
3	Wall Mount Storage, Frosted Doors with Silver Frame 72"W x 15"D x 15"H	HNL1572FD	\$1,775	\$5,325

TOTAL: \$15,810

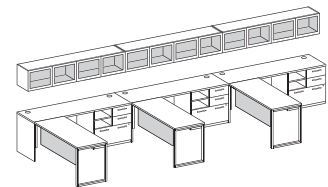

L-WORKSTATIONS – OPEN PLAN

CONCINNITY™

Typicals



Icon Legend on page 19

QTY	DESCRIPTION	MODEL	LIST PRICE	PRICE EXTENSION
1	Rectangle Worksurface with Vertical Grain 48"W x 24"D	HNLRC2448V	\$274	\$274
1	O-Leg Support for 48"W x 24"D Worksurface 24"D x 28½"H	HLSL2428O	\$316	\$316
1	Rectangle Worksurface 96"W x 24"D	HNLRC2496	\$532	\$532
1	Storage Cabinet Pedestal 36"W x 23⅞"D x 28½"H	HNL233628PSC	\$810	\$810
1	End Panel, Left 1⅞"W x 23⅞"D x 28½"H	HNLEP2428L	\$204	\$204
1	Modesty/Back Panel — Full-Length 96"W x 27⅞"H	HNLMP9628	\$430	\$430
1	Bookcase Hutch, Frosted Doors with Silver Frame 36"W x 15"D x 48⅝"H	HNL4936BHFD	\$1,678	\$1,678
1	Wall Mount Storage, Frosted Doors with Silver Frame 60"W x 15"D x 28½"H	HNL2960FD	\$2,217	\$2,217
1	Vertical Paper Manager	HLVPM1	\$327	\$327
1	Storage Tower, Wardrobe Right, Cabinet Left 24"W x 24"D x 78⅞"H	HNL242465TLR	\$2,235	\$2,235
TOTAL:			\$9,023	

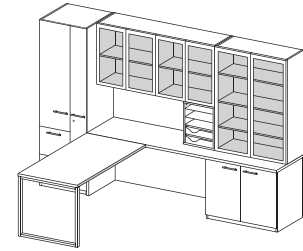

WORKSTATION WITH WORKWALL — OPEN PLAN

QTY	DESCRIPTION	MODEL	LIST PRICE	PRICE EXTENSION
4	Rectangle Worksurface 60"W x 24"D	HNLRC2460	\$325	\$1,300
4	Shelf/Box/Box/File Pedestal 15¾"W x 23⅞"D x 41"H	HNL231641PSBBF	\$1,503	\$6,012
4	Full Back Panel — For 15¾"W Pedestal 15¾"W x 40⅝"H	HNLPB1641	\$153	\$612
4	Narrow Box/Box/File/File Pedestal 9½"W x 23⅞"D x 41"H	HNL231041PBFF	\$1,322	\$5,288
4	Full Back Panel — For 9½"W Pedestal 9½"W x 40⅝"H	HNLPB1041	\$139	\$556
2	Above/Below Privacy Screen, Frosted 30"W x 28"H	HLSL2830	\$800	\$1,600
2	5-Shelf Bookcase with Coat Hooks, Right 24"W x 24"D x 64¾"H	HNL2424BK5CR	\$958	\$1,916
2	5-Shelf Bookcase with Coat Hooks, Left 24"W x 24"D x 64¾"H	HNL2424BK5CL	\$958	\$1,916
TOTAL:			\$19,200	

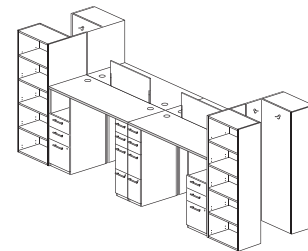

STANDING-HEIGHT — TEAMING WORKSTATION — OPEN PLAN



Icon Legend on page 19

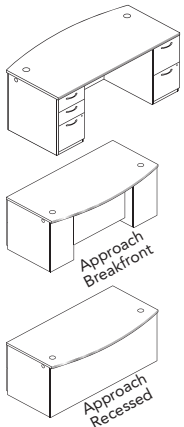

DESCRIPTION	APPROACH SIDE OVERHANG	MODEL	SHIP WEIGHT	CUBE	L1 LIST	L2 UPCHARGES		
						WORKSURFACES	CHASSIS	FRONTS
Double Pedestal Desk — Bow Top 72"W x 36"D x 29½"H, Recessed Modesty Panel	6"	HNL3672DPBR	298	51.8	\$2309	\$25	\$40	\$10
72"W x 36"D x 29½"H, Breakfront Modesty Panel	6-12"	HNL3672DPBB	282	51.8	\$2400	\$25	\$40	\$10
72"W x 36"D x 29½"H, Breakfront Frosted Modesty Panel	6-12"	HNL3672DPBBF	266	51.8	\$2883	\$25	\$40	\$10

NOTES: For laminate center drawer, see page 106. For pull-out collaborative shelf, for desks with breakfront modesty panel, see page 106.

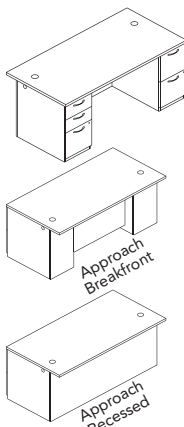

Double Pedestal Desk — Rectangle Top 72"W x 36"D x 29½"H, Rectangle Top, Recessed Modesty Panel	6"	HNL3672DPRR	292	51.8	\$1955	\$25	\$40	\$10
66"W x 30"D x 29½"H, Rectangle Top, Flush Modesty Panel		HNL3066DPRF	267	40.2	\$1838	\$20	\$35	\$10
60"W x 30"D x 29½"H, Rectangle Top, Flush Modesty Panel		HNL3060DPRF	257	40.2	\$1718	\$20	\$45	\$20
72"W x 36"D x 29½"H, Rectangle Top, Breakfront Modesty Panel	6-12"	HNL3672DPRB	287	51.8	\$2175	\$25	\$40	\$10
72"W x 36"D x 29½"H, Rectangle Top, Breakfront Frosted Modesty Panel	6-12"	HNL3672DPRBF	270	51.8	\$2658	\$25	\$40	\$10

NOTES: For laminate center drawer, see page 106. For pull-out collaborative shelf, for desks with breakfront modesty panel, see page 106.

NOTES:

- Feature full-to-the-floor pedestals to maximize storage space.
- Double pedestal desks have 3/2 drawer configuration (box/box/file on left pedestal, file/file on right pedestal).
- Single pedestal desks have a box/box/file pedestal.
- One molded black pencil tray is included in each box/box/file pedestal.
- 72"W models are available with Rectangle- or bow-shaped tops.
- Bow top desk models measure 36"D at the crest and 30"D along the end panels.
- Formal breakfront or recessed modesty panel.
- Breakfront desk features a floating modesty panel which can be specified in laminate or frosted material. Floating design provides space for optional pull-out collaborative shelf for visitors. See page 106.
- Recessed modesty panel design has a full-width conference overhang, providing worksurface and kneespace for guests.
- 66"W and 60"W desks have a flush modesty panel (i.e., no conference overhang).
- Two cord management grommets, for routing and hiding wires and cables, are located in desktops.
- Grommets can be replaced with optional Power (model HGRMTAC) or USB Hub (HGRMTUSB2).
- Pedestal sides and end panels are standard with pass-through grommets to enable the routing of cords below the worksurface, and connections between workstations.
- Specification logic includes the grommet finish for tops; choose from Black (P) or Platinum (T1). Side grommets on pedestal are black only.
- See "Modular Components" for cord management options. Worksurfaces/tops, end and modesty panels, and pedestals can be specified with or without grommets.
- Finish of pedestal lock(s) is determined by, and aligned with, the handle finish specified.
- Adjustable hex leveling glides.
- Ship fully assembled.

HOW TO SPECIFY

Select Model Number	Select Edge Profile and Edge Color	Select Handle	Select Worksurface Grommet Finish	Select Worksurface Color	Select Chassis Color	Select Drawer Front Color
See page 29	See page 29	A Cylinder – Satin B Cylinder – Black C Canopy – Satin D Canopy – Black E Loop – Satin F Loop – Black	P Black T1 Platinum	See page 29	See page 29	See page 29
H N L 3 6 7 2 D P B R .	B H .	E .	T 1 .	H .	H .	H .

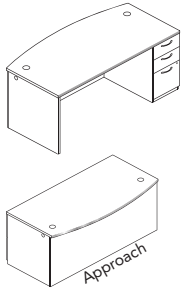

DESCRIPTION	APPROACH SIDE OVERHANG	MODEL	SHIP WEIGHT	CUBE	L1 LIST	L2 UPCHARGES		
						WORKSURFACES	CHASSIS	FRONTS
Single Pedestal Desk — Bow Top 72"W x 36"D x 29½"H, Right, Recessed Modesty Panel (shown)	6"	HNL3672RPBR	238	51.8	\$1856	\$25	\$40	\$10
72"W x 36"D x 29½"H, Left, Recessed Modesty Panel	6"	HNL3672LPBR	238	51.8	\$1856	\$25	\$40	\$10
72"W x 36"D x 29½"H, Right, Breakfront Modesty Panel	6-12"	HNL3672RPBB	237	51.8	\$2091	\$25	\$40	\$10
72"W x 36"D x 29½"H, Left, Breakfront Modesty Panel	6-12"	HNL3672LPBB	237	51.8	\$2091	\$25	\$40	\$10
72"W x 36"D x 29½"H, Right, Breakfront Frosted Modesty Panel	6-12"	HNL3672RPBBF	221	51.8	\$2565	\$25	\$40	\$10
72"W x 36"D x 29½"H, Left, Breakfront Frosted Modesty Panel	6-12"	HNL3672LPBBF	221	51.8	\$2565	\$25	\$40	\$10

NOTES: For laminate center drawer, see page 106. For pull-out collaborative shelf, for desks with breakfront modesty panel, see page 106.

NOTES:

- Feature full-to-the-floor pedestals to maximize storage space.
- Double pedestal desks have 3/2 drawer configuration (box/box/file on left pedestal, file/file on right pedestal).
- Single pedestal desks have a box/box/file pedestal.
- One molded black pencil tray is included in each box/box/file pedestal.
- 72"W models are available with Rectangle- or bow-shaped tops.
- Bow top desk models measure 36"D at the crest and 30"D along the end panels.
- Formal breakfront or recessed modesty panel.
- Breakfront desk features a floating modesty panel which can be specified in laminate or frosted material. Floating design provides space for optional pull-out collaborative shelf for visitors. See page 106.
- Recessed modesty panel design has a full-width conference overhang, providing workspace and kneespace for guests.
- 66"W and 60"W desks have a flush modesty panel (i.e., no conference overhang).
- Two cord management grommets, for routing and hiding wires and cables, are located in desktops.
- Grommets can be replaced with optional Power (model HGRMTAC) or USB Hub (HGRMTUSB2).
- Pedestal sides and end panels are standard with pass-through grommets to enable the routing of cords below the workspace, and connections between workstations.
- Specification logic includes the grommet finish for tops; choose from Black (P) or Platinum (TI). Side grommets on pedestal are black only.
- See "Modular Components" for cord management options. Worksurfaces/tops, end and modesty panels, and pedestals can be specified with or without grommets.
- Finish of pedestal lock(s) is determined by, and aligned with, the handle finish specified.
- Adjustable hex leveling glides.
- Ship fully assembled.

HOW TO SPECIFY

Select Model Number	Select Edge Profile and Edge Color	Select Handle	Select Worksurface Grommet Finish	Select Worksurface Color	Select Chassis Color	Select Drawer Front Color
See page 29	See page 29	See page 29	See page 29	See page 29	See page 29	See page 29
H N L 3 6 7 2 R P B R	B H	E	T 1	H	H	H



Icon Legend on page 19

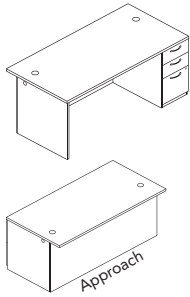

DESCRIPTION	APPROACH SIDE OVERHANG	MODEL	SHIP WEIGHT	CUBE	L1 LIST	L2 UPCHARGES		
						WORKSURFACES	CHASSIS	FRONTS
Single Pedestal Desk — Rectangle Top 72"W x 36"D x 29½"H, Right, Recessed Modesty Panel (shown)	6"	HNL3672RPRR	242	51.8	\$1602	\$25	\$40	\$10
72"W x 36"D x 29½"H, Left, Recessed Modesty Panel	6"	HNL3672LPRR	242	51.8	\$1602	\$25	\$40	\$10
66"W x 30"D x 29½"H, Right, Flush Modesty Panel		HNL3066RPRF	217	40.2	\$1564	\$20	\$35	\$10
66"W x 30"D x 29½"H, Left, Flush Modesty Panel		HNL3066LPRF	217	40.2	\$1564	\$20	\$35	\$10
72"W x 36"D x 29½"H, Right, Breakfront Modesty Panel	6-12"	HNL3672RPRB	242	51.8	\$1911	\$25	\$40	\$10
72"W x 36"D x 29½"H, Left, Breakfront Modesty Panel	6-12"	HNL3672LPRB	242	51.8	\$1911	\$25	\$40	\$10
72"W x 36"D x 29½"H, Right, Breakfront Frosted Modesty Panel	6-12"	HNL3672RPRBF	225	51.8	\$2385	\$25	\$40	\$10
72"W x 36"D x 29½"H, Left, Breakfront Frosted Modesty Panel	6-12"	HNL3672LPRBF	225	51.8	\$2385	\$25	\$40	\$10

NOTES: For laminate center drawer, see page 106. For pull-out collaborative shelf, for desks with breakfront modesty panel, see page 106.

NOTES:

- Feature full-to-the-floor pedestals to maximize storage space.
- Double pedestal desks have 3/2 drawer configuration (box/box/file on left pedestal, file/file on right pedestal).
- Single pedestal desks have a box/box/file pedestal.
- One molded black pencil tray is included in each box/box/file pedestal.
- 72"W models are available with Rectangle- or bow-shaped tops.
- Bow top desk models measure 36"D at the crest and 30"D along the end panels.
- Formal breakfront or recessed modesty panel.
- Breakfront desk features a floating modesty panel which can be specified in laminate or frosted material. Floating design provides space for optional pull-out collaborative shelf for visitors. See page 106.
- Recessed modesty panel design has a full-width conference overhang, providing workspace and kneespace for guests.
- 66"W and 60"W desks have a flush modesty panel (i.e., no conference overhang).
- Two cord management grommets, for routing and hiding wires and cables, are located in desktops.
- Grommets can be replaced with optional Power (model HGRMTAC) or USB Hub (HGRMTUSB2).
- Pedestal sides and end panels are standard with pass-through grommets to enable the routing of cords below the worksurface, and connections between workstations.
- Specification logic includes the grommet finish for tops; choose from Black (P) or Platinum (T1). Side grommets on pedestal are black only.
- See "Modular Components" for cord management options. Worksurfaces/tops, end and modesty panels, and pedestals can be specified with or without grommets.
- Finish of pedestal lock(s) is determined by, and aligned with, the handle finish specified.
- Adjustable hex leveling glides.
- Ship fully assembled.

HOW TO SPECIFY

Select Model Number	Select Edge Profile and Edge Color	Select Handle	Select Worksurface Grommet Finish	Select Worksurface Color	Select Chassis Color	Select Drawer Front Color
	See page 29	A Cylinder – Satin B Cylinder – Black C Canopy – Satin D Canopy – Black E Loop – Satin F Loop – Black	P Black T1 Platinum	See page 29	See page 29	See page 29
H N L 3 6 7 2 R P R R .	B H .	E .	T 1 .	H .	H .	H .

CONCINNITY™

Peninsulas

GSA SIN 33721



Icon Legend on page 19

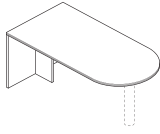

Support column sold separately



DESCRIPTION	MODEL	SHIP WEIGHT	CUBE	L1 LIST	L2 UPCHARGES	
					WORKSURFACE	CHASSIS
Bullet Peninsula with End Panel						
72"W x 36"D x 29½"H	HNL3672BUEP	131	6.6	\$898	\$25	\$40
72"W x 30"D x 29½"H	HNL3072BUEP	112	5.6	\$782	\$20	\$25
66"W x 30"D x 29½"H	HNL3066BUEP	105	5.1	\$702	\$20	\$35

NOTES: For use in "U" or "L" shaped furniture layouts; not to be used freestanding. Comprised of top and end/brace panels (Note: Must specify support column; sold separately). Cord routing notch in the brace panel. Adjustable hex leveling glides. For cord grommet options, see "Modular Components". Options include center drawers and modesty panels. Modesty panel is available in laminate or frosted material. Ships

Not designed to be used freestanding.

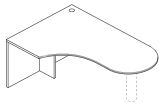
Right-hand model
HNL4872JREP shown

Support column sold separately



DESCRIPTION	MODEL	SHIP WEIGHT	CUBE	L1 LIST	L2 UPCHARGES	
					WORKSURFACE	CHASSIS
Jetty Peninsula with End Panel						
72"W x 30/48"D x 29½"H, Right	HNL4872JREP	147	8.9	\$1079	\$30	\$25
72"W x 30/48"D x 29½"H, Left	HNL4872JLEP	147	8.9	\$1079	\$30	\$25
72"W x 30/42"D x 29½"H, Right	HNL4272JREP	134	17.0	\$1003	\$30	\$25
72"W x 30/42"D x 29½"H, Left	HNL4272JLEP	134	17.0	\$1003	\$30	\$25

NOTES: Worksurface designed and sized to efficiently serve as both a computing and conferencing space. Two sizes, 42"D and 48"D. The 48"D unit is specifically intended to be used with the 48"D extended corner modular top/back components to form a two-piece U-shaped workstation with a 42" cockpit area. For use in "U" or "L" shaped furniture layouts; not to be used freestanding. Comprised of top and end/brace panels (Note: Must specify support column; sold separately). One cord management grommet in the top; cord routing notch in the brace panel. Adjustable hex leveling glides. Field installable modesty panel is optional. Ships

Not designed to be used freestanding.

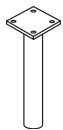

DESCRIPTION	MODEL	SHIP WEIGHT	CUBE	LIST PRICE
Support Column for Bullet and Jetty Peninsulas 4½" Diameter. Specify: HPC190X.P. Black only.	HPC190X	12	1.0	\$161
Support Column for Bullet and Jetty Peninsulas 4½" Diameter. Specify: HPC191X.X. Available in Silver only.	HPC191X	12	1.0	\$161

Support Column must be specified/ordered with Bullet and Jetty peninsulas.

NOTES:



- See pages 92-96 for shared components.

HOW TO SPECIFY

Select Model Number H N L 3 6 7 2 B U E P	Select Edge Profile and Edge Color See page 29 B H	Select Worksurface Color See page 29 H	Select Chassis Color See page 29 H
Select Model Number H N L 4 8 7 2 J R E P	Select Edge Profile and Edge Color See page 29 B H	Select Worksurface Grommet Finish P Black T1 Platinum	Select Worksurface Color See page 29 H
			Select Chassis Color See page 29 H

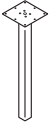

Icon Legend on page 19

	DESCRIPTION	MODEL	SHIP WEIGHT	CUBE	LIST PRICE BY PAINT GRADE		
					P1	P2	P3
	Post Leg Base 28½" H x 2" square NOTES: Can only be used as the outbound support in a peninsula or island extension worksurface application. Glides have 2" of adjustability. Ship 1/pack. SPECIFYING EXAMPLE: HLSL28P.T1	HLSL28P	15	1.0	\$292	\$296	\$312
	Field Installable Modesty Panel for Bullet and Jetty Peninsulas, Laminate (Vertical Grain) 50¼"W x ¾" Thick x 18"H NOTES: Center drawer model H1522 can be used in conjunction with laminate modesty panel model HPC180W. Cord pass-through notch in top corner. SPECIFYING EXAMPLE: HPC180W.H	HPC180W	28	3.6	\$215		
	Field Installable Modesty Panel for Bullet and Jetty Peninsulas, Frosted with Silver Frame 50¼"W x ¾" Thick x 18"H ⓘ Cord pass-through notch is not available on the Frosted/Silver model HPC180G. Notch is on laminate model HPC180W only. ⓘ Center drawers not designed to be used with the frosted/silver modesty panel model HPC180G.	HPC180G	33	1.5	\$694		

NOTES:

- See pages 92-96 for shared components.

HOW TO SPECIFY

Select Model Number

H	L	S	L	2	8	P
---	---	---	---	---	---	---

CONCINNITY™

Corner Unit

GSA SIN 33721



Icon Legend on page 19

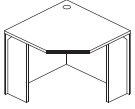

DESCRIPTION	MODEL	SHIP WEIGHT	CUBE	L1 LIST	L2 UPCHARGES	
					WORKSURFACE	CHASSIS
Corner Unit 24"W x 36"D x 24" x 29½"H	HNL3636CU	109	26.4	\$944	\$15	\$20
NOTES: Designed for use with 24"D returns or bridges. Can be used freestanding. Can be used with two 36"W modular returns to achieve an efficient 6' x 6' layout. One cord management grommet in the top; cord routing notches in the leg panels. The worksurface grommet can be replaced with optional power (model HGRMTAC) or USB (model HGRMTUSB2) hub. Adjustable hex leveling glides. When connected to a 42"W return or modular return, the 78"W stack-on storage unit spans the total depth dimension (78"D). When connected to a 36"W modular return, the 72"W stack-on storage unit spans the total depth dimension (72"D). Edgebanding on the corner unit is profiled on the user's side and flat on the back (approach side) and ends. Ships fully assembled.						

NOTES:

- For Extended Corner Worksurface sizes, see "Modular Components" on page 78.

HOW TO SPECIFY

Select
Model Number

H N L 3 6 3 6 C U .

Select
Edge Profile and Edge
Color

See page 29

B H .

Select
Worksurface Grommet
Finish

P Black
T1 Platinum

P .

Select
Worksurface Color

See page 29

H .

Select
Chassis Color

See page 29

H

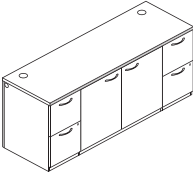
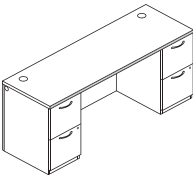
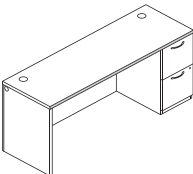
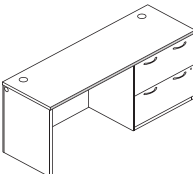

DESCRIPTION	MODEL	SHIP WEIGHT	CUBE	L1 LIST	L2 UPCHARGES		
					WORKSURFACES	CHASSIS	FRONTS
 <p>Credenza with Storage 72"W x 24"D x 29½"H</p> <p>NOTES: For use behind a desk or as a stand-alone storage piece. Four file drawers, 2-left, 2-right and one storage cabinet with hinged doors. One adjustable shelf, which adjusts in 2½" increments, behind doors. Drawers lock. Finish of locks is determined by, and aligned with, the handle finish specified. Storage cabinet doors are non-locking.</p>	HNL2472DPS	323	35.6	\$2403	\$20	\$45	\$40
 <p>Credenza with Kneespace 72"W x 24"D x 29½"H 66"W x 24"D x 29½"H 60"W x 24"D x 29½"H</p> <p>NOTES: For use behind a desk or as a stand-alone storage piece. Four locking file drawers, 2-left, 2-right. Finish of locks determined by, and aligned with, the handle finish specified.</p>	HNL2472DPK	247	35.6	\$1818	\$20	\$40	\$20
	HNL2466DPK	239	32.7	\$1735	\$20	\$40	\$20
	HNL2460DPK	230	29.9	\$1706	\$20	\$35	\$20
 <p>Credenza, Single Pedestal 72"W x 24"D x 29½"H, Right 72"W x 24"D x 29½"H, Left</p> <p>NOTES: Primary use is as part of a connected U-shaped workstation with a bridge and single pedestal desk. Two locking file drawers. Finish of lock determined by, and aligned with, the handle finish specified. Can be used with modular or mobile pedestals.</p>	HNL2472RP	199	35.6	\$1449	\$20	\$35	\$10
	HNL2472LP	199	35.6	\$1449	\$20	\$35	\$10
 <p>Credenza with Lateral File 72"W x 24"D x 29½"H, Right 72"W x 24"D x 29½"H, Left</p> <p>NOTES: Storage file measures 30"W (36"W can be specified using modular components). Mechanical interlock inhibits the extension of more than one drawer at a time. Finish of lock is determined by, and aligned with, the handle finish specified. Can be used with modular or mobile pedestals.</p>	HNL2472RLC	245	35.6	\$1584	\$20	\$35	\$20
	HNL2472LLC	245	35.6	\$1584	\$20	\$35	\$20

NOTES:

- Optional 72"W, 66"W and 60"W stack-on sizes maximize storage space.
- Two cord management grommets, for routing and hiding wires and cables, are located in top.
- Modesty panel and pedestal grommets are black only.
- A cord pass-through grommet is located in the sides of the pedestal and top center of the back (modesty panel) to facilitate reaching wall electrical outlets.
- Specification logic includes the grommet finish for tops; choose from Black (P) or Platinum (T1).
- Worksurfaces/tops, end and modesty panels, and pedestals can be specified with or without grommets. See "Modular Components" on page 36 for cord management options.
- For paper organizers, see page 110.

HOW TO SPECIFY

<p>Select Model Number</p> <p>See page 29</p> <p>H N L 2 4 7 2 D P S</p>	<p>Select Edge Profile and Edge Color</p> <p>See page 29</p> <p>B H</p>	<p>Select Handle</p> <p>A Cylinder – Satin B Cylinder – Black C Canopy – Satin D Canopy – Black E Loop – Satin F Loop – Black</p> <p>E</p>	<p>Select Worksurface Grommet Finish</p> <p>P Black T1 Platinum</p> <p>T 1</p>	<p>Select Worksurface Color</p> <p>See page 29</p> <p>H</p>	<p>Select Chassis Color</p> <p>See page 29</p> <p>H</p>	<p>Select Drawer Front Color</p> <p>See page 29</p> <p>H</p>
--	---	--	--	---	---	--

CONCINNITY™

Low Credenzas

GSA SIN 33721



Icon Legend on page 19

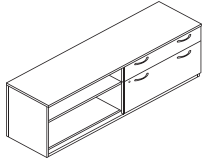

DESCRIPTION	MODEL	SHIP WEIGHT	CUBE	L1 LIST	L2 UPCHARGES		
					WORKSURFACES	CHASSIS	FRONTS
Low Credenza (Bench-Height) 72"W x 20"D x 21½"H, Drawers Right, Bookcase Left (shown)	HNL207221RD2	219	21.6	\$1408	\$15	\$25	\$20
72"W x 20"D x 21½"H, Drawers Left, Bookcase Right	HNL207221LD2	219	21.6	\$1408	\$15	\$25	\$20
60"W x 20"D x 21½"H, Drawers Right, Bookcase Left	HNL206021RD2	187	18.1	\$1264	\$20	\$15	\$20
60"W x 20"D x 21½"H, Drawers Left, Bookcase Right	HNL206021LD2	187	18.1	\$1264	\$20	\$15	\$20

NOTES: Combination storage design comprised of two locking drawers (1-box/supply and 1-file) plus a bookcase. File drawers include integrated hangrails for letter- or legal-sized folders. Bookcase has one adjustable shelf; adjusts in 2½" increments.

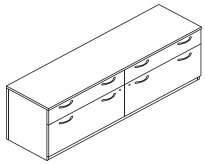

Low Credenza, 2 Box/2 File 72"W x 20"D x 21½"H	HNL207221D4	308	21.6	\$1712	\$15	\$25	\$40
60"W x 20"D x 21½"H	HNL206021D4	260	18.1	\$1517	\$15	\$20	\$40

NOTES: Four locking drawers (2-box/supply and 2-file). File drawers include integrated hangrails for letter- or legal-sized folders.

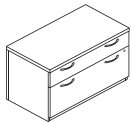

Low Credenza, Box/File 36"W x 20"D x 21½"H	HNL203621D2	143	11.8	\$992	\$10	\$15	\$20
30"W x 20"D x 21½"H	HNL203021D2	121	10.0	\$932	\$10	\$15	\$20

NOTES: Unit contains two drawers, one box and one lateral file.

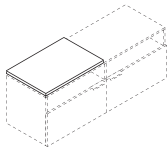

DESCRIPTION	MODEL	SHIP WEIGHT	CUBE	LIST PRICE BY FABRIC GRADE					
				1	2	3	4	5	6
Credenza Cushion 36"W x 20"D x 1"H for 72" and 36"W Low Credenzas	HLSL2036CH2	11	2.2	\$402	\$440	\$478	\$517	\$566	\$616
30"W x 20"D x 1"H for 60" and 30"W Low Credenzas	HLSL2030CH2	9	1.9	\$372	\$408	\$444	\$480	\$526	\$573

NOTES: See pages 22-24 for available fabrics.

Seat cushions are optional; HLSL2036CH2 for 72" and 36"W, HLSL2030CH2 for 60" and 30"W.

! For model HLSL2030CH2 must order two cushions to cover entire 60" Credenza surface.

SPECIFYING EXAMPLE: HLSL2036CH2.APN23

NOTES:

- Versatile, space-saving solutions double as a compact storage unit and convenient bench seat.
- When combined with 29½"H worksurfaces, the 21½"H credenzas can be positioned to create multi-level, overlapping surfaces that optimize floor space, organization and display needs.
- The distinct, clean horizontal planes provide a light scale, layered look.
- Low-heights help facilitate team collaboration.
- Finish of lock(s) is determined by, and aligned with, the handle finish specified.
- Overlapping surfaces can be supported by a 28½"H or 7"H O-leg or 7"H laminate end panel.

HOW TO SPECIFY

Select Model Number H N L 2 0 7 2 2 1 R D 2 .	Select Edge Profile and Edge Color See page 29 B H .	Select Handle A Cylinder - Satin B Cylinder - Black C Canopy - Satin D Canopy - Black E Loop - Satin F Loop - Black E .	Select Top Color See page 29 H .	Select Chassis Color See page 29 H .	Select Drawer Front Color See page 29 H .
---	---	---	---	---	--



Icon Legend on page 19

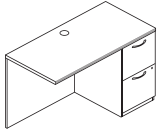

DESCRIPTION	MODEL	SHIP		L1 LIST	L2 UPCHARGES		
		WEIGHT	CUBE		WORKSURFACES	CHASSIS	FRONTS
Return							
48"W x 24"D x 29½"H, Right (shown)	HNL2448RP	141	24.8	\$1039	\$15	\$15	\$10
48"W x 24"D x 29½"H, Left	HNL2448LP	141	24.8	\$1039	\$15	\$15	\$10
42"W x 24"D x 29½"H, Right	HNL2442RP	132	22.0	\$996	\$15	\$15	\$10
42"W x 24"D x 29½"H, Left	HNL2442LP	132	22.0	\$996	\$15	\$15	\$10

NOTES: For L-shaped workstations. Connects to single pedestal desk, peninsula (bullet or jetty), or component worksurface with end panel. Drawers lock. Finish of lock is determined by, and aligned with, the handle finish specified. Formal, full-height modesty panel. One cord grommet in top for routing and hiding wires and cables. One cord pass-through grommet is located in the sides of the pedestal and top center of the back (modesty panel) to facilitate reaching wall electrical outlets. Specification logic includes the grommet finish for tops; choose from Black (P) or Platinum (TI). Modesty panel and pedestal grommets are black only. Edgebanding on 42"W and 48"W returns is profiled on the user's side and flat on the back (approach side) and ends. Woodgrain direction on worksurface runs vertical (i.e., front-to-back). Smaller and larger return sizes can be specified using modular worksurface and modesty panel components. Optional stack-on solutions maximize storage space. Ship fully assembled.

See chart on page 36 for cord management options. Worksurfaces/tops, end and modesty panels, and pedestals can be specified with or without grommets. For easy access to wall electrical outlets, options include a short (10") modesty panel or no back panel.

For paper organizers, see page 110.

HOW TO SPECIFY

<p>Select Model Number</p>	<p>Select Edge Profile and Edge Color</p> <p>See page 29</p>	<p>Select Handle</p> <p>A Cylinder – Satin B Cylinder – Black C Canopy – Satin D Canopy – Black E Loop – Satin F Loop – Black</p>	<p>Select Worksurface Grommet Finish</p> <p>P Black TI Platinum</p>	<p>Select Worksurface Color</p> <p>See page 29</p>	<p>Select Chassis Color</p> <p>See page 29</p>	<p>Select Drawer Front Color</p> <p>See page 29</p>
<p>H N L 2 4 4 8 R P .</p>	<p>B H .</p>	<p>E .</p>	<p>T I .</p>	<p>H .</p>	<p>H .</p>	<p>H .</p>

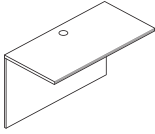

DESCRIPTION	MODEL	SHIP WEIGHT	CUBE	L1 LIST	L2 UPCHARGES		
					WORKSURFACES	CHASSIS	FRONTS
Bridge 48"W x 24"D x 29½"H	HNL2448BF	71	3.0	\$448	\$15	\$15	N/A
42"W x 24"D x 29½"H	HNL2442BF	62	2.5	\$428	\$15	\$15	N/A

NOTES: For U-shaped workstation layouts. Connects single pedestal desk, peninsula (bullet or jetty), or component worksurface to corner unit or to single pedestal credenza, credenza with lateral file, or rectangle worksurface. Formal, full-height modesty panel. One cord grommet in top for routing and hiding wires and cables. One cord pass-through grommet in top center of back (modesty panel). Specification logic includes the grommet finish for tops; choose from Black (P) or Platinum (T1). Clear inside depth 22⁷/₈"D. Edgebanding on 42"W and 48"W bridges is profiled on the user's side and flat on the back (approach side) and ends. Woodgrain direction on worksurface runs vertical (i.e., front-to-back). Additional sizes, including 30"W and 36"W for use with corner or extended corner units, as well as jetty peninsulas, can be specified using modular worksurface and modesty panel components. Ship — quick, simple assembly. See chart on page 36 for cord management options. Worksurfaces/tops and modesty panels can be specified with or without grommets. For easy access to wall electrical outlets, options include a short (10") modesty panel or no back panel.

HOW TO SPECIFY

<p>Select Model Number</p> <p>H N L 2 4 4 8 B F .</p>	<p>Select Edge Profile and Edge Color</p> <p>See page 29</p> <p>B H .</p>	<p>Select Worksurface Grommet Finish</p> <p>P Black T1 Platinum</p> <p>P .</p>	<p>Select Worksurface Color</p> <p>See page 29</p> <p>H .</p>	<p>Select Chassis Color</p> <p>See page 29</p> <p>H .</p>
--	--	---	--	--

CONCINNITY™ STACK-ON STORAGE APPLICATIONS

STACK-ON STORAGE APPLICATIONS

78"W

- Spans full-width of 78"W modular credenza or return.
- Spans total depth dimension of "L" workstation configurations comprised of:
 - 48"W return or modular return attached to a 36"D single pedestal desk with a bow front (78"D).
 - NOTE: The 36"D single pedestal desk with bow front is 30"D along end panel.
 - 48"W return or modular return attached to a 30"D single pedestal desk, modular desk, or bullet peninsula (78"D).
 - 42"W return or modular return attached to a 36"D single pedestal desk with rectangle top, modular desk, or bullet peninsula (78"D).
 - 42"W return or modular return attached to a 36" corner unit or 36"D extended corner unit (78"D).
 - 36"W modular return attached to a 42"D jetty peninsula (78"D).
 - 30"W modular return attached to a 48"D jetty peninsula (78"D).
 - 30"W modular return attached to a 48"D extended corner unit (78"D).

72"W

- Spans full-width of 72"W desks with rectangle top, credenzas, extended corner units, or modular desk, credenza, or return.
- Spans total depth dimension of "L" workstation configurations comprised of:
 - 48"W return or modular return attached to a 24"D single pedestal credenza or modular credenza (72"D).
 - 42"W return or modular return attached to a 36"D single pedestal desk with a bow front (72"D).
 - NOTE: The 36"D single pedestal desk with bow front is 30"D along end panel.
 - 42"W return or modular return attached to a 30"D single pedestal desk, modular desk, or bullet peninsula (72"D).
 - 36"W modular return attached to a 36"D single pedestal desk with rectangle top, modular desk, or bullet peninsula (72"D).
 - 36"W modular return attached to a 36" corner unit or 36"D extended corner unit (72"D).
 - 30"W modular return attached to a 42"D jetty peninsula (72"D).

66"W

- Spans full-width of 66"W desk, credenza, or modular desk, credenza, or return.
- Spans total depth dimension of "L" workstation configurations comprised of:
 - 42"W return or modular return attached to a 24"D single pedestal credenza or modular credenza (66"D).

- 36"W modular return attached to a 30"D single pedestal desk, bullet peninsula, or modular desk (66"D).
- 36"W modular return attached to a 36"D single pedestal desk with a bow front (66"D).
 - NOTE: The 36"D single pedestal desk with bow front is 30"D along end panel.
- 30"W modular return attached to a 36"D single pedestal desk with rectangle top or modular desk (66"D).
- 30"W modular return attached to a 36" corner unit (66"D).

60"W

- Spans full-width of 60"W desk, credenza, or modular desk, credenza, or return.
- Spans total depth dimension of "L" workstation configurations comprised of:
 - 36"W modular return attached to a 24"D single pedestal credenza or modular credenza (60"D).
 - 30"W modular return attached to a 30"D single pedestal desk or modular desk (60"D).

48"W

- Spans full-width of 48"W return, modular return, or modular desk or credenza.
- Spans full-depth of the 48"D jetty peninsula or extended corner unit.

42"W

- Spans full-width of 42"W return, modular return, or modular desk or credenza.
- Spans full-depth of 42"D jetty peninsula.

36"W

- Spans full-width of 36"W modular return, modular desk or credenza, two drawer lateral file, or 29½"H storage cabinet with doors.
- Spans full-depth of 36"D desks with rectangle top, bullet peninsula, extended corner unit, or 36" corner unit.

OPTIONS INCLUDE:

- Door/Storage Options:

Door(s)	Standard-Height	Executive-Height
Laminate	•	•
Laminate Locking	•	•
Frosted/Silver	•	•
Sliding	•	•

- Available in 35¼" or 78⅛"H; when positioned on 29½"H base unit, heights respectively align with 64¾" and 78⅛"H storage- and wardrobe-type cabinets.
- Paper organizers for stack-on and wall mounted storage cabinets (see application and compatibility information on page 111).

CONCINNITY™ STACK-ON STORAGE APPLICATIONS

- Fabric-Covered :
 - Sized $\frac{3}{4}$ " narrower than the stack-on storage back enclosure, allowing $\frac{3}{8}$ " on each side to route task light cords.
 - Includes adhesive latch & hook tape for attachment to stack-on storage back panel and fasteners for wall mount applications.
 - For a list of standard fabrics, see pages 25-26. For a complete list of fabrics, please go to hon.com/fabricsandfinishes.
- :
 - HLSL1530SOMB: 29 $\frac{1}{2}$ "W x 12 $\frac{1}{2}$ "H panel attaches to 60" and 66"W stack-on and wall mounted storage with sliding door models with double-sided tape.
 - HLSL1536SOMB: 35 $\frac{1}{2}$ "W x 12 $\frac{1}{2}$ "H panel attaches to 72" and 78"W stack-on and wall mounted storage with sliding door models with double-sided tape.
- will not fit on stack-on storage laminate or laminate locking door models.
- Task Lights:
 - Attach to underside of stack-on and wall mount storage cabinets.
 - Fluorescent or LED options.
 - and fluorescent and LED task light solutions, by model, for each stack-on storage size:

Stack-on Storage		Fluorescent Task Light	LED Task Light
78"W	H90057	HH870960, HH870960CH	HLED31A, HLED31AUO
72"W	H90056	HH870960, HH870960CH	HLED31A, HLED31AUO
66"W	H90055	HH870960, HH870960CH	HLED31A, HLED17AUO
60"W	H90054	HH870960, HH870960CH	HLED31A, HLED17AUO
48"W	H90053	HH870942, HH870942CH	HLED31AS
42"W	H90052	HH870942, HH870942CH	HLED31AS
36"W	H90051	HH870930, HH870930CH	HLED17AS



Icon Legend on page 19

CONCINNITY™ Stack-on Storage

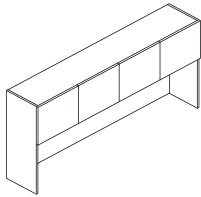

DESCRIPTION

Stack-on Storage, Laminate Doors

- 78"W x 15"D x 35¼"H — 4 doors, 2 compartments
- 72"W x 15"D x 35¼"H — 4 doors, 2 compartments
- 66"W x 15"D x 35¼"H — 4 doors, 2 compartments
- 60"W x 15"D x 35¼"H — 4 doors, 2 compartments
- 48"W x 15"D x 35¼"H — 3 doors, 2 compartments
- 42"W x 15"D x 35¼"H — 2 doors, 1 compartment
- 36"W x 15"D x 35¼"H — 2 doors, 1 compartment

MODEL	SHIP WEIGHT	CUBE	L1 LIST	L2 UPCHARGES	
				CHASSIS	FRONTS
HNL3678LD	173	31.8	\$1322	\$45	\$20
HNL3672LD	162	29.0	\$1267	\$35	\$20
HNL3666LD	151	26.7	\$1250	\$35	\$20
HNL3660LD	139	24.3	\$1140	\$35	\$20
HNL3648LD	117	19.6	\$1029	\$30	\$20
HNL3642LD	100	18.1	\$1003	\$30	\$10
HNL3636LD	88	15.3	\$848	\$30	\$10

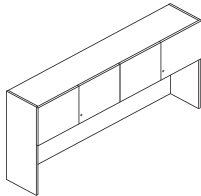

Stack-on Storage, Laminate Locking Doors

- 78"W x 15"D x 35¼"H — 4 doors, 2 compartments
- 72"W x 15"D x 35¼"H — 4 doors, 2 compartments
- 66"W x 15"D x 35¼"H — 4 doors, 2 compartments
- 60"W x 15"D x 35¼"H — 4 doors, 2 compartments
- 48"W x 15"D x 35¼"H — 3 doors, 2 compartments
- 42"W x 15"D x 35¼"H — 2 doors, 1 compartment
- 36"W x 15"D x 35¼"H — 2 doors, 1 compartment

HNL3678LL	173	31.8	\$1405	\$45	\$20
HNL3672LL	162	29.0	\$1350	\$35	\$20
HNL3666LL	151	26.7	\$1332	\$35	\$20
HNL3660LL	139	24.3	\$1223	\$35	\$20
HNL3648LL	117	19.6	\$1070	\$30	\$20
HNL3642LL	100	18.1	\$1044	\$30	\$10
HNL3636LL	88	15.3	\$889	\$30	\$10

ⓘ Lock available in Black (P) or Satin (SA) finish. Lock is core removable. Keyed alike cores must be ordered separately. For stack-on and wall mount storage with locking hinged doors, specify model HF27B (Black) or HF27S (Satin) and the key number, see page 112. Model HNL3648LL has one lock, which secures two of the three doors.

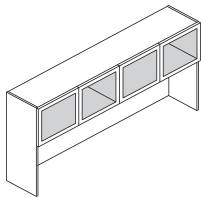

Stack-on Storage, Frosted Doors with Silver Frame

- 78"W x 15"D x 35¼"H — 4 doors, 2 compartments
- 72"W x 15"D x 35¼"H — 4 doors, 2 compartments
- 66"W x 15"D x 35¼"H — 4 doors, 2 compartments
- 60"W x 15"D x 35¼"H — 4 doors, 2 compartments
- 48"W x 15"D x 35¼"H — 3 doors, 2 compartments
- 42"W x 15"D x 35¼"H — 2 doors, 1 compartment
- 36"W x 15"D x 35¼"H — 2 doors, 1 compartment

HNL3678FD	153	31.8	\$1942	\$45	N/A
HNL3672FD	143	29.0	\$1887	\$35	N/A
HNL3666FD	134	26.7	\$1869	\$35	N/A
HNL3660FD	124	24.3	\$1760	\$35	N/A
HNL3648FD	104	19.6	\$1493	\$30	N/A
HNL3642FD	89	18.1	\$1313	\$30	N/A
HNL3636FD	79	15.3	\$1158	\$30	N/A

ⓘ Frosted/silver door units do not have a lock option.

NOTES:

- Convenient off-the-worksurface storage requires no additional floor space.
- 35¼"H stack-on storage models ship fully assembled.
- Fully enclosed back provides privacy; includes a 1¼", full-width pass-through for 3-prong electrical plugs; facilitates routing cords and reaching wall electrical outlets.
- Lower back panel can be attached with cord pass-through at bottom next to the worksurface or at top for close proximity to task light cord.
- Lower back panel can be removed to facilitate collaboration in teaming configurations.
- Valance hides task light.
- Vertical clearance for computer monitor is 20".
- Laminate vertical paper organizer (HLVPM1) sized to fit below storage compartments.
- Can be specified in seven widths (36", 42", 48", 60", 66", 72", and 78"W) and two heights, standard (35¼"H) or executive (48¾"H).
- Available with laminate doors, frosted/silver doors, or sliding door.
- Doors are sized to overlap the top, end panels and light valance, to provide a clean design.
- Laminate and frosted/silver door units are equipped with self-closing, adjustable hinges.
- Laminate hinged door units are available with or without a lock.
- For , see page 59.
- For task lights, see page 113.

For more information, see page 110.

HOW TO SPECIFY

<p>Select Model Number</p> <p>H N L 3 6 7 2 L D</p>	<p>Select Chassis Color</p> <p>See page 29</p> <p>H</p>	<p>Select Door Front Color</p> <p>See page 29</p> <p>H</p>	
<p>Select Model Number</p> <p>H N L 3 6 7 2 L L</p>	<p>Select Lock Finish</p> <p>See page 29</p> <p>P</p>	<p>Select Chassis Color</p> <p>See page 29</p> <p>H</p>	<p>Select Door Front Color</p> <p>See page 29</p> <p>H</p>
<p>Select Model Number</p> <p>H N L 3 6 7 2 F D</p>	<p>Select Chassis Color</p> <p>See page 29</p> <p>H</p>		

CONCINNITY™

Stack-on Storage

GSA SIN 33721

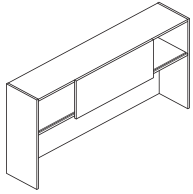

Icon Legend on page 19

**DESCRIPTION****Stack-on Storage, Sliding Door**

78"W x 15"D x 35¼"H
 72"W x 15"D x 35¼"H
 66"W x 15"D x 35¼"H
 60"W x 15"D x 35¼"H
 48"W x 15"D x 35¼"H

MODEL

HNL3678SD
HNL3672SD
HNL3666SD
HNL3660SD
HNL3648SD

SHIP WEIGHT

161
 151
 141
 131
 110

CUBE

31.8
 29.0
 26.7
 24.3
 19.6

L1 LIST

\$1267
\$1229
\$1133
\$1101
\$1041

L2 UPCHARGES

CHASSIS	FRONTS
\$45	\$20
\$35	\$20
\$35	\$20
\$35	\$20
\$30	\$20

NOTES: Sliding door units have one door per cabinet; standard with black lock, which is located on inside vertical support panel. Lock is core removable. Keyed alike cores must be ordered separately. For stack-on and wall mount storage with sliding door, specify model HF27B (Black) and the key number, see page 112. Sliding door availability limited to select sizes.

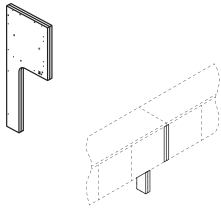
**Stack-on Space Saver End Panels**

¾"W x 14¼"D x 35¼"H

HNL3605SSEP

14

1.7

\$379**\$15****N/A**

NOTES: Two field installable end panels (1-right; 1-left) for use in ganging two stack-on storage units. Combining stack-on allows users to span longer worksurfaces, including 84" (2 - 42"W), 96" (2 - 48"W), 120" (2 - 60"W), and 144" (2 - 72"W). Narrow, space-saving panel size replaces the full 15"D end panels to expand worksurface space. The ¾" right end panel is to replace the standard 15"D right end panel on one stack-on storage unit, the ¾" left end panel is to replace the standard 15"D left end panel on a separate, adjacent stack-on storage unit that is in linear alignment with the first unit. Kit includes: (2) narrow end panel supports; European-style fasteners; dowels; joint connector bolts with sleeve nuts (for ganging stack-on storage units). Can be used to connect up to two stack-on storage units in a line (requires 1 kit). Can be specified in a woodgrain or solid laminate color only.

SPECIFYING EXAMPLE: HNL3605SSEP.H**NOTES:**

- Convenient off-the-worksurface storage requires no additional floor space.
- 35¼"H stack-on storage models ship fully assembled.
- Fully enclosed back provides privacy; includes a 1¼", full-width pass-through for 3-prong electrical plugs; facilitates routing cords and reaching wall electrical outlets.
- Lower back panel can be attached with cord pass-through at bottom next to the worksurface or at top for close proximity to task light cord.
- Lower back panel can be removed to facilitate collaboration in teaming configurations.
- Valance hides task light.
- Vertical clearance for computer monitor is 20".
- Laminate vertical paper organizer (HLVPM1) sized to fit below storage compartments.
- Can be specified in seven widths (36", 42", 48", 60", 66", 72", and 78"W) and two heights, standard (35¼"H) or executive (48¾"H).
- Available with laminate doors, frosted/silver doors, or sliding door.
- Doors are sized to overlap the top, end panels and light valance, to provide a clean design.
- Laminate and frosted/silver door units are equipped with self-closing, adjustable hinges.
- Laminate hinged door units are available with or without a lock.
- For , see page 59.
- For task lights, see page 113.
- For paper organizers, see page 110.

HOW TO SPECIFY**Select Model Number**

H N L 3 6 7 2 S D

Select Chassis Color

See page 29

H

Select Door Front Color

See page 29

H



CONCINNITY™ Stack-on Storage

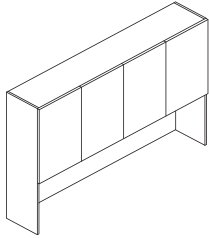

DESCRIPTION

Stack-on Storage, Laminate Doors
 78"W x 15"D x 48⁵/₈"H — 4 doors, 2 compartments
 72"W x 15"D x 48⁵/₈"H — 4 doors, 2 compartments
 66"W x 15"D x 48⁵/₈"H — 4 doors, 2 compartments
 60"W x 15"D x 48⁵/₈"H — 4 doors, 2 compartments
 48"W x 15"D x 48⁵/₈"H — 3 doors, 2 compartments
 42"W x 15"D x 48⁵/₈"H — 2 doors, 1 compartment
 36"W x 15"D x 48⁵/₈"H — 2 doors, 1 compartment

MODEL	SHIP WEIGHT	CUBE	L1 LIST	L2 UPCHARGES	
				CHASSIS	FRONTS
HNL4978LD	264	31.3	\$1784	\$60	\$20
HNL4972LD	243	29.1	\$1642	\$50	\$20
HNL4966LD	229	26.8	\$1551	\$50	\$20
HNL4960LD	212	24.5	\$1443	\$50	\$20
HNL4948LD	175	26.4	\$1376	\$45	\$20
HNL4942LD	149	23.2	\$1206	\$45	\$20
HNL4936LD	145	20.3	\$1167	\$45	\$20

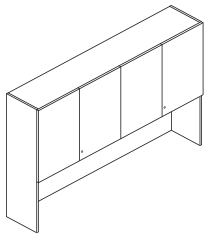

Stack-on Storage, Laminate Locking Doors
 78"W x 15"D x 48⁵/₈"H — 4 doors, 2 compartments
 72"W x 15"D x 48⁵/₈"H — 4 doors, 2 compartments
 66"W x 15"D x 48⁵/₈"H — 4 doors, 2 compartments
 60"W x 15"D x 48⁵/₈"H — 4 doors, 2 compartments
 48"W x 15"D x 48⁵/₈"H — 3 doors, 2 compartments
 42"W x 15"D x 48⁵/₈"H — 2 doors, 1 compartment
 36"W x 15"D x 48⁵/₈"H — 2 doors, 1 compartment

HNL4978LL	264	31.3	\$1866	\$60	\$20
HNL4972LL	243	29.1	\$1725	\$50	\$20
HNL4966LL	229	26.8	\$1634	\$50	\$20
HNL4960LL	212	24.5	\$1526	\$50	\$20
HNL4948LL	175	26.4	\$1417	\$45	\$20
HNL4942LL	149	23.2	\$1248	\$45	\$20
HNL4936LL	145	20.3	\$1209	\$45	\$20

! Lock available in Black (P) or Satin (SA) finish. Lock is core removable. Keyed alike cores must be ordered separately. For stack-on and wall mount storage with locking hinged doors, specify model HF27B (Black) or HF27S (Satin) and the key number, see page 112. Model HNL4948LL has one lock, which secures two of the three doors.

NOTES:

- Convenient off-the-worksurface storage requires no additional floor space.
- 48⁵/₈"H units have a fixed, intermittent shelf; storage space above and below the shelf is 12⁵/₈".
- Product applications are detailed on pages 53-54.
- Fully enclosed back provides privacy; includes a 1/4", full-width pass-through for 3-prong electrical plugs; facilitates routing cords and reaching wall electrical outlets.
- Lower back panel can be attached with cord pass-through at bottom next to the worksurface or at top for close proximity to task light cord.
- Lower back panel can be removed to facilitate collaboration in teaming configurations.
- Valance hides task light.
- Vertical clearance for computer monitor is 20".
- Laminate vertical paper organizer (HLVPM1) sized to fit below storage compartments.
- Can be specified in seven widths (36", 42", 48", 60", 66", 72", and 78"W) and two heights, standard (35¹/₄"H) or executive (48⁵/₈"H).
- Available with laminate doors, frosted/silver doors, or sliding door.
- Doors are sized to overlap the top, end panels and light valance, to provide a clean design.
- Laminate and frosted/silver door units are equipped with self-closing, adjustable hinges.
- Laminate hinged door units are available with or without a lock.
- For , see page 59.
- For task lights, see page 113.
- For paper organizers, see page 110.

HOW TO SPECIFY

<p>Select Model Number</p> <p>H N L 4 9 7 8 L D</p>	<p>Select Chassis Color</p> <p>See page 29</p> <p>H</p>	<p>Select Door Front Color</p> <p>See page 29</p> <p>H</p>	
<p>Select Model Number</p> <p>H N L 4 9 7 8 L L</p>	<p>Select Lock Finish</p> <p>See page 29</p> <p>P</p>	<p>Select Chassis Color</p> <p>See page 29</p> <p>H</p>	<p>Select Door Front Color</p> <p>See page 29</p> <p>H</p>

CONCINNITY™

Stack-on Storage

GSA SIN 33721

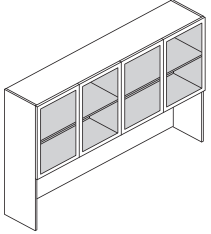

Icon Legend on page 19

**DESCRIPTION****Stack-on Storage, Frosted Doors with Silver Frame**

78"W x 15"D x 48 $\frac{5}{8}$ "H — 4 doors, 2 compartments
 72"W x 15"D x 48 $\frac{5}{8}$ "H — 4 doors, 2 compartments
 66"W x 15"D x 48 $\frac{5}{8}$ "H — 4 doors, 2 compartments
 60"W x 15"D x 48 $\frac{5}{8}$ "H — 4 doors, 2 compartments
 48"W x 15"D x 48 $\frac{5}{8}$ "H — 3 doors, 2 compartments
 42"W x 15"D x 48 $\frac{5}{8}$ "H — 2 doors, 1 compartment
 36"W x 15"D x 48 $\frac{5}{8}$ "H — 2 doors, 1 compartment

! Frosted/silver door units do not have a lock option.

MODEL**SHIP WEIGHT****CUBE****L1 LIST****L2 UPCHARGES****CHASSIS****FRONTS**

HNL4978FD	225	31.3	\$2713	\$60	N/A
HNL4972FD	207	29.1	\$2571	\$50	N/A
HNL4966FD	196	26.8	\$2481	\$50	N/A
HNL4960FD	182	24.5	\$2372	\$50	N/A
HNL4948FD	152	26.4	\$2073	\$45	N/A
HNL4942FD	128	23.2	\$1671	\$45	N/A
HNL4936FD	114	20.3	\$1632	\$45	N/A

NOTES:

- Convenient off-the-worksurface storage requires no additional floor space.
- 48 $\frac{5}{8}$ "H units have a fixed, intermittent shelf; storage space above and below the shelf is 12 $\frac{5}{8}$ ".
- Product applications are detailed on pages 53-54.
- Fully enclosed back provides privacy; includes a 1 $\frac{1}{4}$ " , full-width pass-through for 3-prong electrical plugs; facilitates routing cords and reaching wall electrical outlets.
- Lower back panel can be attached with cord pass-through at bottom next to the worksurface or at top for close proximity to task light cord.
- Lower back panel can be removed to facilitate collaboration in teaming configurations.
- Valance hides task light.
- Vertical clearance for computer monitor is 20".
- Laminate vertical paper organizer (HLVPM1) sized to fit below storage compartments.
- Can be specified in seven widths (36", 42", 48", 60", 66", 72", and 78"W) and two heights, standard (35 $\frac{1}{4}$ "H) or executive (48 $\frac{5}{8}$ "H).
- Available with laminate doors, frosted/silver doors, or sliding door.
- Doors are sized to overlap the top, end panels and light valance, to provide a clean design.
- Laminate and frosted/silver door units are equipped with self-closing, adjustable hinges.
- Laminate hinged door units are available with or without a lock.
- For , see page 59.
- For task lights, see page 113.
- For paper organizers, see page 110.

HOW TO SPECIFY

Select
Model Number

H N L 4 9 7 8 F D .

Select
Chassis Color

See page 29

H



CONCINNITY™ Stack-on Storage

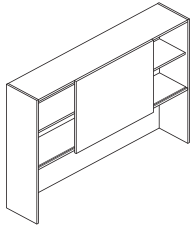

DESCRIPTION	MODEL	COM	SHIP WEIGHT	CUBE	L1 LIST	L2 UPCHARGES	
						CHASSIS	FRONTS
Stack-on Storage, Sliding Door							
78"W x 15"D x 48 ⁵ / ₈ "H	HNL4978SD		236	31.3	\$1809	\$60	\$20
72"W x 15"D x 48 ⁵ / ₈ "H	HNL4972SD		221	29.1	\$1712	\$50	\$20
66"W x 15"D x 48 ⁵ / ₈ "H	HNL4966SD		207	26.8	\$1674	\$50	\$20
60"W x 15"D x 48 ⁵ / ₈ "H	HNL4960SD		192	24.5	\$1475	\$50	\$20
48"W x 15"D x 48 ⁵ / ₈ "H	HNL4948SD		162	26.4	\$1405	\$45	\$20

NOTES: Sliding door units have one door per cabinet; standard with black lock, which is located on inside vertical support panel. Lock is core removable. Keyed alike cores must be ordered separately. For stack-on and wall mount storage with sliding door, specify model HF27B (Black) and the key number, see page 112. Sliding door availability limited to select sizes.

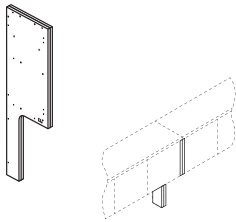

DESCRIPTION	MODEL	COM	SHIP WEIGHT	CUBE	L1 LIST	L2 UPCHARGES
Stack-on Space Saver End Panels 3/4"W x 14 1/4"D x 48 5/8"H	HNL4905SSEP		23	2.2	\$513	\$15 N/A

NOTES: Two field installable end panels (1-right; 1-left) for use in ganging two stack-on storage units. Combining stack-on allows users to span longer worksurfaces, including 84" (2 - 42"W), 96" (2 - 48"W), 120" (2 - 60"W), and 144" (2 - 72"W). Narrow, space-saving panel size replaces the full 15"D end panels to expand worksurface space. The 4 1/4" right end panel is to replace the standard 15"D right end panel on one stack-on storage unit, the 4 1/4" left end panel is to replace the standard 15"D left end panel on a separate, adjacent stack-on storage unit that is in linear alignment with the first unit. Kit includes: (2) narrow end panel supports; European-style fasteners; dowels; joint connector bolts with sleeve nuts (for ganging stack-on storage units). Can be used to connect up to two stack-on storage units in a line (requires 1 kit). Can be specified in a woodgrain or solid laminate color only.

SPECIFYING EXAMPLE: HNL4905SSEP.H

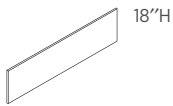

DESCRIPTION	MODEL	COM	SHIP WEIGHT	CUBE	L1 LIST	L2 UPCHARGES
for use with Stack-on Storage 75"W - for						
78"W	H90057	3.0	13	3.2	\$317	N/A N/A
68 3/4"W - for 72"W	H90056	2.0	12	2.7	\$301	N/A N/A
62 3/4"W - for 66"W	H90055	2.0	11	2.5	\$286	N/A N/A
56 3/4"W - for 60"W	H90054	2.0	10	2.2	\$252	N/A N/A
44 3/4"W - for 48"W	H90053	2.0	8	1.8	\$242	N/A N/A
39"W - for 42"W	H90052	2.0	7	1.6	\$223	N/A N/A
33"W - for 36"W	H90051	1.0	6	1.4	\$196	N/A N/A
26 3/4"W	H90050	1.0	5	1.2	\$196	N/A N/A

NOTES: Specify fabric, see pages 25-26. Upcharges may apply to premium fabric grades.

Disperse (DISP) fabric not available on sizes wider than 60". Analog (ANLG) and Exchange (EXG) not available on sizes wider than 72".

SPECIFYING EXAMPLE: H90057.APN15

NOTES:

- Convenient off-the-worksurface storage requires no additional floor space.
- 48 5/8"H units have a fixed, intermittent shelf; storage space above and below the shelf is 12 5/8".
- Fully enclosed back provides privacy; includes a 1/4", full-width pass-through for 3-prong electrical plugs; facilitates routing cords and reaching wall electrical outlets.
- Lower back panel can be attached with cord pass-through at bottom next to the worksurface or at top for close proximity to task light cord.
- Lower back panel can be removed to facilitate collaboration in teaming configurations.
- Valance hides task light.
- Vertical clearance for computer monitor is 20".
- Laminate vertical paper organizer (HLVPM1) sized to fit below storage compartments.
- Can be specified in seven widths (36", 42", 48", 60", 66", 72", and 78"W) and two heights, standard (35 1/4"H) or executive (48 5/8"H).
- Available with laminate doors, frosted/silver doors, or sliding door.
- Doors are sized to overlap the top, end panels and light valance, to provide a clean design.
- Laminate and frosted/silver door units are equipped with self-closing, adjustable hinges.
- Laminate hinged door units are available with or without a lock.
- For , see above.
- For task lights, see page 113.
- For paper organizers, see page 110.

HOW TO SPECIFY

<p>Select Model Number</p> <p>H N L 4 9 7 8 S D</p>	<p>Select Chassis Color</p> <p>See page 29</p> <p>H</p>	<p>Select Door Front Color</p> <p>See page 29</p> <p>H</p>
--	--	---

CONCINNITY™ WALL MOUNT STORAGE APPLICATIONS

- Installation (review carefully):
 - **Attachment requires individual cabinets be secured by a minimum of two (2) wall mounting locations/studs.**
 - **Designed for interior and perimeter walls that are constructed with wood or metal studs.**
 - **Attaches to wall with horizontally mounted, interlocking brackets.**
 - **The HON Company is not responsible for any liabilities resulting from wall mounted storage cabinets that are not properly installed.**
- Laminate, laminate locking, and frosted/silver door units can be specified in eight widths (30", 36", 42", 48", 60", 66", 72", and 78"W) and two heights, standard (15"H) or executive (29½"H).
- Sliding door units can be specified in five widths (48", 60", 66", 72", and 78"W) and two heights, standard (15"H) or executive (29½"H).
- Product placement can be aligned to match the height of 64¾"H or 78⅛"H storage- and wardrobe-type cabinets.
- Available with laminate doors, frosted/silver doors, or sliding door.
 - Door design overlaps end panels so that when multiple units are placed side-by-side they appear as one continuous unit.
 - Laminate and frosted/silver door units are equipped with self-closing, adjustable hinges.
 - Laminate hinged door units are available with or without a lock.
 - Lock available in Black (P) or Satin (SA).
 - Lock is core removable; keyed alike cores must be ordered separately — for overhead storage with hinged doors specify model HF27B or HF27S and the key number.
 - Frosted/silver hinged door units do not have a lock option.
 - Sliding door units have one door per cabinet; standard with black lock, which is located on inside vertical support panel. Lock is core removable; keyed alike cores must be ordered separately — for overhead storage with a sliding door specify model HF23B (Black) and the key number.
 - Laminate and frosted/silver door cabinets in 30", 36", and 42"W have two doors; 48"W has three doors; 60", 66", 72", and 78"W have four doors.
- Inside storage dimensions of 15"H cabinets:
 - 30"W = one compartment, sized 28⅜"W x 13⅜"D x 12¾"H
 - 36"W = one compartment, sized 34⅜"W x 13⅜"D x 12¾"H
 - 42"W = one compartment, sized 40⅜"W x 13⅜"D x 12¾"H
 - 48"W = two compartments, one sized 30⅝"W x 13⅜"D x 12¾"H; one sized 14⅝"W x 13⅜"D x 12¾"H
 - 60"W = two compartments, each 28⅝"W x 13⅜"D x 12¾"H
 - 66"W = two compartments, each 31⅝"W x 13⅜"D x 12¾"H
 - 72"W = two compartments, each 34⅝"W x 13⅜"D x 12¾"H
 - 78"W = two compartments, each 37⅝"W x 13⅜"D x 12¾"H
- 28½"H units have a fixed, intermittent shelf; storage space above and below the shelf is 12⅝".
- Wall mounted storage cabinets are not designed for attachment to O-leg models HLSL65OS or HLSL50OS.
- Horizontal interlocking rails are included; due to varying types of walls, installers are responsible for selecting and supplying the appropriate fasteners.
- Ship fully assembled.

CONCINNITY™ WALL MOUNT STORAGE APPLICATIONS

OPTIONS INCLUDE:

- Door/Storage Options:

Door(s)	Standard-Height	Executive-Height
Laminate	•	•
Laminate Locking	•	•
Frosted/Silver	•	•
Sliding	48"-78"W only	48"-78"W only

- Paper organizers for stack-on and wall mounted storage cabinets (see compatibility information on page 111).
- Fabric-Covered :
 - mount directly to wall using the fasteners or hook-and-loop tape provided.
 - For a list of standard fabrics, see pages 25-26. For a complete list of fabrics, please go to hon.com/fabricsandfinishes.
 - See compatibility cross reference below.
 - NOTE: widths differ slightly from the wall mounted storage cabinet widths. For applications where multiple wall mounted storage units are placed side-by-side, the preferred solution may be to utilize a larger size. For example, H90057 = 75"W; H90056 = 68¾"W; H90055 = 62¾"W; H90054 = 56¾"W.
- :
 - HL1530SOMB: 29½"W x 12½"H panel attaches to 60" and 66"W stack-on and wall mounted storage with sliding door models with double-sided tape.
 - HL1536SOMB: 35½"W x 12½"H panel attaches to 72" and 78"W stack-on and wall mounted storage with sliding door models with double-sided tape.
- Task Lights:
 - Attach to underside of stack-on and wall mount storage cabinets.
 - Fluorescent or LED options.
 - Compatibility: and task light solutions, by model, for each wall mounted storage cabinet size:

Wall Mounted Storage		Fluorescent Task Light	LED Task Light
78"W	H90057 (75"W) or qty 2 of H90052 (39"W ea.)	HH870960, HH870960CH	HLED31A, HLED31AUO
72"W	H90056 (71½"W)	HH870960, HH870960CH	HLED31A, HLED31AUO
66"W	H90055 (65½"W)	HH870960, HH870960CH	HLED31A, HLED17AUO
60"W	H90054 (59½"W)	HH870960, HH870960CH	HLED31A, HLED17AUO
48"W	H90053 (44¾"W)	HH870942, HH870942CH	HLED31AS
42"W	H90052 (39"W)	HH870942, HH870942CH	HLED31AS
36"W	H90051 (33"W)	HH870930, HH870930CH	HLED17AS
30"W	H90050 (26¾"W)	HH870930, HH870930CH	HLED17AS

CONCINNITY™

Wall Mount Storage

GSA SIN 33721

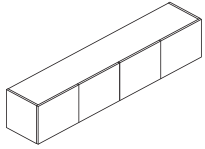

Icon Legend on page 19

**DESCRIPTION****Wall Mount Storage, Laminate Doors**

78"W x 15"D x 15"H — 4 doors, 2 compartments
 72"W x 15"D x 15"H — 4 doors, 2 compartments
 66"W x 15"D x 15"H — 4 doors, 2 compartments
 60"W x 15"D x 15"H — 4 doors, 2 compartments
 48"W x 15"D x 15"H — 3 doors, 2 compartments
 42"W x 15"D x 15"H — 2 doors, 1 compartment
 36"W x 15"D x 15"H — 2 doors, 1 compartment
 30"W x 15"D x 15"H — 2 doors, 1 compartment

MODEL**SHIP WEIGHT****CUBE****L1 LIST****L2 UPCHARGES**
CHASSIS FRONTS

HNL1578LD	126	17.1	\$1245	\$35	\$20
HNL1572LD	118	15.9	\$1156	\$25	\$20
HNL1566LD	109	14.6	\$1101	\$25	\$20
HNL1560LD	100	13.3	\$989	\$25	\$20
HNL1548LD	83	10.9	\$892	\$20	\$20
HNL1542LD	68	9.7	\$842	\$20	\$10
HNL1536LD	60	8.4	\$770	\$20	\$10
HNL1530LD	51	7.2	\$711	\$20	\$10

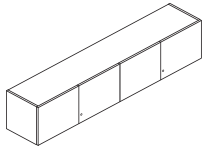
**Wall Mount Storage, Laminate Locking Doors**

78"W x 15"D x 15"H — 4 doors, 2 compartments
 72"W x 15"D x 15"H — 4 doors, 2 compartments
 66"W x 15"D x 15"H — 4 doors, 2 compartments
 60"W x 15"D x 15"H — 4 doors, 2 compartments
 48"W x 15"D x 15"H — 3 doors, 2 compartments
 42"W x 15"D x 15"H — 2 doors, 1 compartment
 36"W x 15"D x 15"H — 2 doors, 1 compartment
 30"W x 15"D x 15"H — 2 doors, 1 compartment

HNL1578LL	126	17.1	\$1327	\$35	\$20
HNL1572LL	118	15.9	\$1238	\$25	\$20
HNL1566LL	109	14.6	\$1184	\$25	\$20
HNL1560LL	100	13.3	\$1071	\$25	\$20
HNL1548LL	83	10.9	\$933	\$20	\$20
HNL1542LL	68	9.7	\$883	\$20	\$10
HNL1536LL	60	8.4	\$811	\$20	\$10
HNL1530LL	51	7.2	\$752	\$20	\$10

! Lock available in Black (P) or Satin (SA) finish. Lock is core removable. Keyed alike cores must be ordered separately. For stack-on and wall mount storage with locking hinged doors, specify model HF27B (Black) or HF27S (Satin) and the key number, see page 112. Model HNL1548LL has one lock, which secures two of the three doors.

NOTES:

- Convenient off-the-worksurface storage requires no additional floor space.
- Available with laminate doors, frosted/silver doors, or sliding door.
- Doors are sized to overlap the top, end panels and light valance, to provide a clean design.
- Laminate and frosted/silver door units are equipped with self-closing, adjustable hinges.
- Laminate hinged door units are available with or without a lock.
- For , see page 65.
- For task lights, see page 113.
- For paper organizers, see page 110.
- **IMPORTANT: See installation guidelines at top of page 60.**

HOW TO SPECIFY**Select Model Number**

H N L 1 5 7 8 L D

Select Chassis Color

See page 29

H

Select Door Front Color

See page 29

H

Select Model Number

H N L 1 5 7 8 L L

Select Lock Finish

See page 29

P

Select Chassis Color

See page 29

H

Select Door Front Color

See page 29

H



CONCINNITY™ Wall Mount Storage

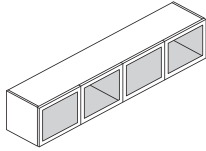

DESCRIPTION

Wall Mount Storage, Frosted Doors with Silver Frame

- 78"W x 15"D x 15"H — 4 doors, 2 compartments
- 72"W x 15"D x 15"H — 4 doors, 2 compartments
- 66"W x 15"D x 15"H — 4 doors, 2 compartments
- 60"W x 15"D x 15"H — 4 doors, 2 compartments
- 48"W x 15"D x 15"H — 3 doors, 2 compartments
- 42"W x 15"D x 15"H — 2 doors, 1 compartment
- 36"W x 15"D x 15"H — 2 doors, 1 compartment
- 30"W x 15"D x 15"H — 2 doors, 1 compartment

MODEL

SHIP WEIGHT

CUBE

L1 LIST

L2 UPCHARGES
CHASSIS FRONTS

HNL1578FD	106	17.1	\$1864	\$35	N/A
HNL1572FD	99	15.9	\$1775	\$25	N/A
HNL1566FD	92	14.6	\$1721	\$25	N/A
HNL1560FD	85	13.3	\$1608	\$25	N/A
HNL1548FD	71	10.9	\$1356	\$20	N/A
HNL1542FD	57	9.7	\$1152	\$20	N/A
HNL1536FD	50	8.4	\$1079	\$20	N/A
HNL1530FD	43	7.2	\$1021	\$20	N/A

❗ Frosted door models do not have a lock option.

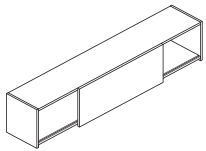

Wall Mount Storage, Sliding Door

- 78"W x 15"D x 15"H
- 72"W x 15"D x 15"H
- 66"W x 15"D x 15"H
- 60"W x 15"D x 15"H
- 48"W x 15"D x 15"H

HNL1578SD	114	17.1	\$1212	\$35	\$20
HNL1572SD	107	15.9	\$1113	\$25	\$20
HNL1566SD	99	14.6	\$1036	\$25	\$20
HNL1560SD	91	13.3	\$941	\$25	\$20
HNL1548SD	76	10.9	\$881	\$20	\$20

NOTES: One door per unit. Standard with black lock, which is located on the inside vertical support panel. Lock is core removable. Keyed alike cores must be ordered separately. For stack-on and wall mount storage with sliding door, specify model HF23B (Black) and the key number, see page 112.

NOTES:

- Convenient off-the-worksurface storage requires no additional floor space.
- Available with laminate doors, frosted/silver doors, or sliding door.
- Doors are sized to overlap the top, end panels and light valance, to provide a clean design.
- Laminate and frosted/silver door units are equipped with self-closing, adjustable hinges.
- Laminate hinged door units are available with or without a lock.
- For , see page 65.
- For task lights, see page 113.
- For paper organizers, see page 110.
- **IMPORTANT: See installation guidelines at top of page 60.**

HOW TO SPECIFY

<p>Select Model Number</p> <div style="border: 1px solid black; display: flex; justify-content: space-between; padding: 2px;"> HNL1578FD </div>	<p>Select Chassis Color</p> <p>See page 29</p> <div style="border: 1px solid black; display: flex; justify-content: space-between; padding: 2px;"> H </div>	
<p>Select Model Number</p> <div style="border: 1px solid black; display: flex; justify-content: space-between; padding: 2px;"> HNL1578SD </div>	<p>Select Chassis Color</p> <p>See page 29</p> <div style="border: 1px solid black; display: flex; justify-content: space-between; padding: 2px;"> H </div>	<p>Select Door Front Color</p> <p>See page 29</p> <div style="border: 1px solid black; display: flex; justify-content: space-between; padding: 2px;"> H </div>

CONCINNITY™

Wall Mount Storage

GSA SIN 33721

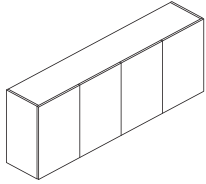

Icon Legend on page 19

**DESCRIPTION****Wall Mount Storage, Laminate Doors**

78"W x 15"D x 28½"H — 4 doors, 2 compartments
 72"W x 15"D x 28½"H — 4 doors, 2 compartments
 66"W x 15"D x 28½"H — 4 doors, 2 compartments
 60"W x 15"D x 28½"H — 4 doors, 2 compartments
 48"W x 15"D x 28½"H — 3 doors, 2 compartments
 42"W x 15"D x 28½"H — 2 doors, 1 compartment
 36"W x 15"D x 28½"H — 2 doors, 1 compartment
 30"W x 15"D x 28½"H — 2 doors, 1 compartment

MODEL**SHIP WEIGHT****CUBE****L1 LIST****L2 UPCHARGES**
CHASSIS FRONTS

HNL2978LD	213	30.8	\$1509	\$50	\$40
HNL2972LD	199	28.6	\$1432	\$40	\$40
HNL2966LD	185	26.4	\$1387	\$40	\$40
HNL2960LD	170	24.1	\$1288	\$40	\$40
HNL2948LD	142	19.7	\$1173	\$35	\$30
HNL2942LD	116	17.4	\$964	\$35	\$20
HNL2936LD	101	15.2	\$918	\$35	\$20
HNL2930LD	87	12.9	\$819	\$35	\$20

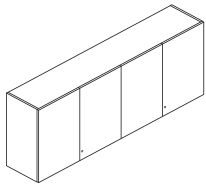
**Wall Mount Storage, Laminate Locking Doors**

78"W x 15"D x 28½"H — 4 doors, 2 compartments
 72"W x 15"D x 28½"H — 4 doors, 2 compartments
 66"W x 15"D x 28½"H — 4 doors, 2 compartments
 60"W x 15"D x 28½"H — 4 doors, 2 compartments
 48"W x 15"D x 28½"H — 3 doors, 2 compartments
 42"W x 15"D x 28½"H — 2 doors, 1 compartment
 36"W x 15"D x 28½"H — 2 doors, 1 compartment
 30"W x 15"D x 28½"H — 2 doors, 1 compartment

HNL2978LL	213	30.8	\$1592	\$50	\$40
HNL2972LL	199	28.6	\$1514	\$40	\$40
HNL2966LL	185	26.4	\$1470	\$40	\$40
HNL2960LL	170	24.1	\$1371	\$40	\$40
HNL2948LL	142	19.7	\$1215	\$35	\$30
HNL2942LL	116	17.4	\$1005	\$35	\$20
HNL2936LL	101	15.2	\$960	\$35	\$20
HNL2930LL	87	12.9	\$861	\$35	\$20

! Lock available in Black (P) or Satin (SA) finish. Lock is core removable. Keyed alike cores must be ordered separately. For stack-on and wall mount storage with locking hinged doors, specify model HF27B (Black) or HF27S (Satin) and the key number, see page 112. Model HNL2948LL has one lock, which secures two of the three doors.

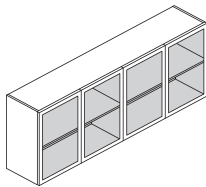
**Wall Mount Storage, Frosted Doors with Silver Frame**

78"W x 15"D x 28½"H — 4 doors, 2 compartments
 72"W x 15"D x 28½"H — 4 doors, 2 compartments
 66"W x 15"D x 28½"H — 4 doors, 2 compartments
 60"W x 15"D x 28½"H — 4 doors, 2 compartments
 48"W x 15"D x 28½"H — 3 doors, 2 compartments
 42"W x 15"D x 28½"H — 2 doors, 1 compartment
 36"W x 15"D x 28½"H — 2 doors, 1 compartment
 30"W x 15"D x 28½"H — 2 doors, 1 compartment

HNL2978FD	174	30.8	\$2438	\$50	N/A
HNL2972FD	163	28.6	\$2361	\$40	N/A
HNL2966FD	152	26.4	\$2316	\$40	N/A
HNL2960FD	140	24.1	\$2217	\$40	N/A
HNL2948FD	118	19.7	\$1870	\$35	N/A
HNL2942FD	94	17.4	\$1428	\$35	N/A
HNL2936FD	83	15.2	\$1383	\$35	N/A
HNL2930FD	72	12.9	\$1284	\$35	N/A

! Frosted door models do not have a lock option.

NOTES:

- Convenient off-the-worksurface storage requires no additional floor space.
- Available with laminate doors, frosted/silver doors, or sliding door.
- Doors are sized to overlap the top, end panels and light valance, to provide a clean design.
- Laminate and frosted/silver door units are equipped with self-closing, adjustable hinges.
- Laminate hinged door units are available with or without a lock.
- 28½"H units have a fixed, intermittent shelf; storage space above and below the shelf is 12¾".
- For , see page 65.
- For task lights, see page 113.
- For paper organizers, see page 110.
- **IMPORTANT: See installation guidelines at top of page 60.**

HOW TO SPECIFY**Select Model Number**

H N L 2 9 7 8 L D

Select Chassis Color

See page 29

H

Select Door Front Color

See page 29

H

Select Model Number

H N L 2 9 7 8 L L

Select Lock Finish

See page 29

P

Select Chassis Color

See page 29

H

Select Door Front Color

See page 29

H

Select Model Number

H N L 2 9 7 8 F D

Select Chassis Color

See page 29

H



CONCINNITY™ Wall Mount Storage

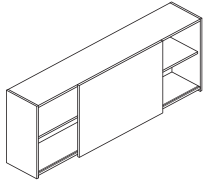

DESCRIPTION	MODEL	COM	SHIP WEIGHT	CUBE	L1 LIST	L2 UPCHARGES	
						CHASSIS	FRONTS
Wall Mount Storage, Sliding Door							
78"W x 15"D x 28½"H	HNL2978SD		189	30.8	\$1569	\$50	\$40
72"W x 15"D x 28½"H	HNL2972SD		177	28.6	\$1498	\$40	\$40
66"W x 15"D x 28½"H	HNL2966SD		165	26.4	\$1463	\$40	\$40
60"W x 15"D x 28½"H	HNL2960SD		153	24.1	\$1369	\$40	\$40
48"W x 15"D x 28½"H	HNL2948SD		129	19.7	\$1200	\$35	\$30

NOTES: One door per unit. Standard with black lock, which is located on the inside vertical support panel. Lock is core removable. Keyed alike cores must be ordered separately. For stack-on and wall mount storage with sliding door, specify model HF23B (Black) and the key number, see page 112.

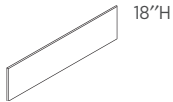

for use with Wall Mount Storage 75"W - for

78"W	H90057	3.0	13	3.2	\$317	N/A	N/A
68¾"W - for 72"W	H90056	2.0	12	2.7	\$301	N/A	N/A
62¾"W - for 66"W	H90055	2.0	11	2.5	\$286	N/A	N/A
56¾"W - for 60"W	H90054	2.0	10	2.2	\$252	N/A	N/A
44¾"W - for 48"W	H90053	2.0	8	1.8	\$242	N/A	N/A
39"W - for 42"W	H90052	2.0	7	1.6	\$223	N/A	N/A
33"W - for 36"W	H90051	1.0	6	1.4	\$196	N/A	N/A
26¾"W	H90050	1.0	5	1.2	\$196	N/A	N/A

NOTES: Specify fabric, see pages 25-26. Upcharges may apply to premium fabric grades.

widths differ slightly from the wall mounted storage cabinet widths. For applications where multiple wall mounted storage units are placed side-by-side, the preferred solution may be to utilize a larger size. For example, H90057 = 75"W; H90056 = 68¾"W; H90055 = 62¾"W; H90054 = 56¾"W.

⚠ Disperse (DISP) fabric not available on sizes wider than 60". Analog (ANLG) and Exchange (EXG) not available on sizes wider than 72".
SPECIFYING EXAMPLE: H90057.APN15

NOTES:

- Convenient off-the-worksurface storage requires no additional floor space.
- Valance hides task light.
- Available with laminate doors, frosted/silver doors, or sliding door.
- Doors are sized to overlap the top, end panels and light valance, to provide a clean design.
- Laminate and frosted/silver door units are equipped with self-closing, adjustable hinges.
- Laminate hinged door units are available with or without a lock.
- 28½"H units have a fixed, intermittent shelf; storage space above and below the shelf is 12½" .
- For , see above.
- For task lights, see page 113.
- For paper organizers, see page 110.
- **IMPORTANT: See installation guidelines at top of page 60.**

HOW TO SPECIFY

<p>Select Model Number</p> <p>H N L 2 9 7 8 S D</p>	<p>Select Chassis Color</p> <p>See page 29</p> <p>H</p>	<p>Select Door Front Color</p> <p>See page 29</p> <p>H</p>
--	--	---

CONCINNITY™

Bookcase Hutches

GSA SIN 33721

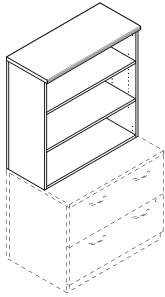

Icon Legend on page 19

**DESCRIPTION****Bookcase Hutch, No Doors/Open**

36"W x 14 1/4"D x 35 1/4"H (shown)
30"W x 14 1/4"D x 35 1/4"H

36"W x 14 1/4"D x 48 5/8"H
30"W x 14 1/4"D x 48 5/8"H

MODEL**SHIP WEIGHT****CUBE****L1 LIST****L2 UPCHARGES**
CHASSIS FRONTS

HNL3636BHxD
HNL3630BHxD

213
199

15.3
12.5

\$584
\$570

\$15
\$15

N/A
N/A

HNL4936BHxD
HNL4930BHxD

213
199

125.0
109.0

\$738
\$689

\$25
\$25

N/A
N/A

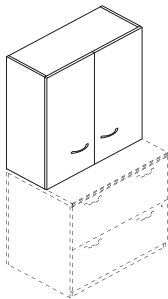
**Bookcase Hutch, Laminate Doors**

36"W x 15"D x 35 1/4"H (shown)
30"W x 15"D x 35 1/4"H

36"W x 15"D x 48 5/8"H
30"W x 15"D x 48 5/8"H

HNL3636BHLD
HNL3630BHLD

213
199

15.3
12.5

\$755
\$709

\$15
\$15

\$20
\$20

HNL4936BHLD
HNL4930BHLD

213
199

165.0
142.0

\$904
\$848

\$25
\$25

\$30
\$30

NOTES:

- Designed for use on worksurfaces, or on 30" or 36" W x 29 1/2" H lateral file or storage cabinet with doors.
- Two widths, 30" and 36"; two heights, 35 1/4" and 48 5/8".
- The 35 1/4" H unit has three shelves, two are adjustable in 1/4" increments with a total range of 17 1/2"; bottom shelf is fixed.
- The 48 5/8" H unit has four shelves, three are adjustable in 1/4" increments with a total range of 25"; bottom shelf is fixed.
- Available with laminate doors or frosted/silver doors or no doors (open).
- Door units equipped with self-closing, adjustable hinges.
- Laminate doors have decorative handles.
- Frosted door units have push/touch latch release.
- Doors are non-locking.
- To align with the top of the 35 1/4" bookcase hutch, use 64 3/4" H floor-standing storage models; to align with the top of the 48 5/8" H bookcase hutch, use 78 1/8" H models.
- Ship fully assembled.

HOW TO SPECIFY**Select Model Number**

H N L 3 6 3 6 B H X D .

Select Laminate Color

See page 29

H

Select Model Number

H N L 3 6 3 6 B H L D .

Select Handle

- A Cylinder - Satin
- B Cylinder - Black
- C Canopy - Satin
- D Canopy - Black
- E Loop - Satin
- F Loop - Black

E .

Select Chassis Color

See page 29

H .

Select Door Front Color

See page 29

H



CONCINNITY™ Bookcase Hutches

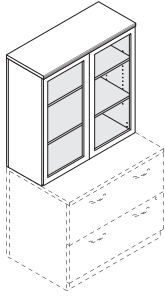

DESCRIPTION	MODEL	SHIP WEIGHT	CUBE	L1 LIST	L2 UPCHARGES	
					CHASSIS	FRONTS
Bookcase Hutch, Frosted Doors with Silver Frame 36"W x 15"D x 35¼"H (shown)	HNL3636BHFD	199	15.3	\$1375	\$15	N/A
36"W x 15"D x 48⅝"H	HNL4936BHFD	213	134.0	\$1678	\$25	N/A

NOTES:

- Designed for use on worksurfaces, or on 30" or 36"W x 29½"H lateral file or storage cabinet with doors.
- Two widths, 30" and 36"; two heights, 35¼" and 48⅝".
- The 35¼"H unit has three shelves, two are adjustable in 1¼" increments with a total range of 17½"; bottom shelf is fixed.
- The 48⅝"H unit has four shelves, three are adjustable in 1¼" increments with a total range of 25"; bottom shelf is fixed.
- Available with laminate doors or frosted/silver doors or no doors (open).
- Door units equipped with self-closing, adjustable hinges.
- Laminate doors have decorative handles.
- Frosted door units have push/touch latch release.
- Doors are non-locking.
- To align with the top of the 35¼"H bookcase hutch, use 64¾"H floor-standing storage models; to align with the top of the 48⅝"H bookcase hutch, use 78⅞"H models.
- Ship fully assembled.

HOW TO SPECIFY

<p>Select Model Number</p> <p>H N L 3 6 3 6 B H F D .</p>	<p>Select Chassis Color</p> <p>See page 29</p> <p>H</p>
--	--

CONCINNITY™

Reception Stations

GSA SIN 33721



Icon Legend on page 19

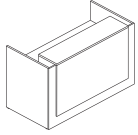

DESCRIPTION	MODEL	SHIP WEIGHT	CUBE	L1 LIST	L2 UPCHARGES		ACCENT PANEL
					WORKSURFACE	CHASSIS	

Reception Desk with Transaction Counter72"W x 36³/₄"D x 44"H**HLAM3772RD**

324

13.5

\$1474**\$35****\$70****\$25**

NOTES: Non-handed. Counter measures 60"W x 15¹/₄"D. Flat edge (G) matches 10500 Series™. For beaded (B) and tri-oval (V) edge shapes, the transaction counter is profiled on the approach and user sides, and the desk worksurface is profiled on the user's side. Beaded (B) and tri-oval (V) edges are available in L1 woodgrains colors only. Smooth and flat (G) edge available in all woodgrains and solid colors. Vertical grain on approach side and front accent panel for L1 laminates except Kingswood Walnut and Florence Walnut. Horizontal grain on L2 laminates and Kingswood and Florence Walnut. Vertical grain on end panels and horizontal grain on worksurface and transaction counter. Two worksurface cord management grommets for routing and hiding wires and cables; can be specified in Black (P) or Platinum (TI) finish.

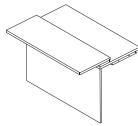
**Reception Return with 32'H Transaction Counter**48¹/₄"W x 32⁷/₈"D x 32"H**HLAM3348RR**

145

3.7

\$829**\$35****\$35****N/A**

NOTES: Non-handed. For use with HLAM3772RD and Reception Desk Shell (H105724). Counter facilitates accessibility; measures 48"W x 12"D x 32"H. Flat edge (G) matches 10500 Series™. For beaded (B) and tri-oval (V) edge shapes, the transaction counter is profiled on the approach side, and the return worksurface is profiled on the user's side. All other edges are flat banded. Beaded (B) and tri-oval (V) available in L1 woodgrain colors only. Flat edge (G) available in all woodgrains and solid colors. Pattern laminates do not have matching edge color; patterns can be specified with woodgrain or solid edge. Vertical grain on approach side, end panel, worksurface, and transaction counter. Assembly required.

Specify: Model.Edge Profile & EdgeColor.Worksurface & Counter Color.Chassis Color

SPECIFYING EXAMPLE: HLAM3348RR.GN.N.N**HOW TO SPECIFY**

Select Model Number

H L A M 3 7 7 2 R D .

Select Edge Profile and Edge Color

See page 29

G N .

Select Grommet Color

P Black
TI Platinum
Not specified for model HLAM3348RR

P .

Select Worksurface Laminate

See page 29

N .

Select Chassis Laminate

See page 29

N .

Select Accent Panel Laminate

See page 29
Not specified for model HLAM3348RR

L D W 1



Icon Legend on page 19

CONCINNITY™ Reception Stations

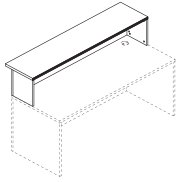

DESCRIPTION

Reception Station Counter for Desk
72"W x 17"D x 14 5/8"H

MODEL	SHIP WEIGHT	CUBE	L1 LIST	L2 UPCHARGES	
				COUNTER	CHASSIS
HNL1772RT	74	4.3	\$552	\$10	\$15

Compatible for use on 72"W x 30" or 36"D desktops and worksurfaces. For cleanest approach-side aesthetic, use on desk built with modular components; desk comprised of either 72"W x 30"D rectangle worksurface and 72"W x 27 7/8"H modesty/back panel, supported by 29 1/8"D pedestal(s) and/or end panel(s), or 72"W x 36"D worksurface and 72"W x 27 7/8"H modesty/back panel, supported by 35"D left and right end panels. The counter is 17"D with a 4" approach-side overhang; end panels are 12 3/8"D. Ships with Transaction counter organizer (model HTCOL52) is available as an option; fits under transaction counter; organizer is available in black only.

SPECIFYING EXAMPLE: HNL1772RT.BH.H.H

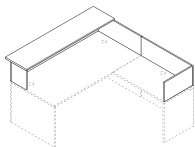

For Station with Right Return

L-Reception Station with Transaction Counter for Desk

72"W x 88"D x 14 5/8"H
72"W x 82"D x 14 5/8"H

HNL8472RT	103	4.5	\$881	\$10	\$25
HNL7872RT	101	4.5	\$860	\$10	\$25

NOTES: Intended for use on desk built with modular components, for clean approach-side aesthetic, connected to a return or modular return. Layout for 78" and 84"D footprints:

- 72"W x 78"D:
 - Desk = 72"W x 30"D worksurface, 72"W x 27 7/8"H modesty/back panel, supported by 29 1/8"D pedestal(s) and/or end panel(s).
 - Return = 48"W x 24"D return; or 48"W x 24"D worksurface with vertical grain, 48"W x 27 7/8"H modesty/back panel, supported by a 23 1/8"D pedestal and/or end panel.
- 72"W x 84"D:
 - Desk = 72"W x 36"D worksurface, 72"W x 27 7/8"H modesty/back panel, supported by 1-left and 1-right 35"D panel.
 - Return = 42"W x 24"D return; or 42"W x 24"D worksurface with vertical grain, 42"W x 27 7/8"H modesty/back panel, supported by a 23 1/8"D pedestal and/or end panel.
- 72"W x 88"D:
 - Desk = 72"W x 36"D worksurface, 72"W x 27 7/8"H modesty/back panel, supported by 1-left and 1-right 35"D end panel.
 - Return = 48"W x 24"D return; or 48"W x 24"D worksurface with vertical grain, 48"W x 27 7/8"H modesty/back panel, supported by a 23 1/8"D pedestal and/or end panel.

Comprised of 17"D transaction counter, with 4" approach-side overhang, for the desk and a vertical privacy panel extending the depth of the desk and width of the return. Ships with Transaction counter organizer (model HTCOL52) is available as an option; fits under transaction counter; organizer is available in black only.

SPECIFYING EXAMPLE: HNL8472RT.BH.H.H

NOTES:

- Reception Station Counter for Desk, and L-Reception Station with Transaction Counter for Desk, have profiled edgeband on the approach and user sides.
- L-Reception Station with Transaction Counter for Desk and Return has profiled edgeband on front side of transaction counter on desk approach-side only.
- For L-reception station layouts where the return is not against a wall, specify return using modular components, as the modesty/back panel can be specified without a grommet. Assembled returns come standard with cord grommet in modesty/back panel.

HOW TO SPECIFY

<p>Select Model Number</p> <p>H N L 1 7 7 2 R T</p>	<p>Select Edge Profile and Edge Color</p> <p>See page 29</p> <p>B H</p>	<p>Select Counter Color</p> <p>See page 29</p> <p>H</p>	<p>Select Chassis Color</p> <p>See page 29</p> <p>H</p>
--	--	--	--

CONCINNITY™

Reception Stations

GSA SIN 33721



Icon Legend on page 19

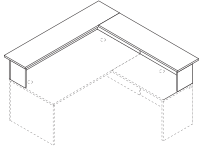

For Station with Right Return

DESCRIPTION	MODEL	SHIP WEIGHT	CUBE	L1 LIST	L2 UPCHARGES	
					COUNTER	CHASSIS
L- Reception Station with Transaction Counter for Desk and Return						
76"W x 88"D x 14 $\frac{5}{8}$ "H	HNL8472RLT	145	5.6	\$1056	\$10	\$25
76"W x 82"D x 14 $\frac{5}{8}$ "H	HNL7872RLT	139	5.6	\$1019	\$10	\$25
NOTES: Intended for use on desk built with modular components, for clean approach-side aesthetic, connected to a return or modular return. Layout for 78" and 84"D footprints:						
• 72"W x 78"D:						
- Desk = 72"W x 30"D worksurface, 72"W x 27 $\frac{7}{8}$ "H modesty/back panel, supported by 29 $\frac{1}{8}$ "D pedestal(s) and/or end panel(s).						
- Return = 48"W x 24"D worksurface with vertical grain, 48"W x 27 $\frac{7}{8}$ "H modesty/back panel, supported by a 23 $\frac{1}{8}$ "D pedestal and/or end panel.						
• 72"W x 78"D:						
- Desk = 72"W x 36"D worksurface, 72"W x 27 $\frac{7}{8}$ "H modesty/back panel, supported by 1-left and 1-right 35"D panel.						
- Return = 42"W x 24"D worksurface with vertical grain, 42"W x 27 $\frac{7}{8}$ "H modesty/back panel, supported by a 23 $\frac{1}{8}$ "D pedestal and/or end panel.						
• 72"W x 84"D:						
- Desk = 72"W x 36"D worksurface, 72"W x 27 $\frac{7}{8}$ "H modesty/back panel, supported by 1-left and 1-right 35"D end panel.						
- Return = 48"W x 24"D worksurface with vertical grain, 48"W x 27 $\frac{7}{8}$ "H modesty/back panel, supported by a 23 $\frac{1}{8}$ "D pedestal and/or end panel.						
! The 17"D transaction counter, with 4" overhang, extends around the perimeter of the station, across the width of the desk, as well as along the depth of the desk and width of the return. Ships with Transaction counter organizer (model HTCOL52) is available as an option; fits under transaction counter; organizer is available in black only.						
SPECIFYING EXAMPLE: HNL8472RLT.BH.H.H						

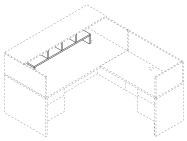

Transaction Counter Organizer						
48 $\frac{3}{4}$ "W x 11 $\frac{1}{8}$ "D x 13"H	HTCOL52	24	1.1	\$283	N/A	N/A
NOTES: Fits under reception station counters.						
! Black only.						
SPECIFYING EXAMPLE: HTCOL52.P						

NOTES:

- Reception Station Counter for Desk, and L-Reception Station with Transaction Counter for Desk, have profiled edgeband on the approach and user sides.
- ! L-Reception Station with Transaction Counter for Desk and Return has profiled edgeband on front side of transaction counter on desk approach-side only.
- ! For L-reception station layouts where the return is not against a wall, specify return using modular components, as the modesty/back panel can be specified without a grommet. Assembled returns come standard with cord grommet in modesty/back panel.

HOW TO SPECIFY

Select Model Number	Select Edge Profile and Edge Color	Select Counter Color	Select Chassis Color
See page 29	See page 29	See page 29	See page 29
H N L 8 4 7 2 R L T .	B H .	H .	H

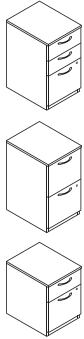

DESCRIPTION	MODEL	SHIP WEIGHT	CUBE	L1 LIST	L2 UPCHARGES		
					TOP	CHASSIS	FRONTS
Mobile Pedestal — 15¾" W							
15¾"W x 20⅞"D x 28⅜"H, Box/Box/File	HNL2116MBBF	69	7.4	\$898	N/A	\$20	\$10
15¾"W x 20⅞"D x 28⅜"H, File/File	HNL2116MFF	70	7.4	\$898	N/A	\$20	\$10
15¾"W x 20⅞"D x 21½"H, Box/File	HNL2116MBF	55	5.8	\$760	N/A	\$20	\$10

NOTES: Well suited to a variety of office layouts, including private, open floor plan, and cubicle workspaces. Design positions the center of gravity towards the back of the cabinet to inhibit tipping. All drawers lock; interchangeable core removable lock makes re-keying quick and easy. Finish of lock is determined by, and aligned with, the handle finish specified. Keyed alike cores must be ordered separately; specify model HF23B (Black) or HF23S (Satin) and specific key number required. Pedestals, excluding cushion option, are sized to be positioned under 29½"H worksurfaces. Seat cushion model HLSL2016PH2 is optional. Cushion adds 1" to the height of the pedestal. Box/File unit with cushion will fit below 29½"H worksurface. ¾" thick top with flat edgeband; back inside end panel construction. Ships fully assembled.

SPECIFYING EXAMPLE: HNL2116MBBF.E.H.H

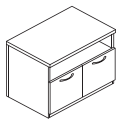

Mobile Pedestal — 30" W							
30"W x 20"D x 21½"H, Shelf/File/Cabinet	HNL2030MSFC	105	10.7	\$1129	\$10	\$25	\$15

NOTES: Sized to align with 20"D x 20½"H low credenzas. Open shelf over file drawer left and cabinet with door right. Design positions the center of gravity towards the back of the cabinet to inhibit tipping. Seat cushion model HNL2030CH2 is optional. Cushion adds 1" to the height of the pedestal. 1⅞" thick top matches low credenza design. Ships fully assembled.

SPECIFYING EXAMPLE: HNL2030MSFC.BH.E.H.H.H

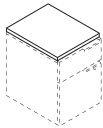

DESCRIPTION	MODEL	SHIP WEIGHT	CUBE	LIST PRICE BY FABRIC GRADE					
				1	2	3	4	5	6
Mobile Pedestal Cushion									
30"W x 20"D x 1"H	HLSL2030CH2	9	1.9	\$372	\$408	\$444	\$480	\$526	\$573
15¾"W x 20"D x 1"H	HLSL2016PH2	6	1.1	\$309	\$333	\$357	\$381	\$412	\$443

NOTES: See pages 22-24 for available fabrics.

SPECIFYING EXAMPLE: HLSL2016PH2.APN23

NOTES:

- Mobile pedestals roll easily on four casters to provide convenient, flexible placement of personal storage needs.
- Drawers operate on steel ball-bearing suspension with full extension.
- File drawers include hangrails for side-to-side letter and legal filing; and front-to-back for letter filing.
- ! 28⅜"H mobile pedestals are not designed for use with the 28½"H metal O-leg due to interference caused by (1) the O-leg worksurface attachment bracket, and (2) the external support channel on the underside of a 72", 66", and 60"W rectangle worksurface supported by O-leg(s).

HOW TO SPECIFY

<p>Select Model Number</p> <p>H N L 2 1 1 6 M B B F .</p>	<p>Select Handle</p> <p>A Cylinder – Satin B Cylinder – Black C Canopy – Satin D Canopy – Black E Loop – Satin F Loop – Black</p> <p>E .</p>	<p>Select Chassis Color</p> <p>See page 29</p> <p>H .</p>	<p>Select Drawer Front Color</p> <p>See page 29</p> <p>H</p>
--	---	--	---

<p>Select Model Number</p> <p>H N L 2 0 3 0 M S F C .</p>	<p>Select Edge Profile and Edge Color</p> <p>See page 29</p> <p>B H .</p>	<p>Select Handle</p> <p>A Cylinder – Satin B Cylinder – Black C Canopy – Satin D Canopy – Black E Loop – Satin F Loop – Black</p> <p>E .</p>	<p>Select Top Color</p> <p>See page 29</p> <p>H .</p>	<p>Select Chassis Color</p> <p>See page 29</p> <p>H .</p>	<p>Select Drawer/Door Front Color</p> <p>See page 29</p> <p>H</p>
--	--	---	--	--	--

CONCINNITY™

Lateral Files

GSA SIN 33721



Icon Legend on page 19



DESCRIPTION	MODEL	SHIP WEIGHT	CUBE	L1 LIST	L2 UPCHARGES		
					TOP	CHASSIS	FRONTS
Lateral File 36"W x 24"D x 59½"H, 4-Drawer	HNL2436LD4	276	34.3	\$2125	\$15	\$30	\$30
36"W x 24"D x 45½"H, 3-Drawer	HNL2436LD3	222	26.0	\$1762	\$15	\$25	\$25
36"W x 24"D x 29½"H, 2-Drawer	HNL2436LD2	178	18.4	\$1167	\$15	\$20	\$20

NOTES: Equipped with safety restraints; mechanical interlock inhibits the extension of more than one drawer at a time; counterweight positions the center of gravity towards the back of the cabinet to inhibit tipping. 24" depth aligns evenly with credenzas, returns, storage cabinet, storage/file cabinet, storage cabinet/lateral file, wardrobe/storage cabinet, wardrobe/bookcase, storage towers, and 24"D modular components. 29½"H unit is sized to accommodate 36"W stack-on storage or bookcase hutch options. Drawers lock; interchangeable core removable lock makes re-keying quick and easy. Finish of lock is determined by, and aligned with, the handle finish specified. Keyed alike cores must be ordered separately; specify model HF23B (Black) or HF23S (Satin) and specific key number required. Ship fully assembled. 30"W two-drawer size can be specified and assembled using modular components. Drawers include hangrails to accept folders in letter or legal size.

SPECIFYING EXAMPLE: HNL2436LD2.BH.E.H.H.H

HOW TO SPECIFY

Select Model Number	Select Edge Profile and Edge Color	Select Handle	Select Top Color	Select Chassis Color	Select Drawer Front Color
	See page 29	A Cylinder – Satin B Cylinder – Black C Canopy – Satin D Canopy – Black E Loop – Satin F Loop – Black	See page 29	See page 29	See page 29
H N L 2 4 3 6 L D 4 .	B H .	E .	H .	H .	H .



CONCINNITY™ Storage Cabinets

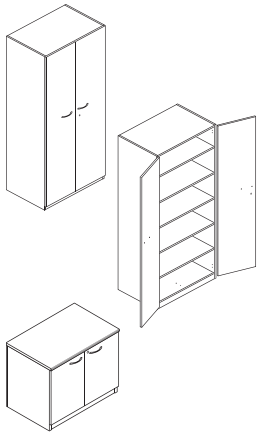

DESCRIPTION	MODEL	SHIP WEIGHT	CUBE	L1 LIST	L2 UPCHARGES		
					TOP	CHASSIS	FRONTS
Storage Cabinet with Laminate Doors							
36"W x 24"D x 78 1/8"H (shown)	HNL243679SC	317	47.4	\$2301	N/A	\$60	\$25
36"W x 24"D x 64 3/4"H	HNL243665SC	252	40.8	\$2165	N/A	\$55	\$20
36"W x 24"D x 29 1/2"H	HNL243629SC	158	18.4	\$1039	\$15	\$20	\$20

NOTES: 29 1/2"H size has one adjustable interior shelf. Shelf adjusts in 2 1/2" increments over a total range of 10"H, 64 3/4"H and 78 1/8" have five shelves (four adjustable) and six shelves (five adjustable), respectively; shelves adjust in 2 1/2" increments. Locking doors. 24" depth aligns evenly with credenzas, returns, lateral files, storage/file cabinet, storage cabinet/lateral file, wardrobe/storage cabinet, wardrobe/bookcase, storage tower, bookcase with coat hook, and 24"D modular components. 29 1/2"H unit is sized to accommodate 36"W stack-on storage or bookcase hutch options. Ships fully assembled. 30"W x 24"D x 29 1/2"H freestanding unit can be built using modular components.

SPECIFYING EXAMPLE (29 1/2"H): HNL243629SC.BH.E.H.H.H

SPECIFYING EXAMPLE (64 3/4-78 1/8"H): HNL243665SC.E.H.H

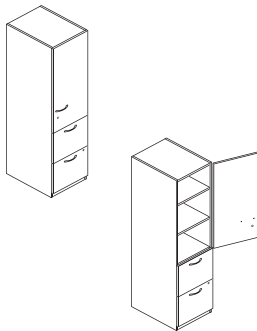

DESCRIPTION	MODEL	SHIP WEIGHT	CUBE	L1 LIST	L2 UPCHARGES TOP	L2 UPCHARGES CHASSIS	L2 UPCHARGES FRONTS
Storage/File Cabinet							
18"W x 24"D x 64 3/4"H, File/File, Laminate Door Hinged Right (shown)	HNL241865SFLR	184	21.6	\$1740	N/A	\$25	\$15
18"W x 24"D x 64 3/4"H, File/File, Laminate Door Hinged Left	HNL241865SFLL	184	21.6	\$1740	N/A	\$25	\$15
18"W x 24"D x 64 3/4"H, File/File, Open Shelves	HNL241865SFX	169	21.6	\$1651	N/A	\$25	\$15

NOTES: Versatile unit features a storage cabinet plus two file drawers. Storage cabinet includes three shelves, two are adjustable; shelves adjust in 2 1/2" increments. Can be specified with door hinged left, door hinged right, or no door/open shelves. File drawers operate on steel ball-bearing suspensions with full extension. File drawers include hangrails to accept folders in letter or legal size. Storage cabinet door and file drawers lock separately; the two locks are keyed alike. Unit height is designed to match desk, credenza, or return plus 35 1/4"H stack-on storage (= 64 3/4"). Ships fully assembled.

SPECIFYING EXAMPLE (WITH DOOR): HNL241865SFLR.E.H.H

SPECIFYING EXAMPLE (WITHOUT DOOR): HNL241865SFX.E.H.H

NOTES:

- Interchangeable core removable lock makes re-keying quick and easy.
- Finish of lock is determined by, and aligned with, the handle finish specified.
- Keyed alike cores must be ordered separately; specify model HF23B (Black) or HF23S (Satin) and specific key number required.

HOW TO SPECIFY

<p>Select Model Number</p> <p>H N L 2 4 3 6 2 9 S C .</p>	<p>Select Edge Profile and Edge Color</p> <p>See page 29</p> <p>B H .</p>	<p>Select Handle</p> <p>A Cylinder - Satin B Cylinder - Black C Canopy - Satin D Canopy - Black E Loop - Satin F Loop - Black</p> <p>E .</p>	<p>Select Top Color</p> <p>See page 29</p> <p>H .</p>	<p>Select Chassis Color</p> <p>See page 29</p> <p>H .</p>	<p>Select Drawer Front Color</p> <p>See page 29</p> <p>H .</p>
--	--	---	--	--	---

<p>Select Model Number</p> <p>H N L 2 4 3 6 6 5 S C .</p> <p>H N L 2 4 1 8 6 5 S F X .</p>	<p>Select Handle</p> <p>A Cylinder - Satin B Cylinder - Black C Canopy - Satin D Canopy - Black E Loop - Satin F Loop - Black</p> <p>E .</p> <p>E .</p>	<p>Select Chassis Color</p> <p>See page 29</p> <p>H .</p> <p>H .</p>	<p>Select Drawer Front Color</p> <p>See page 29</p> <p>H .</p> <p>H .</p>
---	--	---	--

CONCINNITY™ Storage Cabinets

GSA SIN 33721



Icon Legend on page 19

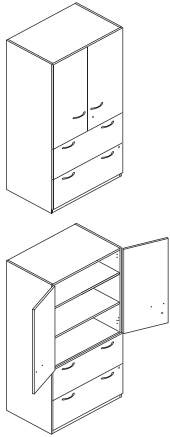

DESCRIPTION	MODEL	SHIP WEIGHT	CUBE	L1 LIST	L2 UPCHARGES		
					TOP	CHASSIS	FRONTS
Storage Cabinet/Lateral File, Laminate Doors 36"W x 24"D x 64¾"H	HNL243665SLL	328	40.8	\$2334	N/A	\$55	\$20

NOTES: Cabinet includes one fixed and two full-width adjustable shelves; adjustable shelves can be removed. Overall storage compartment measures 34"W x 22"D x 34½"H and will accommodate supplies, books and binders. Lateral file equipped with mechanical interlock to inhibit the extension of more than one drawer at a time. Lateral file drawers include handrails to accept folders in letter or legal size. Storage cabinet and lateral file lock independently; upper lock secures cabinet; lower locks secure file drawers. Locks are keyed alike. Door hinges rotate to 94 degrees. Unit height is designed to match desk, credenza, or return plus 35¼"H stack-on storage (= 64¾"). Ships fully assembled.

SPECIFYING EXAMPLE: HNL243665SLL.E.H.H

NOTES:

- Interchangeable core removable lock makes re-keying quick and easy.
- Finish of lock is determined by, and aligned with, the handle finish specified.
- Keyed alike cores must be ordered separately; specify model HF23B (Black) or HF23S (Satin) and specific key number required.

HOW TO SPECIFY

<p>Select Model Number</p> <p>H N L 2 4 3 6 6 5 S L L .</p>	<p>Select Handle</p> <p>A Cylinder - Satin B Cylinder - Black C Canopy - Satin D Canopy - Black E Loop - Satin F Loop - Black</p> <p>E .</p>	<p>Select Chassis Color</p> <p>See page 29</p> <p>H .</p>	<p>Select Door/Drawer Front Color</p> <p>See page 29</p> <p>H</p>
--	--	--	--



DESCRIPTION	MODEL	SHIP WEIGHT	CUBE	L1 LIST	L2 UPCHARGES	
					CHASSIS	FRONTS
Wardrobe/Storage Cabinet, Laminate Doors — 36"W 36"W x 24"D x 78 ¹ / ₈ "H 36"W x 24"D x 64 ³ / ₄ "H	HNL243679WL	303	40.8	\$2643	\$60	\$25
	HNL243665WL	284	40.8	\$2533	\$55	\$20

NOTES: Spacious design combines a cabinet with adjustable shelves and a generous personal wardrobe compartment with a coat rod and upper shelf. 64³/₄"H and 78¹/₈"H have five shelves (four adjustable) and six shelves (five adjustable), respectively; shelves adjust in 2¹/₂" increments. One lock secures both doors. Ships fully assembled.

SPECIFYING EXAMPLE: HNL243665WL.E.H.H

Wardrobe/Storage Cabinet, Laminate Door — 18"W 18"W x 24"D x 78 ¹ / ₈ "H, Hinged Right (shown) 18"W x 24"D x 78 ¹ / ₈ "H, Hinged Left 18"W x 24"D x 64 ³ / ₄ "H, Hinged Right 18"W x 24"D x 64 ³ / ₄ "H, Hinged Left	HNL241879WLR	205	24.8	\$1734	\$30	\$20
	HNL241879WLL	205	24.8	\$1734	\$30	\$20
	HNL241865WLR	157	21.6	\$1590	\$25	\$15
	HNL241865WLL	157	21.6	\$1590	\$25	\$15

NOTES: Design includes coat rod and shelves. 64³/₄"H and 78¹/₈"H have five shelves (four adjustable) and six shelves (five adjustable), respectively; shelves adjust in 2¹/₂" increments. Middle shelves can be removed to provide space for garments; coat rod can be removed for storage only applications. Lock to secure contents. Ships fully assembled.

SPECIFYING EXAMPLE: HNL241865WLR.E.H.H

Wardrobe/Bookcase, Laminate Door 36"W x 24"D x 78 ¹ / ₈ "H, Wardrobe Left, Bookcase Right 36"W x 24"D x 78 ¹ / ₈ "H, Wardrobe Right, Bookcase Left 36"W x 24"D x 64 ³ / ₄ "H, Wardrobe Left, Bookcase Right 36"W x 24"D x 64 ³ / ₄ "H, Wardrobe Right, Bookcase Left (shown)	HNL243679WLBR	302	47.4	\$2533	\$60	\$25
	HNL243679WRBL	302	47.4	\$2533	\$60	\$25
	HNL243665WLBR	230	40.8	\$2395	\$55	\$20
	HNL243665WRBL	230	40.8	\$2395	\$55	\$20

NOTES: Combination closed-door wardrobe closet and open shelf bookcase. 64³/₄"H and 78¹/₈"H bookcases have five and six fixed shelves, respectively. Locking wardrobe compartment includes a coat rod and one shelf; shelf is positioned above the coat rod. Bookcase can be accessed from front or side. Left (L) model is wardrobe on left, bookcase on right; Right (R) model is wardrobe on right, bookcase on left. Ships fully assembled.

SPECIFYING EXAMPLE: HNL243665WRBL.E.H.H

NOTES:

- Heights designed to match desk, credenza, or return plus 35¹/₄"H stack-on storage (= 64³/₄") or 48⁵/₈"H stack-on storage (= 78¹/₈"H).
- Finish of locks is determined by, and aligned with, the handle finish specified.
- Keyed alike cores must be ordered separately; specify model HF23B (Black) or HF23S (Satin) and specific key number required.

HOW TO SPECIFY

<p>Select Model Number</p> <p>H N L 2 4 3 6 5 W L .</p>	<p>Select Handle</p> <p>A Cylinder – Satin B Cylinder – Black C Canopy – Satin D Canopy – Black E Loop – Satin F Loop – Black</p> <p>E .</p>	<p>Select Chassis Color</p> <p>See page 29</p> <p>H .</p>	<p>Select Door Front Color</p> <p>See page 29</p> <p>H</p>
--	--	--	---

CONCINNITY™

Storage Towers

GSA SIN 33721

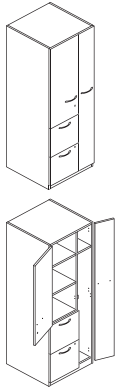

Icon Legend on page 19

**DESCRIPTION****Storage Towers, Laminate Doors — 24" W**24"W x 24"D x 78¹/₈"H, Wardrobe Hinged Left, Cabinet Hinged Right**MODEL****SHIP WEIGHT****CUBE****L1 LIST****L2 UPCHARGES**
CHASSIS **FRONTS**24"W x 24"D x 78¹/₈"H, Wardrobe Hinged Right, Cabinet Hinged Left**HNL242479TLL**

284

32.4

\$2455**\$70****\$45**24"W x 24"D x 64³/₄"H, Wardrobe Hinged Left, Cabinet Hinged Right**HNL242479TLR**

284

32.4

\$2455**\$70****\$45**24"W x 24"D x 64³/₄"H, Wardrobe Hinged Right, Cabinet Hinged Left (shown)**HNL242465TLL**

241

27.6

\$2235**\$60****\$35****HNL242465TLR**

241

27.6

\$2235**\$60****\$35**

NOTES: Versatile design includes a wardrobe closet, storage cabinet, and two file drawers, in one compact unit. Wardrobe contains a coat rod and upper shelf. 64³/₄"H and 78¹/₈"H cabinets have three shelves (two adjustable) and four shelves (three adjustable), respectively; shelves adjust in 2¹/₂" increments. File drawers operate on ball-bearing suspensions with full extension. File drawer design includes integrated hangrails for side-to-side letter or legal filing; and front-to-back for letter filing. Upper lock secures wardrobe closet and storage cabinet; lower lock secures file drawers; the two locks are keyed alike. Left (L) model is wardrobe hinged left, cabinet hinged right; Right (R) model is wardrobe hinged right, cabinet hinged left. Ships fully assembled.

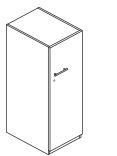
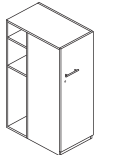
SPECIFYING EXAMPLE: HNL242465TLR.E.H.HHinged Right
HNL241850TLR shownHinged Right
HNL301850TLR shown**Storage Towers, Laminate Door — 50" H**

18"W x 30"D x 50"H, Hinged Right

HNL301850TLR

135

19.8

\$1385**\$50****\$35**

18"W x 30"D x 50"H, Hinged Left

HNL301850TLL

135

19.8

\$1385**\$50****\$35**

18"W x 24"D x 50"H, Hinged Right

HNL241850TLR

121

15.9

\$1245**\$50****\$35**

18"W x 24"D x 50"H, Hinged Left

HNL241850TLL

121

15.9

\$1245**\$50****\$35**

NOTES: Low profile design is well-suited for open plan layouts. Can be used next to 29¹/₂"H to standing, 42"H worksurfaces. Cabinet includes coat hook on back of door, perfect for jackets, sweaters, and purses. Two adjustable interior shelves, plus bottom of unit; shelves adjust in 2¹/₂" increments. 30"D size has a slim side access storage space at rear of unit with two fixed interior shelves; the lower shelf is positioned to align with a 29¹/₂"H worksurface, the upper shelf with a 42"H worksurface. Hardware bag includes an extra coat hook which can be positioned on the side of the unit, below the worksurface; ideal for back packs. Left (L) model is door hinged left; Right (R) model is door hinged right. Worksurface tower bracket kit (model HSTB2W1) can be used to attach a worksurface directly to the tower. Bracket (1) eliminates the need for one end panel or O-leg support; (2) is not designed to be used as a support when a stack-on storage unit is placed over bracket. Ships fully assembled.

SPECIFYING EXAMPLE: HNL182450TLR.E.H.H**NOTES:**

- Equipped with interchangeable core removable locks.
- Finish of locks is determined by, and aligned with, the handle finish specified.
- Keyed alike cores must be ordered separately; specify model HF23B (Black) or HF23S (Satin) and specific key number required.

CABINET/WARDROBE/TOWER SOLUTIONS BY SIZE

	Low/50"H	Standard/64 ³ / ₄ "H	Executive/78 ¹ / ₈ "H
Storage Cabinet with Doors		•	•
Storage/File Cabinet		•	
Storage Cabinet/Lateral File		•	
Wardrobe/Storage Cabinet		•	•
Wardrobe/Bookcase		•	•
Storage Tower		•	•
Storage Tower with Side Access on 30"D	•		
Bookcase with Coat Hook		•	

HOW TO SPECIFYSelect
Model Number

H N L 2 4 2 4 6 5 T L R .

Select
Handle

- A Cylinder – Satin
- B Cylinder – Black
- C Canopy – Satin
- D Canopy – Black
- E Loop – Satin
- F Loop – Black

E .

Select
Chassis Color

See page 29

H .

Select
Door Front Color

See page 29

E

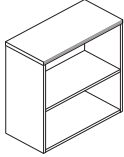

DESCRIPTION

Bookcase with Adjustable Shelves

- 30"W x 14 1/4"D x 78 1/8"H, 6-Shelf
- 30"W x 14 1/4"D x 65"H, 5-Shelf
- 30"W x 14 1/4"D x 52 3/4"H, 4-Shelf
- 30"W x 14 1/4"D x 42"H, 3-Shelf
- 30"W x 14 1/4"D x 29 1/2"H, 2-Shelf

MODEL	SHIP WEIGHT	CUBE	L1 LIST	L2 UPCHARGES	
				TOP	CHASSIS
HNL1530BK6	170	25.7	\$947	\$30	\$35
HNL1530BK5	143	21.1	\$840	\$25	\$30
HNL1530BK4	118	17.4	\$727	\$20	\$25
HNL1530BK3	95	14.1	\$640	\$15	\$20
HNL1530BK2	69	10.2	\$562	\$15	\$15

NOTES: Profiled top edge; choose from edge detail options. Number of total and adjustable shelves:

Height	Shelves	Adjustable Shelves
29 1/2"	2	1
42"	3	2
52 3/4"	4	3
65"	5	4
78 1/8"	6	5

3/4" thick shelves adjust in 1/4" increments. Inside shelf dimensions on all units are 28 1/2"W x 13 1/4"D. Ships fully assembled.

SPECIFYING EXAMPLE: HNL1530BK2.BH.H.H

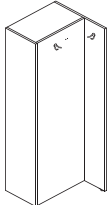
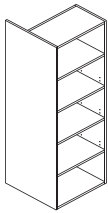

Back View

DESCRIPTION

Bookcase with Coat Hooks

- 24"W x 24"D x 64 3/4"H, 5-Shelf, with Coat Hooks, Right (shown)
- 24"W x 24"D x 64 3/4"H, 5-Shelf, with Coat Hooks, Left

MODEL	SHIP WEIGHT	CUBE	L1 LIST PRICE	L2
				UPCHARGE
HNL2424BK5CR	133	27.6	\$958	\$30
HNL2424BK5CL	133	27.6	\$958	\$30

NOTES: Inside shelf dimensions are 28 1/2"W x 13 1/4"D. Two out of sight coat hooks for garments are secluded behind bookcase. One end panel measures 14 1/4"D, the other 24"D. "R" indicates coat hook access is on the right and the full 24"D end panel on the left; for use next to credenza or return with pedestal on right. "L" indicates coat hook access is on the left and the full 24"D end panel is on the right; for use next to credenza or return with pedestal on left. Unit height is designed to match desk, credenza, or return plus 35 1/4"H stack-on storage (= 64 3/4"). 3/4" thick, non-profiled top edge. Not available in two-tone laminate color combinations. Ships fully assembled.

SPECIFYING EXAMPLE: HNL2424BK5CR.H

HOW TO SPECIFY

<p>Select Model Number</p> <p>H N L 1 5 3 0 B K 2 .</p>	<p>Select Edge Profile and Edge Color</p> <p>See page 29</p> <p>B H .</p>	<p>Select Top Color</p> <p>See page 29</p> <p>H .</p>	<p>Select Chassis Color</p> <p>See page 29</p> <p>H</p>
<p>Select Model Number</p> <p>H N L 2 4 2 4 B K 5 C R .</p>	<p>Select Laminate</p> <p>See page 29</p> <p>H</p>		

CONCINNITY™ COMPONENTS

MODULAR COMPONENTS

- Smart, adaptable, reconfigurable assortment to maximize office layout flexibility and optimize floor space.
- Components for all popular office layouts.
- Selection allows user to choose their own workstation shape, size, and storage.
- Sizes for large and small spaces:
 - 36"D x 72"W or 84"W
 - 30"D — six sizes up to 84"W
 - 24"D — in 6" increments, from 30"W to 96"W
- Worksurfaces supported by post legs with casters provide added layout flexibility.
- Mobile desks quickly convert an office into a small conference space; desks roll easily and can be repositioned in seconds.
- Grommet options provide cord management from the top, side, and back in appropriate models.
- Broad menu of under-surface storage to enable user to specify the solution that best meets their individual needs.
 - Non-handed units can be configured to meet individual tastes and reconfigured when preferences or floor space requirements change.
 - Applications include:
 - The ability to “build” contiguous customized/personalized storage behind the desk that looks like custom architectural millwork, but at a fraction of the price. Allows for multiple storage pedestals to be configured under a single top with clean lines and no gaps.
 - Choosing the storage solution to go under desks, credenzas, and returns.

WORKSURFACES

- Available in a variety of shapes and sizes.
- Scratch-, stain-, and spill-resistant laminate over durable 1½" solid core high performance particleboard; resists warping.
- An external support channel, for attachment under worksurfaces, is required for all unsupported spans — a distance in which there is not a vertical support (point of contact) between the underside of the worksurface and the floor — greater than 54"W.
- For tri-oval and beaded edge options on tops with horizontal grain, there is a shaped profile on the user and approach sides, and a flat edge on the ends.
- For tri-oval and beaded edge options on tops with vertical grain, there is a shaped profile on the user side and a flat edge on the approach side and the ends.
- Grommets are an option and require specification. If grommets are selected, grommets come in a pre-determined location.

- Must be specified with support components; for pedestal, end panel, column, and leg options, see “Components — Supports” listings.

SUPPORTS

- For use with rectangle, bow, bullet, and extended corner worksurfaces.
- Available in 28½" and 41"H.
- Adjustable hex glides allow floor-standing units to be easily leveled, without lifting, to compensate for uneven floors; glides have 1¼" adjustable range on most components; 2" on O-legs.
- Bottom of laminate end panels are edgebanded for added strength and to seal out moisture.

FOR 29½"H WORKSURFACES

- Specify from a broad assortment of solutions, including —
 - Modular Pedestals
 - Laminate end panels (must be used in conjunction with a laminate modesty panel)
 - Laminate L-shaped end panels
 - Laminate T-shaped end panels
 - Metal O-legs — for use with worksurfaces up to 78"W (when using an 84" or wider worksurface, cannot use two O-legs; must use at least one 1½" or wider pedestal for the other support).
 - 4½" diameter metal column
 - 2" square metal post leg

FOR 42"H WORKSURFACES

- 42", fixed standing-height workstations give users the option of changing postures from sitting to standing throughout the day to help achieve their wellness goals.
- Specify supports from —
 - Modular Pedestals
 - Laminate end panels (must be used in conjunction with a laminate modesty panel)
 - Laminate L-shaped end panels
 - Metal O-legs
- When combined with a stool-height task chair, provides users the benefit of alternating their work between a seated or standing position.
- An external support channel, for attachment under worksurfaces, is required for all unsupported spans greater than 54"W.

- Worksurface End Support (panel, leg, column, base, pedestal) requirements by product type are as follows —
 - Desk, peninsula, or credenza — qty. 2
 - Return — qty. 1
 - Island extension — qty. 1

COORDINATE™ HEIGHT ADJUSTABLE BASE

- Height adjustable bases deliver a healthier style of working by allowing a seamless transition between sitting and standing throughout the day. For open, private, or training spaces.
- Frame rises from 21⁵/₈" to 47³/₄".
- Telescoping base design.
- Accommodates rectangle worksurface sizes 24" to 30"D and 48" to 72"W.
- Standard-height adjustable control included with base. Memory control allows preset worksurface heights for consistency.
- Shipped complete with a pre-assembled electric motor.

CONCINNITY™

Components — Worksurfaces

GSA SIN 33721



Icon Legend on page 19

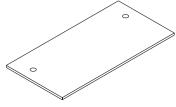

DESCRIPTION	MODEL	SHIP WEIGHT	CUBE	L1 LIST PRICE	L2 UPCHARGE
Rectangle Worksurface with Horizontal Grain					
84"W x 36"D	HNLRC3684	105	7.7	\$640	\$30
72"W x 36"D (shown)	HNLRC3672	90	6.7	\$534	\$30
84"W x 30"D	HNLRC3084	88	6.5	\$518	\$25
78"W x 30"D	HNLRC3078	81	6.1	\$468	\$25
72"W x 30"D	HNLRC3072	75	5.6	\$429	\$20
66"W x 30"D	HNLRC3066	69	5.2	\$395	\$20
60"W x 30"D	HNLRC3060	62	4.7	\$369	\$20
48"W x 30"D	HNLRC3048	50	3.9	\$301	\$15
96"W x 24"D	HNLRC2496	80	5.8	\$532	\$30
90"W x 24"D	HNLRC2490	75	5.5	\$522	\$30
84"W x 24"D	HNLRC2484	70	5.3	\$493	\$25
78"W x 24"D	HNLRC2478	65	4.9	\$440	\$20
72"W x 24"D	HNLRC2472	60	4.6	\$366	\$20
66"W x 24"D	HNLRC2466	55	4.2	\$353	\$20
60"W x 24"D	HNLRC2460	50	3.9	\$325	\$20
54"W x 24"D	HNLRC2454	45	3.5	\$299	\$20
48"W x 24"D	HNLRC2448	40	3.1	\$274	\$15
42"W x 24"D	HNLRC2442	35	2.8	\$256	\$15
36"W x 24"D Rectangle Worksurface/Pedestal Top	HNLRC2436	30	2.4	\$230	\$15
30"W x 24"D Rectangle Worksurface/Pedestal Top	HNLRC2430	25	2.1	\$230	\$15

NOTES: See chart on page 36 for cord management options.

- When grommets are specified for 30"D and 36"D rectangle worksurfaces, pre-drilled holes will not be included for a 4½" diameter support column.

NOTES:

- Grain direction on all rectangle worksurfaces runs horizontal (side-to-side) except as follows: 30"W - 36"W - 42"W - 48"W - 54"W - 60"W x 24"D tops can be specified with horizontal (side-to-side) or vertical (front-to-back) grain.
- 42"W and 48"W x 20"D tops are available with vertical (front-to-back) grain only.
- 48" - 72"W x 24" - 30"D worksurfaces are compatible for use with height adjustable electric base model HHAB3S2L.
- For standing-height requirements, use worksurface with 41"H O-leg, end panel, L-shaped end panel, or pedestal supports.
- For mobile desks and tables, use post leg with casters.
- For paper organizers, see page 110.
- Attachment of above privacy screen models requires a minimum 1" clear space/overhang on the underside of worksurface.
- Worksurfaces used with Coordinate™ Height Adjustable Bases should have 1" perimeter gap on each side to provide clearance between other furniture. Failure to do so risks injury or product damage (not covered by warranty).
- When using end panels or O-legs with 84", 90", or 96"W worksurfaces, interior weight-bearing support components are required to minimize worksurface deflection.
- Attachment of above/below privacy screen models requires a minimum 2" clear space/overhang on the underside of the worksurface.
- Steel external support channel can be attached to the underside of worksurfaces that are subjected to heavier loads. Channel is recommended to provide extra support on unsupported spans of 54"W or greater or per user preference. Ordered separately from worksurface.
- If using a 54"W or 60"W floating modesty panel, it is not necessary to specify an external support channel.
- When using an external support channel under the worksurface, the depth clearance for center drawers and keyboard platforms decreases by 8".
- See "External Channel (Recommended Use)" chart on page 85.

HOW TO SPECIFY

Select Model Number See page 29 H N L R C 3 6 8 4	Select Edge Profile and Edge Color See page 29 B H	Select Worksurface Grommet Finish P Black T1 Platinum X No Grommet P	Select Worksurface Color See page 29 H
---	--	--	--



CONCINNITY™

Components — Worksurfaces

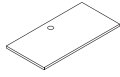

DESCRIPTION	MODEL	SHIP WEIGHT	CUBE	L1 LIST PRICE	L2 UPCHARGE
Rectangle Worksurface with Vertical Grain					
60"W x 24"D	HNLRC2460V	50	3.9	\$325	\$20
54"W x 24"D	HNLRC2454V	45	3.5	\$299	\$20
48"W x 24"D (shown)	HNLRC2448V	40	3.1	\$274	\$15
42"W x 24"D	HNLRC2442V	35	2.8	\$256	\$15
36"W x 24"D Rectangle Worksurface/Pedestal Top	HNLRC2436V	30	2.4	\$230	\$15
30"W x 24"D Rectangle Worksurface/Pedestal Top	HNLRC2430V	25	2.1	\$230	\$15
48"W x 20"D	HNLRC2048V	33	2.7	\$257	\$10
42"W x 20"D	HNLRC2042V	29	2.3	\$237	\$10

NOTES: Can be used in a host of applications, including as a desk, credenza, return, bridge, stationary or mobile table surface, in U- or L-shaped configurations, as part of a work wall layout with an island extension, or with the height adjustable electric base. The conference overhang dimension on the approach side of worksurfaces varies depending on the supports and modesty panels specified. Top can be positioned with a cantilevered conference overhang on one end when used with select worksurface supports, including an O-leg or 9½"W modular pedestal. For return applications in which there is an unsupported span wider than 54", such as a 72"W x 24"D worksurface supported by a 15¾"W modular pedestal (= 56¼") or a 60"W x 24"D worksurface supported by a 1½" thick end panel (= 58¾"), use internal support panel model HNL11SUPP. For bridges wider than 54", use internal support panel HNL11SUPP. When using a 30"W, 36"W, 42"W, or 48"W rectangle worksurface as a bridge, no support legs are needed. When specifying a 84"W, 90"W, or 96"W worksurface, cannot use two O-legs for the supports. In these applications, the maximum number of supports that can be an O-leg is one; must choose from a 15¾" or wider modular pedestal for use as the additional support component. For applications requiring connection to an adjoining worksurface, two flat brackets are included with 24"D and 20"D worksurfaces that are ≤48"W; one flat bracket is included with 24"D worksurfaces that are ≥54"W. Underside of worksurface includes pilot mounting holes for O-leg, 1½" thick laminate end panel, pedestals, and flat brackets. See chart on page 36 for cord management options.

ⓘ When grommets are specified for 30"D and 36"D rectangle worksurfaces, pre-drilled holes will not be included for attachment of a 4½" diameter support column.

NOTES:

- Grain direction on all rectangle worksurfaces runs horizontal (side-to-side) except as follows: 30"W - 36"W - 42"W - 48"W - 54"W - 60"W x 24"D tops can be specified with horizontal (side-to-side) or vertical (front-to-back) grain.
- 42"W and 48"W x 20"D tops are available with vertical (front-to-back) grain only.
- 48" - 72"W x 24" - 30"D worksurfaces are compatible for use with height adjustable electric base model HHAB3S2L.
- For standing-height requirements, use worksurface with 41"H O-leg, end panel, L-shaped end panel, or pedestal supports.
- For mobile desks and tables, use post leg with casters.
- For paper organizers, see page 110.
- ⓘ Attachment of above privacy screen models requires a minimum 1" clear space/overhang on the underside of worksurface.
- ⓘ Worksurfaces used with Coordinate™ Height Adjustable Bases should have 1" perimeter gap on each side to provide clearance between other furniture. Failure to do so risks injury or product damage (not covered by warranty).
- ⓘ Attachment of above/below privacy screen models requires a minimum 2" clear space/overhang on the underside of the worksurface.
- ⓘ Steel external support channel can be attached to the underside of worksurfaces that are subjected to heavier loads. Channel is recommended to provide extra support on unsupported spans of 54"W or greater or per user preference. Ordered separately from worksurface.
- ⓘ If using a 54"W or 60"W floating modesty panel, it is not necessary to specify an external support channel.
- ⓘ When using an external support channel under the worksurface, the depth clearance for center drawers and keyboard platforms decreases by 8".
- ⓘ See "External Channel (Recommended Use)" chart on page 85.

HOW TO SPECIFY

Select Model Number H N L R C 2 4 6 0 V	Select Edge Profile and Edge Color See page 29 B H	Select Worksurface Grommet Finish P Black T1 Platinum X No Grommet P	Select Worksurface Color See page 29 H
---	---	---	---

CONCINNITY™

Components — Worksurfaces

GSA SIN 33721

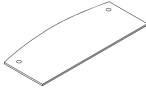
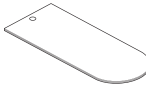

Icon Legend on page 19

	DESCRIPTION	MODEL	SHIP WEIGHT	CUBE	L1 LIST PRICE	L2 UPCHARGE
	Bow Worksurface					
	84"W x 36"D	HNLBW3684	94	7.7	\$683	\$30
	72"W x 36"D	HNLBW3672	80	6.7	\$617	\$30
	NOTES: 84"W size is ideal for executive layouts or for user's who require additional worksurface space. 72"W top can be combined with different pedestal support options to allow users to personalize their storage needs. Underside of worksurface includes pilot mounting holes for 1½" and L-shaped laminate end panels, and 29⅞"D pedestals. Grain direction runs horizontal (side-to-side). See chart on page 36 for cord management options.					
	Bullet Worksurface					
	84"W x 30"D	HNLBU3084	84	6.3	\$602	\$25
	78"W x 30"D	HNLBU3078	78	6.3	\$573	\$20
	72"W x 30"D	HNLBU3072	72	5.5	\$498	\$20
	66"W x 30"D	HNLBU3066	66	5.5	\$474	\$20
	60"W x 30"D	HNLBU3060	60	4.7	\$441	\$20
	48"W x 30"D	HNLBU3048	54	3.7	\$387	\$15
	NOTES: Applications include U- or L-shaped peninsula configurations and island extensions. Underside of worksurface includes pilot mounting holes for O-leg, T-shaped end panel, 29⅞"D pedestals, 4½" diameter support column, and 2" square post leg. One flat bracket is packaged with each worksurface for applications requiring connection to an adjoining worksurface. Grain direction runs horizontal (side-to-side). Can be used in combination with a 15¾"W or 9½"W x 29⅞"D x 28¼"H modular pedestal to create a freestanding desk. See chart on page 36 for cord management options.					

NOTES:

- ❗ When specifying an 84"W size, cannot use two O-legs; must use another type of support component such as a pedestal.
- ❗ Steel external support channel can be attached to the underside of worksurfaces that are subjected to heavier loads. Channel is recommended to provide extra support on unsupported spans of 54"W or greater or per user preference. Ordered separately from worksurface.
- ❗ If using a 54"W or 60"W floating modesty panel, it is not necessary to specify an external support channel.
- ❗ When using an external support channel under the worksurface, the depth clearance for center drawers and keyboard platforms decreases by 8".
- ❗ See "External Channel (Recommended Use)" chart on page 85.

HOW TO SPECIFY

Select Model Number <div style="border: 1px solid #ccc; padding: 2px; display: flex; gap: 5px;"> HNLBW3684 </div>	Select Edge Profile and Edge Color See page 29 <div style="border: 1px solid #ccc; padding: 2px; display: flex; gap: 5px;"> BH </div>	Select Worksurface Grommet Finish P Black T1 Platinum X No Grommet <div style="border: 1px solid #ccc; padding: 2px; display: flex; gap: 5px;"> P </div>	Select Worksurface Color See page 29 <div style="border: 1px solid #ccc; padding: 2px; display: flex; gap: 5px;"> H </div>
--	--	--	--



CONCINNITY™ Components — Worksurfaces

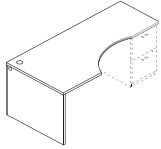

Right-hand model
HNLEEC367224R shown

DESCRIPTION	MODEL	SHIP WEIGHT	CUBE	L1 LIST	L2 UPCHARGES	
					WORKSURFACE	END PANEL
Extended Corner Worksurface						
72"W x 48"D, Right	HNLEEC487224R	130	8.9	\$1039	\$50	\$50
72"W x 48"D, Left	HNLEEC487224L	130	8.9	\$1039	\$50	\$50
72"W x 36"D, Right	HNLEEC367224R	106	6.6	\$860	\$45	\$45
72"W x 36"D, Left	HNLEEC367224L	106	6.6	\$860	\$45	\$45

NOTES: For use in U- or L-shaped layouts. Includes top and long (47"D or 35"D) end panel components. Installation also requires modesty panel and either a 1½" thick end panel or 15¾" x 23⅜"D pedestal support for opposite end; both ordered separately. 72"W x 24/48"D or 48/24"D top is intended for use with 30/48"D or 48/30"D jetty peninsula to create a 2-piece "U" station with a curved cockpit on user's side. 72"W x 24/36"D or 36/24"D size is intended for use with 24"D returns or bridges. Underside of worksurface has pilot mounting holes for 1½" thick end panel and 15¾" x 23⅜"D modular pedestal. Edgebanding on the extended corner worksurface is profiled on the user's side and flat on the back (approach side) and ends. Grain direction runs horizontal (side-to-side).

! One flat bracket is packaged with each 48"D worksurface for applications requiring connection to a 48"D jetty peninsula. For 36"D extended corner worksurface, the flat bracket is shipped with the adjoining return or bridge. See chart on page 36 for cord management options. If grommet option is chosen, the worksurface component will match the color specified; the long end panel grommet color will be black.

NOTES:

- ! When specifying an 84"W size, cannot use two O-legs; must use another type of support component such as a pedestal.
- ! Steel external support channel can be attached to the underside of worksurfaces that are subjected to heavier loads. Channel is recommended to provide extra support on unsupported spans of 54"W or greater or per user preference. Ordered separately from worksurface.
- ! If using a 54"W or 60"W floating modesty panel, it is not necessary to specify an external support channel.
- ! When using an external support channel under the worksurface, the depth clearance for center drawers and keyboard platforms decreases by 8".
- ! See "External Channel (Recommended Use)" chart on page 85.

HOW TO SPECIFY

<p>Select Model Number</p> <p>HNLEEC487224R</p>	<p>Select Edge Profile and Edge Color</p> <p>See page 29</p> <p>BH</p>	<p>Select Worksurface Grommet Finish</p> <p>P Black T1 Platinum X No Grommet</p> <p>X</p>	<p>Select Worksurface Color</p> <p>See page 29</p> <p>H</p>	<p>Select End Panel Color</p> <p>See page 29</p> <p>H</p>
--	---	--	--	--

CONCINNITY™

Components — Supports

GSA SIN 33721 EXCEPT AS NOTED

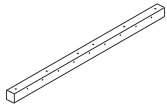

Icon Legend on page 19

**DESCRIPTION****External Support Channel**

72"W for a 78" Worksurface
 66"W for a 72" Worksurface
 60"W for a 66" Worksurface
 54"W for a 60" Worksurface
 48"W for a 54" Worksurface

MODEL**SHIP WEIGHT****CUBE****LIST PRICE**

HLSLZ5SC84	12	0.7	\$110
HLSLZ5SC78	7	0.5	\$110
HLSLZ5SC72	7	0.5	\$110
HLSLZ5SC66	7	0.5	\$101
HLSLZ5SC60	6	0.5	\$98

! Available in Graphite paint only.

! Attaches to underside of worksurface; required for unsupported spans greater than 54"W.

! When specifying a 54"W or 60"W Floating Modesty Panel, it is not necessary to specify an external channel.

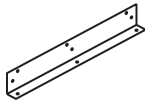

HVPWLBK24 shown

OPEN MARKET

Worksurface Wall Mount Bracket

For 30"
 For 24"

HVPWLBK30

2

0.3

\$83**HVPWLBK24**

2

0.3

\$76

NOTES: Can be used in place of an end panel to support a worksurface. Cannot be used as a support when placing a stack-on storage unit on worksurface over bracket; must have two full-sized floor supports when using stack-on storage. Finish option not required.

SPECIFYING EXAMPLE: HVPWLBK30**DESCRIPTION****Worksurface to Tower Bracket Kit**

18½" long bracket for attaching 24"D worksurface directly to storage tower, wardrobe/bookcase, wardrobe/storage cabinet, storage cabinet/lateral file, storage cabinet, or lateral file.

MODEL**SHIP WEIGHT****CUBE****LIST PRICE BY PAINT GRADE****P1****P2****P3**

HSTB2W1	4	0.6	\$76	\$89	\$100
----------------	---	-----	-------------	-------------	--------------

NOTES: Can be used in place of end panel or O-leg to support worksurfaces.

! Bracket not designed for use as a support if placing Stack-on Storage on worksurface over/above bracket. Two full-sized supports required when using Stack-on Storage.

NOTES:

• Use the worksurface to tower bracket kit to attach worksurfaces to Storage Tower models.

! Depending on your support combination, an external channel may be required for extra support on unsupported spans greater than 54"W.

HOW TO SPECIFY

Select
 Model Number

H L S L Z 5 S C 8 4

HNL Support Options — External Channel (model HLSLZ5SCxx) - Recommended Use

	Support Combination		Worksurface Width											
	Support 1	Support 2	30"	36"	42"	48"	54"	60"	66"	72"	78"	84"	90"	96"
O-LEG ON ONE END	O-Leg	O-Leg	NR	NR	NR	NR	60	66	72	78	84	NA	NA	NA
	O-Leg	9½"W Ped	NR	NR	NR	NR	NR	60	66	72	78	84	NA	NA
	O-Leg	End Bookcase	NA	NR	NR	NR	NR	NR	60	66	72	78	84	NA
	O-Leg	L End Panel	NR	NR	NR	NR	NR	60	66	72	78	84	NA	NA
	O-Leg	15¾"W Ped	NA	NR	NR	NR	NR	NR	NR	60	66	72	78	NA
	O-Leg	18"W Ped	NA	NA	NR	NR	NR	NR	NR	60	66	72	78	84
	O-Leg	30"W Ped	NA	NA	NA	NA	NR	NR	NR	NR	NR	60	66	72
	O-Leg	36"W Ped	NA	NA	NA	NA	NA	NR	NR	NR	NR	NR	60	66
	NARROW PED	9½"W Ped	9½"W Ped	NA	NA	NR	NR	NR	NR	NR	60	66	72	78
9½"W Ped		End Bookcase	NA	NA	NR	NR	NR	NR	NR	60	66	72	78	84
9½"W Ped		L End Panel	NA	NR	NR	NR	NR	NR	60	66	72	78	84	NA
9½"W Ped		15¾"W Ped	NA	NA	NA	NR	NR	NR	NR	NR	60	66	72	78
9½"W Ped		18"W Ped	NA	NA	NA	NR	NR	NR	NR	NR	60	66	72	78
9½"W Ped		30"W Ped	NA	NA	NA	NA	NA	NR	NR	NR	NR	NR	60	66
9½"W Ped		36"W Ped	NA	NA	NA	NA	NA	NA	NR	NR	NR	NR	NR	60
END BOOKCASE PED		End Bookcase	End Bookcase	NA	NA	NR	NR	NR	NR	NR	NR	60	66	72
	End Bookcase	L End Panel	NA	NA	NR	NR	NR	NR	NR	60	66	72	78	84
	End Bookcase	15¾"W Ped	NA	NA	NA	NR	NR	NR	NR	NR	60	66	72	78
	End Bookcase	18"W Ped	NA	NA	NA	NR	NR	NR	NR	NR	NR	60	66	72
	End Bookcase	30"W Ped	NA	NA	NA	NA	NA	NR	NR	NR	NR	NR	60	
	End Bookcase	36"W Ped	NA	NA	NA	NA	NA	NA	NR	NR	NR	NR	NR	
L END PANEL	L End Panel	L End Panel	NA	NR	NR	NR	NR	NR	60	66	72	78	84	NA
	L End Panel	15¾"W Ped	NA	NA	NR	NR	NR	NR	NR	NR	60	66	72	78
	L End Panel	18"W Ped	NA	NA	NA	NR	NR	NR	NR	NR	60	66	72	78
	L End Panel	30"W Ped	NA	NA	NA	NA	NA	NR	NR	NR	NR	NR	60	66
	L End Panel	36"W Ped	NA	NA	NA	NA	NA	NA	NR	NR	NR	NR	NR	60
TWO PEDS	15¾"W Ped	15¾"W Ped	NA	NA	NA	NA	NR	NR	NR	NR	NR	60	66	72
	15¾"W Ped	18"W Ped	NA	NA	NA	NA	NR	NR	NR	NR	NR	60	66	72
	15¾"W Ped	30"W Ped	NA	NA	NA	NA	NA	NR	NR	NR	NR	NR	NR	60
	15¾"W Ped	36"W Ped	NA	NA	NA	NA	NA	NA	NR	NR	NR	NR	NR	60
	18"W Ped	18"W Ped	NA	NR	NA	NA	NR	NR	NR	NR	NR	NR	60	66
	18"W Ped	30"W Ped	NA	NA	NA	NR	NA	NA	NR	NR	NR	NR	NR	60
	18"W Ped	36"W Ped	NA	NA	NA	NA	NA	NA	NR	NR	NR	NR	NR	60
	30"W Ped	30"W Ped	NA	NA	NA	NA	NA	NR	NR	NR	NR	NR	NR	60
	30"W Ped	36"W Ped	NA	NA	NA	NA	NA	NA	NR	NR	NR	NR	NR	60
	36"W Ped	36"W Ped	NA	NA	NA	NA	NA	NA	NR	NR	NR	NR	NR	60
RETURN CONFIGURATION	None	O-Leg	NR	NR	NR	NR	60	66	72	78	84	NA	NA	NA
	None	9½"W Ped	NR	NR	NR	NR	NR	60	66	72	78	84	NA	NA
	None	End Bookcase	NA	NR	NR	NR	NR	NR	60	66	72	78	84	NA
	None	L End Panel	NR	NR	NR	NR	NR	60	66	72	78	84	NA	NA
	None	15¾"W Ped	NA	NR	NR	NR	NR	NR	NR	60	66	72	78	NA
	None	18"W Ped	NA	NA	NR	NR	NR	NR	NR	60	66	72	78	84
	None	30"W Ped	NA	NA	NA	NA	NR	NR	NR	NR	NR	60	66	72
	None	36"W Ped	NA	NA	NA	NA	NA	NR	NR	NR	NR	NR	60	66

NA = Stiffener not applicable due to invalid worksurface width and support combination

NR = Applicable worksurface width and support combination, but stiffener not required

! The chart reference is to be used to complete the model number. It is not the actual length dimension of the external support channel.

CONCINNITY™

Components — Modesty/Back Panels

GSA SIN 33721

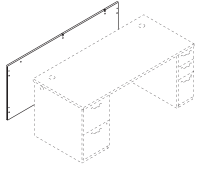

Icon Legend on page 19

**DESCRIPTION****Modesty/Back Panels — Full-Length**

96"W x 27¹/₈"H
 90"W x 27¹/₈"H
 84"W x 27¹/₈"H
 78"W x 27¹/₈"H
 72"W x 27¹/₈"H
 66"W x 27¹/₈"H
 60"W x 27¹/₈"H
 54"W x 27¹/₈"H
 48"W x 27¹/₈"H
 42"W x 27¹/₈"H

MODEL

HNLMP9628
HNLMP9028
HNLMP8428
HNLMP7828
HNLMP7228
HNLMP6628
HNLMP6028
HNLMP5428
HNLMP4828
HNLMP4228

SHIP WEIGHT

62
58
54
50
46
42
38
34
30
26

CUBE

7.2
6.7
6.1
5.5
5.3
4.8
4.4
4.0
3.6
3.2

L1 LIST PRICE

\$430
\$419
\$347
\$308
\$285
\$268
\$243
\$235
\$221
\$204

L2 UPCHARGE

\$25
\$25
\$25
\$20
\$20
\$20
\$20
\$20
\$15
\$15

36"W x 27¹/₈"H Modesty/Pedestal Back Panel
 30"W x 27¹/₈"H Modesty/Pedestal Back Panel

HNLMP3628
HNLMP3028

22
18

2.8
2.4

\$188
\$175

\$12
\$12

Modesty/Back Panels — Short

96"W x 10"H
 90"W x 10"H
 84"W x 10"H
 78"W x 10"H
 72"W x 10"H
 66"W x 10"H
 60"W x 10"H
 54"W x 10"H
 48"W x 10"H
 42"W x 10"H
 36"W x 10"H
 30"W x 10"H

HNLMP9610
HNLMP9010
HNLMP8410
HNLMP7810
HNLMP7210
HNLMP6610
HNLMP6010
HNLMP5410
HNLMP4810
HNLMP4210
HNLMP3610
HNLMP3010

22
21
20
19
18
17
16
15
14
13
12
11

3.0
2.8
2.8
2.3
2.1
1.9
1.8
1.6
1.4
1.3
1.1
0.9

\$430
\$419
\$347
\$308
\$285
\$268
\$243
\$235
\$221
\$204
\$188
\$175

\$15
\$15
\$15
\$12
\$12
\$12
\$12
\$12
\$10
\$10
\$10
\$10

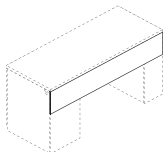

Back View

NOTES: For use with modular worksurface and support components. Component is 3/4" thick. Full-to-floor sizes can be specified with or without grommet; see chart on page 36 for cord management options. For standing-height applications, a worksurface supported by 1 1/8" thick x 41"H laminate end panel(s) and/or 41"H support pedestal(s), the recommended modesty panel length extends 27 1/8" below the underside of the top, leaving 13" of wall access; 9 1/2" and 15 3/4" W x 13"H backs are available to enclose the balance of the pedestal back. Worksurfaces supported by a 1 1/8" thick x 41"H laminate end panel and 41"H support pedestal, or by two 41"H support pedestals, can be used with a 10" modesty panel to increase the amount of wall access, however in this application the pedestal(s) should be positioned against a wall, as there is not a 30 7/8"H panel to cover the back of the pedestal that is exposed below the modesty panel. The 10"H modesty panel is not recommended for use in a standing-height shell, where both supports are 41"H laminate end panels; for this solution use the 27 1/8"H modesty panel. For standing-height applications with the worksurface supported by 41"H O-legs or L-shaped end panels, use the appropriate floating modesty panel size.

NOTES:

- Provide approach-side kneespace privacy for user seated at desks, credenzas, returns, and bridges.
- Full-width laminate panel can be specified in 6" increments from 30"-96"W, and in full-length (27 1/8"H) or short (10"H).
- Formal, full-length, 27 1/8"H models extend from the underside of the worksurface to the floor.
- 10"H sizes allow quick and easy access to wall power outlets.
- 30"W and 36"W x 27 1/8"H are sized to serve as a modesty panel, or pedestal back for respective 30"W and 36"W support storage pedestal models.

! The full-width panel designs are specifically for use when the worksurface supports are two 1 1/8" thick end panels, two support storage pedestals, or one 1 1/8" thick end panel and one support storage pedestal; not for use with O-legs or L-shaped end panels.

HOW TO SPECIFY

Select Model Number H N L M P 7 2 2 8	Select Grommet P Black X No Grommet	Select Laminate Color See page 29
Select Model Number H N L M P 7 2 1 0	Select Laminate Color See page 29	



CONCINNITY™

Components — Modesty/Back Panels

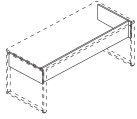

Not available in two-tone laminate

DESCRIPTION	MODEL	SHIP WEIGHT	CUBE	L1 LIST PRICE	L2 UPCHARGE
Modesty Panels for Desks with O-Legs					
68 ³ / ₈ "W x 3/4"D x 10"H — For 72" x 30" Desks	HLAMMP7230	26	2.1	\$289	\$15
56 ³ / ₈ "W x 3/4"D x 10"H — For 60" x 30" Desks	HLAMMP6030	23	1.8	\$264	\$15

NOTES: For use with 60"W or 72"W worksurfaces supported by O-legs. Comprised of three panels: one approach side and one for each end. Length below bottom of worksurface is 10". Steel external support channel (ordered separately) is recommended for unsupported spans greater than 54"W (i.e.: a distance in which there is not a vertical support between the underside of the worksurface and floor). Grain direction is vertical on approach and side panels for 56³/₈"W (all laminate colors) and 68³/₈"W (L1 laminate except Florence Walnut and Kingswood Walnut). Vertical on 27⁵/₈" end panels (all laminate colors). Horizontal on all panels for L2 laminates as well as Florence Walnut and Kingswood Walnut.

Specify: Model.Laminate

SPECIFYING EXAMPLE: HLAMMP7230.N

! \$15 upcharge for L2 laminates. See pages 236-237 for laminate options.

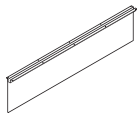

Laminate Floating Modesty Panel	MODEL	SHIP WEIGHT	CUBE	L1 LIST PRICE	L2 UPCHARGE
60"W x 14"H	HLSL6014L	20	1.1	\$250	\$12
54"W x 14"H	HLSL5414L	18	1.1	\$232	\$12
48"W x 14"H	HLSL4814L	16	1.1	\$212	\$12
42"W x 14"H	HLSL4214L	14	0.8	\$193	\$10
36"W x 14"H	HLSL3614L	12	0.8	\$179	\$10
30"W x 14"H	HLSL3014L	10	0.8	\$169	\$10

NOTES: The attachment bracket and modesty panel are packaged separately.

Specify: Model.Laminate.Paint

SPECIFYING EXAMPLE: HLSL3014L.N.P (Black is the only paint option for this model)

! When specifying the 54"W or 60"W Laminate Floating Modesty Panel, it is not necessary to specify an external support channel.

! 30"W and 36"W screens attach with L-brackets, not the external channel.

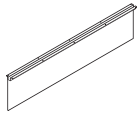

Mixed Material Floating Modesty Panel	MODEL	SHIP WEIGHT	CUBE	L1 LIST PRICE	L2 UPCHARGE
60"W x 14"H	HLSL6014MM	13	3.3	\$1113	N/A
54"W x 14"H	HLSL5414MM	13	3.3	\$974	N/A
48"W x 14"H	HLSL4814MM	11	2.6	\$898	N/A
42"W x 14"H	HLSL4214MM	9	2.3	\$811	N/A
36"W x 14"H	HLSL3614MM	8	2.0	\$726	N/A
30"W x 14"H	HLSL3014MM	8	2.0	\$676	N/A

NOTES: The attachment bracket and modesty panel are packaged separately.

Specify: Model.Mixed Material.Paint

SPECIFYING EXAMPLE: HLSL3014MM.FT01.P (Frosted Translucent mixed material and Black paint are the only options for this model)

! When specifying the 54"W or 60"W Mixed Material Floating Modesty Panel, it is not necessary to specify an external support channel.

NOTES:

- Floating panel options attach under worksurfaces and are available in laminate or mixed (frosted translucent) material. The modesty panel and attachment bracket are packaged separately.
- If using a 54"W or 60"W floating modesty panel, it is not necessary to specify an external support channel.
- When using a floating modesty panel under the worksurface, the depth clearance for center drawers and keyboard platforms decreases by 8".
- The full width/half-height and full-to-floor/full-height panels are filler options designed only for use on 60", 66", and 72"W x 29¹/₂"H, double, 15³/₄"W, pedestal desks and credenzas that are specified/built with modular components.

HOW TO SPECIFY

Select Model Number

HLSL3014MM.

Select Mixed Material

FT01 Frosted Translucent

FT01

CONCINNITY™

Components — Modesty/Back Panels

GSA SIN 33721

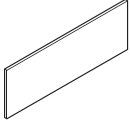
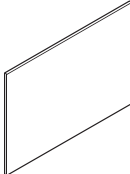

Icon Legend on page 19

	DESCRIPTION	MODEL	SHIP WEIGHT	CUBE	L1 LIST PRICE	L2 UPCHARGE
	Full Width/Half-Height Laminate Modesty Panel					
	40"W x 14"H, for use with 72" desks	HLSL4014LM	29	2.4	\$199	\$10
	34"W x 14"H, for use with 66" desks	HLSL3414LM	23	1.9	\$190	\$10
	28"W x 14"H, for use with 60" desks	HLSL2814LM	19	1.6	\$185	\$10
	NOTES: Filler piece that can only be used between the following supports: two 15¾"W modular pedestals, two 15¾"W L-shaped end panels, or one 15¾"W modular pedestal and one 15¾"W L-shaped end panel. Attachment brackets included.					
	Full-to-Floor/Full-Length Laminate Modesty Panel					
	40"W x 28½"H, for use with 72" desks	HLSL4028LM	44	3.6	\$306	\$12
	34"W x 28½"H, for use with 66" desks	HLSL3428LM	38	3.2	\$290	\$12
	28"W x 28½"H, for use with 60" desks	HLSL2828LM	33	2.7	\$247	\$12
	NOTES: Filler piece that can only be used between the following supports: two 15¾"W modular pedestals, two 15¾"W L-shaped end panels, or one 15¾"W modular pedestal and one 15¾"W L-shaped end panel. Attachment brackets included.					

NOTES:

- Floating panel options attach under worksurfaces and are available in laminate or mixed (frosted translucent) material. The modesty panel and attachment bracket are packaged separately.
- If using a 54"W or 60"W floating modesty panel, it is not necessary to specify an external support channel.
- When using a floating modesty panel under the worksurface, the depth clearance for center drawers and keyboard platforms decreases by 8".
- The full width/half-height and full-to-floor/full-height panels are filler options designed only for use on 60", 66", and 72"W x 29½"H, double, 15¾"W, pedestal desks and credenzas that are specified/built with modular components.

HOW TO SPECIFYSelect
Model Number

H L S L 2 8 1 4 L M .

Select
Laminate Color

See page 29

N

CONCINNITY™ MODESTY/BACK PANELS

HNL Floating Modesty Panel — HSLxx14L/MM — Selection Guide														
	Support Combination		Worksurface Width											
	Support 1	Support 2	30"	36"	42"	48"	54"	60"	66"	72"	78"	84"	90"	96"
O-LEG ON ONE END	O-Leg	O-Leg	NA	NA	36	42	48	54	60	60	60	NA	NA	NA
	O-Leg	9½"W Ped	NA	NA	NA	30	36	42	48	54	60	60	NA	NA
	O-Leg	End Bookcase	NA	NA	NA	30	36	42	48	54	60	60	60	NA
	O-Leg	L End Panel	NA	NA	NA	36	42	48	54	60	60	60	NA	NA
	O-Leg	15¾"W Ped	NA	NA	NA	NA	30	36	42	48	54	60	60	NA
	O-Leg	18"W Ped	NA	NA	NA	NA	30	36	42	48	54	60	60	60
	O-Leg	30"W Ped	NA	NA	NA	NA	NA	NA	30	36	42	48	54	60
	O-Leg	36"W Ped	NA	NA	NA	NA	NA	NA	NA	30	36	42	48	54
NARROW PED	9½"W Ped	9½"W Ped	NA	NA	NA	NA	30	36	42	48	54	60	60	60
	9½"W Ped	End Bookcase	NA	NA	NA	NA	30	36	42	48	54	60	60	60
	9½"W Ped	L End Panel	NA	NA	NA	NA	30	36	42	48	54	60	60	NA
	9½"W Ped	15¾"W Ped	NA	NA	NA	NA	NA	30	36	42	48	54	60	60
	9½"W Ped	18"W Ped	NA	NA	NA	NA	NA	30	36	42	48	54	60	60
	9½"W Ped	30"W Ped	NA	NA	NA	NA	NA	NA	NA	NA	30	36	48	48
	9½"W Ped	36"W Ped	NA	NA	NA	NA	NA	NA	NA	NA	30	36	42	48
END BOOKCASE PED	End Bookcase	End Bookcase	NA	NA	NA	NA	NA	30	36	42	48	54	60	60
	End Bookcase	L End Panel	NA	NA	NA	NA	30	36	36	48	54	60	60	60
	End Bookcase	15¾"W Ped	NA	NA	NA	NA	NA	30	36	42	48	54	60	60
	End Bookcase	18"W Ped	NA	NA	NA	NA	NA	NA	30	36	42	48	54	60
	End Bookcase	30"W Ped	NA	NA	NA	NA	NA	NA	NA	NA	30	36	42	48
	End Bookcase	36"W Ped	NA	NA	NA	NA	NA	NA	NA	NA	NA	30	36	42
L END PANEL	L End Panel	L End Panel	NA	NA	NA	NA	36	36	48	54	60	60	60	NA
	L End Panel	15¾"W Ped	NA	NA	NA	NA	NA	30	36	42	48	54	60	60
	L End Panel	18"W Ped	NA	NA	NA	NA	NA	30	36	42	48	54	60	60
	L End Panel	30"W Ped	NA	NA	NA	NA	NA	NA	NA	30	36	42	48	54
	L End Panel	36"W Ped	NA	NA	NA	NA	NA	NA	NA	NA	30	36	42	48
TWO PEDS	15¾"W Ped	15¾"W Ped	NA	NA	NA	NA	NA	NA	30	36	42	48	54	60
	15¾"W Ped	18"W Ped	NA	NA	NA	NA	NA	NA	30	36	36	48	54	60
	15¾"W Ped	30"W Ped	NA	NA	NA	NA	NA	NA	NA	NA	30	36	42	48
	15¾"W Ped	36"W Ped	NA	NA	NA	NA	NA	NA	NA	NA	30	36	42	48
	18"W Ped	18"W Ped	NA	NA	NA	NA	NA	NA	NA	30	36	42	48	54
	18"W Ped	30"W Ped	NA	NA	NA	NA	NA	NA	NA	NA	NA	30	36	42
	18"W Ped	36"W Ped	NA	NA	NA	NA	NA	NA	NA	NA	NA	NA	30	36
	30"W Ped	30"W Ped	NA	NA	NA	NA	NA	NA	NA	NA	NA	NA	NA	30
	30"W Ped	36"W Ped	NA	NA	NA	NA	NA	NA	NA	NA	NA	NA	NA	NA
	36"W Ped	36"W Ped	NA	NA	NA	NA	NA	NA	NA	NA	NA	NA	NA	NA
HT ADJ BASE	Height Adjustable Electric Base (model HHAB3S2L)		NA	NA	NA	42	48	54	60	60	NA	NA	NA	NA
PENINSULA	Support Column	T End Panel	NA	NA	NA	30	30	36	42	48	54	60	60	60
	Support Column	9½"W Ped	NA	NA	NA	NA	NA	30	36	42	48	54	60	60
	Support Column	15¾"W Ped	NA	NA	NA	NA	NA	NA	30	36	42	48	54	60
	Support Column	18"W Ped	NA	NA	NA	NA	NA	NA	30	36	42	48	54	60
	Support Column	30"W Ped	NA	NA	NA	NA	NA	NA	NA	NA	30	36	42	48
	Support Column	36"W Ped	NA	NA	NA	NA	NA	NA	NA	NA	NA	30	36	42
RETURN CONFIGURATION	None	O-Leg	NA	NA	36	42	48	54	60	60	60	NA	NA	NA
	None	9½"W Ped	NA	NA	NA	30	36	42	48	54	60	60	NA	NA
	None	End Bookcase	NA	NA	NA	30	36	42	48	54	60	60	60	NA
	None	L End Panel	NA	NA	36	36	42	48	54	60	60	60	NA	NA
	None	15¾"W Ped	NA	NA	NA	NA	30	36	42	48	54	60	60	NA
	None	18"W Ped	NA	NA	NA	NA	30	36	42	48	54	60	60	60
	None	30"W Ped	NA	NA	NA	NA	NA	NA	30	36	42	48	54	60
	None	36"W Ped	NA	NA	NA	NA	NA	NA	NA	30	36	42	48	60

NA = Floating Modesty Panel not applicable for use with worksurface width and support combination

CONCINNITY™

Components — Supports

GSA SIN 33721

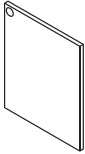
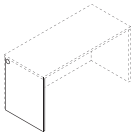
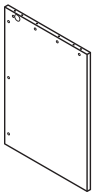

Icon Legend on page 19

	DESCRIPTION	MODEL	SHIP WEIGHT	CUBE	L1 LIST PRICE	L2 UPCHARGE
 HNLEP2428R shown	1 1/8" Laminate End Panels — For 29 1/2"H 1 1/8"W x 35"D x 28 1/2"H for 36"D, Right 1 1/8"W x 35"D x 28 1/2"H for 36"D, Left	HNLEP3628R HNLEP3628L	39 39	2.8 2.8	\$260 \$260	\$20 \$20
	1 1/8"W x 29 1/8"D x 28 1/2"H for 30"D, Right 1 1/8"W x 29 1/8"D x 28 1/2"H for 30"D, Left	HNLEP3028R HNLEP3028L	32 32	2.3 2.3	\$229 \$229	\$15 \$15
 HNLEP2428L shown	1 1/8"W x 23 1/8"D x 28 1/2"H for 24"D, Right 1 1/8"W x 23 1/8"D x 28 1/2"H for 24"D, Left	HNLEP2428R HNLEP2428L	22 22	1.9 1.9	\$204 \$204	\$10 \$10
	1 1/8" Laminate End Panels — For 42"H 1 1/8"W x 29 1/8"D x 41"H for 30"D, Right 1 1/8"W x 29 1/8"D x 41"H for 30"D, Left	HNLEP3041R HNLEP3041L	47 47	3.2 3.2	\$259 \$259	\$20 \$20
 HNLEP2441R shown	1 1/8"W x 23 1/8"D x 41"H for 24"D, Right 1 1/8"W x 23 1/8"D x 41"H for 24"D, Left	HNLEP2441R HNLEP2441L	37 37	2.6 2.6	\$243 \$243	\$15 \$15

NOTES: Supports the end of a component worksurface where there is no modular pedestal. 1 1/8" Laminate End Panels must be used with a full-length (27 7/8"H) or short (10"H) modesty/back panel; ordered separately, see page 86. The depth of an end panel is 3/4" less than the depth of the worksurface, to accommodate the modesty/back panel. Handed design (left and right models). Bottom of end panel is edgebanded for added strength and to seal out moisture. Applications include — For the non-pedestal end of single pedestal desks or credenzas utilizing modular storage components. For returns that do not have a modular storage pedestal to support the worksurface. For extended corner units that do not utilize a 15 3/4"W x 23 1/8"D modular storage pedestal to support the 24"D worksurface dimension. For building desk or credenza shells comprised of a worksurface top and modesty/back panel components, and left and right end panel. Available in a woodgrain or solid laminate color only. Can be specified with or without grommet; see chart on page 36 for cord management options. If grommet option is chosen, the color is black only.

NOTES:

! 1 1/8" Laminate End Panels must be used with a full-length (27 7/8"H) or short (10"H) modesty/back panel; ordered separately, see page 86.

HOW TO SPECIFY

Select Model Number <input type="text" value="HNLEP2428R"/>	Select Grommet <input type="radio"/> Black <input checked="" type="radio"/> No Grommet <input type="text" value="X"/>	Select Laminate Color <input type="text" value="H"/> See page 29
---	---	--

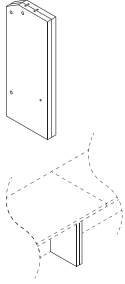

DESCRIPTION	MODEL	SHIP WEIGHT	CUBE	L1	L2
				LIST PRICE	UPCHARGE
Kneespace Clearance End Panels 1 1/8"W x 11 1/4"D x 41"H for 24"D, 2 pk	HNLEP1141	25	2.8	\$285	\$10
1 1/8"W x 11 1/4"D x 28 1/2"H for 24"D, 2 pk	HNLEP1128	25	2.0	\$233	\$10

NOTES: Creates additional kneespace for the user. Two 1 1/8"W x 11 1/4"D laminate end panels, one left, one right; sized to support two adjoining, contiguous 24"D worksurfaces. Can be specified with worksurfaces at time of installation or ordered as replacement for two side-by-side 1 1/8"W x 23"D end panels. Available in 28 1/2" and 41"H. Can be used to connect up to three credenzas in line (2 kits). Not designed for use with returns. Allows conversion of units currently in the field; European fasteners make installation quick and easy. Cord routing notch in top back of each panel. Includes two 1 1/8" thick panels; European fastening hardware; flat connector bracket; self-tapping wood screws for ganging credenza to adjacent worksurface; and adjustable leveling glides. Can be specified in a woodgrain or solid laminate color only; not in a two-tone combination.

SPECIFYING EXAMPLE: HNLEP1128.H

HOW TO SPECIFY

<p>Select Model Number</p> <p>HNLEP1128</p>	<p>Select Grommet</p> <p>P Black X No Grommet</p> <p>X</p>
--	---

CONCINNITY™

Components — Supports

GSA SIN 33721



Icon Legend on page 19

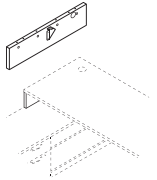

HNLEP307L shown

DESCRIPTION	MODEL	SHIP WEIGHT	CUBE	L1 LIST PRICE	L2 UPCHARGE
Laminate End Panel — 7”H Support for Worksurfaces					
1½”W x 30”D x 7”H, Right	HNLEP307R	7	0.7	\$133	\$10
1½”W x 30”D x 7”H, Left	HNLEP307L	7	0.7	\$133	\$10
1½”W x 24”D x 7”H, Right	HNLEP247R	6	0.7	\$133	\$10
1½”W x 24”D x 7”H, Left	HNLEP247L	6	0.7	\$133	\$10

NOTES: Specifically for layered surface applications; used to support a 29½”H component worksurface over a 21½”H low credenza unit. 1½” thick. Handed design (left and right models). Includes cord routing notch. Bottom of end panel is edgebanded for added strength and to seal out moisture. Attaches to underside of worksurface via cam fasteners and L-bracket; attaches to top of low credenza with double-sided tape. Can be specified in a woodgrain or solid laminate color only. For 7”H metal O-leg support see page 94.

SPECIFYING EXAMPLE: HNLEP307R.H

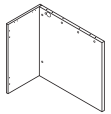

HNLLEP3028R shown

DESCRIPTION	MODEL	SHIP WEIGHT	CUBE	L1 LIST PRICE	L2 UPCHARGE
Laminate L-Shaped End Panels — For 29½”H					
15¾”W x 30”D x 28½”H, Right	HNLLEP3028R	38	4.3	\$368	\$15
15¾”W x 30”D x 28½”H, Left	HNLLEP3028L	38	4.3	\$368	\$15
15¾”W x 24”D x 28½”H, Right	HNLLEP2428R	32	2.8	\$332	\$15
15¾”W x 24”D x 28½”H, Left	HNLLEP2428L	32	2.8	\$332	\$15

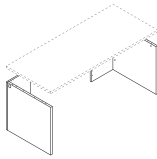

HNLLEP3028R and HNLLEP3028L shown

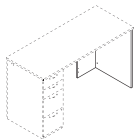
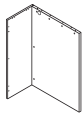

HNLLEP3041R shown



DESCRIPTION	MODEL	SHIP WEIGHT	CUBE	L1 LIST PRICE	L2 UPCHARGE
Laminate L-Shaped End Panels — For 42”H					
15¾”W x 30”D x 41”H, Right	HNLLEP3041R	55	4.3	\$407	\$20
15¾”W x 30”D x 41”H, Left	HNLLEP3041L	55	4.3	\$407	\$20
15¾”W x 24”D x 41”H, Right	HNLLEP2441R	47	2.8	\$364	\$20
15¾”W x 24”D x 41”H, Left	HNLLEP2441L	47	2.8	\$364	\$20

NOTES: Supports the end of a component worksurface where there is no modular pedestal. Provides easy, open access to wall electrical outlets. For configurations requiring a modesty panel, options include a laminate floating modesty panel or a mixed material floating modesty panel — see page 87. Tops and bottoms of panels are edgebanded. Two pieces; 1½” end panel and ¾” back panel. Ships simple assembly. Can be specified in a woodgrain or solid laminate color only; not available in a two-tone combination. See chart on page 36 for cord management options. If grommet option is chosen for the end panel, the color is black only.

SPECIFYING EXAMPLE: HNLLEP2428R.X.H

HOW TO SPECIFY

Select Model Number

H N L E P 3 0 7 R .

Select Laminate Color

See page 29

H

Select Model Number

H N L L E P 3 0 2 8 R .

Select Grommet

P Black
X No Grommet

X

Select Laminate Color

See page 29

H



CONCINNITY™ Components — Supports

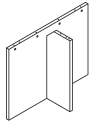

DESCRIPTION

MODEL

SHIP WEIGHT

CUBE

**L1
LIST PRICE**

**L2
UPCHARGE**

Laminate T-Shaped End Panels — For 29½”H

11⅝”W x 35⅞”D x 28½”H

HNLTEP3628

45

3.7

\$375

\$20

11⅝”W x 29⅞”D x 28½”H

HNLTEP3028

39

3.3

\$353

\$20

11⅝”W x 23⅞”D x 28½”H

HNLTEP2428

33

2.9

\$332

\$20

NOTES: Supports the end of a component worksurface where there is no modular pedestal. Available in 24”, 30”, and 36”D x 28½”H. Two 1⅝” thick pieces; one end and one brace panel. Cord routing notch in brace panel. Non-handed. Ships ; simple assembly. Can be specified in a woodgrain or solid laminate color only; not available in a two-tone combination.

SPECIFYING EXAMPLE: HNLTEP3628.H

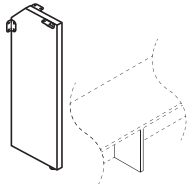

Support Brace — For 29½”H

1⅝”W x 10½”D x 28½”H

HNL11SUPP

11

0.9

\$149

\$10

NOTES: Minimizes worksurface deflection by providing added internal support under 24”D tops with an unsupported span of 54” or wider (distance for which there is no panel, leg, or pedestal support component). Not for use as an end panel. 11”D size provides kneespace clearance. Attaches with brackets to both the underside of the worksurface top and either a conventional full-length or 10” laminate modesty panel; not for use with O-leg or L-shaped end panel supports. 1⅝” thick. Cord routing notch in brace panel. Can be specified in a woodgrain or solid laminate color only.

SPECIFYING EXAMPLE: HNL11SUPP.H

HOW TO SPECIFY

Select Model Number

H N L 1 1 S U P P . H

Select Laminate Color

See page 29

H

CONCINNITY™

Components — Supports

GSA SIN 33721

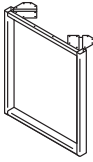
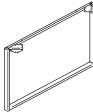
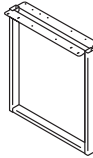
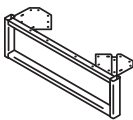
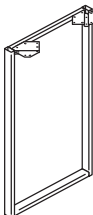
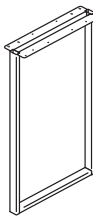

Icon Legend on page 19

	DESCRIPTION	MODEL	SHIP WEIGHT	CUBE	LIST PRICE BY PAINT GRADE		
					P1	P2	P3
	O-Leg 30"D x 28½"H 24"D x 28½"H	HLSL3028O HLSL2428O	19 17	5.4 3.7	\$352 \$316	\$356 \$320	\$372 \$336
	NOTES: Ship fully assembled, 1/pack. Non-handed. IMPORTANT: The O-leg attachment bracket interferes with placement of 28¾"H mobile pedestals, preventing them from being positioned directly next to (flush with) the O-leg. Box/file mobile pedestal (model HNL2116MBF) can be positioned along side the O-leg. SPECIFYING EXAMPLE: HLSL2428O.T1						
	Double-Depth O-Leg Support for Worksurfaces 60"D x 28½"H 48"D x 28½"H	HLSL6028O HLSL4828O	19 18	8.7 7.0	\$665 \$597	\$673 \$605	\$685 \$617
	NOTES: Ship fully assembled, 1/pack. Non-handed. 48"D and 60"D sizes span back-to-back 24"D and 30"D worksurfaces, respectively.						
	O-Leg Shared Support for Worksurfaces 30"D x 28½"H 24"D x 28½"H	HLSL3028SL HLSL2428SL	19 17	5.4 3.7	\$438 \$394	\$442 \$398	\$458 \$414
	NOTES: Ship fully assembled, 1/pack. Non-handed. ! Specify paint only. SPECIFYING EXAMPLE: HLSL2028SL.T1						
	O-Leg Support for Low Credenzas 30"D x 7"H 24"D x 7"H	HLSL307O HLSL247O	7 6	1.0 1.0	\$271 \$213	\$275 \$217	\$291 \$233
	NOTES: Ship fully assembled, 1/pack. Non-handed. For 7"H laminate support see page 92. ! Specify paint only. SPECIFYING EXAMPLE: HLSL207O.T1						
	Standing-Height O-Leg Support for Worksurfaces 30"D x 41"H 24"D x 41"H	HLSL3041O HLSL2441O	17 16	6.5 5.3	\$474 \$424	\$480 \$430	\$494 \$444
	NOTES: Ship fully assembled, 1/pack. Non-handed.						
	Standing-Height O-Leg Shared Support for Worksurfaces 30"D x 41"H 24"D x 41"H	HLSL3041SL HLSL2441SL	17 16	6.5 5.3	\$529 \$478	\$535 \$484	\$549 \$498
	NOTES: Ship fully assembled, 1/pack. Non-handed. For use with two 24"D or 30"D worksurfaces positioned side-by-side along the depth dimension.						

NOTES:

- Open frame, metal design.
- O-leg ships fully assembled with mounting hardware.
- O-leg glides have 2" adjustability.
- Will have 6" overhang when using 30"D O-legs with a 36"D worksurface.
- Shared O-legs create a cleaner aesthetic in all applications where two legs are used side-by-side.

! O-legs may only be attached to worksurfaces, not storage units.

! O-leg installation requires 6" of clearance from the worksurface end.

! For use with worksurfaces up to 78"W. When using an 84"W or wider worksurface, cannot use two O-legs; must use one 15¼" or wider pedestal for the other support.

HOW TO SPECIFY

Select Model Number	Select Paint Color
HLSL3028O	See page 171
T1	

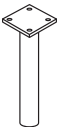

	DESCRIPTION	MODEL	SHIP WEIGHT	CUBE	LIST PRICE
	Support Column 4½" Diameter. Specify: HPC190X.P. Black only.	HPC190X	12 Ⓞ	1.0	\$161
	Support Column 4½" Diameter. Specify: HPC191X.X. Available in Silver only.	HPC191X	12 Ⓞ	1.0	\$161
NOTES: For peninsula or island extension worksurface application.					

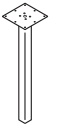
	DESCRIPTION	MODEL	SHIP WEIGHT	CUBE	LIST PRICE BY PAINT GRADE	
					P1	P2
	Post Leg Base 28½"H x 2" square	HLSL28P	15	1.0	\$292	\$296
	NOTES: Can only be used as the outbound support in a peninsula or island extension worksurface application. Glides have 2" of adjustability. Ship 1/pack. SPECIFYING EXAMPLE: HLSL28P.T1					

NOTES:

- All bases allow tops to sit at 29½" from the floor with glides half-way seated.

Height Adjustable Base

- 3-Stage column design.
- Frame rises from 23¾" to 49¼" for a sit-to-stand desk option.
- Ships complete with a pre-assembled motor.
- Base telescopes to accommodate any worksurface between 48"W and 72"W.
- Accommodates rectangular worksurfaces between 24"D x 48"W and 30"D x 72"W.
- Standard height adjustable control ships with base.
- Dynamic load capacity when worksurface is moving is 300 lbs.
- Optional Memory Control allows preset worksurface heights for consistency. Ships separately.
- Silver finish matches any neutral HON paint or finish color.
- Tops and bases are ordered and sold separately.

Post and T-Leg Bases

- Both glides and casters attach to the foot easily without tools for assembly.
- Bases specified with casters include two locking and two non-locking casters.
- Bases specified with glides have four adjustable glides, which adjust 1".
- When post legs are used with 18"W tops, post leg to be specified with glides only.

- ! Support column must be specified for worksurfaces used as peninsulas or as an island extension.
- ! Post leg can only be used to support peninsula, not as primary supports for a top.

HOW TO SPECIFY

<p>Select Model Number</p> <p>H P C 1 9 0 X .</p>	<p>Select Paint Color</p> <p>See page 171</p> <p>T 1</p>
--	---

CONCINNITY™

Components — Supports

GSA SIN 33721

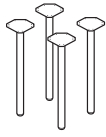

Icon Legend on page 19

**DESCRIPTION****Post Leg Base (Includes 4 Post Legs)**

24"D and 30"D Worksurfaces up to 72"W

MODEL**HMBPOST****SHIP WEIGHT**

18

CUBE

2.3

LIST PRICE**\$352**

NOTES: For 54" and 60" worksurfaces, use one external channel, centered between user and approach sides. For 66" and 72"W worksurfaces, use two external channels; if no grommets, locate the channels 3" from user and approach sides; if grommets are in the worksurface, locate channels 3" from user and 6" from approach sides.

1¾" diameter Post Leg Base with glide (HMBPOST.G); qty. 4; for 30" to 72"W x 24"D and 48" to 72"W x 30"D tops

1¾" diameter Post Leg Base with casters (HMBPOST.C); qty. 4; for 30" to 72"W x 24"D and 48" to 72"W x 30"D tops

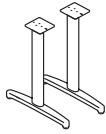
**Fixed Height T-Leg Base (Includes 2 T-legs)**

For 24"D and 30"D Worksurfaces up to 72"W

HMBTLEG24

14

3.6

\$418

NOTES: Use external channel when space between the two legs is 54"W or greater. Center the channel between approach and user sides. See model listing on page 84.

Fixed Height T-Leg Base with glide (HMBTLEG24.G); qty. 2; for 24" and 30"D tops up to 72"W; adjustable glides have 1" range

Fixed Height T-Leg Base with casters (HMBTLEG24.C); qty. 2; for 24" and 30"D tops up to 72"W; two locking and two non-locking casters

NOTES:

- All bases allow tops to sit at 29½" from the floor with glides half-way seated.

Post and T-Leg Bases

- Both glides and casters attach to the foot easily without tools for assembly.
- Bases specified with glides have four adjustable glides, which adjust 1".
- When post legs are used with 18"W tops, post leg to be specified with glides only.

ⓘ Support column must be specified for worksurfaces used as peninsulas or as an island extension.

ⓘ Post leg can only be used to support peninsula, not as primary supports for a top.

HOW TO SPECIFY**Select Model Number**

HMBTLEG24

Select Glide/Caster Option**G** Glide**C** Caster

18"D tops are not available in Concinnity™

G

Select Paint Color

See page 29

\$20 upcharge per model, for Metallic paint

T1



Icon Legend on page 19

CONCINNITY™ Height Adjustable Bases

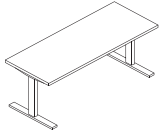

Base shown with work surface attached.

DESCRIPTION

Coordinate™ Height Adjustable Base – 3 Stage
24”D Feet and Worksurface Brackets

MODEL

SHIP WEIGHT

CUBE

LIST PRICE

HHAB3S2L

67

2.4

\$1120

NOTES: Support option for 24” and 30” rectangle worksurfaces. Worksurfaces are ordered separately, see model listing on pages 80-81.

⚠ Telescoping horizontal frame will extend just over 2” from underside of the worksurface.

⚠ Coordinate™ Height Adjustable Bases not compatible with 36”D rectangular worksurfaces.

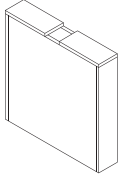

Not available in two-tone laminate.

SIN 33721

Shroud for Height Adjustable Base

5 1/8”W x 26”D x 26 1/4”H for Base with 30”D Top

HLAMSHB30

39

3.7

\$848

NOTES: Decorative laminate enclosure covers the Coordinate™ metal leg and foot. Lowest base adjustment position when the shroud is installed is 29 1/2”H; memory controller must be set at that height to avoid interference. For use with standard 10500 Series™, Concinnity™, and Voi® rectangle worksurfaces, 48-72”W x 30”D, supported by Height Adjustable Base models HHAB3S2L or HHAB2S2L. For height adjustable desks requiring a modesty panel, options include: 14”H laminate (HLSLXX14L) or mixed material (HLSLXX14MM) floating modesty panels, laminate full length (HNLMPXX28) or short (HNLMPXX10) modesty/back panel plus external support channel (HLSLZ5SCXX). External support channel attachment screws and modesty/back panel cover caps are included in the shroud hardware pack. External support channel size recommendation, specific to work surface attached to Height Adjustable Base with optional laminate full-length or short modesty back/panel (HNLMPXX28/10) see below. Ships one per carton. To conceal both metal legs on the Height Adjustable Base order two.

Specify: Model.Laminate; see pages 236-237.

SPECIFYING EXAMPLE: HLAMSHB30.N

⚠ The Height Adjustable Base must be reset at the time of installation, after every loss of power, if the unit is not functioning properly, or if the legs are uneven. To reset the base requires removing the laminate shroud(s), as well as the full-length modesty panel if one is being used, then adjusting the base to its lowest position. Disassembly of the shroud is quick and easy.

⚠ \$25 upcharge for L2 laminates.

Worksurface Width	Modesty/Back Panel Width	External Support Channel
72”W	72”W	HLSLZ5SC78
66”W	66”W	HLSLZ5SC72
60”W	60”W	HLSLZ5SC66
54”W	54”W	HLSLZ5SC60
48”W	48”W	HLSLZ5SC54

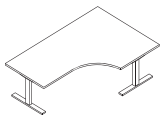

Base shown with work surface attached.

Coordinate™ 3-Leg Height Adjustable Base – 3 Stage

24”D Feet and Worksurface Brackets

HHAB3S3L

91

3.6

\$1896

NOTES: Supports two rectangular worksurfaces to create a height adjustable L-shaped configuration. The 3-leg base supports corner coves or two-piece worksurfaces 41”-72”W x 35”-72”L x 23 1/4”-30”D. 48”W 120 degree corner worksurfaces are also supported. When using two worksurfaces, the connection between the two must be over the telescoping frame. Supports weight capacity of 375 lbs. (excluding work surface weight).

⚠ Telescoping horizontal frame will extend just over 2” from underside of the work surface.

NOTES:

Height Adjustable Base

- 3-Stage column design.
- Frame rises from 21 1/8” to 47 3/4” for a sit-to-stand desk option.
- Ships complete with a pre-assembled motor.
- Comes standard with one-touch, four memory controller with digital display; no specification needed, available in black finish only.
- Base telescopes to accommodate any work surface between 48”W and 72”W.
- Accommodates rectangular worksurfaces between 24”D x 48”W and 30”D x 72”W.
- Standard height adjustable control ships with base.
- Dynamic load capacity when work surface is moving is 250 lbs.
- Tops and bases are ordered and sold separately.
- For additional information see page 581.
- **HON 5-Year Limited Warranty.**

⚠ Worksurfaces used with Coordinate™ Height Adjustable Bases should have 1” perimeter gap on each side to provide clearance between other furniture. Failure to do so risks injury or product damage (not covered by warranty).

HOW TO SPECIFY

<p>Select Model Number</p> <p>HHAB3S2L.</p>	<p>Select Finish</p> <p>P71 Black P8L Nickel PDB White</p> <p>P8L</p>
--	--

CONCINNITY™ Components — Privacy Screens

GSA SIN 33721



Icon Legend on page 19

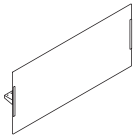

DESCRIPTION

Above/Below Privacy Screen

- 60"W x 28"H
- 54"W x 28"H
- 48"W x 28"H
- 42"W x 28"H
- 36"W x 28"H
- 30"W x 28"H

MODEL

- HLSL2860**
- HLSL2854**
- HLSL2848**
- HLSL2842**
- HLSL2836**
- HLSL2830**

SHIP WEIGHT

CUBE

LIST PRICE

- | | | |
|---|-----|---------------|
| 9 | 8.6 | \$1397 |
| 9 | 8.6 | \$1389 |
| 8 | 8.2 | \$1192 |
| 6 | 6.3 | \$1120 |
| 6 | 6.4 | \$1106 |
| 6 | 6.4 | \$800 |

NOTES: Attachment bracket extends 2" into top and underside of worksurface. Screen is frosted translucent acrylic. All brackets are platinum (no need to specify). Extends 13" above and 13" below worksurface.

❗ See page 99 for the "Above-Below Privacy Screen — HLSL28xx — Selection Guide".

❗ Available in Frosted Translucent Acrylic ONLY HLSL2830.FT01.

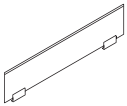

Above Privacy Screen

- 60"W x 13"H
- 54"W x 13"H
- 48"W x 13"H
- 42"W x 13"H
- 36"W x 13"H
- 30"W x 13"H

- HLSL1260**
- HLSL1254**
- HLSL1248**
- HLSL1242**
- HLSL1236**
- HLSL1230**

- | | | |
|----|-----|--------------|
| 24 | 2.9 | \$453 |
| 22 | 2.9 | \$421 |
| 20 | 2.3 | \$394 |
| 18 | 2.3 | \$344 |
| 15 | 1.8 | \$308 |
| 13 | 1.5 | \$279 |

NOTES: Attachment requires 1" clear space/overhang on the underside of the worksurface. Screen is frosted glass. All brackets are platinum (no need to specify).

❗ Available in Frosted Glass ONLY HLSL1230.G.

❗ Above only privacy screen clamps onto worksurface and cannot be installed where support storage will be attached.

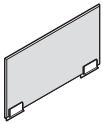

Above Frosted Polymer (Side) Privacy Screen

- 36"W x 13"H
- 30"W x 13"H
- 24"W x 13"H

- HLSL1236FS**
- HLSL1230FS**
- HLSL1224FS**

- | | | |
|----|-----|--------------|
| 19 | 1.9 | \$398 |
| 16 | 1.6 | \$356 |
| 14 | 1.4 | \$329 |

NOTES: Attach to top and side of worksurface with adhesive banding. Platinum color brackets are intended to be attached between users sitting side-by-side. Brackets create a 1/8" separation between adjacent worksurfaces.

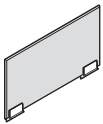

Above Frosted Glass (Side) Privacy Screen

- 36"W x 13"H
- 30"W x 13"H
- 24"W x 13"H

- HLSL1236GS**
- HLSL1230GS**
- HLSL1224GS**

- | | | |
|----|-----|--------------|
| 20 | 1.9 | \$331 |
| 18 | 1.6 | \$297 |
| 16 | 1.4 | \$274 |

NOTES: Attach to top and side of worksurface with adhesive banding. Platinum color brackets are intended to be attached between users sitting side-by-side. Brackets create a 1/8" separation between adjacent worksurfaces.

NOTES:

- Ships complete with attachment brackets.
- All brackets are Platinum.
- Above Privacy Screen attaches to top of worksurface.
- Above and below privacy screen extends 13" above and 13" below the worksurface.
- ❗ Above screens must attach to edgeband and top of surface.
- ❗ Screens cannot be used with T-mold on series such as tables. Screens can only attach to edgeband. Surfaces must be cleaned prior to adhering the screen and must be left to cure for 24 hours without touching for best adhesion.

HOW TO SPECIFY

Select Model Number

HLSL2830 .

HLSL1230 .

Select Mixed Material

FT01 Frosted Translucent Acrylic
Specified for Above/Below Privacy Screens only

G Frosted Glass
Specified for Above Privacy Screens only

FT01

G

Select Model Number

HLSL1224FS .

HLSL1224GS .

Select Mixed Material

FT01 Frosted Translucent Acrylic
Specified for Above Screen models HLSL1224FS-HLSL1236FS only

G Frosted Glass
Specified for Above Screen models HLSL1224GS-HLSL1236GS only

FT01

G

CONCINNITY™ PRIVACY SCREENS

HNL Above-Below Privacy Screen — HLSL28xx — Selection Guide

	Support Combination		Worksurface Width											
	Support 1	Support 2	30"	36"	42"	48"	54"	60"	66"	72"	78"	84"	90"	96"
O-LEG ON ONE END	O-Leg	O-Leg	NA	30	36	42	48	54	60	60	60	NA	NA	NA
	O-Leg	9½"W Ped	NA	NA	30	36	42	48	54	60	60	60	NA	NA
	O-Leg	End Bookcase	NA	NA	NA	30	36	42	48	54	60	60	60	NA
	O-Leg	L End Panel	NA	NA	NA	36	42	48	54	60	60	60	NA	NA
	O-Leg	15¾"W Ped	NA	NA	NA	30	36	42	48	54	60	60	60	NA
	O-Leg	18"W Ped	NA	NA	NA	NA	30	36	42	48	54	60	60	60
	O-Leg	30"W Ped	NA	NA	NA	NA	NA	NA	30	36	42	48	54	60
	O-Leg	36"W Ped	NA	NA	NA	NA	NA	NA	NA	30	36	42	48	54
NARROW PED	9½"W Ped	9½"W Ped	NA	NA	NA	NA	30	36	42	48	54	60	60	60
	9½"W Ped	End Bookcase	NA	NA	NA	NA	30	36	42	48	54	60	60	60
	9½"W Ped	L End Panel	NA	NA	NA	30	36	42	48	48	60	60	60	NA
	9½"W Ped	15¾"W Ped	NA	NA	NA	NA	NA	30	36	42	48	54	60	60
	9½"W Ped	18"W Ped	NA	NA	NA	NA	NA	30	36	42	48	54	60	60
	9½"W Ped	30"W Ped	NA	NA	NA	NA	NA	NA	NA	30	36	42	48	54
	9½"W Ped	36"W Ped	NA	NA	NA	NA	NA	NA	NA	NA	30	36	42	48
END BOOKCASE PED	End Bookcase	End Bookcase	NA	NA	NA	NA	30	36	42	48	54	60	60	60
	End Bookcase	L End Panel	NA	NA	NA	NA	30	36	42	48	54	60	60	60
	End Bookcase	15¾"W Ped	NA	NA	NA	NA	NA	30	36	42	48	54	60	60
	End Bookcase	18"W Ped	NA	NA	NA	NA	NA	30	36	42	48	54	60	60
	End Bookcase	30"W Ped	NA	NA	NA	NA	NA	NA	NA	30	36	42	48	54
	End Bookcase	36"W Ped	NA	NA	NA	NA	NA	NA	NA	NA	30	36	42	48
L END PANEL	L End Panel	L End Panel	NA	NA	NA	30	36	42	48	54	60	60	60	NA
	L End Panel	15¾"W Ped	NA	NA	NA	NA	30	36	42	48	54	60	60	60
	L End Panel	18"W Ped	NA	NA	NA	NA	NA	30	36	42	48	54	60	60
	L End Panel	30"W Ped	NA	NA	NA	NA	NA	NA	NA	30	36	42	48	54
	L End Panel	36"W Ped	NA	NA	NA	NA	NA	NA	NA	NA	30	36	42	48
TWO PEDS	15¾"W Ped	15¾"W Ped	NA	NA	NA	NA	NA	NA	30	36	42	48	54	60
	15¾"W Ped	18"W Ped	NA	NA	NA	NA	NA	NA	30	36	42	48	54	60
	15¾"W Ped	30"W Ped	NA	NA	NA	NA	NA	NA	NA	NA	30	36	42	48
	15¾"W Ped	36"W Ped	NA	NA	NA	NA	NA	NA	NA	NA	NA	30	36	42
	18"W Ped	18"W Ped	NA	NA	NA	NA	NA	NA	30	36	42	48	48	60
	18"W Ped	30"W Ped	NA	NA	NA	NA	NA	NA	NA	NA	30	36	42	48
	18"W Ped	36"W Ped	NA	NA	NA	NA	NA	NA	NA	NA	NA	30	36	42
	30"W Ped	30"W Ped	NA	NA	NA	NA	NA	NA	NA	NA	NA	NA	30	36
	30"W Ped	36"W Ped	NA	NA	NA	NA	NA	NA	NA	NA	NA	NA	NA	30
	36"W Ped	36"W Ped	NA	NA	NA	NA	NA	NA	NA	NA	NA	NA	NA	NA
HT ADJ BASE	Height Adjustable Base (model HHAB3S2L)		NA	NA	NA	42	48	54	60	60	NA	NA	NA	NA
RETURN CONFIGURATION	None	O-Leg	NA	30	36	42	48	54	60	60	60	NA	NA	NA
	None	9½"W Ped	NA	NA	30	36	42	48	54	60	60	60	NA	NA
	None	End Bookcase	NA	NA	NA	30	36	42	48	54	60	60	60	NA
	None	L End Panel	NA	NA	30	36	42	48	54	60	60	60	NA	NA
	None	15¾"W Ped	NA	NA	NA	30	36	36	48	54	60	60	60	NA
	None	18"W Ped	NA	NA	NA	NA	30	36	42	48	54	60	60	60
	None	30"W Ped	NA	NA	NA	NA	NA	NA	30	36	42	48	54	60
	None	36"W Ped	NA	NA	NA	NA	NA	NA	NA	30	36	42	48	54

NA = Above-Below Screen not applicable for use with worksurface width and support combination

CONCINNITY™ COMPONENTS — SUPPORTS

SUPPORT STORAGE PEDESTALS — 28½”H



- Non-handed, interchangeable design reconfigures easily.
- For use with component top and modesty/back panels or pedestal top and back panels.
 - Pedestals are not fully enclosed and require a component top/worksurface and modesty/back panel or a pedestal back, both of which must be ordered separately.
 - Pedestal’s front and side panels are finished.
- The pedestal depth dimension is less than the like-size depth of the component top, to accommodate addition of a modesty/back panel.
 - 29½”D pedestals can be used under 30” or 36”D worksurfaces; 23½”D pedestals can be used under 24” or 30”D worksurfaces.
 - When specifying a 29½”D pedestal with ¾” modesty panel under a 36”D worksurface, or a 23½”D pedestal with a ¾” modesty panel under a 30”D worksurface, there will be a 6” approach side overhang.
- Bottom of side panels are edgebanded for added strength and to seal out moisture.
- Drawers:
 - Operate on steel ball-bearing suspensions to ensure smooth, quiet, long-lasting operation; full extension allows easy access to contents.
 - Fronts are edgebanded on all four sides.
 - Feature 5-sided construction for added strength and easy alignment or replacement of drawer fronts.

- Interchangeable core removable locks are located on front of all modular storage products, except the storage cabinet.
- Finish of lock is determined by, and aligned with, the handle finish specified.
- Locks feature a removable cylinder that can be interchanged as needed; allows users to access all furniture pieces in an office with a single key for convenience and security. Makes re-keying quick and easy. Keyed alike cores must be ordered separately by specification of the key number (removable lock core kit models available in Black [model HF23B] or Satin [model HF23S]).
- Ship fully assembled.
- Chassis and drawer front colors are specified separately; can be selected with common woodgrain or solid laminate color, or with different, complementary chassis and drawer/door colors.
- See chart on page 36 for cord management options. If the pedestal grommet option is chosen, two cutouts, one per end/side panel, each with a black plastic cap, are included.

SUPPORT STORAGE PEDESTALS — 41”H STANDING-HEIGHT

- Same as above except — not to be used freestanding; top and back are not enclosed.
 - Rear of pedestal can be enclosed with a full, 40¾”H back panel or with a 27⅞”H modesty panel combined with a lower, 13”H pedestal back component. Pedestal back and modesty panel must be ordered separately.

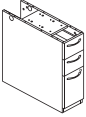
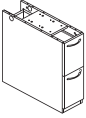

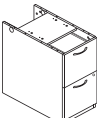
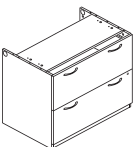
DESCRIPTION	MODEL	SHIP WEIGHT	CUBE	L1 LIST	L2 UPCHARGES	
					CHASSIS	FRONTS
 <p>Narrow Box/Box/File Pedestal 9½"W x 29⅞"D x 28½"H 9½"W x 23⅞"D x 28½"H</p> <p>NOTES: Efficient, space saving design for smaller footprints. Three locking drawers; two box (supply) drawers, one for files. File drawer has high sides to accept hanging folders; hangrails are included for side-to-side letter or legal filing. Pedestal's top and back are open and require top and back panel components — ordered separately. See chart on page 36 for cord management options. Ships fully assembled. SPECIFYING EXAMPLE: HNL291028PBBF.E.X.H.H</p>	HNL291028PBBF	64	10.6	\$772	\$25	\$10
	HNL231028PBBF	53	8.6	\$690	\$20	\$10
 <p>Narrow File/File Pedestal 9½"W x 29⅞"D x 28½"H 9½"W x 23⅞"D x 28½"H</p> <p>NOTES: Efficient, space saving design for smaller footprints. Two locking file drawers. Drawers have high sides to accept hanging folders; hangrails are included for side-to-side letter or legal filing. Pedestal's top and back are open and require top and back panel components — ordered separately. See chart on page 36 for cord management options. Ships fully assembled. SPECIFYING EXAMPLE: HNL291028PFF.E.X.H.H</p>	HNL291028PFF	69	10.6	\$772	\$25	\$10
	HNL231028PFF	54	10.6	\$690	\$20	\$10
 <p>Box/Box/File Pedestal 15¾"W x 29⅞"D x 28½"H 18"W x 23⅞"D x 28½"H 15¾"W x 23⅞"D x 28½"H</p> <p>NOTES: Three locking drawers; two box (supply) drawers, one for files. File drawer has high sides to accept hanging folders; hangrails are included for side-to-side letter or legal filing; and front-to-back for letter filing. Pedestal's top and back are open and require top and back panel components — ordered separately. See chart on page 36 for cord management options. Ships fully assembled. SPECIFYING EXAMPLE: HNL291628PBBF.E.X.H.H</p>	HNL291628PBBF	76	10.6	\$782	\$25	\$10
	HNL231828PBBF	72	9.8	\$785	\$20	\$10
	HNL231628PBBF	69	8.6	\$714	\$20	\$10
 <p>File/File Pedestal 15¾"W x 29⅞"D x 28½"H 18"W x 23⅞"D x 28½"H 15¾"W x 23⅞"D x 28½"H</p> <p>NOTES: Two locking file drawers. Drawers have high sides to accept hanging folders; hangrails are included for side-to-side letter or legal filing; and front-to-back for letter filing. Pedestal's top and back are open and require top and back panel components — ordered separately. See chart on page 36 for cord management options. Ships fully assembled. SPECIFYING EXAMPLE: HNL291628PFF.E.X.H.H</p>	HNL291628PFF	78	10.6	\$782	\$25	\$10
	HNL231828PFF	72	9.8	\$785	\$20	\$10
	HNL231628PFF	70	8.6	\$714	\$20	\$10
 <p>Lateral File Pedestal 36"W x 23⅞"D x 28½"H 30"W x 23⅞"D x 28½"H</p> <p>NOTES: Two locking file drawers; drawers include hangrails to accept folders in letter or legal size. For use under 24"D rectangle worksurface. Widths can also span depth dimension of respective 30" or 36"D rectangle worksurface. Anti-tip design includes mechanical interlock to inhibit the extension of more than one drawer at a time. Pedestal's top and back are open and require top and back panel components — ordered separately. See chart on page 36 for cord management options. Ships fully assembled. SPECIFYING EXAMPLE: HNL233628PLF.E.X.H.H</p>	HNL233628PLF	134	18.4	\$1056	\$40	\$20
	HNL233028PLF	115	15.0	\$964	\$35	\$20

NOTES:

- 29⅞"D pedestals can be used under 30" or 36"D worksurfaces; 23⅞"D pedestals can be used under 24" or 30"D worksurfaces.
- Drawers operate on steel ball-bearing suspensions to ensure smooth, quiet, long-lasting operation; full extension allows easy access to contents.
- Interchangeable core removable locks allow users to access all furniture pieces in an office with a single key for convenience and security. Makes re-keying quick and easy.
- See chart on page 36 for cord management options. If the pedestal grommet option is chosen, two cutouts, one per end/side panel, each with a black plastic cap, are included.

ⓘ Pedestal tops and backs are open and require top and back panel components — ordered separately.

ⓘ 9½"W pedestals are not designed to be used independently in a stand-alone application.

HOW TO SPECIFY

<p>Select Model Number</p> <p>H N L 2 9 1 0 2 8 P B B F .</p>	<p>Select Handle</p> <p>A Cylinder – Satin B Cylinder – Black C Canopy – Satin D Canopy – Black E Loop – Satin F Loop – Black</p> <p>E .</p>	<p>Select Grommet</p> <p>P Black X No Grommet</p> <p>X .</p>	<p>Select Chassis Color</p> <p>See page 29</p> <p>H .</p>	<p>Select Drawer Front Color</p> <p>See page 29</p> <p>H</p>
--	---	---	--	---

CONCINNITY™

Components — Supports

GSA SIN 33721

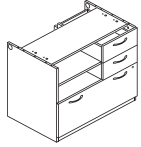

Icon Legend on page 19

**DESCRIPTION****Shelf/Box/Box/Lateral File Pedestal**

36"W x 23 1/8"D x 28 1/2"H

30"W x 23 1/8"D x 28 1/2"H

MODEL**HNL233628PSL****HNL233028PSL****SHIP WEIGHT**

145

126

CUBE

18.4

15.0

L1 LIST**\$1245****\$1221****L2 UPCHARGES****CHASSIS****\$40****\$35****FRONTS****\$20****\$20**

NOTES: Versatile unit features an open shelf and three drawers; two for supplies and one for files. For use under 24"D rectangle worksurface. Widths can also span depth dimension of respective 30" or 36"D rectangle worksurface. Box (supply) drawers are located on the right and open shelves on the left. All drawers lock. Pedestal's top and back are open and require top and back panel components — ordered separately. See chart on page 36 for cord management options. Ships fully assembled.

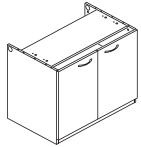
SPECIFYING EXAMPLE: HNL233628PSL.E.X.H.H**Storage Cabinet Pedestal**

36"W x 23 1/8"D x 28 1/2"H

30"W x 23 1/8"D x 28 1/2"H

HNL233628PSC**HNL233028PSC**

104

91

18.4

15.0

\$810**\$782****\$40****\$35****\$20****\$20**

NOTES: One adjustable shelf, which adjusts in 2 1/2" increments. For use under 24"D rectangle worksurface. Widths can also span depth dimension of respective 30" or 36"D rectangle worksurface. Doors are non-locking. Pedestal's top and back are open and require top and back panel components — ordered separately. See chart on page 36 for cord management options. Ships fully assembled.

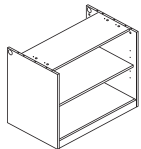
SPECIFYING EXAMPLE: HNL233628PSC.E.X.H.H**Bookcase Pedestal**

36"W x 23 1/8"D x 28 1/2"H

30"W x 23 1/8"D x 28 1/2"H

HNL233628PBK**HNL233028PBK**

82

73

18.4

15.0

\$712**\$695****\$40****\$35****N/A****N/A**

NOTES: Two shelves; bottom of unit plus one adjustable shelf, which adjusts in 2 1/2" increments. For use under 24"D rectangle worksurface. Widths can also span depth dimension of respective 30" or 36"D rectangle worksurface. Pedestal's top and back are open and require top and back panel components — ordered separately. See chart on page 36 for cord management options. Ships fully assembled.

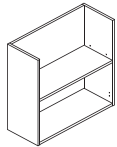
SPECIFYING EXAMPLE: HNL233628PBK.X.H**Bookcase End Support**

12"W x 36"D x 28 1/2"H

12"W x 30"D x 28 1/2"H

12"W x 24"D x 28 1/2"H

HNL123628BKE**HNL123028BKE****HNL122428BKE**

48

48

41

11.0

10.2

7.4

\$534**\$507****\$481****\$25****\$20****\$20****N/A****N/A****N/A**

NOTES: Two shelves; bottom of unit plus one adjustable shelf, which adjusts in 1 1/4" increments. Designed to span the depth dimension of 24", 30", or 36"D rectangle worksurface; shelves can be oriented facing outwards, or inwards towards the user's kneespace. Includes fully finished back. Ships with two (2) extra L-brackets for applications requiring attachment of a laminate modesty panel; the panel brackets to the back of the bookcase end support. Modesty panel specified should be 12" less than the worksurface width. Open top; for use under worksurface only — ordered separately. Ships fully assembled.

SPECIFYING EXAMPLE: HNL123628BKE.H**NOTES:**

- 23 1/8"D pedestals can be used under 24" or 30"D worksurfaces.
- Drawers operate on steel ball-bearing suspensions to ensure smooth, quiet, long-lasting operation; full extension allows easy access to contents.
- Interchangeable core removable locks allow users to access all furniture pieces in an office with a single key for convenience and security. Makes re-keying quick and easy.
- See chart on page 36 for cord management options. If the pedestal grommet option is chosen, two cutouts, one per end/side panel, each with a black plastic cap, are included.

! Pedestal tops and backs are open and require top and back panel components — ordered separately.

HOW TO SPECIFY

Select Model Number	Select Handle	Select Grommet	Select Chassis Color	Select Drawer Front Color
A Cylinder – Satin B Cylinder – Black C Canopy – Satin D Canopy – Black E Loop – Satin F Loop – Black	P Black X No Grommet	See page 29	See page 29	
H N L 2 3 3 6 2 8 P S L .	E .	X .	H .	H



Icon Legend on page 19

CONCINNITY™ Components — Supports

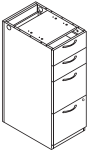
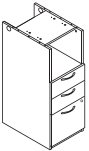
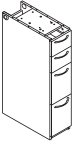
	DESCRIPTION	MODEL	SHIP WEIGHT	CUBE	L1 LIST	L2 UPCHARGES	
						CHASSIS	FRONTS
	Box/Box/File/File Pedestal 15¾"W x 29⅞"D x 41"H	HNL291641PBBFF	114	14.7	\$1602	\$45	\$10
	15¾"W x 23⅞"D x 41"H	HNL231641PBBFF	102	11.9	\$1503	\$40	\$10
	NOTES: Four drawers: two box (supply) and two file. File drawer has high sides to accept hanging folders; hangrails are included for side-to-side letter or legal filing; and front-to-back for letter filing. The two box drawers do not lock. Pedestal's top and back are open and require top and back panel components — ordered separately. See chart on page 36 for cord management options. Ships fully assembled. SPECIFYING EXAMPLE: HNL291641PBBFF.E.X.H.H						
	Shelf/Box/Box/File Pedestal 15¾"W x 29⅞"D x 41"H	HNL291641PSBBF	99	14.7	\$1602	\$45	\$10
	15¾"W x 23⅞"D x 41"H	HNL231641PSBBF	89	11.9	\$1503	\$40	\$10
	NOTES: Open shelf over three drawers: two box (supply) and one file. Interior dimensions of the open storage area are: 14⅞"W x 28¼"D x 12¼"H for the 29⅞"D pedestal. 14⅞"W x 22¼"D x 12¼"H for the 23⅞"D pedestal. File drawer has high sides to accept hanging folders; hangrails are included for side-to-side letter or legal filing; and front-to-back for letter filing. All drawers lock. Pedestal's top and back are open and require top and back panel components — ordered separately. See chart on page 36 for cord management options. Ships fully assembled. SPECIFYING EXAMPLE: HNL291641PSBBF.E.X.H.H						
	Narrow Box/Box/File/File Pedestal 9½"W x 29⅞"D x 41"H	HNL291041PBBFF	88	14.7	\$1410	\$45	\$20
	9½"W x 23⅞"D x 41"H	HNL231041PBBFF	79	11.9	\$1322	\$40	\$20
	NOTES: Efficient, space saving design for smaller footprints. Four drawers: two box (supply) and two file. File drawers have high sides to accept hanging folders; hangrails are included for side-to-side letter or legal filing. When used in a double pedestal configuration under a 60" and 48"W worksurface, provides 41" and 29" of kneespace width, respectively. The two box drawers do not lock. Pedestal's top and back are open and require top and back panel components — ordered separately. See chart on page 36 for cord management options. Ships fully assembled. SPECIFYING EXAMPLE: HNL291041PBBFF.E.X.H.H						

NOTES:

- Pedestals for standing-height workstations.
- 29⅞"D pedestals can be used under 30" or 36"D worksurfaces; 23⅞"D pedestals can be used under 24" or 30"D worksurfaces.
- Drawers operate on steel ball-bearing suspensions to ensure smooth, quiet, long-lasting operation; full extension allows easy access to contents.
- See chart on page 36 for cord management options. If the pedestal grommet option is chosen, two cutouts, one per end/side panel, each with a black plastic cap, are included.

- ! Pedestal tops and backs are open and require top and back panel components — ordered separately.
- ! 9½"W pedestals are not designed to be used independently in a stand-alone application.

HOW TO SPECIFY

<p>Select Model Number</p> <p>H N L 2 9 1 6 4 1 P B B F F .</p>	<p>Select Handle</p> <p>A Cylinder – Satin B Cylinder – Black C Canopy – Satin D Canopy – Black E Loop – Satin F Loop – Black</p> <p>E .</p>	<p>Select Grommet</p> <p>P Black X No Grommet</p> <p>X .</p>	<p>Select Chassis Color</p> <p>See page 29</p> <p>H .</p>	<p>Select Drawer Front Color</p> <p>See page 29</p> <p>H .</p>
--	---	---	--	---

CONCINNITY™

Components — Pedestal Tops

GSA SIN 33721



Icon Legend on page 19

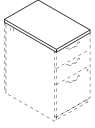

DESCRIPTION	MODEL	SHIP WEIGHT	CUBE	L1	L2
				LIST PRICE	UPCHARGE
Pedestal Tops					
15¾"W x 30"D	HNLPT3016	16	1.4	\$231	\$10
18"W x 24"D	HNLPT2418	15	1.3	\$216	\$10
15¾"W x 24"D	HNLPT2416	13	1.2	\$216	\$10

NOTES: Component is 1½" thick. Underside of top includes pilot mounting holes for pedestals. Grain direction on 15¾" and 18"W pedestal tops runs horizontal (side-to-side). Component tops for 30" and 36"W pedestals are listed with rectangle worksurface sizes. Grain direction on 30" and 36"W pedestal tops can be specified horizontal (side-to-side) or vertical (front-to-back). For tri-oval and beaded edge options, there is a shaped profile on the user and approach sides, and a flat edge on the ends.

ⓘ For modular pedestals used in freestanding applications; not compatible when pedestal is positioned under a worksurface.

ⓘ 9½"W pedestals are not designed to be used independently in a freestanding application, so 9½"W tops are not available to order.

HOW TO SPECIFY

Select
Model Number

H N L P T 3 0 1 6 .

Select
Edge Profile and Edge Color

See page 29

B H .

Select
Top Color

See page 29

H



CONCINNITY™

Components — Pedestal Back Panels

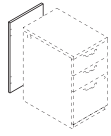
**DESCRIPTION****MODEL****SHIP WEIGHT****CUBE****L1 LIST PRICE****L2 UPCHARGE****Full Back Panels — For 28½”H Pedestals**

18”W x 27⅞”H

HNLBP1828

11

1.5

\$149**\$10**

15¾”W x 27⅞”H

HNLBP1628

10

1.3

\$133**\$10**

9½”W x 27⅞”H

HNLBP1028

6

0.9

\$125**\$10**

NOTES: Encloses the rear of 28½”H modular support pedestals, which come standard with an open, unfinished back. For use when a support storage pedestal is positioned under a 29½”H worksurface and a conventional worksurface width x 27⅞”H modesty/back panel is not specified to cover the back of the pedestal. Examples of when to use a 27⅞” pedestal back include: A worksurface supported by an O-leg on one end and support pedestal on the other, with open wall access; or a worksurface with an O-leg and pedestal support flanking a floating modesty panel. Can be specified in a woodgrain or solid laminate color only. For 30” and 36”W pedestals, use the respective modesty/pedestal back panel size, see page 86.

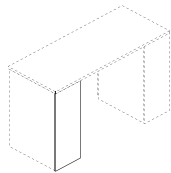
SPECIFYING EXAMPLE (9½”, 15¾”, 18”W): HNLBP1028.H

Back View

Full Back Panels — For 41”H Pedestals

15¾”W x 40⅜”H

HNLBP1641

15

1.8

\$153**\$15**

9½”W x 40⅜”H

HNLBP1041

9

1.2

\$139**\$15**

NOTES: Encloses the rear of 41”H modular support pedestals, which come standard with an open, unfinished back. For use when a support storage pedestal is positioned under a 42”H worksurface and no full-width, 27⅞”H laminate modesty and low, 13”H pedestal back panel are specified. Examples of when to use a 40⅜” pedestal back include: A worksurface supported by an O-leg on one end and support pedestal on the other, with open wall access; or a worksurface with an O-leg and pedestal support flanking a floating modesty panel. Can be specified in a woodgrain or solid laminate color only.

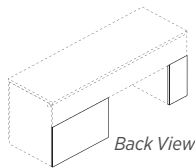
SPECIFYING EXAMPLE: HNLBP1641.H

Back View

Shown with HNLB3018 and HNLB1018

Low Back Panels — For 28½”H Pedestals

36”W x 18”H

HNLB3618

15

1.9

\$149**\$15**

30”W x 18”H

HNLB3018

12

1.6

\$149**\$15**

18”W x 18”H

HNLB1818

7

1.0

\$133**\$15**

15¾”W x 18”H

HNLB1618

6

0.9

\$127**\$10**

9½”W x 18”H

HNLB1018

4

0.6

\$119**\$10**

NOTES: Encloses the rear of 28½”H modular support pedestals when positioned under a 29½”H worksurface with a full-width, 10” laminate modesty panel. The modesty panel extends down from the underside of the worksurface to cover the upper back portion of the pedestal, the lower panel component encloses the remainder of the pedestal back. When used in combination, the 10” modesty and pedestal low back panels fully conceal the rear of the pedestal. The pedestal low back panel is only for use when a modular pedestal is used in conjunction with a worksurface with a 10” laminate modesty panel and the customer wants/needs to fully enclose the back section of the pedestal. Can be specified in a woodgrain or solid laminate color only.

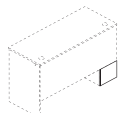

Back View

Low Back Panels — For 41”H Pedestals

15¾”W x 13”H

HNLB1613

4

0.7

\$127**\$10**

9½”W x 13”H

HNLB1013

3

0.5

\$119**\$10**

NOTES: Encloses the rear of 41”H modular support pedestals when positioned under a 42”H worksurface with a full-width, 27⅞” laminate modesty panel. The modesty panel extends down from the underside of the worksurface to cover the upper back portion of the pedestal, the lower panel component encloses the remainder of the pedestal back. When used in combination, the 27⅞” modesty and pedestal low back panels fully conceal the rear of the pedestal. The pedestal low back panel is only for use when a modular pedestal is used in conjunction with a worksurface with a 27⅞” laminate modesty panel and the customer wants/needs to fully enclose the back section of the pedestal. Can be specified in a woodgrain or solid laminate color only.

HOW TO SPECIFY**Select Model Number**

H N L P B 1 8 2 8

Select Laminate Color

See page 29

H

Select Model Number

H N L L B 3 6 1 8

Select Laminate Color

See page 29

H



Refer to page 106 for Center Drawer compatibility information

DESCRIPTION	MODEL	SHIP WEIGHT	CUBE	L1 LIST PRICE	L2 UPCHARGE
Laminate Center Drawer 26" x 15 ³ / ₈ "	H1526	12 Ⓞ	1.2	\$198	\$15
22" x 15 ³ / ₈ "	H1522	11 Ⓞ	1.1	\$184	\$15

• 12" drawer extension (3/4).
 • Inside drawer dimension for H1526: 22⁷/₈"W x 15¹/₂"D x 1¹/₂"H.
 • Inside drawer dimension for H1522: 18⁷/₈"W x 15¹/₂"D x 1¹/₂"H.
 • Minimum clearance for mounting H1526: 27¹/₄"W x 18¹/₂"D compatible with 72"W x 36"D, 66"W x 30"D, 60"W x 30"D Double Pedestal Desks, 72"W x 24"D, 66"W x 24"D, 60"W x 24"D Credenza w/Kneespace, 48"W x 24"D Return
 • Minimum clearance for mounting H1522: 22³/₄"W x 18¹/₂"D compatible with 72"W x 36"D, 66"W x 30"D, 60"W x 30"D Double Pedestal Desks, 72"W x 36"D, 66"W x 30"D Single Pedestal Desks, Bullet and P-shaped Peninsulas, 72"W x 24"D, 66"W x 24"D, 60"W x 24"D Credenza w/Kneespace, 72"W x 24"D, 66"W x 24"D Single Pedestal Credenzas, 48"W x 24"D, 42"W x 24"D Returns

NOTES: Specify laminate for drawer. Model H1522 or H1022 can be used on peninsulas with modesty panel, model HPC180W. Laminate center drawers include pencil tray. For center drawer laminate colors, see page 29.

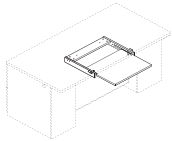

DESCRIPTION	MODEL	SHIP WEIGHT	CUBE	L1 LIST PRICE	L2 UPCHARGE
Collaborative Desk Shelf 25"W x 23"D x 2 ¹ / ₂ "H	HNLCDSEHF	18	1.5	\$345	\$20

NOTES: Convenient slide-out shelf on approach-side of desk provides workspace for guests. For use with 72"W x 36"D breakfront desk designs — see listings on page 43 — or with 60" or wider worksurface, supported by pedestals, and no modesty panel. Minimum clearance for mounting: 28"W x 19³/₄"D. Fully extended shelf dimensions: 24"W x 19"D. Shelf extends 12³/₈". ³/₄" thick. Not compatible on desks with under surface center drawer or keyboard platform attached. Can be specified in a woodgrain or solid laminate color only.

! Collaborative desk shelf for use with 72"W x 36"D breakfront, floating modesty panel desk designs or with 60" or wider worksurface, supported by pedestals, and no modesty panel.

SPECIFYING EXAMPLE: HNLCDSEHF.H

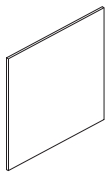

DESCRIPTION	MODEL	SHIP WEIGHT	CUBE	LIST PRICE
Wall Mount 36" W x 35 ¹ / ₄ "H	HNL3636TB	20	2.9	\$300
30"W x 35 ¹ / ₄ "H	HNL3630TB	16	2.9	\$256
36"W x 48⁵/₈"H	HNL4936TB	27	5.5	\$334
30"W x 48 ⁵ / ₈ "H	HNL4930TB	22	3.7	\$290

NOTES: For a list of standard fabrics, see pages 25-26. For a complete list of fabrics, please go to hon.com/fabricsandfinishes. When positioned above 29¹/₂"H floor-standing storage, the sizes align with overhead storage height options. Can be positioned side-by-side with corresponding wall mount sizes. Easy to install; includes mounting hardware. Attaches to wall with horizontally mounted, interlocking Z-clip brackets. For the space directly below stack-on and wall mount storage cabinets, use the 18"H models listed on Pricer pages 59 and 65.

SPECIFYING EXAMPLE: HNL3636TB.APN15

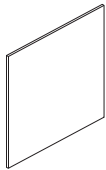

DESCRIPTION	MODEL	SHIP WEIGHT	CUBE	LIST PRICE
Wall Mount 36"W x 35¹/₄" H	HNL3636WB	16	2.9	\$204
30"W x 35 ¹ / ₄ "H	HNL3630WB	14	2.9	\$191
36"W x 48⁵/₈"H	HNL4936WB	22	5.5	\$251
30"W x 48 ⁵ / ₈ "H	HNL4930WB	20	3.7	\$231

NOTES: Smooth, white, magnetic surface. Metal material produces clear graphics and cleans easily. Compatible for use with dry- or wet-erase markers. When positioned above 29¹/₂"H floor-standing storage, the sizes align with overhead storage height options. Can be positioned side-by-side with corresponding wall mount sizes. Easy to install; includes mounting hardware. Attaches to wall with horizontally mounted, interlocking Z-clip brackets.

SPECIFYING EXAMPLE: HNL3636WB

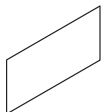

DESCRIPTION	MODEL	SHIP WEIGHT	CUBE	LIST PRICE
36"W x 15"D	HLSL1536SOMB	8	1.0	\$179
30"W x 15"D	HLSL1530SOMB	6	1.0	\$132

NOTES: laminate material with black edges, no frame. Adheres to laminate doors. Includes double-sided tape. No specification necessary.

HOW TO SPECIFY

Select Model Number

Select Laminate Color

See page 29

H N L C D S H E L F . H

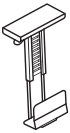
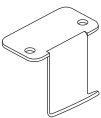

Icon Legend on page 19

	DESCRIPTION	MODEL	SHIP WEIGHT	CUBE	LIST PRICE
	<p>CPU Holder</p> <ul style="list-style-type: none"> Vertically mounts to underside of worksurface. 360° swivel. Supports up to 55 lbs. Height adjustable from 16" to 22" below worksurface. Width adjustable to accept units from 3¼" to 6". <p>NOTES: Arms fold back to post to allow more desktop room. Arms feature double extension, allowing 20"+ of back and forth movement. Cable management on both pole and arm assemblies. Counterbalance adjustment provides stability for monitors up to 17.6 lbs per arm. Made of high quality aluminum alloy material.</p> <p>⚠ Silver finish only, no specification needed.</p>	HCPU *	16 Ⓢ	0.5	\$259
	<p>Back Pack Hook (10 per carton)</p> <p>12"W x 14½"D x 1½"H</p> <p>NOTES: Assembly: attaches to bottom of desk with (2) screws, included.</p> <p>⚠ Available in Platinum Metallic finish only, no specification needed.</p>	HCLA65	10 Ⓢ	0.1	\$94

NOTES:

* De-emphasized.

HOW TO SPECIFY

Select Model Number

H
C
P
U



Black only

SIN 33721

DESCRIPTION**MODEL****SHIP WEIGHT****CUBE****LIST PRICE****Field Installable Grommet — For 2½" Diameter Hole****HFLDGRMT**

0.1 Ⓢ

0.01

\$32

- Intended for use in tops and end panels to route/hide cords and in modesty panels to facilitate reaching wall electrical outlets.
- Grommet is field installable.
- Requires a 2½" diameter hole saw and drill for installation (not included).
- Grommet shape is round.
- Includes grommet cap and sleeve.
- Grommet cap measures 3" diameter and includes a ¾" diameter cord access hole.
- Grommet sleeve measures 2½" O.D. x ¾" thick.
- Includes instructions to locate grommet position for desks, credenzas, returns, and bridges.

! Black Finish

SPECIFYING EXAMPLE: HFLDGRMT

SIN 33721

Field Installable Grommet — For 3" Diameter Hole**HFLDGRMT3**

0.1 Ⓢ

0.3

\$32

- Intended for use in tops and end panels to route/hide cords and in modesty panels to facilitate reaching wall electrical outlets.
- Grommet is field installable.
- Requires a 3" diameter hole saw and drill for installation (not included).
- Grommet shape is round.
- Includes grommet cap and sleeve.
- Grommet outside dimensions measures 3½" diameter and includes two cord access holes.
- Grommet sleeve measures 3" O.D. x 1" thick.
- Includes instructions to locate grommet position for desks, credenzas, returns, and bridges.

! Black Finish

SPECIFYING EXAMPLE: HFLDGRMT3

OPEN MARKET

Field Installable Grommet — For 3" Diameter Hole**HFLDGRMT4**

0.1

0.01

\$32

- Intended for use in tops to route/hide cords.
- Requires a 3" diameter hole saw and drill for installation (not included).
- Includes grommet cap, with two access holes, and sleeve components.
- Outside dimension measures 3½" diameter.
- Sleeve hole in worksurface measures 3" O.D. x 1" thick.
- Includes instructions to locate grommet position for desks, credenzas, returns, and bridges.

! Platinum Finish

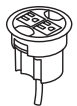
SPECIFYING EXAMPLE: HFLDGRMT4

SIN 33721T

Power Hub, 3" Grommet Mount, 6' Cord**HGRMTAC**

1.3

0.2

\$111

- Fits in 3" round grommet holes on the following product lines: 10500, 10700, Concinnity, Coordinate, and Voi desks; Abound Worksurfaces; Huddle and Motivate tables and SmartLink.
- Two grounded AC power outlets.
- Two cord pass-through holes in cap.
- Includes 6' cord with three-prong plug.
- Field installed; easy plug-and-play.
- UL Listed.

! Available in black only (no color designation so use .X - Specify: HGRMTAC.X).

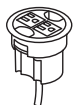

SIN 33721T

3" Round Power Grommet – 2 Outlets, 10' Cord**HGRMTAC2**

1.5

0.2

\$148

- Includes 10' cord with three-prong plug.
- Fits in 3" round grommet holes on the following product lines: Coordinate, Huddle, Motivate, all laminate and veneer casegoods series, and Systems Worksurfaces.
- Two grounded AC power outlets.
- Field installed with Plug-and-play ease.

NOTES: Power Modules will also work with standing-height applications for 10500 Series™ and Voi® desks. Optional Memory Control allows preset worksurface heights for consistency. Ships separately. Dynamic load capacity when worksurface is moving is 300 lbs.

! Available in black finish only, no specification needed.



SIN 33721T

Power/USB Hub, 3" Grommet Mount**HGRMTUSB2**

1.3 Ⓢ

0.2

\$224

- One grounded AC power outlet with 2 USB ports.
- Two cord pass-through holes in cap.
- Includes 6' cord with three-prong plug.
- Field installed; easy plug-and-play.
- UL Listed.





! Available in black only (no color designation so use .X - Specify: HGRMTUSB2.X).

HOW TO SPECIFYSelect
Model Number

HGRMTAC

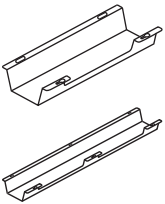

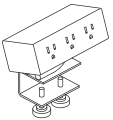
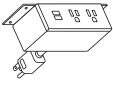
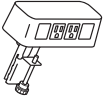
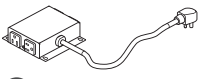
Icon Legend on page 19

	DESCRIPTION	MODEL	SHIP WEIGHT	CUBE	LIST PRICE
	Cable Management Troughs				
	17"W — Single	HCTROUGH17	2.7 Ⓢ	0.5	\$67
	17"W — 10-Pack	HCTROUGH1710	14.0 Ⓢ	0.5	\$620
	36"W — Single	HCTROUGH36	4.9 Ⓢ	0.9	\$113
	36"W — 10-Pack	HCTROUGH3610	30.0 Ⓢ	0.9	\$1045
	<ul style="list-style-type: none"> • Cable management troughs ship flat packed. • The troughs attach to underneath the worksurface with screws. • The 17"W has one wire access cut out on the user side. The 36" has two wire access cut outs. These cut outs give users access to inside the trough without having to detach it from the worksurface. • Color: Graphite. • Material: Metal. • TAA Compliant. 				
 <p>OPEN MARKET</p>	O-Leg Cord Clips				
	Clips for 28½" Worksurface O-Legs — 8-Pack	HWMCLIPLG	0.8 Ⓢ	0.1	\$99
	Clips for Layering O-Legs — 4-Pack	HWMCLIPSM	0.5 Ⓢ	0.1	\$65
	<p>NOTES: Wire clips work with 7" Low Credenza O-leg and 29"H Support O-leg.</p> <p>ⓘ Available in frosted plastic material only.</p>				
 <p>Model HPWRMOD3WC shown</p>  <p>Model HPWRMOD2UWM shown</p>	Power Modules				
	3 Receptacles with Worksurface Clamp	HPWRMOD3WC	2.3 Ⓢ	0.2	\$307
	3 Receptacles with Under-Worksurface Mounting Bracket	HPWRMOD3UWM	2.3 Ⓢ	0.2	\$307
	2 Receptacles 2 USB with Worksurface Clamp	HPWRMOD2WC	2.3 Ⓢ	0.2	\$491
	2 Receptacles 2 USB with Under-Worksurface Mounting Bracket	HPWRMOD2UWM	2.3 Ⓢ	0.2	\$491
	<ul style="list-style-type: none"> • 6' power cord with standard three-prong plug. • Under-worksurface mounting bracket models work with any top that has a 5" x 5" square clearance. • Worksurface clamp models work on any top with a 4" overhang. • UL Listed. <p>ⓘ Color finish coordinates with HON's Charcoal or White. Specify <i>STRM</i> for Storm or <i>SNW</i> for Snow when ordering. Example: <i>HPWRMOD3WC.STRM</i>.</p>				
	Power & Data Center				
	2 Receptacles 2 Data Accessory	HCOMDOME2	2.5 Ⓢ	0.2	\$293
	<ul style="list-style-type: none"> • Standard with two receptacles and openings for two data ports. • 6' power cord with standard three-prong plug. • Fits on any worksurface with a 4" overhang. • UL Listed. <p>ⓘ Color finish coordinates with HON's Loft. Specify <i>LOFT</i> when ordering. Example: <i>HCOMDOME2.LOFT</i>.</p>				
 <p>EZ</p>	Under Worksurface Power Module — 4 Outlets, 10' Cord				
		HPWRMOD2	1.5	0.2	\$401
	<ul style="list-style-type: none"> • Includes 10' cord with three-prong plug. • Fits in cable management troughs. • 4 outlets on side create easy access. <p>NOTES: Power Modules will also work with standing-height applications for 10500 Series™ and Voi® desks.</p> <p>ⓘ Available in black finish only, no specification needed.</p>				
	Vertebrae				
		HMPVWM28	3.0	0.3	\$221
	<p>NOTES: 30"H x 3¼"W x 1½"D. Ships unassembled.</p> <p>ⓘ Clear finish. Specify "X" for finish option.</p> <p>SPECIFYING EXAMPLE: HMPVWM28.X</p>				

HOW TO SPECIFY

Select Model Number

H P W R M O D 3 W C

CONCINNITY™

Accessories — Paper Organizers

GSA SIN 33721



Icon Legend on page 19

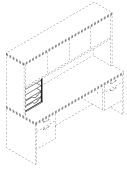

Not available in two-tone laminates

DESCRIPTION**Vertical Paper Manager**14⁷/₈"W x 10⁷/₈"D x 19¹/₈"H**MODEL****HLVPM1****SHIP WEIGHT**

27.0

CUBE

2.8

L1 LIST PRICE**\$327****L2 UPCHARGE****\$10**

NOTES: Keeps papers, files, and books neatly organized and within easy reach from a seated position. Designed for desk, credenza, and return tops. Fits under stack-on storage models. Two pullout drawers and three fixed shelves. Not available in pattern laminate colors. Ships fully assembled.

ⓘ When used in conjunction with wall mounted storage cabinets, allow 19³/₄" minimum clearance above the worksurface.

SPECIFYING EXAMPLE: HLVPM1.N

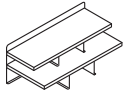

Not available in two-tone laminate

Desktop Storage Terrace26¹/₂"W x 12¹/₂"D x 10¹/₂"H**HLDSTI**

24.0

1.1

\$306**\$10**

NOTES: Keeps work-in-process, priority files, loose pages, and mail neatly organized and in view. Mixed material design comprised of sturdy laminate shelves with metal back and support panels. Not available in two-tone laminate combination or pattern laminate colors. Choose from Platinum Metallic (TI), Black (P), and Charcoal (S) for the metal components. Designed to be used on worksurfaces. Also sized to fit in stack-on and wall mounted storage cabinets, see compatibility chart on page 111.

Specify: Model.Laminate.Paint

SPECIFYING EXAMPLE: HLDSTI.N.TI

DESCRIPTION**Stacked Paper Management**32¹/₂"W x 12⁵/₈"D x 4¹/₄"H**MODEL****HLVPM2****SHIP WEIGHT**

22.0

CUBE

1.25

LIST PRICE**\$163**

NOTES: Segments and organizes stack-on and wall mount storage compartments (see compatibility chart on page 111), as well as bookcase shelves. In some cases, installation may require removing the stack-on or wall mount storage doors.

ⓘ Black only.

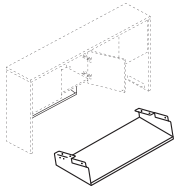
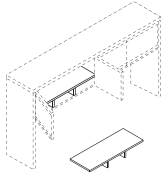
**Hanging Paper Shelf**28¹/₈"W x 11¹/₈"D x 4⁵/₈"H**HHPS1**

7.0

2.9

\$198

NOTES: Attaches quickly and easily (screws included). Maximizes worksurface space; de-clutters desktop while placing priority communications and active project folders within easy reach. Angled design allows contents to be distinguished at a glance. Mixed material styling features strong painted metal frame with a frosted shelf.

Attaches quickly and easily to laminate stack-on and wall mount storage models (except the 36"W Voi® overhead hutch with O-legs or panel mount brackets). Not for use with 38000 Series™ and Systems.

Specify: Model.Paint

SPECIFYING EXAMPLE: HHPS1.TI

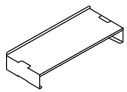
**Desktop Paper Shelf**28¹/₈"W x 11⁵/₈"D x 5"H**HDPS1**

7.0

2.9

\$198

NOTES: Desktop Paper Shelf and Storage Terrace include protective, non-slip pads on the base. Paper Shelf can stack two-high. Organizer shelf provides a place and space for work-in-process and piling to keep worksurfaces neat and tidy. Convenient, scalable design with interlocking side supports allow two units to be stacked and integrated. Durable painted metal frame with a frosted shelf; mixed material styling matches hanging paper shelf.

Can also be used inside select overhead storage, including the following stack-on with clearance and hinged door models: 10500 and Valido 36", 42", 66", 72", 78"W and 10700 68⁵/₈"W.

Specify: Model.Paint

SPECIFYING EXAMPLE: HDPS1.TI

**Storage Cube**

12"W x 12"D

HLSL1212

1.0

0.3

\$294

SPECIFYING EXAMPLE: HLSL1212.P8S

**HOW TO SPECIFY**

Select
Model Number

H L V P M 1 .

Select
Laminate Color

See page 29

N

CONCINNITY™ PAPER ORGANIZER COMPATIBILITY

PAPER ORGANIZERS FOR STACK-ON AND WALL MOUNTED STORAGE CABINETS

- Laminate vertical paper manager (HLVPM1) is designed for desk, credenza, and return tops; fits under stack-on and wall mount storage units.
- Laminate desktop storage terrace (HLDST1) for use on worksurfaces, or inside overhead storage compartments >26½"W.
- Metal desktop paper shelf (HDPS1) for use on worksurfaces, can be stacked two high, or inside overhead storage compartments >28¾"W.
- Stacked paper management (HLVPM2) can be positioned inside overhead storage cabinets >32½"W.
- Metal hanging paper shelf (HHPS1) attaches quickly and easily to the underside of stack-on and wall mounted storage models.
- For applications using the organizers inside stack-on and wall mounted storage compartments, the fit compatibility is as follows:

OUTSIDE WIDTH	INSIDE WIDTH	Stacked Paper Mgt. — 32½"W HLVPM2	Desktop Paper Shelf — 28¾"W HDPS1	Desktop Storage Terrace — 26½"W HLDST1	Hanging Paper Shelf — 28¾"W HHPS1
		Yes or No	Yes or No	Yes or No	*Qty — see NOTE
STACK-ON STORAGE W/ LAM DOORS, LAM LOCKING DOORS, FROSTED DOORS					
36"W	34.34	Y	Y	Y	1
42"W	40.34	Y	Y	Y	1
48"W (large compartment)	30.60	N	Y	Y	1
60"W	28.60	N	N	Y	2
66"W	31.60	N	Y	Y	2
72"W	34.60	Y	Y	Y	2
78"W	37.60	Y	Y	Y	2
STACK-ON STORAGE W/ SLIDING DOOR					
48"W	22.60	N	N	N	1
60"W	28.60	N	N	Y	2
66"W	31.60	N	Y	Y	2
72"W	34.60	Y	Y	Y	2
78"W	37.60	Y	Y	Y	2
WALL MOUNT STORAGE W/ LAM DOORS, LAM LOCKING DOORS, FROSTED DOORS					
30"W	28.35	N	N	Y	N
36"W	33.67	Y	Y	Y	1
42"W	39.67	Y	Y	Y	1
48"W (large compartment)	30.22	N	Y	Y	1
60"W	28.22	N	N	Y	2
66"W	31.22	N	Y	Y	2
72"W	34.22	Y	Y	Y	2
78"W	37.22	Y	Y	Y	2
WALL MOUNT STORAGE W/ SLIDING DOOR					
48"W	22.46	N	N	N	1
60"W	28.46	N	N	Y	2
66"W	31.46	N	Y	Y	2
72"W	34.46	Y	Y	Y	2
78"W	37.46	Y	Y	Y	2

*NOTE: For model HHPS1, quantity represents the number that can be mounted side-by-side under the cabinet.



CONCINNITY™

Accessories — Lock Kits

GSA SIN 33721 EXCEPT AS NOTED

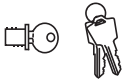
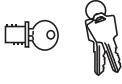

Icon Legend on page 19

	DESCRIPTION	MODEL	SHIP WEIGHT	CUBE	LIST PRICE
	Black Removable Lock Core Kit <ul style="list-style-type: none"> Specify quantity of each key number from 101E-225E. Includes: 1-core, 2-keys, 1-core removal tool, and instructions. NOTES: If key number isn't specified, number will be at random.	HF23B	0.1 Ⓞ	0.1	\$32
	Satin Removable Lock Core Kit <ul style="list-style-type: none"> Specify quantity of each key number from 101E-225E. Includes: 1-core, 2-keys, 1-core removal tool, and instructions. NOTES: If key number isn't specified, number will be at random.	HF23S	0.1 Ⓞ	0.1	\$40
	Removable Lock Core Kit Black Satin	HF27B HF27S	0.2 0.2	0.02 0.02	\$32 \$32
OPEN MARKET	<ul style="list-style-type: none"> For stack-on and wall mounted storage laminate models (with locks) in 10500, 10700, Valido, Voi, Concinnity, and 94000 Series. Specify quantity of each key number from 101E to 225E. Includes: 1-core, 2-keys, 1-core removal tool, and instructions. NOTES: If key number isn't specified, number will be at random.				

NOTES:

- Interchangeable core removable locks are standard on most HON products.
- Removable lock core kits with specific key number must be ordered to facilitate keying alike in the field.
- For keyed alike locks:
 - Order standard product which will be shipped with factory installed locks and random numbered cores.
 - Order the appropriate quantity of like numbered cores required for each workstation or keyed area.
 - Simply replace the factory installed cores with the replacement cores after product has been installed.
- To install new core:
 - Lock must be in the unlocked position.
 - Insert core removal key and pull core straight out.
 - Insert new core with core removable key, hold core into lock and withdraw core removal key.
 - Retain original core for future use.
- For master key, see model HF22 on page 853.
- To provide normal lead times, key numbers cannot be specified on HON products at time of order. This also eliminates need for tagging and tracking each product's lock number during installation.

HOW TO ORDER CORE REMOVABLE LOCK KITS:

Specify: Model Number.X
Key Number

Examples: HF23S.X121E
HF23S.X (Key number not specified)

NOTES: Key orders without numbers specified will be keyed at random.
Numbers 101E-225E are available.

SAMPLE ORDER:

Quantity	Model	Key Code
4	HF23B.	X121E

HOW TO SPECIFY

Select
Model Number

H F 2 3 B



CONCINNITY™

Accessories — Task Lights

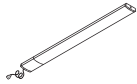

OPEN MARKET

DESCRIPTION**MODEL****SHIP WEIGHT****CUBE****LIST PRICE****LED Task Lights — For Stack-on and Wall Mounted Storage Cabinets**

17" LED Light with Power Supply (Single)

HLED17AS

1.2 Ⓢ

0.05

\$420

31" LED Light with Power Supply (Single)

HLED31AS

1.5 Ⓢ

0.09

\$565

17" LED Light with Power Supply for Daisy-chain (Starter)

HLED17A

1.0 Ⓢ

0.05

\$462

31" LED Light with Power Supply for Daisy-chain (Starter)

HLED31A

1.4 Ⓢ

0.09

\$620

17" LED Light with 8" Jumper Cord for Daisy-chain (Follower)

HLED17AUO

1.0 Ⓢ

0.03

\$377

31" LED Light with 8" Jumper Cord for Daisy-chain (Follower)

HLED31AUO

1.0 Ⓢ

0.05

\$502**Undercabinet Occupancy Sensor with 1" End to End Connector****HLEDOSA**

0.2 Ⓢ

0.01

\$89

NOTES: To use the daisy chain application, must start with model HLED17A or HLED31A. No finish specification required. Attaches magnetically to underside of overhead storage, or attaches with provided screws or double-sided tape. Occupancy sensor attaches to a single or starter LED light and will automatically turn the light off after no motion is detected for 30 minutes. Just like all the LED light models, the occupancy sensor features a soft-touch on/off switch. LED task lights have a lifetime of 50,000 hours and have a dimmer feature that allows the user to adjust the amount of light output.

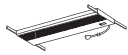

OPEN MARKET

Recessed Task Lights — For Stack-on and Wall Mounted Storage Cabinets

- Color: Black.
- Slim profile design.
- Mount to stack-on storage and wall mounted storage cabinets (see pages 55-59 and 62-65).
- Electronic ballast for increased energy efficiency.
- T5 bulb, included, which contains less mercury.
- 9-foot black cord and switch off right rear corner.

22⁷/₈"W x 3¹/₁₆"D x 1¹/₈"H

Chicago code version (with fused plug)

HH870930

7.0 Ⓢ

0.60

\$23134⁵/₈"W x 3¹/₁₆"D x 1¹/₈"H

Chicago code version (with fused plug)

HH870930CH

7.0 Ⓢ

0.60

\$30146¹/₂"W x 3¹/₁₆"D x 1¹/₈"H

Chicago code version (with fused plug)

HH870942

10.0 Ⓢ

0.90

\$25046¹/₂"W x 3¹/₁₆"D x 1¹/₈"H

Chicago code version (with fused plug)

HH870942CH

10.0 Ⓢ

0.90

\$31746¹/₂"W x 3¹/₁₆"D x 1¹/₈"H

Chicago code version (with fused plug)

HH870960

12.0 Ⓢ

1.10

\$27046¹/₂"W x 3¹/₁₆"D x 1¹/₈"H

Chicago code version (with fused plug)

HH870960CH

12.0 Ⓢ

1.10

\$337

SIN 33721

Articulating Desk Lamp**HLED1**

1.2 Ⓢ

6.5

\$402**Articulating Desk Lamp w/ Occupancy Sensor****HLED10C**

1.2 Ⓢ

6.5

\$490

SIN 33721

Task Desk Lamp**HLED2**

0.7 Ⓢ

3.0

\$348**HOW TO SPECIFY**Select
Model Number

H H 8 7 0 9 3 0



Refer to pages 829-830 for additional product information

SIN 33721



DESCRIPTION	MODEL	SHIP WEIGHT	CUBE	LIST PRICE BY PAINT GRADE	
				P1	P2
Sit to Stand Arm with Convertible Keyboard Platform	H2516 OPEN MARKET *	17 ₤	1.6	\$618	
Articulating Arm with Convertible Keyboard Platform	H2107 OPEN MARKET *	16 ₤	1.3	\$529	
Articulating Arm with Keyboard Platform	H1706 OPEN MARKET *	16 ₤	1.4	\$493	
Slide-Away Keyboard Platform (Specify: Laminate)	H4022	10 ₤	0.6	\$213	
Extended Tray Slide-Away Keyboard Platform (Specify: Laminate)	HE4022	12 ₤	0.7	\$302	
Metal Keyboard and Mouse Tray (Specify paint)	H4028 OPEN MARKET	11 ₤	1.5	\$153	\$163
Metal Keyboard Tray (Specify paint)	H4029 OPEN MARKET	11 ₤	1.5	\$138	\$148

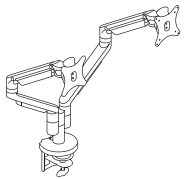

DESCRIPTION	MODEL	SHIP WEIGHT	CUBE	LIST PRICE
Dual Dynamic Monitor Arm <ul style="list-style-type: none"> • 150° of rotation at base with optional 360° rotation. • Arms extend 22" and retract up to 3". • Monitor mount rotates 180° and tilts +/-30°. • Monitor can be rotated from landscape to portrait position. <p>! Arms hold monitors from 6.2-18 lbs. Optional counterweight HPACW available to support monitors as low as 5 lbs. (see page 827).</p>	HMASD	17.0 ₤	1.1	\$750

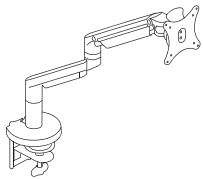

Single Dynamic Monitor Arm <ul style="list-style-type: none"> • 180° of rotation at base with optional 360° rotation. • Arms extend 22" and retract up to 3". • Monitor mount rotates 180° and tilts +/-30°. • Monitor can be rotated from landscape to portrait position. <p>! Arms hold monitors from 6.2-18 lbs. Optional counterweight HPACW available to support monitors as low as 5 lbs. (see page 827).</p>	HMASTS	11.5 ₤	0.8	\$390
--	--------	--------	-----	-------

NOTES:

Monitor Arms Only

- Arms fold back to post to allow more desktop room.
- Arms feature double extension, allowing 20"+ of back and forth movement.
- Cable management on both pole and arm assemblies.
- Counterbalance adjustment provides stability for monitors up to 17 lbs per arm.
- Made of high quality aluminum alloy material.
- See pages 825-826 for additional monitor arm models.

* De-emphasized.

HOW TO SPECIFY

Select Model Number

H M A S D .

Select Finish

Specify for models HMASD and HMASTS only

SVR Silver
BLK Black

S V R

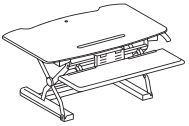
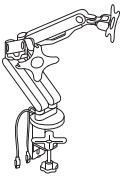
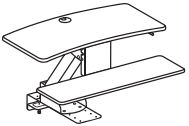
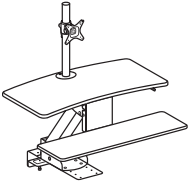
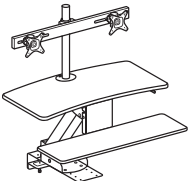

	DESCRIPTION	MODEL	SHIP WEIGHT	CUBE	LIST PRICE
	<p>Coordinate™ Portable Desktop Riser 31"D x 5"-16½"H x 35"W</p> <p>NOTES: Available in Black (BLK) or White (WHT) finish. Desktop riser dimensions (without keyboard tray): 22"D x 5"-16½"H x 35"W. Keyboard tray dimensions: 9"D x 30"W. Max loading capacity is 33 lbs for the desktop riser surface and 4 lbs for the keyboard tray. Easily transition from seated to standing positions throughout the workday. Sits atop an existing desk to create sit-to-stand functionality by raising the computer. Includes keyboard tray and surface for computer monitors. HON 5-Year Limited Warranty.</p> <p>ⓘ Not intended for use on mobile workstations.</p>	HBXRISER	54.0	4.1	\$619
	<p>Dual Monitor Arm with 2 USB Ports</p> <p>NOTES: Easy adjustment. Height adjusts to 17" tall. Monitor tilt and swivel capability. Enclosed cable management. Grommet or desktop mounting. Clean appearance. In some applications the Monitor Arms may extend 12 or more inches into the worksurface. HON 5-Year Limited Warranty.</p> <p>ⓘ No specification needed.</p>	HBDMAUSB	41.9	2.6	\$441
	<p>Coordinate™ Mounted Desktop Riser</p> <p>NOTES: Does not include a monitor arm and is suitable for laptops and/or monitors on their original stands.</p> <p>ⓘ No specification needed.</p>	HS1100	60.0 Ⓞ	3.2	\$664
	<p>Coordinate™ Mounted Desktop Riser with Single Monitor Arm</p> <p>NOTES: Includes a monitor arm for a single monitor.</p> <p>ⓘ No specification needed.</p>	HS1101	62.0 Ⓞ	3.2	\$777
	<p>Coordinate™ Mounted Desktop Riser with Dual Monitor Arm</p> <p>NOTES: Includes a monitor arm for dual monitors.</p> <p>ⓘ No specification needed.</p>	HS1102	63.0 Ⓞ	3.2	\$883

NOTES FOR HS1100, HS1101, HS1102:

- These products are designed to allow the user to transition from seating position to standing position throughout the workday.
- Gas-assist lever-operated mechanism with positive stop.
- Clamp mount compatible with worksurfaces depths of 20"-30". 20" is for systems only.
- Clamp requires 3.5" of clearance along back edge of worksurface.
- Black seamless worksurfaces.
- Silver powder coated metal components.
- Lowers below worksurface level on 24" and 30"D worksurfaces.
- All models contain a large primary worksurface and a smaller keyboard / mouse surface.
- Beveled edges for sleek appearance and comfort while typing.
- Monitor arms include height, width, and swivel adjustment.

- Not for use under overhead storage, with flush mounted modesty panels, or worksurfaces thinner than 1".

ⓘ Not recommended for use on mobile (castered) worksurfaces.

MOUNTING AND COMPATIBILITY FOR HS1100, HS1101, HS1102:

- This product is intended to be installed on commercial-grade worksurfaces in good condition.
- Compatible with freestanding worksurfaces 24"-30"D or panel-supported worksurfaces 24"-30"D.
- Not for use on mobile worksurfaces.

Clamp Mount

Use when 3.5" minimum overhang is available

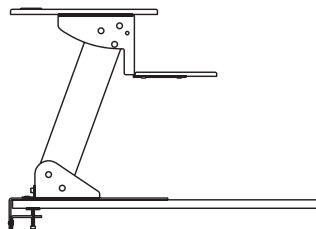

Screw Mount

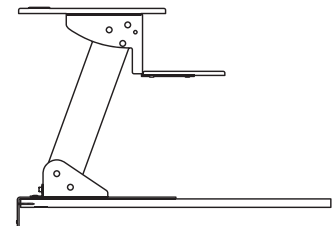

Use when no overhang is available. Worksurface must be minimum 1" thick.



HOW TO SPECIFY

<p>Select Model Number</p> <p>HBXRISER.</p>	<p>Select Finish</p> <p>BLK Black WHT White</p> <p>BLK</p>
--	---

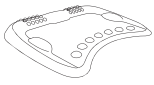
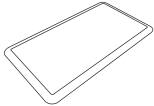
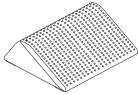

	DESCRIPTION	MODEL	SHIP WEIGHT	CUBE	LIST PRICE
	Rectangle Wobble Board — Anti-Fatigue Mat 18"D x 3"H x 22½"W ⓘ Available in Black (T) finish ONLY. Recommended weight capacity not to exceed 250 pounds. HON 5-Year Limited Warranty. SPECIFYING EXAMPLE: HVL981.T	HVL981	10.0 ⓘ	0.9	\$120
	Round Wobble Board — Anti-Fatigue Mat 18½"D x 2½"H x 18½"W ⓘ Available in Black (T) finish ONLY. Recommended weight capacity not to exceed 250 pounds. HON 5-Year Limited Warranty. SPECIFYING EXAMPLE: HVL982.T	HVL982	5.8 ⓘ	0.6	\$102
	Ergonomic Anti-Fatigue Mat 25"D x 2¾"H x 29⅞"W ⓘ Available in Black ONLY. No specification needed. SPECIFYING EXAMPLE: HBEAFM1	HBEAFM1	7.0	1.4	\$219
	Rectangle Anti-Fatigue Mat 20"D x ¾"H x 36"W ⓘ Available in Black ONLY. No specification needed. SPECIFYING EXAMPLE: HBAFM2036	HBAFM2036	5.4	0.4	\$100
	Footrest — Anti-Slip Cover 13¾"D x 5½"H x 16"W ⓘ Available in Black (T) finish ONLY. Recommended weight capacity not to exceed 250 pounds. HON 5-Year Limited Warranty. SPECIFYING EXAMPLE: HVL991.T	HVL991	7.0 ⓘ	0.9	\$82

HOW TO SPECIFY

Select
Model Number

H V L 9 8 1 .

Select
Finish

T Black

T



Foundation™ Executive Workstation.

FOUNDATION™

Create a solid starting point for your success with HON Foundation. Personalize your office suite with this versatile collection of laminate desk and storage solutions that can be combined in a variety of ways to fit any work style or space. Get the fundamentals and much more with the HON Foundation laminate collection.



FEATURES

- The HON Foundation collection allows you to create a premium workspace at an affordable price.
- Straightforward styling blends with any office design.
- Lateral files and storage pedestals come fully assembled, and desks and credenzas assemble easily in minutes.
- Multiple storage options let you create spaces that work the way you do.
- All components feature attractive scratch- and stain-resistant laminate for an unbeatable combination of stunning beauty and rugged durability.
- Available in three beautiful woodgrain finishes.
- Three optional decorative handles to choose from.

FOUNDATION™

Typicals

QTY	DESCRIPTION	MODEL	LIST PRICE	PRICE EXTENSION
1	Desk Shell	HLM6630	\$287	\$287
1	Box / Box / File Pedestal	HLMBBF	\$334	\$334
1	File / File Pedestal	HLMFF	\$334	\$334
TOTAL:			\$955	

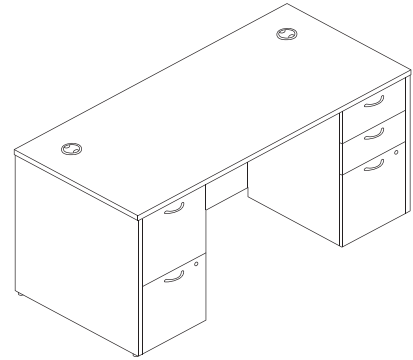

LAMINATE DESK WITH 2 PEDESTALS

66" W x 30" D

QTY	DESCRIPTION	MODEL	LIST PRICE	PRICE EXTENSION
1	Desk Shell	HLM6030	\$263	\$263
1	File / File Pedestal	HLMFF	\$334	\$334
TOTAL:			\$597	

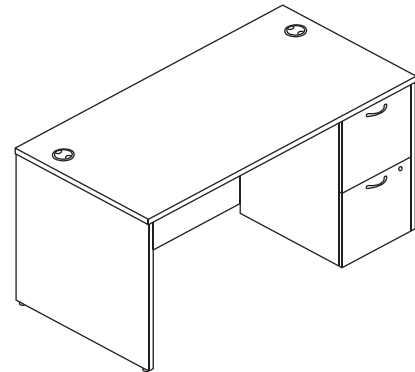

DESK SHELL WITH 1 PEDESTAL (NON-HANDED)

60" W x 30" D

QTY	DESCRIPTION	MODEL	LIST PRICE	PRICE EXTENSION
1	Desk Shell	HLM7236	\$334	\$334
1	Credenza Shell	HLM72CRD	\$270	\$270
1	Hutch with Doors	HLM72HUT	\$464	\$464
2	Box / Box / File Pedestal	HLMBBF	\$334	\$668
2	File / File Pedestal	HLMFF	\$334	\$668
TOTAL:			\$2,404	

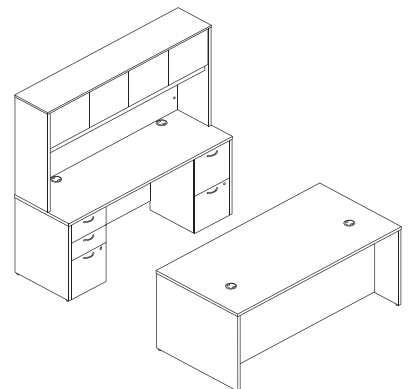

OFFICE SUITE

72" W x 96" D

QTY	DESCRIPTION	MODEL	LIST PRICE	PRICE EXTENSION
1	Desk Shell	HLM6630	\$287	\$287
1	Return Shell	HLM48RET	\$208	\$208
1	Box / Box / File Pedestal	HLMBBF	\$334	\$334
1	File / File Pedestal	HLMFF	\$334	\$334
TOTAL:			\$1,163	

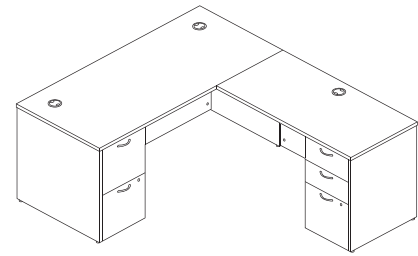

L-STATION WITH 2 PEDESTALS (NON-HANDED)
66"W x 78"D

QTY	DESCRIPTION	MODEL	LIST PRICE	PRICE EXTENSION
1	Bow Front Desk Shell	HLM7242	\$384	\$384
1	Credenza Shell	HLM72CRD	\$270	\$270
1	Hutch with Doors	HLM72HUT	\$464	\$464
1	5-Shelf Bookcase	HLM65BC	\$304	\$304
1	2-Drawer Lateral File	HMLLATF	\$542	\$542
2	Box / Box / File Pedestal	HLMBBF	\$334	\$668
2	File / File Pedestal	HLMFF	\$334	\$668
TOTAL:			\$3,300	

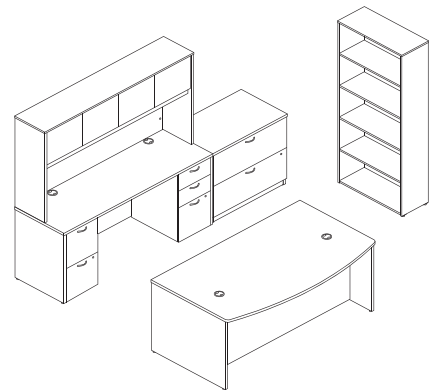

OFFICE SUITE WITH STORAGE
108"W x 134"D

QTY	DESCRIPTION	MODEL	LIST PRICE	PRICE EXTENSION
1	Desk Shell	HLM7236	\$334	\$334
1	Credenza Shell	HLM72CRD	\$270	\$270
1	Bridge	HLM48BRG	\$197	\$197
1	Box / Box / File Pedestal	HLMBBF	\$334	\$334
1	File / File Pedestal	HLMFF	\$334	\$334
TOTAL:			\$1,469	

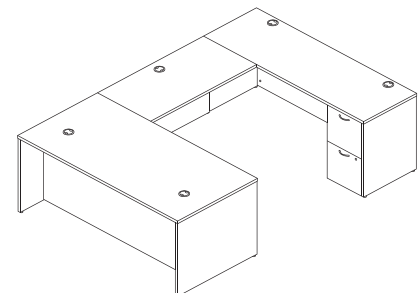

U-STATION (NON-HANDED)
72"W x 108"D

FOUNDATION™

Icon Legend on page 19

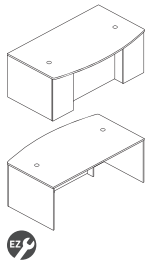

DESCRIPTION

Breakfront Desk Shell with Bow Front Top
72"W x 42"D x 29"H

NOTES: Two cord management grommets in tops.

OVERHANG

12⁹/₁₀"

MODEL

HLM7242BF

SHIP WEIGHT

156.2

CUBE

9.6

LIST PRICE

\$478

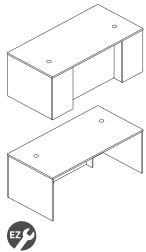

Breakfront Desk Shell with Rectangle Top
72"W x 42"D x 29"H

NOTES: Two cord management grommets in tops.

6⁷/₁₀"

HLM7236BF

151.8

8.4

\$426

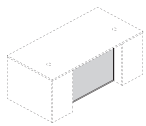

Glass Modesty Panel
For 72"W Breakfront Desk Shell

NOTES: Glass modesty replaces laminate modesty included with desk.

HBL72BFMODG

18.0

2.0

\$257

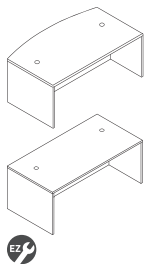

Desk Shell
72"W x 42"D x 29"H, Bow Top
72"W x 36"D x 29"H, Rectangle Top
66"W x 30"D x 29"H, Rectangle Top
60"W x 30"D x 29"H, Rectangle Top

NOTES: Two cord management grommets in tops.

16¹/₂"

HLM7242

153.9

8.9

\$384

10"

HLM7236

148.8

7.7

\$334

4¹/₂"

HLM6630

115.7

6.1

\$287

4¹/₂"

HLM6030

111.1

5.6

\$263



Peninsula with End Panel
72"W x 36"D x 29"H

NOTES: Support column available in Black only. For use in "U" or "L" configuration.

Not designed to be used freestanding.

HLM72PEN

116.4

15.0

\$432



NOTES:

- Scratch- and stain-resistant thermal-fused laminate surfaces.
- Durable 1" thick tops and end panels.
- Full height modesty panels.
- Desk, credenza shells, and peninsula assemble quickly and easily.
- Breakfront design creates a high end aesthetic for private offices and executive workstations.

- Desk shells come standard with 3" round Black grommets.
- Recessed modesty panel design on desk shells provides overhang for visitor meetings and conferencing.
- Glass modesty replaces laminate modesty included with desk.
- Adjustable floor leveling glides provide 3/4" of adjustment.
- **HON 5-Year Limited Warranty.**

HOW TO SPECIFY

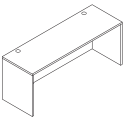
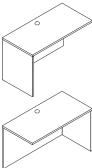
<p>Select Model Number</p> <p>H L M 7 2 4 2 B F</p>	<p>Select Laminate</p> <p>F Shaker Cherry N Mahogany PINC Pinnacle</p> <p>F</p>
--	--

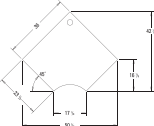
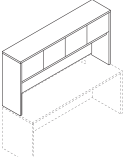
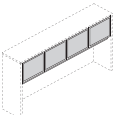
	DESCRIPTION	MODEL	SHIP WEIGHT	CUBE	LIST PRICE
	Credenza Shell 72"W x 24"D x 29"H 60"W x 24"D x 29"H NOTES: Two cord management grommets in the top and one cord pass-through grommet in the top center of modesty panel.	HLM72CRD	108.0	5.5	\$270
		HLM60CRD	95.5	5.5	\$240
	Return Shell 48 1/4"W x 24"D x 29"H 42 1/4"W x 24"D x 29"H NOTES: One cord management grommet in the top and one cord pass-through grommet in the top center of modesty panel. Return shells are non-handed.	HLM48RET	66.1 Ⓔ	4.6	\$208
		HLM42RET	66.1 Ⓔ	4.1	\$192
	Bridge 47 3/4"W x 24"D x 29"H NOTES: One cord management grommet in the top and one cord pass-through grommet in the top center of modesty panel.	HLM48BRG	52.9 Ⓔ	3.7	\$197
	Corner Unit 18" x 36" x 36" x 18" x 29"H NOTES: Intended for use with 24"D x 29"H returns or bridges. ! Not designed to be used freestanding.	 HLM42CU	114.4	5.1	\$386
	Hutch with Doors 72"W x 14 5/8"D x 37 1/8"H 60"W x 14 5/8"D x 37 1/8"H NOTES: 72"W Hutch with four doors fits on the 72"W desk or credenza. It can also span an "L" configuration where the width of the return and the depth of the desk or credenza combined equal 72". Example: 42"W return and a 30"D desk shell. 60"W Hutch with doors fits on the 60"W desk or credenza shell.				
	Glass Doors for 72" Hutch NOTES: Glass doors replace laminate doors included with hutch.	HBL72HDG	9.0 Ⓔ	1.5	\$330



NOTES:

- Credenza shells, return shells, and bridges come standard with 3" round Black grommets.
- Scratch- and stain-resistant thermal-fused laminate surfaces.
- Durable 1" thick tops and end panels.
- Full height modesty panels.
- Adjustable floor leveling glides provide 3/4" of adjustment.
- 72"W and 60"W hutches with doors include fully enclosed back with a grommet to facilitate routing cords.
- Credenza shell, returns, bridges, corner units, and hutches assemble quickly and easily.
- Glass doors replace laminate doors included with hutch.
- **HON 5-Year Limited Warranty.**

HOW TO SPECIFY

<p>Select Model Number</p> <p>H L M 7 2 C R D .</p>	<p>Select Laminate</p> <p>F Shaker Cherry N Mahogany PINC Pinnacle</p> <p>F</p>
--	---

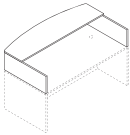
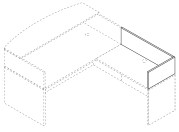

	DESCRIPTION	MODEL	SHIP WEIGHT	CUBE	LIST PRICE
	Reception Station with Bow Front Transaction Counter 72"W x 42"D x 14"H NOTES: Can be used on 72"W x 42"D bow top and 72"W x 36"D rectangle top desks. Can be used to quickly convert existing 72"W desks and 42¼"W returns into reception stations.	HLMRECP	74.1	5.4	\$322
	Reception Station for Returns 42¼"W x 24"D x 13"H NOTES: To be used with model HLMRECP in an "L" configuration on a 42¼" return shell. Can be used to quickly convert existing 72"W desks and 42¼"W returns into reception stations.	HLMRECPRET	23.1 	2.0	\$139
	Personal Wardrobe Cabinet 18"W x 24"D x 65"H NOTES: Door is non-handed and can be converted to left or right open configuration. Features coat rod, fixed shelf, and lock. Comes with metal handle in Silver finish.	HLMPPWC	83.6	6.1	\$547

NOTES:

- Scratch- and stain-resistant thermal-fused laminate surfaces.
- Durable 1" thick tops and end panels.
- Adjustable floor leveling glides provide ¾" of adjustment.
- Reception stations, returns, and wardrobe cabinet assemble quickly and easily.
- 3" round Black grommet(s) in tops of desks to route cords.
- **HON 5-Year Limited Warranty.**

HOW TO SPECIFY

Select Model Number H L M R E C P .	Select Laminate F Shaker Cherry N Mahogany PINC Pinnacle F
---	---

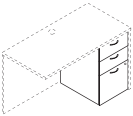
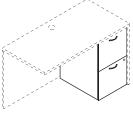
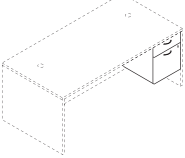
	DESCRIPTION	MODEL	SHIP WEIGHT	CUBE	LIST PRICE
	Pedestals, Box/Box/File 15 ⁵ / ₈ "W x 20 ¹ / ₂ "D x 27 ³ / ₄ "H NOTES: Drawers lock. Not to be used freestanding. For use under shells (sold separately). Unfinished top.	HLMBBF	62 Ⓢ	7.4	\$334
	Pedestal, File/File 15 ⁵ / ₈ "W x 20 ¹ / ₂ "D x 27 ³ / ₄ "H NOTES: Drawers lock. Not to be used freestanding. For use under shells (sold separately). Unfinished top.	HLMFF	61 Ⓢ	7.4	\$334
	Pedestal, Box/File 15 ⁵ / ₈ "W x 20 ¹ / ₂ "D x 20 ¹ / ₂ "H NOTES: Drawers lock. Not to be used freestanding. For use under shells (sold separately). Unfinished top.	HLMBF	54 Ⓢ	5.8	\$257

NOTES:

- Pedestals ship assembled.
- Pedestals are designed to be used under the desk, credenza, and return shells.
- Drawers operate on full extension, ball-bearing suspensions to ensure smooth, quiet, long-lasting operation.
- Pedestals come standard with Arch pull in Silver finish.
- **HON 5-Year Limited Warranty.**

HOW TO SPECIFY

<p>Select Model Number</p> <p>HLMBBF.F</p>	<p>Select Laminate</p> <p>F Shaker Cherry N Mahogany PINC Pinnacle</p> <p>F</p>
---	--

FOUNDATION™

Icon Legend on page 19

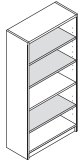

DESCRIPTION

Bookcases

32"W x 13¹³/₁₆"D x 65³/₈"H — 5-Shelf

NOTES: Features three adjustable shelves and one fixed shelf.

MODEL

HLM65BC

SHIP WEIGHT

137.3

CUBE

7.2

LIST PRICE

\$304

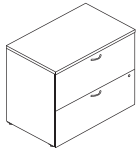

Lateral Files — 2-Drawer

35¹/₂"W x 20"D x 29"H

NOTES: Features inner lock mechanism. Drawers lock. Features full extension drawers with ball-bearing suspensions.

HLMLATF

174.0

15.8



\$542

NOTES:

- Lateral files ship assembled.
- Drawers operate on full extension, ball-bearing suspensions to ensure smooth, quiet, long-lasting operation.
- Hangrails are included in each file drawer for side-to-side letter or legal filing, and for front-to-back letter filing.
- Lateral files come standard with Arch pull in Silver finish.
- **HON 5-Year Limited Warranty.**

HOW TO SPECIFY

<p>Select Model Number</p>	<p>Select Laminate</p> <p>F Shaker Cherry N Mahogany PINC Pinnacle</p>
<p>H L M 6 5 B C .</p>	<p>F</p>

	DESCRIPTION	MODEL	SHIP WEIGHT	CUBE	LIST PRICE
	Field Installed Contemporary Pull — 2-pack Silver NOTES: For use on Lateral Files, Pedestals, and Personal Wardrobe Cabinets. ⓘ Silver finish only, no specification needed.	HBLPCONTEMP	0.4 ⓘ	0.1	\$12
	Field Installed Bridge Pull — 2-pack Silver NOTES: For use on Lateral Files, Pedestals, and Personal Wardrobe Cabinets. ⓘ Polished finish only, no specification needed.	HBLPBRIDGE	0.4 ⓘ	0.1	\$12
	Field Installed Classic Pull — 2-pack Black NOTES: For use on Lateral Files, Pedestals, and Personal Wardrobe Cabinets. ⓘ Black finish only, no specification needed.	HBLPCLASSIC	0.4 ⓘ	0.1	\$12

NOTES:
 • HON 5-Year Limited Warranty.

HOW TO SPECIFY

Select Model Number

H	L	M	P	C	O	N	T	E	M	P
---	---	---	---	---	---	---	---	---	---	---

FOUNDATION™ Conference Tables

OPEN MARKET



Icon Legend on page 19

	DESCRIPTION	MODEL	SHIP WEIGHT	CUBE	LIST PRICE
	Rectangular Conference Table with Slab Base 72"W x 36"D	HLMC72R	118	9.2	\$367
	Round Conference Table with "X" Base 47" Diameter	HLMC48D	110	7.9	\$302

NOTES:

- Tops and bases are packaged together.
- Durable, thermal-fused laminate is scratch- and spill-resistant.
- **HON 5-Year Limited Warranty.**

HOW TO SPECIFY

Select
Model Number

Select
Laminate

F Shaker Cherry
N Mahogany
PINC Pinnacle

H L M C 7 2 R .

F

Icon Legend on page 19

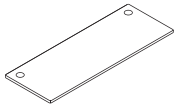

DESCRIPTION

Worksurfaces for Height Adjustable Bases

48"W x 24"D
60"W x 24"D
66"W x 24"D
72"W x 24"D

48"W x 30"D
60"W x 30"D
66"W x 30"D
72"W x 30"D

MODEL

SHIP WEIGHT

CUBE

LIST PRICE

HLMW4824	61	3.4	\$136
HLMW6024	75	4.2	\$159
HLMW6624	82	5.0	\$172
HLMW7224	89	5.0	\$179
HLMW4830	75	4.2	\$179
HLMW6030	92	5.1	\$224
HLMW6630	101	6.1	\$241
HLMW7230	110	6.1	\$260

NOTES:

- Select from Shaker Cherry, Mahogany or Pinnacle laminates to match Foundation™ desks.
- Compatible with Coordinate™ Height Adjustable Bases.
- 1" Thick worksurfaces.
- 3" round Black grommets included.
- **HON 5-Year Limited Warranty.**

HOW TO SPECIFY

Select
Model Number

H L M W 4 8 2 4 .

Select
Laminate

F Shaker Cherry
N Mahogany
PINC Pinnacle

F

FOUNDATION™ Height Adjustable Bases

OPEN MARKET



Icon Legend on page 19

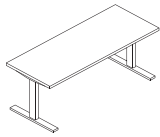

Base shown with work surface attached.

DESCRIPTION**MODEL****SHIP WEIGHT****CUBE****LIST PRICE****Coordinate™ Height Adjustable Base – 2 Stage**

24"D Feet and Worksurface Brackets

HHAB2S2L

63

2.4

\$1006

NOTES: Base is a dual motor 2-stage design with standard anti-collision. Legs raise from 25⁵/₈" to 45¹/₄". Base telescopes to accommodate any rectangular work surface between 24"D x 48"W and 30"D x 72"W. Supports weight capacity of 250 lbs. (excluding work surface weight). See page 718 for Voi® Worksurfaces. See page 718 for Systems Worksurfaces. For Height Adjustable Base Accessories see page 716. Foundation™, Systems, Voi®, 10500, and Preside® all have work surfaces within this range.

⚠ When attaching a Keyboard Tray, remember to also specify a Keyboard Spacer Kit (HKBS).

⚠ Telescoping horizontal frame will extend just over 2" from underside of the work surface.

SPECIFYING EXAMPLE: HHAB2S2L.P8L

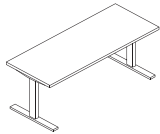

Base shown with work surface attached.

Coordinate™ Height Adjustable Base – 3 Stage

24"D Feet and Worksurface Brackets

HHAB3S2L

67

2.4

\$1120

NOTES: Base is a dual motor 3-stage design with standard anti-collision. Legs raise from 21⁵/₈" to 47³/₄". Base telescopes to accommodate any rectangular work surface between 24"D x 48"W and 30"D x 72"W. Supports weight capacity of 250 lbs. (excluding work surface weight). Foundation™, Systems, Voi®, 10500, and Preside® all have work surfaces within this range.

⚠ Telescoping horizontal frame will extend just over 2" from underside of the work surface.

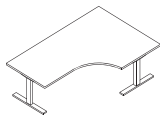

Base shown with work surface attached.

Coordinate™ 3-Leg Height Adjustable Base – 3 Stage

24"D Feet and Worksurface Brackets

HHAB3S3L

91

3.6

\$1896

NOTES: Base is a three motor 3-stage design with standard anti-collision. Legs raise from 21⁵/₈" to 47³/₄". **The 3-leg base supports corner covers or two-piece work surfaces 41"-72"W x 35"-72"L x 23¹/₄"-30"D. 48"W 120 degree corner work surfaces are also supported. When using two work surfaces, the connection between the two must be over the telescoping frame. Supports weight capacity of 375 lbs.** (excluding work surface weight). Can be used with 48" 120 degree and work surface models.

⚠ When using two work surfaces, a flat bracket is required. Bracket purchased separately — HHN831124, HHN831130 — see page 589.

⚠ Telescoping horizontal frame will extend just over 2" from underside of the work surface.

NOTES:

- Comes standard with one-touch, four memory controller with digital display; no specification needed, available in black finish only.
- **HON 5-Year Limited Warranty.**

⚠ 120 degree and corner work surfaces are not reduced in size to provide clearance between panels.

⚠ Coordinate™ Height Adjustable Bases not compatible with 36"D rectangular work surfaces.

HOW TO SPECIFY

Select Model Number H H A B 2 S 2 L .	Select Finish P71 Black P8L Nickel PD8 White
---	--

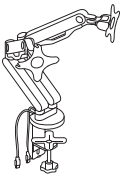
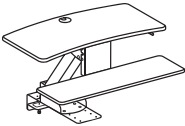
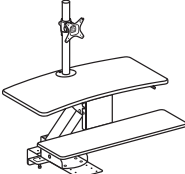
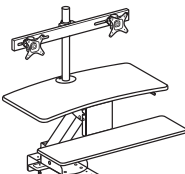
	DESCRIPTION	MODEL	SHIP WEIGHT	CUBE	LIST PRICE
	<p>Coordinate™ Portable Desktop Riser 31"D x 5'-16½"H x 35"W</p> <p>NOTES: Available in Black (BLK) or White (WHT) finish. Desktop riser dimensions (without keyboard tray): 22"D x 5'-16½"H x 35"W. Keyboard tray dimensions: 9"D x 30"W. Max loading capacity is 33 lbs for the desktop riser surface and 4 lbs for the keyboard tray. Easily transition from seated to standing positions throughout the workday. Sits atop an existing desk to create sit-to-stand functionality by raising the computer. Includes keyboard tray and surface for computer monitors. HON 5-Year Limited Warranty.</p> <p>ⓘ Not intended for use on mobile workstations.</p>	HBXRISER	54.0	4.1	\$619
	<p>Dual Monitor Arm with 2 USB Ports</p> <p>NOTES: Easy adjustment. Height adjusts to 17" tall. Monitor tilt and swivel capability. Enclosed cable management. Grommet or desktop mounting. Clean appearance. In some applications the Monitor Arms may extend 12 or more inches into the worksurface. For additional information see page 825. HON 5-Year Limited Warranty.</p> <p>ⓘ No specification needed.</p>	HBDMAUSB	41.9	2.6	\$441
	<p>Coordinate™ Mounted Desktop Riser</p> <p>NOTES: Does not include a monitor arm and is suitable for laptops and/or monitors on their original stands.</p> <p>ⓘ No specification needed.</p>	HS1100	60.0 ⓘ	3.2	\$664
	<p>Coordinate™ Mounted Desktop Riser with Single Monitor Arm</p> <p>NOTES: Includes a monitor arm for a single monitor.</p> <p>ⓘ No specification needed.</p>	HS1101	62.0 ⓘ	3.2	\$777
	<p>Coordinate™ Mounted Desktop Riser with Dual Monitor Arm</p> <p>NOTES: Includes a monitor arm for dual monitors.</p> <p>ⓘ No specification needed.</p>	HS1102	63.0 ⓘ	3.2	\$883

NOTES FOR HS1100, HS1101, HS1102:

- These products are designed to allow the user to transition from seating position to standing position throughout the workday.
- Gas-assist lever-operated mechanism with positive stop.
- Clamp mount compatible with worksurfaces depths of 20"-30". 20" is for systems only.
- Clamp requires 3.5" of clearance along back edge of worksurface.
- Black seamless worksurfaces.
- Silver powder coated metal components.
- Lowers below worksurface level on 24" and 30"D worksurfaces.
- All models contain a large primary worksurface and a smaller keyboard / mouse surface.
- Beveled edges for sleek appearance and comfort while typing.
- Monitor arms include height, width, and swivel adjustment.
- For additional information see page 838.

- Not for use under overhead storage, with flush mounted modesty panels, or worksurfaces thinner than 1".

ⓘ Not recommended for use on mobile (castered) worksurfaces.

MOUNTING AND COMPATIBILITY FOR HS1100, HS1101, HS1102:

- This product is intended to be installed on commercial-grade worksurfaces in good condition.
- Compatible with freestanding worksurfaces 24"-30"D or panel-supported worksurfaces 24"-30"D.
- Not for use on mobile worksurfaces.

Clamp Mount

Use when 3.5" minimum overhang is available

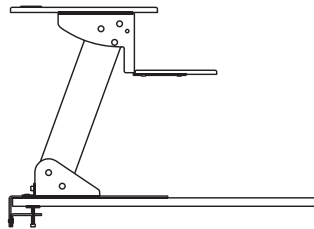

Screw Mount

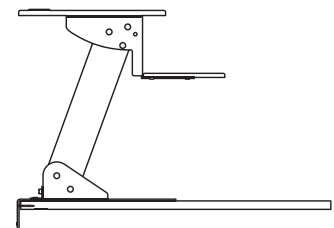

Use when no overhang is available. Worksurface must be minimum 1" thick.



HOW TO SPECIFY

<p>Select Model Number</p> <p>HBXRISER.</p>	<p>Select Finish</p> <p>BLK Black WHT White</p> <p>BLK</p>
--	---

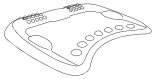
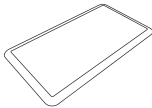
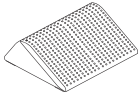

	DESCRIPTION	MODEL	SHIP WEIGHT	CUBE	LIST PRICE
	Rectangle Wobble Board — Anti-Fatigue Mat 18"D x 3"H x 22½"W ⓘ Available in Black (T) finish ONLY. Recommended weight capacity not to exceed 250 pounds. HON 5-Year Limited Warranty. SPECIFYING EXAMPLE: HVL981.T	HVL981	10.0 ⓘ	0.9	\$120
	Round Wobble Board — Anti-Fatigue Mat 18½"D x 2½"H x 18½"W ⓘ Available in Black (T) finish ONLY. Recommended weight capacity not to exceed 250 pounds. HON 5-Year Limited Warranty. SPECIFYING EXAMPLE: HVL982.T	HVL982	5.8 ⓘ	0.6	\$102
	Ergonomic Anti-Fatigue Mat 25"D x 2¾"H x 29⅞"W ⓘ Available in Black ONLY. No specification needed. SPECIFYING EXAMPLE: HBEAFM1	HBEAFM1	7.0	1.4	\$219
	Rectangle Anti-Fatigue Mat 20"D x ¾"H x 36"W ⓘ Available in Black ONLY. No specification needed. SPECIFYING EXAMPLE: HBAFM2036	HBAFM2036	5.4	0.4	\$100
	Footrest — Anti-Slip Cover 13¾"D x 5½"H x 16"W ⓘ Available in Black (T) finish ONLY. Recommended weight capacity not to exceed 250 pounds. HON 5-Year Limited Warranty. SPECIFYING EXAMPLE: HVL991.T	HVL991	7.0 ⓘ	0.9	\$82

HOW TO SPECIFY

Select
Model Number

H V L 9 8 1 .

Select
Finish

T Black

T

MANAGE® SERIES



Manage® Table Desk and Mobile Pedestal shown with HVL531.

MANAGE

Inspired by the needs of small businesses, Manage makes it easy to, well . . . manage your workspace. Whether you're setting up a new office or expanding where you are, Manage is easy to order and install — and to reconfigure as your business needs grow and change. It's thoroughly functional, endlessly flexible, and ready to meet today's fast-paced business demands. Plus, the price is a perfect fit for small-business budgets.



FEATURES

- Remarkable performance at an affordable price.
- Supports open plans, semi-private or private offices.
- Sturdy reinforced steel construction for strength and durability.
- Scratch-, spill- and stain-resistant laminate withstands heavy use.
- Precision metal-to-metal fasteners and wood dowels to provide easy assembly.
- Distinctive, custom-designed metal drawer handles.

MANAGE[®] SERIES

Laminate Desks Worksurfaces

OPEN MARKET

Icon Legend on page 19

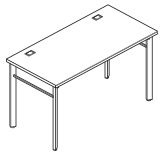
**DESCRIPTION****Table Desk**

60"W x 23½"D
48"W x 23½"D

NOTES: Two cord management grommets in tops.

MODEL

HMNG60WKS
HMNG48WKS

SHIP WEIGHT

78
59 Ⓢ

CUBE

7.3
6.0

LIST PRICE

\$452
\$433

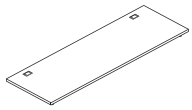
**Worksurface**

72"W x 23½"D

NOTES: Two cord management grommets in tops.

HMNG72WKS

57

5.0

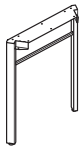
\$300**Desk Leg**

2¼"W x 23½"D x 28½"H

! Specify paint only.

SPECIFYING EXAMPLE: HMNGDLEG.A1

HMNGDLEG

14 Ⓢ

2.0

\$111**NOTES:**

- Non-handed desk design simplifies ordering and supports both left-handed and right-handed users.
- Two factory-installed steel beams reinforce the worksurface for strength and rigidity.
- 1" thick desk top provides a sturdy, durable worksurface.
- Durable, thermal-fused laminate is scratch- and spill-resistant.
- Desk legs have leveling glides to compensate for uneven floors.
- **HON 5-Year Limited Warranty.**

HOW TO SPECIFY**Select Model Number**

HMNG60WKS L .

Select Laminate

C1 Chestnut
WH Wheat
Not specified for model HMNGDLEG

C1 .

Select Paint Color

A1 Ash

A1

Icon Legend on page 19



DESCRIPTION

Pedestals

15¾"W x 21"D x 22"H, Pencil/Pencil/File

NOTES: Pedestal includes two pencil drawers and a file drawer.

MODEL

HMNG15PED

SHIP WEIGHT

69 **Ⓞ**

CUBE

7.0

LIST PRICE

\$388

NOTES:

- Durable, thermal-fused laminate is scratch- and spill-resistant.
- Pedestals ship fully assembled.
- Ball-bearing suspensions on drawers provide full extension and smooth, quiet access to documents.
- **HON 5-Year Limited Warranty.**

HOW TO SPECIFY

Select Model Number

HMNG15PED

Select Laminate

C1 Chestnut
WH Wheat

C1

Select Paint Color

A1 Ash

A1

MANAGE[®] SERIES

Accessories

OPEN MARKET

Icon Legend on page 19

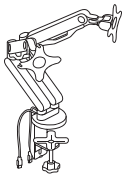
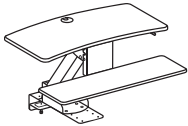
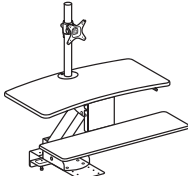
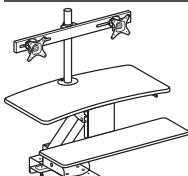
	DESCRIPTION	MODEL	SHIP WEIGHT	CUBE	LIST PRICE
	Coordinate™ Portable Desktop Riser 31"D x 5'-16½"H x 35"W NOTES: Available in Black (BLK) or White (WHT) finish. Desktop riser dimensions (without keyboard tray): 22"D x 5'-16½"H x 35"W. Keyboard tray dimensions: 9"D x 30"W. Max loading capacity is 33 lbs for the desktop riser surface and 4 lbs for the keyboard tray. Easily transition from seated to standing positions throughout the workday. Sits atop an existing desk to create sit-to-stand functionality by raising the computer. Includes keyboard tray and surface for computer monitors. HON 5-Year Limited Warranty. ⓘ Not intended for use on mobile workstations.	HBXRISER	54.0	4.1	\$619
	Dual Monitor Arm with 2 USB Ports NOTES: Easy adjustment. Height adjusts to 17" tall. Monitor tilt and swivel capability. Enclosed cable management. Grommet or desktop mounting. Clean appearance. In some applications the Monitor Arms may extend 12 or more inches into the worksurface. For additional information see page 825. HON 5-Year Limited Warranty. ⓘ No specification needed.	HBDMAUSB	41.9	2.6	\$441
	Coordinate™ Mounted Desktop Riser NOTES: Does not include a monitor arm and is suitable for laptops and/or monitors on their original stands. ⓘ No specification needed.	HS1100	60.0 ⓘ	3.2	\$664
	Coordinate™ Mounted Desktop Riser with Single Monitor Arm NOTES: Includes a monitor arm for a single monitor. ⓘ No specification needed.	HS1101	62.0 ⓘ	3.2	\$777
	Coordinate™ Mounted Desktop Riser with Dual Monitor Arm NOTES: Includes a monitor arm for dual monitors. ⓘ No specification needed.	HS1102	63.0 ⓘ	3.2	\$883

NOTES FOR HS1100, HS1101, HS1102:

- These products are designed to allow the user to transition from seating position to standing position throughout the workday.
- Gas-assist lever-operated mechanism with positive stop.
- Clamp mount compatible with worksurfaces depths of 20"-30". 20" is for systems only.
- Clamp requires 3.5" of clearance along back edge of worksurface.
- Black seamless worksurfaces.
- Silver powder coated metal components.
- Lowers below worksurface level on 24" and 30"D worksurfaces.
- All models contain a large primary worksurface and a smaller keyboard / mouse surface.
- Beveled edges for sleek appearance and comfort while typing.
- Monitor arms include height, width, and swivel adjustment.
- For additional information see page 838.

- Not for use under overhead storage, with flush mounted modesty panels, or worksurfaces thinner than 1".

- ⓘ Not recommended for use on mobile (castered) worksurfaces.

MOUNTING AND COMPATIBILITY FOR HS1100, HS1101, HS1102:

- This product is intended to be installed on commercial-grade worksurfaces in good condition.
- Compatible with freestanding worksurfaces 24"-30"D or panel-supported worksurfaces 24"-30"D.
- Not for use on mobile worksurfaces.

Clamp Mount

Use when 3.5" minimum overhang is available

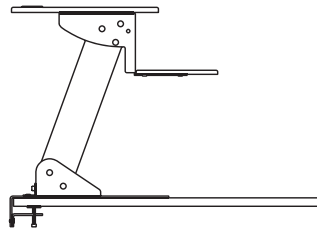

Screw Mount

Use when no overhang is available. Worksurface must be minimum 1" thick.

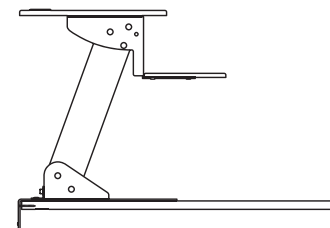



HOW TO SPECIFY

Select Model Number

Select Finish

BLK Black
WHT White

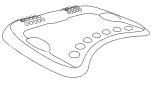
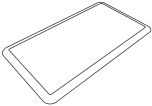
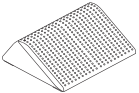

	DESCRIPTION	MODEL	SHIP WEIGHT	CUBE	LIST PRICE
	Rectangle Wobble Board — Anti-Fatigue Mat 18"D x 3"H x 22 ¹ / ₄ "W ⓘ Available in Black (T) finish ONLY. Recommended weight capacity not to exceed 250 pounds. HON 5-Year Limited Warranty. SPECIFYING EXAMPLE: HVL981.T	HVL981	10.0 Ⓢ	0.9	\$120
	Round Wobble Board — Anti-Fatigue Mat 18 ¹ / ₂ "D x 2 ¹ / ₈ "H x 18 ¹ / ₂ "W ⓘ Available in Black (T) finish ONLY. Recommended weight capacity not to exceed 250 pounds. HON 5-Year Limited Warranty. SPECIFYING EXAMPLE: HVL982.T	HVL982	5.8 Ⓢ	0.6	\$102
	Ergonomic Anti-Fatigue Mat 25"D x 2 ³ / ₄ "H x 29 ⁷ / ₈ "W ⓘ Available in Black ONLY. No specification needed. SPECIFYING EXAMPLE: HBEAFM1	HBEAFM1	7.0	1.4	\$219
	Rectangle Anti-Fatigue Mat 20"D x ³ / ₄ "H x 36"W ⓘ Available in Black ONLY. No specification needed. SPECIFYING EXAMPLE: HBAFM2036	HBAFM2036	5.4	0.4	\$100
	Footrest — Anti-Slip Cover 13 ³ / ₄ "D x 5 ¹ / ₂ "H x 16"W ⓘ Available in Black (T) finish ONLY. Recommended weight capacity not to exceed 250 pounds. HON 5-Year Limited Warranty. SPECIFYING EXAMPLE: HVL991.T	HVL991	7.0 Ⓢ	0.9	\$82

HOW TO SPECIFY

<p>Select Model Number</p> <p>H V L 9 8 1 . T</p>	<p>Select Finish</p> <p>T Black</p>
---	-------------------------------------

VALIDO®



Valido® shown with Preside® Conference Table, HON® Occasional Tables, Flock® and Ignition® seating.

VALIDO®

Valido knows how to make them. Impeccable design. Quality craftsmanship. A tailored, signature style that lasts. With precision-machined edges and more than 100 different surface combinations, Valido lets you create a custom-built look with an executive edge. And thanks to a variety of flexible component options — plus high-quality laminate that resists scratches, stains, spills and wear — Valido is the very definition of form meeting function.



FEATURES

- Formal 1½-thick worksurfaces are finished with an elegant, ribbon-edge detail.
- Multiple storage options let you create spaces that work the way you do.
- Valido components are designed to fit, form and grow into every area and any space.
- Metal-to-metal fastening system for precise fit and unsurpassed durability.
- Available in durable mix-and-match laminates, including woodgrain, solid, and pattern colors.
- Four decorative handle options to choose from.

VALIDO® ORDERING INFORMATION

LAMINATE FINISHES AVAILABILITY

L1 LAMINATES CODES

Woodgrain

- ◆ Bourbon Cherry HH
- ◆ Cognac COGNCOGN
- ◆ Florence Walnut LFW1LFW1
- ◆ Harvest CC
- ◆ Kingswood Walnut LK1LK11
- ◆ Mahogany NN
- ◆ Mocha MOCHMOCH
- ◆ Natural Maple DD
- ◆ Pinnacle PINCPINC
- ◆ Shaker Cherry FF
- ◆ Sterling Ash LSA1LSA1

Solid

- ◆ Black PP
- ◆ Charcoal SS
- ◆ Designer White LDW1LDW1

Patterned Top

- ◆ Grey Tigris L6(*)
- ◆ Sheer Mesh A5(*)
- ◆ Silver Mesh B9(*)
- ◆ Canyon Zephyr K9(*)
- ◆ Desert Zephyr K8(*)

(*) Patterned top laminates are available with the following base/edgebanding laminate selection: C, COGN, D, F, H, MOCH, N, P, PINC, S, or WHIT.
Edgebanding will match base laminate selected.

SPECIFYING EXAMPLE: H11592.L6N

The following Valido products are not available as two-tone and require only one color code:

- Modular pedestals — box/file, box/box/file, file/file, lateral file, multi file, and cabinet.

◆◆◆ For lead time information see page 19.

Patterned Top

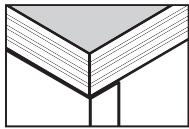

Edgeband Around Top / Laminate Base

- Edgebanding on patterned laminates matches the laminate base selected.
- LAMINATE DESKS
SPECIFY: Model Number.
Laminate
EXAMPLE: H11596.NN
- WORKSURFACES
SPECIFY: Model Number.
Top Laminate
Edgeband
- All specifications in this publication are based on the latest product information available at the time of print.
- ! Tops with a patterned color are not available with a matching edgeband.

Edge Option:

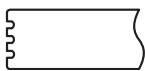

Ribbon Edge "A"

Handle Options:

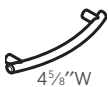

Sweep Designator
Black A
Satin Nickel C

4 5/8"W



Crescent Designator
Black D
Satin Nickel F

5"W



Linear
Black G
Matte Chrome J

5 3/4"W

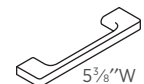

Arch
Black K
Matte Chrome M

5 3/8"W

TWO-TONE LAMINATE TOP / BASE

L1 LAMINATES CODES

Two-Tone Top/Base

- ◆ Black/Charcoal PS
- ◆ Black/Designer White ... PLDW1
- ◆ Bourbon Cherry/Black HP
- ◆ Bourbon Cherry/Charcoal ... HS
- ◆ Bourbon Cherry/Designer
White HLDW1
- ◆ Charcoal/Black SP
- ◆ Charcoal/Designer
White SLDW1
- ◆ Cognac/Black COGNP
- ◆ Cognac/Charcoal COGNS
- ◆ Cognac/Designer
White COGNLDW1
- ◆ Designer White/Black ... LDW1P
- ◆ Designer White/Bourbon
Cherry LDW1H
- ◆ Designer
White/Charcoal LDW1S
- ◆ Designer
White/Cognac LDW1COGN
- ◆ Designer
White/Harvest LDW1C
- ◆ Designer
White/Mahogany LDW1N
- ◆ Designer
White/Mocha LDW1MOCH
- ◆ Designer White/Natural
Maple LDW1D
- ◆ Designer
White/Pinnacle LDW1PINC
- ◆ Designer White/Shaker
Cherry LDW1F
- ◆ Florence Walnut/Black . LFW1P
- ◆ Florence
Walnut/Charcoal LFW1S

◆◆◆ For lead time information see page 19.

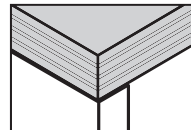

Laminate Base

Two-tone laminates: Top and edgebanding are the same, base is different laminate color.

- Edgebanding on two-tone laminates matches top, base is a different laminate color.
- A complete selection of Conference Room and Occasional Tables is shown under Tables on pages 714-716, 718-719, 722, and 734-750.
- LAMINATE DESKS
SPECIFY: Model Number.
Laminate
EXAMPLE: H11596.HP
- All specifications in this publication are based on the latest product information available at the time of print.

TWO-TONE LAMINATE TOP / BASE *continued*

L1 LAMINATES CODES

Two-Tone Top/Base

- ◆ Florence Walnut/Designer
White LFW1LDW1
- ◆ Harvest/Black CP
- ◆ Harvest/Charcoal CS
- ◆ Harvest/Designer
White CLDW1
- ◆ Kingswood
Walnut/Black LK11P
- ◆ Kingswood
Walnut/Charcoal LK11S
- ◆ Kingswood Walnut/Designer
White LK11LDW1
- ◆ Mahogany/Black NP
- ◆ Mahogany/Charcoal NS
- ◆ Mahogany/Designer
White NLDW1
- ◆ Mocha/Black MOCHP
- ◆ Mocha/Charcoal MOCHS
- ◆ Mocha/Designer
White MOCHLDW1
- ◆ Natural Maple/Black DP
- ◆ Natural Maple/Charcoal DS
- ◆ Natural Maple/Designer
White DLDW1
- ◆ Pinnacle/Black PINCP
- ◆ Pinnacle/Charcoal PINCS
- ◆ Pinnacle/Designer
White PINCLDW1
- ◆ Shaker Cherry/Black FP
- ◆ Shaker Cherry/Charcoal FS
- ◆ Shaker Cherry/Designer
White FLDW1
- ◆ Sterling Ash/Black LSA1P
- ◆ Sterling Ash/Charcoal LSA1S
- ◆ Sterling Ash/Designer
White LSA1LDW1



Components used are listed on pages 141-163. Order components individually. Other configurations are possible, including various sizes of some components.

QTY	DESCRIPTION	MODEL	LIST PRICE	PRICE EXTENSION
1	Double Pedestal Desk - 2/2 72"W x 36"D x 29½"H	H11593	\$1,795	\$1,795
1	Credenza with Kneespace - 2/2 72"W x 24"D x 29½"H	H11543	\$1,663	\$1,663
1	Stack-on Storage 72"W x 14⅝"D x 37½"H	H11534	\$1,291	\$1,291
2	Vertical Paper Manager	HLVPM1	\$327	\$654
TOTAL:			\$5,403	

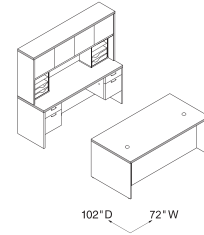

DESK/CREDENZA
72"W x 102"D

QTY	DESCRIPTION	MODEL	LIST PRICE	PRICE EXTENSION
1	Double Pedestal Bow Top Desk - 2/2 72"W x 36"D x 29½"H	H11595	\$1,959	\$1,959
1	Credenza with Kneespace - 2/2 72"W x 24"D x 29½"H	H115900	\$2,067	\$2,067
1	Stack-on Storage 72"W x 14⅝"D x 37½"H	H11534	\$1,291	\$1,291
1	Personal Wardrobe/Storage Cabinet, Left 18"W x 24"D x 67"H	H115296L	\$1,777	\$1,777
1	Storage/File Cabinet, Right 18"W x 24"D x 67"H	H115297R	\$2,055	\$2,055
TOTAL:			\$9,149	

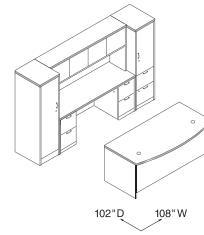

DESK/CREDENZA
108"W x 102"D

QTY	DESCRIPTION	MODEL	LIST PRICE	PRICE EXTENSION
1	Single Pedestal Desk, Left - B/F 72"W x 36"D x 29½"H	H11586L	\$1,525	\$1,525
1	Return, Right - B/F 48"W x 24"D x 29½"H	H11515R	\$1,110	\$1,110
1	Stack-on Storage 48"W x 14⅝"D x 37½"H	H115323	\$1,049	\$1,049
1	Square End Cap Bookshelf 24"W x 24"D x 29½"H	H115525R	\$752	\$752
TOTAL:			\$4,436	

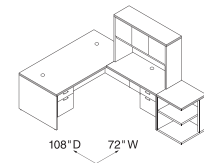

"L" WORKSTATION
72"W x 108"D

QTY	DESCRIPTION	MODEL	LIST PRICE	PRICE EXTENSION
1	Single Pedestal Desk, Left - B/F 66"W x 30"D x 29½"H	H11584L	\$1,426	\$1,426
1	Return, Right - B/F 48"W x 24"D x 29½"H	H11515R	\$1,110	\$1,110
1	Stack-on Storage 78"W x 14⅝"D x 37½"H	H115327	\$1,437	\$1,437
1	Vertical Paper Manager	HLVPM1	\$327	\$327
1	End Cap Bookshelf 24"W x 24"D x 29½"H	H115520	\$763	\$763
1	End Cap Bookshelf 15"W x 15"D x 37½"H	H115523	\$675	\$675
TOTAL:			\$5,738	

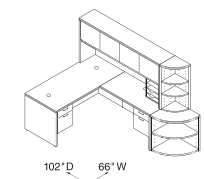

"L" WORKSTATION
66"W x 102"D



Icon Legend on page 19

Components used are listed on pages 141-163. Order components individually. Other configurations are possible, including various sizes of some components.

QTY	DESCRIPTION	MODEL	LIST PRICE	PRICE EXTENSION
1	Single Pedestal Desk, Right - B/F 72"W x 36"D x 29½"H	H11585R	\$1,525	\$1,525
1	Bridge 47"W x 24"D x 29½"H	H11570	\$505	\$505
1	Credenza with 36" Lateral, Left 72"W x 24"D x 29½"H	H11548L	\$1,784	\$1,784
1	Stack-on Storage 72"W x 14⅝"D x 37½"H	H11534	\$1,291	\$1,291
1	Storage Cabinet/Lateral File 36"W x 24"D x 67"H	H115293	\$2,665	\$2,665
TOTAL:			\$7,770	

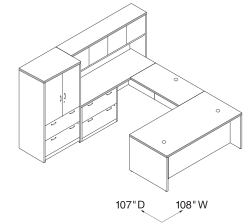

"U" WORKSTATION
108"W x 107"D

QTY	DESCRIPTION	MODEL	LIST PRICE	PRICE EXTENSION
1	Single Full Pedestal Bow Front Desk 72"W x 36"D x 29½"H	H115893R	\$2,139	\$2,139
1	Bridge 42"W x 24"D x 29½"H	H11560	\$483	\$483
1	Left Single Full Pedestal Credenza 72"W x 24"D x 29½"H	H115904L	\$1,701	\$1,701
1	Stack-on Storage 72"W x 14⅝"D x 37½"H	H11534	\$1,291	\$1,291
1	Vertical Paper Manager	HLVPM1	\$327	\$327
1	Personal Wardrobe/Storage Cabinet 36"W x 24"D x 67"H	H11530	\$2,603	\$2,603
TOTAL:			\$8,544	

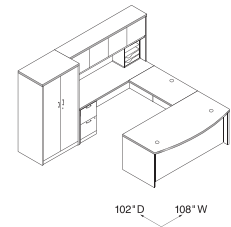

"U" WORKSTATION
108"W x 102"D

QTY	DESCRIPTION	MODEL	LIST PRICE	PRICE EXTENSION
1	Single Pedestal Bow Front Desk, Right - B/F 72"W x 36"D x 29½"H	H11587R	\$1,727	\$1,727
1	Bridge 36"W x 24"D x 29½"H	H115599	\$483	\$483
1	36" Corner Unit	H115811	\$902	\$902
1	Return, Left 42"W x 24"D x 29½"H	H11512L	\$1,097	\$1,097
1	Stack-on Storage 78"W x 14⅝"D x 37½"H	H115327	\$1,437	\$1,437
1	Vertical Paper Manager	HLVPM1	\$327	\$327
1	Personal Storage Tower 24"W x 24"D x 67"H	H115301R	\$2,603	\$2,603
TOTAL:			\$8,576	

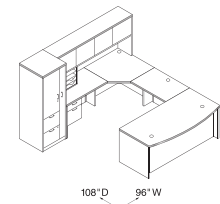

"U" WORKSTATION
102"W x 108"D

QTY	DESCRIPTION	MODEL	LIST PRICE	PRICE EXTENSION
1	Extended Corner Unit, Left 24"D x 72"W x 36"D x 24"W x 29½"H	H115816L	\$1,308	\$1,308
1	Box/Box/File Mobile Pedestal 15⅝"W x 22¾"D x 28"H	H115102	\$939	\$939
1	Stack-on Storage 72"W x 14⅝"D x 37½"H	H11534	\$1,291	\$1,291
1	Vertical Paper Manager	HLVPM1	\$327	\$327
1	Return Shell (with Full Modesty Panel) 48"W x 24"D x 29½"H	H11561	\$689	\$689
1	File/File Mobile Pedestal 15⅝"W x 22¾"D x 28"H	H115104	\$939	\$939
TOTAL:			\$5,493	

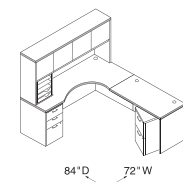

MODULAR "L" WORKSTATION
72"W x 84"D



Components used are listed on pages 141-163. Order components individually. Other configurations are possible, including various sizes of some components.

QTY	DESCRIPTION	MODEL	LIST PRICE	PRICE EXTENSION
1	Jetty Peninsula, Left 72"W x 42"/30"D x 29½"H	H115202L	\$1,394	\$1,394
1	File/File Mobile Pedestal 15⅝"W x 22¾"D x 28"H	H115104	\$939	\$939
1	Return Shell 72"W x 24"D x 29½"H	H115686	\$900	\$900
1	Multi File Pedestal 36"W x 20"D x 28"H	H11505	\$1,406	\$1,406
2	Wall Mounted Storage Cabinet 42"W x 14⅝"D x 18⅞"H	H115382	\$988	\$1,976
1	Wall Mounted Storage Cabinet 30"W x 14⅝"D x 18⅞"H	H115380	\$872	\$872
1	End Cap Bookshelf 24"W x 24"D x 29½"H	H115520	\$763	\$763
TOTAL:			\$8,250	

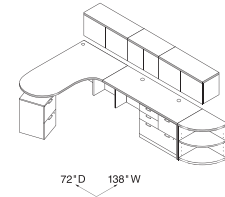

MODULAR "L" WORKSTATION
138" W x 72" D

QTY	DESCRIPTION	MODEL	LIST PRICE	PRICE EXTENSION
1	Storage/File Cabinet, Left 18"W x 24"D x 67"H	H115298L	\$2,055	\$2,055
1	Return Shell 72"W x 24"D x 29½"H	H115686	\$900	\$900
1	File/File Modular Pedestal 15⅝"W x 22¾"D x 28"H	H11504	\$767	\$767
1	Mobile Printer/Fax Cart 20"W x 19⅞"D x 14⅞"H	H105679	\$420	\$420
1	Stack-on Storage 72"W x 14⅝"D x 37½"H	H11534	\$1,291	\$1,291
1	Vertical Paper Manager	HLVPM1	\$327	\$327
1	36" Corner Unit	H115811	\$902	\$902
1	Stack-on Storage 36"W x 14⅝"D x 37½"H	H115321	\$865	\$865
1	Return Shell 60"W x 24"D x 29½"H	H115684	\$841	\$841
1	Multi File Pedestal 36"W x 20"D x 28"H	H11505	\$1,406	\$1,406
TOTAL:			\$9,774	

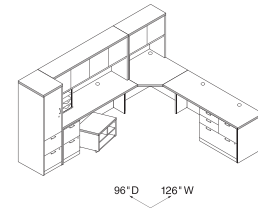

MODULAR "L" CORNER WORKSTATION
126" W x 96" D

QTY	DESCRIPTION	MODEL	LIST PRICE	PRICE EXTENSION
1	Boomerang Peninsula, Left 72"W x 42"/30"D x 29½"H	H115204L	\$1,394	\$1,394
1	Box/Box/File Mobile Pedestal 15⅝"W x 22¾"D x 28"H	H115102	\$939	\$939
1	Bridge 30"W x 24"D x 29½"H	H115598	\$483	\$483
1	Extended Corner Unit, Right 24"W x 36"D x 72"W x 24"D x 29½"H	H115815R	\$1,308	\$1,308
1	File/File Modular Pedestal 15⅝"W x 22¾"D x 28"H	H11504	\$767	\$767
1	Stack-on Storage 72"W x 14⅝"D x 37½"H	H11534	\$1,291	\$1,291
1	Storage/File Cabinet, Right 18"W x 24"D x 67"H	H115297R	\$2,055	\$2,055
1	End Cap Bookshelf 24"W x 24"D x 67"H	H115524	\$1,213	\$1,213
TOTAL:			\$9,450	

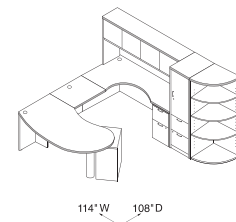

MODULAR "U" WORKSTATION
114" W x 108" D



Icon Legend on page 19

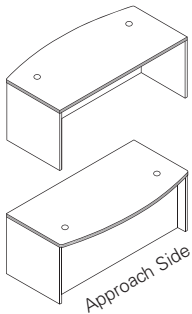

Model H11596 shown

DESCRIPTION

Desk Shell (with Full Modesty Panel)

72"W x 36"D x 29½"H, Bow Top (end panels 30"D)
72"W x 36"D x 29½"H, Rectangle Top
72"W x 30"D x 29½"H, Rectangle Top
66"W x 30"D x 29½"H, Rectangle Top
60"W x 30"D x 29½"H, Rectangle Top
48"W x 30"D x 29½"H, Rectangle Top (1 grommet)

INSIDE DIMENSIONS	FULL WIDTH OVERHANG	MODEL	SHIP WEIGHT	SHIP CUBE	LIST PRICE
69½"W x 24⅝"D	10½"	H11596	218	5.8	\$1068
69½"W x 24⅝"D	10½"	H11594	239	5.8	\$1023
69½"W x 24⅝"D	4½"	H11592	206	6.6	\$954
63½"W x 24⅝"D	4½"	H11579	194	4.5	\$900
57½"W x 24⅝"D	4½"	H11578	182	4.1	\$862
45½"W x 24⅝"D	4½"	H11598	154	4.0	\$814

NOTES: See page 161 for optional center drawers.

NOTES:

- Non-handed desk, credenza, and return shells, combined with a variety of under-the-worksurface storage solutions, maximize office layout flexibility. Shells and pedestals can be reconfigured quickly and easily when user preferences or space needs change.
- Tops are abrasion- and stain-resistant laminate over extra-thick 1½" solid core high-performance particleboard; resists warping.
- "Ribbon" edge profile; shape is on all four sides.
- Full height modesty panels.
- Cord management grommets, for routing and hiding wires and cables, are located in the tops of desk and return shells.
- 3" round worksurface grommet can be replaced with optional Power Hub (model HGRMTAC) or Power/USB Hub (model HGRMTUSB2) to bring the ease of plug-and-play to the desktop. See page 165.
- Credenza shells have a cord pass-through grommet in the top center of the modesty panel.
- The narrow design of the kneespace clearance end panel kits replace full end panels to provide added kneespace.
- Adjustable hex leveling glides allow floor-standing furniture to be easily leveled; glides have ¾" adjustable range.
- For conference table options, see the Preside® table tops and bases on pages 774-779. Order edge option "K".
- See pages 144-145 for modular storage components.

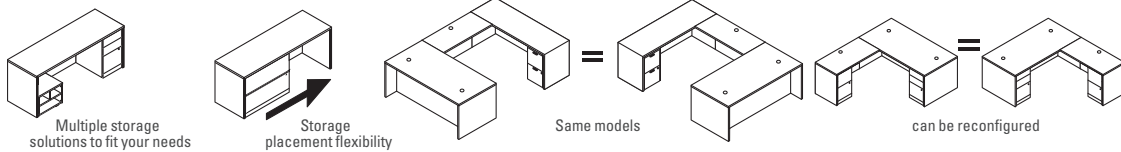

HOW TO SPECIFY

<p>Select Model Number</p> <p>H 1 1 5 9 6</p>	<p>Select Edge Profile</p> <p>See page 137</p> <p>A</p>	<p>Select Laminate</p> <p>See page 137</p> <p>NN</p>
--	--	---

VALIDO® Modular Credenzas

GSA SIN 33721



Icon Legend on page 19

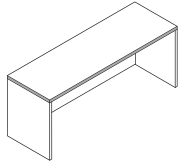

Model H11541 shown

DESCRIPTION**24" D Credenza Shell (with Full Modesty Panel)**

72"W x 24"D x 29½"H
66"W x 24"D x 29½"H
60"W x 24"D x 29½"H
48"W x 24"D x 29½"H
42¼"W x 24"D x 29½"H

**INSIDE
DIMENSIONS**

69½"W x 22¾"D
63½"W x 22¾"D
57½"W x 22¾"D
45½"W x 22¾"D
39¾"W x 22¾"D

MODEL

H11541
H11542
H11564
H115692
H115691

**SHIP
WEIGHT**

169
159
148
135
118

CUBE

4.5
4.2
3.8
2.8
3.4

**LIST
PRICE**

\$900
\$875
\$841
\$791
\$752

NOTES: Cord pass-through grommet in top center of modesty panel. See pages 153-154 for optional stack-on storage.

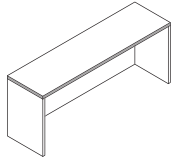
**20" D Credenza Shell (with Full Modesty Panel)**

72"W x 20"D x 29½"H
66"W x 20"D x 29½"H
60"W x 20"D x 29½"H

69½"W x 18¾"D
63½"W x 18¾"D
57½"W x 18¾"D

H115581
H115582
H115583

154
145
135

5.3
4.8
4.4

\$852
\$826
\$796

NOTES: Cord pass-through grommet in top center of modesty panel. See pages 153-154 for optional stack-on storage.

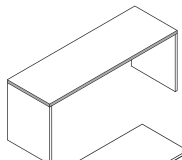
**24" D Credenza Shell (with 10" Modesty Panel)**

72"W x 24"D x 29½"H
66"W x 24"D x 29½"H
60"W x 24"D x 29½"H
48"W x 24"D x 29½"H
42¼"W x 24"D x 29½"H

69½"W x 22¾"D
63½"W x 22¾"D
57½"W x 22¾"D
45½"W x 22¾"D
39¾"W x 22¾"D

H11541X
H11542X
H11564X
H115692X
H115691X

162
124
120
107
98

5.0
4.0
4.0
4.0
4.0

\$900
\$875
\$841
\$791
\$752

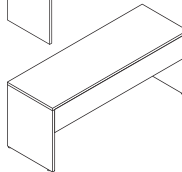
**20" D Credenza Shell (with 10" Modesty Panel)**

72"W x 20"D x 29½"H
66"W x 20"D x 29½"H
60"W x 20"D x 29½"H

69½"W x 18¾"D
63½"W x 18¾"D
57½"W x 18¾"D

H115581X
H115582X
H115583X

124
117
110

4.6
4.2
3.8

\$852
\$826
\$796

NOTES: Makes reaching wall electrical outlets quick and easy. Provides more than 18" of clearance. See pages 153-154 for optional stack-on storage.



Not available in two-tone laminate

Kneespace Clearance End Panel Kits (field installable)

1½"W x 11¼"D x 28⅞"H

H105098

13

0.9

\$210

For use at either end of Valido, 10500 or 10700 Series™ 24" D Credenza Shells (with full or 10" modesty panel) or non-pedestal end of single pedestal credenzas or credenzas with lateral files.

1⅞"W x 17¼"D x 28⅞"H

H105099

11

0.8

\$220

For use at either end of Valido, 10500 or 10700 Series™ 30" D Desk Shells or non-pedestal end of 30" D single pedestal desks.

Kits include: (1) support panel; European fastening hardware; flat connector bracket; joint connector bolts with sleeve nuts (for ganging credenza to adjacent worksurface); and adjustable leveling glides. Allows conversion of units currently in the field.

NOTES: Can be used to connect up to three 24" D credenzas or 30" D desks in line (requires 4 kits).

⚠ Not designed to be used freestanding. Not designed to be used with returns, 36" D desks or desk shells.

SPECIFYING EXAMPLE: H105098.N**NOTES:**

- Non-handed desk, credenza, and return shells, combined with a variety of under-the-worksurface storage solutions, maximize office layout flexibility. Shells and pedestals can be reconfigured quickly and easily when user preferences or space needs change.
- Tops are abrasion- and stain-resistant laminate over extra-thick 1½" solid core high-performance particleboard; resists warping.
- "Ribbon" edge profile; shape is on all four sides.
- Cord management grommets, for routing and hiding wires and cables, are located in the tops of desk and return shells.
- Credenza shells have a cord pass-through grommet in the top center of the modesty panel.
- The narrow design of the kneespace clearance end panel kits replace full end panels to provide added kneespace.
- Adjustable hex leveling glides allow floor-standing furniture to be easily leveled; glides have ¾" adjustable range.
- Credenza Shells available with Full or 10" Modesty Panel options.
- For conference table options, see the Preside® table tops and bases on pages 774-779. Order edge option "K".
- See pages 144-145 for modular storage components.

HOW TO SPECIFY**Select
Model Number**

H 1 1 5 4 1 .

**Select
Edge Profile**

See page 137

A .

**Select
Laminate**

See page 137

N N



Icon Legend on page 19

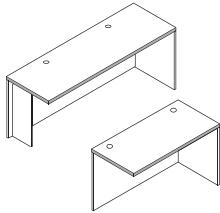

Model H115686 shown

DESCRIPTION

- 24" D Return Shell (with Full Modesty Panel)**
 72"W x 24"D x 29½"H, (w/support; 2 grommets)
 60"W x 24"D x 29½"H, (w/support; 2 grommets)
 48"W x 24"D x 29½"H, (1 grommet)
 42"W x 24"D x 29½"H, (1 grommet)
 36"W x 24"D x 29½"H, (1 grommet)
 30"W x 24"D x 29½"H, (1 grommet)

INSIDE DIMENSIONS	MODEL	SHIP WEIGHT	CUBE	LIST PRICE
67"W x 22¾"D	H115686	161	5.4	\$900
55"W x 22¾"D	H115684	142	4.9	\$841
47"W x 22¾"D	H11561	97	3.2	\$689
41"W x 22¾"D	H115681	97	2.5	\$674
34⅞"W x 22¾"D	H115680	91	3.2	\$674
28⅞"W x 22¾"D	H11568	78	2.8	\$625

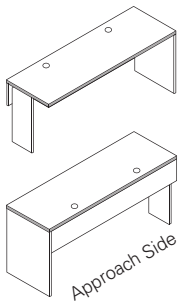

24" D Return Shell (with 10" Modesty Panel)

- 72"W x 24"D x 29½"H
 60"W x 24"D x 29½"H
 48"W x 24"D x 29½"H
 42"W x 24"D x 29½"H
 36"W x 24"D x 29½"H
 30"W x 24"D x 29½"H

67"W x 22¾"D	H115686X	124	5.0	\$900
55"W x 22¾"D	H115684X	108	4.0	\$841
47"W x 22¾"D	H11561X	90	3.0	\$689
41"W x 22¾"D	H115681X	80	3.0	\$674
34⅞"W x 22¾"D	H115680X	76	3.0	\$674
28⅞"W x 22¾"D	H11568X	65	2.8	\$625

NOTES: Shells are non-handed. No pre-drilled grommet in modesty panel (field installable grommet included). Woodgrain direction on modesty/back panel runs vertical on 30"W-60"W sizes and horizontal on 72"W unit. 36"W return shell can be used to achieve an efficient 6' x 6' footprint when connected to either a 72"W x 36"D single pedestal desk, desk shell, or peninsula, or when two are connected to a 36"W corner unit model H115811. 30"W return shell can be used to accomplish a 5' x 5' footprint when connected to a 60"W x 30"D desk shell or peninsula. See pages 153-154 for optional stack-on storage.

NOTES:

- Non-handed desk, credenza, and return shells, combined with a variety of under-the-worksurface storage solutions, maximize office layout flexibility. Shells and pedestals can be reconfigured quickly and easily when user preferences or space needs change.
- Tops are abrasion- and stain-resistant laminate over extra-thick 1½" solid core high-performance particleboard; resists warping.
- "Ribbon" edge profile; shape is on all four sides.
- Cord management grommets, for routing and hiding wires and cables, are located in the tops of desk and return shells.
- Credenza shells have a cord pass-through grommet in the top center of the modesty panel.
- The narrow design of the kneespace clearance end panel kits replace full end panels to provide added kneespace.
- Adjustable hex leveling glides allow floor-standing furniture to be easily leveled; glides have ¾" adjustable range.
- Credenza Shells available with Full or 10" Modesty Panel options.
- For conference table options, see the Preside® table tops and bases on pages 774-779. Order edge option "K".
- For work-in-process paper management tools, see page 162.
- See pages 144-145 for modular storage components.

HOW TO SPECIFY

<p>Select Model Number</p> <p>H 1 1 5 6 8 6</p>	<p>Select Edge Profile</p> <p>See page 137</p> <p>A</p>	<p>Select Laminate</p> <p>See page 137</p> <p>NN</p>
--	--	---

VALIDO® Laminate Modular Components

GSA SIN 33721



Icon Legend on page 19

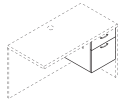

Not available in two-tone laminate

DESCRIPTION**MODEL****SHIP WEIGHT****CUBE****LIST PRICE****Box/File Pedestal (with core removable lock)**15⁵/₈"W x 22³/₄"D x 17³/₄"H**H11501**

57

5.5

\$593

NOTES: For use under 24"D, 30"D and 36"D desk, credenza and return shells. Hangrails included. Lock can be positioned on either the right or left side. Attaches to underside of worksurface top. **Unfinished top and back.**

⚠ Not designed to be used freestanding.

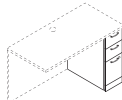

Not available in two-tone laminate

Narrow Box/Box/File Pedestal — floor-standing9¹/₂"W x 22³/₄"D x 28"H**H115093**

61

5.6

\$756

NOTES: For use under 24"D, 30"D and 36"D modular desk, credenza and return shells. Unfinished top and back.

⚠ Handle choices for this model are the Sweep, Crescent and Arch designs only. The linear handle (options "G" and "J") is not available on this product as the width of the component interferes with lock on the drawer face.

⚠ Not designed to be used freestanding.

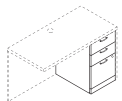

Not available in two-tone laminate

Box/Box/File Pedestal (with core removable lock) — floor-standing15⁵/₈"W x 22³/₄"D x 28"H — for use under 24"D, 30"D and 36"D desk, credenza and return shells**H11502**

90

8.4

\$76715⁵/₈"W x 18³/₄"D x 28"H — for use under 20"D, 24"D, 30"D and 36"D desk, credenza and return shells**H115012**

73

7.0

\$723

NOTES: Top box drawer does not lock. Hangrails included. **Unfinished top and back.**

⚠ Not designed to be used freestanding.

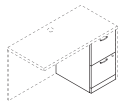

Not available in two-tone laminate

File/File Pedestal (with core removable lock) — floor-standing15⁵/₈"W x 22³/₄"D x 28"H — for use under 24"D, 30"D and 36"D desk, credenza and return shells**H11504**

85

8.4

\$76715⁵/₈"W x 18³/₄"D x 28"H — for use under 20"D, 24"D, 30"D and 36"D desk, credenza and return shells**H115014**

72

7.0

\$723

NOTES: Hangrails included. **Unfinished top and back.**

⚠ Not designed to be used freestanding.

NOTES:

- Pedestals can be reconfigured quickly and easily when user preferences or space needs change.
- File drawers accept hanging folders in letter or legal size.
- Narrow pedestal features a compact design that is ideal for use in U- and L-shaped layouts for smaller spaces, such as a 5' x 8' U-shaped workstation or a 5' x 5' L-shaped workstation.
- Pedestal drawers operate on full extension, ball-bearing suspensions to ensure smooth, quiet, long-lasting operation.
- Handle options shown on page 137.
- Pedestal sides are notched to enable the routing of cords and cables.
- Mobile pedestals shown on page 157, work well in a variety of configurations.
- Pedestal models ship assembled unless designated .
- Modular pedestals to be used with 24"D, 30"D and 36"D Modular Shells.
- Pedestal models not designed to be used freestanding.
- See pages 141-143 for desk, credenza and return shells.

HOW TO SPECIFY**Select Model Number**

H 1 1 5 0 1 .

Select Handle Option

Linear handles "G" and "J" not available on model H115093
See page 137

C .

Select Laminate

See page 137

N

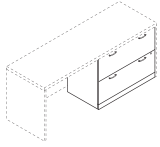

Not available in two-tone laminate

DESCRIPTION

Lateral File Pedestal (with core removable lock) — floor-standing

36"W x 20"D x 28"H — for use under 24"D, 30"D and 36"D desk, credenza and return shells

MODEL **SHIP WEIGHT** **CUBE** **LIST PRICE**

H11503 127 15.6 **\$1179**

NOTES: Hangrails included. **Unfinished top and back.** Mechanical interlock inhibits extension of more than one drawer at a time.

⚠ Not designed to be used freestanding.

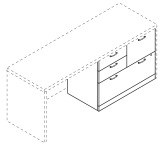

Not available in two-tone laminate

Multi File Pedestal (with core removable lock) — floor-standing

36"W x 20"D x 28"H — for use under 24"D, 30"D and 36"D desk, credenza and return shells

H11505 155 15.6 **\$1406**

NOTES: Versatile four drawer unit features one lateral file drawer, one vertical file drawer, and two box drawers. Box drawers do not lock. Hangrails included. **Unfinished top and back.** Mechanical interlock in lateral drawer inhibits extension of more than one drawer at a time.

⚠ Not designed to be used freestanding.

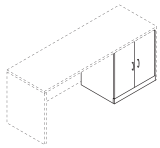

Not available in two-tone laminate

Cabinet Pedestal — floor-standing

26"W x 21¼"D x 28"H — for use under 24"D, 30"D and 36"D desk, credenza and return shells

H11508 78 12.2 **\$855**

NOTES: One adjustable shelf at 2½" increments. Doors are non-locking. **Unfinished top and back.**

⚠ Not designed to be used freestanding.

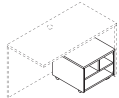

Mobile Printer/Fax Cart

20"W x 19⅞"D x 14⅞"H

H105679 52 2.9 **\$420**

NOTES: Holds laser printers, inkjet printers or fax machines. Ideal for limited space. Low profile cart stores conveniently and easily under desks and workstations. Interior compartment shelving is Black. Four casters. 1⅞" **thick top with flat, non-profiled edge.**

SPECIFYING EXAMPLE: H105679.NN

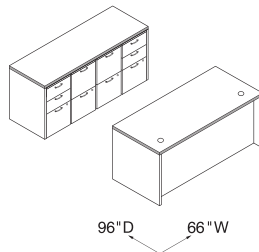

- 1 – H11579
- 1 – H11542
- 2 – H115102
- 2 – H115104

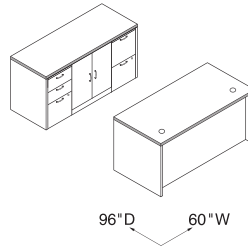

- 1 – H11578
- 1 – H11564
- 1 – H11502
- 1 – H11504
- 1 – H11508

NOTES:

- Pedestals can be reconfigured quickly and easily when user preferences or space needs change.
- See page 137 for handle design/finish options.
- File drawers accept hanging folders in letter or legal size.
- Pedestal drawers operate on full extension, ball-bearing suspensions to ensure smooth, quiet, long-lasting operation.
- Pedestal sides are notched to enable the routing of cords and cables.
- Mobile pedestals shown on page 157, work well in a variety of configurations.
- Pedestal models ship assembled unless designated
- See pages 141-143 for desk, credenza and return shells.

HOW TO SPECIFY

<p>Select Model Number</p> <p>H 1 1 5 0 3</p>	<p>Select Handle Option</p> <p>See page 137 Not specified for model H105679</p> <p>C</p>	<p>Select Laminate</p> <p>See page 137</p> <p>N</p>
--	---	--

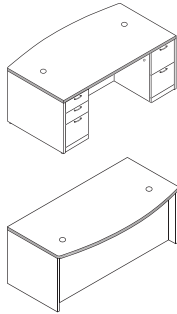
**DESCRIPTION****Double Pedestal Desk, 3/2**

72"W x 36"D x 29½"H, Bow Top	10½"	H115899	362	52.2	\$2438
72"W x 36"D x 29½"H, Rectangle Top	10½"	H115890	370	52.2	\$2319
66"W x 30"D x 29½"H, Rectangle Top	4½"	H115891	312	40.9	\$2231
60"W x 30"D x 29½"H, Rectangle Top	4½"	H115892	303	37.3	\$2119

NOTES: All drawers lock. Two worksurface grommets to route/hide cords. See page 161 for optional center drawers. Bow top model measures 36"D at the crest and 30" along the end panels.

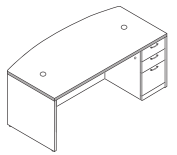
**Single Pedestal Desk, Bow Top**

72"W x 36"D x 29½"H, Right	10½"	H115893R	308	52.2	\$2139
72"W x 36"D x 29½"H, Left	10½"	H115894L	308	52.2	\$2139

NOTES: Box/box/file drawer configuration. Drawers lock. Two worksurface grommets to route/hide cords. See page 161 for optional center drawers. Bow top model measures 36"D at the crest and 30" along the end panels.

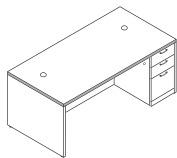
**Single Pedestal Desk, Rectangle Top**

72"W x 36"D x 29½"H, Right	10½"	H115895R	316	52.2	\$2001
66"W x 30"D x 29½"H, Right	4½"	H115897R	269	40.9	\$1818
72"W x 36"D x 29½"H, Left	10½"	H115896L	316	52.2	\$2001
66"W x 30"D x 29½"H, Left	4½"	H115898L	269	40.9	\$1818

NOTES: Box/box/file drawer configuration. Drawers lock. Two worksurface grommets to route/hide cords. See page 161 for optional center drawers.

NOTES:

- Full pedestal design provides a more formal styling aesthetic and maximizes storage space.
- Drawers in pedestal extend from underside of worksurface to the floor.
- Tops are abrasion- and stain-resistant laminate over extra-thick 1½" solid core high-performance particleboard; resists warping.
- 3" round worksurface grommet can be replaced with optional Power Hub (model HGRMTAC) or Power/USB Hub (model HGRMTUSB2) to bring the ease of plug-and-play to the desktop. See page 165.
- Recessed modesty panel design facilitates conferencing. See approach side illustration at left.
- Full height modesty panels.
- Drawers operate on full extension, ball-bearing suspensions to ensure smooth, quiet, long-lasting operation.
- See page 137 for handle design/finish options.
- File drawer design includes integrated hangrails for side-to-side letter or legal filing; and front-to-back for letter filing.
- All drawers are 5-sided construction, which allows easy drawer alignment or replacement of drawer fronts.
- Desk, credenza and return models ship assembled.
- For conference table options, see the Preside® table tops and bases on pages 774-779. Order edge option "K".
- See pages 150-166 for shared components.

HOW TO SPECIFY

Select Model Number	Select Edge Profile	Select Handle Option	Select Laminate
See page 137	See page 137	See page 137	See page 137
H 1 1 5 8 9 9 .	A .	C .	NN

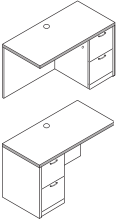
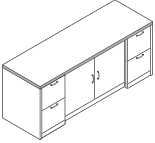
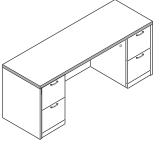
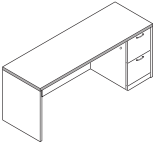

	DESCRIPTION	FULL WIDTH OVERHANG	MODEL	SHIP WEIGHT	CUBE	LIST PRICE
	Return, File/File					
	48"W x 24"D x 29½"H, Right		H115905R	168	24.9	\$1328
	42"W x 24"D x 29½"H, Right		H115907R	159	20.5	\$1314
	48"W x 24"D x 29½"H, Left		H115906L	168	24.9	\$1328
	42"W x 24"D x 29½"H, Left		H115908L	159	20.5	\$1314
	NOTES: Return is for use with single pedestal desks, desk shells, peninsulas or corner units. Drawers lock. One worksurface grommet and one cord pass-through grommet in top center of modesty panel to reach wall electrical outlets. See pages 153-154 for optional stack-on storage.					
	Credenza with Doors					
	72"W x 24"D x 29½"H	3½"	H115909	340	36.0	\$2428
	NOTES: All drawers lock. Doors are non-locking. One cord pass-through grommet in top center of modesty panel. Includes a fixed shelf located at the bottom of the center storage area. No intermittent shelf. See pages 153-154 for optional stack-on storage.					
	Credenza with Kneespace — 2/0/2					
	72"W x 24"D x 29½"H	3½"	H115900	296	36.0	\$2067
	66"W x 24"D x 29½"H	3½"	H115901	286	31.6	\$1967
	60"W x 24"D x 29½"H	3½"	H115902	257	28.8	\$1904
	NOTES: All drawers lock. One cord pass-through grommet in top center of modesty panel. See pages 153-154 for optional stack-on storage.					
	ⓘ Not designed to be used with Valido/11500 Series 22¾"D modular or mobile pedestals. Modesty/back panel is inset 3½".					
	Single Pedestal Credenza, File/File					
	72"W x 24"D x 29½"H, Right (shown)	3½"	H115903R	251	36.0	\$1701
	72"W x 24"D x 29½"H, Left	3½"	H115904L	251	36.0	\$1701
	NOTES: Drawers lock. One cord pass-through grommet in top center of modesty panel. See pages 153-154 for optional stack-on storage.					
	ⓘ Not designed to be used with Valido/11500 Series 22¾"D modular or mobile pedestals. Modesty/back panel is inset 3½".					

NOTES:

- Full pedestal design provides a more formal styling aesthetic and maximizes storage space.
- Drawers in pedestal extend from underside of worksurface to the floor.
- Tops are abrasion- and stain-resistant laminate over extra-thick 1½" solid core high-performance particleboard; resists warping.
- Recessed modesty panel design facilitates conferencing. See approach side illustration at left.
- Full height modesty panels.
- Drawers operate on full extension, ball-bearing suspensions to ensure smooth, quiet, long-lasting operation.
- See page 137 for handle design/finish options.
- File drawer design includes integrated hangrails for side-to-side letter or legal filing; and front-to-back for letter filing.
- All drawers are 5-sided construction, which allows easy drawer alignment or replacement of drawer fronts.
- Valido® 18¾"D modular and mobile pedestals can be positioned under credenza with kneespace and single pedestal credenza models.
- Desk, credenza and return models ship assembled.
- For conference table options, see the Preside® table tops and bases on pages 774-779. Order edge option "K".
- See pages 150-166 for shared components.

HOW TO SPECIFY

Select Model Number H 1 1 5 9 0 5 R .	Select Edge Profile See page 137 A .	Select Handle Option See page 137 C .	Select Laminate See page 137 N N
---	---	--	---

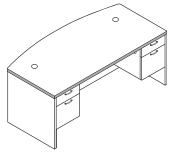
**DESCRIPTION****Double Pedestal Desk, 2-2**

72"W x 36"D x 29½"H, Bow Top	10½"	H11595	356	52.2	\$1959
72"W x 36"D x 29½"H, Rectangle Top	10½"	H11593	364	52.2	\$1795
66"W x 30"D x 29½"H, Rectangle Top	4½"	H11571	304	40.9	\$1712
60"W x 30"D x 29½"H, Rectangle Top	4½"	H11573	288	37.3	\$1615

NOTES: All drawers lock. Two worksurface grommets to route/hide cords. See page 161 for optional center drawers.

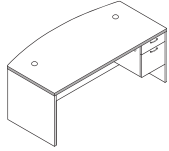
**Single Pedestal Desk, Bow Top**

72"W x 36"D x 29½"H, Right	10½"	H11587R	264	52.9	\$1727
72"W x 36"D x 29½"H, Left	10½"	H11588L	264	52.9	\$1727

NOTES: Drawers lock. Two worksurface grommets to route/hide cords. See page 161 for optional center drawers. Bow top models measure 36"D at the crest and 30"D along the end panels.

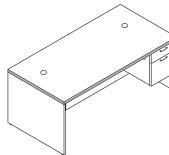
**Single Pedestal Desk, Rectangle Top**

72"W x 36"D x 29½"H, Right	10½"	H11585R	303	52.2	\$1525
66"W x 30"D x 29½"H, Right	4½"	H11583R	247	40.9	\$1426
72"W x 36"D x 29½"H, Left	10½"	H11586L	303	52.2	\$1525
66"W x 30"D x 29½"H, Left	4½"	H11584L	247	40.9	\$1426

NOTES: Drawers lock. Two worksurface grommets to route/hide cords. See page 161 for optional center drawers.

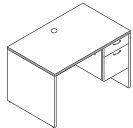
**Small Office Desk**

48"W x 30"D x 29½"H	4½"	H11585R	183	30.0	\$1150
---------------------	-----	----------------	-----	------	---------------

NOTES: Small footprint makes this desk ideal for limited space. Drawers lock. One cord grommet in top for routing and hiding wires and cables. 3/4 length modesty panel facilitates reaching wall electrical outlets. Optional stack-on storage model H115323 maximizes storage space; see pages 153-154 for additional stack-on storage models.

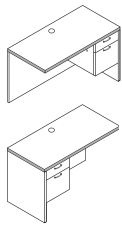
**Return, Box/File**

48"W x 24"D x 29½"H, Right	H11515R	158	24.9	\$1110
42"W x 24"D x 29½"H, Right	H11511R	146	20.5	\$1097
48"W x 24"D x 29½"H, Left	H11516L	158	24.9	\$1110
42"W x 24"D x 29½"H, Left	H11512L	146	20.5	\$1097

NOTES: Return is for use with single pedestal desks, desk shells, peninsulas or corner units. Drawers lock. One worksurface grommet and one cord pass-through grommet in top center of modesty panel to reach wall electrical outlets. See pages 153-154 for optional stack-on storage.

❗ Not designed to be used freestanding.

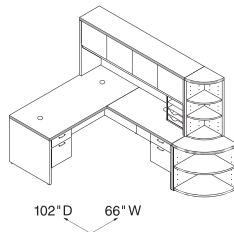

H11584L
H11515R
H115327
H115520
H115523
HLVPM1

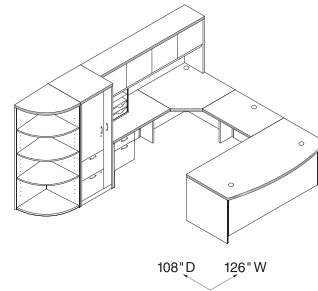

H11587R
H115598
H115811
H11516L
H115301
H115524
H115327
HLVPM1

NOTES:

- For components that can be shared with Valido/11500 Series, see pages 150-166.
- Tops are abrasion- and stain-resistant laminate over extra-thick 1½" solid core high-performance particleboard; resists warping.
- 3/4 pedestal design increases budget flexibility.
- Formal, full height modesty panels.
- 3" round worksurface grommet can be replaced with optional Power Hub (model HGRMTAC) or Power/USB Hub (model HGRMTUSB2) to bring the ease of plug-and-play to the desktop. See page 165.
- All drawers are 5-sided construction, which allows easy drawer alignment or replacement of drawer fronts.
- The small footprint of the Small Office Desk is ideal for limited space.
- Drawers operate on full extension, ball-bearing suspensions to ensure smooth, quiet, long-lasting operation.
- See page 137 for handle design/finish options.
- Center drawers conveniently store writing instruments, paper and other miscellaneous items. Includes pencil tray. See page 161.
- File drawer design includes integrated hangrails for side-to-side letter or legal filing; and front-to-back for letter filing.
- Desk, credenza and return models ship assembled.
- See pages 153-154 for optional stack-on storage.
- For conference table options, see the Preside® table tops and bases on pages 774-779. Order edge option "K".

HOW TO SPECIFY

Select Model Number	Select Edge Profile	Select Handle Option	Select Laminate
See page 137	See page 137	See page 137	See page 137
H 1 1 5 9 5	A	C	NN

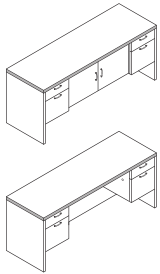

DESCRIPTION

Credenza with Doors
72"W x 24"D x 29½"H

FULL WIDTH OVERHANG **MODEL** **SHIP WEIGHT** **CUBE** **LIST PRICE**

3½" **H11544** 294 36.0 **\$1975**

NOTES: Includes one fixed shelf at the bottom of the center storage area. All drawers lock. Doors are non-locking.

Credenza with Kneespace

72"W x 24"D x 29½"H
66"W x 24"D x 29½"H
60"W x 24"D x 29½"H

3½" **H11543** 259 36.0 **\$1663**
3½" **H11566** 249 31.6 **\$1615**
3½" **H11565** 239 28.8 **\$1556**

NOTES: One cord pass-through grommet in top center of modesty panel to reach wall electrical outlets. All drawers lock. See pages 153-154 for optional stack-on storage.

⚠ Not designed to be used with Valido/11500 Series 22¾"D modular or mobile pedestals. Modesty/back panel is inset 3½".

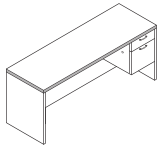

Credenza, Single Pedestal, Box/File

72"W x 24"D x 29½"H, Right (shown)
72"W x 24"D x 29½"H, Left

3½" **H11545R** 228 36.0 **\$1394**
3½" **H11546L** 228 36.0 **\$1394**

NOTES: One cord pass-through grommet in top center of modesty panel to reach wall electrical outlets. Drawers lock. See pages 153-154 for optional stack-on storage.

⚠ Not designed to be used with Valido/11500 Series 22¾"D modular or mobile pedestals. Modesty/back panel is inset 3½".

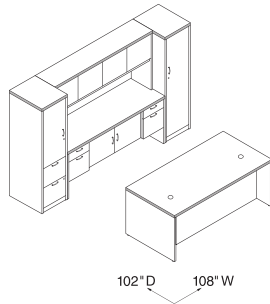

H11593
H11544
H115295R
H115298L
H11534

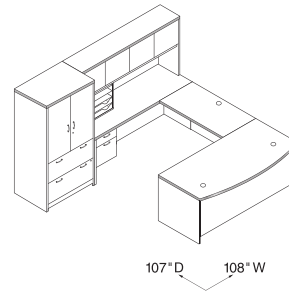

H11587R
H11570
H11546L
H11534
H115293
HLVPM1

NOTES:

- For components that can be shared with Valido/11500 Series, see pages 150-166.
- Tops are abrasion- and stain-resistant laminate over extra-thick 1½" solid core high-performance particleboard; resists warping.
- Formal, full height modesty panels.
- Cord management grommets, for routing and hiding wires and cables, are located in the tops of desks, returns, bridges and corner units.
- All drawers are 5-sided construction, which allows easy drawer alignment or replacement of drawer fronts.
- Drawers operate on full extension, ball-bearing suspensions to ensure smooth, quiet, long-lasting operation.
- See page 137 for handle design/finish options.
- File drawer design includes integrated hangrails for side-to-side letter or legal filing; and front-to-back for letter filing.
- For conference table options, see the Preside® table tops and bases on pages 774-779. Order edge option "K".

HOW TO SPECIFY

<p>Select Model Number</p> <p>H 1 1 5 4 4 .</p>	<p>Select Edge Profile</p> <p>See page 137</p> <p>A .</p>	<p>Select Handle Option</p> <p>See page 137</p> <p>C .</p>	<p>Select Laminate</p> <p>See page 137</p> <p>N N</p>
--	--	---	--

VALIDO®

Shared Components & Accessories

GSA SIN 33721

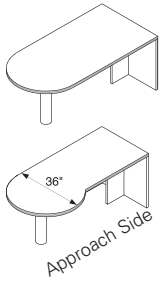

Icon Legend on page 19

**DESCRIPTION****Peninsula w/End Panel**

72"W x 36"D x 29½"H
66"W x 30"D x 29½"H
60"W x 30"D x 29½"H

MODEL

H11521
H11522
H11523

SHIP WEIGHT

171
142
119

CUBE

15.1
11.8
11.4

LIST PRICE

\$1082
\$988
\$918

P-shaped Peninsula w/End Panel

72"W x 30/36"D x 29½"H, Right (shown)
72"W x 36/30"D x 29½"H, Left

H11525R
H11526L

163
163

13.4
13.4

\$1203
\$1203

NOTES: Use for "U" or "L" configuration. 60"W ideal for smaller spaces. Cord routing notch in brace panel. Accept field installable modesty panel model H10528 (see page 151). See page 161 for optional center drawers. Peninsulas ship complete with end panel and support column. Support column is black.

❗ Not designed to be used freestanding.

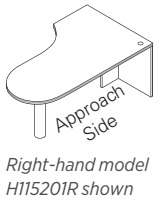
**Jetty Peninsula w/End Panel**

72"W x 30/42"D x 29½"H, Right (shown)
72"W x 42/30"D x 29½"H, Left

H115201R
H115202L

179
179

16.9
16.9

\$1394
\$1394

NOTES: For use in "U" or "L" configuration. Designed and sized to efficiently serve as both a computing and conferencing space. One cord management grommet in the top; cord routing notch in brace panel. Jetty units manufactured on or after 10/24/2005 accept field installable modesty panel H10528 (see page 151). Peninsulas ship complete with end panel and support column. Support column is black.

❗ Not designed to be used freestanding.

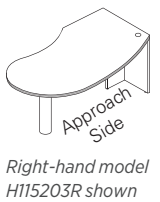
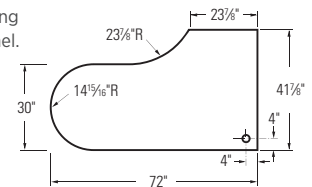
**Boomerang Peninsula w/End Panel**

72"W x 30/42"D x 29½"H, Right (shown)
72"W x 42/30"D x 29½"H, Left

H115203R
H115204L

176
176

16.9
16.9

\$1394
\$1394

NOTES: For use in "U" or "L" configuration. Designed and sized to efficiently serve as both a computing and conferencing space. One cord management grommet in the top; cord routing notch in brace panel. Accepts field installable modesty panel H10528 (see page 151). Peninsulas ship complete with end panel and support column. Support column is black.

❗ Not designed to be used freestanding.

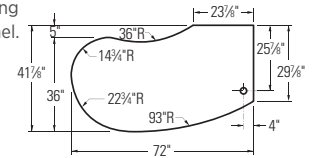
**NOTES:**

- Shared components shown on this page can be used with modular components shown on pages 141-145, full pedestal models shown on pages 146-147, and 3/4 pedestal models shown on pages 148-149.
- Mobile pedestals shown on page 157 work well in a variety of configurations.
- Peninsulas ship complete with end panel and black 4½" diameter support column. For a silver support column option, please see model HPC191X on page 251 (ordered separately).
- Jetty, Boomerang and Rudder peninsulas are designed and sized to efficiently serve as both a computing and conferencing space.
- Adjustable hex leveling glides allow floor-standing furniture to be easily leveled; glides have ¾" adjustable range.
- For conference table options, see the Preside® table tops and bases on pages 774-779. Order edge option "K".
- See pages 150-166 for shared components.

HOW TO SPECIFY**Select Model Number**

H 1 1 5 2 1 .

Select Edge Profile

See page 137



A .

Select Laminate

See page 137

N N



	DESCRIPTION	MODEL	SHIP WEIGHT	CUBE	LIST PRICE
	Field Installable Modesty Panel for Peninsulas 50 1/4"W x 3/4"Thick x 18"H NOTES: Center drawer model H1522 can be used in conjunction with modesty panel. Laminate Modesty Panel has a cord pass-through notch in top corner. ⓘ Not designed to be used on jetty peninsulas manufactured prior to 10/24/2005. SPECIFYING EXAMPLE: H10528.N	H10528	25	1.3	\$188
	Field Installable Modesty Panel for Bullet, Jetty and Boomerang Peninsulas, Frosted with Silver Frame 50 1/4"W x 3/4"Thick x 18"H NOTES: For use on 72"W peninsulas. Frosted/silver modesty panel HPC180G can be used with Valido, 10700, 10600 and 10500 Series™ peninsula models. Cord pass-through notch is not available on the Frosted/Silver model HPC180G. Notch is on laminate model H10528 only. ⓘ Center drawers not designed to be used with the frosted/silver modesty panel model HPC180G.	HPC180G	33 ⓘ	1.5	\$694

NOTES:

- Shared components shown on this page can be used with modular components shown on pages 141-145, full pedestal models shown on pages 146-147, and 3/4 pedestal models shown on pages 148-149.
- Mobile pedestals shown on page 157 work well in a variety of configurations.
- Peninsulas ship complete with end panel and black 4 1/2" diameter support column. For a silver support column option, please see model HPC191X on page 251 (ordered separately).
- Jetty, Boomerang and Rudder peninsulas are designed and sized to efficiently serve as both a computing and conferencing space.
- Adjustable hex leveling glides allow floor-standing furniture to be easily leveled; glides have 3/4" adjustable range.
- For conference table options, see the Preside® table tops and bases on pages 774-779. Order edge option "K".
- See pages 150-166 for shared components.

HOW TO SPECIFY

<p>Select Model Number</p> <p>H 1 0 5 2 8 . N N</p>	<p>Select Laminate</p> <p>See page 137</p>
--	---

VALIDO®

Shared Components & Accessories

GSA SIN 33721



Icon Legend on page 19

**DESCRIPTION****MODEL****SHIP WEIGHT****CUBE****LIST PRICE****Bridge (Single Ped. Desk, Desk Shell or Peninsula, to Corner Unit, Single Ped. Credenza or Credenza Shell)**

47"W x 24"D x 29½"H, (Clear inside depth = 21⅞"D)

H11570

86

3.2

\$505

42"W x 24"D x 29½"H, (Clear inside depth = 21⅞"D)

H11560

81

2.9

\$483

36"W x 24"D x 29½"H, (Clear inside depth = 21⅞"D) (see notes below)

H115599

69

2.9

\$483

30"W x 24"D x 29½"H, (Clear inside depth = 21⅞"D) (see notes below)

H115598

57

2.2

\$483

47"W x 20"D x 29½"H, (Clear inside depth = 17⅞"D) (see notes below)

H115699

70

3.2

\$483

42"W x 20"D x 29½"H, (Clear inside depth = 17⅞"D) (see notes below)

H115698

62

2.9

\$462

NOTES: One worksurface grommet and one grommet in top and in top center of modesty panel. Grommet can be replaced with optional Power Hub or Power/USB Hub for easy plug-and-play (see page 165). Kneespace of desk limited to 24¾"W if bridge is used with 66"W single pedestal desk. H115599 is for use with corner or extended corner units or jetty or boomerang peninsulas. H115598 is for use with corner or extended corner units. H115699 and H115698 are for use with single pedestal desks, desk shells or peninsulas (excluding jetty and boomerang).

Specify: Model.Edge.Laminate

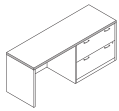
SPECIFYING EXAMPLE: H11570.A.NN**Credenza with 36" Lateral (with core removable locks)**

72"W x 24"D x 29½"H, Right (shown)

H11547R

264

36.0

\$1784

72"W x 24"D x 29½"H, Left

H11548L

264

36.0

\$1784

NOTES: Includes hangrails. Mechanical interlock inhibits the extension of more than one drawer at a time. See pages 153-154 for optional stack-on storage.

⚠ Not designed to be used with Valido/11500 Series 22¾"D modular or mobile pedestals. Modesty/back panel is inset 3½".

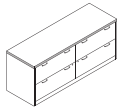
**Credenza with two Lateral Files (with core removable locks)**

72"W x 24"D x 29½"H

H115491

330

36.0

\$2500

NOTES: 4 locking drawers. Each lock secures 2 drawers. Includes hangrails; mechanical interlock inhibits the extension of more than one drawer at a time. If side-by-side drawers are opened or closed simultaneously, one drawer may interfere with the other. See pages 153-154 for optional stack-on storage.

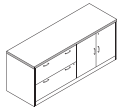
**Credenza with Lateral File, left and Storage Cabinet, right (with core removable locks)**

72"W x 24"D x 29½"H

H115492

323

36.0

\$2268

NOTES: Includes hangrails; mechanical interlock inhibits the extension of more than one drawer at a time. Storage cabinet locks and includes one adjustable interior shelf. Shelf adjusts in 1¼" increments with a total range of 5"H. See pages 153-154 for optional stack-on storage.

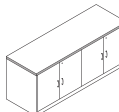
**Credenza w/Two Storage Cabinets**

72"W x 24"D x 29½"H

H115493

320

35.6

\$2013

NOTES: Each storage cabinet has one interior shelf which adjusts in 1¼" increments over a total range of 5". Each cabinet locks independently. Locks are keyed alike. For optional stack-on storage, see pages 153-154 for additional stack-on storage models.

NOTES:

- Shared components shown on this page can be used with modular components shown on pages 141-145, full pedestal models shown on pages 146-147, and 3/4 pedestal models shown on pages 148-149.
- Mobile pedestals shown on page 157 work well in a variety of configurations.
- Locking units equipped with interchangeable core removable locks.
- File drawers accept hanging folders in letter or legal size.
- See page 137 for handle design/finish options.
- Adjustable hex leveling glides allow floor-standing furniture to be easily leveled; glides have ¾" adjustable range.
- See pages 150-166 for shared components.

⚠ Keyed alike cores must be ordered separately — see page 853.

HOW TO SPECIFY**Select Model Number**

H 1 1 5 4 7 R .

Select Edge Profile

See page 137

A .

Select Handle Option

See page 137

Not specified on Bridge models

C .

Select Laminate

See page 137

N N

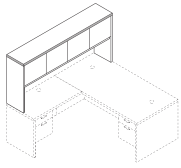
**DESCRIPTION**

Stack-on Storage for an "L" Workstation
78"W x 14⁵/₈"D x 37¹/₂"H

MODEL SHIP WEIGHT CUBE LIST PRICE

H115327 209 17.6 **\$1437**

Stack-on Storage for an "L" Workstation, Locking
78"W x 14⁵/₈"D x 37¹/₂"H

H115327K 209 17.6 **\$1520**

NOTES: Spans the total depth dimension of configurations comprised of: 48"W return or return shell attached to a 30"D single pedestal desk, desk shell or peninsula (78"D); 42"W return or return shell attached to a 36"D single pedestal desk, desk shell or peninsula (78"D). 42"W return or return shell attached to a 36" corner unit (78"D); or 42"W curved return attached to 36" curved corner unit (78"D). Use back enclosure model H105857 and model H90057 (see page 155). Use task light models HH870960, or HH870960CH (see page 545). For vertical paper manager model HLVP1, see page 162.

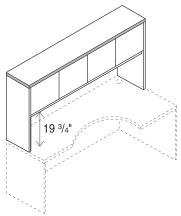
**Stack-on Storage (See page 155 for Back Enclosures and Fabric)**

72"W x 14⁵/₈"D x 37¹/₂"H, 4 doors (Use Task Light model HH870960, see page 164) **H11534** 66" 195 16.9 **\$1291**
 W x 14⁵/₈"D x 37¹/₂"H, 4 doors (Use Task Light model HH870960, see page 164) **H11533** 60" 184 15.3 **\$1261**
 W x 14⁵/₈"D x 37¹/₂"H, 4 doors (Use Task Light model HH870960, see page 164) **H115324** 48" 172 14.0 **\$1207**
 W x 14⁵/₈"D x 37¹/₂"H, 3 doors (Use Task Light model HH870942, see page 164) **H115323** 42" 148 11.3 **\$1049**
 W x 14⁵/₈"D x 37¹/₂"H, 2 doors (Use Task Light model HH870942, see page 164) **H115322** 36" 141 4.0 **\$903**
 W x 14⁵/₈"D x 37¹/₂"H, 2 doors (Use Task Light model HH870930, see page 164) **H115321** 107 3.5 **\$865**

Stack-on Storage, Locking (See page 155 for Back Enclosures and Fabric)

72"W x 14⁵/₈"D x 37¹/₂"H, 4 doors (Use Task Light model HH870960, see page 164) **H11534K** 195 16.9 **\$1375**
 66"W x 14⁵/₈"D x 37¹/₂"H, 4 doors (Use Task Light model HH870960, see page 164) **H11533K** 184 15.3 **\$1344**
 60"W x 14⁵/₈"D x 37¹/₂"H, 4 doors (Use Task Light model HH870960, see page 164) **H115324K** 172 14.0 **\$1290**
 48"W x 14⁵/₈"D x 37¹/₂"H, 3 doors (Use Task Light model HH870942, see page 164) **H115323K** 148 11.3 **\$1091**
 42"W x 14⁵/₈"D x 37¹/₂"H, 2 doors (Use Task Light model HH870942, see page 164) **H115322K** 141 4.0 **\$945**
 36"W x 14⁵/₈"D x 37¹/₂"H, 2 doors (Use Task Light model HH870930, see page 164) **H115321K** 107 3.5 **\$906**

NOTES: Models H11534 and H11534K can be used for "L" configuration comprised of 30"D desk, desk shell or peninsula and 42"W return or return shell. Model H115323K has one lock which secures two of the three doors. For vertical paper manager, see page 162.

NOTES:

- Shared components shown on this page can be used with modular components shown on pages 141-145, full pedestal models shown on pages 146-147, and 3/4 pedestal models shown on pages 148-149.
- Stack-on storage models are equipped with self-closing, adjustable hinged doors and valance to hide task light.
- For work-in-process paper management tools, see page 162.
- See pages 150-166 for shared components.

❗ Removable lock core kit for stack-on and wall mount storage is model HF27B, see page 853.

❗ The HON Company is not responsible for any liabilities resulting from wall mounted storage cabinets that are not properly installed.

HOW TO SPECIFY

Select Model Number H 1 1 5 3 4	Select Edge Profile See page 137 A	Select Laminate See page 137 N N
---	---	---

VALIDO® Shared Components & Accessories

GSA SIN 33721

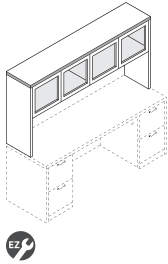

Icon Legend on page 19

**DESCRIPTION****MODEL SHIP WEIGHT CUBE LIST PRICE****Stack-on Storage for an "L" Workstation, Frosted Doors with Silver Frame**78"W x 14⁵/₈"D x 37¹/₂"H, 4 doors (Use Task Light model HH870960, see page 164)**H115327G** 210 18.4 **\$2063**

NOTES: Spans the total depth dimension of configurations comprised of: 48"W return or return shell attached to a 30"D single pedestal desk, desk shell or peninsula (78"D); 42"W return or return shell attached to a 36"D single pedestal desk or desk shell with a rectangle top, or to a peninsula (78"D); 42"W return or return shell attached to a 36" corner unit (78"D); 42"W curved return attached to 36" curved corner unit (78"D); or 36"W return shell attached to a jetty peninsula (78"D). Use back enclosure model H105857 and model H90057. Use task light models HH870960 or HH870960CH. For vertical paper manager model HLVPM1, see page 162.

Stack-on Storage, w/Frosted Doors with Silver Frame72"W x 14⁵/₈"D x 37¹/₂"H, 4 doors (Use Task Light model HH870960, see page 164)**H11534G** 196 17.0 **\$1917**66"W x 14⁵/₈"D x 37¹/₂"H, 4 doors (Use Task Light model HH870960, see page 164)**H11533G** 185 15.6 **\$1886**60"W x 14⁵/₈"D x 37¹/₂"H, 4 doors (Use Task Light model HH870960, see page 164)**H115324G** 173 14.2 **\$1832**48"W x 14⁵/₈"D x 37¹/₂"H, 3 doors (Use Task Light model HH870942, see page 164)**H115323G** 148 11.5 **\$1518**42"W x 14⁵/₈"D x 37¹/₂"H, 2 doors (Use Task Light model HH870942, see page 164)**H115322G** 141 4.1 **\$1216**36"W x 14⁵/₈"D x 37¹/₂"H, 2 doors (Use Task Light model HH870930, see page 164)**H115321G** 107 4.1 **\$1177**

NOTES: For respective desk, credenza or return widths. Model 11534 can be used for "L" configuration comprised of a 42"W return or return shell attached to a 30"D single pedestal desk, desk shell or peninsula (72"); 36"W return shell attached to a 36"D single pedestal desk, desk shell or peninsula (72"); or 30"W return shell attached to a jetty peninsula (72"). Back enclosures, for use with back enclosures and task lights are available as options. See vertical paper manager model HLVPM1 on page 162.

Stack-on Storage models H115327G, H11534G, H11533G and H115324G use task light model HH870960. Models H115323G and H115322G use task light model HH870942 and model H115321G uses task light model HH870930. All task lights can be found on page 164.

Stack-on Storage Clearance End Panel Kit1¹/₈"W x 4⁵/₈"-14⁵/₈"D x 36"H**H105349** 29 3.4 **\$360**

Two field installable end panels (1-right; 1-left) for use in ganging two 10500 or Valido® Series stack-on storage units. See page 269.

NOTES: Can be used to connect up to two stack-on storage units in a line (requires 1 kit). Not available in two-tone laminate.

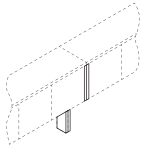
SPECIFYING EXAMPLE: H105349.N**NOTES:**

- Shared components shown on this page can be used with modular components shown on pages 141-145, full pedestal models shown on pages 146-147, and 3/4 pedestal models shown on pages 148-149.
- Stack-on storage models are equipped with self-closing, adjustable hinged doors and valance to hide task light.
- For work-in-process paper management tools, see page 162.
- See pages 150-166 for shared components.

! Removable lock core kit for stack-on and wall mount storage is model HF27B, see page 853.

! The HON Company is not responsible for any liabilities resulting from wall mounted storage cabinets that are not properly installed.

HOW TO SPECIFY**Select
Model Number**

H 1 1 5 3 2 7 G .

**Select
Edge Profile**

See page 137

A .

**Select
Laminate**

See page 137

N N



Icon Legend on page 19

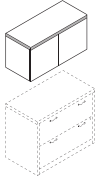

DESCRIPTION

Wall Mounted Storage Cabinet

30"W x 14 5/8"D x 17 7/8"H, 2 doors
(Use Task Light model HH870930, see page 164)
36"W x 14 5/8"D x 17 7/8"H, 2 doors
(Use Task Light model HH870930, see page 164)
42"W x 14 5/8"D x 17 7/8"H, 2 doors
(Use Task Light model HH870942, see page 164)
48"W x 14 5/8"D x 17 7/8"H, 3 doors
(Use Task Light model HH870942, see page 164)

MODEL	COM	SHIP WEIGHT	CUBE	LIST PRICE
H115380		77	8.7	\$872
H115381		92	10.2	\$918
H115382		103	11.7	\$988
H115383		121	14.0	\$1067

Wall Mounted Storage Cabinet, Locking

30"W x 14 5/8"D x 17 7/8"H, 2 doors
(Use Task Light model HH870930, see page 164)
36"W x 14 5/8"D x 17 7/8"H, 2 doors
(Use Task Light Model HH870930, see page 164)
42"W x 14 5/8"D x 17 7/8"H, 2 doors
(Use Task Light Model HH870942, see page 164)
48"W x 14 5/8"D x 17 7/8"H, 3 doors
(Use Task Light Model HH870942, see page 164)

H115380K		77	8.7	\$914
H115381K		92	10.2	\$960
H115382K		103	11.7	\$1029
H115383K		121	14.0	\$1109

NOTES: Horizontal interlocking rails are included; due to varying types of walls, installers are responsible for selecting and supplying the appropriate fasteners. widths differ slightly from wall mounted storage cabinet widths. For applications where multiple wall mounted storage cabinets are placed side-by-side, the preferred solution may be to utilize a larger size. For example, H90057 = 75"W; H90056 = 68 3/4"W; H90055 = 62 3/4"W; H90054 = 56 3/4"W. For paper organizer tools, see page 162.

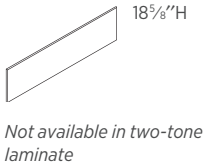

Back Enclosure for Stack-on Storage

75 3/4"W - for 78"W model #H115327
69 3/4"W - for 72"W model #H11534
63 3/4"W - for 66"W model #H11533
57 3/4"W - for 60"W model #H115324
45 3/4"W - for 48"W model #H115323
39 3/4"W - for 42"W model #H115322
33 3/4"W - for 36"W model #H115321

H105857		39	1.4	\$259
H105856		33	1.3	\$237
H105855		31	1.3	\$221
H105854		29	1.3	\$211
H105853		23	0.9	\$211
H105852		21	0.9	\$201
H105851		18	0.9	\$190

NOTES: Non-tackable. Specify laminate.

SPECIFYING EXAMPLE: H105857.N

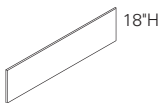

for use with Stack-on Back Enclosures

75"W - for 78"W model #H115327 Hutch with #H105857 Enclosure
68 3/4"W - for 72"W model #H11534 Hutch with #H105856 Enclosure
62 3/4"W - for 66"W model #H11533 Hutch with #H105855 Enclosure
56 3/4"W - for 60"W model #H115324 Hutch with #H105854 Enclosure
44 3/4"W - for 48"W model #H115323 Hutch with #H105853 Enclosure
39"W - for 42"W model #H115322 Hutch with #H105852 Enclosure
33"W - for 36"W model #H115321 Hutch with #H105851 Enclosure

H90057	3.0	13	3.2	\$317
H90056	2.0	12	2.7	\$301
H90055	2.0	11	2.5	\$286
H90054	2.0	10	2.2	\$252
H90053	2.0	8	1.8	\$242
H90052	2.0	7	1.6	\$223
H90051	1.0	6	1.4	\$196

NOTES: Specify fabric, see pages 25-26. Upcharges may apply to premium fabric grades.

ⓘ Disperse (DISP) fabric not available on sizes wider than 60". Analog (ANLG) and Exchange (EXG) not available on sizes wider than 72".

ⓘ Back Enclosures must be ordered separately.

SPECIFYING EXAMPLE: H90057.APN15

NOTES:

- Shared components shown on this page can be used with modular components shown on pages 141-145, full pedestal models shown on pages 146-147, and 3/4 pedestal models shown on pages 148-149.
- Back enclosure features full-width 1 1/8" slot at the bottom to facilitate routing cords and reaching wall electrical outlets.
- is sized 3/4" narrower than stack-on storage back enclosure, allowing 3/8" on each side to route task light cord.
- Wall mounted storage cabinet attachment requires individual cabinets be secured by a minimum of two wall mounting locations/studs.
- Wall mounted storage cabinets are designed for interior and perimeter walls that are constructed with wood or metal studs.
- Wall attachment methodology: horizontally mounted, interlocking brackets.
- Wall mounted storage cabinet door design overlaps end panels so that when multiple units are placed side-by-side they appear as one continuous unit.
- See pages 150-166 for shared components.

ⓘ Removable lock core kit for stack-on and wall mount storage is model HF27B, see page 853.

ⓘ The HON Company is not responsible for any liabilities resulting from wall mounted storage cabinets that are not properly installed.

HOW TO SPECIFY

<p>Select Model Number</p> <p>H 1 1 5 3 8 0 .</p>	<p>Select Edge Profile</p> <p>See page 137</p> <p>A .</p>	<p>Select Laminate</p> <p>See page 137</p> <p>NN</p>
--	--	---

VALIDO® Shared Components & Accessories

GSA SIN 33721



Icon Legend on page 19

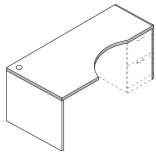

Right-hand model
H115815R shown

DESCRIPTION

Extended Corner Unit

24"W x 36"D x 72"W x 24"D x 29½"H, Right (shown)
24"D x 72"W x 36"D x 24"W x 29½"H, Left

NOTES: Can be used freestanding. One grommet in top and in modesty panel. Accept Valido/11500 Series modular or mobile pedestals. See pages 153-154 for optional stack-on storage.

ⓘ Designed to be used with returns or bridges.

SPECIFYING EXAMPLE: H115815R.A.NN

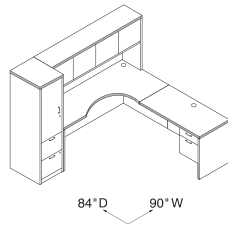
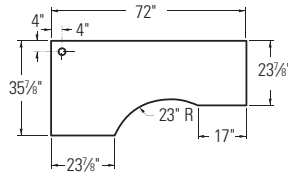

H115298L
H115816L
H11534
H11515R

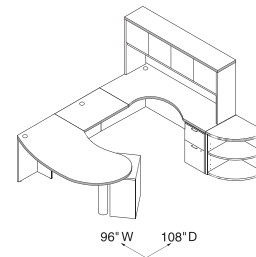

H115103
H115204L
H115598
H115815R
H115104
H11534
H115520

MODEL SHIP WEIGHT CUBE LIST PRICE

H115815R	203	7.0	\$1308
H115816L	203	7.0	\$1308

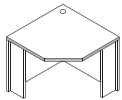

Corner Unit

24" x 36" x 36" x 24" x 29½"H

NOTES: Can be used freestanding.

ⓘ Designed to be used with 24"D x 29½"H returns or bridges.

SPECIFYING EXAMPLE: H115811.A.NN

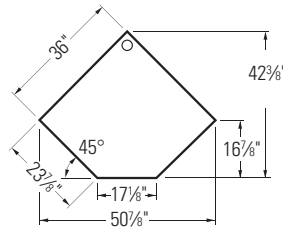

H115811	141	3.1	\$902
----------------	-----	-----	--------------











NOTES:

- Shared components shown on this page can be used with modular components shown on pages 141-145, full pedestal models shown on pages 146-147, and 3/4 pedestal models shown on pages 148-149.
- Mobile pedestals, shown on page 157, work well in a variety of configurations.
- Extended corner units (H115815R and H115816L) can be used with 36"W return shell (H115680) to achieve a 6' x 6' layout.
- 36" corner unit (H115811) can be used with two 36"W return shells (H115680) to achieve a 6' x 6' layout.
- For conference table options, see the Preside® table tops and bases on pages 774-779. Order edge option "K".
- For work-in-process paper management tools, see page 162.
- See pages 150-166 for shared components.

HOW TO SPECIFY

<p>Select Model Number</p> <p>H 1 1 5 8 1 7 R .</p>	<p>Select Edge Profile</p> <p>See page 137</p> <p>A .</p>	<p>Select Laminate</p> <p>See page 137</p> <p>NN</p>
--	--	---

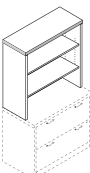

	DESCRIPTION	MODEL	SHIP WEIGHT	CUBE	LIST PRICE
	Mobile Pedestal (with core removable lock) — Box/Box/File 15 ³ / ₄ "W x 22 ³ / ₄ "D x 28 ³ / ₈ "H — use freestanding or under 24"D, 30"D and 36"D modular shells NOTES: Top box drawer does not lock.	H115102	121	8.4	\$939
	Mobile Pedestal (with core removable lock) — File/File 15 ³ / ₄ "W x 22 ³ / ₄ "D x 28 ³ / ₈ "H — use freestanding or under 24"D, 30"D and 36"D modular shells	H115104	121	8.4	\$939
	Mobile Pedestal (with core removable lock) — Box/File 15 ³ / ₄ "W x 18 ³ / ₄ "D x 21 ¹ / ₈ "H — use freestanding or under 20"D, 24"D, 30"D and 36"D modular shells	H115106	68	5.8	\$786
	Mobile Pedestal — Shelf/Box/File 15 ³ / ₄ "W x 18 ³ / ₄ "D x 28 ³ / ₈ "H — use freestanding or under 20"D, 24"D, 30"D and 36"D modular shells NOTES: All mobile pedestals have a 1 ¹ / ₈ " thick top with flat, non-profiled edge. SPECIFYING EXAMPLE: H115102.C.NN	H115109	76	7.3	\$863
	Lateral File (with core removable lock) 36"W x 24"D x 29 ¹ / ₂ "H — two drawer	H115690	199	18.4	\$1316
	36"W x 20"D x 29 ¹ / ₂ "H — two drawer	H11563	177	15.6	\$1253
	36"W x 20"D x 45 ¹ / ₂ "H — three drawer	H11517	247	23.2	\$1904
	36"W x 20"D x 59 ¹ / ₈ "H — four drawer NOTES: Includes hangrails, mechanical interlock, and in H11563 and H115690, a counterweight. Stack-on storage (H115321) and bookcase hutch (H115292) can be used with H11563 and H115690. Interlock inhibits the extension of more than one drawer from opening at a time. 24"D two-drawer model aligns with the depth of 24"D credenzas and returns. SPECIFYING EXAMPLE: H11563.A.C.NN	H11516	312	31.0	\$2654
	Storage Cabinet with Doors (with core removable lock) 36"W x 24"D x 29 ¹ / ₂ "H	H115290	176	18.4	\$1132
	36"W x 20"D x 29 ¹ / ₂ "H NOTES: Includes one adjustable shelf. Shelf adjusts in 1/4" increments with a total range of 5"H. Stack-on storage (H115321) and bookcase hutch (H115292) can be used with H115290 or H115291. 24"D model aligns with the depth of 24"D credenzas and returns. SPECIFYING EXAMPLE: H115291.A.C.NN	H115291	154	15.0	\$972
	Bookcase Hutch (for use with lateral file models H11563 or H115690 or storage cabinet with door models H115291 or H115290) 36"W x 14 ³ / ₈ "D x 37 ¹ / ₂ "H NOTES: Cord pass-through gap behind shelves and a 1 ¹ / ₈ "H full-width cord management slot at the bottom of the back panel to facilitate routing cords and reaching wall electrical outlets. When placed on top of 29 ¹ / ₂ "H base unit the total height (67"H) matches the height of credenzas with stack-on storage and the height of the wardrobe/storage cabinets and storage cabinet/lateral file. Two shelves are adjustable in 1/4" increments with a total range of 17 ¹ / ₂ "H. SPECIFYING EXAMPLE: H115292.A.NN	H115292	108	3.8	\$758

NOTES:

- For additional components that can be shared with Valido/11500 Series, see pages 150-166.
- Drawers operate on full extension, ball-bearing suspensions to ensure smooth, quiet, long-lasting operation.
- Versatile mobile pedestals work well in a variety of configurations. Can be used freestanding or under modular shells. 1¹/₈" thick top with a square, non-profiled edge.
- 24"D two drawer lateral file and 24"D storage cabinet with door models align with 24"D credenzas and returns, credenza and return shells as well as wardrobe/storage cabinets to provide linear layout continuity.
- Mobile printer/fax cart shown on page 145 is ideal for limited space.
- File drawer design includes integrated hangrails for side-to-side letter or legal filing; and front-to-back for letter filing.
- Adjustable hex leveling glides allow floor-standing furniture to be easily leveled; glides have 3/4" adjustable range.
- For conference table options, see the Preside® table tops and bases on pages 774-779. Order edge option "K".

HOW TO SPECIFY

Select Model Number See page 137 Not specified for models H115102, H115103 and H115104 H 1 1 5 6 3	Select Edge Profile See page 137 Not specified for models H115102, H115103 and H115104 A	Select Handle Option See page 137 Not specified for models H115292, H115520, H115523 and H115524 C	Select Laminate See page 137 NN
---	---	---	---

VALIDO®

Shared Components & Accessories

GSA SIN 33721



Icon Legend on page 19

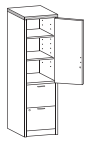

Right-hand model
H115297R shown

DESCRIPTION**Storage/File Cabinet (with core removable locks)**

18"W x 24"D x 67"H, Hinged Right (shown)
18"W x 24"D x 67"H, Hinged Left

MODEL

H115297R
H115298L

SHIP WEIGHT

262
262

CUBE

22.7
22.7

LIST PRICE

\$2055
\$2055

NOTES: Versatile unit features a storage cabinet and two file drawers. Storage cabinet includes three shelves, two are adjustable in 2½" increments. Door hinged left or right models available. File drawers operate on ball-bearing suspensions with full extension. File drawers have high sides to accept hanging folders in letter or legal size. Drawers standard with hangrails. Both the storage cabinet and the file drawers are equipped with an interchangeable core removable lock. Unit height is designed to match credenza or return plus stack-on storage height.



Doors open 110 degrees from
closed position.

Storage Cabinet/Lateral File (with core removable lock)

36"W x 24"D x 67"H

H115293

373

41.0

\$2665

NOTES: Storage cabinet is standard with one fixed and two full-width adjustable shelves in top compartment; adjustable shelves can be removed. Overall storage compartment measures 31¼"W x 22"D x 36½"H and will accommodate supplies, books and binders, as well as business machines and electronic equipment. Cord pass-through gap behind shelves and grommet in back of cabinet to facilitate routing cords and reaching wall electrical outlets. Two drawer lateral file on bottom. Lateral file comes with mechanical interlock and hangrails. Cabinet and lateral file lock independently. Unit height is designed to match credenza or return plus stack-on storage height.



Doors open 110 degrees from
closed position.

Storage Cabinet w/Doors (with core removable lock)

36"W x 24"D x 67"H

H115299

349

41.0

\$2381

NOTES: Large capacity storage area includes five, full-width (side-to-side) shelves; three are adjustable in 2½" increments. Unit height matches credenza or return plus stack-on storage height.

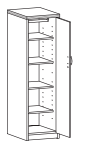

Right-hand model
H115295R shown

Personal Wardrobe/Storage Cabinet (with core removable lock)

18"W x 24"D x 67"H, Hinged Right (shown)
18"W x 24"D x 67"H, Hinged Left

H115295R
H115296L

227
227

22.9
22.9

\$1777
\$1777

NOTES: Unit is standard with four adjustable shelves, coat rod, and core removable lock. Shelves adjust in 2½" increments. Unit height is designed to match credenza or return plus stack-on storage height. Cabinet can be used as a wardrobe by removing four adjustable shelves. Coat rod can be removed from cabinet for storage only applications.

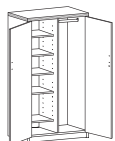

Doors open 110 degrees from
closed position.

Personal Wardrobe/Storage Cabinet (with core removable lock)

36"W x 24"D x 67"H

H11530

349

41.0

\$2603

NOTES: Spacious design is standard with four adjustable shelves (one shelf is fixed), coat rod and core removable lock which locks both doors. Shelves adjust in 2½" increments. Unit height is designed to match credenza or return plus stack-on storage height.

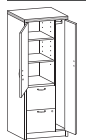

Right-hand model
H115301R shown

Personal Storage Tower (with core removable locks)

24"W x 24"D x 67"H, Wardrobe Hinged Right, Storage Cabinet Hinged
Left (shown)
24"W x 24"D x 67"H, Wardrobe Hinged Left, Storage Cabinet Hinged
Right

H115301R

304

27.9

\$2603**H115302L**

304

27.9

\$2603

NOTES: Spacious design includes a wardrobe closet, storage cabinet, and two file drawers in one compact unit. Wardrobe closet contains a coat rod. Storage cabinet includes three shelves, two are adjustable in 2½" increments. Door hinged left or right models available. File drawers operate on ball-bearing suspensions with full extension. File drawers have high sides to accept hanging folders in letter or legal size. Drawers standard with hangrails. Equipped with interchangeable core removable locks. Upper lock secures storage cabinet and wardrobe closet doors; lower lock secures file drawers. Unit height is designed to match credenza or return plus stack-on storage height.

NOTES:

- Adjustable hex leveling glides allow floor-standing furniture to be easily leveled; glides have ¾" adjustable range.
- Locking units equipped with interchangeable core removable locks.
- For conference table options, see the Preside® table tops and bases on pages 774-779. Order edge option "K".
- See pages 150-166 for shared components.

ⓘ Keyed alike cores must be ordered separately — see model HF23B on page 853.

HOW TO SPECIFY

Select Model Number	Select Edge Profile	Select Handle Option	Select Laminate
See page 137	See page 137	See page 137	See page 137
H 1 1 5 2 9 7 R .	A .	C .	NN

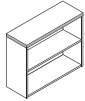

H11552 shown

DESCRIPTION**Bookcase**

36"W x 13¹/₈"D x 29⁵/₈"H, 2-Shelf
 36"W x 13¹/₈"D x 43³/₈"H, 3-Shelf
 36"W x 13¹/₈"D x 57¹/₈"H, 4-Shelf
 36"W x 13¹/₈"D x 71"H, 5-Shelf

MODEL**SHIP WEIGHT****CUBE****LIST PRICE****H11552**

94

10.2

\$651**H11553**

126

15.6

\$762**H11554**

160

20.3

\$907**H11555**

191

25.3

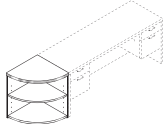
\$1023NOTES: Fixed shelves. Inside shelf dimensions on all units is 33³/₄"W x 12"D x 13"H. No assembly required.**SPECIFYING EXAMPLE: H11552.A.NN****End Cap Bookshelf**24"W x 24"D x 29¹/₂"H**H115520**

87

2.6

\$763(2 shelves, 1 fixed, 1 adjustable. Adjusts in 2¹/₂" increments with a total range of 10"H)

NOTES: Unit is freestanding. Designed to be positioned at the end of 24"D credenzas and returns. Holds books and personal items.

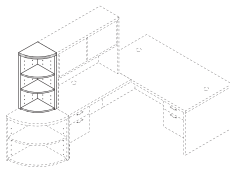
SPECIFYING EXAMPLE: H115520.A.NN**End Cap Bookshelf**15"W x 15"D x 37¹/₂"H**H115523**

54

2.2

\$675(3 shelves, 1 fixed, 2 adjustable. Adjusts in 2¹/₂" increments with a total range of 25"H)

NOTES: Unit is designed to be positioned at the end of stack-on storage and on top of model H115520. Combined height of models H115520 and H115523 matches credenza plus stack-on storage height. Can be used freestanding.

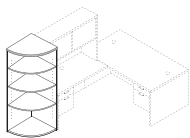
SPECIFYING EXAMPLE: H115523.A.NN**End Cap Bookshelf**

24"W x 24"D x 67"H

H115524

167

4.8

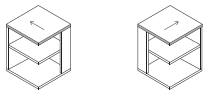
\$1213NOTES: Designed to be positioned at the end of 24"D credenzas with stack-on storage, 24"D returns with stack-on storage, 24"D storage/file cabinet, 24"D storage cabinet/lateral file, 24"D wardrobe/storage cabinets, or the 24"D personal storage tower. Unit has four shelves, three are adjustable in 2¹/₂" increments, with a total range of 45"H; bottom shelf is fixed.**SPECIFYING EXAMPLE: H115524.A.NN**

Model H115525R Model H115526L

Square End Cap Bookshelf — 2-Fixed Shelves24"W x 24"D x 29¹/₂"H, Right**H115525R**

98

3.7

\$75224"W x 24"D x 29¹/₂"H, Left**H115526L**

98

3.7

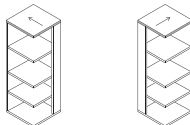
\$752**SPECIFYING EXAMPLE: H115525R.A.NN**

Model H115527R Model H115528L

Square End Cap Bookshelf — 4-Fixed Shelves

24"W x 24"D x 67"H, Right

H115527R

178

11.4

\$1161

24"W x 24"D x 67"H, Left

H115528L

178

11.4

\$1161**SPECIFYING EXAMPLE: H115527R.A.NN**

NOTES: Units are freestanding. Designed to be positioned next to 24"D models or as a corner bookcase.

End cap, left: grain direction on top aligns with grain direction on tops of left pedestal returns and left credenza models or when positioned to the left side of credenzas with doors or kneespace models.

End cap, right: grain direction on top aligns with grain direction on tops of right pedestal returns and right credenza models or when positioned to the right side of credenzas with doors or kneespace models.

NOTES:

- Choose from square or rounded versions of the end cap bookshelves.
- End cap bookshelf units are ideal for books, photos and mementos.
- End Cap Bookcases are designed to be positioned at the end of 24"D credenzas and returns.
- Adjustable hex leveling glides allow floor-standing furniture to be easily leveled; glides have ³/₄" adjustable range.
- End cap bookshelf units are ideal for books, photos and mementos.
- For conference table options, see the Preside® table tops and bases on pages 774-779. Order edge option "K".
- See pages 150-166 for shared components.

HOW TO SPECIFYSelect
Model Number

H 1 1 5 5 2 7 R .

Select
Edge Profile

See page 137

A .

Select
Laminate

See page 137

N N

VALIDO®

Shared Components & Accessories

GSA SIN 33721

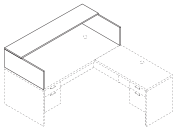
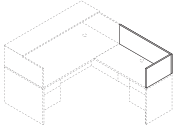
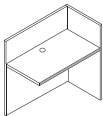
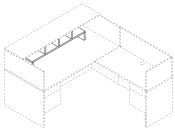

	DESCRIPTION	MODEL	SHIP WEIGHT	CUBE	LIST PRICE
	Reception Station with Transaction Counter for 72"W x 36"D Desk, or Desk Shell, with rectangle top 72"W x 36"D x 14 ⁵ / ₈ "H	H115720	100	3.0	\$725
	NOTES: For desk tops without grommets, see field installable grommet kit, model HFLDGRMT or HFLDGRMT3 on page 164. Transaction counter organizer (HTCOL52) fits under/inside of transaction counter (see below).				
	Reception Station for 42"W x 24"D Return or Return Shell 42"W x 24"D x 13"H	H105722	21	1.0	\$253
	Reception Station for 48"W x 24"D Return or Return Shell 48"W x 24"D x 13"H	H105721	25	3.6	\$288
	NOTES: For return tops without grommets, see field installable grommet kit, model HFLDGRMT or HFLDGRMT3 on page 164. ⓘ Not available in two tone laminate.				
	Reception Desk Shell 72"W x 39 ⁷ / ₈ "D x 44 ¹ / ₈ "H	H115724	328	16.8	\$1452
	NOTES: Non-handed design. Integrated 18 ⁵ / ₈ "D transaction counter with a 4" full-width overhang. Two cord management grommets in top for routing and hiding wires and cables. Transaction counter organizer (HTCOL52) fits under/inside of transaction counter.				
	Reception Return Shell 42"W x 24"D x 43 ⁵ / ₈ "H	H115726	140	16.8	\$943
	NOTES: Non-handed design. Attaches to reception desk shell to form an L-shaped workstation. One cord management grommet in top for routing and hiding wires and cables. Woodgrain on approach side is vertical to match grain direction on end panels of reception desk.				
	Transaction Counter Organizer 48 ³ / ₄ "W x 11 ¹ / ₈ "D x 13"H	HTCOL52	24	1.1	\$283
	NOTES: Fits under reception station with transaction counter model H115720 or reception desk shell H115724. ⓘ Black only.				

NOTES:

- Two welcoming reception station designs to choose from — stack-on enclosure or full-to-floor shell.
- See pages 150-166 for shared components.

HOW TO SPECIFY

Select Model Number H 1 1 5 7 2 4	Select Edge Profile See page 137 A	Select Laminate See page 137 N N
---	---	---



Icon Legend on page 19

Shared Components & Accessories

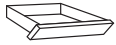

Refer to page 106 for Center Drawer compatibility information



DESCRIPTION	MODEL	SHIP WEIGHT	CUBE	LIST PRICE
Angled Wood Center Drawer 26" x 15 ³ / ₈ "	H1526	12.0 Ⓔ	1.2	\$198
22" x 15 ³ / ₈ "	H1522	11.0 Ⓔ	1.1	\$184

NOTES: Specify laminate for drawer. For additional information see page 832.

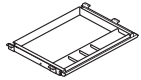

OPEN MARKET

Polymer Center Drawer • Color: Black. • Material: ABS. • Opening Requirements: 23"W x 16 ¹ / ₄ "D x 2"H. • Retracts on 16" ball-bearing slides. • Can be used on worksurfaces with Coordinate™ Height Adjustable Bases as long as it is attached with spacer model HKBS. • Can store up to 25 lbs.	HCD1	7.0	0.5	\$108
---	-------------	-----	-----	--------------

NOTES: For additional information see page 833.

! Black finish only, no specification needed.

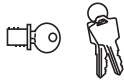

Black Removable Lock Core Kit — see page 853.	HF23B	0.1 Ⓔ	0.1	\$32
--	--------------	--------------	-----	-------------

NOTES: Lock with a removable cylinder that can be interchanged as needed; allows users to access all furniture pieces in an office with a single key for convenience and security.

Makes re-keying quick and easy. For use in all Valido® Series product lock cores, except the stack-on and wall mounted storage "K" models. For the latter, use lock core kit model HF27B.

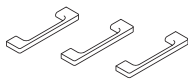
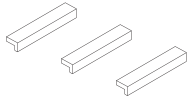

DESCRIPTION	MODEL	SHIP WEIGHT	CUBE	LIST PRICE
Field Installable Drawer/Door Handle Kits (fit Valido® 96mm hole spacing) Linear, Black, 2-pack	HLINEARA2	0.4 Ⓔ	0.3	\$56
Linear, Matte Chrome, 2-pack	HLINEARC2	0.4 Ⓔ	0.3	\$56
Linear, Black, 3-pack	HLINEARA3	0.5 Ⓔ	0.3	\$64
Linear, Matte Chrome, 3-pack	HLINEARC3	0.5 Ⓔ	0.3	\$64
Arch, Black, 2-pack	HARCHA2	0.4 Ⓔ	0.3	\$56
Arch, Matte Chrome, 2-pack	HARCHC2	0.4 Ⓔ	0.3	\$56
Arch, Black, 3-pack	HARCHA3	0.5 Ⓔ	0.3	\$64
Arch, Matte Chrome, 3-pack	HARCHC3	0.5 Ⓔ	0.3	\$64

NOTES: The Linear and Arch handles attach using the same 96mm hole spacing as the Valido® Sweep and Crescent handles. The Linear handle is not recommended for use on the Valido® Narrow/Box/Box/File Modular Pedestal — model H115093.

! Must be ordered with a configurable end product. If ordered separately, not on GSA contract.

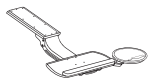

Refer to pages 829-830 for additional product information



DESCRIPTION	MODEL	SHIP WEIGHT	CUBE	LIST PRICE BY PAINT GRADE	
				P1	P2
Sit to Stand Arm with Convertible Keyboard Platform	H2516 OPEN MARKET *	17 Ⓔ	1.6	\$618	
Articulating Arm with Convertible Keyboard Platform	H2107 OPEN MARKET *	16 Ⓔ	1.3	\$529	
Articulating Arm with Keyboard Platform	H1706 OPEN MARKET *	16 Ⓔ	1.4	\$493	
Slide-Away Keyboard Platform (Specify: Laminate)	H4022	10 Ⓔ	0.6	\$213	
Extended Tray Slide-Away Keyboard Platform (Specify: Laminate)	HE4022	12 Ⓔ	0.7	\$302	
Metal Keyboard and Mouse Tray (Specify paint)	H4028 OPEN MARKET	11 Ⓔ	1.5	\$153	\$163
Metal Keyboard Tray (Specify paint)	H4029 OPEN MARKET	11 Ⓔ	1.5	\$138	\$148

NOTES: For additional information see pages 829-830.

NOTES:

- Linear and Arch field installable handles attach using Valido® 96mm (approx. 3³/₄"") hole spacing. No drilling required.
- Center drawers ideal for pens, pencils and other miscellaneous storage. Feature ball-bearing slide suspension.
- For conference table options, see the Preside® table tops and bases on pages 774-779. Order edge option "K".

* De-emphasized.

VALIDO® Shared Components & Accessories

GSA SIN 33721



Icon Legend on page 19

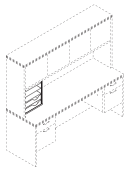

Not available in two-tone laminates

DESCRIPTION**Vertical Paper Manager**14⁷/₈"W x 10⁷/₈"D x 19¹¹/₁₆"H

NOTES: Keeps papers, files, and books neatly organized and within easy reach from a seated position. Designed for desk, credenza, and return tops. Fits under stack-on storage models. Two pullout drawers and three fixed shelves. Not available in pattern laminate colors. Ships fully assembled. For additional information see page 844.

❗ When used in conjunction with wall mounted storage cabinets, the top of the wall mounted storage cabinets must be positioned a minimum of 68³/₈" above the floor.

SPECIFYING EXAMPLE: HLVP M1.N**MODEL****SHIP WEIGHT****CUBE****LIST PRICE****HLVPM1**

27

2.8

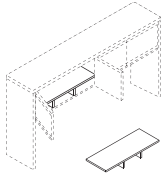
\$327**Stacked Paper Management**32¹/₂"W x 12⁵/₈"D x 4¹/₄"H

NOTES: Segments and organizes stack-on and wall mount storage compartments, as well as bookcase shelves. Unit can be used in Models H115327, H11534, H115322, H115321, H115382 and H115381. In some cases, installation may require removing the stack-on or wall mount storage doors. For additional information see page 845.

❗ Black (P) only.

HLVPM2

22

1.25

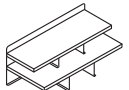
\$163

Not available in two-tone laminate

**Desktop Storage Terrace**26¹/₂"W x 12¹/₂"D x 10¹/₂"H

NOTES: Keeps work-in-process, priority files, loose pages, and mail neatly organized and in view. Mixed material design comprised of sturdy laminate shelves with metal back and support panels. Not available in two-tone laminate combination or pattern laminate colors. Choose from Platinum Metallic (T1), Black (P), and Charcoal (S) for the metal components.

Sized to fit in stack-on and wall mounted storage cabinets in 10500, 10700, Valido, 94000, and 38000 Series. Fits in Voi stack-on and overhead cabinets except for 48"W or smaller sliding door models. For additional information see page 844.

Specify: Model.Laminate.Paint

SPECIFYING EXAMPLE: HLDST1.N.T1**HLDST1**

24

1.1

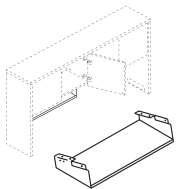
\$306**Hanging Paper Shelf**28¹/₈"W x 11⁷/₈"D x 4⁵/₈"H

NOTES: Maximizes worksurface space; de-clutters desktop while placing priority communications and active project folders within easy reach. Angled design allows contents to be distinguished at a glance. Mixed material styling features strong painted metal frame with a frosted shelf.

Attaches quickly and easily to stack-on and wall mount storage models in the following series: 10500, 10700, Valido, 94000, and Voi (except the 36"W overhead hutch with O-legs or panel mount brackets). Not for use with 38000 Series.

For additional information see page 824.

Specify: Model.Paint

SPECIFYING EXAMPLE: HHPS1.T1**HHPS1**

7

2.9

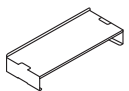
\$198**Desktop Paper Shelf**28¹/₈"W x 11⁵/₈"D x 5"H

NOTES: Organizer shelf provides a place and space for work-in-process and piling to keep worksurfaces neat and tidy. Convenient, scalable design with interlocking side supports allow two units to be stacked and integrated. Durable painted metal frame with a frosted shelf; mixed material styling matches hanging paper shelf.

Can also be used inside select overhead storage, including the following stack-on with hinged door models: 10500 and Valido 36", 42", 66", 72", 78"W and 10700 68⁵/₈"W.

For additional information see page 824.

Specify: Model.Paint

SPECIFYING EXAMPLE: HDPS1.T1**HDPS1**

7

2.9

\$198**Storage Cube**

12"W x 12"D

NOTES: For additional information see page 846.

SPECIFYING EXAMPLE: HLSL1212.P8S**HLSL1212**

1

0.3

\$294**HOW TO SPECIFY****Select Model Number**

H L V P M 1 .

Select Laminate





See page 137

N

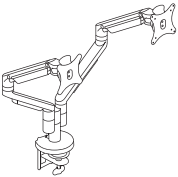
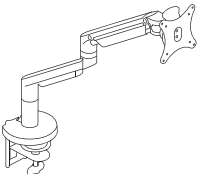
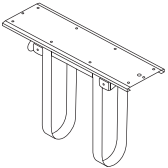
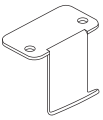

Icon Legend on page 19

Shared Components & Accessories

	DESCRIPTION	MODEL	SHIP WEIGHT	CUBE	LIST PRICE
	<p>Dual Dynamic Monitor Arm</p> <ul style="list-style-type: none"> • 150° of rotation at base with optional 360° rotation. • Arms extend 22" and retract up to 3". • Monitor mount rotates 180° and tilts +/-30°. • Monitor can be rotated from landscape to portrait position. <p>ⓘ Arms hold monitors from 6.2-18 lbs. Optional counterweight HPACW available to support monitors as low as 5 lbs. (see page 827).</p>	HMASD	17.0 Ⓢ	1.1	\$750
	<p>Single Dynamic Monitor Arm</p> <ul style="list-style-type: none"> • 180° of rotation at base with optional 360° rotation. • Arms extend 22" and retract up to 3". • Monitor mount rotates 180° and tilts +/-30°. • Monitor can be rotated from landscape to portrait position. <p>ⓘ Arms hold monitors from 6.2-18 lbs. Optional counterweight HPACW available to support monitors as low as 5 lbs. (see page 827).</p>	HMASTS	11.5 Ⓢ	0.8	\$390
	<p>360° Swivel CPU Holder with Adjustable Straps</p> <ul style="list-style-type: none"> • Supports CPUs 3¾" wide up to 64" perimeter and holds up to 75 lbs. • 360° rotation. • Ships complete and includes necessary mounting hardware and instruction sheet. <p>ⓘ Available in Black only, no specification needed.</p>	HCPU1	7.0 Ⓢ	0.2	\$243
   	<p>Back Pack Hook (10 per carton) 12"W x 14½"D x 1½"H</p> <p>NOTES: Assembly: attaches to bottom of desk with (2) screws, included. For additional information see page 846.</p> <p>ⓘ Available in Platinum Metallic finish only, no specification needed.</p>	HCLA65	10.0 Ⓢ	0.1	\$94

NOTES:

- See pages 825-826 for additional monitor arm models.

HOW TO SPECIFY

<p>Select Model Number</p>	<p>Select Finish</p> <p><i>Specify for models HMASD and HMASTS only</i></p> <p>SVR Silver BLK Black</p>
<p>HMASD</p>	<p>SVR</p>

VALIDO®

Shared Components & Accessories

GSA SIN 33721 EXCEPT AS NOTED



Icon Legend on page 19

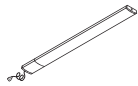

OPEN MARKET

DESCRIPTION**LED Task Lights**

17" LED Light with Power Supply (Single)

31" LED Light with Power Supply (Single)

17" LED Light with Power Supply for Daisy-chain (Starter)

31" LED Light with Power Supply for Daisy-chain (Starter)

17" LED Light with 8" Jumper Cord for Daisy-chain (Follower)

31" LED Light with 8" Jumper Cord for Daisy-chain (Follower)

Undercabinet Occupancy Sensor with 1" End to End Connector

NOTES: To use the daisy chain application, must start with model HLED17A or HLED31A. No finish specification required. Attaches magnetically to underside of overhead storage, or attaches with provided screws or double-sided tape. Occupancy sensor attaches to a single or starter LED light and will automatically turn the light off after no motion is detected for 30 minutes. Just like all the LED light models, the occupancy sensor features a soft-touch on/off switch. LED task lights have a lifetime of 50,000 hours and have a dimmer feature that allows the user to adjust the amount of light output. For additional information see page 842.

MODEL**SHIP WEIGHT****CUBE****LIST PRICE****HLED17AS**

1.2 Ⓢ

0.05

\$420**HLED31AS**

1.5 Ⓢ

0.09

\$565**HLED17A**

1.0 Ⓢ

0.05

\$462**HLED31A**

1.4 Ⓢ

0.09

\$620**HLED17AUO**

1.0 Ⓢ

0.03

\$377**HLED31AUO**

1.0 Ⓢ

0.05

\$502**HLEDOSA**

0.2 Ⓢ

0.01

\$89

Refer to page 113

OPEN MARKET

Recessed Task Light

46½"W x 3¼"D x 1⅝"H for Models H115327, H11534, H11533 and H115324

34⅝"W x 3⅞"D x 1⅝"H for Models H115323, H115322, H115382 and H115383

22⅞"W x 3⅞"D x 1⅝"H for Models H115321, H115380 and H115381

NOTES: For additional information see page 842.

HH870960

12.0 Ⓢ

1.1

\$270**HH870942**

10.0 Ⓢ

0.9

\$250**HH870930**

7.0 Ⓢ

0.6

\$231**LED Task Lights****Articulating Desk Lamp****Articulating Desk Lamp w/ Occupancy Sensor**

NOTES: For additional information see page 841.

HLED1

1.2 Ⓢ

6.5

\$402**HLED1OC**

1.2 Ⓢ

6.5

\$490**Task Desk Lamp**

NOTES: For additional information see page 841.

HLED2

0.7 Ⓢ

3.0

\$348

Black only

Field Installable Grommet

• Grommet is field installable.

• Grommet shape is round.

• Includes grommet cap and sleeve.

• Grommet cap measures 3" diameter and includes a ¾" diameter cord access hole.

• Grommet sleeve measures 2½" O.D. x ¾" thick.

• Includes instructions to locate grommet position for desks, credenzas, returns and bridges.

NOTES: For additional information see page 848.

⚠ Designed to be used in top and end panels to route/hide cords, and in modesty panels to facilitate reaching wall electrical outlets.

⚠ Black Finish

⚠ Requires a 2½" diameter hole saw and drill for installation (not included).

HFLDGRMT

0.1 Ⓢ

0.01

\$32**Field Installable Grommet**

• Grommet is field installable.

• Grommet shape is round.

• Includes grommet cap and sleeve.

• Grommet outside dimensions measure 3½" diameter and includes two cord access holes.

• Grommet sleeve measures 3" O.D. x 1" thick.

• Includes instructions to locate grommet position for desks, credenzas, returns and bridges.

NOTES: For additional information see page 848.

⚠ Designed to be used in top and end panels to route/hide cords, and in modesty panels to facilitate reaching wall electrical outlets.

⚠ Black Finish

⚠ Requires a 3" diameter hole saw and drill for installation (not included).

HFLDGRMT3

0.1 Ⓢ

0.3

\$32**NOTES:**

- See pages 150-166 for shared components.

HOW TO SPECIFY

Select
Model Number

H H 8 7 0 9 6 0 .

Select
Color



Available in Black (P) only

P

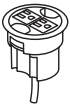
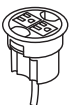

Icon Legend on page 19

Shared Components & Accessories

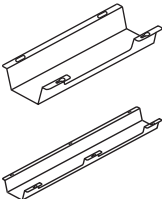
	DESCRIPTION	MODEL	SHIP WEIGHT	CUBE	LIST PRICE
	<p>Power Hub, 3" Grommet Mount, 6' Cord</p> <ul style="list-style-type: none"> Fits in 3" round grommet holes on the following product lines: 10500, 10700, Concinnity, Coordinate, and Voi desks; Abound Worksurfaces; Huddle and Motivate tables and SmartLink. Two grounded AC power outlets. Includes 6' cord with three-prong plug. Two cord pass-through holes in cap. Field installed; easy plug-and-play. UL Listed. <p>NOTES: For additional information see page 848.</p> <p>ⓘ Available in black only (no color designation so use .X - Specify: HGRMTAC.X).</p>	HGRMTAC	1.3	0.2	\$111
 	<p>3" Round Power Grommet - 2 Outlets, 10' Cord</p> <ul style="list-style-type: none"> Includes 10' cord with three-prong plug. Fits in 3" round grommet holes on the following product lines: Coordinate, Huddle, Motivate, all laminate and veneer casegoods series, and Systems Worksurfaces. Two grounded AC power outlets. Field installed with Plug-and-play ease. <p>NOTES: Power Modules will also work with standing-height applications for 10500 Series™ and Voi® desks. Optional Memory Control allows preset worksurface heights for consistency. Ships separately. Dynamic load capacity when worksurface is moving is 300 lbs.</p> <p>ⓘ Available in black finish only, no specification needed.</p>	HGRMTAC2	1.5	0.2	\$148
	<p>Power/USB Hub, 3" Grommet Mount</p> <ul style="list-style-type: none"> One grounded AC power outlet with 2 USB ports. Two cord pass-through holes in cap. Includes 6' cord with three-prong plug. Field installed; easy plug-and-play. UL Listed. <p>NOTES: For additional information see page 848.</p> <p>ⓘ Available in black only (no color designation so use .X - Specify: HGRMTUSB2.X).</p>	HGRMTUSB2	1.3 ⓘ	0.02	\$224
 SIN 33721	<p>Cable Management Troughs</p> <p>17"W - Single 17"W - 10-Pack 36"W - Single 36"W - 10-Pack</p> <ul style="list-style-type: none"> Cable management troughs ship flat packed. The troughs attach to underneath the worksurface with screws. The 17"W has one wire access cut out on the user side. The 36" has two wire access cut outs. These cut outs give users access to inside the trough without having to detach it from the worksurface. Color: Graphite. Material: Metal. TAA Compliant. <p>NOTES: For additional information see page 852.</p>	<p>HCTROUGH17 HCTROUGH1710 HCTROUGH36 HCTROUGH3610</p>	<p>2.7 ⓘ 14.0 ⓘ 4.9 ⓘ 30.0 ⓘ</p>	<p>0.5 0.5 0.9 0.9</p>	<p>\$67 \$620 \$113 \$1045</p>

HOW TO SPECIFY

Select Model Number

H G R M T A C

VALIDO® Shared Components & Accessories

GSA SIN 33721

ABI

Icon Legend on page 19

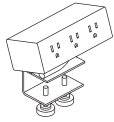

Model HPWRMOD3WC shown

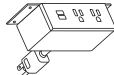

Model HPWRMOD2UWM shown

DESCRIPTION**MODEL****SHIP WEIGHT****CUBE****LIST PRICE****Power Modules**

- 3 Receptacles with Worksurface Clamp
- 3 Receptacles with Under-Worksurface Mounting Bracket
- 2 Receptacles 2 USB with Worksurface Clamp
- 2 Receptacles 2 USB with Under-Worksurface Mounting Bracket
- 6' power cord with standard three-prong plug.
- Under-worksurface mounting bracket models work with any top that has a 5" x 5" square clearance.
- Worksurface clamp models work on any top with a 4" overhang.
- UL Listed.

HPWRMOD3WC

2.3 Ⓢ

0.2

\$307**HPWRMOD3UWM**

2.3 Ⓢ

0.2

\$307**HPWRMOD2WC**

2.3 Ⓢ

0.2

\$491**HPWRMOD2UWM**

2.3 Ⓢ

0.2

\$491

- Color finish coordinates with HON's Charcoal or White. Specify *STRM* for Storm or *SNW* for Snow when ordering. Example: *HPWRMOD3WC.STRM*.

Power & Data Center

- 2 Receptacles 2 Data Accessory
- Standard with two receptacles and openings for two data ports.
- 6' power cord with standard three-prong plug.
- Fits on any worksurface with a 4" overhang.
- UL Listed.

HCOMDOME2

2.5 Ⓢ

0.2

\$293

- Color finish coordinates with HON's Loft. Specify *LOFT* when ordering. Example: *HCOMDOME2.LOFT*.

Under Worksurface Power Module — 4 Outlets, 10' Cord**HPWRMOD2**

1.5

0.2

\$401

- Includes 10' cord with three-prong plug.
- Fits in cable management troughs. See page 165.
- 4 outlets on side create easy access.

NOTES: Power Modules will also work with standing-height applications for 10500 Series™ and Voi® desks.

- Available in black finish only, no specification needed.

Vertebrae**HMPVWM28**

3.0

0.3

\$221

NOTES: 30"H x 3 3/8"W x 1 1/2"D. Ships unassembled.

- Clear finish. Specify "X" for finish option.

SPECIFYING EXAMPLE: HMPVWM28.X

NOTES:

- For additional information see pages 849 and 852.

HOW TO SPECIFY

Select
Model Number

H P W R M O D 3 W C

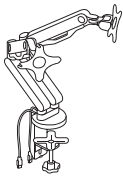
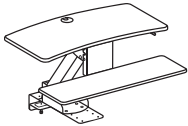
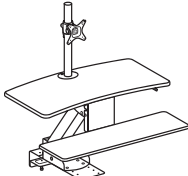
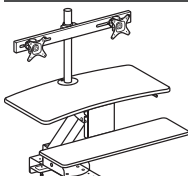
	DESCRIPTION	MODEL	SHIP WEIGHT	CUBE	LIST PRICE
	Coordinate™ Portable Desktop Riser 31"D x 5'-16½"H x 35"W NOTES: Available in Black (BLK) or White (WHT) finish. Desktop riser dimensions (without keyboard tray): 22"D x 5'-16½"H x 35"W. Keyboard tray dimensions: 9"D x 30"W. Max loading capacity is 33 lbs for the desktop riser surface and 4 lbs for the keyboard tray. Easily transition from seated to standing positions throughout the workday. Sits atop an existing desk to create sit-to-stand functionality by raising the computer. Includes keyboard tray and surface for computer monitors. HON 5-Year Limited Warranty. ! Not intended for use on mobile workstations.	HBXRISER	54.0	4.1	\$619
	Dual Monitor Arm with 2 USB Ports NOTES: Easy adjustment. Height adjusts to 17" tall. Monitor tilt and swivel capability. Enclosed cable management. Grommet or desktop mounting. Clean appearance. In some applications the Monitor Arms may extend 12 or more inches into the worksurface. For additional information see page 825. HON 5-Year Limited Warranty. ! No specification needed.	HBDMAUSB	41.9	2.6	\$441
	Coordinate™ Mounted Desktop Riser NOTES: Does not include a monitor arm and is suitable for laptops and/or monitors on their original stands. ! No specification needed.	HS1100	60.0 ☹	3.2	\$664
	Coordinate™ Mounted Desktop Riser with Single Monitor Arm NOTES: Includes a monitor arm for a single monitor. ! No specification needed.	HS1101	62.0 ☹	3.2	\$777
	Coordinate™ Mounted Desktop Riser with Dual Monitor Arm NOTES: Includes a monitor arm for dual monitors. ! No specification needed.	HS1102	63.0 ☹	3.2	\$883

NOTES FOR HS1100, HS1101, HS1102:

- These products are designed to allow the user to transition from seating position to standing position throughout the workday.
- Gas-assist lever-operated mechanism with positive stop.
- Clamp mount compatible with worksurfaces depths of 20"-30". 20" is for systems only.
- Clamp requires 3.5" of clearance along back edge of worksurface.
- Black seamless worksurfaces.
- Silver powder coated metal components.
- Lowers below worksurface level on 24" and 30"D worksurfaces.
- All models contain a large primary worksurface and a smaller keyboard / mouse surface.
- Beveled edges for sleek appearance and comfort while typing.
- Monitor arms include height, width, and swivel adjustment.
- For additional information see page 838.

- Not for use under overhead storage, with flush mounted modesty panels, or worksurfaces thinner than 1".

- ! Not recommended for use on mobile (castered) worksurfaces.

MOUNTING AND COMPATIBILITY FOR HS1100, HS1101, HS1102:

- This product is intended to be installed on commercial-grade worksurfaces in good condition.
- Compatible with freestanding worksurfaces 24"-30"D or panel-supported worksurfaces 24"-30"D.
- Not for use on mobile worksurfaces.

Clamp Mount

Use when 3.5" minimum overhang is available

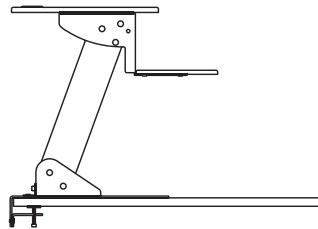
**Screw Mount**

Use when no overhang is available. Worksurface must be minimum 1" thick.

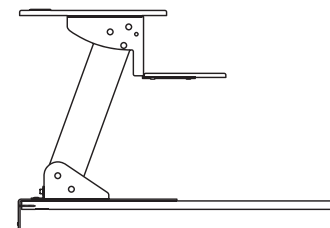

**HOW TO SPECIFY****Select Model Number**

HBXRISER.

Select FinishBLK Black
WHT White

BLK

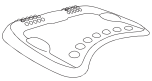
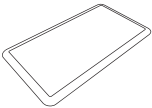
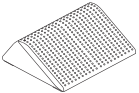

	DESCRIPTION	MODEL	SHIP WEIGHT	CUBE	LIST PRICE
	Rectangle Wobble Board — Anti-Fatigue Mat 18"D x 3"H x 22¼"W ⓘ Available in Black (T) finish ONLY. Recommended weight capacity not to exceed 250 pounds. HON 5-Year Limited Warranty. SPECIFYING EXAMPLE: HVL981.T	HVL981	10.0 Ⓔ	0.9	\$120
	Round Wobble Board — Anti-Fatigue Mat 18½"D x 2⅝"H x 18½"W ⓘ Available in Black (T) finish ONLY. Recommended weight capacity not to exceed 250 pounds. HON 5-Year Limited Warranty. SPECIFYING EXAMPLE: HVL982.T	HVL982	5.8 Ⓔ	0.6	\$102
	Ergonomic Anti-Fatigue Mat 25"D x 2¾"H x 29⅞"W ⓘ Available in Black ONLY. No specification needed. SPECIFYING EXAMPLE: HBEAFM1	HBEAFM1	7.0	1.4	\$219
	Rectangle Anti-Fatigue Mat 20"D x ¾"H x 36"W ⓘ Available in Black ONLY. No specification needed. SPECIFYING EXAMPLE: HBAFM2036	HBAFM2036	5.4	0.4	\$100
	Footrest — Anti-Slip Cover 13¾"D x 5½"H x 16"W ⓘ Available in Black (T) finish ONLY. Recommended weight capacity not to exceed 250 pounds. HON 5-Year Limited Warranty. SPECIFYING EXAMPLE: HVL991.T	HVL991	7.0 Ⓔ	0.9	\$82

HOW TO SPECIFY

Select Model Number	Select Finish
H V L 9 8 1 .	T Black
	T

VOI®



Voi® shown with Ignition® Seating.

VOI®

Voi gets you. Your needs. Your style. Your environment. Voi packs a lot of functionality into a little space, so you can maximize yours. Plus, versatile Voi integrates easily with a variety of spaces, systems — even open plans. Solidly built and strikingly designed, Voi combines classic warmth and contemporary cool with an extensive variety of laminates, colors, components and configurations. So you can create a sophisticated, professional look that is uniquely yours.

**FEATURES**

- Big. Small. Functional. Adaptable. Voi has multiple options to meet your storage needs and available space.
- To create an office look that's uniquely yours, mix things up — with tasteful modesty panels, stylish storage cubes and mixed surface materials.
- Refined scale. Layered workspaces. Together they help streamline your office to create small-footprint spaces that work BIG.
- With so many configurations and combinations, Voi® makes it easy to create a stylish, unified look across your entire office.

WORKSURFACES

L1 LAMINATES CODES

Woodgrain

- ◆ Bourbon Cherry H
- ◆ Cognac COGN
- ◆ Florence Walnut LFW1
- ◆ Harvest C
- ◆ Kingswood Walnut LK11
- ◆ Mahogany N
- ◆ Mocha MOCH
- ◆ Natural Maple D
- ◆ Pinnacle PINC
- ◆ Shaker Cherry F
- ◆ Sterling Ash LSA1

Solid

- ◆ Black P
- ◆ Charcoal S
- ◆ Designer White LDW1
- ◆ Loft LOFT

Patterned

- ◆ Sheer Mesh* A5
- ◆ Silver Mesh** B9

L2 LAMINATES*** CODES

Woodgrain

- ◆ Lowell Ash LLA1
- ◆ Natural Recon LNR1
- ◆ Phantom Ecru LPE1
- ◆ Portico Teak LPT1
- ◆ Skyline Walnut LSW1

WORKSURFACE EDGE BAND

Woodgrain

- ◆ Bourbon Cherry H
- ◆ Cognac COGN
- ◆ Designer White DW
- ◆ Florence Walnut FW
- ◆ Harvest C
- ◆ Kingswood Walnut KI
- ◆ Loft LOFT
- ◆ Lowell Ash DL
- ◆ Mahogany N
- ◆ Mocha MOCH
- ◆ Muslin T
- ◆ Natural Maple D
- ◆ Natural Recon NR
- ◆ Phantom Ecru PE
- ◆ Pinnacle PINC
- ◆ Portico Teak DP
- ◆ Shadow* SHDW
- ◆ Shaker Cherry F
- ◆ Skyline Walnut SW
- ◆ Sterling Ash SA

CHASSIS/CABINET DRAWER/DOOR FRONTS, LAMINATE END PANELS, LAYERING SHELVES AND MODESTY PANELS

L1 LAMINATES CODES

Woodgrain

- ◆ Bourbon Cherry H
- ◆ Cognac COGN
- ◆ Florence Walnut LFW1
- ◆ Harvest C
- ◆ Kingswood Walnut LK11
- ◆ Mahogany N
- ◆ Mocha MOCH
- ◆ Natural Maple D
- ◆ Pinnacle PINC
- ◆ Shaker Cherry F
- ◆ Sterling Ash LSA1

Solid

- ◆ Black P
- ◆ Charcoal S
- ◆ Designer White LDW1
- ◆ Loft LOFT

L2 LAMINATES*** CODES

Woodgrain

- ◆ Lowell Ash LLA1
- ◆ Natural Recon LNR1
- ◆ Phantom Ecru LPE1
- ◆ Portico Teak LPT1
- ◆ Skyline Walnut LSW1

WORKSURFACE GROMMETS

PLASTIC CODES

- ◆ Black P
- ◆ Brownstone EY
- ◆ Charcoal S
- ◆ Designer White DW
- ◆ Fossil EH
- ◆ Greige R
- ◆ Loft LOFT
- ◆ Muslin T3
- ◆ Platinum T1
- ◆ Shadow* SD
- ◆ Titanium T1

PULLS & FEET

PAINT CODES

- P1**
- ◆ Black P
- ◆ Designer White PJW
- P2**
- ◆ Champagne Metallic T4
- ◆ Platinum Metallic T1
- ◆ Silver PR6
- ◆ Solar Black P8X

O-LEGS, STEEL LEGS, POST LEGS, SHELF BRACKETS, SHARED LEGS, STORAGE CUBES

PAINTS CODES

- P1**
- ◆ Black P
- ◆ Brownstone P7D
- ◆ Charcoal S
- ◆ Designer White PJW
- ◆ Fossil P28
- ◆ Greige T5
- ◆ Loft LOFT
- ◆ Muslin T3
- ◆ Shadow* SHDW
- ◆ Titanium P8T
- P2**
- ◆ Champagne Metallic T4
- ◆ Platinum Metallic T1
- ◆ Silver PR6
- ◆ Solar Black P8X
- P3**
- ◆ Atom P8S
- ◆ Blossom**** P8K
- ◆ Bullseye PJF
- ◆ Cabernet**** P7T
- ◆ Conifer**** P8H
- ◆ Ember P8P
- ◆ Ion P8N
- ◆ Iris P8J
- ◆ Krypton P8F
- ◆ Regatta P8M
- ◆ Succulent**** P8A

ANGLED WOOD LEGS

- ◆ Clear Ash LA400
- ◆ Medium Ash LA484

WORKSURFACE LAMINATES	CODES	EDGE BAND OPTIONS					
		Matching Edge	Designer White (DW)	Loft (LOFT)	Muslin (T)	Shadow (SHDW)	Black (P)
Black	P						*
Bourbon Cherry	H	•	•		•		
Charcoal	S	•					
Cognac	COGN	•	•		•		
Designer White	LDW1		•				
Harvest	C	•	•		•		
Loft	LOFT			•			
Lowell Ash	LLA1	•	•	•	•		
Mahogany	N	•		•		•	
Mocha	MOCH	•	•		•		
Natural Maple	D	•	•	•	•		
Natural Recon	LNR1	•	•	•	•		
Phantom Ecru	LPE1	•	•	•	•		
Pinnacle	PINC	•	•	•	•		
Portico Teak	LPT1	•	•	•	•		
Shaker Cherry	F	•	•	•	•	•	
Sheer Mesh	A5				•		
Silver Mesh	B9			•			
Skyline Walnut	LSW1	•	•	•	•		
Sterling Ash	LSA1	•	•	•	•		•
Kingswood Walnut	LK11	•	•	•	•		•
Florence Walnut	LFW1	•	•	•	•		•

* Sheer Mesh laminate will have Muslin Edgeband. Sheer Mesh NOT available on Chassis/Cabinet, Drawer/Door Fronts, Laminate End Panels, Layering Shelves and Modesty Panels.

** Silver Mesh laminate will have Loft Edgeband. Silver Mesh NOT available on Chassis/Cabinet, Drawer/Door Fronts, Laminate End Panels, Layering Shelves and Modesty Panels.

*** Storage chassis that are specified in L2 laminates and are longer than 60" W will ship with back panels that are horizontal grain.

**** TREND COLORS: These colors are intended to be an inspirational option for the trending market. Product application is limited and color availability is approximately two years to coincide with evolving workplace trends.

◆◆◆ For lead time information see page 19.

* De-emphasized

VOI® Laminate Typicals



Icon Legend on page 19

QTY	DESCRIPTION	MODEL	LIST PRICE	PRICE EXTENSION
1	External Channel 54"W	HLSLZ5SC66	\$101	\$101
1	Rectangle Worksurface 24"D x 66"W	HLSLR2466	\$380	\$380
1	Low Credenza (Right hand drawers) 60"W x 20"D x 21½"H	HLSL2060LR2	\$1,254	\$1,254
1	Layering Shelf 60"W x 14½"D x 5½"H	HLSL1460LS	\$364	\$364
2	O-Leg Support for Worksurface (1 pack) 24"D x 28½"H	HLSL24280	\$316	\$632
1	Overhead Cabinet with Wall Bracket with One Sliding Door 60"W x 14¼"D x 14"H	HLSL1460S	\$1,311	\$1,311
TOTAL:			\$4,042	

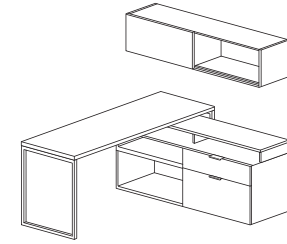
**SMALL FOOTPRINT****66" x 60"**

QTY	DESCRIPTION	MODEL	LIST PRICE	PRICE EXTENSION
1	External Channel 54"W	HLSLZ5SC66	\$101	\$101
1	Rectangle Worksurface 24"D x 66"W	HLSLR2466	\$380	\$380
1	Low Credenza (2 file/2 box) 60"W x 20"D x 21½"H	HLSL2060LD4	\$1,462	\$1,462
2	O-Leg Support for Worksurface (1 pack) 24"D x 28½"H	HLSL24280	\$316	\$632
1	Overhead Cabinet with 4 Doors 60"W x 14¼"D x 14"H	HLSL1460D	\$1,161	\$1,161
1	O-Leg Support for Overhead Cabinet 14½"D x 20½"H for 65"H Overhead Cabinet	HLSL650S	\$468	\$468
TOTAL:			\$4,204	

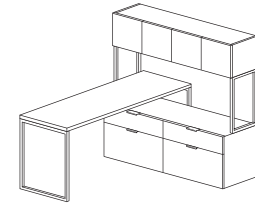
**SMALL FOOTPRINT****66" x 60"**

QTY	DESCRIPTION	MODEL	LIST PRICE	PRICE EXTENSION
1	Low Credenza, Right Hand Drawers, Footed 60"W x 20"D x 24½"H	HLSL2060LR2F	\$1,324	\$1,324
1	Cube Bundle A	HLSL15-SOO	\$294	\$294
2	Drawer Cube 15"W x 13"D x 4"H	HLSL154LSD	\$221	\$442
1	Voi® Shelf 30"W x 13"D	HLSLR1330	\$187	\$187
1	Angled Steel Leg 29"H	HLSL28AM2	\$323	\$323
1	4"H Steel Stanchion	HLSL4AM2	\$151	\$151
1	Rectangle Worksurface 72"W x 30"D	HLSLR3072	\$469	\$469
1	Mixed Material Floating Modesty Panel 42"W x 14"H	HLSL4214MM	\$811	\$811
TOTAL:			\$4,001	

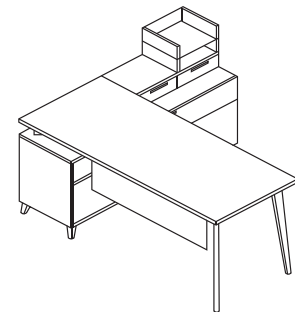
**SMALL FOOTPRINT****60" W x 72" D**



Icon Legend on page 19

VOI®

Laminate Typicals

DESKS

QTY	DESCRIPTION	MODEL	LIST PRICE	PRICE EXTENSION
1	Mixed Material Floating Modesty Panel 42"W x 14"H	HLSL4214MM	\$811	\$811
1	Rectangular Worksurface 48"W x 24"D	HLSLR2448	\$300	\$300
2	Drawer Cube 15"W x 13"D x 4"H	HLSL154LSD	\$221	\$442
1	Cube Bundle A	HLSL15-SOO	\$294	\$294
2	Angled Steel Leg 29"H	HLSL28AM2	\$323	\$646
1	Rectangle Worksurface 60"W x 30"D	HLSLR3060	\$402	\$402
1	Voi® Shelf 30"W x 13"D	HLSLR1330	\$187	\$187
1	Support Pedestal 24"W x 28"D	HLSL2428B	\$762	\$762
TOTAL:			\$3,844	

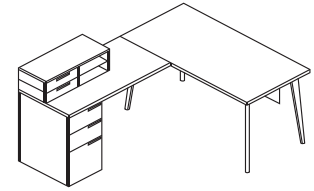

SMALL FOOTPRINT
78"W x 60"D

QTY	DESCRIPTION	MODEL	LIST PRICE	PRICE EXTENSION
1	Box/File Pedestal, Footed 16"W x 20"D x 28½"H	HLSL2016FP2	\$850	\$850
2	Drawer Cube 15"W x 13"D x 4"H	HLSL154LSD	\$221	\$442
1	Cube Bundle A	HLSL15-SOO	\$294	\$294
1	Short Open Cube 15"W x 13"D x 4"H	HLSL154LSO	\$147	\$147
1	Voi® Shelf 30"W x 13"D	HLSLR1330	\$187	\$187
2	Voi® Shelf 45"W x 13"D	HLSLR1345	\$228	\$456
1	4"H Steel Stanchion	HLSL4AM2	\$151	\$151
1	Rectangle Worksurface 72"W x 30"D	HLSLR3072	\$469	\$469
1	Rectangular Worksurface 48"W x 24"D	HLSLR2448	\$300	\$300
1	Shelf Brackets	HLSLSB	\$96	\$96
1	Mixed Material Floating Modesty Panel 54"W x 14"H	HLSL5414MM	\$974	\$974
2	Angled Wood Leg 29"H	HLSL28AW2	\$420	\$840
TOTAL:			\$5,206	

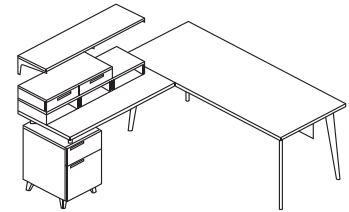

SMALL FOOTPRINT WITH SHELF
78"W x 72"D

QTY	DESCRIPTION	MODEL	LIST PRICE	PRICE EXTENSION
1	Low Credenza, 2 File/Open, Footed 60"W x 20"D x 24½"H	HLSL2060LD2F	\$1,440	\$1,440
1	Cabinet Cube, Left Handed 15"W x 13"D x 12"H	HLSL1512LSCL	\$221	\$221
1	Short Open Cube 15"W x 13"D x 4"H	HLSL154LSO	\$147	\$147
2	Drawer Cube 15"W x 13"D x 4"H	HLSL154LSD	\$221	\$442
1	Voi® Shelf 45"W x 13"D	HLSLR1345	\$228	\$228
2	Angled Steel Leg 29"H	HLSL28AM2	\$323	\$646
1	Rectangle Worksurface with Stiffener 60"W x 30"D	HLSLR3060W	\$473	\$473
1	Mixed Material Floating Modesty Panel 42"W x 14"H	HLSL4214MM	\$811	\$811
TOTAL:			\$4,408	

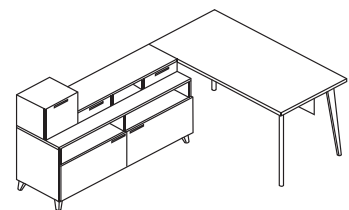

SMALL FOOTPRINT
90"W x 60"D

VOI® Laminate Typicals



Icon Legend on page 19

QTY	DESCRIPTION	MODEL	LIST PRICE	PRICE EXTENSION
1	Cube Bundle A	HLSL15-SOO	\$294	\$294
2	Angled Steel Leg 29"H	HLSL28AM2	\$323	\$646
1	Rectangle Worksurface 72"W x 30"D	HLSLR3072	\$469	\$469
1	Mixed Material Floating Modesty Panel 54"W x 14"H	HLSL5414MM	\$974	\$974
1	Low Credenza, 2 File/Open, Footed 60"W x 20"D x 24½"H	HLSL2060LD2F	\$1,440	\$1,440
4	Drawer Cube 15"W x 13"D x 4"H	HLSL154LSD	\$221	\$884
2	Voi® Shelf 30"W x 13"D	HLSLR1330	\$187	\$374
TOTAL:			\$5,081	

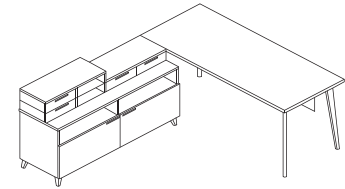

**SMALL FOOTPRINT WITH
SIX CUBES**
90"W x 72"D

QTY	DESCRIPTION	MODEL	LIST PRICE	PRICE EXTENSION
1	Low Credenza, 2 File/Open, Footed 60"W x 20"D x 24½"H	HLSL2060LD2F	\$1,440	\$1,440
1	Low Credenza, Open, Footed 30"W x 20"D x 24½"H	HLSL2030LD0F	\$924	\$924
1	Cube Bundle C	HLSL15-SODLOC	\$765	\$765
2	Voi® Shelf 45"W x 13"D	HLSLR1345	\$228	\$456
1	Angled Steel Leg 29"H	HLSL28AM2	\$323	\$323
1	4"H Steel Stanchion	HLSL4AM2	\$151	\$151
1	Rectangle Worksurface 72"W x 30"D	HLSLR3072	\$469	\$469
1	Mixed Material Floating Modesty Panel 42"W x 14"H	HLSL4214MM	\$811	\$811
TOTAL:			\$5,339	

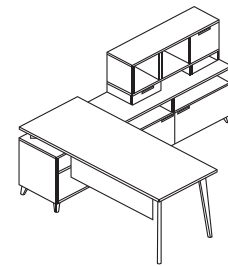

**MEDIUM FOOTPRINT WITH
CUBE BUNDLE C**
90"W x 72"D

QTY	DESCRIPTION	MODEL	LIST PRICE	PRICE EXTENSION
1	External Channel 48"W	HLSLZ5SC60	\$98	\$98
1	Rectangle Worksurface 30"D x 72"W	HLSLR3072	\$469	\$469
1	Rectangle Worksurface 20"D x 72"W	HLSLR2072	\$392	\$392
1	Low Credenza (2 file drawers) 60"W x 20"D x 21½"H	HLSL2060LD2	\$1,370	\$1,370
1	Overhead Cabinet - Metal Frame, Glass Doors 72"W x 14¼"D x 14"H	HLSL1472M	\$2,134	\$2,134
1	O-Leg Stack-on Storage Support (2 pack) 65"H	HLSL65OS	\$468	\$468
1	O-Leg Support for Worksurface (1 pack) 20"D x 28½"H	HLSL2028O	\$292	\$292
2	O-Leg Support for Worksurface (1 pack) 30"D x 28½"H	HLSL3028O	\$352	\$704
1	Box/Box/File Pedestal Support 20"D x 28½"H	HLSL2028B	\$689	\$689
1	Mixed Material Floating Modesty Panel 60"W x 14"H	HLSL6014MM	\$1,113	\$1,113
1	Storage Cube 12" x 12"	HLSL1212	\$294	\$294
TOTAL:			\$8,023	

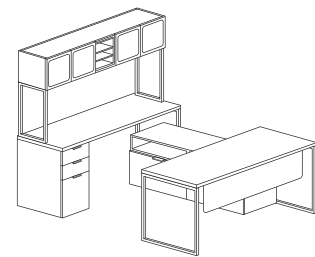

PRIVATE OFFICE
92" x 72"



Icon Legend on page 19

VOI®

Laminate Typicals

DESKS

QTY	DESCRIPTION	MODEL	LIST PRICE	PRICE EXTENSION
2	Low Credenza, 2 File/Open, Footed 60"W x 20"D x 24½"H	HLSL2060LD2F	\$1,440	\$2,880
2	Low Credenza, Open, Footed 30"W x 20"D x 24½"H	HLSL2030LD0F	\$924	\$1,848
1	Cube Bundle E	HLSL15-SO0DDLOC	\$1,133	\$1,133
2	Drawer Cube 15"W x 13"D x 4"H	HLSL154LSD	\$221	\$442
2	Short Open Cube 15"W x 13"D x 4"H	HLSL154LSO	\$147	\$294
1	Tall Open Cube 15"W x 13"D x 12"H	HLSL1512LSO	\$176	\$176
1	Cabinet Cube, Left Handed 15"W x 13"D x 12"H	HLSL1512LSCL	\$221	\$221
2	Mixed Material Floating Modesty Panel 42"W x 14"H	HLSL4214MM	\$811	\$1,622
2	Voi® Shelf 30"W x 13"D	HLSLR1330	\$187	\$374
4	Voi® Shelf 45"W x 13"D	HLSLR1345	\$228	\$912
2	Angled Steel Leg 29"H	HLSL28AM2	\$323	\$646
2	4"H Steel Stanchion	HLSL4AM2	\$151	\$302
2	Rectangle Worksurface 72"W x 30"D	HLSLR3072	\$469	\$938
TOTAL:				\$11,788

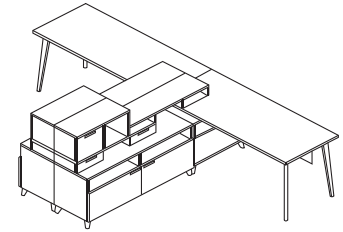

**LARGE FOOTPRINT
ADJACENT TEAMING**
90"W x 144"D

QTY	DESCRIPTION	MODEL	LIST PRICE	PRICE EXTENSION
1	Box/Box/File Pedestal Support 30"D x 28"H	HLSL3028B	\$859	\$859
1	Rectangle Worksurface 36"D x 72"W	HLSLR3672	\$611	\$611
1	End Panel Support 24"D x 28½"H	HLSL2428E	\$203	\$203
1	End Panel Support 30"D x 28½"H	HLSL3028E	\$216	\$216
1	Rectangle Worksurface 20"D x 42"W	HLSLR2042	\$262	\$262
1	Rectangle Worksurface 24"D x 72"W	HLSLR2472	\$394	\$394
1	Mixed Material Floating Modesty Panel 42"W x 14"H	HLSL4214MM	\$811	\$811
1	Lateral File 36"W x 24"D x 28½"H	HLSL2430L	\$1,184	\$1,184
1	Overhead Cabinet - Metal Frame, Glass Doors 72"W x 14¼"D x 14"H	HLSL1472M	\$2,284	\$2,284
1	Storage Cube 12" x 12"	HLSL1212	\$294	\$294
TOTAL:				\$7,118

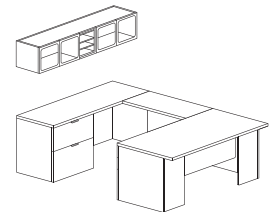

PRIVATE OFFICE
102" x 72"

VOI® Laminate Typicals



Icon Legend on page 19

QTY	DESCRIPTION	MODEL	LIST PRICE	PRICE EXTENSION
1	Low Credenza, 2 File/Open, Footed 60"W x 20"D x 24½"H	HLSL2060LD2F	\$1,440	\$1,440
1	Low Credenza, 1 File/Open, Footed 30"W x 20"D x 24½"H	HLSL2030LD1F	\$1,020	\$1,020
1	Left Hand Door, Footed 18"W x 20"D x 4"H	HLSLW084LF	\$1,283	\$1,283
2	Drawer Cube 15"W x 13"D x 4"H	HLSL154LSD	\$221	\$442
2	Cube Bundle A	HLSL15-SOO	\$294	\$588
1	Cube Bundle D	HLSL15-SDDLCC	\$884	\$884
2	Voi® Shelf 45"W x 13"D	HLSLR1345	\$228	\$456
2	Voi® Shelf 30"W x 13"D	HLSLR1330	\$187	\$374
2	Angled Wood Leg 29"H	HLSL28AW2	\$420	\$840
1	Rectangle Top, Knife Edge 72"W x 30"D	HLSLR3072J	\$644	\$644
1	Mixed Material Floating Modesty Panel 54"W x 14"H	HLSL5414MM	\$974	\$974
TOTAL:			\$8,945	

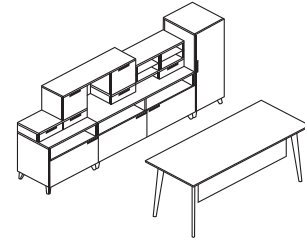

**PRIVATE OFFICE WITH
TABLE DESK**
108" W x 50" D

QTY	DESCRIPTION	MODEL	LIST PRICE	PRICE EXTENSION
1	Tower (Right hand drawers/Left hand door) 24"W x 20"D x 65"H, Left	HLSLW046L	\$2,188	\$2,188
1	Layering Shelf 60"W x 14½"D x 5½"H	HLSL1460LS	\$364	\$364
1	Rectangle Worksurface 30"D x 72"W	HLSLR3072	\$469	\$469
1	Mixed Material Floating Modesty Panel 42"W x 14"H	HLSL4214MM	\$811	\$811
2	O-Leg Support for Worksurface (1 pack) 30"D x 28½"H	HLSL30280	\$352	\$704
1	Low Credenza (2 file/2 box) 60"W x 20"D x 21½"H	HLSL2060LD4	\$1,462	\$1,462
1	Low Credenza (Open/Right hand drawers) 60"W x 20"D x 21½"H	HLSL2060LR2	\$1,254	\$1,254
1	Credenza Cushion 20"W x 30"D x 1"H	HLSL2030CH2	\$372	\$372
TOTAL:			\$7,624	

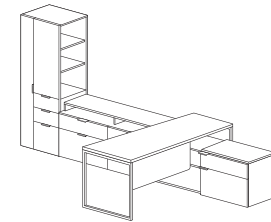

PRIVATE OFFICE
144" x 72"

QTY	DESCRIPTION	MODEL	LIST PRICE	PRICE EXTENSION
1	Personal Storage Tower (Left handed) 24"W x 24"D x 65"H	HLSLW446LP	\$2,609	\$2,609
2	Lateral File 30"W x 24"D x 28½"H	HLSL2430L	\$1,184	\$2,368
1	Rectangle Worksurface 24"D x 60"W	HLSLR2460	\$351	\$351
1	Rectangle Worksurface 30"D x 72"W	HLSLR3072	\$469	\$469
1	Rectangle Worksurface 24"D x 54"W	HLSLR2454	\$323	\$323
2	O-Leg Support for Worksurface (1 pack) 30"D x 28½"H	HLSL30280	\$352	\$704
2	Overhead Cabinet with Wall Bracket with One Sliding Door 72"W x 14½"D x 13"H	HLSL1472S	\$1,550	\$3,100
2	Storage Cube 12" x 12"	HLSL1212	\$294	\$588
1	External Channel 60"W	HLSLZ5SC72	\$110	\$110
TOTAL:			\$10,622	

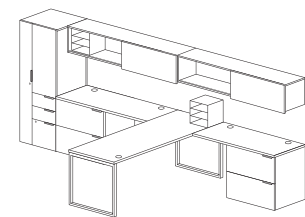

OPEN PLAN
168" x 72"



Icon Legend on page 19

QTY	DESCRIPTION	MODEL	LIST PRICE	PRICE EXTENSION
1	Low Credenza, Left Hand Drawers, Footed 60"W x 20"D x 24½"H	HLSL2060LL2F	\$1,324	\$1,324
1	Low Credenza, 1 File/1 Box, Footed 30"W x 20"D x 24½"H	HLSL2030LD2F	\$1,127	\$1,127
4	Drawer Cube 15"W x 13"D x 4"H	HLSL154LSD	\$221	\$884
3	Cube Bundle A	HLSL15-SOO	\$294	\$882
1	Cabinet Cube, Right Handed 15"W x 13"D x 12"H	HLSL1512LSCR	\$221	\$221
1	Cabinet Cube, Left Handed 15"W x 13"D x 12"H	HLSL1512LSCL	\$221	\$221
1	Low Credenza, Right Hand Drawers, Footed 60"W x 20"D x 24½"H	HLSL2060LR2F	\$1,324	\$1,324
1	Voi® Shelf 30"W x 13"D	HLSLR1330	\$187	\$187
4	Voi® Shelf 45"W x 13"D	HLSLR1345	\$228	\$912
2	Angled Steel Leg 29"H	HLSL28AM2	\$323	\$646
2	4"H Steel Stanchion	HLSL4AM2	\$151	\$302
2	Rectangle Worksurface 72"W x 30"D	HLSLR3072	\$469	\$938
2	Mixed Material Floating Modesty Panel 42"W x 14"H	HLSL4214MM	\$811	\$1,622
TOTAL:			\$10,590	

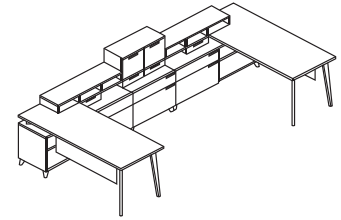

**LARGE TEAMING STATION
WITH ENHANCED STORAGE**
150" W x 72" D

QTY	DESCRIPTION	MODEL	LIST PRICE	PRICE EXTENSION
4	External Channel 48"W	HLSLZ55C60	\$98	\$392
2	Accelerate® Raceway Panels 42½"H x 60"W	HETP4260FP	\$425	\$850
2	Accelerate® Raceway Panels 50"H x 60"W	HETP5060FP	\$474	\$948
2	Electrical Power Harness, 3-1 & 2-2 60"W	HH871260	\$214	\$428
4	Duplex Receptacle Circuit 3, 3-1	HH871503	\$43	\$172
1	Power In-feed	HH879072	\$227	\$227
2	Low Credenza (Right hand drawers) 60"W x 20"D x 21½"H	HLSL2060LR2	\$1,254	\$2,508
2	Low Credenza (Left hand drawers) 60"W x 20"D x 21½"H	HLSL2060LL2	\$1,254	\$2,508
4	Credenza Cushion 20"W x 30"D x 1"H	HLSL2030CH2	\$372	\$1,488
4	O-Leg Support for Worksurface (1 pack) 30"D x 28½"H	HLSL2428O	\$316	\$1,264
2	Left O-Leg to Panel Bracket	HLSLPBL	\$100	\$200
2	Right O-Leg to Panel Bracket	HLSLPBR	\$100	\$200
4	Accelerate® Top Cap 60"W	HETC60	\$81	\$324
2	Accelerate® Variable Height Finishing Kit	HECVH07P	\$51	\$102
2	Accelerate® Finished End Cover 50"H	HEFEC50P	\$56	\$112
2	Accelerate® Finished End Cover 42½"H	HEFEC42P	\$52	\$104
1	Accelerate® "X" Connector 50"H	HEC50PX	\$141	\$141
4	O-Leg Support for Worksurface 24"D x 7"H	HLSL247O	\$213	\$852
4	Rectangle Worksurface 24"D x 60"W	HLSLR2460	\$351	\$1,404
TOTAL:			\$14,224	

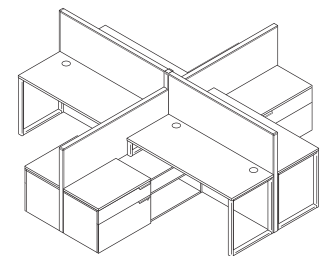

OPEN PLAN
120" x 120"

VOI® Laminate Typicals



Icon Legend on page 19

QTY	DESCRIPTION	MODEL	LIST PRICE	PRICE EXTENSION
4	External Channel 60"W	HLSLZ55C72	\$110	\$440
4	Rectangle Worksurface 24"D x 72"W	HLSLR2472	\$394	\$1,576
2	O-Leg Shared Support for Low Credenzas	HLSL247SL	\$266	\$532
2	Double Depth O-Leg Support for Worksurface 48"D x 28½"H	HLSL4828O	\$597	\$1,194
2	Low Credenza (Right hand drawers) 60"W x 20"D x 21½"H	HLSL2060LR2	\$1,254	\$2,508
2	Low Credenza (Left hand drawers) 60"W x 20"D x 21½"H	HLSL2060LL2	\$1,254	\$2,508
2	Above/Below Privacy Screen 60"W x 28½"H	HLSL2860	\$1,397	\$2,794
TOTAL:			\$11,552	

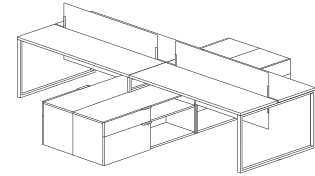

OPEN PLAN
144" x 120"

QTY	DESCRIPTION	MODEL	LIST PRICE	PRICE EXTENSION
1	Low Credenza, Right Hand Drawers, Footed 60"W x 20"D x 24½"H	HLSL2060LR2F	\$1,324	\$1,324
1	Low Credenza, Left Hand Drawers, Footed 60"W x 20"D x 24½"H	HLSL2060LL2F	\$1,324	\$1,324
1	Cube Bundle A	HLSL15-SOO	\$294	\$294
2	Drawer Cube 15"W x 13"D x 4"H	HLSL154LSD	\$221	\$442
1	Cabinet Cube, Right Handed 15"W x 13"D x 12"H	HLSL1512LSCR	\$221	\$221
1	Cabinet Cube, Left Handed 15"W x 13"D x 12"H	HLSL1512LSCL	\$221	\$221
3	Voi® Shelf 30"W x 13"D	HLSLR1330	\$187	\$561
4	Angled Steel Leg 29"H	HLSL28AM2	\$323	\$1,292
2	Rectangle Top, Knife Edge 60"W x 30"D	HLSLR3060J	\$550	\$1,100
TOTAL:			\$6,779	

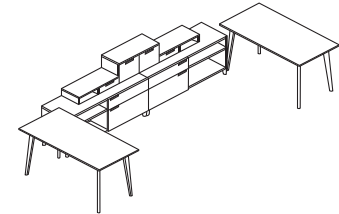

LARGE FOOTPRINT
TEAMING
180" W x 80" D



Icon Legend on page 19

VOI® Bundles Typicals

DESKS

VT6030MB

Worksurface is Silver Mesh, Mobile Pedestal is Harvest, O-Leg Supports and grommets are Platinum Metallic.

QTY	DESCRIPTION	MODEL	LIST PRICE	PRICE EXTENSION
1	Rectangle Worksurface with External Support Channel	HLSLR3060W*	\$473	\$473
2	O-Leg Support for Worksurface	HLSL30280	\$356	\$712
1	Mobile Pedestal	HLSL2016MP2	\$794	\$794
TOTAL:			\$1,979	

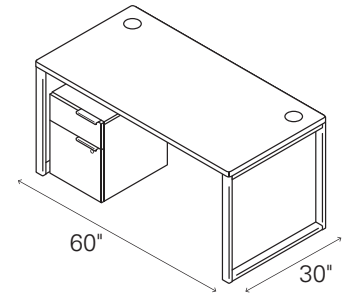
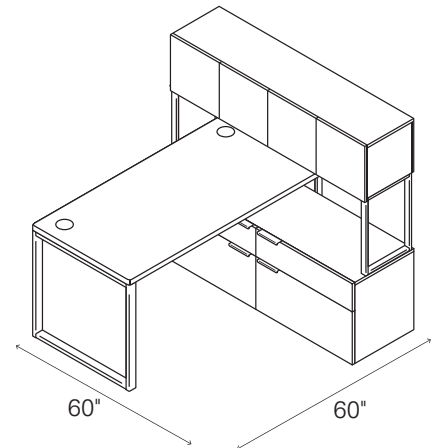

**TABLE DESK WITH MOBILE PEDESTAL
(NON-HANDED)**

VS6060L1B

Worksurface is Silver Mesh, Low Credenza and Overhead Cabinet are Harvest, O-Leg Supports and grommets are Platinum Metallic.

QTY	DESCRIPTION	MODEL	LIST PRICE	PRICE EXTENSION
1	Rectangle Worksurface with External Support Channel	HLSLR3060W*	\$473	\$473
2	O-Leg Support for Worksurface	HLSL30280	\$356	\$712
1	Low Credenza, 2 File/2 Box	HLSL2060LD4	\$1,462	\$1,462
1	Overhead Cabinet with 4 Doors	HLSL1460D	\$1,161	\$1,161
1	O-Leg Support for Overhead Cabinet (Pair)	HLSL650S	\$472	\$472
TOTAL:			\$4,280	



**SMALL FOOTPRINT L-STATION
(NON-HANDED)**

VS6060L6B

Worksurface is Silver Mesh, Low Credenza and Layering Shelf are Harvest, O-Leg Supports and grommets are Platinum Metallic.

QTY	DESCRIPTION	MODEL	LIST PRICE	PRICE EXTENSION
1	Rectangle Worksurface with External Support Channel	HLSLR3060W*	\$473	\$473
2	O-Leg Support for Worksurface	HLSL30280	\$356	\$712
1	Low Credenza, Right-hand Drawers	HLSL2060LR2	\$1,254	\$1,254
1	Layering Shelf	HLSL1460LS	\$364	\$364
TOTAL:			\$2,803	

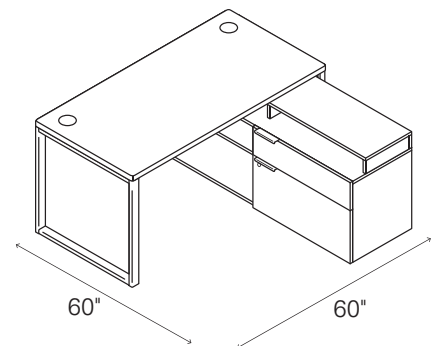

**SMALL FOOTPRINT L-STATION
(RIGHT HANDED, LOW CREDENZA)**

*Worksurface model **HLSLR3060W** can only be ordered with bundles.

VOI® Bundles Typical



Icon Legend on page 19

VS6060L4B

Worksurface is Silver Mesh, Low Credenza and Layering Shelf are Harvest, O-Leg Supports and grommets are Platinum Metallic.

QTY	DESCRIPTION	MODEL	LIST PRICE	PRICE EXTENSION
1	Rectangle Worksurface with External Support Channel	HLSLR3060W*	\$473	\$473
2	O-Leg Support for Worksurface	HLSL30280	\$356	\$712
1	Low Credenza, Left-hand Drawers	HLSL2060LL2	\$1,254	\$1,254
1	Layering Shelf	HLSL1460LS	\$364	\$364
TOTAL:			\$2,803	

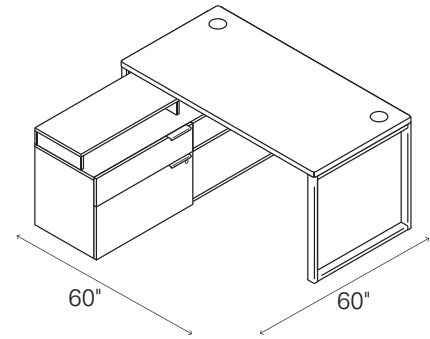

**SMALL FOOTPRINT L-STATION
(LEFT HANDED, LOW CREDENZA)**

VS6060L5B

Worksurface is Silver Mesh, Low Credenza and Overhead Cabinet are Harvest, O-Leg Supports and grommets are Platinum Metallic.

QTY	DESCRIPTION	MODEL	LIST PRICE	PRICE EXTENSION
1	Rectangle Worksurface with External Support Channel	HLSLR3060W*	\$473	\$473
2	O-Leg Support for Worksurface	HLSL30280	\$356	\$712
1	Low Credenza, Right-hand Drawers	HLSL2060LR2	\$1,254	\$1,254
1	Overhead Cabinet with 4 Doors	HLSL1460D	\$1,161	\$1,161
1	O-Leg Support for Overhead Cabinet (Pair)	HLSL650S	\$472	\$472
TOTAL:			\$4,072	

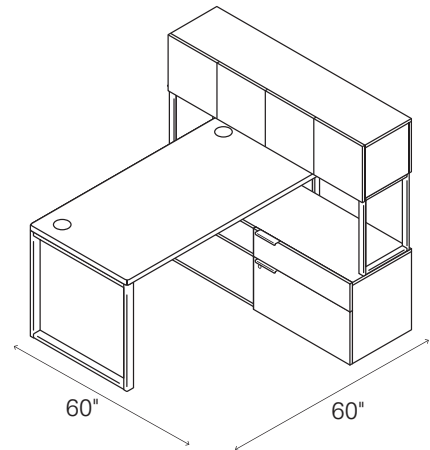

**SMALL FOOTPRINT L-STATION
(RIGHT HANDED, LOW CREDENZA)**

VS6060L3B

Worksurface is Silver Mesh, Low Credenza and Overhead Cabinet are Harvest, O-Leg Supports and grommets are Platinum Metallic.

QTY	DESCRIPTION	MODEL	LIST PRICE	PRICE EXTENSION
1	Rectangle Worksurface with External Support Channel	HLSLR3060W*	\$473	\$473
2	O-Leg Support for Worksurface	HLSL30280	\$356	\$712
1	Low Credenza, Left-hand Drawers	HLSL2060LL2	\$1,254	\$1,254
1	Overhead Cabinet with 4 Doors	HLSL1460D	\$1,161	\$1,161
1	O-Leg Support for Overhead Cabinet (Pair)	HLSL650S	\$472	\$472
TOTAL:			\$4,072	

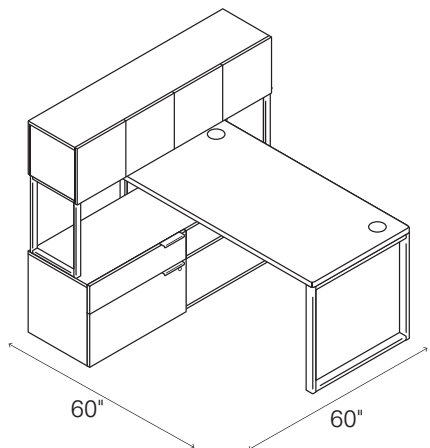

**SMALL FOOTPRINT L-STATION
(LEFT HANDED, LOW CREDENZA)**

*Worksurface model **HLSLR3060W** can only be ordered with bundles.



Icon Legend on page 19

VOI® Bundles Typicals

VS6060L2B

Worksurface is Silver Mesh, Low Credenza and Layering Shelf are Harvest, O-Leg Supports and grommets are Platinum Metallic.

QTY	DESCRIPTION	MODEL	LIST PRICE	PRICE EXTENSION
1	Rectangle Worksurface with External Support Channel	HLSLR3060W*	\$473	\$473
2	O-Leg Support for Worksurface	HLSL30280	\$356	\$712
1	Low Credenza, 2 File/2 Box	HLSL2060LD4	\$1,462	\$1,462
1	Layering Shelf	HLSL1460LS	\$364	\$364
TOTAL:				\$3,011

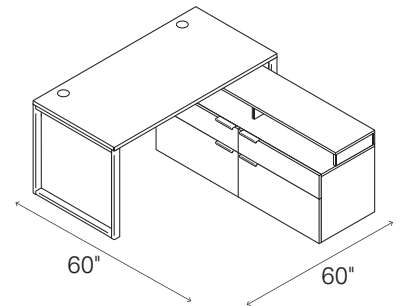

**SMALL FOOTPRINT L-STATION
(LOW CREDENZA, LAYERING SHELF)
(NON-HANDED)**

VC7260L2B

Worksurface is Silver Mesh, Low Credenza is Harvest, O-Leg Supports and grommets are Platinum Metallic.

QTY	DESCRIPTION	MODEL	LIST PRICE	PRICE EXTENSION
1	Rectangle Worksurface with External Support Channel	HLSLR3072W*	\$551	\$551
2	O-Leg Support for Worksurface	HLSL30280	\$356	\$712
1	Low Credenza, 2 File/2 Box	HLSL2060LD4	\$1,462	\$1,462
TOTAL:				\$2,725

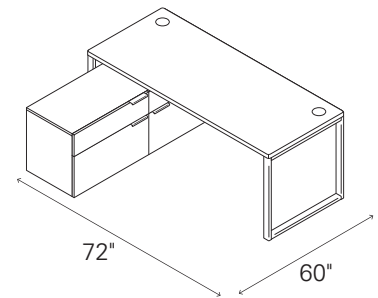

**CONTEMPORARY L-STATION
(NON-HANDED)**

*Worksurface models **HLSLR3060W** and **HLSLR3072W** can only be ordered with bundles.

VOI® SPECIFYING/DESIGN GUIDE

This Specifying Guide is designed to walk you through the steps when choosing the Voi desks elements that will meet your particular workplace needs. From private office to open plan, there are endless combinations that will fit your style and need.

Regardless of the application, Voi presents an integrated, unified aesthetic for the entire workplace.

The step-by-step instructions make it easy to specify elements that personalize workspaces and achieve the right mix of functionality and style.

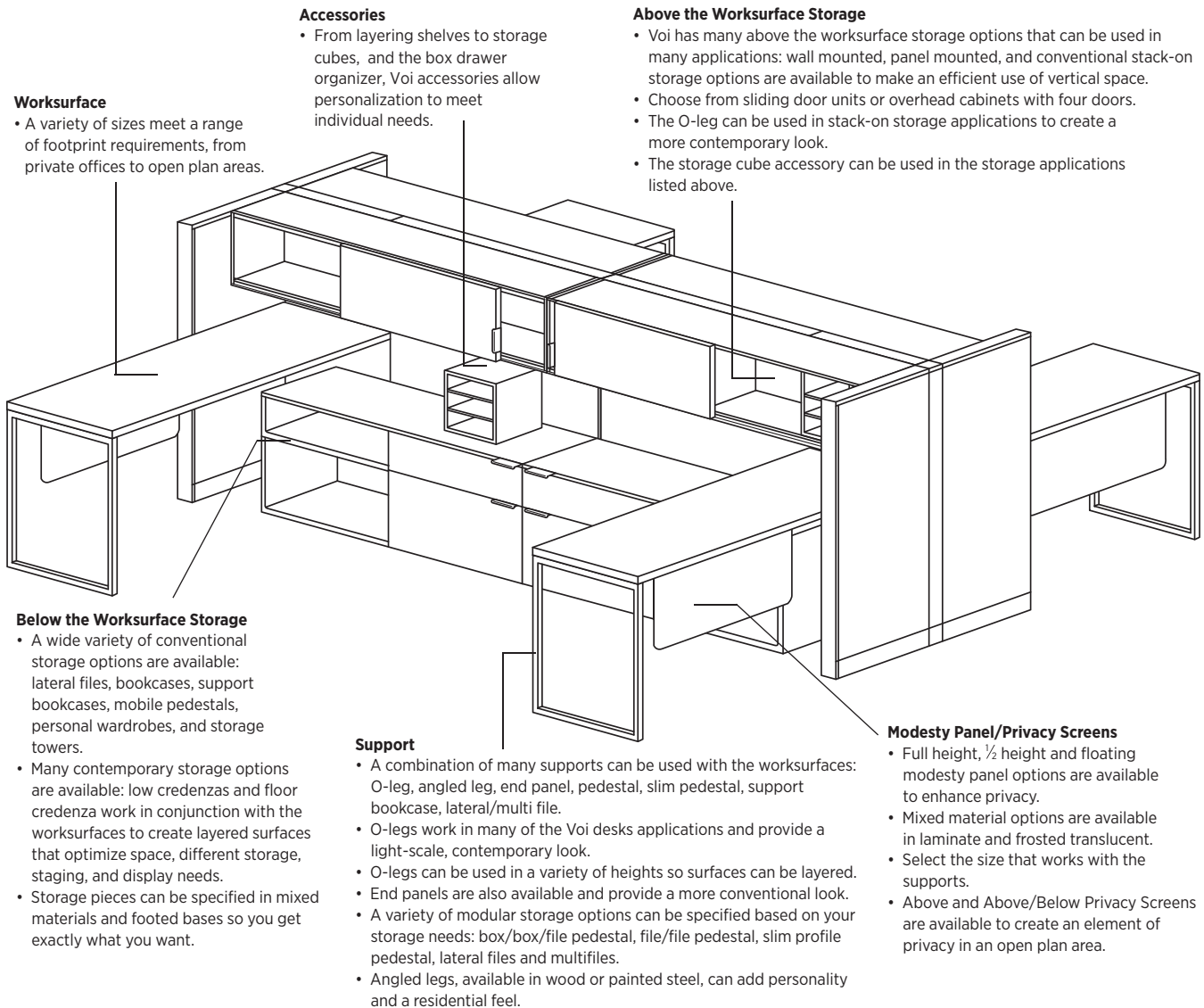

Worksurface

- A variety of sizes meet a range of footprint requirements, from private offices to open plan areas.

Accessories

- From layering shelves to storage cubes, and the box drawer organizer, Voi accessories allow personalization to meet individual needs.

Above the Worksurface Storage

- Voi has many above the worksurface storage options that can be used in many applications: wall mounted, panel mounted, and conventional stack-on storage options are available to make an efficient use of vertical space.
- Choose from sliding door units or overhead cabinets with four doors.
- The O-leg can be used in stack-on storage applications to create a more contemporary look.
- The storage cube accessory can be used in the storage applications listed above.

Below the Worksurface Storage

- A wide variety of conventional storage options are available: lateral files, bookcases, support bookcases, mobile pedestals, personal wardrobes, and storage towers.
- Many contemporary storage options are available: low credenzas and floor credenza work in conjunction with the worksurfaces to create layered surfaces that optimize space, different storage, staging, and display needs.
- Storage pieces can be specified in mixed materials and footed bases so you get exactly what you want.

Support

- A combination of many supports can be used with the worksurfaces: O-leg, angled leg, end panel, pedestal, slim pedestal, support bookcase, lateral/multi file.
- O-legs work in many of the Voi desks applications and provide a light-scale, contemporary look.
- O-legs can be used in a variety of heights so surfaces can be layered.
- End panels are also available and provide a more conventional look.
- A variety of modular storage options can be specified based on your storage needs: box/box/file pedestal, file/file pedestal, slim profile pedestal, lateral files and multifiles.
- Angled legs, available in wood or painted steel, can add personality and a residential feel.

Modesty Panel/Privacy Screens

- Full height, ½ height and floating modesty panel options are available to enhance privacy.
- Mixed material options are available in laminate and frosted translucent.
- Select the size that works with the supports.
- Above and Above/Below Privacy Screens are available to create an element of privacy in an open plan area.

Steps for specification:

1. Select the right worksurface.
Choose the worksurface shape and size that best fits your office layout.

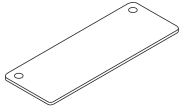

Rectangle Flat Edge Worksurface
Depths: 20", 24", 30", 36"
Widths: 36", 42", 48", 54",
60", 66", 72", 84"

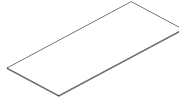

Rectangle Knife Edge Worksurface
Depths: 24", 30"
Widths: 48", 60", 72"

2. Select the supports.
Countless combinations of support options meet a variety of support and storage needs.

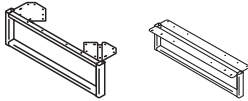

O-Leg and Shared Support for Low Credenza
20"D x 7"H, 24"D x 7"H, 30"D x 7"H
7"H only O-legs attach to worksurface and sit on top of credenzas.

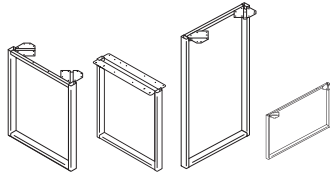

O-Leg and Shared Support for Worksurfaces
20"D x 28½"H, 24"D x 28½"H, 30"D x 28½"H
28½"H, 24"D x 41"H, 30"D x 41"H, 48"D x 28½"H,
60"D x 28½"H O-legs provide support for the worksurface.

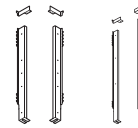

O-Leg-to-Panel Attachment Bracket
Left handed bracket (quantity 1)
Right handed bracket (quantity 1)



Post Leg
28½"H, 2" square

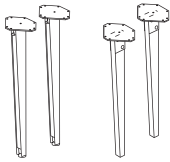

Angled Legs
12"W x 8"D x 32"H, Steel
12"W x 8"D x 32"H, Wood

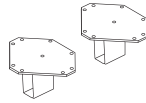

Steel Stanchions
4"H
Stanchions attach to worksurface and sit on top of credenzas.

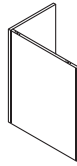

End Panel Support
16"W x 20"D x 28½"H,
16"W x 24"D x 28½"H,
16"W x 30"D x 28½"H

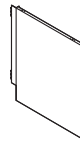

Laminate End Panel Support With Panel Attachment Bracket
24"D x 28½"H, 30"D x 28"H

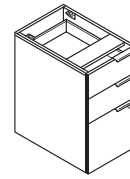

B/B/F Pedestals
16"W x 20"D x 28½"H,
16"W x 24"D x 28½"H,
16"W x 30"D x 28½"H

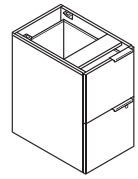

F/F Pedestals
16"W x 20"D x 28½"H,
16"W x 24"D x 28½"H,
16"W x 30"D x 28½"H

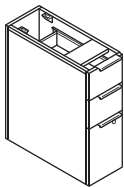

B/B/F Standard Slim Profile Pedestals
9½"W x 24"D x 28½"H,
9½"W x 30"D x 28½"H

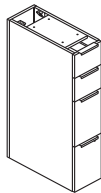

Standing-Height Pedestals
9½"W x 24"D x 41"H,
9½"W x 30"D x 41"H

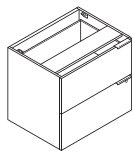

2 Drawer Lateral with Pulls
30"W x 24"D x 28½"H

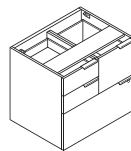

Multi-Drawer Standard File Center
30"W x 24"D x 28½"H

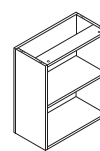

Bookcase Support
30"W x 12"D x 28½"H,
24"W x 12"D x 28½"H

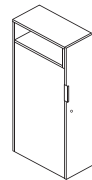

Standing-Height Towers
12"W x 30"D x 50"H,
12"W x 24"D x 50"H

Tips

- When using an O-leg in open plan, panel supported, applications, you must specify an O-leg to panel attachment bracket separately (available in 28"H and 41"H).
- Bookcase Support can only be used exterior facing.
- Telescoping ball-bearing slides used on box and file drawers. Lateral drawers use a progressive ball-bearing slide.
- When specifying a 30"D support on a 36"D worksurface, there will be a 6" overhang.
- All modular pedestals have an easy attach method to the worksurface for quick assembly.
- One double-depth O-leg can replace two regular O-legs in teaming applications.
- Shared O-legs create cleaner aesthetic where two legs are used side-by-side.
- 2" adjustable glides on O-leg supports.
- Standing-Height Support Pedestals bottom two file drawers are locking.
- Standing-Height Bookcase Support contains easy-access, fixed storage shelves.

VOI® SPECIFYING/DESIGN GUIDE

3. Select the modesty panel/privacy screen that works in conjunction with the supports you have specified.

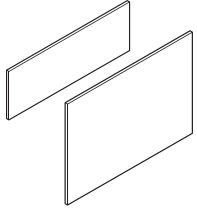

**14" H Full Width/
Half-height
Laminate Modesty
Panel**
28", 34", 40"W
(Modesty Size)
**28" H Full-to-Floor/
Full-Length
Laminate Modesty
Panel**
28", 34", 40"W
(Modesty Size)

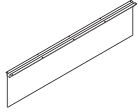

**Laminate Floating
Modesty Panel**
30"W x 14"H, 36"W x
14"H, 42"W x 14"H,
48"W x 14"H, 54"W x
14"H, 60"W x 14"H

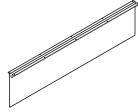

**Mixed Material
Floating Modesty
Panel**
30"W x 14"H, 36"W x
14"H, 42"W x 14"H,
48"W x 14"H, 54"W x
14"H, 60"W x 14"H
Available in Frosted
Translucent only

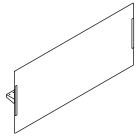

**Above/Below
Privacy Screen**
30"W x 28"H, 36"W
x 28"H, 42"W x 28"H,
48"W x 28"H, 54"W
x 28"H, 60"W x 28"H
Available in Frosted
Translucent only

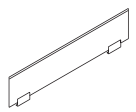

**Above Privacy
Screen**
30"W x 13"H, 36"W x
13"H, 42"W x 13"H,
48"W x 13"H, 54"W x
13"H, 60"W x 13"H
Available in Frosted
Glass only

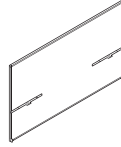

**Above/Below Fabric
Screen**
36"W x 35"H, 42"W
x 35"H, 48"W x 35"H,
54"W x 35"H, 60"W
x 35"H, 66"W x 35"H,
72"W x 35"H

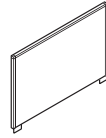

Above Fabric Screen
20"W x 20"H, 20"W
x 13"H, 24"W x 20"H,
24"W x 13"H, 30"W x
20"H, 30"W x 13"H,
36"W x 20"H, 36"W
x 13"H

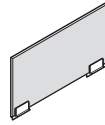

**Above Polymer or
Glass (Side) Screen**
20"W x 13"H, 24"W x
13"H, 30"W x 13"H,
36"W x 13"H

Tips

- Mixed material and laminate floating modesty panels create a lighter scale look by attaching to the top of the worksurface.
- Choose from a variety of materials to create your desired look.
- Laminate modesty panels to create a more conventional look.
- 54"W and 60"W Floating Modesty panels eliminate the need for an external channel.
- Above Privacy Screens provide a division between two worksurfaces and create a division of space in an open plan area.
- Modesty panels cannot be used as a support.
- See modesty panel chart to choose proper modesty size depending on support options.

4. Select Above the Worksurface Storage (Stack-on Storage) or Overhead Cabinets

Select the above the worksurface storage that meets your storage criteria, choose from overhead cabinets, panel mounted storage, conventional or contemporary stack-on storage.

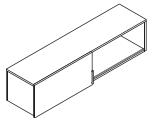

**14 1/4" D x 14" H Shared Overhead
Cabinet with One Sliding Door**
60", 72"

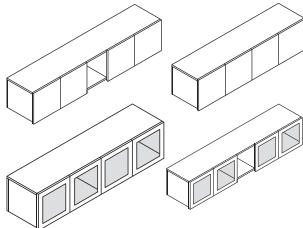

**14 1/4" Overhead Cabinet with 4 Laminate
Doors with or without Cubbie or 4 Frosted
Metal Doors with or without Cubbie**
36", 42", 48" and 60" with 4 Laminate or
Frosted Doors
60", 66" and 72" with Laminate or
Frosted Doors and Cubbie

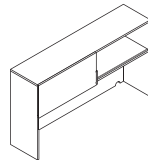

**14 1/4" D x 35" H Stack-on Storage,
Built-up, with Sliding Doors**
72" W only

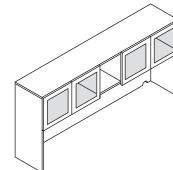

**14 1/4" D x 35" H Stack-on Storage, Built-up,
4 Frosted Metal Doors with Cubbie**
72" W only with Laminate or Frosted Doors
and Cubbie

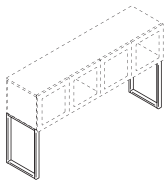

**O-Leg Support for Overhead
Cabinet**
50"-14 1/8" D x 5 1/2" H
65"-14 1/8" D x 20 1/2" H

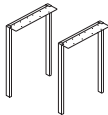

Post Legs for Shared Storage
14" H and 22" H



**Panel Mount Bracket for Shared
Overhead**
Abound and Accelerate

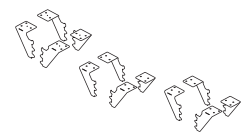

**Panel Mount Bracket for Shared
Overhead**
Abound and Accelerate

Tips

- Select sliding or hinged doors.
- Specify O-leg separately for a contemporary look.
- Optional storage shelf works in conjunction with the O-leg design to provide additional storage space. Only works with 65" H O-legs.
- O-legs come in two sizes to make a 50" H or 65" H stack-on storage unit.
- Wall-mount brackets carry a \$150 upcharge and are specified the model ordering logic.
- Use shared overhead and attachments in small footprint applications.
- Shared overhead must be ordered as left or right to determine open storage location.
- Shared overhead panel mount brackets and overhead post legs allow overhead to span over all panels systems or run down the spine wall, centered on top of the panel.
- Use the 65" H for a more conventional design. 65" H and 50" H aligns with Abound and Accelerate.
- Stack-on Storage must be placed over two full-height supports. Cannot be placed over non-supported sections such as returns using a flat bracket or tower-to-worksurface bracket.
- If the end panel conventional look is preferred, order the built-up stack-on storage models.
- There are two types of for use on Overhead Cabinet and Stack-on Storage.

5. Select the right storage.

Choose from a variety of below the worksurface, as well as traditional, storage options.

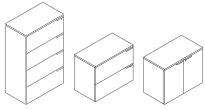

Laterals and Storage Cabinet

2-Drawer Lateral, 4-Drawer Lateral, Storage Cabinet
 36"W x 24"D x 29½"H, 36"W x 20"D x 29½"H,
 36"W x 24"D x 57"H, 36"W x 20"D x 57"H,
 36"W x 24"D x 29½"H, 36"W x 20"D x 29½"H

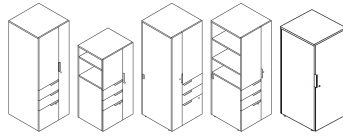

Storage Towers

18"W x 20"D, 18"W x 24"D, 24"W x 20"D, 24"W x 24"D, 50"H and 65"H
Storage Tower, One Door
 18"W x 20"D x 42"H
 Available in Footed Option

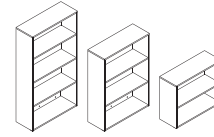

Bookshelves

36"W x 13"D x 29½"H (2 Shelf)
 36"W x 13"D x 50"H (3 Shelf)
 36"W x 13"D x 65"H (4 Shelf)

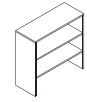

Bookcase Hutch without Doors

36"W x 14"D x 35"H

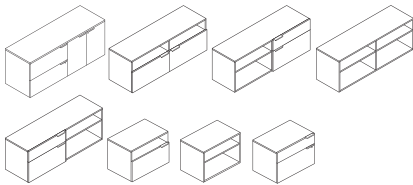

Credenzas

Credenza: 24"D x 72"W x 29½"H
 Low Credenzas: 20"D x 21½"H x 30", 36", 60", 72"W
 Low Credenzas with a variety of door/drawer options
 Limited dimensions available in Footed Option

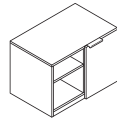

Mobile Credenza

30"W x 20"D x 21½"H

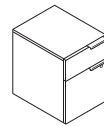

Mobile Pedestal

15¾"W x 20¼"D x 21¼"H
 Available in Footed Option

Tips

- Small credenza models can be used in small footprint applications.
- Can use pedestal or credenza seat cushions on smaller credenza models.
- Low credenzas work in conjunction with worksurface 7" O-leg designed to create a unique layering design.
- Bookcase/laterals and other conventional storage components provide additional storage space.
- Must specify chassis and drawer front color separately.
- Low Credenzas, Laterals and Mobile Pedestals have seat cushions to create additional seating in the workspace.
- Storage and Personal Tower models offer conventional storage as well as wardrobes with a coat rod.
- A worksurface-to-tower bracket kit allows the attachment of worksurfaces to Storage and Personal Tower models.
- Telescoping ball-bearing slides used on box and file drawers. Lateral drawers use a progressive ball-bearing slide.

6. Select Accessories to add color, additional storage and organization to your workspace.

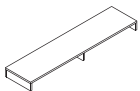

Layering Shelf

60"W x 14¼"D x 5½"H
 72"W x 14¼"D x 5½"H

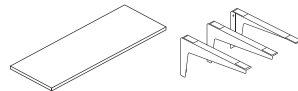

Shelves and Shelf Brackets

Shelf Depth: 13"
 Shelf Widths: 30", 36", 45"
 Bracket sold separately, set of three

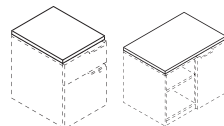

Seat Cushion for Credenzas and Mobile Credenza/Pedestal

Pedestal Cushion
 15⅞"W x 20"D x 2"H
Credenza Cushion
 20"W x 30"D x 2"H, 20"W x 36"D x 2"H

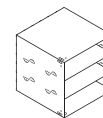

Metal Storage Cube

12" x 12"

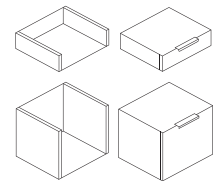

Laminate Storage Cubes

15"W x 13"D x 4"H
 15"W x 13"D x 12"H

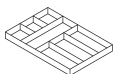

Drawer Organizer

12"W x 14½"D x 1½"H

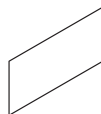

for Shared Overhead

30"W x 15"D for use with 60"W Shared Overhead
 36"W x 15"D for use with 72"W Shared Overhead

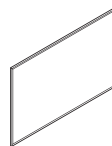

48"W x 31"H

LED Task Light

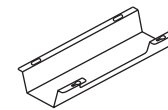

Cable Management Trough

17"W

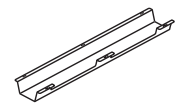

Cable Management Trough

36"W

Tips

- Choose from many bright Storage Cube colors for a colorful design element while providing additional storage.
- Use the Drawer Organizer to keep small items in order. Also offered in the same bright Storage Cube colors.
- Layering shelves are great for filing and piling or in conjunction with the lower credenza.
- Optimize shared overhead capabilities by adding the for Shared Overhead.

VOI® SPECIFYING/DESIGN GUIDE

VOI® AND SYSTEMS INTEGRATION

Worksurface Applications

Either Voi or Systems worksurfaces can be used with Voi in an open plan application. There are several support options:

- A. Completely panel supported.
- B. Combination of panel supported and another worksurface support such as:
 - Bookcase support
 - Pedestal (Brigade®, Flagship®, Contain®, or Voi®)
 - Systems open leg
 - Voi O-leg
 - End panel (Systems or Voi)
 - Tower to worksurface bracket
 - Support column
 - Systems round post leg
 - Voi post leg
- C. Freestanding:
 - Bookcase support
 - Two pedestals (Brigade®, Flagship®, Contain®, or Voi®)
 - Two Voi O-legs
 - One Voi O-leg and one Voi O-leg support for lower credenzas
 - Two end panels (metal or Voi)—requires metal or Voi modesty panel
 - Four (Two 2-Pack) Voi angled legs, wood or steel
 - Two Voi angled legs, steel and two Voi steel stanchion supports for low credenzas

Additional application guidelines for worksurfaces:

- Systems worksurfaces are available with grommets or no grommets.
- When Voi lower credenzas are used along the spine wall and are placed adjacent to the wing wall, one electrical/data cutout on the wing wall will be blocked.
- When Voi credenzas are used along the wing wall and are placed adjacent to the spine wall, one electrical/data cutout on the spine wall will be blocked.
- When the Voi O-leg support for credenzas is used, it is recommended to also panel attach the worksurface with the worksurface anti-dislodgement bracket kit HWSA2.
- When the Voi O-leg support is used with panels, it is recommended to also panel attach the O-leg to the panel with the O-leg to panel bracket kit HLSPBL (left) and/or HLSPBR (right). This bracket will provide additional workstation rigidity.
- When the Voi end panel support is used with panels, it is recommended to use the end panel support with panel bracket model. This model will provide additional workstation rigidity.
- The worksurface to tower bracket kit, HSTB2W1, will work with Voi towers, Voi worksurfaces, and systems worksurfaces.
- Knife Edge surfaces are recommended to only use angled post legs as supports.
- Knife Edge worksurfaces are intended to be stand-alone. Surface gaps may occur if connecting to a panel or using return worksurfaces.

Application Guidelines—Combination of Panel Supported and Another Worksurface Support

- For applications where 1) the worksurface is perpendicular to the spine wall; 2) the worksurface is panel supported off the spine wall; and 3) there are Voi credenzas placed under the worksurface along the spine: there is not enough clearance to use standard worksurface cantilevers to attach the worksurface to the spine. Use the worksurface anti-dislodgement bracket kit HWSA2 to panel attach the worksurface in lieu of cantilevers.

Panel Mounted Stack-on Storage Applications

- The Voi stack-on storage cabinets can be used on Abound and Accelerate as panel mounted overheads.
- The sliding door stack-on storage units are available in 36", 42", 48" widths in addition to 60", 66", and 72" widths.
- The 4 door stack-on storage units are only available in 36", 42", 48", 60", 66", and 72" widths.
- The storage units require a storage to panel bracket kit, model HLSPMB. This model includes one left hand, one right hand, and one center bracket. The brackets are available in all P1 and P2 paint colors.
- The storage cabinets do not have off modular capabilities.
- For proper installation and support, the storage units must follow the following specification rules:
 - There should be a storage unit of the same construction on each side of a given panel.
 - The storage units on opposite sides of a given panel should be in the same location vertically and horizontally.
 - Only one storage unit per panel, per side.
 - The wing panel adjacent to the spine wall needs to be the same height as the spine wall.

Contact HON's Integrated Design Services team with specification questions.



Laminate Worksurfaces — Rectangle

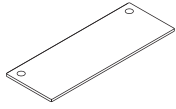

DESCRIPTION	MODEL	SHIP WEIGHT	CUBE	LIST PRICE BY LAMINATE GRADE	
				L1	L2
Rectangle Worksurfaces					
36"W x 20"D	HLSLR2036	40	2.2	\$236	\$246
42"W x 20"D	HLSLR2042	46	2.6	\$262	\$272
48"W x 20"D	HLSLR2048	52	2.9	\$282	\$292
54"W x 20"D	HLSLR2054	64	3.5	\$316	\$331
60"W x 20"D	HLSLR2060	70	3.5	\$348	\$363
66"W x 20"D	HLSLR2066	76	4.2	\$378	\$393
72"W x 20"D	HLSLR2072	82	4.2	\$392	\$407
36"W x 24"D	HLSLR2436	47	2.6	\$247	\$262
42"W x 24"D	HLSLR2442	54	3.0	\$277	\$292
48"W x 24"D	HLSLR2448	61	3.4	\$300	\$315
54"W x 24"D	HLSLR2454	68	4.2	\$323	\$343
60"W x 24"D	HLSLR2460	75	4.2	\$351	\$371
66"W x 24"D	HLSLR2466	82	5.0	\$380	\$400
72"W x 24"D	HLSLR2472	89	5.0	\$394	\$414
84"W x 24"D	HLSLR2484	103	5.7	\$580	\$605

NOTES:

- Systems worksurfaces can be used with all Voi components.
- Worksurfaces are abrasion- and stain-resistant laminate over durable 1/8" solid core high performance particleboard: resists wrapping.
- There is one 3" grommet in 36"W and 42"W worksurfaces and two in 48"W-84"W worksurfaces.
- One flat bracket ships with each worksurface.
- When attaching tops to panels, refer to Systems section of this pricer.
- Square edge detail.
- When using a floating modesty panel or an external channel under the worksurface, the depth clearance for keyboard trays and center drawers decreases by 8". See accessory matrix in accessory section of the pricer.
- 3" Power Hub model HGRMTAC can be interchanged with 3" standard grommet.
- ! Voi® worksurfaces cannot be used with Abode™ Desks components.
- ! Grommets in worksurfaces must be specified. If grommets are specified, grommets come in predetermined location.
- ! Edgeband option only on all Voi worksurfaces. For edgeband options, see matrix on page 171.
- ! When specifying an 84" Worksurface, cannot use two O-legs, must use at least one additional support such as a pedestal or lateral file.
- ! When using a worksurface as a bridge, no additional supports are needed. One support is required for returns, two supports are required for desks and credenzas.
- ! Lateral file or multi files must be used with surfaces 24"D and 60"W or greater.
- ! Depending on your support combination, an external channel may be required for extra support on unsupported spans greater than 54"W. Please see the matrix on page 190 for more details.
- ! If using a 54"W or 60"W floating modesty, it is not necessary to spec an external channel.
- ! When attaching worksurfaces to panels, one or more of the following are required: anti-dislodgement brackets, end panel, support leg and/or cantilevers. Cantilevers and anti-dislodgement brackets must be ordered separately when attaching worksurfaces to panels.
- ! A return worksurface is considered 48"W or shorter. Longer returns cannot be supported by a flat bracket only.

HOW TO SPECIFY

<p>Select Model Number</p> <p>HLSLR2036</p>	<p>Select Worksurface Laminate and Edge Color</p> <p>See page 171</p> <p>NN</p>	<p>Select Grommet Option and Color</p> <p>X No Grommet If choosing the grommet option G Grommet Select Grommet Color See page 171</p> <p>GT5</p>
--	--	--

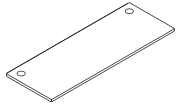

DESCRIPTION	MODEL	SHIP WEIGHT	CUBE	LIST PRICE BY LAMINATE GRADE	
				L1	L2
Rectangle Worksurfaces					
36"W x 30"D	HLSLR3036	58	3.2	\$282	\$297
42"W x 30"D	HLSLR3042	67	3.7	\$305	\$320
48"W x 30"D	HLSLR3048	75	4.2	\$323	\$338
54"W x 30"D	HLSLR3054	84	5.1	\$360	\$380
60"W x 30"D	HLSLR3060	92	5.1	\$402	\$422
66"W x 30"D	HLSLR3066	101	6.1	\$432	\$452
72"W x 30"D	HLSLR3072	110	6.1	\$469	\$489
84"W x 30"D	HLSLR3084	127	7.0	\$641	\$666
60"W x 36"D	HLSLR3660	110	6.1	\$503	\$528
66"W x 36"D	HLSLR3666	120	7.2	\$544	\$569
72"W x 36"D	HLSLR3672	130	7.2	\$611	\$636

NOTES:

- Systems worksurfaces can be used with all Voi components.
- Worksurfaces are abrasion- and stain-resistant laminate over durable 1/8" solid core high performance particleboard; resists wrapping.
- There is one 3" grommet in 36"W and 42"W worksurfaces and two in 48"W-84"W worksurfaces.
- One flat bracket ships with each worksurface.
- When attaching tops to panels, refer to Systems section of this pricer.
- Square edge detail.
- When using a floating modesty panel or an external channel under the worksurface, the depth clearance for keyboard trays and center drawers decreases by 8". See accessory matrix in accessory section of the pricer.
- 3" Power Hub model HGRMTAC can be interchanged with 3" standard grommet.
- ! Voi® worksurfaces cannot be used with Abode™ Desks components.
- ! Grommets in worksurfaces must be specified. If grommets are specified, grommets come in predetermined location.
- ! Edgeband option only on all Voi worksurfaces.
- ! When specifying an 84" Worksurface, cannot use two O-legs, must use at least one additional support such as a pedestal or lateral file.
- ! When using a worksurface as a bridge, no additional supports are needed. One support is required for returns, two supports are required for desks and credenzas.
- ! Lateral file or multi files must be used with surfaces 24"D and 60"W or greater.
- ! Depending on your support combination, an external channel may be required for extra support on unsupported spans greater than 54"W. Please see page 190 for models and a matrix to aid in specifying.
- ! If using a 54"W or 60"W floating modesty, it is not necessary to spec an external channel.
- ! When attaching worksurfaces to panels, one or more of the following are required: anti-dislodgement brackets, end panel, support leg and/or cantilevers. Cantilevers and anti-dislodgement brackets must be ordered separately when attaching worksurfaces to panels.
- ! A return worksurface is considered 48"W or shorter. Longer returns cannot be supported by a flat bracket only.

HOW TO SPECIFY**Select Model Number**

HLSLR3036

Select Worksurface Laminate and Edge Color

See page 171

NN

Select Grommet Option and Color

X No Grommet If choosing the grommet option
G Grommet Select Grommet Color
 See page 171

GT5

Laminate Worksurfaces — Rectangle

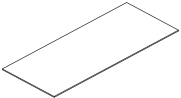
	DESCRIPTION	MODEL	SHIP WEIGHT	CUBE	LIST PRICE BY LAMINATE GRADE	
					L1	L2
	Rectangle Worksurfaces Top with Knife Edge					
	48"W x 24"D	HLSLR2448J	54	3.4	\$412	\$427
	60"W x 24"D	HLSLR2460J	75	4.2	\$480	\$500
	72"W x 24"D	HLSLR2472J	89	5.0	\$539	\$559
	48"W x 30"D	HLSLR3048J	75	4.2	\$443	\$458
	60"W x 30"D	HLSLR3060J	92	5.1	\$550	\$570
	72"W x 30"D	HLSLR3072J	110	6.1	\$644	\$664

NOTES:

- Systems worksurfaces can be used with all Voi® components.
- Worksurfaces are abrasion- and stain-resistant laminate over durable 1½" solid core high performance particleboard: resists wrapping.
- There are two 3" grommets in Knife Edge worksurfaces, if specified.
- When using a floating modesty panel or an external channel under the worksurface, the depth clearance for keyboard trays and center drawers decreases by 8". See accessory matrix in accessory section of the pricer.
- 3" Power Hub model HGRMTAC can be interchanged with 3" standard grommet.
- ❗ Voi® worksurfaces cannot be used with Abode™ Desks components.
- ❗ Grommets in worksurfaces must be specified. If grommets are specified, grommets come in predetermined location.
- ❗ Depending on your support combination, an external channel may be required for extra support on unsupported spans greater than 54"W. Please see the matrix on page 190 for more details.
- ❗ If using a 54"W or 60"W floating modesty, it is not necessary to spec an external channel.
- ❗ Voi® Knife Edge surfaces are recommended to only use angled post legs as supports.
- ❗ Knife Edge worksurfaces are intended to be stand-alone. Surface gaps may occur if connecting to a panel or using return worksurfaces.

HOW TO SPECIFY

<p>Select Model Number</p> <p>HLSLR2448J .</p>	<p>Select Worksurface Laminate and Edge Color</p> <p>See page 171</p> <p>NN .</p>	<p>Select Grommet Option and Color</p> <p>X No Grommet G Grommet</p> <p>If choosing the grommet option, select Grommet Color. See page 171.</p> <p>GT1</p>
---	--	---

VOI® Worksurface Supports

GSA SIN 33721



Icon Legend on page 19

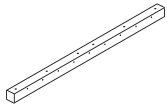

DESCRIPTION

External Support Channel
 42"W for a 54" Worksurface
 48"W for a 60" Worksurface
 54"W for a 66" Worksurface
 60"W for a 72" Worksurface
 72"W for an 84" Worksurface

MODEL

SHIP WEIGHT

CUBE

LIST PRICE

HLSLZ5SC54	5	0.5	\$93
HLSLZ5SC60	6	0.5	\$98
HLSLZ5SC66	7	0.5	\$101
HLSLZ5SC72	7	0.5	\$110
HLSLZ5SC84	12	0.7	\$110

- ! Available in Graphite paint only.
- ! When specifying panel-hung worksurfaces, specify external channel as if supported by two O-legs via selection chart.
- ! When specifying a 54"W or 60"W Floating Modesty Panel, it is not necessary to specify an external channel.

EXTERNAL CHANNEL SELECTION GUIDE

Support Combination		Worksurface Width for Rectangle, Wedge, and Saddle				
Support 1	Support 2	84 in	72 in	66 in	60 in	54 in
O-Leg	O-Leg	NA	HLSLZ5SC72	HLSLZ5SC66	HLSLZ5SC60	HLSLZ5SC54
O-Leg	Slim Profile Pedestal	HLSLZ5SC84	HLSLZ5SC66	HLSLZ5SC60	HLSLZ5SC54	NA
O-Leg	Bookcase	HLSLZ5SC72	HLSLZ5SC66	HLSLZ5SC60	HLSLZ5SC54	NA
O-Leg	Pedestal	HLSLZ5SC72	HLSLZ5SC60	HLSLZ5SC54	NA	NA
O-Leg	End-Panel	HLSLZ5SC84	HLSLZ5SC60	HLSLZ5SC54	NA	NA
Slim Profile Pedestal	Slim Profile Pedestal	HLSLZ5SC72	HLSLZ5SC60	HLSLZ5SC54	NA	NA
Slim Profile Pedestal	Bookcase	HLSLZ5SC72	HLSLZ5SC60	HLSLZ5SC54	NA	NA
Slim Profile Pedestal	Pedestal	HLSLZ5SC66	HLSLZ5SC54	NA	NA	NA
Slim Profile Pedestal	End-Panel	HLSLZ5SC66	HLSLZ5SC54	NA	NA	NA
Pedestal	Bookcase	HLSLZ5SC66	HLSLZ5SC54	NA	NA	NA
End-Panel	Bookcase	HLSLZ5SC66	HLSLZ5SC54	NA	NA	NA
Bookcase	Bookcase	HLSLZ5SC66	HLSLZ5SC54	NA	NA	NA
End-Panel	End-Panel	HLSLZ5SC60	NA	NA	NA	NA
Pedestal	Pedestal	HLSLZ5SC60	NA	NA	NA	NA
Pedestal	End-Panel	HLSLZ5SC60	NA	NA	NA	NA
O-Leg	Lateral/Multifile	HLSLZ5SC54	NA	NA	NA	NA
Bookcase	Lateral/Multifile	NA	NA	NA	NA	NA
Slim Profile Pedestal	Lateral/Multifile	NA	NA	NA	NA	NA
Pedestal	Lateral/Multifile	NA	NA	NA	NA	NA
End-Panel	Lateral/Multifile	NA	NA	NA	NA	NA

*All Rudder worksurfaces use external channel model HLSLZ5SC60.

HOW TO SPECIFY

<p>Select Model Number</p> <p>H L S L Z 5 S C 8 4 . P</p>	<p>Select Paint Color</p> <p>See page 171</p>
--	--

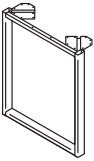
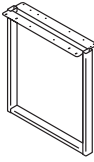
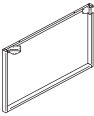
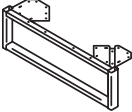
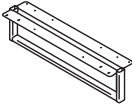

	DESCRIPTION	MODEL	SHIP WEIGHT	CUBE	LIST PRICE BY PAINT GRADE		
					P1	P2	P3
	O-Leg Support for Worksurfaces						
	20"D x 28½"H	HLSL2028O	15	3.7	\$292	\$296	\$312
	24"D x 28½"H	HLSL2428O	17	3.7	\$316	\$320	\$336
	30"D x 28½"H	HLSL3028O	19	5.4	\$352	\$356	\$372
	NOTES: Ship fully assembled, 1/pack. Non-handed.						
	! Specify paint only.						
	SPECIFYING EXAMPLE: HLSL2028O.T1						
	O-Leg Shared Support for Worksurfaces						
	20"D x 28½"H	HLSL2028SL	15	3.7	\$349	\$353	\$369
	24"D x 28½"H	HLSL2428SL	17	3.7	\$394	\$398	\$414
	30"D x 28½"H	HLSL3028SL	19	5.4	\$438	\$442	\$458
	NOTES: Ship fully assembled, 1/pack. Non-handed.						
	! Specify paint only.						
	SPECIFYING EXAMPLE: HLSL2028SL.T1						
	Double-Depth O-Leg Support for Worksurfaces						
	48"D x 28½"H	HLSL4828O	18	7.0	\$597	\$605	\$617
	60"D x 28½"H	HLSL6028O	19	8.7	\$665	\$673	\$685
	NOTES: Ship fully assembled, 1/package. Non-handed.						
	O-Leg Support for Low Credenzas						
	20"D x 7"H	HLSL207O	5	1.0	\$197	\$201	\$217
	24"D x 7"H	HLSL247O	6	1.0	\$213	\$217	\$233
	30"D x 7"H	HLSL307O	7	1.0	\$271	\$275	\$291
	NOTES: Ship fully assembled, 1/pack. Non-handed.						
	! Specify paint only.						
	SPECIFYING EXAMPLE: HLSL207O.T1						
	O-Leg Shared Support for Low Credenzas						
	20"D x 7"H	HLSL207SL	5	1.0	\$245	\$249	\$265
	24"D x 7"H	HLSL247SL	6	1.0	\$266	\$270	\$286
	30"D x 7"H	HLSL307SL	7	1.0	\$337	\$341	\$357
	NOTES: Ship fully assembled, 1/pack. Non-handed.						
	! Specify paint only.						
	SPECIFYING EXAMPLE: HLSL207SL.T1						

NOTES:

- A variety of pedestals, end panels, and O-legs can be combined to create a conventional or contemporary desk.
- O-leg ships fully assembled with mounting hardware.
- Shared O-Legs create a cleaner aesthetic in all applications where two legs are used side-by-side.
- Shared O-Leg bracket will span both worksurfaces to provide the same support with the look of a single O-leg.
- Will have a 6" overhang when using 30" worksurface supports with a 36"D worksurface.
- Glides on O-Leg Support for Worksurfaces and Post Leg Base have 2" of adjustability. No glides on 7"H O-leg. Glides on end panels have 1¼" adjustability.

! O-legs may only be attached to worksurfaces, not storage units.

HOW TO SPECIFY

<p>Select Model Number</p> <p>H L S L 2 0 2 8 O . T 1</p>	<p>Select Paint Color</p> <p>See page 171</p> <p>T 1</p>
--	---

VOI® Worksurface Supports

GSA SIN 33721

Icon Legend on page 19

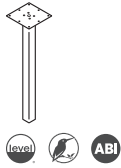

DESCRIPTION

Post Leg Base
28½”H x 2” square

MODEL

HLSL28P

SHIP WEIGHT

15

CUBE

1.0

LIST PRICE BY PAINT GRADE

P1

\$292

P2

\$296

P3

\$312

- ! Post leg cannot be used on primary worksurface with an O-leg as the other support.
- ! Post leg can only be used to support peninsula, not as primary supports for a top.

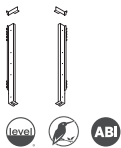

28½”H O-Leg-to-Panel Attachment Bracket

28½”H Left handed bracket (quantity 1)
28½”H Right handed bracket (quantity 1)

HLSLPBL

3 ☹

0.4

\$100

\$104

N/A

HLSLPBR

3 ☹

0.4

\$100

\$104

N/A

NOTES: Used to connect Voi O-Leg to a systems panel for additional workstation rigidity. Bracket designed to work with edgeband worksurfaces only. Brackets are handed, come one per package and include self-tapping screws. Specify paint.

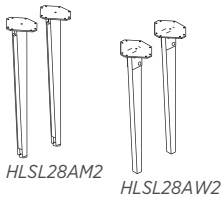

Angled Legs

12”W x 8”D x 32”H Steel — 2-Pack
12”W x 8”D x 32”H Wood — 2-Pack

HLSL28AM2

15 ☹

1.3

\$323

\$331

\$343

HLSL28AW2

14 ☹

1.5

\$420

NOTES: Angled Steel Legs come equipped with a removable wire management channel in each leg.

- ! 4”H Stanchions to be used on floor storage with feet ONLY.
- ! O-Leg Support to be used on floor storage without feet ONLY.
- ! Wood legs use natural wood material. The color on each leg may contain natural variation.
- ! Pricing shown is per carton. Ordering 2 of either model will result in 2 cartons being shipped, giving you 4 legs.

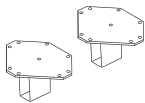

Steel Stanchions — 2-Pack

4”H

HLSL4AM2

5 ☹

0.2

\$151

\$159

\$171

- ! 4”H Stanchions to be used on floor storage with feet ONLY.
- ! O-Leg Support to be used on floor storage without feet ONLY.
- ! Wood legs use natural wood material. The color on each leg may contain natural variation.
- ! Pricing shown is per carton. Ordering 2 of either model will result in 2 cartons being shipped, giving you 4 legs.

DESCRIPTION	MODEL	SHIP WEIGHT	CUBE	LIST PRICE BY LAMINATE GRADE	
				L1	L2
End Panel Support 16”W x 20”D x 28½”H 16”W x 24”D x 28½”H 16”W x 30”D x 28½”H NOTES: Ship in two pieces.	HLSL2028E	39	3.2	\$188	\$198
	HLSL2428E	44	3.7	\$203	\$213
	HLSL3028E	50	4.2	\$216	\$226

NOTES:

- A variety of pedestals, end panels, and O-legs can be combined to create a conventional or contemporary desk.
- Voi® square support column is interchangeable with the Systems worksurface round support column: HCNLEG29.
- Glides on Post Leg Base have 2” of adjustability. Glides on end panels have 1¼” adjustability.

HOW TO SPECIFY

Select Model Number

H L S L 2 0 2 8 E . H

Select Laminate/Paint

See page 171



Icon Legend on page 19

Standing-Height Worksurface Supports

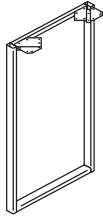

DESCRIPTION

Standing-Height O-Leg Support for Worksurfaces

24"D x 41"H
30"D x 41"H

MODEL

HLSL2441O
HLSL3041O

SHIP WEIGHT CUBE

16 5.3
17 6.5

LIST PRICE BY PAINT GRADE

P1 P2 P3

\$424 \$430 \$444
\$474 \$480 \$494

NOTES: Ship fully assembled, 1/package. Non-handed.

Coordinate™ Power Modules will work with standing-height applications for 10500™ and Voi® desks. Please see Coordinate™ Accessories Stand-Alone Pricer pages for more information.

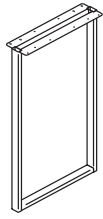

Standing-Height O-Leg Shared Support for Worksurfaces

24"D x 41"H
30"D x 41"H

HLSL2441SL
HLSL3041SL

16 5.3
17 6.5

\$478 \$484 \$498
\$529 \$535 \$549

NOTES: Ship fully assembled, 1/package. Non-handed.

Coordinate™ Power Modules will work with standing-height applications for 10500™ and Voi® desks. Please see Coordinate™ Accessories Stand-Alone Pricer pages for more information.



Standing-Height O-Leg to Panel Attachment Bracket

41"H Left-hand Bracket
41"H Right-hand Bracket

HLSLSPBL
HLSLSPBR

6 1.0
6 1.0

\$127 \$131 N/A
\$127 \$131 N/A

NOTES: 1/package. Brackets are handed as shown above. To be used with 41"H O-legs shown above (HLSL2441O and HLSL3041O).

NOTES:

- O-leg glides have 2" adjustability.
- O-Leg to Panel Attachment Brackets are used to connect Voi® O-Legs to a systems panel for additional worksurface rigidity.

! O-legs may only be attached to worksurfaces, not storage units.

HOW TO SPECIFY

Select Model Number	Select Paint Color
	See page 171
H L S L 2 4 4 1 O	T 1

VOI® Standing-Height Laminate Support

GSA SIN 33721



Icon Legend on page 19

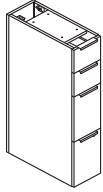

DESCRIPTION	MODEL	SHIP WEIGHT	CUBE	L1 LIST	L2 UPCHARGES	
					CHASSIS	FRONTS
Standing-Height Support Pedestals — Box/Box/File/File						
9½"W x 24"D x 41"H	HL2441S	94	11.9	\$1480	\$40	\$20
9½"W x 30"D x 41"H	HL3041S	113	14.7	\$1538	\$45	\$20
NOTES: Top two drawers are non-locking.						
! Cannot use grommet worksurfaces with Standing-Height Support Storage.						

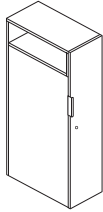

DESCRIPTION	MODEL	SHIP WEIGHT	CUBE	L1 LIST	L2 UPCHARGES	
					CHASSIS	FRONTS
Standing-Height Side Access Storage Tower						
12"W x 24"D x 50"H - Left	HL2450L	100	11.0	\$1349	\$35	\$20
12"W x 24"D x 50"H - Right	HL2450R	100	11.0	\$1349	\$35	\$20
12"W x 30"D x 50"H - Left	HL3050L	121	13.6	\$1406	\$35	\$20
12"W x 30"D x 50"H - Right	HL3050R	121	13.6	\$1406	\$35	\$20

NOTES:

- Tower includes coat hook on back of door.
- Chassis and drawer front panels can be specified separately.
- Tower door is locking. Ships with one handle.
- Support Pedestals bottom file drawers will lock, top box drawers will not.
- Standing-Height Pedestals will have 6" overhang when using 30"D support storage with a 36"D worksurface.
- Use the worksurface to tower bracket kit model HSTB2W1 on page 218 to attach worksurfaces to the Storage Tower models.

- ! Pedestals ship fully assembled but must attach to a worksurface with a quick release bracket, provided. Pedestals are non-handed and are interchangeable.
- ! Locking units equipped with HON "One Key" interchangeable core removable locks. Keyed alike core must be ordered separately.

HOW TO SPECIFY

Select Model Number HL2441S	Select Chassis Laminate See page 171 N	Select Drawer Front Laminate See page 171 N	Select Pull Color See page 171 T4
---------------------------------------	---	--	--



Coordinate™ Sit-to-Stand Worksurface Supports

	DESCRIPTION	MODEL	SHIP WEIGHT	CUBE	LIST PRICE BY LAMINATE GRADE	
					L1	L2
	Rectangle Worksurfaces					
	48"W x 24"D	HLSLR2448	61	3.4	\$300	\$315
	54"W x 24"D	HLSLR2454	68	4.2	\$323	\$343
	60"W x 24"D	HLSLR2460	75	4.2	\$351	\$371
	66"W x 24"D	HLSLR2466	82	5.0	\$380	\$400
	72"W x 24"D	HLSLR2472	89	5.0	\$394	\$414
	Rectangle Worksurfaces					
	48"W x 30"D	HLSLR3048	75	4.2	\$323	\$338
	54"W x 30"D	HLSLR3054	84	5.1	\$360	\$380
	60"W x 30"D	HLSLR3060	92	5.1	\$402	\$422
	66"W x 30"D	HLSLR3066	101	6.1	\$432	\$452
	72"W x 30"D	HLSLR3072	110	6.1	\$469	\$489

HOW TO SPECIFY

<p>Select Model Number</p> <p>HLSLR2448</p>	<p>Select Worksurface Laminate and Edge Color</p> <p>See page 171</p> <p>NN</p>	<p>Select Grommet Option and Color</p> <p>X No Grommet If choosing the grommet option G Grommet Select Grommet Color See page 171</p> <p>GT5</p>
--	--	---

VOI® Height Adjustable Bases

OPEN MARKET



Icon Legend on page 19

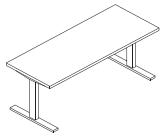

Base shown with work surface attached.

DESCRIPTION**MODEL****SHIP WEIGHT****CUBE****LIST PRICE****Coordinate™ Height Adjustable Base – 2 Stage**

24"D Feet and Worksurface Brackets

HHAB2S2L

63

2.4

\$1006

NOTES: Base is a dual motor 2-stage design with standard anti-collision. Legs raise from 25⁵/₈" to 45¹/₄". Base telescopes to accommodate any rectangular work surface between 24"D x 48"W and 30"D x 72"W. Supports weight capacity of 250 lbs. (excluding work surface weight). See page 718 for Voi® Worksurfaces. See page 718 for Systems Worksurfaces. For Height Adjustable Base Accessories see page 716. Foundation™, Systems, Voi®, 10500, and Preside® all have work surfaces within this range.

⚠ When attaching a Keyboard Tray, remember to also specify a Keyboard Spacer Kit (HKBS).

⚠ Telescoping horizontal frame will extend just over 2" from underside of the work surface.

SPECIFYING EXAMPLE: HHAB2S2L.P8L

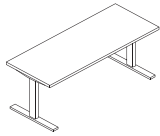

Base shown with work surface attached.

Coordinate™ Height Adjustable Base – 3 Stage

24"D Feet and Worksurface Brackets

HHAB3S2L

67

2.4

\$1120

NOTES: Base telescopes to accommodate any rectangular work surface between 24"D x 48"W and 30"D x 72"W. Supports weight capacity of 250 lbs. (excluding work surface weight). Foundation™, Systems, Voi®, 10500, and Preside® all have work surfaces within this range. Base is a dual motor 3-stage design with standard anti-collision. Legs raise from 21⁵/₈" to 47³/₄".

⚠ Telescoping horizontal frame will extend just over 2" from underside of the work surface.

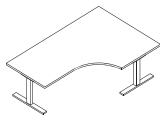

Base shown with work surface attached.

Coordinate™ 3-Leg Height Adjustable Base – 3 Stage

24"D Feet and Worksurface Brackets

HHAB3S3L

91

3.6

\$1896

NOTES: Base is a three motor 3-stage design with standard anti-collision. Legs raise from 21⁵/₈" to 47³/₄". **The 3-leg base supports corner coves or two-piece work surfaces 41"-72"W x 35"-72"L x 23¹/₄"-30"D. 48"W 120 degree corner work surfaces are also supported. When using two work surfaces, the connection between the two must be over the telescoping frame. Supports weight capacity of 375 lbs.** (excluding work surface weight). Can be used with 48" 120 degree and work surface models.

⚠ When using two work surfaces, a flat bracket is required. Bracket purchased separately — HHN831124, HHN831130 — see page 589.

⚠ Telescoping horizontal frame will extend just over 2" from underside of the work surface.

NOTES:**Coordinate™ Height Adjustable Bases**

- Comes standard with one-touch, four memory controller with digital display; no specification needed, available in black finish only.
- **HON 5-Year Limited Warranty.**

⚠ Coordinate™ Height Adjustable Bases not compatible with 36"D rectangular work surfaces.

HOW TO SPECIFY**Select Model Number****Select Finish**

P71 Black
P8L Nickel
PD8 White

H H A B 2 S 2 L .

P 8 L

Laminate Support/Support Pedestals

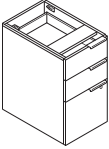
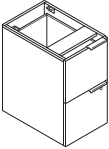
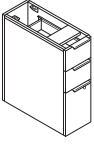
	DESCRIPTION	MODEL	SHIP WEIGHT	CUBE	L1 LIST	L2 UPCHARGES	
						CHASSIS	FRONTS
	Support Pedestals — Box/Box/File						
	16"W x 20"D x 28½"H	HLSL2028B	73	7.3	\$689	\$15	\$10
	16"W x 24"D x 28½"H	HLSL2428B	85	8.5	\$762	\$20	\$10
	16"W x 30"D x 28½"H	HLSL3028B	105	10.5	\$859	\$25	\$10
	NOTES: Top box drawer does not lock.						
	Support Pedestals — File/File						
	16"W x 20"D x 28½"H	HLSL2028F	72	7.3	\$689	\$15	\$10
	16"W x 24"D x 28½"H	HLSL2428F	84	8.5	\$762	\$20	\$10
	16"W x 30"D x 28½"H	HLSL3028F	104	10.5	\$859	\$25	\$10
	NOTES: Unit is locking.						
	Slim Profile Pedestals — Box/Box/File						
	9½"W x 24"D x 28½"H	HLSL2428S	69	6.9	\$756	\$20	\$10
	9½"W x 30"D x 28½"H	HLSL3028S	56	5.6	\$831	\$25	\$10
	NOTES: Top box drawer does not lock. ! Grommet will be located under Slim Pedestal when attached.						

NOTES:

- A variety of pedestals, end panels, and O-legs can be combined to create a conventional or contemporary desk.
- Chassis and drawer front woodgrain and solid laminates are specified separately (see SIF options below).
- Will have a 6" overhang when using 30" worksurface supports with a 36"D worksurface.
- File drawers accept hanging folders in letter or legal size.
- Multiple handle locations possible per customer preference.
- Ships with one handle per drawer.
- Drawer Organizer model HSLDRWORG works with box drawers.
- Box and file drawers operate on ball-bearing suspension with full extension.
- Adjustable hex leveling glides allow floor-standing furniture to be easily leveled without lifting the unit; glides have 1¼" adjustable range.
- ! Pedestals ship fully assembled but must attach to a worksurface with a quick release bracket, provided. Pedestals are non-handed and are interchangeable.
- ! Locking units equipped with HON "One Key" interchangeable core removable locks. Keyed alike core must be ordered separately.

HOW TO SPECIFY

Select Model Number	Select Chassis Laminate	Select Drawer Front Laminate	Select Pull Color
See page 171	See page 171	See page 171	See page 171
HLSL2028B	N	N	T4

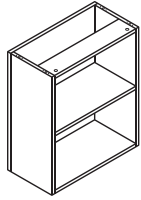
**DESCRIPTION****Bookcase Support**

24"W x 12"D x 28½"H

30"W x 12"D x 28½"H

Specify: Model.Laminate

SPECIFYING EXAMPLE: HLSL24OBC.N**MODEL****HLSL24OBC****HLSL30OBC****SHIP WEIGHT**

60

75

CUBE

3.0

3.0

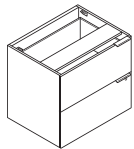
L1 LIST**\$511****\$535****L2 UPCHARGES****\$20****\$25****N/A****N/A****Lateral File — 2 Drawer**

31⅜"W x 24"D x 28½"H

NOTES: Unit is locking.

HLSL2430L

121

15.6

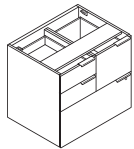
\$1184**\$35****\$20****Multi File Lateral File**

31⅜"W x 24"D x 28½"H

NOTES: Box drawers do not lock.

HLSL2430MF

163

15.6

\$1404**\$35****\$20****NOTES:**

- Ships with one handle per drawer on all units.
- A variety of pedestals, end panels, and O-legs can be combined to create conventional or contemporary desk.
- Bookcase can only mount exterior facing under a worksurface.
- Chassis and drawer front woodgrain and solid laminates are specified separately (see SIF options below).
- File drawers accept hanging folders in letter or legal size.
- Multiple handle locations possible per customer preference.
- Storage accessory model HLSLDRWORG works with box doors.
- Standard box drawers operate on ball-bearing suspension with full extension. File, lateral, and wide box drawers operate on ball-bearing suspension with full extension.
- Adjustable hex leveling glides allow floor-standing furniture to be easily leveled without lifting the unit; glides have 2" adjustable range.
- When using two lateral files, a 60" worksurface cannot be used, a 66" worksurface must be specified, which will show a gap.

! A single multi file or lateral file must be specified under a worksurface 60"W or wider.

! Locking units equipped with HON "One Key" interchangeable core removable locks. Keyed alike core must be ordered separately.

HOW TO SPECIFY

Select Model Number	Select Chassis Laminate	Select Laminate	Select Pull Color
See page 171	See page 171	See page 171	See page 171
H L S L 2 4 3 0 L .	N .	N .	T 4

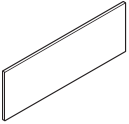
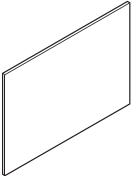
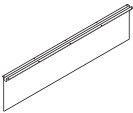

DESCRIPTION	MODEL	SHIP WEIGHT	CUBE	LIST PRICE BY LAMINATE GRADE	
				L1	L2
 <p>Full Width/Half-height Laminate Modesty Panel 28"W x 14"H, for use with 60" desks 34"W x 14"H, for use with 66" desks 40"W x 14"H, for use with 72" desks</p>	HLSL2814LM	19	1.6	\$185	\$195
	HLSL3414LM	23	1.9	\$190	\$200
	HLSL4014LM	29	2.4	\$199	\$209
NOTES: Three sizes available for 60", 66" and 72" desks. Can only be used when using end panels and pedestals for support.					
 <p>Full-to-Floor/Full-Length Laminate Modesty Panel 28"W x 28½"H, for use with 60" desks 34"W x 28½"H, for use with 66" desks 40"W x 28½"H, for use with 72" desks</p>	HLSL2828LM	33	2.7	\$247	\$259
	HLSL3428LM	38	3.2	\$290	\$302
	HLSL4028LM	44	3.6	\$306	\$318
NOTES: Three sizes available for 60", 66" and 72" desks. Can only be used when using end panels and pedestals for support.					
 <p>Laminate Floating Modesty Panel 30"W x 14"H 36"W x 14"H 42"W x 14"H 48"W x 14"H 54"W x 14"H 60"W x 14"H</p>	HLSL3014L	10	0.8	\$169	\$179
	HLSL3614L	12	0.8	\$179	\$189
	HLSL4214L	14	0.8	\$193	\$203
	HLSL4814L	16	1.1	\$212	\$224
	HLSL5414L	18	1.1	\$232	\$244
	HLSL6014L	20	1.1	\$250	\$262
NOTES: The attachment bracket and modesty panel are packaged separately. Specify: Model.Laminate.Paint SPECIFYING EXAMPLE: HLSL3014L.N (Black is the only paint option for this model) ! When specifying the 54"W or 60"W Laminate Floating Modesty Panel, it is not necessary to specify an external channel. ! 30"W and 36"W screens attach with L-brackets, not the external channel.					

NOTES:

- Full width laminate modesty panel (14"H) and full width/full-length laminate modesty panels are designed to work with 60", 66", & 72" desks.
- Laminate and frosted translucent laminate are available options on modesty panels.
- Full height and half height laminate modesty panels can only be used when specifying a pedestal and/or end panel.

HOW TO SPECIFY

<p>Select Model Number</p> <p>H L S L 2 8 1 4 L M .</p>	<p>Select Laminate</p> <p>See page 171</p> <p>N</p>
---	---

VOI® Modesty Panels

GSA SIN 33721

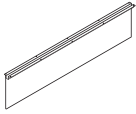

Icon Legend on page 19

**DESCRIPTION****Mixed Material Floating Modesty Panel**

30"W x 14"H
36"W x 14"H
42"W x 14"H
48"W x 14"H
54"W x 14"H
60"W x 14"H

MODEL

HLSL3014MM
HLSL3614MM
HLSL4214MM
HLSL4814MM
HLSL5414MM
HLSL6014MM

SHIP WEIGHT

8
8
9
11
13
13

CUBE

2.0
2.0
2.3
2.6
3.3
3.3

LIST PRICE

\$676
\$726
\$811
\$898
\$974
\$1113

NOTES: The attachment bracket and modesty panel are packaged separately.

Specify: Model.Mixed Material.Paint

SPECIFYING EXAMPLE: HLSL3014MM.FT01 (Frosted Translucent mixed material and Black paint are the only options for this model)

! When specifying the 54"W or 60"W Mixed Material Floating Modesty Panel, it is not necessary to specify an external channel.

NOTES:

- Full width laminate modesty panel (14"H) and full width/full-length laminate modesty panels are designed to work with 60", 66", & 72" desks.
- Laminate and frosted translucent laminate are available options on modesty panels.
- Full height and half height laminate modesty panels can only be used when specifying a pedestal and/or end panel.

FLOATING MODESTY SELECTION GUIDE

Support Combination		Top Size								
Support 1	Support 2	84 in	72 in	66 in	60 in	54 in	48 in	42 in	36 in	30 in
O-Leg/Angled Leg	O-Leg/Angled Leg	NA	HLSL6014	HLSL5414	HLSL4814	HLSL4214	HLSL3614	HLSL3014	NA	NA
O-Leg/Angled Leg	Slim Profile Pedestal	HLSL6014	HLSL5414	HLSL4814	HLSL4214	HLSL3614	HLSL3014	NA	NA	NA
O-Leg/Angled Leg	Bookcase	HLSL6014	HLSL5414	HLSL4814	HLSL4214	HLSL3614	HLSL3014	NA	NA	NA
O-Leg/Angled Leg	Pedestal	HLSL6014	HLSL4814	HLSL4214	HLSL3614	HLSL3014	NA	NA	NA	NA
O-Leg/Angled Leg	End-Panel	HLSL6014	HLSL4814	HLSL4214	HLSL3614	HLSL3014	NA	NA	NA	NA
Slim Profile Pedestal	Slim Profile Pedestal	HLSL6014	HLSL4814	HLSL4214	HLSL3614	HLSL3014	NA	NA	NA	NA
Slim Profile Pedestal	Bookcase	HLSL6014	HLSL4814	HLSL4214	HLSL3614	HLSL3014	NA	NA	NA	NA
Slim Profile Pedestal	Pedestal	HLSL5414	HLSL4214	HLSL3614	HLSL3014	NA	NA	NA	NA	NA
Slim Profile Pedestal	End-Panel	HLSL5414	HLSL4214	HLSL3614	HLSL3014	NA	NA	NA	NA	NA
Pedestal	Bookcase	HLSL5414	HLSL4214	HLSL3614	HLSL3014	NA	NA	NA	NA	NA
End-Panel	Bookcase	HLSL5414	HLSL4214	HLSL3614	HLSL3014	NA	NA	NA	NA	NA
Bookcase	Bookcase	HLSL5414	HLSL4214	HLSL3614	HLSL3014	NA	NA	NA	NA	NA
End-Panel	End-Panel	HLSL4814	HLSL3614	HLSL3014	NA	NA	NA	NA	NA	NA
Pedestal	Pedestal	HLSL4814	HLSL3614	HLSL3014	NA	NA	NA	NA	NA	NA
Pedestal	End-Panel	HLSL4814	HLSL3614	HLSL3014	NA	NA	NA	NA	NA	NA
O-Leg/Angled Leg	Lateral/Multifile	HLSL4214	HLSL3614	HLSL3014	NA	NA	NA	NA	NA	NA
Bookcase	Lateral/Multifile	HLSL3614	NA	NA	NA	NA	NA	NA	NA	NA
Slim Profile Pedestal	Lateral/Multifile	HLSL3614	NA	NA	NA	NA	NA	NA	NA	NA
Pedestal	Lateral/Multifile	HLSL3014	NA	NA	NA	NA	NA	NA	NA	NA
End-Panel	Lateral/Multifile	HLSL3014	NA	NA	NA	NA	NA	NA	NA	NA

HOW TO SPECIFY

Select
Model Number

HLSL3014MM.

Select
Mixed Material

FT01 Frosted Translucent

FT01

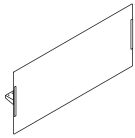

DESCRIPTION

Above/Below Privacy Screen

- 30"W x 28"H
- 36"W x 28"H
- 42"W x 28"H
- 48"W x 28"H
- 54"W x 28"H
- 60"W x 28"H

MODEL SHIP WEIGHT CUBE LIST PRICE

HLSL2830	6	6.4	\$800
HLSL2836	6	6.4	\$1106
HLSL2842	6	6.3	\$1120
HLSL2848	8	8.2	\$1192
HLSL2854	9	8.6	\$1389
HLSL2860	9	8.6	\$1397

NOTES: Attachment bracket extends 2" into the worksurface. Brackets are Platinum only, no need to specify.

! Available in Frosted Translucent Acrylic ONLY HLSL2830.FT01.

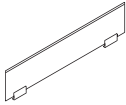

Above Privacy Screen

- 30"W x 13"H
- 36"W x 13"H
- 42"W x 13"H
- 48"W x 13"H
- 54"W x 13"H
- 60"W x 13"H

HLSL1230	13	1.5	\$279
HLSL1236	15	1.8	\$308
HLSL1242	18	2.3	\$344
HLSL1248	20	2.3	\$394
HLSL1254	22	2.9	\$421
HLSL1260	24	2.9	\$453

NOTES: Bracket is Platinum only, no need to specify.

! Available in Frosted Glass ONLY HLSL1230.G.

! Above only Privacy Screen clamps onto worksurface and cannot be installed where support storage will be attached.

NOTES:

- Ships complete with attachment brackets.
- Voi® Privacy Screens can be used on the HON Height Adjustable Base.
- All brackets are Platinum.
- Above Privacy Screen attaches to top of worksurface.
- Above and Below Privacy Screen extends 13" above and 13" below the worksurface.
- ! Above/Below Privacy Screens cannot be used with Knife Edge worksurfaces.

ABOVE-BELOW PRIVACY SCREEN SELECTION GUIDE

Support Combination		Top Size								
Support 1	Support 2	84 in	72 in	66 in	60 in	54 in	48 in	42 in	36 in	30 in
O-Leg/Angled Leg	O-Leg/Angled Leg	NA	HLSL2860	HLSL2854	HLSL2848	HLSL2842	HLSL2836	HLSL2830	NA	NA
O-Leg/Angled Leg	Slim Profile Pedestal	HLSL2860	HLSL2854	HLSL2848	HLSL2842	HLSL2836	HLSL2830	NA	NA	NA
O-Leg/Angled Leg	Bookcase	HLSL2860	HLSL2854	HLSL2848	HLSL2842	HLSL2836	HLSL2830	NA	NA	NA
O-Leg/Angled Leg	Pedestal	HLSL2860	HLSL2848	HLSL2842	HLSL2836	HLSL2830	NA	NA	NA	NA
O-Leg/Angled Leg	End-Panel	HLSL2860	HLSL2848	HLSL2842	HLSL2836	HLSL2830	NA	NA	NA	NA
Slim Profile Pedestal	Slim Profile Pedestal	HLSL2860	HLSL2848	HLSL2842	HLSL2836	HLSL2830	NA	NA	NA	NA
Slim Profile Pedestal	Bookcase	HLSL2860	HLSL2848	HLSL2842	HLSL2836	HLSL2830	NA	NA	NA	NA
Slim Profile Pedestal	Pedestal	HLSL2854	HLSL2842	HLSL2836	HLSL2830	NA	NA	NA	NA	NA
Slim Profile Pedestal	End-Panel	HLSL2854	HLSL2842	HLSL2836	HLSL2830	NA	NA	NA	NA	NA
Pedestal	Bookcase	HLSL2854	HLSL2842	HLSL2836	HLSL2830	NA	NA	NA	NA	NA
End-Panel	Bookcase	HLSL2854	HLSL2842	HLSL2836	HLSL2830	NA	NA	NA	NA	NA
Bookcase	Bookcase	HLSL2854	HLSL2842	HLSL2836	HLSL2830	NA	NA	NA	NA	NA
End-Panel	End-Panel	HLSL2848	HLSL2836	HLSL2830	NA	NA	NA	NA	NA	NA
Pedestal	Pedestal	HLSL2848	HLSL2836	HLSL2830	NA	NA	NA	NA	NA	NA
Pedestal	End-Panel	HLSL2848	HLSL2836	HLSL2830	NA	NA	NA	NA	NA	NA
O-Leg/Angled Leg	Lateral/Multifile	HLSL2842	HLSL2836	HLSL2830	NA	NA	NA	NA	NA	NA
Bookcase	Lateral/Multifile	HLSL2836	NA	NA	NA	NA	NA	NA	NA	NA
Slim Profile Pedestal	Lateral/Multifile	HLSL2836	NA	NA	NA	NA	NA	NA	NA	NA
Pedestal	Lateral/Multifile	HLSL2830	NA	NA	NA	NA	NA	NA	NA	NA
End-Panel	Lateral/Multifile	HLSL2830	NA	NA	NA	NA	NA	NA	NA	NA

HOW TO SPECIFY

Select Model Number

HLSL2830 .

HLSL1230 .

Select Mixed Material

FT01 Frosted Translucent Acrylic
Specified for Above/Below Privacy Screens only

G Frosted Glass
Specified for Above Privacy Screens only

FT01

G

VOI® Privacy Screens

GSA SIN 33721

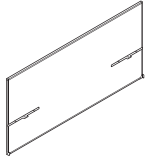

Icon Legend on page 19

**DESCRIPTION****Above/Below Fabric Privacy Screen**

36"W x 35"H
42"W x 35"H
48"W x 35"H
54"W x 35"H
60"W x 35"H
66"W x 35"H
72"W x 35"H

MODEL

HLSSL3635TS
HLSSL4235TS
HLSSL4835TS
HLSSL5435TS
HLSSL6035TS
HLSSL6635TS
HLSSL7235TS

**SHIP
WEIGHT**

21
27
33
39
45
51
57

CUBE

3.8
4.4
6.0
6.0
6.0
7.4
7.4

CORE LIST PRICE BY CODE**A**

\$865
\$909
\$967
\$1011
\$1073
\$1131
\$1181

B

\$890
\$934
\$1002
\$1046
\$1116
\$1174
\$1224

NOTES: Brackets are Platinum only, no need to specify. Above/Below Privacy Screens must be ordered the same width as the worksurface it is being used with to properly attach.

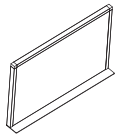
**Above Fabric (Side) Privacy Screen**

20"W x 20"H
24"W x 20"H
30"W x 20"H
36"W x 20"H

HLSSL2020TS
HLSSL2024TS
HLSSL2030TS
HLSSL2036TS

13 Ⓞ
15 Ⓞ
17 Ⓞ
19 Ⓞ

1.4
1.4
1.9
2.2

\$335
\$345
\$361
\$398

\$342
\$353
\$372
\$411

20"W x 13"H
24"W x 13"H
30"W x 13"H
36"W x 13"H

HLSSL1220TS
HLSSL1224TS
HLSSL1230TS
HLSSL1236TS

11 Ⓞ
13 Ⓞ
15 Ⓞ
17 Ⓞ

1.1
1.1
1.6
1.9

\$320
\$325
\$341
\$361

\$326
\$331
\$348
\$369

NOTES: Brackets are Platinum only, no need to specify. Brackets intended to be attached between users sitting side-by-side, and will create 1/8" separation between worksurfaces.

NOTES:

- Ships complete with attachment brackets.
 - All brackets are Platinum.
 - Above Privacy Screen attaches to top and side of worksurface with adhesive banding.
 - Lower attachment brackets may be shifted to attach to support components.
 - Above/Below Privacy Screen extends 20" above and 13" below worksurface.
- ❗ Screens cannot be used with T-mold on series such as tables. Screens can only attach to edgeband. Surfaces must be cleaned prior to adhering the screen and must be left to cure for 24 hours without touching for best adhesion.
- ❗ Above/Below Fabric Privacy Screens can attach to worksurfaces that are either O-leg supported on both sides, or worksurfaces that are supported by a support pedestal on one side and an O-leg on the other. They cannot be attached to worksurfaces supported by support pedestals on both sides, unless additional hardware is specified.
- ❗ Above Screens must attach to edgeband and top of surface.
- ❗ Above/Below Privacy Screens must be ordered the same width as the worksurface it is being used with to properly attach.
- ❗ Above/Below Privacy Screens cannot be used with Knife Edge worksurfaces.
- ❗ Shared O-legs should not be used with Above/Below Fabric Privacy Screens.

HOW TO SPECIFY

Select
Model Number

HLSSL3635TS.

Select
Fabric

See pages 25-26

PN15

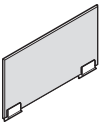
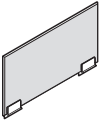

	DESCRIPTION	MODEL	SHIP WEIGHT	CUBE	LIST PRICE
	Above Frosted Polymer (Side) Privacy Screen				
	20"W x 13"H	HLSL1220FS	12 Ⓞ	1.3	\$309
	24"W x 13"H	HLSL1224FS	14 Ⓞ	1.4	\$329
	30"W x 13"H	HLSL1230FS	16 Ⓞ	1.6	\$356
	36"W x 13"H	HLSL1236FS	19 Ⓞ	1.9	\$398
	NOTES: Brackets are Platinum only, no need to specify. Brackets intended to be attached between users sitting side-by-side, and will create 1/8" separation between worksurfaces.				
	Above Frosted Glass (Side) Privacy Screen				
	20"W x 13"H	HLSL1220GS	13 Ⓞ	1.3	\$258
	24"W x 13"H	HLSL1224GS	16 Ⓞ	1.4	\$274
	30"W x 13"H	HLSL1230GS	18 Ⓞ	1.6	\$297
	36"W x 13"H	HLSL1236GS	20 Ⓞ	1.9	\$331
	NOTES: Brackets are Platinum only, no need to specify. Brackets intended to be attached between users sitting side-by-side, and will create 1/8" separation between worksurfaces.				

NOTES:

- Above Privacy Screens are intended to be attached between users sitting side-by-side but will create 1/8" spacing between the worksurfaces. Please consider stack up if using in a panel-wrapped application.
- Ships complete with attachment brackets.
- All brackets are Platinum.
- Above Privacy Screen attaches to top and side of worksurface with adhesive banding.
- Lower attachment brackets may be shifted to attach to support components.
- Above/Below Privacy Screen extends 20" above and 13" below worksurface.
- ❗ Screens cannot be used with T-mold on series such as tables. Screens can only attach to edgeband. Surfaces must be cleaned prior to adhering the screen and must be left to cure for 24 hours without touching for best adhesion.

HOW TO SPECIFY

<p>Select Model Number</p>	<p>Select Mixed Material</p> <p>FT01 Frosted Translucent Acrylic Specified for Above Screen models HLSL1220FS-HLSL1236FS only</p> <p>G Frosted Glass Specified for Above Screen models HLSL1220GS-HLSL1236GS only</p>
<p>H L S L 1 2 2 0 F S .</p> <p>H L S L 1 2 2 0 G S .</p>	<p>F T 0 1</p> <p>G</p>

VOI® Laminate Overhead Storage

GSA SIN 33721



Icon Legend on page 19

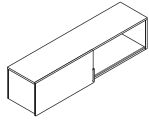

DESCRIPTION	MODEL	SHIP WEIGHT	CUBE	L1 LIST	L2 UPCHARGES	
					CABINET	DOOR
Overhead Cabinet with One Sliding Door						
36"W x 14¼"D x 14"H	HLSL1436S	39	9.7	\$999	\$25	\$20
42"W x 14¼"D x 14"H	HLSL1442S	48	9.7	\$1047	\$25	\$20
48"W x 14¼"D x 14"H	HLSL1448S	57	12.1	\$1078	\$25	\$20
60"W x 14¼"D x 14"H	HLSL1460S	69	13.3	\$1161	\$30	\$25
66"W x 14¼"D x 14"H	HLSL1466S	83	14.6	\$1282	\$30	\$25
72"W x 14¼"D x 14"H	HLSL1472S	95	15.9	\$1400	\$35	\$25

NOTES:

- Sliding door overhead does not ship with a pull — door overhangs chassis to slide.

HOW TO SPECIFY

Select Model Number For locking overhead models, add an "L" suffix (\$40 upcharge per model)	Select Cabinet Laminate See page 171	Select Door Laminate See page 171	Select Pull Option <input checked="" type="checkbox"/> No Pull	Specify Bracket Option <input checked="" type="checkbox"/> No Bracket <input type="checkbox"/> Wall Bracket (\$150 upcharge)
H L S L 1 4 7 2 S .	N .	N .	X .	W

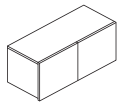

DESCRIPTION	MODEL	SHIP WEIGHT	CUBE	L1 LIST	L2 UPCHARGES	
					CABINET	DOOR
Overhead Cabinet with Doors						
36"W x 14¼"D x 14"H, 2 doors	HLSL1436D	39	9.7	\$842	\$25	\$20
42"W x 14¼"D x 14"H, 2 doors	HLSL1442D	48	9.7	\$937	\$25	\$20
48"W x 14¼"D x 14"H, 3 doors	HLSL1448D	57	12.1	\$1040	\$25	\$30
60"W x 14¼"D x 14"H, 4 doors	HLSL1460D	115	13.3	\$1161	\$30	\$30

! 2-Door and 3-Door Overhead Cabinet with Doors models HLSL1436D–HLSL1448D available in laminate only. The 60" model HLSL1460D is available in all door finish options—see "Select Door Material for 2/3/4 Door Models" below.

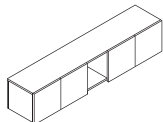

Overhead Cabinet with 4 Doors/Cubbies						
66"W x 14¼"D x 14"H with 6" Cubbie	HLSL1466D	126	14.6	\$1282	\$30	\$30
72"W x 14¼"D x 14"H with 12" Cubbie	HLSL1472D	139	15.9	\$1400	\$35	\$35

NOTES: Doors available in laminate or mixed materials.

NOTES:

- All Overhead Cabinets shown above can be used as a wall mount, panel mount or stack-on storage with O-leg.
- are available for wall mount storage applications and conventional stack-on. Use wall mount when using O-leg supports.
- 5½"H and 20½"H O-legs can be purchased to create stack-on storage. Heights line up with Abound® and Accelerate® panels.
- Overhead cabinets with four doors are available in laminate or mixed materials.
- Wall mount brackets specified with unit. Brackets attach to case horizontally.
- Storage cases accept binder height items.
- The Metal Storage Cube HLSL1212 fits inside stack-on storage or overhead cabinet units to provide paper management.
- For panel mounted applications, brackets and hardware are ordered separately, see pages 542-543. Brackets attach to panel and case is screwed into brackets. Two brackets needed for 60" unit.
- ! Stack-on Storage must be placed over two full-height supports. Cannot be placed over non-supported sections such as returns using a flat bracket or tower-to-worksurface bracket.
- ! 1G doors not available with a locking option.

HOW TO SPECIFY

Select Model Number For locking overhead models, add an "L" suffix (\$40 upcharge per model)	Select Cabinet Laminate See page 171	Select Door Material for 2/3/4 Door Models Upcharge for door selection: 4-Door \$315 T1G Platinum Polymer with Frosted glass Also available in laminate doors. See page 171. Not specified for models HLSL1436D–HLSL1448D. These models are available in laminate only.	Select Bracket Option <input checked="" type="checkbox"/> No Bracket <input type="checkbox"/> Wall Bracket (\$150 upcharge)
H L S L 1 4 6 0 D .	N .	T 1 G .	X

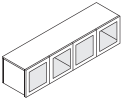
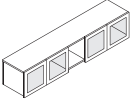
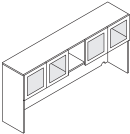

Laminate Overhead and Stack-on Storage

	DESCRIPTION	MODEL	SHIP WEIGHT	CUBE	LIST PRICE BY LAMINATE GRADE	
					L1	L2
	Overhead Cabinet with 4 Frosted, Metal Frame Doors 60"W x 14¼"D x 14"H	HLSL1460M	115	11.4	\$1893	\$1923
	! Must specify an X or W for attachment bracket option below.					
	Overhead Cabinet with 4 Frosted, Metal Frame Doors 72"W x 14¼"D x 14"H with 12" Cubbie	HLSL1472M	139	13.6	\$2134	\$2169
	66"W x 14¼"D x 14"H with 6" Cubbie	HLSL1466M	126	12.5	\$2013	\$2043
	! Must specify an X or W for attachment bracket option below.					
	Stack-on Storage, Built-up with 4 Frosted Doors with Metal Frame with Cubbies 72"W x 14¼"D x 35"H with 12" Cubbie	HLSL1472MB	165	30.4	\$2247	\$2292
	NOTES: Ships complete with Back Enclosure and laminate End Panels. Ships factory assembled.					
	! Does not require bracket specification.					



	DESCRIPTION	MODEL	SHIP WEIGHT	CUBE	LIST PRICE BY FABRIC GRADE	
					A	B
	for Wall Mount Overhead Cabinets 18½"H					
	For 78"W	HLSL78TW	13	1.4	\$383	\$395
	For 72"W	HLSL72TW	12	1.4	\$364	\$376
	For 66"W	HLSL66TW	11	1.4	\$349	\$361
	For 60"W	HLSL60TW	10	1.1	\$310	\$322
	For 48"W	HLSL48TW	13	1.4	\$270	\$280
	For 42"W	HLSL42TW	12	1.4	\$251	\$261
	For 36"W	HLSL36TW	11	1.4	\$237	\$247
	SPECIFYING EXAMPLE: HLSL48TW.DB30					

NOTES:

- Use O-Leg Support models for Overhead Cabinets. See page 207.
- The Metal Storage Cube HLSL1212 fits inside stack-on storage or wall mount units to provide paper management. See page 207.
- ! Metal Frame Overhead and Stack-on Storage units are not available with a lock.
- ! Stack-on Storage must be placed over two full-height supports. Cannot be placed over non-supported sections such as returns using a flat bracket or tower-to-worksurface bracket.
- ! Specify fabric, see pages 25-26. Upcharges may apply to premium fabric grades. Analog (ANLG), Disperse (DISP), and Exchange (EXG) not available on sizes wider than 72".

HOW TO SPECIFY

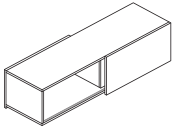
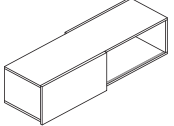
<p>Select Model Number</p> <p>HLSL1460M</p>	<p>Select Cabinet Laminate</p> <p>See page 171</p> <p>N</p>	<p>Select Door Material</p> <p>TIG Platinum Metal Doors with Frosted Glass (no upcharge)</p> <p>TIG</p>	<p>Select Bracket Option</p> <p>X No Bracket W Wall Bracket (\$150 upcharge) Not specified for model HLSL1472MB</p> <p>X</p>
--	--	--	---

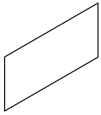
	DESCRIPTION	MODEL	SHIP WEIGHT	CUBE	L1 LIST	L2 UPCHARGES	
						CABINET	DOOR
	Shared Overhead Storage — Left						
	60"W x 17"D x 14"H 72"W x 17"D x 14"H	HLSL1760SOL HLSL1772SOL	115 139	14.8 17.0	\$1277 \$1539	\$20 \$25	\$40 \$40
	Shared Overhead Storage — Right						
	60"W x 17"D x 14"H 72"W x 17"D x 14"H	HLSL1760SOR HLSL1772SOR	115 139	14.8 17.0	\$1277 \$1539	\$20 \$25	\$40 \$40
	DESCRIPTION	MODEL	SHIP WEIGHT	CUBE	LIST PRICE BY PAINT GRADE		
					P1	P2	P3
	Post Legs for Shared Storage						
	14"H Post Legs 22"H Post Legs	HLSL140SPL HLSL220SPL	10 Ⓢ 13 Ⓢ	1.1 3.7	\$339 \$375	\$343 \$379	\$359 \$395
	NOTES: 14"H post legs on worksurfaces will span 35"H panel or shorter. 14"H post legs on low credenzas will span 30"H panel or shorter. 22"H post legs on worksurfaces will span 50"H panel or shorter. 22"H post legs on low credenzas will span 35"H panel or shorter. Specify paint.						
	SPECIFYING EXAMPLE: HLSL140SPL.T4						
	Panel Mount Bracket for Shared Overhead						
	Panel Mount Bracket for Overhead Storage — Accelerate®	HLSLPMBSOA	4 Ⓢ	0.1	\$136	\$140	N/A
	Panel Mount Bracket for Overhead Storage — Abound®	HLSLPMBSOB	4 Ⓢ	0.1	\$136	\$140	N/A
	Panel Mount Bracket for Overhead Storage — Accelerate®/Abound® 4 1/2"H panels only	HLSLPMBSO42	4 Ⓢ	0.1	\$127	\$131	N/A
	NOTES: Specify paint.						
	SPECIFYING EXAMPLE: HLSLPMBSOA.T4						
	for Shared Storage						
	30"W x 13"H for use with 60"W Shared Overhead 36"W x 13"H for use with 72"W Shared Overhead	HLSL1530SOMB HLSL1536SOMB	6 Ⓢ 8 Ⓢ	1.0 1.0	\$132 \$179		
	NOTES: No specification necessary.						

NOTES:

- Overall case depth is 19"D including the sliding door.
- Use Shared Overhead and attachments in small footprint applications.
- Sliding door is 15"H, providing a 1" valance below the case which can be used as a finger pull if desired.
- Shared Overhead panel mount brackets and overhead post legs allow overhead to span over all panels systems or run down the spine wall, centered on top of the panel.
- Post legs can attach to all low credenza models and all worksurface models.
- insert is laminate with black edges, no frame.
- ⓘ Shared Overhead must be ordered as left or right to determine open storage location.
- ⓘ Shared Overhead Storage is not available with a lock.

HOW TO SPECIFY

Select Model Number HLSL1760SOL .	Select Chassis Laminate See page 171 N .	Select Door Front Laminate See page 171 N
Select Model Number HLSL140SPL .	Select Paint Color See page 171 T4	

Icon Legend on page 19

Overhead Storage Supports/Accessories

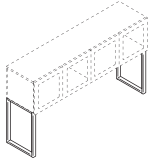

DESCRIPTION	MODEL	SHIP WEIGHT	CUBE	LIST PRICE BY PAINT GRADE		
				P1	P2	P3
O-Leg Support for Overhead Cabinet Ships 2/pack 14 7/8" D x 20 1/2" H	HLSL650S	8	1.1	\$468	\$472	\$488
14 7/8" D x 5 1/2" H	HLSL500S	6	1.0	\$390	\$394	\$410

NOTES: 20 1/2" H legs used to reach 65" H when overhead storage is stacked on top of a worksurface. 5 1/2" H legs used to reach 50" H when overhead storage is stacked on top of a worksurface. O-leg ships fully assembled with mounting hardware. O-legs can be used with all overhead cabinet models. See pages 204 and 205.

- ⚠ Not for use on Shared Overhead Storage, use post leg models on page 206.
- ⚠ Stack-on Storage must be placed over two full-height supports. Cannot be placed over non-supported sections such as returns using a flat bracket or tower-to-worksurface bracket.

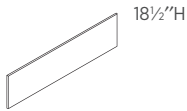

DESCRIPTION	MODEL	SHIP WEIGHT	CUBE	LIST PRICE BY FABRIC GRADE	
				A	B
Wall Mounted For 78" W	HLSL78TW	13	1.4	\$383	\$395
For 72" W	HLSL72TW	12	1.4	\$364	\$376
For 66" W	HLSL66TW	11	1.4	\$349	\$361
For 60" W	HLSL60TW	10	1.1	\$310	\$322
For 48" W	HLSL48TW	13	1.4	\$270	\$280
For 42" W	HLSL42TW	12	1.4	\$251	\$261
For 36" W	HLSL36TW	11	1.4	\$237	\$247

NOTES: Specify fabric, see pages 25-26. Upcharges may apply to premium fabric grades. Analog (ANLG), Disperse (DISP), and Exchange (EXG) not available on sizes wider than 72".

SPECIFYING EXAMPLE: HLSL78TW.APN23



DESCRIPTION	MODEL	SHIP WEIGHT	CUBE	LIST PRICE
Storage Cube 12" W x 12" D	HLSL1212	1	0.3	\$294

SPECIFYING EXAMPLE: HLSL1212.P8S

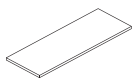

DESCRIPTION	MODEL	SHIP WEIGHT	CUBE	L1 LIST PRICE	L2 UPCHARGE
Shelves 30" W x 13" D	HLSLR1330	10 Ⓞ	1.3	\$187	\$10
36" W x 13" D	HLSLR1336	12 Ⓞ	1.5	\$210	\$10
45" W x 13" D	HLSLR1345	15 Ⓞ	1.9	\$228	\$10

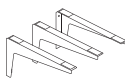

DESCRIPTION	MODEL	SHIP WEIGHT	CUBE	LIST PRICE BY PAINT GRADE		
				P1	P2	P3
Shelf Bracket (set of 3)	HLSLSB	3 Ⓞ	0.2	\$96	\$104	\$116

HOW TO SPECIFY

Select Model Number HLSL650S	Select Laminate/Paint See page 171 T1
--	--

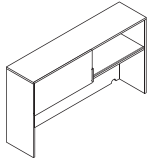

DESCRIPTION	MODEL	SHIP WEIGHT	CUBE	L1 LIST	L2 UPCHARGES	
					CABINET	DOOR
Stack-on Storage, Built-up, with Sliding Doors 72"W x 14¼"D x 35"H NOTES: Ships complete with Back Enclosure and laminate End Panels. Ships factory assembled.	HLSL1472SB	139	30.4	\$1522	\$45	\$20

HOW TO SPECIFY

Select Model Number HLSL1472SB	Select Cabinet Laminate See page 171 L2 (\$45 upcharge) N	Select Door Laminate See page 171 L2 (\$20 upcharge) N	Select Pull Option X No Pull
--	---	--	--

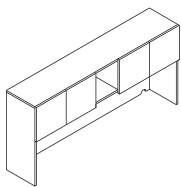

DESCRIPTION	MODEL	SHIP WEIGHT	CUBE	L1 LIST	L2 UPCHARGES	
					CABINET	DOOR
Stack-on Storage, Built-up, with 4 Doors/Cubbies 72"W x 14¼"D x 35"H with 12" Cubbie NOTES: Ships complete with Back Enclosure and laminate End Panels. Ships factory assembled.	HLSL1472DB	144	30.4	\$1522	\$45	N/A

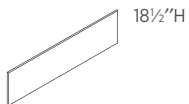

DESCRIPTION	MODEL	SHIP WEIGHT	CUBE	LIST PRICE BY FABRIC GRADE	
				A	B
18½"H for Built-up Stack-on Storage For 72" NOTES: For a list of standard fabrics, see pages 25-26. For a complete list of fabrics, please go to hon.com/fabricsandfinishes. Analog (ANLG), Disperse (DISP), and Exchange (EXG) not available on sizes wider than 72". SPECIFYING EXAMPLE: HLSL7265TE.APN23	HLSL7265TE	12	1.4	\$364	\$376

NOTES:

- The Metal Storage Cube HLSL1212 fits inside stack-on storage or wall mount units to provide paper management.
- Stack-on Storage is not available with a lock.
- are available for Built-up models only. cannot be added to O-leg supported units.
- Stack-on Storage must be placed over two full-height supports. Cannot be placed over non-supported sections such as returns using a flat bracket or tower-to-worksurface bracket.

HOW TO SPECIFY

Select Model Number HLSL1472DB	Select Cabinet Chassis Laminate See page 171 L2 (\$45 upcharge) N	Select Door Material for 4-Door Models Upcharge for door selection: <table border="0" style="width: 100%;"> <tr> <td>T1G Platinum Polymer with Frosted glass</td> <td style="text-align: right;">4-Door \$315</td> </tr> </table> Also available in laminate doors. See page 171.	T1G Platinum Polymer with Frosted glass	4-Door \$315
T1G Platinum Polymer with Frosted glass	4-Door \$315			

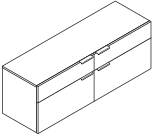
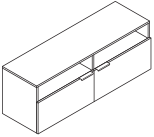
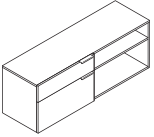
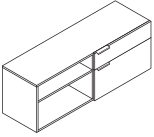
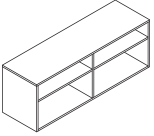

	DESCRIPTION	MODEL	SHIP WEIGHT	CUBE	L1 LIST	L2 UPCHARGES	
						CHASSIS	FRONTS
	Low Credenza, 2 File/2 Box 72"W x 20"D x 21½"H 60"W x 20"D x 21½"H	HLSL2072LD4	230	21.9	\$1605	\$40	\$40
	NOTES: Unit is locking.	HLSL2060LD4	190	18.9	\$1462	\$35	\$40
	Low Credenza, 2 File Drawers, Open Top 72"W x 20"D x 21½"H 60"W x 20"D x 21½"H	HLSL2072LD2	200	21.9	\$1501	\$40	\$30
	NOTES: Unit is non-locking.	HLSL2060LD2	160	18.9	\$1370	\$35	\$30
	Low Credenza, Left Hand Drawers 72"W x 20"D x 21½"H 60"W x 20"D x 21½"H	HLSL2072LL2	200	21.9	\$1486	\$40	\$20
	NOTES: Unit is locking.	HLSL2060LL2	160	18.9	\$1254	\$35	\$20
	Low Credenza, Right Hand Drawers 72"W x 20"D x 21½"H 60"W x 20"D x 21½"H	HLSL2072LR2	200	21.9	\$1486	\$40	\$20
	NOTES: Unit is locking.	HLSL2060LR2	160	18.9	\$1254	\$35	\$20
	Low Credenza, Open 72"W x 20"D x 21½"H 60"W x 20"D x 21½"H	HLSL2072LDO	170	21.9	\$1262	\$40	N/A
		HLSL2060LDO	130	18.9	\$1048	\$35	N/A
	SPECIFYING EXAMPLE: HLSL2072LDO.Z (model.chassis only)						
	Low Credenza, 4 Storage Doors 72"W x 20"D x 21½"H 60"W x 20"D x 21½"H	HLSL2072S4	190	21.9	\$1593	\$40	\$40
	NOTES: Unit is locking.	HLSL2060S4	160	18.9	\$1367	\$35	\$40

NOTES:

- Worksurfaces with 7" O-legs, may be placed upon low credenzas to create layering.
- Chassis and drawer fronts woodgrains and solid laminates are specified separately (see SIF options below).
- File drawers accept hanging folders in letter size.
- Multiple handle locations possible per customer preference.
- Seat cushions are available for low credenzas and mobile pedestals (specify separately).
- Storage accessory model HLSLDRWORG works with box doors.
- Layering shelf works with low credenzas to provide additional storage areas.
- File, lateral, and wide box drawers operate on ball-bearing suspension with full extension.
- Adjustable hex leveling glides allow floor-standing furniture to be easily leveled without lifting the unit; glides have 1/4" adjustable range.
- Ships with one handle per drawer on all units.

! Locking units equipped with HON "One Key" interchangeable core removable locks. Keyed alike core must be ordered separately.

HOW TO SPECIFY

Select Model Number	Select Chassis Laminate See page 171	Select Drawer Front Laminate See page 171	Select Pull Color See page 171 Not specified for Open Credenza models HLSL2072LDO, HLSL2060LDO
HLSL2072LD4	N	N	T4

VOI® Laminate Low Credenzas

GSA SIN 33721

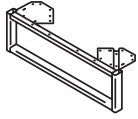

Icon Legend on page 19

**DESCRIPTION****7" O-Leg Support for Worksurfaces**

30"D x 7"H

24"D x 7"H

20"D x 7"H

Specify: Model.Paint HL3070.T1.

NOTES: 7" O-Leg Support to be placed upon Low Credenza models to support worksurfaces. Ship 1/pack.

MODEL**SHIP WEIGHT****CUBE****LIST PRICE BY PAINT GRADE****P1****P2****P3****HL3070**

7

1.0

\$271**\$275****\$291****HL2470**

6

1.0

\$213**\$217****\$233****HL2070**

5

1.0

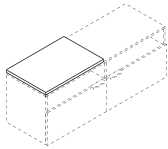
\$197**\$201****\$217****DESCRIPTION****Credenza Cushion**

20"W x 36"D x 1"H for 72" Credenzas

20"W x 30"D x 1"H for 60" Credenzas

NOTES: See pages 22-24 for available fabrics.

COM: .75**SPECIFYING EXAMPLE: HL2036CH2.APN23****MODEL****SHIP WEIGHT****CUBE****LIST PRICE BY FABRIC GRADE****1****2****3****4****5****6****HL2036CH2**

11

2.2

\$402**\$440****\$478****\$517****\$566****\$616****HL2030CH2**

9

1.9

\$372**\$408****\$444****\$480****\$526****\$573****NOTES:**



- Worksurfaces with 7" O-legs, may be placed upon low credenzas to create layering.
- Chassis and drawer fronts woodgrains and solid laminates are specified separately (see SIF options on preceding page).
- Seat cushions are available for low credenzas and mobile pedestals (specify separately).
- Storage accessory model HLSDRWORG works with box doors.
- Layering shelf works with low credenzas to provide additional storage areas.
- File, lateral, and wide box drawers operate on ball-bearing suspension with full extension.
- Adjustable hex leveling glides allow floor-standing furniture to be easily leveled without lifting the unit; glides have 1/4" adjustable range.
- Ships with one handle per drawer on all units.

HOW TO SPECIFY**Select Model Number****Select Paint Color**

See page 171

HL3070.T1

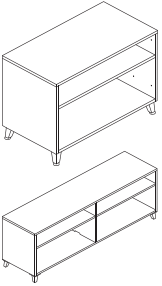
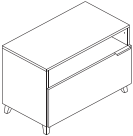
Laminate Low Footed Credenzas

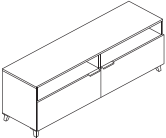
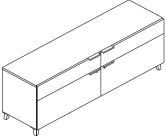
	DESCRIPTION	MODEL	SHIP WEIGHT	CUBE	L1 LIST	L2 UPCHARGES	
						CHASSIS	FRONTS
	Low Credenza, Open, Footed						
	30"W x 20"D x 24½"H	HLSL2030LD0F	67	9.8	\$924	\$25	N/A
	36"W x 20"D x 24½"H	HLSL2036LD0F	87	11.9	\$950	\$30	N/A
	60"W x 20"D x 24½"H	HLSL2060LD0F	132	19.9	\$1118	\$35	N/A
	72"W x 20"D x 24½"H	HLSL2072LD0F	172	23.7	\$1332	\$40	N/A
	Low Credenza, 1 File/Open, Footed						
	30"W x 20"D x 24½"H	HLSL2030LD1F	77	9.8	\$1020	\$25	\$15
	36"W x 20"D x 24½"H	HLSL2036LD1F	97	11.9	\$1048	\$30	\$15
	Low Credenza, 1 File/1 Box, Footed						
	30"W x 20"D x 24½"H	HLSL2030LD2F	82	9.8	\$1127	\$25	\$20
	36"W x 20"D x 24½"H	HLSL2036LD2F	102	11.9	\$1159	\$30	\$20
	Low Credenza, 2 File/Open, Footed						
	60"W x 20"D x 24½"H	HLSL2060LD2F	162	19.9	\$1440	\$35	\$30
	72"W x 20"D x 24½"H	HLSL2072LD2F	202	23.7	\$1571	\$40	\$30
	Low Credenza, 2 File/2 Box, Footed						
	60"W x 20"D x 24½"H	HLSL2060LD4F	192	19.9	\$1532	\$35	\$40
	72"W x 20"D x 24½"H	HLSL2072LD4F	232	23.7	\$1675	\$40	\$40

NOTES:

- Worksurfaces with 4" stanchions may be placed upon low credenzas to create layering.
- Chassis and drawer fronts woodgrains and solid laminates are specified separately (see SIF options below).
- File drawers accept hanging folders in letter size.
- Multiple handle locations possible per customer preference.
- Seat cushions are available for low credenzas (specify separately).
- Storage accessory model HLSLDRWORG works with box drawers.
- Layering shelf works with low credenzas to provide additional storage areas.
- File, lateral, and wide box drawers operate on ball-bearing suspension with full extension.
- Adjustable hex leveling glides allow floor-standing furniture to be easily leveled without lifting the unit; glides have 1/4" adjustable range.
- Ships with one handle per drawer on all units.

❗ Locking units equipped with HON "One Key" interchangeable core removable locks. Keyed alike core must be ordered separately.

❗ 7" O-legs cannot be used as a support on footed credenzas.

HOW TO SPECIFY

Select Model Number	Select Chassis Laminate	Select Drawer Front Laminate	Select Pull Color	Select Foot Color
	See page 171	See page 171	See page 171 Not specified for Open Credenza models	See page 171
HLSL2030LD0F	C	C	T1	T1

Laminate Low Footed Credenzas

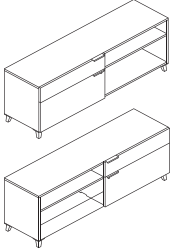
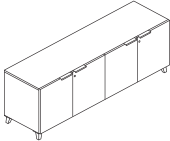
	DESCRIPTION	MODEL	SHIP WEIGHT	CUBE	L1 LIST	L2 UPCHARGES	
						CHASSIS	FRONTS
	Low Credenza, Box/File, Open, Footed						
	60"W x 20"D x 24½"H — Left Hand Drawers	HLSL2060LL2F	162	19.9	\$1324	\$35	\$20
	72"W x 20"D x 24½"H — Left Hand Drawers	HLSL2072LL2F	202	23.7	\$1556	\$40	\$20
	60"W x 20"D x 24½"H — Right Hand Drawers	HLSL2060LR2F	162	19.9	\$1324	\$35	\$20
	72"W x 20"D x 24½"H — Right Hand Drawers	HLSL2072LR2F	202	23.7	\$1556	\$40	\$20
	Low Credenza, 4 Storage Doors, Footed						
	60"W x 20"D x 24½"H	HLSL2060S4F	162	19.9	\$1437	\$35	\$40
	72"W x 20"D x 24½"H	HLSL2072S4F	192	23.7	\$1663	\$40	\$40

NOTES:

- Worksurfaces with 4" stanchions may be placed upon low credenzas to create layering.
- Chassis and drawer fronts woodgrains and solid laminates are specified separately (see SIF options below).
- File drawers accept hanging folders in letter size.
- Multiple handle locations possible per customer preference.
- Seat cushions are available for low credenzas and mobile pedestals (specify separately).
- Storage accessory model HLSLDRWORG works with box doors.
- Layering shelf works with low credenzas to provide additional storage areas.
- File, lateral, and wide box drawers operate on ball-bearing suspension with full extension.
- Adjustable hex leveling glides allow floor-standing furniture to be easily leveled without lifting the unit; glides have 1/4" adjustable range.
- Ships with one handle per drawer on all units.

ⓘ Locking units equipped with HON "One Key" interchangeable core removable locks. Keyed alike core must be ordered separately.

ⓘ 7" O-legs cannot be used as a support on footed credenzas.

HOW TO SPECIFY

Select Model Number See page 171	Select Chassis Laminate See page 171	Select Drawer Front Laminate See page 171	Select Pull Color See page 171 Not specified for Open Credenza models	Select Foot Color See page 171
H L S L 2 0 6 0 L L 2 F .	C .	C .	T 1 .	T 1



Icon Legend on page 19

	DESCRIPTION	MODEL	SHIP WEIGHT	CUBE	L1 LIST	L2 UPCHARGES	
						CHASSIS	FRONTS
	Low Credenza — Open 30"W x 20"D x 21½"H 36"W x 20"D x 21½"H	HLSL2030LDO	65	9.8	\$868	\$25	N/A
		HLSL2036LDO	85	12.0	\$894	\$30	N/A
	Low Credenza — Open Top, File Drawer 30"W x 20"D x 21½"H 36"W x 20"D x 21½"H NOTES: Unit is non-locking.	HLSL2030LD1	75	9.8	\$964	\$25	\$15
		HLSL2036LD1	95	12.0	\$992	\$30	\$15
	Low Credenza — 1 File Drawer, 1 Box Drawer 30"W x 20"D x 21½"H 36"W x 20"D x 21½"H NOTES: Unit is locking.	HLSL2030LD2	80	9.8	\$1071	\$25	\$20
		HLSL2036LD2	100	12.0	\$1103	\$30	\$20

NOTES:

- Worksurfaces with 7" O-legs, may be placed upon low credenzas to create layering.
- File drawers accept hanging folders in letter size.
- Multiple handle locations possible per customer preference.
- Post legs on Shared Overhead are compatible to attach to low credenzas.
- Storage accessory model HLSLDRWORG works with box doors.
- File, lateral, and wide box drawers operate on ball-bearing suspension with full extension.
- Utilize in small footprint applications.
- Adjustable hex leveling glides allow floor-standing furniture to be easily leveled without lifting the unit; glides have 1/4" adjustable range.
- Ships with one handle per drawer on all units.

ⓘ Locking units equipped with HON "One Key" interchangeable core removable locks. Keyed alike core must be ordered separately.

HOW TO SPECIFY

<p>Select Model Number</p> <p>See page 171</p> <p>H L S L 2 0 3 0 L D O .</p>	<p>Select Chassis Laminate</p> <p>See page 171</p> <p>N .</p>	<p>Select Drawer Front Laminate</p> <p>See page 171</p> <p>Not specified for Open Credenza models HLSL2030LDO, HLSL2036LDO</p> <p>N .</p>	<p>Select Pull Color</p> <p>See page 171</p> <p>Not specified for Open Credenza models HLSL2030LDO, HLSL2036LDO</p> <p>T 4</p>
--	--	--	---

VOI® Laminate Mobile Storage

GSA SIN 33721

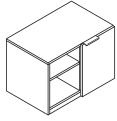

Icon Legend on page 19

**DESCRIPTION**

Mobile Credenza
30"W x 20"D x 21½"H

NOTES: Unit is non-locking.

MODEL

HLSL2030MCO

SHIP WEIGHT

80

CUBE

9.8

L1 LIST

\$1399

L2 UPCHARGES

CHASSIS \$25

FRONTS \$10

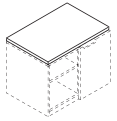
**DESCRIPTION**

Credenza Cushion
20"W x 30"D x 1"H for 60" Credenzas

NOTES: See pages 22-24 for available fabrics.

! COM: .75

SPECIFYING EXAMPLE: HLSL2030CH2.APN23

MODEL

HLSL2030CH2

SHIP WEIGHT

9

CUBE

1.9

LIST PRICE BY FABRIC GRADE

1	2	3	4	5	6
\$372	\$408	\$444	\$480	\$526	\$573

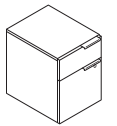
**DESCRIPTION**

Mobile Pedestal
15¾"W x 20⅞"D x 21⅞"H

NOTES: Unit is locking.

MODEL

HLSL2016MP2

SHIP WEIGHT

65

CUBE

5.7

L1 LIST

\$794

L2 UPCHARGES

CHASSIS \$20

FRONTS \$10

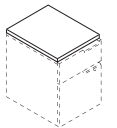
**DESCRIPTION**

Mobile Pedestal Cushion
15⅞"W x 20"D x 1"H for Pedestals

NOTES: See pages 22-24 for available fabrics.

SPECIFYING EXAMPLE: HLSL2016PH2.APN23

MODEL

HLSL2016PH2

SHIP WEIGHT

6

CUBE

1.1

LIST PRICE BY FABRIC GRADE

1	2	3	4	5	6
\$309	\$333	\$357	\$381	\$412	\$443

NOTES:

- Chassis and drawer fronts woodgrains and solid laminates are specified separately (see SIF options below).
- File drawers accept hanging folders in letter or legal size.
- Multiple handle locations possible per customer preference.
- Seat cushions are available for low credenzas, floor credenzas, and mobile pedestals (specify separately).
- Storage accessory model HLSLDRWORG works with box doors.
- Standard box drawers operate on ball-bearing suspension with 70% extension. File drawers operate on ball-bearing suspension with 70% extension.
- Ships with one handle per drawer on all units.

! Locking units equipped with HON "One Key" interchangeable core removable locks. Keyed alike core must be ordered separately.

HOW TO SPECIFY**Select Model Number**

HLSL2030MCO

Select Chassis Laminate

See page 171

N

Select Drawer Front Laminate

See page 171

N

Select Pull Color

See page 171

T4

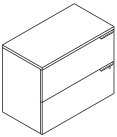
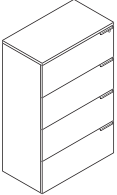
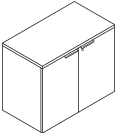
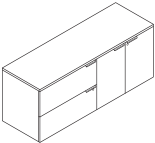
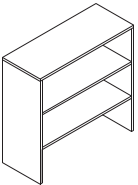

	DESCRIPTION	MODEL	SHIP WEIGHT	CUBE	L1 LIST	L2 UPCHARGES	
						CHASSIS	FRONTS
	2-Drawer Lateral Files 36"W x 24"D x 29½"H 36"W x 20"D x 29½"H	HLSL2436L2	305	29.8	\$1284	\$35	\$20
		HLSL2036L2	170	15.7	\$1152	\$30	\$20
	4-Drawer Lateral Files 36"W x 24"D x 57"H 36"W x 20"D x 57"H	HLSL2436L4	366	35.9	\$1826	\$45	\$30
		HLSL2036L4	204	18.3	\$1714	\$40	\$30
	Storage Cabinet 36"W x 24"D x 29½"H 36"W x 20"D x 29½"H	HLSL2436SC	150	18.3	\$972	\$35	\$20
		HLSL2036SC	147	15.7	\$913	\$30	\$20
	Lateral/Storage Cabinet Credenza 72"W x 24"D x 29½"H	HLSL2472LC	300	35.6	\$2590	\$45	\$30
	Bookcase Hutch (no doors) 36"W x 14"D x 35"H NOTES: Bookcase Hutch model works with Storage Cabinet and Lateral File models shown above. ! Specify: Chassis laminate only.	HLSL1436BH	125	3.7	\$702	\$20	N/A

NOTES:

- Ships with one handle per drawer on all units.
 - All models shown below are locking.
 - Chassis and drawer fronts woodgrains and solid laminates are specified separately (see SIF options below).
 - File drawers accept hanging folders in letter or legal size.
 - Multiple handle locations possible per customer preference.
 - Adjustable hex leveling glides allow floor-standing furniture to be easily leveled without lifting the unit; glides have 1/4" adjustable range.
- ! Locking units equipped with HON "One Key" interchangeable core removable locks. Keyed alike core must be ordered separately.







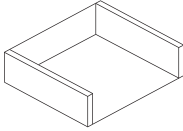

HOW TO SPECIFY

<p>Select Model Number</p> <p>See page 171</p> <p>HLSL2036L2 . N .</p>	<p>Select Chassis Laminate</p> <p>See page 171</p> <p>N .</p>	<p>Select Drawer Front Laminate</p> <p>See page 171</p> <p>Not specified for model HLSL1436BH</p> <p>N .</p>	<p>Select Pull Color</p> <p>See page 171</p> <p>Not specified for Bookcase Hutch model HLSL1436BH</p> <p>T 4</p>
---	--	---	---

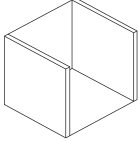
VOI® Laminate Storage Cubes

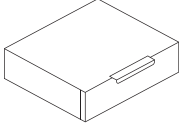
GSA SIN 33721

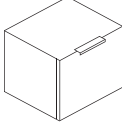
Icon Legend on page 19

	DESCRIPTION	MODEL	SHIP WEIGHT	CUBE	L1 LIST	L2/P2 UPCHARGES		
						CHASSIS	DOOR FRONT	PAINT
	Short Open Cube 15"W x 13"D x 4"H	HL S L154LSO	9 	1.4	\$147	\$10	N/A	\$8
	Tall Open Cube 15"W x 13"D x 12"H	HL S L1512LSO	16 	2.9	\$176	\$10	N/A	\$8
	Drawer Cube 15"W x 13"D x 4"H	HL S L154LSD	19 	1.4	\$221	\$10	\$5	\$8
	Cabinet Cube 15"W x 13"D x 12"H – Right Handed	HL S L1512LSCR	24 	2.9	\$221	\$10	\$5	\$8
	15"W x 13"D x 12"H – Left Handed	HL S L1512LSCL	24 	2.9	\$221	\$10	\$5	\$8

NOTES:

- 4"H and 12"H cubes attach to credenzas, worksurfaces, or wall mounted shelves.
- Configurable components are assembled using double-sided tape.
- Three 4"H cubes can be stacked to the height of one 12"H cube.

 Do not leave a gap wider than 15" between cubes while assembled with a shelf.

 Do not stack cube and shelf configurations higher than 30".

HOW TO SPECIFY

Select Model Number HL S SL154LSD .	Select Chassis Laminate See page 171 C .	Select Front Laminate See page 171 Not specified on HL S L154LSO and HL S L1512LSO C .	Select Paint Color See page 171 P3 upcharge (+ \$20) T1 .	Select Pull Color See page 171 Not specified on HL S L154LSO and HL S L1512LSO T1
--	---	--	---	---

	DESCRIPTION	MODEL	SHIP WEIGHT	CUBE	L1	L2
					LIST PRICE	UPCHARGE
	Shelves 30"W x 13"D	HL S LR1330	10 	1.3	\$187	\$10
	36"W x 13"D	HL S LR1336	12 	1.5	\$210	\$10
	45"W x 13"D	HL S LR1345	15 	1.9	\$228	\$10

NOTES:

- Use shelves in between cubes to create another layering element, if desired.

HOW TO SPECIFY

Select Model Number HL S LR1330 .	Select Laminate See page 171 C
--	---

QTY	DESCRIPTION	MODEL	LIST PRICE	PRICE EXTENSION
2	Cube Bundle A Short Open Cube 15"W x 13"D x 4"H	HLSL154LSO	\$147	\$294
HLSL15-SOO			TOTAL:	\$294

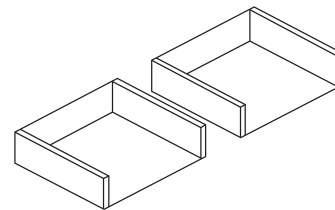

HLSL15-SOO

QTY	DESCRIPTION	MODEL	LIST PRICE	PRICE EXTENSION
3	Cube Bundle B Short Open Cube 15"W x 13"D x 4"H	HLSL154LSO	\$147	\$441
1	Tall Open Cube 15"W x 13"D x 12"H	HLSL1512LSO	\$176	\$176
HLSL15-SOOOLO			TOTAL:	\$617

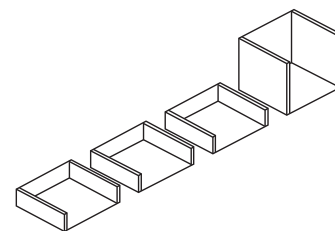

HLSL15-SOOOLO

QTY	DESCRIPTION	MODEL	LIST PRICE	PRICE EXTENSION
1	Cube Bundle C Short Open Cube 15"W x 13"D x 4"H	HLSL154LSO	\$147	\$147
1	Tall Open Cube 15"W x 13"D x 12"H	HLSL1512LSO	\$176	\$176
1	Drawer Cube 15"W x 13"D x 4"H	HLSL154LSD	\$221	\$221
1	Cabinet Cube, Right Handed 15"W x 13"D x 12"H	HLSL1512LSCR	\$221	\$221
HLSL15-SODLOC			TOTAL:	\$765

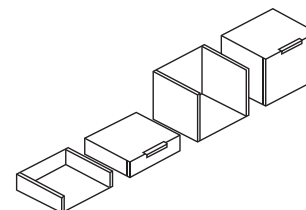

HLSL15-SODLOC

QTY	DESCRIPTION	MODEL	LIST PRICE	PRICE EXTENSION
2	Cube Bundle D Drawer Cube 15"W x 13"D x 4"H	HLSL154LSD	\$221	\$442
2	Cabinet Cube, Right Handed 15"W x 13"D x 12"H	HLSL1512LSCR	\$221	\$442
HLSL15-SDDLCC			TOTAL:	\$884

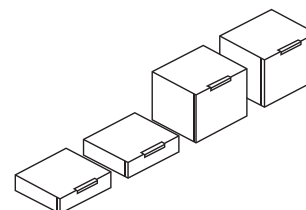

HLSL15-SDDLCC

QTY	DESCRIPTION	MODEL	LIST PRICE	PRICE EXTENSION
2	Cube Bundle E Drawer Cube 15"W x 13"D x 4"H	HLSL154LSD	\$221	\$442
2	Short Open Cube 15"W x 13"D x 4"H	HLSL154LSO	\$147	\$294
1	Tall Open Cube 15"W x 13"D x 12"H	HLSL1512LSO	\$176	\$176
1	Cabinet Cube, Right Handed 15"W x 13"D x 12"H	HLSL1512LSCR	\$221	\$221
HLSL15-SOODDLOC			TOTAL:	\$1,133

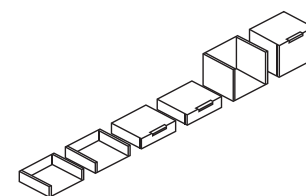

HLSL15-SOODDLOC

VOI® Laminate Storage Towers

GSA SIN 33721



Icon Legend on page 19

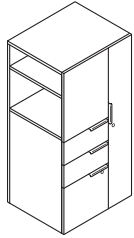

DESCRIPTION	MODEL	SHIP WEIGHT	CUBE	L1 LIST	L2 UPCHARGES	
					CHASSIS	FRONTS
24"W x 20"D Storage Tower — Right Hand Drawers, Left Hand Door						
24"W x 20"D x 50"H, Left	HLSLW045L	167	17.4	\$1919	\$50	\$35
24"W x 20"D x 65"H, Left	HLSLW046L	200	22.5	\$2188	\$55	\$35
24"W x 20"D Storage Tower — Left Hand Drawers, Right Hand Door						
24"W x 20"D x 50"H, Right	HLSLW045R	167	17.4	\$1919	\$50	\$35
24"W x 20"D x 65"H, Right	HLSLW046R	200	22.5	\$2188	\$55	\$35

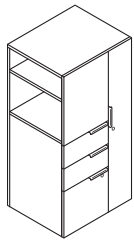

24"W x 24"D Storage Tower — Right Hand Drawers, Left Hand Door						
24"W x 24"D x 50"H, Left	HLSLW445L	200	20.7	\$2078	\$55	\$35
24"W x 24"D x 65"H, Left	HLSLW446L	240	27.8	\$2304	\$60	\$35
24"W x 24"D Storage Tower — Left Hand Drawers, Right Hand Door						
24"W x 24"D x 50"H, Right	HLSLW445R	200	20.7	\$2078	\$55	\$35
24"W x 24"D x 65"H, Right	HLSLW446R	240	27.8	\$2304	\$60	\$35

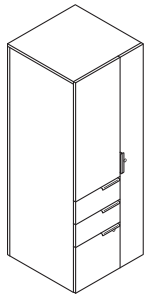

24"W x 24"D Personal Storage Tower						
24"W x 24"D x 65"H, Left	HLSLW446LP	250	27.8	\$2609	\$60	\$35
24"W x 24"D x 65"H, Right	HLSLW446RP	250	27.8	\$2609	\$60	\$35



DESCRIPTION	MODEL	SHIP WEIGHT	CUBE	LIST PRICE BY PAINT GRADE		
				P1	P2	P3
Worksurface to Tower Bracket Kit						
Bracket to attach storage towers or pedestal to worksurfaces.	HSTB2W1	4	0.6	\$76	\$89	\$100
NOTES: Can be used in place of end panel or O-leg to support worksurfaces.						
! Bracket cannot be used as a support when placing Stack-on Storage on worksurface over bracket. Must use two full-sized supports when using Stack-on Storage.						

NOTES:

- Use the worksurface to tower bracket kit to attach worksurfaces to Storage Towers models shown above.
- Chassis and drawer fronts woodgrains and solid laminates are specified separately (see SIF options below).
- File drawers accept hanging folders in letter or legal size.
- Wardrobe, middle box drawer and file drawer are locking.
- Standard box drawers operate on ball-bearing suspension with full extension. File, lateral, and wide box drawers operate on ball-bearing suspension with full extension.
- Ships with one handle per drawer on all units.
- Adjustable hex leveling glides allow floor-standing furniture to be easily leveled without lifting the unit; glides have 1/4" adjustable range.
- Wardrobe/storage cabinet includes coat rod.
- Wardrobes contain easy access side storage shelves.

! Locking units equipped with HON "One Key" interchangeable core removable locks. Keyed alike core must be ordered separately.

HOW TO SPECIFY

Select Model Number	Select Chassis Laminate	Select Drawer Front Laminate	Select Pull Color
See page 171	See page 171	See page 171	See page 171
HLSLW045L	N	N	T4



Icon Legend on page 19

Laminate Storage Towers

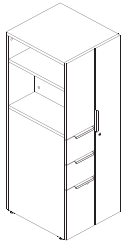

DESCRIPTION

MODEL

SHIP WEIGHT

CUBE

L1 LIST

**L2 UPCHARGES
CHASSIS FRONTS**

18"W x 20"D Storage Towers — Right Hand Drawers, Left Hand Door

18"W x 20"D x 50"H, Left
18"W x 20"D x 65"H, Left

HLSLW085L
HLSLW086L

139
167

13.4
17.3

\$1728
\$1973

\$45
\$50

\$35
\$35

18"W x 20"D Storage Towers — Left Hand Drawers, Right Hand Door

18"W x 20"D x 50"H, Right
18"W x 20"D x 65"H, Right

HLSLW085R
HLSLW086R

139
167

13.4
17.3

\$1728
\$1973

\$45
\$50

\$35
\$35



18"W x 24"D Storage Towers — Right Hand Drawers, Left Hand Door

18"W x 24"D x 50"H, Left
18"W x 24"D x 65"H, Left

HLSLW485L
HLSLW486L

167
200

15.8
21.5

\$1966
\$2191

\$50
\$55

\$35
\$35

18"W x 24"D Storage Towers — Left Hand Drawers, Right Hand Door

18"W x 24"D x 50"H, Right
18"W x 24"D x 65"H, Right

HLSLW485R
HLSLW486R

167
200

15.8
21.5

\$1966
\$2191

\$50
\$55

\$35
\$35

NOTES:

- Ships with one handle per drawer on all units.
- Chassis and drawer fronts woodgrains and solid laminates are specified separately (see SIF options below).
- File drawers accept hanging folders in letter or legal size.
- Standard box drawers operate on ball-bearing suspension with full extension. File and box drawers operate on ball-bearing suspension with full extension.
- Adjustable hex leveling glides allow floor-standing furniture to be easily leveled without lifting the unit; glides have 1/4" adjustable range.
- Wardrobe/storage cabinet includes coat rod.
- Wardrobes contain easy access side storage shelves.
- Wardrobe, middle box drawer and file drawer are locking.
- ! Locking units equipped with HON "One Key" interchangeable core removable locks. Keyed alike core must be ordered separately.
- ! Worksurface-to-tower bracket cannot be used as a support when placing Stack-on Storage on worksurface over bracket. Must use two full-sized supports when using Stack-on Storage.

HOW TO SPECIFY

<p>Select Model Number</p> <p>HL SLW085L</p>	<p>Select Chassis Laminate</p> <p>See page 171</p> <p>N</p>	<p>Select Door/Drawer Front Laminate</p> <p>See page 171</p> <p>N</p>	<p>Select Pull Color</p> <p>See page 171</p> <p>T4</p>
---	--	--	---

VOI® Laminate Storage Towers

GSA SIN 33721

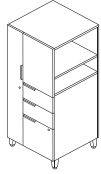

DESCRIPTION	MODEL	SHIP WEIGHT	CUBE	L1 LIST	L2 UPCHARGES	
					CHASSIS	FRONTS
Storage Towers, Right Hand Drawers, Left Hand Doors, Footed 20"W x 18"D x 54"H 24"W x 18"D x 54"H	HLSLW085LF	141	13.7	\$1784	\$45	\$35
	HLSLW485LF	169	16.2	\$2022	\$50	\$35
20"W x 24"D x 54"H 24"W x 24"D x 54"H	HLSLW045LF	169	17.8	\$1975	\$50	\$35
	HLSLW445LF	202	21.1	\$2134	\$55	\$35

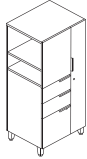

Storage Towers, Left Hand Drawers, Right Hand Doors, Footed 20"W x 18"D x 54"H 24"W x 18"D x 54"H	HLSLW085RF	141	13.7	\$1784	\$45	\$35
	HLSLW485RF	169	16.2	\$2022	\$50	\$35
20"W x 24"D x 54"H 24"W x 24"D x 54"H	HLSLW045RF	169	17.8	\$1968	\$50	\$35
	HLSLW445RF	202	21.1	\$2134	\$55	\$35

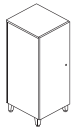

Storage Towers, One Door, Footed 18"W x 20"D x 46"H — Left Hand Door 18"W x 20"D x 46"H — Right Hand Door	HLSLW084LF	105	11.3	\$1283	\$35	\$25
	HLSLW084RF	105	11.3	\$1283	\$35	\$25



Storage Towers, One Door, Non-Footed 18"W x 20"D x 42"H — Left Hand Door 18"W x 20"D x 42"H — Right Hand Door	HLSLW084L	102	11.3	\$1227	\$35	\$25
	HLSLW084R	102	11.3	\$1227	\$35	\$25

NOTES:

- Use the worksurface to tower bracket kit to attach worksurfaces to Storage Towers models shown above.
- Chassis and drawer fronts woodgrains and solid laminates are specified separately (see SIF options below).
- File drawers accept hanging folders in letter or legal size.
- Wardrobe, middle box drawer and file drawer are locking.
- Standard box drawers operate on ball-bearing suspension with full extension. File, lateral, and wide box drawers operate on ball-bearing suspension with full extension.
- Ships with one handle per drawer on all units.
- Adjustable hex leveling glides allow floor-standing furniture to be easily leveled without lifting the unit; glides have 1/4" adjustable range.
- Wardrobe/storage cabinet includes coat rod.
- Wardrobes contain easy access side storage shelves.

! Locking units equipped with HON "One Key" interchangeable core removable locks. Keyed alike core must be ordered separately.

HOW TO SPECIFY

Select Model Number HLSLW085LF	Select Chassis Laminate See page 171 C	Select Drawer Front Laminate See page 171 C	Select Pull Color See page 171 T1	Select Foot Color See page 171 T1
--	---	--	--	--



DESCRIPTION	MODEL	SHIP WEIGHT	CUBE	L1 LIST	L2 UPCHARGES	
					CHASSIS	FRONTS
Box/File Pedestal, Footed 16"W x 20"D x 28½"H	HLSL2016FP2	65	5.8	\$850	\$20	\$10

NOTES:

- Ships with one handle per drawer on all units.
 - All models shown below are locking.
 - Chassis and drawer fronts woodgrains and solid laminates are specified separately (see SIF options below).
 - File drawers accept hanging folders in letter or legal size.
 - Multiple handle locations possible per customer preference.
 - Adjustable hex leveling glides allow floor-standing furniture to be easily leveled without lifting the unit; glides have 1/4" adjustable range.
- ⓘ Locking units equipped with HON "One Key" interchangeable core removable locks. Keyed alike core must be ordered separately.

HOW TO SPECIFY

<p>Select Model Number</p> <p>H L S L 2 0 1 6 F P 2</p>	<p>Select Chassis Laminate</p> <p>See page 171</p> <p>C</p>	<p>Select Drawer Front Laminate</p> <p>See page 171</p> <p>C</p>	<p>Select Pull Color</p> <p>See page 171</p> <p>T 1</p>	<p>Select Foot Color</p> <p>See page 171</p> <p>T 1</p>
--	--	---	--	--

VOI® Laminate Bookcases

GSA SIN 33721



Icon Legend on page 19

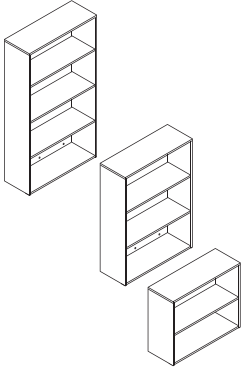

DESCRIPTION	MODEL	SHIP WEIGHT	CUBE	LIST PRICE BY LAMINATE GRADE	
				L1	L2
Bookcase 36"W x 13"D x 29½"H, 2-Shelf	HLSL1336B2	90	10.7	\$558	\$573
36"W x 13"D x 50"H, 3-Shelf	HLSL1336B3	122	17.3	\$719	\$739
36"W x 13"D x 65"H, 4-Shelf	HLSL1336B4	156	22.2	\$845	\$870

NOTES: Bookcases available in 2, 3 and 4 shelf models. Adjustable glides allow bookcases to be easily leveled. Glides have 1/4" of adjustability.

HOW TO SPECIFY

Select Model Number

H L S L 1 3 3 6 B 2 .





Select Laminate

See page 171

N

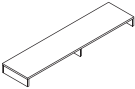

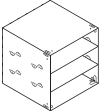
Icon Legend on page 19

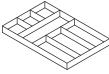
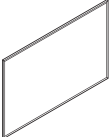
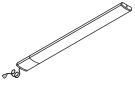
	DESCRIPTION	MODEL	SHIP WEIGHT	CUBE	L1 LIST PRICE	L2 UPCHARGE
 	Layering Shelf 72"W x 14½"D x 5½"H 60"W x 14½"D x 5½"H	HLSL1472LS HLSL1460LS	50 39	4.6 1.3	\$435 \$364	\$10 \$10
	NOTES: Layering shelf works with lower credenzas to provide additional storage areas. For additional information see page 844. ! Layering Shelves cannot be stacked. ! Cannot add a hutch on top of a layering shelf.					
 	Storage Cube 12"W x 12"D	HLSL1212	1.0	0.3	\$294	
	NOTES: For additional information see page 846. SPECIFYING EXAMPLE: HLSL1212.P8S					
	Drawer Organizer 12"W x 14½"D x 1½"H	HLSLDRWORG	1.0	0.5	\$156	
	NOTES: For additional information see page 846. SPECIFYING EXAMPLE: HLSLDRWORG.P8F					
	48"W x 31"H	HLSL4831MB	44.0	3.4	\$664	
	NOTES: No specification required. For additional information see page 847.					
 OPEN MARKET	LED Task Lights 17" LED Light with Power Supply (Single) 31" LED Light with Power Supply (Single)	HLED17AS HLED31AS	1.2 Ⓢ 1.5 Ⓢ	0.05 0.09	\$420 \$565	
	17" LED Light with Power Supply for Daisy-chain (Starter) 31" LED Light with Power Supply for Daisy-chain (Starter)	HLED17A HLED31A	1.0 Ⓢ 1.4 Ⓢ	0.05 0.09	\$462 \$620	
	17" LED Light with 8" Jumper Cord for Daisy-chain (Follower) 31" LED Light with 8" Jumper Cord for Daisy-chain (Follower)	HLED17AUO HLED31AUO	1.0 Ⓢ 1.0 Ⓢ	0.03 0.05	\$377 \$502	
	Undercabinet Occupancy Sensor with 1" End to End Connector	HLEDOSA	0.2 Ⓢ	0.01	\$89	
	NOTES: To use the daisy chain application, must start with model HLED17A or HLED31A. No finish specification required. Attaches magnetically to underside of overhead storage, or attaches with provided screws or double-sided tape. Occupancy sensor attaches to a single or starter LED light and will automatically turn the light off after no motion is detected for 30 minutes. Just like all the LED light models, the occupancy sensor features a soft-touch on/off switch. LED task lights have a lifetime of 50,000 hours and have a dimmer feature that allows the user to adjust the amount of light output. For additional information see page 842.					

HOW TO SPECIFY

Select Model Number HLSL1472LS	Select Laminate See page 171 N
-----------------------------------	--------------------------------------

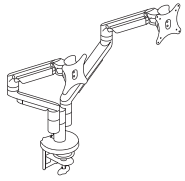
**DESCRIPTION****MODEL****SHIP WEIGHT****CUBE****LIST PRICE****Dual Dynamic Monitor Arm**

- 150° of rotation at base with optional 360° rotation.
- Arms extend 22" and retract up to 3".
- Monitor mount rotates 180° and tilts +/-30°.
- Monitor can be rotated from landscape to portrait position.

HMASD

17.0

1.1

\$750

Arms hold monitors from 6.2-18 lbs. Optional counterweight HPACW available to support monitors as low as 5 lbs. (see page 827).

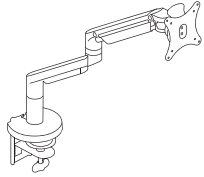
**Single Dynamic Monitor Arm**

- 180° of rotation at base with optional 360° rotation.
- Arms extend 22" and retract up to 3".
- Monitor mount rotates 180° and tilts +/-30°.
- Monitor can be rotated from landscape to portrait position.

HMAST

11.5

0.8

\$390

Arms hold monitors from 6.2-18 lbs. Optional counterweight HPACW available to support monitors as low as 5 lbs. (see page 827).

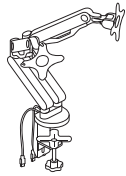
**Dual Monitor Arm with 2 USB Ports****HBDMAUSB**

41.9

2.6

\$441

NOTES: Easy adjustment. Height adjusts to 17" tall. Monitor tilt and swivel capability. Enclosed cable management. Grommet or desktop mounting. Clean appearance. In some applications the Monitor Arms may extend 12 or more inches into the worksurface. For additional information see page 825. **HON 5-Year Limited Warranty.**

No specification needed.

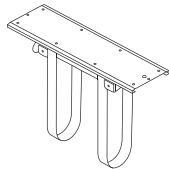
**360° Swivel CPU Holder with Adjustable Straps****HCPUI**

7.0

0.2

\$243

- Supports CPUs 3¾" wide up to 64" perimeter and holds up to 75 lbs.
- 360° rotation.
- Ships complete and includes necessary mounting hardware and instruction sheet.

Available in Black only, no specification needed.

SIN 33721**NOTES:**

- For additional information see pages 825-827.

Monitor Arms

- Arms fold back to post to allow more desktop room.
- Arms feature double extension, allowing 20"+ of back and forth movement.
- Cable management on both pole and arm assemblies.
- Counterbalance adjustment provides stability for monitors up to 17.6 lbs per arm.
- Made of high quality aluminum alloy material.
- See pages 825-826 for additional monitor arm models.

HOW TO SPECIFY**Select Model Number****HMASD****Select Finish***Specify for models HMASD and HMAST only***SVR** Silver
BLK Black**SVR**



Icon Legend on page 19

DESCRIPTION

MODEL SHIP WEIGHT CUBE LIST PRICE

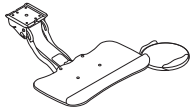

Sit to Stand Arm with Keyboard

- Sit to stand application.
- No knob or lever for adjustment, simply lift into place.
- One-hand tilt adjustment for maximum flexibility.
- For use on surfaces 24" or deeper.
- Height adjustment without levers.
- +10°/-20° tilt adjustment.
- Height adjustment 12½" (7" above and 5½" below).
- Tilt and swivel mouse surface with gel palm rest.
- Detachable palm rest.
- Mouse pad can mount right or left.

H2516 * 17 \$ 1.6 \$618

! Black finish only, no specification needed.

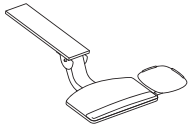

Articulating Arm with Convertible Keyboard

- 21" glide track.
- Lift and lock height adjustment.
- Height adjustment 7" (2½" above and 4½" below track).
- Release handle for independent tilt adjustment.
- Tilt: +/-15°.
- Independent tilt and swivel mousing platform.
- Positions platform flush with worksurface.
- 360° rotation.
- Mouse can be used in-line, over, or forward at platform height or above.
- Mouse can be placed at platform height or above height.
- Left or right handed mousing; no tools required.
- Detachable palm rest.
- Cord management clips included.

H2107 * 16 \$ 1.3 \$529

! Black finish only, no specification needed.

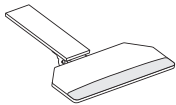

Articulating Arm with Keyboard

- 17" glide track.
- Spring assisted.
- Height adjustment 6¼" (1¼" above and 5" below track).
- Tilt: +10°/-15°.
- 25" cut corner platform.
- Accommodates keyboard and mouse on same level.
- Detachable palm rest.
- Cord management clips included.

H1706 * 16 \$ 1.4 \$493

! Black finish only, no specification needed.

NOTES:

- For additional information see page 829.

* De-emphasized.

Voi® Worksurface with Accessory Selection Guide			Grommet & External Channel			
Accessory Type	Model	Clearance	20"D	24"D	30"D	36"D
CPU Holder	HCPU	13½"	N	Y	Y	Y
Keyboard Tray	H2516	24"	N	N	N	Y
Keyboard Tray	H2107	21¼"	N	N	Y	Y
Keyboard Tray	H1706	17¼"	N	N	Y	Y
Laminate Center Drawer	H1522	18½"	N	N	Y	Y
Laminate Center Drawer	H1526	18½"	N	N	Y	Y
Metal Center Drawer	HD2	20¼"	N	N	Y	Y
Metal Center Drawer	HD8	20¼"	N	N	Y	Y
Keyboard Tray	H4022	17"	N	N	Y	Y
Keyboard Tray	HE4022	17"	N	N	Y	Y
Keyboard Tray	H4028	15"	N	Y	Y	Y
Keyboard Tray	H4029	15"	N	Y	Y	Y

HOW TO SPECIFY

Select Model Number

H 2 5 1 6

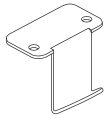

OPEN MARKET

**DESCRIPTION**

Back Pack Hook (10 per carton)
12"W x 14½"D x 1½"H

MODEL**HCLA65****SHIP WEIGHT**

10 Ⓞ

CUBE

0.1

LIST PRICE**\$94**

NOTES: Assembly: attaches to bottom of desk with (2) screws, included. For additional information see page 846.

! Available in Platinum Metallic finish only, no specification needed.

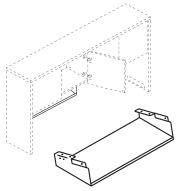
**Hanging Paper Shelf**

28½"W x 11¼"D x 4¾"H

HHPS1

7

2.9

\$198

NOTES: Attaches quickly and easily (screws included). Maximizes worksurface space; de-clutters desktop while placing priority communications and active project folders within easy reach. Angled design allows contents to be distinguished at a glance. Mixed material styling features strong painted metal frame with a frosted shelf.

Attaches quickly and easily to laminate stack-on and wall mount storage models (except the 36"W Voi® overhead hutch with O-legs or panel mount brackets). Not for use with 38000 Series™ and Systems.

For additional information see page 824.

Specify: Model.Paint

SPECIFYING EXAMPLE: HHPS1.T1

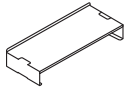
**Desktop Paper Shelf**

28½"W x 11½"D x 5"H

HDPS1

7

2.9

\$198

NOTES: Desktop Paper Shelf and Storage Terrace include protective, non-slip pads on the base. Paper Shelf can stack two-high. Organizer shelf provides a place and space for work-in-process and piling to keep work-surfaces neat and tidy. Convenient, scalable design with interlocking side supports allow two units to be stacked and integrated. Durable painted metal frame with a frosted shelf; mixed material styling matches hanging paper shelf.

Can also be used inside select overhead storage, including the following stack-on with clearance and hinged door models: 10500 and Valido 36", 42", 66", 72", 78"W and 10700 68½"W.

For additional information see page 824.

Specify: Model.Paint

SPECIFYING EXAMPLE: HDPS1.T1

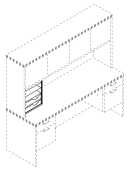

Not available in two-tone laminates

Vertical Paper Manager

14¾"W x 10¾"D x 19¼"H

HLVPM1

27

2.8

\$327

NOTES: Keeps papers, files, and books neatly organized and within easy reach from a seated position. Designed for desk, credenza, and return tops. Fits under stack-on storage models. Two pullout drawers and three fixed shelves. Not available in pattern laminate colors. Ships fully assembled. For additional information see page 844.

! When used in conjunction with wall mounted storage cabinets, the top of the wall mounted storage cabinets must be positioned a minimum of 68¾" above the floor.

SPECIFYING EXAMPLE: HLVPM1.N

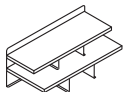

Not available in two-tone laminate

**Desktop Storage Terrace**

26½"W x 12½"D x 10½"H

HLDST1

24

1.1

\$306

NOTES: Keeps work-in-process, priority files, loose pages, and mail neatly organized and in view. Mixed material design comprised of sturdy laminate shelves with metal back and support panels. Not available in two-tone laminate combination or pattern laminate colors. Choose from Platinum Metallic (T1), Black (P), and Charcoal (S) for the metal components.

Sized to fit in stack-on and wall mounted storage cabinets in 10500, 10700, Valido, 94000, and 38000 Series. Fits in Voi stack-on and overhead cabinets except for 48"W or smaller sliding door models. For additional information see page 844.

Specify: Model.Laminate.Paint









SPECIFYING EXAMPLE: HLDST1.N.T1

HOW TO SPECIFY

Select
Model Number

H C L A 6 5

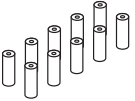

	DESCRIPTION	MODEL	SHIP WEIGHT	CUBE	LIST PRICE
 Refer to page 106 for Center Drawer compatibility information SIN 33721 	Angled Wood Center Drawer 26" x 15 ³ / ₈ " 22" x 15 ³ / ₈ " NOTES: Specify laminate for drawer. Ideal for pens, pencils and other miscellaneous storage. Feature ball-bearing slide suspension. For additional information see page 832.	H1526 H1522	12  11 	1.2 1.1	\$198 \$184
	Polymer Center Drawer <ul style="list-style-type: none"> • Color: Black. • Material: ABS. • Opening Requirements: 23"W x 16¹/₄"D x 2"H. • Retracts on 16" ball-bearing slides. • Can be used on worksurfaces with Coordinate™ Height Adjustable Bases as long as it is attached with spacer model HKBS. • Can store up to 25 lbs. NOTES: For additional information see page 833.  Black finish only, no specification needed.	HCD1	7	0.5	\$108
  OPEN MARKET	Keyboard Spacer <ul style="list-style-type: none"> • For use when attaching a keyboard tray to Coordinate™ and Voi® or Systems Worksurface with an external channel. • The kit includes ten cylinder spacers and ten screws. • Spacers are 3/4"W x 2¹/₈"H. • Specify one kit per keyboard tray. NOTES: For additional information see page 828.	HKBS	1 	0.8	\$90

HOW TO SPECIFY

Select Model Number

H
C
D
1

**DESCRIPTION**
Articulating Desk Lamp
Articulating Desk Lamp w/ Occupancy Sensor

- Color: Matte Silver.
- Full-range dimming from 10% to 100%.
- Designed for 50,000 hours of life.
- Occupancy sensor is built into the head of the lamp and will automatically shut the lamp off after 6 minutes of undetected movement.
- Base swivel is 180 degrees.
- Uses only 5 watts of energy.
- Light comes with a silver 9' 4" power cord.
- Base diameter is 7.5".
- 3500K Color Temperature.
- 80 Color Rendering Index.
- TAA Compliant.

MODEL SHIP WEIGHT CUBE LIST PRICE

HLED1	1.2 Ⓢ	6.5	\$402
HLED1OC	1.2 Ⓢ	6.5	\$490

**Task Desk Lamp**

- Color: Brushed Nickel.
- Full-range dimming from 10% to 100%.
- Designed for 50,000 hours of life.
- Lamp is 15.83" tall.
- Desk lamp does not articulate at base. The pivoting head provides custom positioning, as it can be twisted 360 degrees.
- Uses only 5 watts of energy.
- Light comes with a silver 9' 4" power cord.
- Base diameter is 6.7".
- 3500K Color Temperature.
- 80 Color Rendering Index.
- TAA Compliant.

HLED2	0.7 Ⓢ	3.0	\$348
--------------	-------	-----	--------------

NOTES:

- For additional information see page 841.

HOW TO SPECIFY

Select
Model Number

H L E D 1

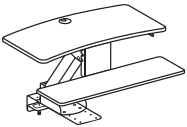
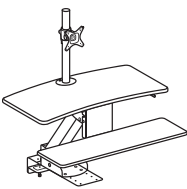
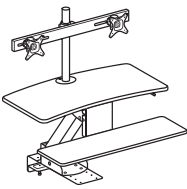
	DESCRIPTION	MODEL	SHIP WEIGHT	CUBE	LIST PRICE
	<p>Coordinate™ Portable Desktop Riser 31"D x 5"-16½"H x 35"W</p> <p>NOTES: Available in Black (BLK) or White (WHT) finish. Desktop riser dimensions (without keyboard tray): 22"D x 5"-16½"H x 35"W. Keyboard tray dimensions: 9"D x 30"W. Max loading capacity is 33 lbs for the desktop riser surface and 4 lbs for the keyboard tray. Easily transition from seated to standing positions throughout the workday. Sits atop an existing desk to create sit-to-stand functionality by raising the computer. Includes keyboard tray and surface for computer monitors. HON 5-Year Limited Warranty.</p> <p>⚠ Not intended for use on mobile workstations.</p>	HBXRISER	54	4.1	\$619
	<p>Coordinate™ Mounted Desktop Riser</p> <p>NOTES: Does not include a monitor arm and is suitable for laptops and/or monitors on their original stands.</p> <p>⚠ No specification needed.</p>	HS1100	60 Ⓢ	3.2	\$664
	<p>Coordinate™ Mounted Desktop Riser with Single Monitor Arm</p> <p>NOTES: Includes a monitor arm for a single monitor.</p> <p>⚠ No specification needed.</p>	HS1101	62 Ⓢ	3.2	\$777
	<p>Coordinate™ Mounted Desktop Riser with Dual Monitor Arm</p> <p>NOTES: Includes a monitor arm for dual monitors.</p> <p>⚠ No specification needed.</p>	HS1102	63 Ⓢ	3.2	\$883

NOTES FOR HS1100, HS1101, HS1102:

- These products are designed to allow the user to transition from seating position to standing position throughout the workday.
- Gas-assist lever-operated mechanism with positive stop.
- Clamp mount compatible with worksurfaces depths of 20"-30". 20" is for systems only.
- Clamp requires 3.5" of clearance along back edge of worksurface.
- Black seamless worksurfaces.
- Silver powder coated metal components.
- Lowers below worksurface level on 24" and 30"D worksurfaces.
- All models contain a large primary worksurface and a smaller keyboard / mouse surface.
- Beveled edges for sleek appearance and comfort while typing.
- Monitor arms include height, width, and swivel adjustment.
- For additional information see page 838.

- Not for use under overhead storage, with flush mounted modesty panels, or worksurfaces thinner than 1".

⚠ Not recommended for use on mobile (castered) worksurfaces.

MOUNTING AND COMPATIBILITY FOR HS1100, HS1101, HS1102:

- This product is intended to be installed on commercial-grade worksurfaces in good condition.
- Compatible with freestanding worksurfaces 24"-30"D or panel-supported worksurfaces 24"-30"D.
- Not for use on mobile worksurfaces.

Clamp Mount

Use when 3.5" minimum overhang is available

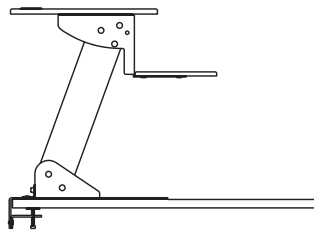

Screw Mount

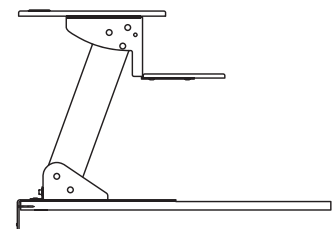

Use when no overhang is available. Worksurface must be minimum 1" thick.



HOW TO SPECIFY

<p>Select Model Number</p> <p>HBXRISER.</p>	<p>Select Finish</p> <p>BLK Black WHT White</p> <p>BLK</p>
--	---

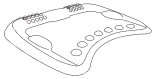
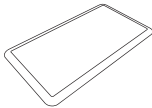
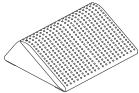

	DESCRIPTION	MODEL	SHIP WEIGHT	CUBE	LIST PRICE
	Rectangle Wobble Board — Anti-Fatigue Mat 18"D x 3"H x 22½"W ⓘ Available in Black (T) finish ONLY. Recommended weight capacity not to exceed 250 pounds. HON 5-Year Limited Warranty. SPECIFYING EXAMPLE: HVL981.T	HVL981	10.0 ⓘ	0.9	\$120
	Round Wobble Board — Anti-Fatigue Mat 18½"D x 2½"H x 18½"W ⓘ Available in Black (T) finish ONLY. Recommended weight capacity not to exceed 250 pounds. HON 5-Year Limited Warranty. SPECIFYING EXAMPLE: HVL982.T	HVL982	5.8 ⓘ	0.6	\$102
	Ergonomic Anti-Fatigue Mat 25"D x 2¾"H x 29⅞"W ⓘ Available in Black ONLY. No specification needed. SPECIFYING EXAMPLE: HBEAFM1	HBEAFM1	7.0	1.4	\$219
	Rectangle Anti-Fatigue Mat 20"D x ¾"H x 36"W ⓘ Available in Black ONLY. No specification needed. SPECIFYING EXAMPLE: HBAFM2036	HBAFM2036	5.4	0.4	\$100
	Footrest — Anti-Slip Cover 13¾"D x 5½"H x 16"W ⓘ Available in Black (T) finish ONLY. Recommended weight capacity not to exceed 250 pounds. HON 5-Year Limited Warranty. SPECIFYING EXAMPLE: HVL991.T	HVL991	7.0 ⓘ	0.9	\$82

HOW TO SPECIFY

Select
Model Number

H V L 9 8 1 .

Select
Finish

T Black



T



Icon Legend on page 19

Software Electrical Components

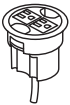
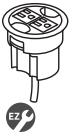

	DESCRIPTION	MODEL	SHIP WEIGHT	CUBE	LIST PRICE
	<p>Power Hub, 3" Grommet Mount, 6' Cord</p> <ul style="list-style-type: none"> Fits in 3" round grommet holes Field installed with Plug-and-play ease Two grounded AC power outlets Includes 6' cord with three-prong plug <p>NOTES: For additional information see page 848.</p> <p>ⓘ Available in Black only. Specify X when ordering. Example: HGRMTAC.X.</p>	HGRMTAC	1.3	0.2	\$111
	<p>3" Round Power Grommet - 2 Outlets, 10' Cord</p> <ul style="list-style-type: none"> Includes 10' cord with three-prong plug. Fits in 3" round grommet holes on the following product lines: Coordinate, Huddle, Motivate, all laminate and veneer casegoods series, and Systems Worksurfaces. Two grounded AC power outlets. Field installed with Plug-and-play ease. <p>NOTES: Power Modules will also work with standing-height applications for 10500 Series™ and Voi® desks. Optional Memory Control allows preset worksurface heights for consistency. Ships separately. Dynamic load capacity when worksurface is moving is 300 lbs.</p> <p>ⓘ Available in black finish only, no specification needed.</p>	HGRMTAC2	1.5	0.2	\$148
	<p>Power/USB Hub, 3" Grommet Mount</p> <ul style="list-style-type: none"> One grounded AC power outlet with 2 USB ports. Two cord pass-through holes in cap. Includes 6' cord with three-prong plug. Field installed; easy plug-and-play. UL Listed. <p>NOTES: For additional information see page 848.</p> <p>ⓘ Available in black only (no color designation so use .X - Specify: HGRMTUSB2.X).</p>	HGRMTUSB2	1.3	0.2	\$224
	<p>Data Grommet</p> <p>Blank grommet kit that includes adapters for a variety of manufacturers jacks and couplers.</p> <ul style="list-style-type: none"> Fits in existing 3" round grommet housing <p>NOTES: For additional information see page 848.</p> <p>ⓘ Available in Black only. Specify P when ordering. Example: HGRMTDATA.P.</p>	HGRMTDATA	0.2	0.2	\$19

SIN 33721

HOW TO SPECIFY

Select Model Number

H	G	R	M	T	A	C
---	---	---	---	---	---	---



OPEN MARKET

DESCRIPTION**O-Leg Cord Clips**

Clips for 28½" Worksurface O-Legs — 8-Pack
Clips for Stack-on Storage, Hutch and Layering O-Legs — 4-Pack

MODEL

HWMCLIPLG
HWMCLIPSM

SHIP WEIGHT

0.8 **Ⓢ**
0.5 **Ⓢ**

CUBE

0.1
0.1

LIST PRICE

\$99
\$65

NOTES: Wire clips work with 7" Low Credenza O-leg and 29"H Support O-leg. Wire clips also work with the 50" and 65" Hutch O-legs. For additional information see page 852.

⚠ Available in frosted plastic material only.

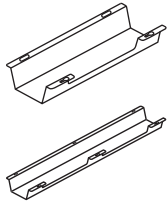
**Cable Management Troughs**

17"W — Single
17"W — 10-Pack
36"W — Single
36"W — 10-Pack

HCTROUGH17
HCTROUGH1710
HCTROUGH36
HCTROUGH3610

2.7 **Ⓢ**
14.0 **Ⓢ**
4.9 **Ⓢ**
30.0 **Ⓢ**

0.5
0.5
0.9
0.9

\$67
\$620
\$113
\$1045

- Cable management troughs ship flat packed.
- The troughs attach to underneath the worksurface with screws.
- The 17"W has one wire access cut out on the user side. The 36" has two wire access cut outs. These cut outs give users access to inside the trough without having to detach it from the worksurface.
- Color: Graphite.
- Material: Metal.
- TAA Compliant.

NOTES: For additional information see page 852.

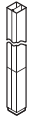
**Power Pole — w/o Receptacles**

10'5"

HH870070

14.0

0.5

\$429

⚠ Specify paint; not available in Putty (L), Platinum Metallic (T1), and Champagne Metallic (T4).

Specify paint color for
HH870070, not available in
Putty

**Field Installable Grommet**

HFLDGRMT3

0.1 **Ⓢ**

0.3

\$32

- Intended for use in tops and end panels to route/hide cords and in modesty panels to facilitate reaching wall electrical outlets.
- Grommet is field installable.
- Grommet shape is round.
- Includes grommet cap and sleeve.
- Grommet outside dimensions measure 3½" diameter and includes two cord access holes.
- Grommet sleeve measures 3" O.D. x 1" thick.
- Includes instructions to locate grommet position for desks, credenzas, returns and bridges.

NOTES: For additional information see page 848.

- ⚠ Black Finish
- ⚠ Requires a 3" diameter hole saw and drill for installation (not included).
- ⚠ Not for use with credenzas, pedestals, laterals or towers.



HOW TO SPECIFY

Select
Model Number

HWMCLIPLG

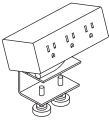
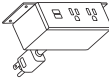
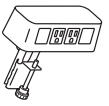
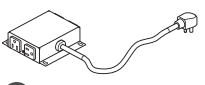

Icon Legend on page 19

	DESCRIPTION	MODEL	SHIP WEIGHT	CUBE	LIST PRICE
 Model HPWRMOD3WC shown	Power Modules				
	3 Receptacles with Worksurface Clamp	HPWRMOD3WC	2.3 Ⓢ	0.2	\$307
	3 Receptacles with Under-Worksurface Mounting Bracket	HPWRMOD3UWM	2.3 Ⓢ	0.2	\$307
	2 Receptacles 2 USB with Worksurface Clamp	HPWRMOD2WC	2.3 Ⓢ	0.2	\$491
 Model HPWRMOD2UWM shown	2 Receptacles 2 USB with Under-Worksurface Mounting Bracket	HPWRMOD2UWM	2.3 Ⓢ	0.2	\$491
	<ul style="list-style-type: none"> • 6' power cord with standard three-prong plug. • Under-worksurface mounting bracket models work with any top that has a 5" x 5" square clearance. • Worksurface clamp models work on any top with a 4" overhang. • UL Listed. ⓘ Color finish coordinates with HON's Charcoal or White. Specify <i>STRM</i> for Storm or <i>SNW</i> for Snow when ordering. Example: <i>HPWRMOD3WC.STRM</i> .				
	Power & Data Center				
	2 Receptacles 2 Data Accessory	HCOMDOME2	2.5 Ⓢ	0.2	\$293
	<ul style="list-style-type: none"> • Standard with two receptacles and openings for two data ports. • 6' power cord with standard three-prong plug. • Fits on any worksurface with a 4" overhang. • UL Listed. ⓘ Color finish coordinates with HON's Loft. Specify <i>LOFT</i> when ordering. Example: <i>HCOMDOME2.LOFT</i> .				
 	Under Worksurface Power Module — 4 Outlets, 10' Cord	HPWRMOD2	1.5	0.2	\$401
	<ul style="list-style-type: none"> • Includes 10' cord with three-prong plug. • Fits in cable management troughs. See page 232. • 4 outlets on side create easy access. NOTES: Power Modules will also work with standing-height applications for 10500 Series™ and Voi® desks. ⓘ Available in black finish only, no specification needed.				
	Vertebrae	HMPVWM28	3.0	0.3	\$221
	NOTES: 30"H x 3 3/8"W x 1 1/2"D. Ships unassembled. ⓘ Clear finish. Specify "X" for finish option. SPECIFYING EXAMPLE: HMPVWM28.X				

NOTES:

- For additional information see pages 849 and 852.

HOW TO SPECIFY

Select Model Number

H	P	W	R	M	O	D	3	W	C
---	---	---	---	---	---	---	---	---	---

NOTES

10500 SERIES™



10500 Series™ Workstation with Workwall shown with Ignition® Seating.

10500 SERIES™

Endlessly adaptable and unexpectedly affordable, our 10500 Series offers truly lasting value. The versatile design and options give you an even wider range of layout possibilities and the flexibility to maximize footprints — even smaller ones. And with more ways to customize your personal storage, the 10500 Series simply gives you more for less.



FEATURES

- The 10500 Series' fresh aesthetic includes **airy H- or O-legs and frosted modesty panels.**
- Available in **25** durable mix-and-match laminates, including new textured styles.
- With so many convenient and compact storage options, even the smallest footprints feel big.
- The versatile 10500 Series™ offers a variety of components to accommodate any size workspace.
- Support today's healthy work styles by offering the choice of sitting or standing while working, with storage options that fit your needs.

10500 SERIES™ ORDERING INFORMATION

LAMINATE TOP, CHASSIS, AND WORKSURFACES

L1 LAMINATES CODES

Woodgrain

◆ Bourbon Cherry	H
◆ Cognac	COGN
◆ Florence Walnut	LFW1
◆ Harvest	C
◆ Kingswood Walnut	LK11
◆ Mahogany	N
◆ Mocha	MOCH
◆ Natural Maple	D
◆ Pinnacle	PINC
◆ Shaker Cherry	F
◆ Sterling Ash	LSA1

Solid

◆ Black	P
◆ Charcoal	S
◆ Designer White	LDW1
◆ Loft	LOFT

Patterned Top

◆ Grey Tigris	L6
◆ Sheer Mesh	A5
◆ Silver Mesh	B9
◆ Canyon Zephyr	K9
◆ Desert Zephyr	K8

L2 LAMINATES CODES

Woodgrain

◆ Lowell Ash	LLA1
◆ Natural Recon	LNRI
◆ Phantom Ecreu	LPE1
◆ Portico Teak	LPT1
◆ Skyline Walnut	LSW1

EDGE BAND

EDGE BAND COLORS CODES

Woodgrain

◆ Bourbon Cherry	H
◆ Cognac	COGN
◆ Florence Walnut	FW
◆ Harvest	C
◆ Kingswood Walnut	KI
◆ Lowell Ash	DL
◆ Mahogany	N
◆ Mocha	MOCH
◆ Natural Maple	D
◆ Natural Recon	NR
◆ Phantom Ecreu	PE
◆ Pinnacle	PINC
◆ Portico Teak	DP
◆ Shaker Cherry	F
◆ Skyline Walnut	SW
◆ Sterling Ash	SA

Solid

◆ Black	P
◆ Charcoal	S
◆ Designer White	DW
◆ Loft	LOFT

10500 SERIES™ MOBILE TABLES

PAINTS CODES

P1

◆ Black	P
◆ Brownstone	P7D
◆ Charcoal	S
◆ Designer White	PJW
◆ Fossil	P28
◆ Greige	T5
◆ Loft	LOFT
◆ Muslin	T3
◆ Titanium	P8T

P2

◆ Champagne Metallic	T4
◆ Platinum Metallic	T1
◆ Silver	PR6

H-LEGS, O-LEGS, POST LEGS, STORAGE CUBE

PAINTS CODES

P1

◆ Black	P
◆ Brownstone	P7D
◆ Charcoal	S
◆ Designer White	PJW
◆ Fossil	P28
◆ Greige	T5
◆ Loft	LOFT
◆ Muslin	T3
◆ Shadow*	SHDW
◆ Titanium	P8T

P2

◆ Champagne Metallic	T4
◆ Platinum Metallic	T1
◆ Silver	PR6
◆ Solar Black	P8X

P3

◆ Atom	P8S
◆ Blossom	P8K
◆ Bullseye	PJF
◆ Cabernet	P7T
◆ Conifer	P8H
◆ Ember	P8P
◆ Ion	P8N
◆ Iris	P8J
◆ Krypton	P8F
◆ Regatta	P8M
◆ Succulent	P8A

◆◆◆ For lead time information see page 19.

* De-emphasized

Patterned Top

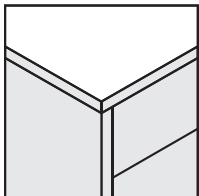

Edgeband Around Top / Laminate Chassis

- Edgebanding on patterned laminates matches the laminate **chassis** selected.
- Patterned top laminates are available with the following edgeband laminate selection: C, COGN, D, F, FW, H, KI, DW, MOCH, N, P, PINC, SA, and S.
- For 10500 Series™ worksurface models, the finish specification options include matching the top and edgeband colors or choosing a two-tone combination.

LAMINATE DESKS

SPECIFY: Model Number.
Laminate

EXAMPLE: H105413.NN

WORKSURFACES

SPECIFY: Model Number.
Top Laminate
Edgeband

- All specifications in this publication are based on the latest product information available at the time of print.

! Tops with a patterned color are not available with a matching edgeband.

10500 SERIES™ ORDERING INFORMATION

TWO-TONE LAMINATE TOP / CHASSIS

L1 LAMINATES	CODES
Two-Tone Top/Chassis	
◆ Black/Charcoal	PS
◆ Black/Designer White	PLDW1
◆ Black/Loft	PLOFT
◆ Bourbon Cherry/Black	HP
◆ Bourbon Cherry/Charcoal	HS
◆ Bourbon Cherry/Designer White	HLDW1
◆ Bourbon Cherry/Loft	HLOFT
◆ Charcoal/Black	SP
◆ Charcoal/Designer White	SLDW1
◆ Charcoal/Loft	SLOFT
◆ Cognac/Black	COGNP
◆ Cognac/Charcoal	COGNS
◆ Cognac/Designer White	COGNLDW1
◆ Cognac/Loft	COGNLOFT
◆ Designer White/Black	LDW1P
◆ Designer White/Bourbon Cherry	LDW1H
◆ Designer White/Charcoal	LDW1S
◆ Designer White/Cognac	LDW1COGN
◆ Designer White/Florence Walnut	LDW1LFW1
◆ Designer White/Harvest	LDW1C
◆ Designer White/Kingswood Walnut	LDW1LKI1
◆ Designer White/Loft	LDW1LOFT
◆ Designer White/Mahogany	LDW1N
◆ Designer White/Mocha	LDW1MOCH
◆ Designer White/Natural Maple	LDW1D
◆ Designer White/Pinnacle	LDW1PINC

TWO-TONE LAMINATE TOP / CHASSIS *continued*

L1 LAMINATES	CODES
Two-Tone Top/Chassis	
◆ Designer White/Shaker Cherry	LDW1F
◆ Designer White/Sterling Ash	LDW1LSA1
◆ Harvest/Black	CP
◆ Harvest/Charcoal	CS
◆ Harvest/Designer White	CLDW1
◆ Harvest/Loft	CLOFT
◆ Loft/Black	LOFTP
◆ Loft/Charcoal	LOFTS
◆ Loft/Designer White	LOFTLDW1
◆ Mahogany/Black	NP
◆ Mahogany/Charcoal	NS
◆ Mahogany/Designer White	NLDW1
◆ Mahogany/Loft	NLOFT
◆ Mocha/Black	MOCHP
◆ Mocha/Charcoal	MOCHS
◆ Mocha/Designer White	MOCHLDW1
◆ Mocha/Loft	MOCHLOFT
◆ Natural Maple/Black	DP
◆ Natural Maple/Charcoal	DS
◆ Natural Maple/Designer White	DLDW1
◆ Natural Maple/Loft	DLOFT
◆ Pinnacle/Black	PINCP
◆ Pinnacle/Charcoal	PINCS
◆ Pinnacle/Designer White	PINCLDW1
◆ Pinnacle/Loft	PINCLLOFT
◆ Shaker Cherry/Black	FP
◆ Shaker Cherry/Charcoal	FS
◆ Shaker Cherry/Designer White	FLDW1
◆ Shaker Cherry/Loft	FLOFT

TWO-TONE LAMINATE TOP / CHASSIS *continued*

L2 LAMINATES	CODES
Two-Tone Top/Chassis	
◆ Designer White/Lowell Ash	LDW1LLA1
◆ Designer White/Natural Recon	LDW1LNR1
◆ Designer White/Phantom Ecru	LDW1LPE1
◆ Designer White/Portico Teak	LDW1LPT1
◆ Designer White/Skyline Walnut	LDW1LSW1
◆ Florence Walnut/Black	LFW1P
◆ Florence Walnut/Charcoal	LFW1S
◆ Florence Walnut/Designer White	LFW1LDW1
◆ Florence Walnut/Loft	LFW1LOFT
◆ Kingswood Walnut/Black	LKI1P
◆ Kingswood Walnut/Charcoal	LKI1S
◆ Kingswood Walnut/Designer White	LKI1LDW1
◆ Kingswood Walnut/Loft	LKI1LOFT
◆ Lowell Ash/Black	LLA1P
◆ Lowell Ash/Charcoal	LLA1S
◆ Lowell Ash/Designer White	LLA1LDW1
◆ Lowell Ash/Loft	LLA1LOFT
◆ Natural Recon/Black	LNR1P
◆ Natural Recon/Charcoal	LNR1S
◆ Natural Recon/Designer White	LNR1LDW1
◆ Natural Recon/Loft	LNR1LOFT
◆ Phantom Ecru/Black	LPE1P
◆ Phantom Ecru/Charcoal	LPE1S
◆ Phantom Ecru/Designer White	LPE1LDW1
◆ Phantom Ecru/Loft	LPE1LOFT

TWO-TONE LAMINATE TOP / CHASSIS *continued*

L2 LAMINATES	CODES
Two-Tone Top/Chassis	
◆ Portico Teak/Black	LPT1P
◆ Portico Teak/Charcoal	LPT1S
◆ Portico Teak/Designer White	LPT1LDW1
◆ Portico Teak/Loft	LPT1LOFT
◆ Skyline Walnut/Black	LSW1P
◆ Skyline Walnut/Charcoal	LSW1S
◆ Skyline Walnut/Designer White	LSW1LDW1
◆ Skyline Walnut/Loft	LSW1LOFT
◆ Sterling Ash/Black	LSA1P
◆ Sterling Ash/Charcoal	LSA1S
◆ Sterling Ash/Designer White	LSA1LDW1
◆ Sterling Ash/Loft	LSA1LOFT

HLAM3772RD, HLAM3348RR

EDGEBAND COLORS CODES

Woodgrain	CODES
◆ Bourbon Cherry	H
◆ Cognac	COGN
◆ Florence Walnut	FW
◆ Harvest	C
◆ Kingswood Walnut	KI
◆ Lowell Ash	DL
◆ Mahogany	N
◆ Mocha	MOCH
◆ Natural Maple	D
◆ Natural Recon	NR
◆ Phantom Ecru	PE
◆ Pinnacle	PINC
◆ Portico Teak	DP
◆ Shaker Cherry	F
◆ Skyline Walnut	SW
◆ Sterling Ash	SA
Solid	
◆ Black	P
◆ Charcoal	S
◆ Designer White	DW
◆ Loft	LOFT

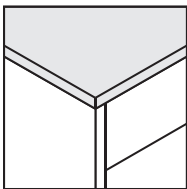

Laminate Chassis

Two-tone laminates: Top and edgebanding are the same, *chassis* is different laminate color.

The following 10500 Series™ products are not available as two-tone. They are one color and require only one color code:

- Modular pedestals — box/file, box/box/file, file/file, lateral file, multi file, and cabinet (also applies to Valido/11500 Series).
- Access strip and end panel kits
- Back enclosures
- Wall mounted open shelf
- Reception stations for return
- T-shaped end panels
- L-shaped end panels

Storage chassis that are specified in L2 laminates and are longer than 60" W will ship with back panels that are horizontal grain.

- Edgebanding on two-tone laminates matches top, *chassis* is a different laminate color.
- A complete selection of Conference Room and Occasional Tables is shown under Tables on pages 714-716, 718-719, 722, and 734-750.

LAMINATE DESKS

SPECIFY: Model Number.

Laminate

EXAMPLE: H10596.HP

- All specifications in this publication are based on the latest product information available at the time of print.

◆◆◆ For lead time information see page 19.

10500 SERIES™

Typicals



Icon Legend on page 19

Components used are listed on pages 244-288. Order components individually. Other configurations are possible, including various sizes of some components.

QTY	DESCRIPTION	MODEL	LIST PRICE	PRICE EXTENSION
1	Rectangle Worksurface 78"W x 30"D	H105R3078	\$429	\$429
1	O-Leg 30"D x 28½"H	HLSL30280	\$346	\$346
1	Low Credenza 72"W x 20"D x 21½"H, Drawers Right, Bookcase Left	H105975R	\$1,324	\$1,324
1	O-Leg Support over Low Credenza 30"D x 7"H	HLSL3070	\$271	\$271
1	Multi-Use Stack-On Storage 36"W x 18"D x 45½"H	H105310	\$1,059	\$1,059
TOTAL:			\$3,429	

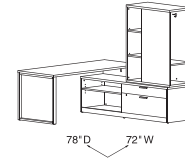

DESK L-WORKSTATION
72\"/>

QTY	DESCRIPTION	MODEL	LIST PRICE	PRICE EXTENSION
1	Rectangle Worksurface 72"W x 30"D	H105R3072	\$402	\$402
1	Modesty/Back Panels - Full Length 72"W x 27⅞"H	HNLMP7228	\$285	\$285
1	Coordinate™ Height Adjustable Base	HHAB2S2L	\$1,006	\$1,006
2	Shroud for Height Adjustable Base	HLAMSHB30	\$848	\$1,696
1	Credenza with Doors 72"W x 24"D x 29½"H	H105909	\$1,827	\$1,827
1	Stack-On Storage 72"W x 14⅝"D x 37⅞"H, 4 Doors	H10534	\$1,011	\$1,011
TOTAL:			\$6,227	

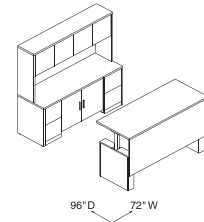

HEIGHT ADJUSTABLE TABLE
WORKSTATION WITH STACK-ON
STORAGE
72\"/>

QTY	DESCRIPTION	MODEL	LIST PRICE	PRICE EXTENSION
1	Single Pedestal Desk, Left - B/F 66"W x 30"D x 29½"H	H10584L	\$1,039	\$1,039
1	Return, Right - B/F 42"W x 24"D x 29½"H	H10511R	\$819	\$819
1	Stack-on Storage 72"W x 14⅝"D x 37⅞"H	H10534	\$1,011	\$1,011
TOTAL:			\$2,869	

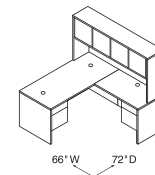

DESK "L" WORKSTATION - RIGHT
66\"/>

QTY	DESCRIPTION	MODEL	LIST PRICE	PRICE EXTENSION
1	Double Full Pedestal Desk - 3/2 72"W x 36"D x 29½"H	H105890	\$1,702	\$1,702
1	Credenza with Kneespace - 2/0/2 72"W x 24"D x 29½"H	H105900	\$1,493	\$1,493
1	Stack-on Storage, Frosted Doors with Silver Frame 72"W x 14⅝"D x 37⅞"H	H10534G	\$1,611	\$1,611
TOTAL:			\$4,806	

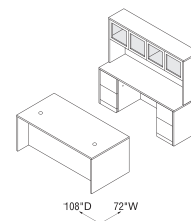

DESK/CREDENZA/STACK-ON STORAGE
WITH FROSTED DOORS
72\"/>



Icon Legend on page 19

10500 SERIES™ Typicals

Components used are listed on pages 244-288. Order components individually. Other configurations are possible, including various sizes of some components.

QTY	DESCRIPTION	MODEL	LIST PRICE	PRICE EXTENSION
1	Storage/File Cabinet 18"W x 24"D x 66 ⁵ / ₈ "H, Hinged Right	H105297R	\$1,692	\$1,692
1	Open Credenza 36"W x 24"D x 21 ¹ / ₂ "H	H105LCHAT3024S	\$220	\$220
1	Open/Lateral Credenza 30"W x 24"D x 21 ¹ / ₂ "H	H105LC3024SF	\$490	\$490
1	Modular Credenza Top 60"W x 24"D	H105CTHAT6024L	\$683	\$683
1	Wall Mounted Open Hutch, Cubby w/Glass Doors 60"W x 14 ⁵ / ₈ "D x 20"H	H105WMH60PCG	\$1,661	\$1,661
1	Height Adjustable Base 24"D	HHAB3S2L	\$1,120	\$1,120
1	Shroud for Height Adjustable Base 5 ¹ / ₈ "W x 26"D x 26 ¹ / ₄ "H	HLAMSHB30	\$848	\$848
1	Rectangle Worksurface 66"W x 30"D	H105R3066	\$374	\$374
1	Mixed Material Floating Modesty Panel 36"W x 14"H	HLSL3614MM	\$726	\$726
TOTAL:			\$7,814	

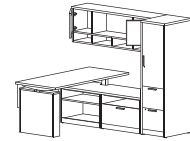

**HEIGHT ADJUSTABLE
"L" WORKSTATION
66"W x 78"D**

QTY	DESCRIPTION	MODEL	LIST PRICE	PRICE EXTENSION
1	H-Leg Support 30"W x 28 ³ / ₈ "H	H105HLEG3028	\$352	\$352
1	Rectangle Worksurface 66"W x 30"D	H105R3066	\$374	\$374
1	External Channel 54"W	HLSLZ5SC66	\$101	\$101
1	Flat Bracket 24"D	HHN831124	\$64	\$64
1	Return Shell w/Full Modesty Panel 72"W x 24"D x 29 ¹ / ₂ "H	H105686	\$696	\$696
1	Multi File Pedestal, Floor-Standing 36"W x 20"D x 28"H	H10505	\$1,249	\$1,249
1	Personal Storage Tower, Hinged Right 24"W x 24"D x 66 ⁵ / ₈ "H	H105301R	\$2,139	\$2,139
1	Wall Mounted Open Hutch 72"W x 14 ⁵ / ₈ "D x 15"H	H105WMH72P	\$1,400	\$1,400
1	Laminate Floating Modesty Panel 54"W x 14"H	HLSL5414L	\$232	\$232
TOTAL:			\$6,607	

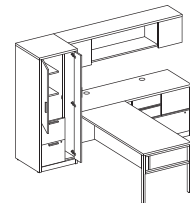

**EXTENDED STORAGE
"L" WORKSTATION
66"W x 96"D**

QTY	DESCRIPTION	MODEL	LIST PRICE	PRICE EXTENSION
1	Single Full Pedestal Desk, Right - B/B/F 72"W x 36"D x 29 ¹ / ₂ "H	H105895R	\$1,361	\$1,361
1	Bridge 47"W x 24"D x 29 ¹ / ₂ "H	H10570	\$364	\$364
1	Single Full Pedestal Credenza, Left - F/F 72"W x 24"D x 29 ¹ / ₂ "H	H105904L	\$1,210	\$1,210
1	Stack-on Storage 72"W x 14 ⁵ / ₈ "D x 37 ¹ / ₈ "H	H10534	\$1,011	\$1,011
TOTAL:			\$3,946	

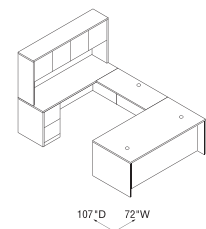

**"U" WORKSTATION
WITH FULL PEDESTALS
72"W x 107"D**

10500 SERIES™

Typicals



Icon Legend on page 19

Components used are listed on pages 244-288. Order components individually. Other configurations are possible, including various sizes of some components.

QTY	DESCRIPTION	MODEL	LIST PRICE	PRICE EXTENSION
1	Rudder Peninsula with End Panel, Right 72"W x 30/38"D x 29½"H	H105205R	\$1,113	\$1,113
1	Return, Left - F/F 42"W x 24"D x 29½"H	H105908L	\$941	\$941
1	Stack-on Storage 72"W x 14⅝"D x 37⅞"H	H10534	\$1,011	\$1,011
TOTAL:			\$3,065	

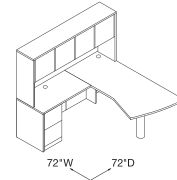

PENINSULA "L" WORKSTATION

72" W x 72" D

QTY	DESCRIPTION	MODEL	LIST PRICE	PRICE EXTENSION
1	Peninsula with End Panel 72"W x 36"D x 29½"H	H10521	\$877	\$877
1	Bridge 42"W x 24"D x 29½"H	H10560	\$350	\$350
1	Extended Corner Unit, Left 72"W x 24"-36"D x 29½"H	H105816L	\$1,074	\$1,074
1	Mobile Pedestal - B/B/F 15¾"W x 22¾"D x 28"H	H105102	\$854	\$854
1	Stack-on Storage 72"W x 14⅝"D x 37⅞"H	H10534	\$1,011	\$1,011
1	Storage Cabinet/Lateral File 36"W x 24"D x 66⅝"H	H105293	\$2,278	\$2,278
TOTAL:			\$6,444	

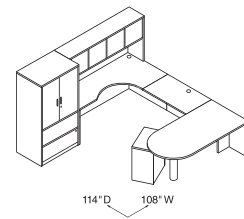

PENINSULA "U" WORKSTATION - LEFT

108" W x 114" D

QTY	DESCRIPTION	MODEL	LIST PRICE	PRICE EXTENSION
1	Slide Out Tower, Left Hinged 12"W x 24"D x 50"H	H105ST122450L	\$2,705	\$2,705
1	Open Credenza 30"W x 24"D x 21½"H	H105LCHAT3024S	\$220	\$220
1	Open/Lateral Credenza 30"W x 24"D x 21½"H	H105LC3024SF	\$490	\$490
1	Modular Credenza Top 60"W x 24"D	H105CTHAT6024R	\$683	\$683
1	Height Adjustable Base 24"D	HHAB3S2L	\$1,120	\$1,120
1	Shroud for Height Adjustable Base 5⅞"W x 26"D x 26¼"H	HLAMSHB30	\$848	\$848
1	Rectangle Worksurface 66"W x 30"D	H105R3066	\$374	\$374
1	Laminate Floating Modesty Panel 30"W x 14"H	HLSL3014L	\$169	\$169
1	2-Drawer Credenza 30"W x 24"D x 21½"H	H105LC3024BF	\$556	\$556
1	Modular Credenza Top 30"W x 24"D	H105CT3024	\$395	\$395
1	Fabric Credenza Top 30"W x 24"D	HLAMSEAT3024	\$405	\$405
TOTAL:			\$7,965	

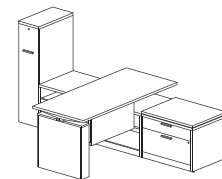

**HEIGHT ADJUSTABLE "L" WORKSTATION
WITH SLIDE OUT STORAGE**

66" W x 102" D



Icon Legend on page 19

10500 SERIES™ Bundles Typicals

Mahogany
H105LL7284N

Harvest
H105LL7284C

QTY	DESCRIPTION	MODEL	LIST PRICE	PRICE EXTENSION
1	Left Pedestal Desk	H10586L	\$1,182	\$1,182
1	Right Return	H10515R	\$837	\$837
TOTAL:			\$2,019	

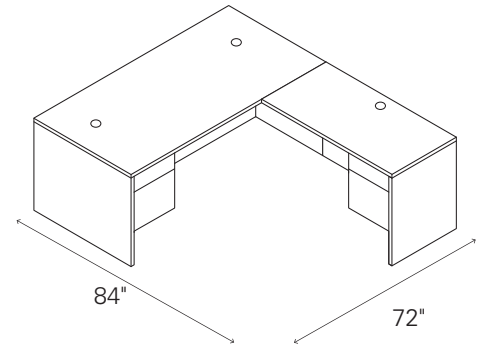

L-STATION (LEFT DESK/RIGHT RETURN)

Mahogany
H105LR7284N

Harvest
H105LR7284C

QTY	DESCRIPTION	MODEL	LIST PRICE	PRICE EXTENSION
1	Right Pedestal Desk	H10585R	\$1,182	\$1,182
1	Left Return	H10516L	\$837	\$837
TOTAL:			\$2,019	

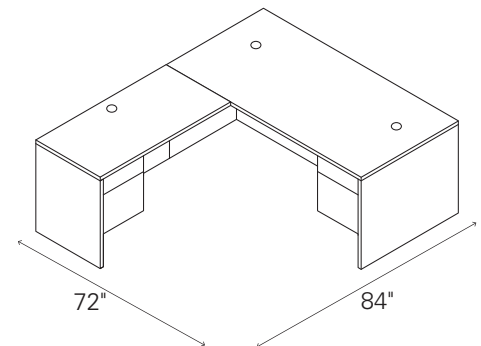

L-STATION (RIGHT DESK/LEFT RETURN)

Mahogany
H105LLH7284N

Harvest
H105LLH7284C

QTY	DESCRIPTION	MODEL	LIST PRICE	PRICE EXTENSION
1	Left Pedestal Desk	H10586L	\$1,182	\$1,182
1	Right Return	H10515R	\$837	\$837
1	Stack-on Storage	H105323	\$850	\$850
TOTAL:			\$2,869	

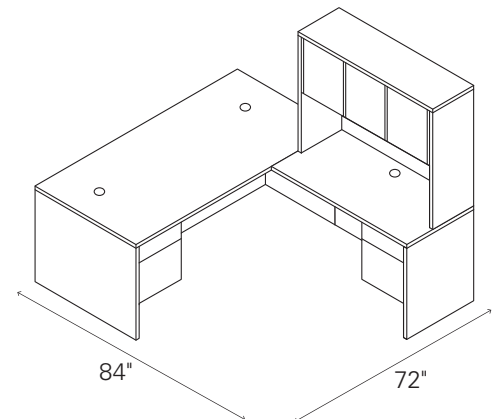

**L-STATION WITH STACK-ON STORAGE
(LEFT DESK/RIGHT RETURN)**

10500 SERIES™ Bundles Typicals



Icon Legend on page 19

Mahogany
H105LRH7284N

Harvest
H105LRH7284C

QTY	DESCRIPTION	MODEL	LIST PRICE	PRICE EXTENSION
1	Right Pedestal Desk	H10585R	\$1,182	\$1,182
1	Left Return	H10516L	\$837	\$837
1	Stack-on Storage	H105323	\$850	\$850
TOTAL:			\$2,869	

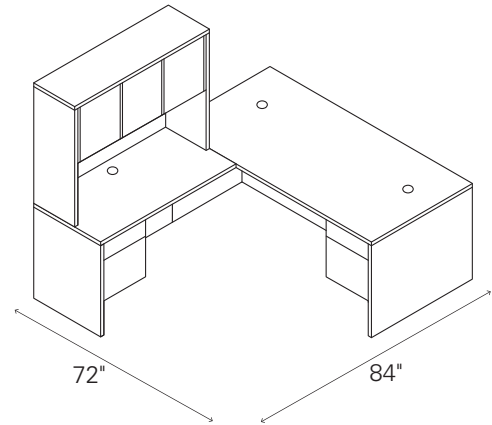

**L-STATION WITH STACK-ON STORAGE
(RIGHT DESK/LEFT RETURN)**

Mahogany
H105ULH72108N

Harvest
H105ULH72108C

QTY	DESCRIPTION	MODEL	LIST PRICE	PRICE EXTENSION
1	Left Pedestal Desk	H10586L	\$1,182	\$1,182
1	Right Pedestal Credenza	H10545R	\$1,023	\$1,023
1	Bridge	H10570	\$364	\$364
1	Stack-on Storage	H10534	\$1,011	\$1,011
TOTAL:			\$3,580	

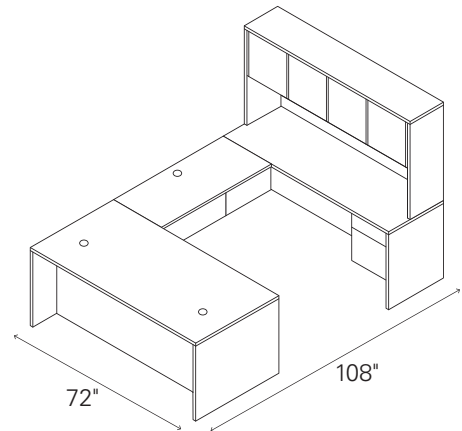

**U-STATION WITH STACK-ON STORAGE
(LEFT DESK/RIGHT CREDENZA)**

Mahogany
H105URH72108N

Harvest
H105URH72108C

QTY	DESCRIPTION	MODEL	LIST PRICE	PRICE EXTENSION
1	Right Pedestal Desk	H10585R	\$1,182	\$1,182
1	Left Pedestal Credenza	H10546L	\$1,023	\$1,023
1	Bridge	H10570	\$364	\$364
1	Stack-on Storage	H10534	\$1,011	\$1,011
TOTAL:			\$3,580	

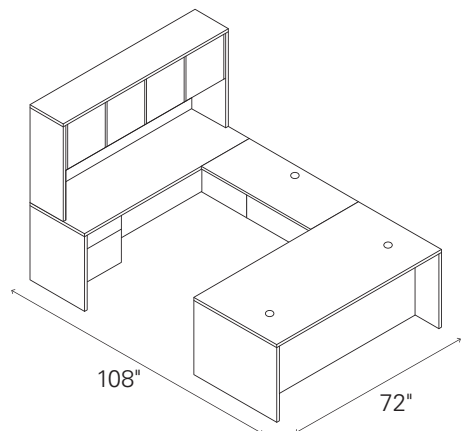

**U-STATION WITH STACK-ON STORAGE
(RIGHT DESK/LEFT CREDENZA)**



Icon Legend on page 19

10500 SERIES™ Bundles Typicals

Mahogany
H105DLH7298N

Harvest
H105DLH7298C

QTY	DESCRIPTION	MODEL	LIST PRICE	PRICE EXTENSION
1	Double Pedestal Desk	H10593	\$1,391	\$1,391
2	Bookcase Hutch	H105292	\$570	\$1,140
1	2-Drawer Lateral File	H10563	\$973	\$973
1	Storage Cabinet with Doors	H105291	\$781	\$781
TOTAL:			\$4,285	

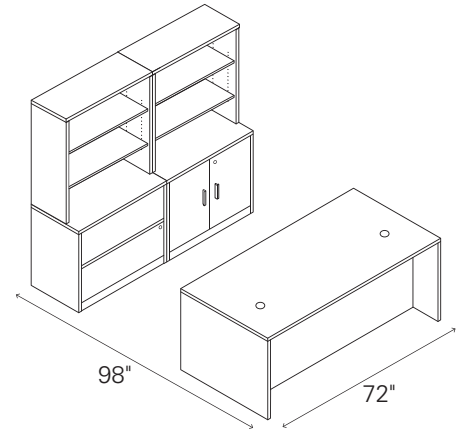

STORAGE WORKSTATION

Mahogany
H105DCH6098N

Harvest
H105DCH6098C

QTY	DESCRIPTION	MODEL	LIST PRICE	PRICE EXTENSION
1	Double Pedestal Desk	H10573	\$1,172	\$1,172
1	Double Pedestal Credenza	H10565	\$1,172	\$1,172
1	Stack-on Storage	H105324	\$943	\$943
TOTAL:			\$3,287	

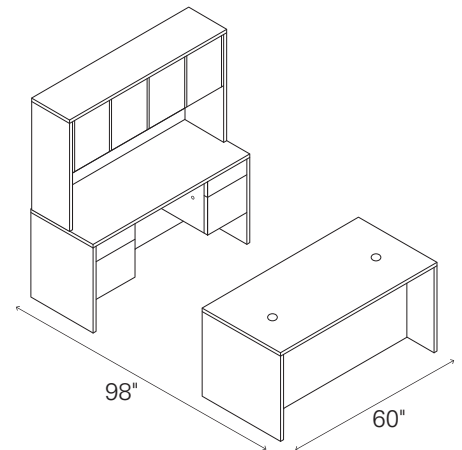

DESK CREDENZA STACK-ON #1

Mahogany
H105DCH7298N

Harvest
H105DCH7298C

QTY	DESCRIPTION	MODEL	LIST PRICE	PRICE EXTENSION
1	Double Pedestal Desk	H10593	\$1,391	\$1,391
1	Double Pedestal Credenza	H10543	\$1,240	\$1,240
1	Stack-on Storage	H10534	\$1,011	\$1,011
TOTAL:			\$3,642	

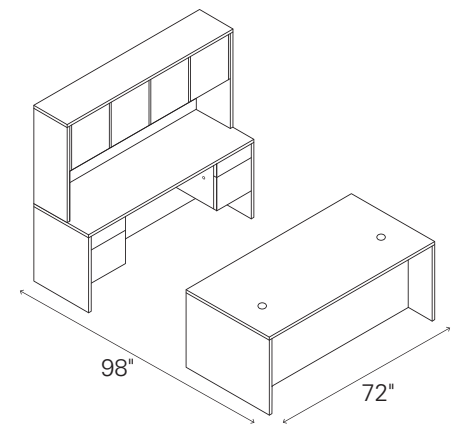

DESK CREDENZA STACK-ON #2

10500 SERIES™

Laminate Modular Components

GSA SIN 33721



Icon Legend on page 19

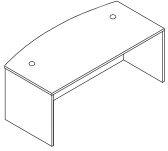

Model H10596 shown

DESCRIPTION	INSIDE DIMENSIONS	FULL WIDTH OVERHANG	MODEL	SHIP WEIGHT	CUBE	LIST PRICE BY LAMINATE GRADE	
						L1	L2
Desk Shell (with full modesty panel and 2 grommets)							
72"W x 36"D x 29½"H, Bow Top (end panels 30"D)	69½"W x 24⅝"D	10½"	H10596	192	6.9	\$894	\$944
72"W x 36"D x 29½"H, Rectangle Top	69½"W x 24⅝"D	10½"	H10594	209	6.9	\$807	\$857
72"W x 30"D x 29½"H, Rectangle Top	69½"W x 24⅝"D	4½"	H10592	182	5.8	\$765	\$805
66"W x 30"D x 29½"H, Rectangle Top	63½"W x 24⅝"D	4½"	H10579	172	5.4	\$725	\$765
60"W x 30"D x 29½"H, Rectangle Top	57½"W x 24⅝"D	4½"	H10578	161	5.0	\$674	\$714
48"W x 30"D x 29½"H, Rectangle Top (1 grommet)	45½"W x 24⅝"D	4½"	H10598	141	5.0	\$626	\$656
NOTES: See page 288 for optional center drawers.							
Desk Shell (with 10"H modesty panel and 2 grommets)							
72"W x 36"D x 29½"H, Bow Top (end panels 30"D)	69½"W x 24⅝"D	10½"	H10596X	155	6.1	\$894	\$944
72"W x 36"D x 29½"H, Rectangle Top	69½"W x 24⅝"D	10½"	H10594X	153	6.1	\$807	\$857
72"W x 30"D x 29½"H, Rectangle Top	69½"W x 24⅝"D	4½"	H10592X	143	5.1	\$765	\$805
66"W x 30"D x 29½"H, Rectangle Top	63½"W x 24⅝"D	4½"	H10579X	134	4.7	\$725	\$765
60"W x 30"D x 29½"H, Rectangle Top	57½"W x 24⅝"D	4½"	H10578X	125	4.4	\$674	\$714
48"W x 30"D x 29½"H, Rectangle Top (1 grommet)	45½"W x 24⅝"D	4½"	H10598X	115	4.4	\$626	\$656
NOTES: Makes reaching wall electrical outlets quick and easy. Provides more than 18" of clearance. See pages 269-270 for optional stack-on storage and page 288 for optional center drawers.							

NOTES:

- Non-handed desk, credenza, and return shells, combined with a variety of under-the-worksurface storage solutions, maximize office layout flexibility. Products can be reconfigured quickly and easily when user preferences or space needs change.
- For under-surface storage options, see pages 258-260.
- For additional components see pages 265-288.
- Tops and end panels are abrasion- and stain-resistant laminate over durable 1⅝" solid core high-performance particleboard; resists warping.
- Cord management grommets, for routing and hiding wires and cables, are located in the tops of desks and return shells.
- 3" round worksurface grommet can be replaced with optional Power Hub (model HGRMTAC) or Power/USB Hub (model HGRMTUSB2) to bring the ease of plug-and-play to the desktop. See page 287.
- Adjustable hex leveling glides allow floor-standing furniture to be easily leveled without lifting the unit; glides have ¾" adjustable range.
- For standing, 42"H shells, see page 247.

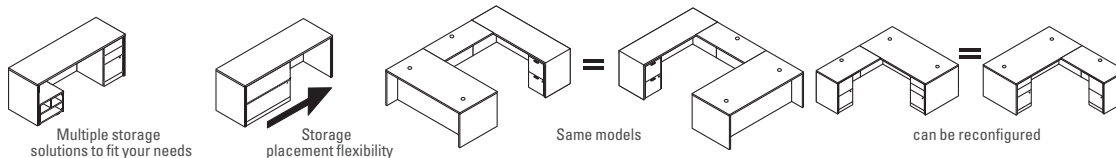
**HOW TO SPECIFY**

Select
Model Number

H 1 0 5 9 6 .

Select
Laminate Top and Chassis Color

See pages 236-237

N N



Icon Legend on page 19

10500 SERIES™

Laminate Modular Components

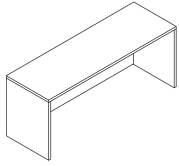

DESCRIPTION	INSIDE DIMENSIONS	MODEL	SHIP WEIGHT	CUBE	LIST PRICE BY LAMINATE GRADE	
					L1	L2
Credenza Shell (with full modesty panel)						
72"W x 24"D x 29½"H	69½"W x 22¾"D	H10541	153	5.6	\$696	\$736
66"W x 24"D x 29½"H	63½"W x 22¾"D	H10542	144	5.1	\$681	\$721
60"W x 24"D x 29½"H	57½"W x 22¾"D	H10564	135	4.7	\$637	\$672
48"W x 24"D x 29½"H	45½"W x 22¾"D	H105692	124	3.9	\$610	\$640
42¼"W x 24"D x 29½"H	39¾"W x 22¾"D	H105691	110	3.8	\$590	\$620
72"W x 20"D x 29½"H	69½"W x 18¾"D	H105581	138	5.6	\$657	\$692
66"W x 20"D x 29½"H	63½"W x 18¾"D	H105582	130	5.1	\$641	\$676
60"W x 20"D x 29½"H	57½"W x 18¾"D	H105583	122	4.7	\$608	\$638

NOTES: Cord pass-through in top center of modesty panel. See pages 269-270 for optional stack-on storage.

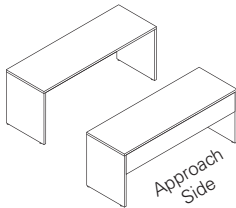

DESCRIPTION	INSIDE DIMENSIONS	MODEL	SHIP WEIGHT	CUBE	LIST PRICE BY LAMINATE GRADE	
					L1	L2
Credenza Shell (with 10" H modesty panel)						
72"W x 24"D x 29½"H	69½"W x 22¾"D	H10541X	114	4.8	\$696	\$736
66"W x 24"D x 29½"H	63½"W x 22¾"D	H10542X	107	4.4	\$681	\$721
60"W x 24"D x 29½"H	57½"W x 22¾"D	H10564X	105	4.0	\$637	\$672
48"W x 24"D x 29½"H	45½"W x 22¾"D	H105692X	95	3.8	\$610	\$640
42¼"W x 24"D x 29½"H	39¾"W x 22¾"D	H105691X	87	3.8	\$590	\$620
72"W x 20"D x 29½"H	69½"W x 18¾"D	H105581X	107	4.8	\$657	\$692
66"W x 20"D x 29½"H	63½"W x 18¾"D	H105582X	101	4.4	\$641	\$676
60"W x 20"D x 29½"H	57½"W x 18¾"D	H105583X	96	4.0	\$608	\$638

NOTES: Makes reaching wall electrical outlets quick and easy. Provides more than 18" of clearance. See pages 269-270 for optional stack-on storage.



Not available in two-tone laminate

DESCRIPTION	MODEL	SHIP WEIGHT	CUBE	L1	L2
				LIST PRICE	LIST PRICE
Kneespace Clearance End Panel Kits (field installable)					
1½"W x 11¼"D x 28½"H	H105098	13	0.9	\$210	\$220
For use at either end of 10500, 10700 or Valido Series® 24"D Credenza Shells (with full or 10" modesty panel) or non-pedestal end of single pedestal credenzas or credenzas with lateral files.					
1½"W x 17¼"D x 28½"H	H105099	11	0.8	\$220	\$230
For use at either end of 10500, 10700 or Valido Series® 30"D Desk Shells or non-pedestal end of 30"D single pedestal desks.					
Kits include: (1) support panel; European fastening hardware; flat connector bracket; joint connector bolts with sleeve nuts (for ganging credenza to adjacent worksurface); and adjustable leveling glides. Allows conversion of units currently in the field.					
NOTES: Can be used to connect up to three 24"D credenzas or 30"D desks in line (requires 4 kits).					
⚠ Not designed to be used freestanding. Not designed to be used with returns, 36"D desks or desk shells.					
SPECIFYING EXAMPLE: H105098.N					

NOTES:

- Non-handed desk, credenza, and return shells, combined with a variety of under-the-worksurface storage solutions, maximize office layout flexibility. Products can be reconfigured quickly and easily when user preferences or space needs change.
- For 78", 84", 90", and 96"W credenza shells, see page 246.
- For under-surface storage options, see pages 258-260.
- Tops and end panels are abrasion- and stain-resistant laminate over durable 1/8" solid core high-performance particleboard; resists warping.
- For additional components see pages 265-288.
- For work-in-process paper management tools, see pages 282-283.
- Cord management grommets, for routing and hiding wires and cables, are located in the tops of desks and return shells.
- Credenza shells have a cord pass-through grommet in the top center of the modesty panel.
- Kneespace Clearance End Panel Kit model H105098, can be used to create "L" configurations with leg clearance, by connecting credenzas to single pedestal desks or credenzas, desk or credenza shells, corners, extended corners or peninsulas.
- Adjustable hex leveling glides allow floor-standing furniture to be easily leveled without lifting the unit; glides have 3/4" adjustable range.

HOW TO SPECIFY

Select Model Number

H 1 0 5 4 1 .

Select Laminate Top and Chassis Color

See pages 236-237

N N

10500 SERIES™

Laminate Modular Components

GSA SIN 33721



Icon Legend on page 19

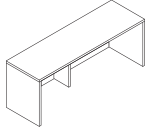

DESCRIPTION	INSIDE DIMENSIONS	MODEL	SHIP WEIGHT	CUBE	LIST PRICE BY LAMINATE GRADE	
					L1	L2
Credenza Shell (with full modesty panel)						
96"W x 24"D x 29½"H	93½"W x 22¾"D	H105413	215	7.0	\$991	\$1046
90"W x 24"D x 29½"H	87½"W x 22¾"D	H105412	202	6.6	\$964	\$1014
84"W x 24"D x 29½"H	81½"W x 22¾"D	H105411	189	6.2	\$855	\$905
78"W x 24"D x 29½"H	75½"W x 22¾"D	H105410	176	5.8	\$832	\$877

NOTES: Larger sizes can be used in conjunction with a 10500 Series rectangle- or bullet-shaped worksurface, supported by an end panel, column or leg, to achieve a space efficient work wall configuration. Shells wider than 72" include an internal, 10½"D vertical support leg. The internal leg can be removed if it is replaced with a 10500 Series 28"H modular pedestal that is adjusted to support the credenza shell top. Cord pass-through in top center of modesty panel. See pages 269-270 for optional stack-on storage and the stack-on storage end panel kit (model H105349).

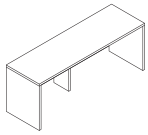

Credenza Shell (with 10"H modesty panel)						
96"W x 24"D x 29½"H	93½"W x 22¾"D	H105413X	163	6.1	\$991	\$1046
90"W x 24"D x 29½"H	87½"W x 22¾"D	H105412X	152	5.7	\$964	\$1014
84"W x 24"D x 29½"H	81½"W x 22¾"D	H105411X	141	5.4	\$855	\$905
78"W x 24"D x 29½"H	75½"W x 22¾"D	H105410X	130	5.0	\$832	\$877

NOTES: Makes reaching wall electrical outlets quick and easy. Provides more than 18" of clearance. Larger sizes can be used in conjunction with a 10500 Series rectangle- or bullet-shaped worksurface, supported by an end panel, column or leg, to achieve a space efficient work wall configuration. Shells wider than 72" include an internal, 10½"D vertical support leg. The internal leg can be removed if it is replaced with a 10500 Series 28"H modular pedestal that is adjusted to support the credenza shell top. See pages 269-270 for optional stack-on storage and the stack-on storage end panel kit (model H105349).

NOTES:

- Non-handed desk, credenza, and return shells, combined with a variety of under-the-worksurface storage solutions, maximize office layout flexibility. Products can be reconfigured quickly and easily when user preferences or space needs change.
- For under-surface storage options, see pages 258-260.
- For additional components see pages 265-288.
- Tops and end panels are abrasion- and stain-resistant laminate over durable 1½" solid core high-performance particleboard; resists warping.
- Credenza shells have a cord pass-through grommet in the top center of the modesty panel.
- Kneespace Clearance End Panel Kit model H105098, can be used to create "L" configurations with leg clearance, by connecting credenzas to single pedestal desks or credenzas, desk or credenza shells, corners, extended corners or peninsulas.
- Adjustable hex leveling glides allow floor-standing furniture to be easily leveled without lifting the unit; glides have ¾" adjustable range.

HOW TO SPECIFY

Select
Model Number

H 1 0 5 4 1 3 .

Select
Laminate Top and Chassis Color

See pages 236-237

N N

10500 SERIES™

Laminate Modular Components

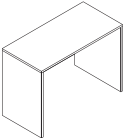
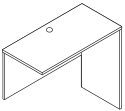
	DESCRIPTION	INSIDE DIMENSIONS	MODEL	SHIP WEIGHT	CUBE	LIST PRICE BY LAMINATE GRADE	
						L1	L2
	Standing-Height Desk Shell						
	60"W x 30"D x 42"H	57½"W x 24½"D x 41⅝"H	H105397	185	6.2	\$837	\$877
	60"W x 24"D x 42"H	57½"W x 22¾"D x 41⅝"H	H105393	154	5.1	\$772	\$812
	48"W x 24"D x 42"H	45⅞"W x 22¾"D x 41⅝"H	H105392	143	4.2	\$722	\$757
	NOTES: Fixed height surface is 42"H. When combined with a stool-height task chair, provides users the benefit of alternating their work between a seated or standing position without the additional cost of an adjustable-height mechanism. Short, 22⅝" modesty panel provides over 18" of wall access; makes reaching wall electrical outlets quick and easy. Box/File Pedestal (H10501) attaches to the underside of the worksurface top to position supplies and files within easy reach.						
	Standing-Height Return Shell						
	48"W x 24"D x 42"H	47"W x 22¾"D x 41⅝"H	H105663	96	3.1	\$606	\$641
	NOTES: Non-handed design. Attaches to sit/stand desk shells to form an L-shaped workstation. Short, 22⅝" modesty panel makes reaching wall electrical outlets quick and easy. One cord management grommet in top for routing and hiding wires and cables. Grommet can be replaced with optional Power Hub (model HGRMTAC). Box/File Pedestal (H10501) attaches to the underside of the worksurface top to position supplies and files within easy reach.						

NOTES:

- 42"H shells help support a healthy work style by allowing users to switch between sitting and standing.
- Non-handed desk and return shells maximize office layout flexibility. Products can be reconfigured quickly and easily when user preferences or space needs change.
- Tops and end panels are abrasion- and stain-resistant laminate over durable 1⅝" solid core high-performance particleboard; resists warping.
- For additional components see pages 265-288.
- Mobile pedestals, shown on page 276, work well in a variety of applications and configurations.
- Adjustable hex leveling glides allow floor-standing furniture to be easily leveled without lifting the unit; glides have ¾" adjustable range.

HOW TO SPECIFY

Select Model Number H 1 0 5 3 9 7	Select Laminate Top and Chassis Color See pages 236-237 N N
---	--

10500 SERIES™

Laminate Modular Components

GSA SIN 33721



Icon Legend on page 19

Model H105686
shown

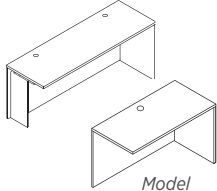

Model
H105686
shown

DESCRIPTION	INSIDE DIMENSIONS	MODEL	SHIP WEIGHT	CUBE	LIST PRICE BY LAMINATE GRADE	
					L1	L2
Return Shell (with full modesty panel)						
72"W x 24"D x 29½"H, (w/support; 2 grommets)	67"W x 22¾"D	H105686	145	5.4	\$696	\$736
60"W x 24"D x 29½"H, (w/support; 2 grommets)	55"W x 22¾"D	H105684	129	4.4	\$637	\$672
48"W x 24"D x 29½"H, (1 grommet)	47"W x 22¾"D	H10561	86	3.7	\$524	\$554
42"W x 24"D x 29½"H, (1 grommet)	41"W x 22¾"D	H105681	89	2.5	\$492	\$522
36"W x 24"D x 29½"H, (1 grommet)	34⅞"W x 22¾"D	H105680	83	3.2	\$492	\$517
30"W x 24"D x 29½"H, (1 grommet)	28⅞"W x 22¾"D	H10568	69	2.6	\$470	\$495

NOTES: Shells are non-handed. No pre-drilled grommet in modesty panel (field installable grommet included). Woodgrain direction on modesty/back panel runs vertical on 30"W-60"W sizes and horizontal on 72"W unit. 36"W return shell can be used to achieve a 6' x 6' L-shaped footprint when connected to either a 72"W x 36"D single pedestal desk, desk shell, or peninsula, or when two are connected to 36"W corner unit model H105811. 30"W return shell can be used to accomplish a 5' x 5' L-shaped footprint when connected to a 60"W x 30"D desk shell or peninsula. See pages 269-270 for optional stack-on storage.

ⓘ Not designed to attach to corner units manufactured prior to 5/24/99.

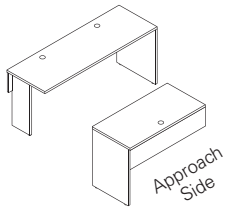

Return Shell (with 10"H modesty panel)						
72"W x 24"D x 29½"H, (w/support; 2 grommets)	67"W x 22¾"D	H105686X	106	4.6	\$696	\$736
60"W x 24"D x 29½"H, (w/support; 2 grommets)	55"W x 22¾"D	H105684X	93	3.9	\$637	\$672
48"W x 24"D x 29½"H, (1 grommet)	47"W x 22¾"D	H10561X	78	3.1	\$524	\$554
42"W x 24"D x 29½"H, (1 grommet)	41"W x 22¾"D	H105681X	69	3.8	\$492	\$522
36"W x 24"D x 29½"H, (1 grommet)	34⅞"W x 22¾"D	H105680X	67	3.8	\$492	\$517
30"W x 24"D x 29½"H, (1 grommet)	28⅞"W x 22¾"D	H10568X	56	2.6	\$470	\$495

NOTES: Makes reaching wall electrical outlets quick and easy. Provides more than 18" of clearance. See pages 269-270 for optional stack-on storage.

NOTES:

- Non-handed desk, credenza, and return shells, combined with a variety of under-the-worksurface storage solutions, maximize office layout flexibility. Products can be reconfigured quickly and easily when user preferences or space needs change.
- For additional components see pages 265-288.
- Tops and end panels are abrasion- and stain-resistant laminate over durable 1½" solid core high-performance particleboard; resists warping.
- Cord management grommets, for routing and hiding wires and cables, are located in the tops of desks and return shells.
- Adjustable hex leveling glides allow floor-standing furniture to be easily leveled without lifting the unit; glides have ¾" adjustable range.
- 36"W and 30"W return shells enable L-shaped layouts for smaller spaces.
- One cord management grommet in tops of Return Shell models, H10568 and H10568X, is used for routing and hiding wires and cables. The 3" round grommet can be replaced with optional Power Hub or Power/USB Hub — see page 287.

HOW TO SPECIFY

Select
Model Number

H 1 0 5 6 8 6 .

Select
Laminate Top and Chassis Color

See pages 236-237

N N



Icon Legend on page 19

10500 SERIES™ Worksurfaces

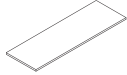
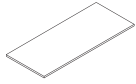

DESCRIPTION

Rectangle Worksurface

84"W x 30"D
78"W x 30"D
72"W x 30"D
66"W x 30"D
60"W x 30"D
48"W x 30"D

84"W x 24"D
78"W x 24"D
72"W x 24"D
66"W x 24"D
60"W x 24"D
48"W x 24"D
42"W x 24"D
36"W x 24"D
30"W x 24"D

MODEL	SHIP WEIGHT	CUBE	LIST PRICE BY LAMINATE GRADE	
			L1	L2
H105R3084	88	6.5	\$475	\$500
H105R3078	81	6.1	\$429	\$454
H105R3072	83	6.1	\$402	\$422
H105R3066	76	6.1	\$374	\$394
H105R3060	69	5.2	\$349	\$369
H105R3048	55	4.1	\$286	\$301
H105R2484	70	5.3	\$437	\$462
H105R2478	65	4.9	\$389	\$409
H105R2472	66	4.9	\$342	\$362
H105R2466	61	4.9	\$331	\$351
H105R2460	55	4.2	\$311	\$331
H105R2448	44	3.4	\$264	\$279
H105R2442	39	3.0	\$239	\$254
H105R2436	30	2.4	\$207	\$222
H105R2430	25	2.0	\$207	\$222

NOTES: Underside of rectangle worksurfaces includes pilot mounting holes for end panels, support columns, post legs, H-legs, and O-legs, and height adjustable base. Applications for 24"D worksurfaces include desks, credenzas, returns, and bridges. For Above Privacy Screen sizes, see page 201.



Bullet Worksurface

72"W x 30"D
66"W x 30"D
60"W x 30"D

60"W x 24"D

H105B3072	79	6.1	\$417	\$437
H105B3066	73	6.1	\$394	\$414
H105B3060	66	5.2	\$376	\$396
H105B2460	45	4.2	\$322	\$337

NOTES: Applications include use as a peninsula in a U- or L-shaped workstation or as an island extension. One flat bracket (mounting plate) ships with each worksurface for applications requiring connection to an adjoining worksurface. Underside includes pilot mounting holes for T- and L-shaped end panels, H-leg, O-leg, support column, post leg, or flat bracket. Grain direction runs horizontal.

ⓘ When specifying 60"W Floating Modesty Panel, it is not necessary to specify an external channel.

DESCRIPTION

External Support Channel

42"W for a 54" Worksurface
48"W for a 60" Worksurface
54"W for a 66" Worksurface
60"W for a 72" Worksurface
72"W for an 84" Worksurface

MODEL	SHIP WEIGHT	CUBE	LIST PRICE
HLSLZ5SC54	5	0.5	\$93
HLSLZ5SC60	6	0.5	\$98
HLSLZ5SC66	7	0.5	\$101
HLSLZ5SC72	7	0.5	\$110
HLSLZ5SC84	12	0.7	\$110

ⓘ Available in Graphite paint only.

ⓘ When specifying panel-hung worksurfaces, specify external channel as if supported by two H-legs or O-legs via selection chart.

ⓘ When specifying a 54"W or 60"W Floating Modesty Panel, it is not necessary to specify an external channel.

NOTES:

- Easy-care, scratch-, spill- and stain-resistant laminate over 1/8" solid core high-performance particleboard.
- Grain direction on all worksurfaces runs horizontal.
- One flat bracket (mounting plate) ships with each worksurface for applications requiring connection to an adjoining worksurface.
- For standing-height requirements, use worksurface with 41"H laminate L-shaped end panel or metal O-leg.
- For 30", 36", 42" and 48"W x 24"D mobile desks and tables, use post leg with casters model HMBPOST.C.
- For end panels, legs, columns and bases, see the Worksurface Supports listing on pages 250-251.
- When using a floating modesty panel or an external channel under the worksurface, the depth clearance for keyboard trays and center drawers decreases by 8". See accessory matrix in accessory section of the pricer.

- ⓘ 84"W worksurfaces are for 29 1/2"H applications only (not 42"H) and require a T-support brace or other weight-bearing floor support to be positioned between the O-legs or L-shaped end panels.
- ⓘ Worksurfaces are subject to slight bowing. The magnitude of the deflection is dependent upon the weight, placement, and duration of the load.
- ⓘ When using a worksurface as a bridge, no additional supports are needed. One support is required for returns, two supports are required for desks and credenzas.
- ⓘ External channel support is recommended for extended unsupported spans or heavily loaded worksurfaces. See above for details.

EXTERNAL SUPPORT CHANNEL (Model HLSLZ5SCxx) — RECOMMENDED USE							
	Support Combination		Rectangle Worksurface Width				
	Support 1	Support 2	60"	66"	72"	78"	84"
O-Leg	O-Leg	O-Leg	66	72	78	84	NA
	O-Leg	4 1/2" Dia. Support Column	NR	60	66	72	78
	O-Leg	2" Square Post Leg	NR	60	66	72	78
L-Shaped End Panel	L End Panel	L End Panel	NR	60	66	72	78
	L End Panel	O-Leg	60	66	72	78	84
	L End Panel	4 1/2" Dia. Support Column	NR	60	66	72	78
	L End Panel	2" Square Post Leg	NR	60	66	72	78
T-Shaped End Panel	T End Panel	O-Leg	60	66	72	78	84
	T End Panel	4 1/2" Dia. Support Column	NR	60	66	72	78
	T End Panel	2" Square Post Leg	NR	60	66	72	78
Return Config End Panel	None	O-Leg	66	72	78	84	NA
	None	L End Panel	60	66	72	78	84

HOW TO SPECIFY

<p>Select Model Number</p> <p>H 1 0 5 R 3 0 7 2</p>	<p>Select Worksurface Laminate and Edge Color</p> <p>See pages 236-237</p> <p>N N</p>
--	--

10500 SERIES™ Worksurface Supports

GSA SIN 33721



Icon Legend on page 19

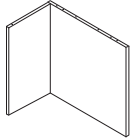

Not available in
two-tone laminate

DESCRIPTION	MODEL	SHIP WEIGHT	CUBE	LIST PRICE BY LAMINATE GRADE	
				L1	L2
L-shaped End Panel					
15 $\frac{3}{4}$ "W x 29 $\frac{7}{8}$ "D x 28 $\frac{1}{2}$ "H	H10530LEP	49	4.1	\$288	\$300
15 $\frac{3}{4}$ "W x 23 $\frac{7}{8}$ "D x 28 $\frac{1}{2}$ "H	H10524LEP	43	3.7	\$270	\$282
15 $\frac{3}{4}$ "W x 29 $\frac{7}{8}$ "D x 41"H	H1053041LEP	68	4.2	\$364	\$384
15 $\frac{3}{4}$ "W x 23 $\frac{7}{8}$ "D x 41"H	H1052441LEP	60	3.4	\$329	\$349

NOTES: Non-handed. 29 $\frac{7}{8}$ "D for use with 48"-78"W x 30"D worksurfaces; 23 $\frac{7}{8}$ "D for use with 30"-78"W x 24"D worksurfaces. Not for use with 84"W unless additional floor supports are placed between the end panels. Design facilitates easy, open access to wall electrical outlets. Adjustable hex glides allow floor-standing units to be easily leveled without lifting to compensate for uneven floors. Glides have $\frac{3}{4}$ " adjustable range. Two pieces; 1 $\frac{1}{8}$ " end panel and $\frac{3}{4}$ " back panel. 10500 Series™ modular and mobile pedestals fit flush to the end panel. Simple assembly.

⚠ Not designed to be used freestanding.

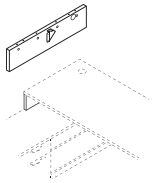

HNLEP307L shown

Laminate End Panel — 7"H Support for Worksurfaces

1 $\frac{1}{8}$ "W x 30"D x 7"H, Right	HNLEP307R	7	0.7	\$133	\$10
1 $\frac{1}{8}$ "W x 30"D x 7"H, Left	HNLEP307L	7	0.7	\$133	\$10
1 $\frac{1}{8}$ "W x 24"D x 7"H, Right	HNLEP247R	6	0.7	\$133	\$10
1 $\frac{1}{8}$ "W x 24"D x 7"H, Left	HNLEP247L	6	0.7	\$133	\$10

NOTES: Specifically for layered surface applications; used to support a 29 $\frac{1}{2}$ "H component worksurface over a 21 $\frac{1}{2}$ "H low credenza unit. 1 $\frac{1}{8}$ " thick. Handed design (left and right models). Includes cord routing notch. Bottom of end panel is edgebanded for added strength and to seal out moisture. Attaches to underside of worksurface via cam fasteners and L-bracket; attaches to top of low credenza with double-sided tape. Can be specified in a woodgrain or solid laminate color only. For 7"H metal O-leg support see page 94.

SPECIFYING EXAMPLE: HNLEP307R.H

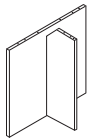

Not available in
two-tone laminate

T-shaped End Panel

11 $\frac{5}{8}$ "W x 29 $\frac{7}{8}$ "D x 28 $\frac{1}{2}$ "H	H10530TEP	45	3.7	\$265	\$277
11 $\frac{5}{8}$ "W x 23 $\frac{7}{8}$ "D x 28 $\frac{1}{2}$ "H	H10524TEP	38	3.2	\$248	\$260

NOTES: Non-handed. For use with 30"D and 24"D 10500 Series worksurfaces. Two 1 $\frac{1}{8}$ " thick pieces; one end and one brace panel. Cord routing notch in brace panel. Simple assembly.

⚠ Not designed to be used freestanding.

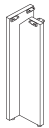

Not available in
two-tone laminate

T-Support Brace

8"W x 23 $\frac{3}{4}$ "D x 28 $\frac{1}{2}$ "H	H10524TSUPP	14	0.8	\$224	\$239
---	--------------------	----	-----	--------------	--------------

NOTES: Intermediate support option for 29 $\frac{1}{2}$ "H workstations. Designed for 24"D and 30"D worksurfaces without a modesty or back panel, with an unsupported span greater than 48"W. Can be used to support the junction of two 24"D adjoining linear worksurfaces. Adjustable hex glides allow floor-standing units to be easily leveled without lifting to compensate for uneven floors; glides have $\frac{3}{4}$ " adjustable range. Simple assembly.

NOTES:

- Adjustable hex leveling glides allow floor-standing furniture to be easily leveled without lifting the unit; glides have $\frac{3}{4}$ " adjustable range.

⚠ Laminate L- and T-shaped end panels can be specified as one color only; not available in two-tone laminate combination or in a pattern laminate.

HOW TO SPECIFY

Select Model Number	Select Laminate
H 1 0 5 3 0 T E P .	See pages 236-237
N	



10500 SERIES™ Worksurface Supports



DESCRIPTION

Support Column for 10500 Series Rectangle and Bullet Worksurfaces

4½" Diameter
For **Black**, specify HPC190X.P.
For **Silver**, specify HPC191X.X.

MODEL SHIP WEIGHT CUBE LIST PRICE

HPC190X	12 Ⓞ	1.0	\$161
HPC191X	12 Ⓞ	1.0	\$161

NOTES: Can only be used as the outbound support in a peninsula or island extension worksurface application. Glides have ¾" adjustable range.

! Support column must be specified for worksurfaces used as peninsulas or as an island extension.



DESCRIPTION

Post Leg Base
28½"H x 2" square

MODEL SHIP WEIGHT CUBE LIST PRICE BY PAINT GRADE

HLSL28P	15	1.0	\$292	\$296	\$312
----------------	----	-----	--------------	--------------	--------------

NOTES: Can only be used as the outbound support in a peninsula or island extension worksurface application. Glides have 2" of adjustability. Ship 1/pack.

! Post leg can only be used to support peninsula, not as primary supports for a top.

SPECIFYING EXAMPLE: HLSL28P.T1

24"D Rectangle Worksurface Support Options				
Product Application	Support Combination		Support Model Numbers for 72"W, 66"W, or 60"W Worksurfaces	Support Model Numbers for 48"W or 42"W Worksurfaces
	Support 1	Support 2		
Desk or Credenza	O-Leg	O-Leg	HLSL24280 (2)	HLSL24280 (2)
	O-Leg	L-Shaped End Panel	HLSL24280 / H10524LEP	HLSL24280 / H10524LEP
	L-Shaped End Panel	L-Shaped End Panel	H10524LEP (2)	H10524LEP (2)
	T-Shaped End Panel	O-Leg	H10524TEP / HLSL24280	H10524TEP / HLSL24280
	T-Shaped End Panel	L-Shaped End Panel	H10524TEP / H10524LEP	H10524TEP / H10524LEP
Peninsula for U- or L-Configuration; Not Freestanding	O-Leg	4½" Diameter Support Column	HLSL24280 / HPC190X-191X	NA
	O-Leg	2" Square Post Leg	HLSL24280 / HLSL28P	NA
	L-Shaped End Panel	4½" Diameter Support Column	H10524LEP / HPC190X-191X	NA
	L-Shaped End Panel	2" Square Post Leg	H10524LEP / HLSL28P	NA
	T-Shaped End Panel	4½" Diameter Support Column	H10524TEP / HPC190X-191X	NA
Desk, Credenza, or Freestanding Return or Bridge	Adjustable Height Base - Electric		HHAB3S2L	HHAB3S2L (48"W min.)
Return (requires one support)	O-Leg	—	HLSL24280	HLSL24280
	L-Shaped End Panel	—	H10524LEP	H10524LEP
	T-Shaped End Panel	—	H10524TEP	H10524TEP
	4½" Diameter Support Column	—	HPC190X or HPC191X	HPC190X or HPC191X
	2" Square Post Leg	—	HLSL28P	HLSL28P
Island Extension (requires one support)	O-Leg	—	HLSL24280	HLSL24280
	4½" Diameter Support Column	—	HPC190X or HPC191X	HPC190X or HPC191X
	2" Square Post Leg	—	HLSL28P	HLSL28P

72"W, 66"W, or 60"W x 30"D Bullet Worksurface Support Options			
Product Application	Support Combination		Support Model Numbers
	Support 1	Support 2	
Peninsula for U- or L-Configuration; Not Freestanding	O-Leg	4½" Diameter Support Column	HLSL30280 / HPC190X or HPC191X
	O-Leg	2" Square Post Leg	HLSL30280 / HLSL28P
	L-Shaped End Panel	4½" Diameter Support Column	H10530LEP / HPC190X or HPC191X
	L-Shaped End Panel	2" Square Post Leg	H10530LEP / HLSL28P
	T-Shaped End Panel	4½" Diameter Support Column	H10530TEP / HPC190X or HPC191X
	T-Shaped End Panel	2" Square Post Leg	H10530TEP / HLSL28P
Island Extension	4½" Diameter Support Column	—	HPC190X or HPC191X
	2" Square Post Leg	—	HLSL28P

HOW TO SPECIFY

Select Model Number

HPC190X.

Select Paint Color

See page 171

T1



10500 SERIES™ Worksurface Supports

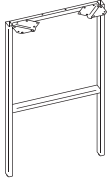

DESCRIPTION	MODEL	SHIP WEIGHT	CUBE	LIST PRICE BY PAINT GRADE		
				P1	P2	P3
H-Leg Support for Worksurfaces 30"W x 28 ³ / ₈ "H 24"W x 28 ³ / ₈ "H	H105HLEG3028	13.6	5.1	\$352	\$356	\$372
	H105HLEG2428	12.5	3.7	\$316	\$320	\$336
Standing-Height H-Leg Support for Worksurfaces 30"W x 41"H 24"W x 41"H	H105HLEG3041	16.5	6.5	\$474	\$482	\$494
	H105HLEG2441	15.4	5.3	\$424	\$432	\$444

NOTES:

• Legs ship fully assembled with mounting hardware, 1 per pack. Non-handed. H-leg glides have 2" adjustability. Will have 6" overhang when using 30"D H-legs with a 36"D worksurface.

❗ The H-leg attachment bracket interferes with placement of 10500 Series™ modular pedestals and 28³/₈"H mobile pedestals, preventing them from being positioned directly next to (flush with) the H-leg. Box/File mobile pedestal model H105106 and mobile printer/fax cart model H105679 can be positioned along side the H-leg.

❗ O- and H-legs may only be attached to worksurfaces, not storage units.

HOW TO SPECIFY

<p>Select Model Number</p> <p>H 1 0 5 H L E G 2 4 4 1 . T 1</p>	<p>Select Paint Color</p> <p>See page 171</p>
---	---

10500 SERIES™ Worksurface Supports

GSA SIN 33721 EXCEPT AS NOTED

ABI

Icon Legend on page 19

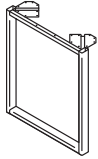
**DESCRIPTION****O-Leg**

30"D x 28½"H
24"D x 28½"H

MODEL

HLSL30280
HLSL24280

SHIP WEIGHT

19.0
17.0

CUBE

5.4
3.7

LIST PRICE BY PAINT GRADE

P1	P2	P3
\$352	\$356	\$372
\$316	\$320	\$336

NOTES: Ship fully assembled with mounting hardware, 1/pack. Non-handed. O-leg glides have 2" adjustability. Shared O-legs create a cleaner aesthetic in all applications where two legs are used side-by-side. Will have 6" overhang when using 30"D O-legs with a 36"D worksurface.

IMPORTANT: The O-leg attachment bracket interferes with placement of 10500 Series modular pedestals and 28¾"H mobile pedestals, preventing them from being positioned directly next to (flush with) the O-leg. Box/file mobile pedestal (model H105106) and mobile printer/fax cart model (H105679) can be positioned along side the O-leg.

! O-legs may only be attached to worksurfaces, not storage units.

SPECIFYING EXAMPLE: HLSL24280.T1

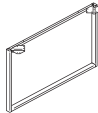
**Double-Depth O-Leg Support for Worksurfaces**

60"D x 28½"H
48"D x 28½"H

HLSL60280
HLSL48280

19.0
18.0

8.7
7.0

\$665	\$673	\$685
\$597	\$605	\$617

NOTES: Ship fully assembled with mounting hardware, 1/package. Non-handed. 48"D and 60"D sizes span back-to-back 24"D and 30"D worksurfaces, respectively. O-leg glides have 2" adjustability. Shared O-legs create a cleaner aesthetic in all applications where two legs are used side-by-side. Will have 6" overhang when using 30"D O-legs with a 36"D worksurface.

! O-legs may only be attached to worksurfaces, not storage units.

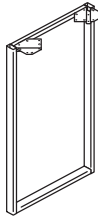
**Standing-Height O-Leg Support for Worksurfaces**

30"D x 41"H
24"D x 41"H

HLSL30410
HLSL24410

17.0
16.0

6.5
5.3

\$474	\$480	\$494
\$424	\$430	\$444

NOTES: Ship fully assembled with mounting hardware, 1/package. Non-handed. O-leg glides have 2" adjustability. O-leg installation requires 6" of clearance from the worksurface end. Shared O-legs create a cleaner aesthetic in all applications where two legs are used side-by-side. Will have 6" overhang when using 30"D O-legs with a 36"D worksurface.

Coordinate™ Power Modules will work with standing-height applications for 10500™ and Voi® desks.

! O-legs may only be attached to worksurfaces, not storage units.

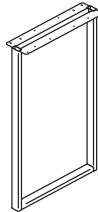
**Standing-Height O-Leg Shared Support for Worksurfaces**

30"D x 41"H
24"D x 41"H

HLSL3041SL
HLSL2441SL

17.0
16.0

6.5
5.3

\$529	\$535	\$549
\$478	\$484	\$498

NOTES: Ship fully assembled with mounting hardware, 1/package. Non-handed. For use with two 24"D or 30"D worksurfaces positioned side-by-side along the depth dimension. O-leg glides have 2" adjustability. O-leg installation requires 6" of clearance from the worksurface end. Shared O-legs create a cleaner aesthetic in all applications where two legs are used side-by-side. Will have 6" overhang when using 30"D O-legs with a 36"D worksurface.

Coordinate™ Power Modules will work with standing-height applications for 10500™ and Voi® desks. Please see Coordinate™ Accessories Stand-Alone Pricer pages for more information.

! O-legs may only be attached to worksurfaces, not storage units.



OPEN MARKET

O-Leg Cord Clips

Clips for 28½" Worksurface O-Legs — 8-Pack

HWMCLIPG

0.8 ☹

0.1

\$99**N/A****N/A**

NOTES: Wire clips work with 7" Low Credenza O-leg and 29"H Support O-leg. Wire clips also work with the 50" and 65" Hutch O-legs. For additional information see page 852.

! Available in frosted plastic material only.

NOTES:

! For shared components such as modesty panels and Privacy Screens see pages 199-201.

HOW TO SPECIFY

Select
Model Number

Select
Paint Color

See page 171



HLSL30280

T1

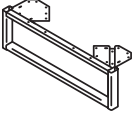
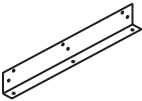

Icon Legend on page 19

10500 SERIES™ Worksurface Supports

	DESCRIPTION	MODEL	SHIP WEIGHT	CUBE	LIST PRICE BY PAINT GRADE		
					P1	P2	P3
	O-Leg Shared Support for Worksurfaces						
	30"D x 28½"H 24"D x 28½"H	HLSL3028SL HLSL2428SL	19 17	5.4 3.7	\$438 \$394	\$442 \$398	\$458 \$414
	NOTES: Ship fully assembled, 1/pack. Non-handed. ! Specify paint only. SPECIFYING EXAMPLE: HLSL2028SL.T1						
	O-Leg Support for Low Credenzas						
	30"D x 7"H 24"D x 7"H	HLSL3070 HLSL2470	7 6	1.0 1.0	\$271 \$213	\$275 \$217	\$291 \$233
	NOTES: Ship fully assembled, 1/pack. Non-handed. For 7"H laminate support see page 92. ! Specify paint only. SPECIFYING EXAMPLE: HLSL2070.T1						
 <i>HVPWLBK24 shown</i>	Worksurface Wall Mount Bracket						
	For 30" For 24"	HVPWLBK30 HVPWLBK24		2 2	0.3 0.3	\$83 \$76	
OPEN MARKET	NOTES: Can be used in place of an end panel or O-leg to support a worksurface. Cannot be used as a support when placing a stack-on storage unit on worksurface over bracket; must have two full-sized floor supports when using stack-on storage. Finish option not required. SPECIFYING EXAMPLE: HVPWLBK30						
	Worksurface to Tower Bracket Kit						
	18½" long bracket for attaching 24"D worksurface directly to storage tower, wardrobe/bookcase, wardrobe/storage cabinet, storage cabinet/lateral file, storage cabinet, or lateral file.	HSTB2W1	4	0.6	\$76	\$89	\$100
	NOTES: Can be used in place of end panel or O-leg to support worksurfaces. ! Bracket not designed for use as a support if placing Stack-on Storage on worksurface over/above bracket. Two full-sized supports required when using Stack-on Storage.						

NOTES:

- O-leg glides have 2" adjustability.
- For shared components such as modesty panels and Privacy Screens see pages 199-201.
- O-leg ships fully assembled with mounting hardware.
- For standing-height O-leg sizes, see page 252.
- Shared O-legs create a cleaner aesthetic in all applications where two legs are used side-by-side.
- Will have 6" overhang when using 30"D O-legs with a 36"D worksurface.

- ! O-legs may only be attached to worksurfaces, not storage units.
- ! O-leg installation requires 6" of clearance from the worksurface end.

HOW TO SPECIFY

<p>Select Model Number</p> <p>HVPWLBK30</p>	<p>Select Paint Color</p> <p>See page 171</p> <p>T1</p>
---	---

10500 SERIES™

Components — Supports

GSA SIN 33721

ABI

Icon Legend on page 19

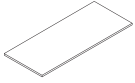
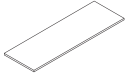
	DESCRIPTION	MODEL	SHIP WEIGHT	CUBE	LIST PRICE BY LAMINATE GRADE	
					L1	L2
	Rectangle Worksurface					
	72"W x 30"D	H105R3072	83	6.1	\$402	\$422
	66"W x 30"D	H105R3066	76	6.1	\$374	\$394
	60"W x 30"D	H105R3060	69	5.2	\$349	\$369
	48"W x 30"D	H105R3048	55	4.1	\$286	\$301
	72"W x 24"D	H105R2472	66	4.9	\$342	\$362
	66"W x 24"D	H105R2466	61	4.9	\$331	\$351
	60"W x 24"D	H105R2460	55	4.2	\$311	\$331
	48"W x 24"D	H105R2448	44	3.4	\$264	\$279
	42"W x 24"D	H105R2442	39	3.0	\$239	\$254

NOTES: Underside of rectangle worksurfaces includes pilot mounting holes for end panels, support columns, post and O-legs, and height adjustable base. Applications for 24"D worksurfaces include desks, credenzas, returns, and bridges. The 42"W x 24"D size is not compatible with Height Adjustable Base model HHAB3S2L; it can however, be used in combination with the 72"W x 30"D worksurface on 3-Leg Height Adjustable Base model HHAB3S3L. For Above Privacy Screen sizes, see page 201.

NOTES:

- Height Adjustable Base is a 3-stage column design.
 - Frame rises from 21 $\frac{5}{8}$ " to 47 $\frac{3}{4}$ " for a sit-to-stand desk option.
 - Height Adjustable Bases shipped complete with a pre-assembled motor.
 - Base telescopes to accommodate any worksurface between 48"W and 72"W.
 - Height Adjustable Base accommodates rectangular worksurfaces between 24"D x 48"W and 30"D x 72"W. Systems, Voi®, 10500, and Preside® all have worksurfaces within this range.
 - Comes standard with one-touch, four memory controller with digital display; no specification needed, available in black finish only.
 - Standard height adjustable control ships with base.
 - Dynamic load capacity when worksurface is moving is 250 lbs.
- ⓘ Worksurfaces used with Coordinate™ Height Adjustable Bases should have 1" perimeter gap on each side to provide clearance between other furniture. Failure to do so risks injury or product damage (not covered by warranty).

HOW TO SPECIFY

Select Model Number

H 1 0 5 R 3 0 7 2 .

Select Laminate

See pages 236-237

N N



10500 SERIES™ Height Adjustable Bases

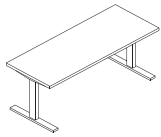

Base shown with worksurface attached.

OPEN MARKET

DESCRIPTION

MODEL

SHIP WEIGHT

CUBE

LIST PRICE

Coordinate™ Height Adjustable Base – 3 Stage
24”D Feet and Worksurface Brackets

HHAB3S2L

67.0

2.4

\$1120

NOTES: Base is a dual motor 3-stage design with standard anti-collision. Legs raise from 21⁵/₈” to 47³/₄”. Base telescopes to accommodate any rectangular worksurface between 24”D x 48”W and 30”D x 72”W. Supports weight capacity of 250 lbs. (excluding worksurface weight). Foundation™, Systems, Voi®, 10500, and Preside® all have worksurfaces within this range. Comes standard with one-touch, four memory controller with digital display; no specification needed, available in black finish only. UL Certified. **HON 5-Year Limited Warranty.**

ⓘ Telescoping horizontal frame will extend just over 2” from underside of the worksurface.

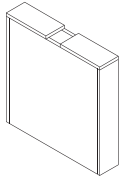

Not available in two-tone laminate.

SIN 33721

Shroud for Height Adjustable Base

5¹/₈”W x 26”D x 26¹/₄”H for Base with 30”D Top

HLAMSHB30

39.0

3.7

\$848

NOTES: Decorative laminate enclosure covers the Coordinate™ metal leg and foot. Lowest base adjustment position when the shroud is installed is 29¹/₂”H; memory controller must be set at that height to avoid interference. For use with standard 10500 Series™, Concinity™, and Voi® rectangle worksurfaces, 48-72”W x 30”D, supported by Height Adjustable Base models HHAB3S2L or HHAB2S2L. For height adjustable desks requiring a modesty panel, options include: 14”H laminate (HLSLXX14L) or mixed material (HLSLXX14MM) floating modesty panels, laminate full length (HNLMPXX28) or short (HNLMPXX10) modesty/back panel plus external support channel (HLSLZ5SCXX). External support channel attachment screws and modesty/back panel cover caps are included in the shroud hardware pack. External support channel size recommendation, specific to worksurface attached to Height Adjustable Base with optional laminate full-length or short modesty back/panel (HNLMPXX28/10) see below. Ships one per carton. To conceal both metal legs on the Height Adjustable Base order two.

Specify: Model.Laminate; see pages 236-237.

SPECIFYING EXAMPLE: HLAMSHB30.N

ⓘ The Height Adjustable Base must be reset at the time of installation, after every loss of power, if the unit is not functioning properly, or if the legs are uneven. To reset the base requires removing the laminate shroud(s), as well as the full-length modesty panel if one is being used, then adjusting the base to its lowest position. Disassembly of the shroud is quick and easy.

ⓘ \$25 upcharge for L2 laminates.

Worksurface Width	Modesty/Back Panel Width	External Support Channel
72”W	72”W	HLSLZ5SC78
66”W	66”W	HLSLZ5SC72
60”W	60”W	HLSLZ5SC66
54”W	54”W	HLSLZ5SC60
48”W	48”W	HLSLZ5SC54

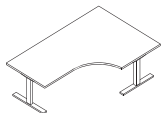

Base shown with worksurface attached.

OPEN MARKET

Coordinate™ 3-Leg Height Adjustable Base – 3 Stage

24”D Feet and Worksurface Brackets

HHAB3S3L

91.0

3.6

\$1896

NOTES: Base is a three motor 3-stage design with standard anti-collision. Legs raise from 21⁵/₈” to 47³/₄”. **The 3-leg base supports corner coves or two-piece worksurfaces 41”-72”W x 35”-72”L x 23¹/₄”-30”D. 48”W 120 degree corner worksurfaces are also supported. When using two worksurfaces, the connection between the two must be over the telescoping frame. Supports weight capacity of 375 lbs.** (excluding worksurface weight). Can be used with 48” 120 degree and worksurface models. Comes standard with one-touch, four memory controller with digital display; no specification needed, available in black finish only. UL Certified. **HON 5-Year Limited Warranty.**

ⓘ When using two worksurfaces, a flat bracket is required. Bracket purchased separately – HHN831124, HHN831130 – see page 589.

ⓘ Telescoping horizontal frame will extend just over 2” from underside of the worksurface.

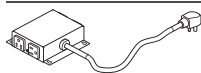

SIN 33721

Under Worksurface Power Module – 4 Outlets, 10’ Cord

HPWRMOD2

1.5

0.2

\$401

- Includes 10’ cord with three-prong plug.
- Fits in cable management troughs. See page 232.
- 4 outlets on side create easy access.

NOTES: Power Modules will also work with standing-height applications for 10500 Series™ and Voi® desks. For additional information see page 849.

ⓘ Available in black finish only, no specification needed.

NOTES:

ⓘ Coordinate™ Height Adjustable Bases not compatible with 36”D rectangular worksurfaces.

HOW TO SPECIFY

Select Model Number

HHAB3S2L

Select Finish

P71 Black
P8L Nickel
PDB White

P8L

10500 SERIES™

Shared Components

GSA SIN 33721



Icon Legend on page 19

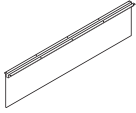

DESCRIPTION	MODEL	SHIP WEIGHT	CUBE	LIST PRICE BY LAMINATE GRADE	
				L1	L2
Laminate Floating Modesty Panel					
60"W x 14"H	HLSL6014L	20	1.1	\$250	\$262
54"W x 14"H	HLSL5414L	18	1.1	\$232	\$244
48"W x 14"H	HLSL4814L	16	1.1	\$212	\$224
42"W x 14"H	HLSL4214L	14	0.8	\$193	\$203
36"W x 14"H	HLSL3614L	12	0.8	\$179	\$189
30"W x 14"H	HLSL3014L	10	0.8	\$169	\$179

NOTES: The attachment bracket and modesty panel are packaged separately.

Specify: Model.Laminate.Paint

SPECIFYING EXAMPLE: HLSL3014L.N.P (Black is the only paint option for this model)

⚠ When specifying the 54"W or 60"W Laminate Floating Modesty Panel, it is not necessary to specify an external channel.

⚠ 30"W and 36"W screens attach with L-brackets, not the external channel.

NOTES:

- Laminate or mixed material floating modesty panels options are available for attachment under 10500 Series worksurfaces. The modesty panel and attachment bracket are packaged separately.
- If using a 54"W or 60"W floating modesty panel, it is not necessary to specify an external support channel under the worksurface.
- When using a floating modesty panel under the worksurface, the depth clearance for center drawers and keyboard platforms decreases by 8".

FLOATING MODESTY PANELS - MODEL SELECTION GUIDE						
Support Combination		Rectangle Worksurface Width				
Support 1	Support 2	72 in	66 in	60 in	48 in	42 in
O-Leg	O-Leg	HLSL6014	HLSL5414	HLSL4814	HLSL3614	HLSL3014
O-Leg	L-Shaped End Panel	HLSL4814	HLSL4214	HLSL3614	NA	NA
O-Leg	4½" Diameter Support Column	HLSL4814	HLSL4814	HLSL4814	HLSL3614	HLSL3014
O-Leg	2" Square Post Leg	HLSL4814	HLSL4814	HLSL4814	HLSL3614	HLSL3014
L-Shaped End Panel	L-Shaped End Panel	HLSL3614	HLSL3014	NA	NA	NA
L-Shaped End Panel	4½" Diameter Support Column	HLSL3614	HLSL3614	HLSL3614	NA	NA
L-Shaped End Panel	2" Square Post Leg	HLSL3614	HLSL3614	HLSL3614	NA	NA
T-Shaped End Panel	O-Leg	HLSL5414	HLSL4814	HLSL4214	HLSL3014	NA
T-Shaped End Panel	L-Shaped End Panel	HLSL3614	HLSL3014	NA	NA	NA
T-Shaped End Panel	4½" Diameter Support Column	HLSL3614	HLSL3014	NA	NA	NA
T-Shaped End Panel	2" Square Post Leg	HLSL3614	HLSL3014	NA	NA	NA

Support Combination		Bullet Worksurface Width		
Support 1	Support 2	72 in	66 in	60 in
O-Leg	4½" Diameter Support Column	HLSL4814	HLSL4814	HLSL4814
O-Leg	2" Square Post Leg	HLSL4814	HLSL4814	HLSL4814
L-Shaped End Panel	4½" Diameter Support Column	HLSL3614	HLSL3614	HLSL3614
L-Shaped End Panel	2" Square Post Leg	HLSL3614	HLSL3614	HLSL3614
T-Shaped End Panel	4½" Diameter Support Column	HLSL3614	HLSL3614	HLSL3614
T-Shaped End Panel	2" Square Post Leg	HLSL3614	HLSL3614	HLSL3614

HOW TO SPECIFY

Select Model Number

H L S L 3 0 1 4 L . N

Select Laminate

See pages 236-237



10500 SERIES™

Shared Components

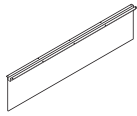
**DESCRIPTION****Mixed Material Floating Modesty Panel**

60"W x 14"H
54"W x 14"H
48"W x 14"H
42"W x 14"H
36"W x 14"H
30"W x 14"H

MODEL

HLSL6014MM
HLSL5414MM
HLSL4814MM
HLSL4214MM
HLSL3614MM
HLSL3014MM

SHIP WEIGHT

13
13
11
9
8
8

CUBE

3.3
3.3
2.6
2.3
2.0
2.0

LIST PRICE

\$1113
\$974
\$898
\$811
\$726
\$676

NOTES: The attachment bracket and modesty panel are packaged separately. Laminate or mixed material floating modesty panels options are available for attachment under 10500 Series worksurfaces. The modesty panel and attachment bracket are packaged separately. If using a 54"W or 60"W floating modesty panel, it is not necessary to specify an external support channel under the worksurface. When using a floating modesty panel under the worksurface, the depth clearance for center drawers and keyboard platforms decreases by 8". See charts on previous page.

Specify: Model.Mixed Material.Paint

SPECIFYING EXAMPLE: HLSL3014MM.FT01.P (Frosted Translucent mixed material and Black paint are the only options for this model)

! When specifying the 54"W or 60"W Mixed Material Floating Modesty Panel, it is not necessary to specify an external channel.

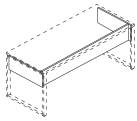

Not available in two-tone laminate

Modesty Panels for Desks with O-Legs

68³/₈"W x 3¹/₄"D x 10"H — For 72" x 30" Desks
56³/₈"W x 3¹/₄"D x 10"H — For 60" x 30" Desks

HLAMMP7230
HLAMMP6030

26
23

2.1
1.8

\$289
\$264

NOTES: For use with 60"W or 72"W worksurfaces supported by O-legs. Comprised of three panels: one approach side and one for each end. Length below bottom of worksurface is 10". Steel external support channel (ordered separately) is recommended for unsupported spans greater than 54"W (i.e.: a distance in which there is not a vertical support between the underside of the worksurface and floor). Grain direction is vertical on approach and side panels for 56³/₈"W (all laminate colors) and 68³/₈"W (L1 laminate except Florence Walnut and Kingswood Walnut). Vertical on 27⁵/₈" end panels (all laminate colors). Horizontal on all panels for L2 laminates as well as Florence Walnut and Kingswood Walnut.

Specify: Model.Laminate

SPECIFYING EXAMPLE: HLAMMP7230.N

! \$15 upcharge for L2 laminates. See pages 236-237 for laminate options.

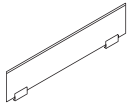
**Above Privacy Screen**

60"W x 13"H
54"W x 13"H
48"W x 13"H
42"W x 13"H
36"W x 13"H
30"W x 13"H

HLSL1260
HLSL1254
HLSL1248
HLSL1242
HLSL1236
HLSL1230

24
22
20
18
15
13

2.9
2.9
2.3
2.3
1.8
1.5

\$453
\$421
\$394
\$344
\$308
\$279

NOTES: Ships complete with attachment bracket. Bracket is Platinum only, no need to specify. Attaches to top of rectangle worksurfaces; requires a minimum overhang of 1¹/₂".

! Available in Frosted Glass ONLY HLSL1230.G.

! Above only Privacy Screen clamps onto worksurface and cannot be installed where support storage will be attached.

HOW TO SPECIFY

Select
Model Number

HLSL3014MM.

Select
Mixed Material

FT01 Frosted Translucent

FT01



10500 SERIES™

Laminate Modular Components

GSA SIN 33721

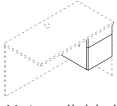

Icon Legend on page 19

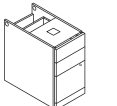
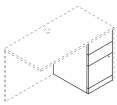
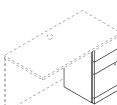
	DESCRIPTION	MODEL	SHIP WEIGHT	CUBE	LIST PRICE BY LAMINATE GRADE	
					L1	L2
 Not available in two-tone laminate	Box/File Pedestal (with core removable lock) 15 $\frac{5}{8}$ "W x 22 $\frac{3}{4}$ "D x 17 $\frac{3}{4}$ "H — for use under 24"D, 30"D and 36"D desk, credenza and return shells NOTES: Attaches to underside of worksurface top. Lock can be positioned on either the right or left side. File drawer includes integrated hangrails for letter- or legal-sized folders. Not for use under 20"D shells. ⓘ Not designed to be used freestanding. Unfinished top and back.	H10501	57	5.5	\$523	\$543
 Not available in two-tone laminate	Narrow Box/Box/File Pedestal (with core removable lock) — floor-standing 9 $\frac{1}{2}$ "W x 22 $\frac{3}{4}$ "D x 28"H — for use under 24"D, 30"D and 36"D desk, credenza and return shells NOTES: Space-saving design supports smaller footprints. Middle box drawer and file drawer lock; top box drawer does not lock. File drawer includes integrated hangrails for side-to-side letter or legal filing. Not for use under 20"D shells. ⓘ Not designed to be used freestanding. Unfinished top and back.	H105093	61	5.6	\$676	\$701
 Not available in two-tone laminate	Box/Box/File Pedestal — floor-standing 15 $\frac{5}{8}$ "W x 28 $\frac{3}{4}$ "D x 28"H — for use under 10500 Series 30"D worksurfaces supported by 29 $\frac{7}{8}$ "D L-shaped end panel model H10530LEP NOTES: Top box drawer does not lock. File drawer includes integrated hangrails for letter- or legal-sized folders. Not for use under shells, per "Inside Dimensions" listings. ⓘ Not designed to be used freestanding. Unfinished top and back.	H105062	105	10.5	\$743	\$773
 Not available in two-tone laminate	Box/Box/File Pedestal (with core removable lock) — floor-standing 15 $\frac{5}{8}$ "W x 22 $\frac{3}{4}$ "D x 28"H — for use under 24"D, 30"D and 36"D desk, credenza and return shells or worksurface supported by 23 $\frac{7}{8}$ "D L-shaped end panel(s) NOTES: Top box drawer does not lock. File drawer includes integrated hangrails for letter- or legal-sized folders. Not for use under 20"D shells. ⓘ Not designed to be used freestanding. Unfinished top and back.	H10502	90	8.4	\$686	\$711
 Not available in two-tone laminate	Box/Box/File Pedestal (with core removable lock) — floor-standing 15 $\frac{5}{8}$ "W x 18 $\frac{3}{4}$ "D x 28"H — for use under 20"D, 24"D, 30"D and 36"D desk, credenza and return shells NOTES: Top box drawer does not lock. File drawer includes integrated hangrails for letter- or legal-sized hanging folders. ⓘ Not designed to be used freestanding. Unfinished top and back.	H105012	73	7.3	\$647	\$667

NOTES:



- Pedestals can be reconfigured quickly and easily when user preferences or space needs change.
 - Locking units equipped with interchangeable core removable locks.
 - Pedestal models ship assembled unless designated .
 - Mobile pedestals shown on page 276, work well in a variety of configurations.
 - Narrow Pedestal features a compact design that is ideal for use in U- and L-shaped layouts for smaller spaces such as a 5' x 8' U-shaped workstation or a 5' x 5' L-shaped workstation.
 - 10500 Series™ modular pedestals are for use with desk, credenza and return shells (see pages 244-248), as well as L-shaped end panels (page 250).
- ⓘ Keyed alike cores must be ordered separately — see model HF23B on page 853 — makes re-keying quick and easy.
- ⓘ Access strip (filler) required when box/box file, file/file, and/or narrow box/box/file pedestals are configured side-by-side to allow access for opening the drawers.
- ⓘ Modular pedestals can be specified as one color only; not available in two-tone laminate combination or in a pattern laminate.

HOW TO SPECIFY

Select Model Number <input type="text" value="H105093"/>	Select Laminate Chassis Color <input type="text" value="N"/>
See pages 236-237	

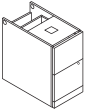
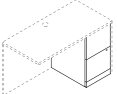
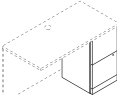

10500 SERIES™ Laminate Modular Components

	DESCRIPTION	MODEL	SHIP WEIGHT	CUBE	LIST PRICE BY LAMINATE GRADE	
					L1	L2
 Not available in two-tone laminate	File/File Pedestal — floor-standing 15 ⁵ / ₈ "W x 28 ³ / ₄ "D x 28"H — for use under 10500 Series 30"D worksurfaces supported by 29 ⁷ / ₈ "D L-shaped end panel model H10530LEP NOTES: File drawer includes integrated hangrails for letter- or legal-sized folders. Not for use under shells, per "Inside Dimensions" listings. ! Not designed to be used freestanding. Unfinished top and back.	H105064	104	10.5	\$743	\$773
 Not available in two-tone laminate	File/File Pedestal (with core removable lock) — floor-standing 15 ⁵ / ₈ "W x 22 ³ / ₄ "D x 28"H — for use under 24"D, 30"D and 36"D desk, credenza and return shells or worksurface supported by 23 ⁷ / ₈ "D L-shaped end panel(s) NOTES: File drawers include integrated hangrails for letter- or legal-sized folders. Not for use under 20"D shells. ! Not designed to be used freestanding. Unfinished top and back.	H10504	85	8.2	\$686	\$711
 Not available in two-tone laminate	File/File Pedestal (with core removable lock) — floor-standing 15 ⁵ / ₈ "W x 18 ³ / ₄ "D x 28"H — for use under 20"D, 24"D, 30"D and 36"D desk, credenza and return shells NOTES: File drawers include integrated hangrails for letter- or legal-sized folders. ! Not designed to be used freestanding. Unfinished top and back.	H105014	72	7.3	\$647	\$667
 Not available in two-tone laminate	Access Strip (Filler) 1 ¹ / ₈ "W x 20 ¹ / ₂ "D x 28"H NOTES: For use under 24"D, 30"D and 36"D desk, credenza or return shells when B/B/F, F/F, and or narrow B/B/F pedestals are configured side-by-side. Not required when pedestals are used in conjunction with lateral file pedestals, multi file pedestals or cabinet pedestal. Not sized for use with 20"D modular shells. NOTE: See pages 244-248 for desk, credenza and return shells.	H10524	21	0.9	\$176	\$186

NOTES:

- Pedestals can be reconfigured quickly and easily when user preferences or space needs change.
- Locking units equipped with interchangeable core removable locks.
- Pedestal models ship assembled unless designated .
- Mobile pedestals shown on page 276, work well in a variety of configurations.
- Narrow Pedestal features a compact design that is ideal for use in U- and L-shaped layouts for smaller spaces such as a 5' x 8' U-shaped workstation or a 5' x 5' L-shaped workstation.
- 10500 Series™ modular pedestals are for use with desk, credenza and return shells (see pages 244-248), as well as L-shaped end panels (page 250).
- ! Keyed alike cores must be ordered separately — see model HF23B on page 853 — makes re-keying quick and easy.
- ! Access strip (filler) required when box/box file, file/file, and or narrow box/box/file pedestals are configured side-by-side to allow access for opening the drawers.
- ! Modular pedestals can be specified as one color only; not available in two-tone laminate combination or in a pattern laminate.

HOW TO SPECIFY
Select Model Number

H 1 0 5 0 4 .

Select Laminate Chassis Color

See pages 236-237

N

10500 SERIES™

Laminate Modular Components

GSA SIN 33721



Icon Legend on page 19

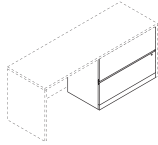

Not available in two-tone laminate

DESCRIPTION	MODEL	SHIP WEIGHT	CUBE	LIST PRICE BY LAMINATE GRADE	
				L1	L2
Lateral File Pedestal (with core removable lock) — Floor-standing 36"W x 20"D x 28"H — For use under 24"D, 30"D and 36"D desk, credenza and return shells NOTES: Drawers include integrated hangrails for letter- or legal-sized folders. Mechanical interlock inhibits extension of more than one drawer at a time. Not for use under 20"D shells. ! Not designed to be used freestanding. Unfinished top and back.	H10503	127	15.6	\$1042	\$1082

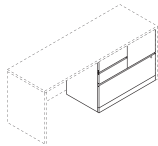

Not available in two-tone laminate

Multi File Pedestal (with core removable lock) — Floor-standing 36"W x 20"D x 28"H — For use under 24"D, 30"D and 36"D desk, credenza and return shells NOTES: Versatile four drawer unit features a lateral file, vertical file, and two box drawers. Box drawers do not lock. File drawers include integrated hangrails for letter- or legal-sized folders. Mechanical interlock in lateral drawer inhibits extension of more than one drawer at a time. Not for use under 20"D shells. ! Not designed to be used freestanding. Unfinished top and back.	H10505	155	15.6	\$1249	\$1289
--	---------------	-----	------	---------------	---------------

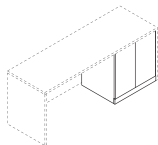

Not available in two-tone laminate

Cabinet Pedestal — Floor-standing 26"W x 21¼"D x 28"H — For use under 24"D, 30"D and 36"D desk, credenza and return shells NOTES: One adjustable shelf at 2½" increments. Doors are non-locking. Not for use under 20"D shells. ! Not designed to be used freestanding. Unfinished top and back.	H10508	78	12.2	\$777	\$817
--	---------------	----	------	--------------	--------------

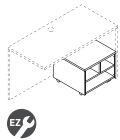

Mobile Printer/Fax Cart 20"W x 19¼"D x 14¼"H — For use under 24"D, 30"D and 36"D desk, credenza and return shells NOTES: Holds laser printers, inkjet printers or fax machines. Ideal for limited space. Low profile cart stores conveniently and easily under desks and workstations. Interior compartment shelving is Black. Four casters. Specify laminate top and chassis color. Not for use under 20"D shells. SPECIFYING EXAMPLE: H105679.NN	H105679	52	2.9	\$420	\$440
---	----------------	----	-----	--------------	--------------

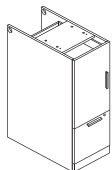

Not available in two-tone laminate

Box/Shelf/File Pedestal 15½"W x 28¾"D x 41"H — For 30"D worksurfaces 15½"W x 22¾"D x 41"H — For 24"D or 30"D worksurfaces NOTES: For 42"H standing-height desks. Designed to be used under a component worksurface supported on the pedestal end(s) by 41"H L-shaped end panel(s). For single pedestal workstations, the non-pedestal end can be supported by a 41"H L-shaped end panel, H-leg, or O-leg. Adjustable hex glides allow floor-standing units to be easily leveled without lifting to compensate for uneven floors; glides have ¼" adjustable range. Cabinet includes one box (supply) drawer and two shelves (one fixed, one adjustable); shelf adjusts in 1¼" increments with a range of 5". Not to be used freestanding, top and back are not enclosed. Pedestal depth is less than the depth of the respective component top to accommodate L-shaped end panel. File drawer includes integrated hangrails. Standard with linear handles in black finish.	H105077	104	14.7	\$1434	\$1489
	H105076	89	11.9	\$1384	\$1434

NOTES:

- Pedestals can be reconfigured quickly and easily when user preferences or space needs change.
- File drawers accept hanging folders in letter or legal size.
- Mobile pedestals shown on page 276, work well in a variety of configurations.
- Locking units equipped with interchangeable core removable locks.
- Pedestal models ship assembled unless designated
- See pages 244-248 for desk, credenza and return shells.

! Keyed alike cores must be ordered separately — see model HF23B on page 853 — makes re-keying quick and easy.

! Access strip (filler) required when box/box file, file/file, and/or narrow box/box/file pedestals are configured side-by-side to allow access for opening the drawers.

HOW TO SPECIFY

Select Model Number H 1 0 5 0 3 . N	Select Laminate Chassis Color See pages 236-237
---	---



10500 SERIES™

Laminate Wood Desks — Full Pedestals

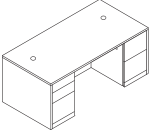
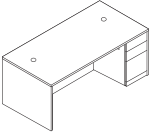
	DESCRIPTION	FULL WIDTH OVERHANG	MODEL	SHIP WEIGHT	CUBE	LIST PRICE BY LAMINATE GRADE		
						L1	L2	
	Double Pedestal Desk							
	72"W x 36"D x 29½"H, Bow Top, 3/2	10½"	H105899	315	50.9	\$1867	\$1947	
	72"W x 36"D x 29½"H, Rectangle Top, 3/2	10½"	H105890	340	50.9	\$1702	\$1777	
	66"W x 30"D x 29½"H, Rectangle Top, 3/2	4½"	H105891	290	39.4	\$1586	\$1651	
	60"W x 30"D x 29½"H, Rectangle Top, 3/2	4½"	H105892	278	35.9	\$1491	\$1551	
	NOTES: All drawers lock. Two cord grommets in top for routing and hiding wires and cables. Bow top models measure 36"D at crest and 30"D along the end panels. See page 282 for optional center drawers.							
	Single Pedestal Desk							
	72"W x 36"D x 29½"H, Bow Top, Right	10½"	H105893R	292	50.9	\$1530	\$1600	
	72"W x 36"D x 29½"H, Rectangle Top, Right	10½"	H105895R	278	50.9	\$1361	\$1431	
	66"W x 30"D x 29½"H, Rectangle Top, Right	4½"	H105897R	226	39.4	\$1229	\$1284	
	72"W x 36"D x 29½"H, Bow Top, Left	10½"	H105894L	292	50.9	\$1530	\$1600	
	72"W x 36"D x 29½"H, Rectangle Top, Left	10½"	H105896L	278	50.9	\$1361	\$1431	
	66"W x 30"D x 29½"H, Rectangle Top, Left	4½"	H105898L	226	39.4	\$1229	\$1284	
		NOTES: Box/box/file drawers. Drawers lock. Two cord grommets in top for routing and hiding wires and cables. Bow top models measure 36"D at crest and 30"D along the end panels. See page 282 for optional center drawers.						

NOTES:

- Factory-configured desks, credenzas and returns ship fully assembled for ease and speed of installation.
- Full-to-floor pedestals maximize storage space.
- Smooth, flat edges provide a clean look.
- Tops are easy-care, scratch-, spill- and stain-resistant laminate over 1⅞" solid core high-performance particleboard.
- 3" round cord management grommets, for routing and hiding wires and cables, are located in the tops of desks, returns, bridges, and corner units. Grommet cutout accepts optional Power Hub (model HGRMTAC) or Power/USB Hub (model HGRMTUSB2) — see page 287.
- For work-in-process paper management tools, see pages 282-283.
- Drawers operate on full extension, ball-bearing suspensions to ensure smooth, quiet, long-lasting operation.
- File drawer design includes integrated hangrails for side-to-side letter or legal filing; and front-to-back for letter filing.
- For field installable decorative handle options, see page 285.
- All drawers are five-sided construction for added strength and easy alignment or replacement of drawer fronts.
- Center drawers conveniently store writing instruments, paper and other miscellaneous items. Includes pencil tray. See page 288.

HOW TO SPECIFY

Select Model Number <input type="text" value="H105899"/>	Select Laminate Top and Chassis Color See pages 236-237 <input type="text" value="NN"/>
--	--

10500 SERIES™

Laminate Wood Desks — Full Pedestals

GSA SIN 33721



Icon Legend on page 19

	DESCRIPTION	FULL WIDTH OVERHANG	MODEL	SHIP WEIGHT	CUBE	LIST PRICE BY LAMINATE GRADE	
						L1	L2
	Return, file/file						
	48"W x 24"D x 29½"H, Right		H105905R	167	24.2	\$962	\$1002
	42"W x 24"D x 29½"H, Right		H105907R	147	21.4	\$941	\$981
	48"W x 24"D x 29½"H, Left		H105906L	167	24.2	\$962	\$1002
	42"W x 24"D x 29½"H, Left		H105908L	147	21.4	\$941	\$981
	NOTES: Return is for use with single pedestal desks, desk shells, peninsulas or corner units. One worksurface grommet and one cord pass-through grommet in top center of modesty panel to reach wall electrical outlets. Drawers lock. Not to be used freestanding. Will not attach to Corner Units manufactured prior to 5/24/99. See pages 269-270 for optional Stack-on Storage.						
	Credenza with Doors						
	72"W x 24"D x 29½"H	3½"	H105909	323	34.8	\$1762	\$1827
	NOTES: All drawers lock. Doors are non-locking. Includes a fixed shelf located at the bottom of the center storage area. No intermittent shelf. See pages 269-270 for optional Stack-on Storage.						
	Credenza with Kneespace, file/file						
	72"W x 24"D x 29½"H	3½"	H105900	274	34.8	\$1493	\$1553
	66"W x 24"D x 29½"H	3½"	H105901	262	32.0	\$1478	\$1538
	60"W x 24"D x 29½"H	3½"	H105902	248	29.2	\$1423	\$1478
	NOTES: All drawers lock. One cord pass-through grommet in top center of modesty panel to reach wall electrical outlets. Not designed for use with 22¾"D modular or mobile pedestals. Modesty/back panel is inset 3½". See pages 269-270 for optional Stack-on Storage.						
	Single Pedestal Credenza, file/file						
	72"W x 24"D x 29½"H, Right (shown)	3½"	H105903R	226	34.8	\$1210	\$1265
	72"W x 24"D x 29½"H, Left	3½"	H105904L	226	34.8	\$1210	\$1265
	NOTES: Drawers lock. One cord pass-through grommet in top center of modesty panel to reach wall electrical outlets. Not designed for use with 22¾"D modular or mobile pedestals. Modesty/back panel is inset 3½". See pages 269-270 for optional Stack-on Storage.						
	Low Credenza						
	72"W x 20"D x 21½"H, Drawers Right, Bookcase Left		H105975R	219	23.5	\$1324	\$1384
	72"W x 20"D x 21½"H, Drawers Left, Bookcase Right		H105976L	219	23.5	\$1324	\$1384
	60"W x 20"D x 21½"H, Drawers Right, Bookcase Left		H105973R	187	19.7	\$1219	\$1274
	60"W x 20"D x 21½"H, Drawers Left, Bookcase Right		H105974L	187	19.7	\$1219	\$1274
	NOTES: Combines with overlapping, 29½"H worksurfaces to create a multi-level workstation for a modern aesthetic. For use in open plan spaces or private offices. Two locking drawers (1 box and 1 file) and open shelving. File drawers include integrated hangrails for letter- or legal-sized folders. Bookcase has one adjustable shelf; adjusts in 1¼" increments with a range of 6". Overlapping surfaces can be supported by a 28½"H H-leg or O-leg, or 7"H O-leg, or by 7"H laminate end panel. On 60"W models, grain on back panel runs vertical for all woodgrain laminates. On 72", grain on back panel runs vertical for L1 woodgrains except for Florence and Kingswood Walnuts and horizontal on L2 laminates and Florence and Kingswood Walnuts. Optional seat cushions HLSL2036CH2 for 72"W and HLSL2030CH2 for 60"W.						

NOTES:

- Factory-configured desks, credenzas and returns ship fully assembled for ease and speed of installation.
- Formal, full-length modesty panels.
- Tops are easy-care, scratch-, spill- and stain-resistant laminate over 1½" solid core high-performance particleboard.
- 3" round cord management grommets, for routing and hiding wires and cables, are located in the tops of desks, returns, bridges, and corner units. Grommet cutout accepts optional Power Hub (model HGRMTAC) or Power/USB Hub (model HGRMTUSB2) — see page 287.
- Drawers operate on full extension, ball-bearing suspensions to ensure smooth, quiet, long-lasting operation.
- All drawers are five-sided construction for added strength and easy alignment or replacement of drawer fronts.
- File drawer design includes integrated hangrails for side-to-side letter or legal filing; and front-to-back for letter filing.
- For field installable decorative handle options, see page 285.
- 10500 Series™ 18¾"D modular and mobile pedestals can be positioned under credenza with kneespace and single pedestal credenza models.

① Keyed alike cores must be ordered separately — see model HF23B on page 853 — makes re-keying quick and easy.

HOW TO SPECIFY

Select Model Number	Select Laminate Top and Chassis Color
	See pages 236-237
	Kickplates will match chassis color
H 1 0 5 9 0 5 R .	N N

10500 SERIES™

Laminate Wood Desks — Full Pedestals

OPEN MARKET

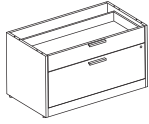

Icon Legend on page 19

**DESCRIPTION****2-Drawer Credenza, No Top**

36"W x 24"D x 19⁷/₈"H
 36"W x 20"D x 19⁷/₈"H
 30"W x 24"D x 19⁷/₈"H
 30"W x 20"D x 19⁷/₈"H

MODEL

H105LC3624BF
H105LC3620BF
H105LC3024BF
H105LC3020BF

SHIP WEIGHT

105.5
 97.9
 92.3
 85.4

CUBE

13.9
 11.7
 11.7
 9.9

L1 LIST

\$525
\$525
\$556
\$505

L2 UPCHARGES

CHASSIS	FRONTS
\$35	\$20
\$30	\$20
\$30	\$15
\$25	\$15

NOTES: Use in conjunction with Modular Credenza tops on page 262B.

🔑 Keyed alike cores must be ordered separately — see model HF23B on page 853 — makes re-keying quick and easy.

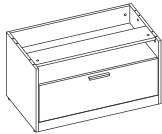
**Open/Lateral Credenza, No Top**

36"W x 24"D x 19⁷/₈"H
 36"W x 20"D x 19⁷/₈"H
 30"W x 24"D x 19⁷/₈"H
 30"W x 20"D x 19⁷/₈"H

H105LC3624SF
H105LC3620SF
H105LC3024SF
H105LC3020SF

117.2
 106.1
 101.7
 91.8

13.9
 11.7
 11.7
 9.9

\$505
\$505
\$490
\$490

CHASSIS	FRONTS
\$35	\$20
\$30	\$20
\$30	\$15
\$25	\$15

NOTES: Use in conjunction with Modular Credenza tops on page 262B. Drawer is non-locking.

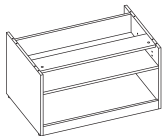
**DESCRIPTION****Open HAT Credenza, No Top**

36"W x 24"D x 19⁷/₈"H
 36"W x 20"D x 19⁷/₈"H
 30"W x 24"D x 19⁷/₈"H
 30"W x 20"D x 19⁷/₈"H

MODEL

H105LCHAT3624S
H105LCHAT3620S
H105LCHAT3024S
H105LCHAT3020S

SHIP WEIGHT

82.3
 71.2
 72.2
 62.3

CUBE

13.9
 11.7
 11.7
 9.9

LIST PRICE BY LAMINATE GRADE**L1**

\$240
\$240
\$220
\$220

L2

\$275
\$270
\$250
\$245

NOTES: False back allows HAT base leg to be concealed. Use in conjunction with Modular Credenza tops with HAT cutout on page 262B.

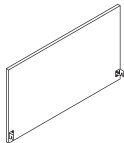
**Back for Open Storage Cabinet**

36"W x 19⁷/₈"H
 30"W x 19⁷/₈"H

H105LCHAT3620B
H105LCHAT3020B

25.0
 25.0

2.1
 1.8

\$220
\$200

\$235
\$215

NOTES: Optional model to conceal HAT base leg when used in open office settings. Use with Open HAT Credenzas, No Top when the back of the unit will be visible in an open plan office.

NOTES:

- Units can be combined to create 60"W, 66"W, and 72"W low credenzas utilizing Modular Credenzas.
- Units have unfinished tops.
- File drawers include integrated hangrails for letter- or legal-sized folders.
- Open Credenzas have one adjustable shelf; adjusts 1¹/₄" increments with a range of 6".
- Overlapping surfaces can be supported by a 28¹/₂"H or 7"H O-leg or by 7"H laminate end panel.

HOW TO SPECIFY

Select Model Number H 1 0 5 L C 3 6 2 0 B F .	Select Chassis Laminate See page 236 Kickplates will match chassis color L F W 1 .	Select Door Front Laminate See page 236 L F W 1 .	Select Pull and Color L Linear P Black L P .	Select Lock Option Only available on 2-Drawer Credenzas L Lock X Omit Lock (deduct \$20) L
--	---	---	---	--

Select Model Number H 1 0 5 L C H A T 3 6 2 0 B .	Select Chassis Laminate See page 236 Kickplates will match chassis color L F W 1
--	---

10500 SERIES™

Laminate Wood Desks — Full Pedestals

OPEN MARKET

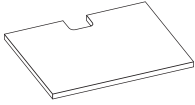
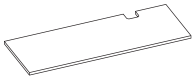
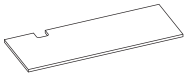
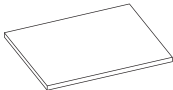

Icon Legend on page 19

DESCRIPTION	MODEL	SHIP WEIGHT	CUBE	LIST PRICE BY LAMINATE GRADE	
				L1	L2
Modular Credenza Tops, Height Adjustable Base					
 30"W x 24"D, Non-handed	H105CTHAT3620	23.5	2.3	\$395	\$410
30"W x 20"D, Non-handed	H105CTHAT3020	19.6	1.9	\$395	\$410
 72"W x 24"D, Right	H105CTHAT7224R	72.3	5.0	\$802	\$822
72"W x 20"D, Right	H105CTHAT7220R	72.3	4.2	\$802	\$822
66"W x 24"D, Right	H105CTHAT6624R	66.3	4.6	\$744	\$764
66"W x 20"D, Right	H105CTHAT6620R	60.3	3.9	\$744	\$764
60"W x 24"D, Right	H105CTHAT6024R	60.3	4.2	\$683	\$703
60"W x 20"D, Right	H105CTHAT6020R	66.3	3.6	\$683	\$703
36"W x 24"D, Right	H105CTHAT3624R	36.1	2.6	\$495	\$510
36"W x 20"D, Right	H105CTHAT3620R	36.1	2.3	\$495	\$510
 72"W x 24"D, Left	H105CTHAT7224L	72.3	5.0	\$802	\$822
72"W x 20"D, Left	H105CTHAT7220L	72.3	4.2	\$802	\$822
66"W x 24"D, Left	H105CTHAT6624L	66.3	4.6	\$744	\$764
66"W x 20"D, Left	H105CTHAT6620L	66.3	3.9	\$744	\$764
60"W x 24"D, Left	H105CTHAT6024L	60.3	4.2	\$683	\$703
60"W x 20"D, Left	H105CTHAT6020L	60.3	3.6	\$683	\$703
36"W x 24"D, Left	H105CTHAT3624L	36.1	2.6	\$495	\$510
36"W x 20"D, Left	H105CTHAT3020L	36.1	2.3	\$495	\$510
Modular Credenza Tops					
 30"W x 20"D	H105CT3020	19.6	1.9	\$395	\$410
36"W x 20"D	H105CT3620	36.1	2.3	\$495	\$510
30"W x 24"D	H105CT3024	23.5	2.3	\$395	\$410
36"W x 24"D	H105CT3624	36.1	2.6	\$495	\$510

NOTES:

- Easy care, scratch-, spill- and stain-resistant laminate over 1/8" solid core high-performance particleboard.
- Grain direction on all worksurfaces runs horizontal.
- Tops are intended to be used with modular low credenzas on page 262A.
- Tops come with hardware to attach to low credenzas.
- Tops have a right or left notch to accommodate HON's Height Adjustable Base legs.

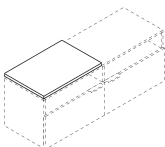
DESCRIPTION	MODEL	SHIP WEIGHT	CUBE	LIST PRICE BY FABRIC GRADE					
				1	2	3	4	5	6
Fabric Credenza Tops									
 36"W x 24"D x 1"H for 36"W Credenzas	HLAMSEAT3624	12	2.6	\$435	\$473	\$511	\$549	\$587	\$625
30"W x 24"D x 1"H for 36"W Credenzas	HLAMSEAT3024	10	2.3	\$405	\$441	\$477	\$513	\$549	\$585
36"W x 20"D x 1"H for 72"W Credenzas	HLSL2036CH2	11	2.2	\$402	\$440	\$478	\$517	\$566	\$616
36"W x 20"D x 1"H for 60"W Credenzas	HLSL2030CH2	9	1.9	\$372	\$408	\$444	\$480	\$526	\$573
NOTES: See pages 22-24 for available fabrics.									
COM: .75									
SPECIFYING EXAMPLE: HLAMSEAT3624.APN23									

HOW TO SPECIFY

Select Model Number

H105CTHAT3620.

Select Laminate and Edge Color

See page 236

LFW1FW



10500 SERIES™

Laminate Wood Desks — 3/4 Pedestals

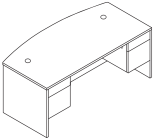
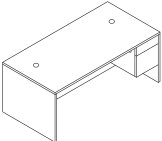
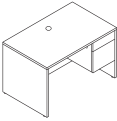
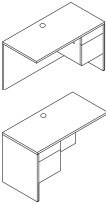
	DESCRIPTION	FULL WIDTH OVERHANG	MODEL	SHIP WEIGHT	CUBE	LIST PRICE BY LAMINATE GRADE	
						L1	L2
	Double Pedestal Desk						
	72"W x 36"D x 29½"H, Bow Top, 2-2	10½"	H10595	300	52.9	\$1560	\$1640
	72"W x 36"D x 29½"H, Rectangle Top, 2-2	10½"	H10593	320	52.9	\$1391	\$1466
	66"W x 30"D x 29½"H, Rectangle Top, 2-2	4½"	H10571	286	40.9	\$1273	\$1338
	60"W x 30"D x 29½"H, Rectangle Top, 2-2	4½"	H10573	271	37.4	\$1172	\$1232
NOTES: All drawers lock. Two cord grommets in top for routing and hiding wires and cables. Bow top models measure 36"D at crest and 30"D along the end panels. See page 288 for optional center drawers.							
	Single Pedestal Desk						
	72"W x 36"D x 29½"H, Bow Top, Right	10½"	H10587R	238	52.9	\$1347	\$1417
	72"W x 36"D x 29½"H, Rectangle Top, Right	10½"	H10585R	279	52.9	\$1182	\$1247
	66"W x 30"D x 29½"H, Rectangle Top, Right	4½"	H10583R	229	41.0	\$1039	\$1094
	72"W x 36"D x 29½"H, Bow Top, Left	10½"	H10588L	238	52.9	\$1347	\$1417
	72"W x 36"D x 29½"H, Rectangle Top, Left	10½"	H10586L	279	52.9	\$1182	\$1247
66"W x 30"D x 29½"H, Rectangle Top, Left	4½"	H10584L	229	41.0	\$1039	\$1094	
NOTES: Box/file drawers. Drawers lock. Two cord grommets in top for routing and hiding wires and cables. Bow top models measure 36"D at crest and 30"D along the end panels. See page 288 for optional center drawers.							
	Small Office Desk						
	48"W x 30"D x 29½"H, 3/4 Pedestal, Right box/file	4½"	H105885R	168	30.5	\$923	\$963
NOTES: Small footprint makes this desk ideal for limited space. Drawers lock. One cord grommet in top for routing and hiding wires and cables. 3/4 height modesty panel facilitates reaching wall electrical outlets. Optional stack-on storage model H105323 maximizes storage space; see page 269.							
	Return, box/file						
	48"W x 24"D x 29½"H, Right		H10515R	147	25.6	\$837	\$877
	42"W x 24"D x 29½"H, Right		H10511R	138	20.5	\$819	\$859
	48"W x 24"D x 29½"H, Left		H10516L	147	25.6	\$837	\$877
	42"W x 24"D x 29½"H, Left		H10512L	138	20.5	\$819	\$859
NOTES: Return is for use with single pedestal desks, desk shells, peninsulas or corner units. One worksurface grommet and one cord pass-through grommet in top center of modesty panel to reach wall electrical outlets. Drawers lock. See pages 269-270 for optional stack-on storage.							
! Not designed to be used freestanding. Will not attach to Corner Units manufactured prior to 5/24/99.							

NOTES:

- For components that can be shared with 10500 Series™, see pages 265-288.
- Tops and end panels are abrasion- and stain-resistant laminate over durable 1½" solid core high-performance particleboard; resists warping.
- Formal, full height modesty panels.
- 3/4 pedestal design increases budget flexibility.
- 3" round cord management grommets, for routing and hiding wires and cables, are located in the tops of desks, returns, bridges, and corner units. Grommet cutout accepts optional Power Hub (model HGRMTAC) or Power/USB Hub (model HGRMTUSB2) — see page 287.
- All drawers are 5-sided construction, which allows easy drawer alignment or replacement of drawer fronts.
- Drawers operate on full extension, ball-bearing suspensions to ensure smooth, quiet, long-lasting operation.
- File drawer design includes integrated hangrails for side-to-side letter or legal filing; and front-to-back for letter filing.
- For field installable decorative handle options, see page 285.
- Desk, credenza, and return models ship assembled.
- See stack-on storage and stack-on PC organizer options on pages 268-270.
- Use with Above Worksurface Privacy Screens. See page 257.
- Mobile table quickly provides additional worksurface space, see page 266.

HOW TO SPECIFY

Select Model Number	Select Laminate Top and Chassis Color
See pages 236-237	See pages 236-237
H 1 0 5 9 5 .	N N

10500 SERIES™

Laminate Wood Desks — 3/4 Pedestals

GSA SIN 33721

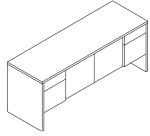

Icon Legend on page 19

**DESCRIPTION**

Credenza with Doors
72"W x 24"D x 29½"H

**FULL WIDTH
OVERHANG**

3½"

MODEL**H10544**

**SHIP
WEIGHT**

278

CUBE

36.0

LIST PRICE BY LAMINATE GRADE**L1****\$1512****L2****\$1577**

NOTES: All drawers lock. Doors are non-locking. Includes a fixed shelf located at the bottom of the center storage area. No intermittent shelf. See pages 269-270 for optional stack-on storage.

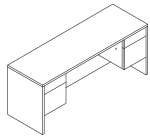
**Credenza with Kneespace — box/file**

72"W x 24"D x 29½"H
66"W x 24"D x 29½"H
60"W x 24"D x 29½"H

3½"

H10543

243

36.3

\$1240**\$1300**

3½"

H10566

234

33.4

\$1228**\$1288**

3½"

H10565

229

28.8

\$1172**\$1227**

NOTES: All drawers lock. One cord pass-through grommet in top center of modesty panel to reach wall electrical outlets.

⚠ Not designed to be used with 22¾"D modular or mobile pedestals. Modesty/back panel is inset 3½".

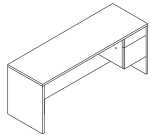
**Single Pedestal Credenza — box/file**

72"W x 24"D x 29½"H, Right (shown)
72"W x 24"D x 29½"H, Left

3½"

H10545R

212

36.0

\$1023**\$1078**

3½"

H10546L

212

36.0

\$1023**\$1078**

NOTES: Drawers lock. One cord pass-through grommet in top center of modesty panel to reach wall electrical outlets. See page 269 for optional stack-on storage.

⚠ Not designed to be used with 22¾"D modular or mobile pedestals. Modesty/back panel is inset 3½".

NOTES:

- For components that can be shared with 10500 Series™, see pages 265-288.
- Tops and end panels are abrasion- and stain-resistant laminate over durable 1/8" solid core high-performance particleboard; resists warping.
- Formal, full height modesty panels.
- 3/4 pedestal design increases budget flexibility.
- 3" round cord management grommets, for routing and hiding wires and cables, are located in the tops of desks, returns, bridges, and corner units. Accepts optional Power Hub Grommet model HGRMTAC — page 287.
- All drawers are 5-sided construction, which allows easy drawer alignment or replacement of drawer fronts.
- Drawers operate on full extension, ball-bearing suspensions to ensure smooth, quiet, long-lasting operation.
- File drawer design includes integrated hangrails for side-to-side letter or legal filing; and front-to-back for letter filing.
- For field installable decorative handle options, see page 285.
- Desk, credenza, and return models ship assembled.
- See stack-on storage and stack-on PC organizer options on pages 268-270.
- Use with Above Worksurface Privacy Screens. See page 257.
- Mobile table quickly provides additional worksurface space, see page 266.

HOW TO SPECIFY

Select
Model Number

H 1 0 5 4 4 .

Select
Laminate Top and Chassis Color

See pages 236-237

N N

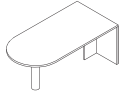

DESCRIPTION

Peninsula w/End Panel

72"W x 36"D x 29½"H
 72"W x 30"D x 29½"H
 66"W x 30"D x 29½"H
 60"W x 30"D x 29½"H

MODEL	SHIP WEIGHT	CUBE	LIST PRICE BY LAMINATE GRADE	
			L1	L2
H10521	150	15.1	\$877	\$922
H105209	130	12.8	\$819	\$864
H10522	125	11.8	\$808	\$853
H10523	100	10.7	\$757	\$802

NOTES: Use for "U" or "L" configuration. 60"W size ideal for smaller spaces. Cord routing notch in brace panel. Accepts field installable modesty panel model H10528. Accepts center drawer model H1526 and H1522. Model H1522 can be used in conjunction with the laminate modesty panel model H10528. Round support column is black.

ⓘ Not designed to be used freestanding.

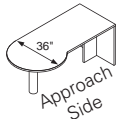

72"W x 30/36"D x 29½"H, P-shaped Right (shown)
 72"W x 36/30"D x 29½"H, P-shaped Left

H10525R	142	13.4	\$1026	\$1071
H10526L	142	13.4	\$1026	\$1071

NOTES: Use for "U" or "L" configuration. Cord routing notch in brace panel. Accept field installable modesty panel model H10528 (see page 266). See page 288 for optional center drawers. Round support column is black.

ⓘ Not designed to be used freestanding.

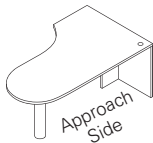

Right-hand model H105201R shown

Jetty Peninsula w/End Panel

72"W x 30/42"D x 29½"H, Right (shown)
 72"W x 42/30"D x 29½"H, Left

H105201R	156	16.9	\$1138	\$1193
H105202L	156	16.9	\$1138	\$1193

NOTES: For use in "U" or "L" configuration. Designed and sized to efficiently serve as both a computing and conferencing space. One cord management grommet in the top; cord routing notch in brace panel. Round support column is black.

ⓘ Not designed to be used freestanding. Jetty units manufactured on or after 10/24/2005 accept field installable modesty panel H10528 (see page 266).

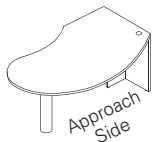
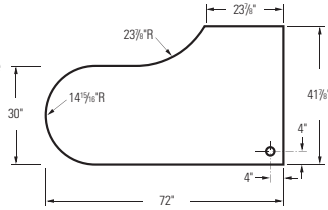

Right-hand model H105203R shown

Boomerang Peninsula w/End Panel

72"W x 30/42"D x 29½"H, Right (shown)
 72"W x 42/30"D x 29½"H, Left

H105203R	152	16.9	\$1138	\$1193
H105204L	152	16.9	\$1138	\$1193

NOTES: For use in "U" or "L" configuration. Designed and sized to efficiently serve as both a computing and conferencing space. One cord management grommet in the top; cord routing notch in brace panel. Round support column is black.

ⓘ Not designed to be used freestanding. Accept field installable modesty panel H10528 (see page 266).

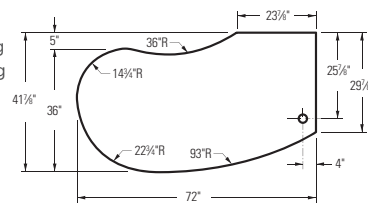

NOTES:

- Shared components shown on this page can be used with modular components shown on pages 244-260, full pedestal models shown on pages 261-262 and 3/4 pedestal models shown on pages 263-264.
- Jetty, boomerang and rudder peninsulas are designed and sized to efficiently serve as both a computing and conferencing space.
- Peninsulas ship complete with end panel and black 4½" diameter support column. For a silver support column option, please see model HPC191X on page 251 (ordered separately).
- Mobile pedestals shown on page 276 work well in a variety of configurations.
- Adjustable hex leveling glides allow floor-standing furniture to be easily leveled without lifting the unit; glides have ¾" adjustable range.
- See pages 265-288 for shared components.

HOW TO SPECIFY

<p>Select Model Number</p> <p>H 1 0 5 2 5 R .</p>	<p>Select Laminate Top and Chassis Color</p> <p>See pages 236-237</p> <p>N N</p>
---	--

10500 SERIES™

Shared Components & Accessories

GSA SIN 33721



Icon Legend on page 19

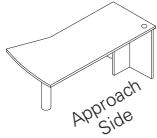

Model H105205R shown



DESCRIPTION	MODEL	SHIP WEIGHT	CUBE	LIST PRICE BY LAMINATE GRADE	
				L1	L2
Rudder Peninsula with End Panel 72"W x 30/38"D x 29½"H, Right (shown)	H105205R	142	15.8	\$1113	\$1158
72"W x 30/38"D x 29½"H, Left	H105206L	142	15.8	\$1113	\$1158

NOTES: Use for "U" or "L" configuration. One cord management grommet in top; cord routing notch in brace panel. 30"D along end panel. Round support column is black.

ⓘ Not designed to be used freestanding.



Field Installable Laminate Modesty Panel for Peninsulas

50¼"W x ¾"Thick x 18"H

MODEL	SHIP WEIGHT	CUBE	L1	L2
H10528	25	1.3	\$188	\$198

NOTES: Center drawer model H1522 can be used in conjunction with the laminate modesty panel. Laminate modesty panel has a cord pass-through notch in top corner.

ⓘ Not compatible with Peninsula models H10525R, H10526L, H10621, H10721, H10722 manufactured prior to 12/1/2001 or jetty models H105201R and H105202L manufactured prior to 10/24/2005.

SPECIFYING EXAMPLE: H10528.N



Field Installable Modesty Panel, Frosted with Silver Frame

50¼"W x ¾"Thick x 18"H — for use on 72"W peninsulas

MODEL	SHIP WEIGHT	CUBE	LIST PRICE
HPC180G	33 Ⓞ	1.5	\$694

ⓘ Center drawers not designed to be used with the frosted/silver modesty panel. Cord pass-through notch is not available on the Frosted/Silver model HPC180G. Notch is on laminate model H10528 only.

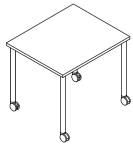

DESCRIPTION	MODEL	SHIP WEIGHT	CUBE	LIST PRICE BY LAMINATE GRADE	
				L1	L2
Mobile Table 36"W x 30"D x 29½"H	H105T3036C	56	11.0	\$640	\$655
30"W x 24"D x 29½"H	H105T2430C	42	7.1	\$573	\$585

NOTES: Rectangle-shaped top. Versatile design quickly provides additional worksurface space; ideal for work-in-process, meetings, and special projects. Choose from two sizes to align with either 30" and 36"D or 24" and 30"D worksurfaces. Roll easily on 4 casters; 2 locking, 2 non-locking. Top and legs ship together in one carton. Simple assembly. Easy-care, scratch-, spill- and stain-resistant laminate over 1½" solid core high-performance particleboard.

Specify: Model.Worksurface Laminate.Edge Color.Base Paint Color

SPECIFYING EXAMPLE: H105T3036C.N.N.S

NOTES:

Panels

- Shared components shown on this page can be used with modular components shown on pages 244-260, full pedestal models shown on pages 261-262 and 3/4 pedestal models shown on pages 263-264.
- Jetty, boomerang and rudder peninsulas are designed and sized to efficiently serve as both a computing and conferencing space.
- Peninsulas ship complete with end panel and black 4½" diameter support column. For a silver support column option, please see model HPC191X on page 251 (ordered separately).
- Mobile pedestals shown on page 276 work well in a variety of configurations.
- Adjustable hex leveling glides allow floor-standing furniture to be easily leveled without lifting the unit; glides have ¾" adjustable range.
- See pages 265-288 for shared components.

HOW TO SPECIFY

Select Model Number <input type="text" value="H105205R"/>	Select Laminate Top and Chassis Color See pages 236-237 <input type="text" value="NN"/>		
Select Model Number <input type="text" value="H105T3036C"/>	Select Worksurface Laminate See pages 236-237 <input type="text" value="N"/>	Select Edge Color See pages 236-237 <input type="text" value="N"/>	Select Base Paint Color See page 236 <input type="text" value="S"/>



10500 SERIES™

Shared Components & Accessories

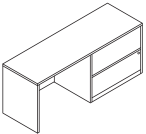
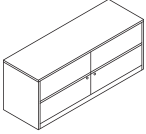
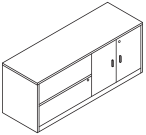
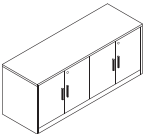
	DESCRIPTION	MODEL	SHIP WEIGHT	CUBE	LIST PRICE BY LAMINATE GRADE	
					L1	L2
	Bridge (Single Ped. Desk, Desk Shell, or Peninsula, to Corner Unit, Single Ped. Credenza or Credenza Shell) 47"W x 24"D x 29½"H (Clear inside depth = 21⅞"D)	H10570	76	2.8	\$364	\$394
	42"W x 24"D x 29½"H (Clear inside depth = 21⅞"D)	H10560	72	2.6	\$350	\$380
	Bridge (for use with Corner or Extended Corner Units or Jetty or Boomerang Peninsulas) 36"W x 24"D x 29½"H (Clear inside depth = 21⅞"D)	H105599	61	2.6	\$350	\$380
	Bridge (for use with Corner or Extended Corner Units) 30"W x 24"D x 29½"H (Clear inside depth = 21⅞"D)	H105598	50	1.9	\$350	\$380
	NOTES: One cord grommet in top; one pass-through grommet in top center of modesty panel. Grommet can be replaced with optional Power Hub or Power/USB Hub for easy plug-and-play (see page 287). Kneespace of desk limited to 24¾"W if bridge is used with 66"W single pedestal desk.					
	ⓘ Not designed to attach to corner units manufactured prior to 5/24/99.					
	Bridge (Single Ped. Desk, Desk Shell, or Peninsula to Single Ped. Credenza or Credenza Shell) 47"W x 20"D x 29½"H (Clear inside depth = 17⅞"D)	H105699	61	2.8	\$350	\$380
	42"W x 20"D x 29½"H (Clear inside depth = 17⅞"D)	H105698	54	2.6	\$325	\$355
	NOTES: One cord grommet in top; one pass-through grommet in top center of modesty panel.					
	ⓘ Models H105699 and H105698 cannot be connected to corner or extended corner units or to the jetty or boomerang peninsulas, due to the 20"D "hook-up".					
	Credenza with 36" Lateral (with core removable lock) 72"W x 24"D x 29½"H, Right (shown)	H10547R	248	35.6	\$1400	\$1460
	72"W x 24"D x 29½"H, Left	H10548L	248	35.6	\$1400	\$1460
	NOTES: One cord pass-through grommet in top center of modesty panel. Includes hangrails. Mechanical interlock inhibits the extension of more than one drawer at a time. Accepts optional stack-on storage model H10534 (page 269) or PC Organizer model H105388 (page 268).					
	ⓘ Not designed to be used with 10500 Series™ 22¾"D modular or mobile pedestals. Modesty/back panel is inset 3½".					
	Credenza with two Lateral Files (4 locking drawers. Each core removable lock secures 2 drawers) 72"W x 24"D x 29½"H	H105491	314	34.7	\$2021	\$2096
	NOTES: Includes hangrails; mechanical interlock inhibits the extension of more than one drawer at a time. If side-by-side drawers are opened or closed simultaneously, one drawer may interfere with the other. Two locks (keyed alike). Accepts optional stack-on storage model H10534 (page 269) or PC Organizer model H105388 (page 268).					
	Credenza with Lateral File, left and Storage Cabinet, right (with core removable locks) 72"W x 24"D x 29½"H	H105492	307	34.7	\$1768	\$1843
	NOTES: Includes hangrails; mechanical interlock inhibits the extension of more than one drawer at a time. Storage cabinet locks and includes one adjustable interior shelf. Shelf adjusts in 1¼" increments with a total range of 5"H. Two locks (keyed alike). Accepts optional stack-on storage model H10534 (page 269) or PC Organizer model H105388 (page 268).					
	Credenza with Two Storage Cabinets (with core removable locks) 72"W x 24"D x 29½"H	H105493	302	34.8	\$1648	\$1723
	NOTES: Each storage cabinet has one interior shelf which adjusts in 1¼" increments over a total range of 5". Each cabinet locks independently; locks are keyed alike. Accepts optional stack-on storage model H10534 (page 269) or PC Organizer model H105388 (page 268).					

NOTES:

- Shared components shown on this page can be used with modular components shown on pages 244-260, full pedestal models shown on pages 261-262, and 3/4 pedestal models shown on pages 263-264.
- Locking units equipped with interchangeable core removable locks.
- File drawers accept hanging folders in letter or legal size.
- Mobile pedestals shown on page 276 work well in a variety of configurations.
- Work Organizer models accept 3-ring binders and organizer model HTC0L52. See page 280.
- See stack-on storage and organizer options for desks, credenzas and returns, pages 268-270.
- See pages 265-288 for shared components.

ⓘ Keyed alike cores must be ordered separately — see model HF23B on page 853.

HOW TO SPECIFY

Select Model Number <input type="text" value="H10570"/>	Select Laminate Top and Chassis Color See pages 236-237 <input type="text" value="NN"/>
---	--

10500 SERIES™

Shared Components & Accessories

GSA SIN 33721

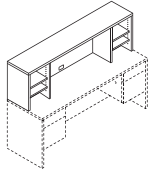

Icon Legend on page 19

**DESCRIPTION****Stack-on PC Organizer**72"W x 14⁵/₈"D x 22"H (for 72"W desks, credenzas and shells)60"W x 14⁵/₈"D x 22"H (for 60"W desks, credenzas and shells)

MODEL	SHIP WEIGHT	CUBE	LIST PRICE BY LAMINATE GRADE	
			L1	L2

H105388

124

5.0

\$814**\$849****H105386**

111

4.3

\$755**\$790**

NOTES: Features two adjustable paper management shelves both left and right; shelves are adjustable in 1/4" increments. Shelves keep papers, files, and books within easy reach from a seated position. One cord management grommet located in the bottom center of the back panel. Design allows 20³/₄" of vertical clearance for computer equipment.

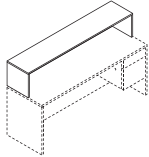
**Work Organizer (shell only)**72"W x 14⁵/₈"D x 14¹/₈"H (for 72"W unit)66"W x 14⁵/₈"D x 14¹/₈"H (for 66"W unit)**H10537**

73

2.9

\$421**\$451****H10536**

68

2.7

\$400**\$430**

NOTES: Space below counter accepts 3-ring binders and organizer model HTC0L52. See page 280.

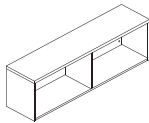
**Open Shared Storage**60"W x 14⁵/₈"D x 16⁷/₈"H48"W x 14⁵/₈"D x 16⁷/₈"H**H105368**

81

14.2

\$769**\$799****H105367**

68

11.5

\$749**\$774**

NOTES: Attaches to laminate end panels with horizontally mounted interlocking brackets. Mounting applications include: 60"W — two 30"D desks/desk shells, 60"W — two 48"W (minimum) x 30"D rectangle worksurfaces supported by 28¹/₂"H L-shaped end panels, 48"W — two 24"D credenzas/credenza shells, 48"W — two 24"D returns/return shells, 48"W — two 60"W (minimum) x 24"D rectangle worksurfaces supported by 28¹/₂"H L-shaped end panels. Can also be positioned on the worksurface; double-sided tape included. Grain direction is vertical on top, back, end panels, and shelf. Ships fully assembled. Not designed for attachment to a worksurface supported by H-legs or O-legs. Inside dimensions for 60"W: each compartment 28³/₄"W x 13¹/₂"D x 15¹/₂"H. Inside dimensions for 48"W: each compartment 22³/₄"W x 13¹/₂"D x 15¹/₂"H.

NOTES:

- Shared components shown on this page can be used with modular components shown on pages 244-260, full pedestal models shown on pages 261-262, and 3/4 pedestal models shown on pages 263-264.
- Mobile pedestals shown on page 276 work well in a variety of configurations.
- See stack-on storage and organizer options for desks, credenzas and returns, pages 268-270.
- See pages 265-288 for shared components.
- Locking units equipped with interchangeable core removable locks.

ⓘ Keyed alike cores must be ordered separately — see model HF23B on page 853.

HOW TO SPECIFY

Select Model Number H 1 0 5 3 8 8 .	Select Laminate Top and Chassis Color See pages 236-237 N N
---	--

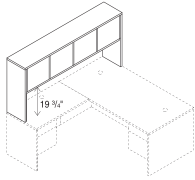
**DESCRIPTION**

Stack-on Storage for an "L" Workstation
78"W x 14⁵/₈"D x 37¹/₈"H

MODEL	SHIP WEIGHT	CUBE	LIST PRICE BY LAMINATE GRADE	
			L1	L2

H105327	198	17.6	\$1144	\$1209
----------------	-----	------	---------------	---------------

Stack-on Storage for an "L" Workstation, Locking 
78"W x 14⁵/₈"D x 37¹/₈"H

H105327K	198	17.6	\$1224	\$1289
-----------------	-----	------	---------------	---------------

NOTES: Spans the total depth dimension of configurations comprised of: 48"W return or return shell attached to a 30"D single pedestal desk, desk shell or peninsula (78"D); 42"W return or return shell attached to a 36"D single pedestal desk or desk shell with a rectangle top, or to a peninsula (78"D). 42"W return or return shell attached to a 36" corner unit (78"D); or 42"W curved return attached to 36" curved corner unit (78"D). Use back enclosure model H105857 and model H90057. Use task light models HH870960 or HH870960CH (see page 545). For vertical paper manager model HLVP1, see page 282.

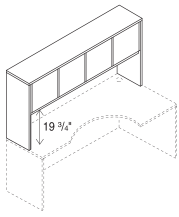
**Stack-on Storage**

72"W x 14⁵/₈"D x 37¹/₈"H, 4 doors
(Use Task Light HH870960, see page 274)
66"W x 14⁵/₈"D x 37¹/₈"H, 4 doors
(Use Task Light HH870960, see page 274)
60"W x 14⁵/₈"D x 37¹/₈"H, 4 doors
(Use Task Light HH870960, see page 274)
48"W x 14⁵/₈"D x 37¹/₈"H, 3 doors
(Use Task Light HH870942, see page 274)
42"W x 14⁵/₈"D x 37¹/₈"H, 2 doors
(Use Task Light HH870942, see page 274)
36"W x 14⁵/₈"D x 37¹/₈"H, 2 doors
(Use Task Light HH870930, see page 274)

H10534	185	17.1	\$1011	\$1051
H10533	175	15.3	\$983	\$1038
H105324	164	14.0	\$943	\$998
H105323	141	11.3	\$850	\$895
H105322	135	4.0	\$696	\$741
H105321	102	3.5	\$657	\$687

Stack-on Storage, Locking 

72"W x 14⁵/₈"D x 37¹/₈"H, 4 doors
(Use Task Light HH870960, see page 274)
66"W x 14⁵/₈"D x 37¹/₈"H, 4 doors
(Use Task Light HH870960, see page 274)
60"W x 14⁵/₈"D x 37¹/₈"H, 4 doors
(Use Task Light HH870960, see page 274)
48"W x 14⁵/₈"D x 37¹/₈"H, 3 doors
(Use Task Light HH870942, see page 274)
42"W x 14⁵/₈"D x 37¹/₈"H, 2 doors
(Use Task Light HH870942, see page 274)
36"W x 14⁵/₈"D x 37¹/₈"H, 2 doors
(Use Task Light HH870930, see page 274)

H10534K	185	17.1	\$1091	\$1146
H10533K	175	15.3	\$1063	\$1118
H105324K	164	14.0	\$1023	\$1078
H105323K	141	11.3	\$890	\$935
H105322K	135	4.0	\$736	\$781
H105321K	102	3.5	\$697	\$737

NOTES: For use on respective desk, credenza or return widths. Model H10534 can be used for "L" configuration comprised of 30"D desk, desk shell or peninsula and 42"W return or return shell; or a 36"D desk, desk shell, peninsula, or corner unit and 36"W return shell. Model **H105323K** has one lock which secures two of the three doors. See vertical paper manager model HLVP1 on page 282.

NOTES:

- Shared components shown on this page can be used with modular components shown on pages 244-260, full pedestal models shown on pages 261-262, and 3/4 pedestal models shown on pages 263-264.
- Rich woodgrain laminate and frosted doors with silver frames adds a contemporary mixed materials option to the 10500 Series™.
- Stack-on storage models are equipped with self-closing, adjustable hinged doors and valance to hide task light.
- See page 272 for stack-on storage back enclosures and , and page 274 for task lights.
- For work-in-process paper management tools, see pages 282-283.
- See pages 265-288 for shared components.
- **Removable lock core kit for locking stack-on storage is model HF27B. See page 853.**

HOW TO SPECIFY

Select
Model Number

H 1 0 5 3 2 7

Select
Laminate Top and Chassis Color

See pages 236-237

N N

10500 SERIES™

Shared Components & Accessories

GSA SIN 33721

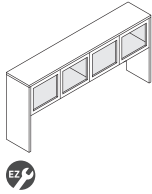

Icon Legend on page 19

**DESCRIPTION****Stack-on Storage for an "L" Workstation, Frosted Doors with Silver Frame**78"W x 14⁵/₈"D x 37¹/₈"H**MODEL****SHIP WEIGHT****CUBE****LIST PRICE BY LAMINATE GRADE****L1****L2****H105327G**

198

17.3

\$1744**\$1794**

NOTES: Spans the total depth dimension of configurations comprised of: 48"W return or return shell attached to a 30"D single pedestal desk, desk shell or peninsula (78"D); 42"W return or return shell attached to a 36"D single pedestal desk or desk shell with a rectangle top, or to a peninsula (78"D); 42"W return or return shell attached to a 36" corner unit (78"D); 42"W curved return attached to 36" curved corner unit (78"D); or 36"W return shell attached to a jetty peninsula (78"D). Use back enclosure model H105857 and model H90057. Use task light models HH870960 or HH870960CH. For vertical paper manager model HLVP1, see page 282.

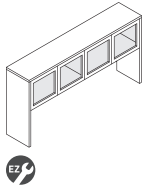
**Stack-on Storage, Frosted Doors with Silver Frame**72"W x 14⁵/₈"D x 37¹/₈"H, 4 doors

(Use Task Light HH870960, see page 274)

66"W x 14⁵/₈"D x 37¹/₈"H, 4 doors

(Use Task Light HH870960, see page 274)

60"W x 14⁵/₈"D x 37¹/₈"H, 4 doors

(Use Task Light HH870960, see page 274)

48"W x 14⁵/₈"D x 37¹/₈"H, 3 doors

(Use Task Light HH870942, see page 274)

42"W x 14⁵/₈"D x 37¹/₈"H, 2 doors

(Use Task Light HH870942, see page 274)

36"W x 14⁵/₈"D x 37¹/₈"H, 2 doors

(Use Task Light HH870930, see page 274)

H10534G

185

15.9

\$1611**\$1651****H10533G**

175

14.6

\$1583**\$1623****H105324G**

164

13.3

\$1543**\$1583****H105323G**

141

10.8

\$1300**\$1330****H105322G**

135

3.6

\$996**\$1026****H105321G**

102

3.1

\$957**\$982**

NOTES: For respective desk, credenza or return widths. Model 10534 can be used for "L" configuration comprised of a 42"W return or return shell attached to a 30"D single pedestal desk, desk shell or peninsula (72"); 36"W return shell attached to a 36"D single pedestal desk, desk shell or peninsula (72"); or 30"W return shell attached to a jetty peninsula (72"). Back enclosures, for use with back enclosures and task lights are available as options. See vertical paper manager model HLVP1 on page 282.

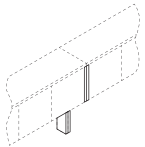
**Stack-on Storage Clearance End Panel Kit**1¹/₈"W x 4⁵/₈-14⁵/₈"D x 36"H**H105349**

29

3.4

\$360**\$375**

Two field installable end panels (1-right; 1-left) for use in ganging two 10500 or Valido® Series stack-on storage units. Narrow design replaces the full 14⁵/₈"D end panels to expand worksurface space. The narrow right end panel replaces the standard 14⁵/₈"D right end panel on one stack-on storage unit, the narrow left end panel replaces the standard 14⁵/₈"D left end panel on a separate, adjacent stack-on storage unit that is in linear alignment with the first unit. Kit includes: (2) narrow end panel supports; European-style fasteners; dowels; joint connector bolts with sleeve nuts (for ganging stack-on storage units).

NOTES: Can be used to connect up to two stack-on storage units in a line (requires 1 kit). Not available in two-tone laminate.

SPECIFYING EXAMPLE: H105349.N**NOTES:**

- Shared components shown on this page can be used with modular components shown on pages 244-260, full pedestal models shown on pages 261-262, and 3/4 pedestal models shown on pages 263-264.
- Rich woodgrain laminate and frosted doors with silver frames adds a contemporary mixed materials option to the 10500 Series™.
- Stack-on storage models are equipped with self-closing, adjustable hinged doors and valance to hide task light.
- See page 272 for stack-on storage back enclosures and , and page 274 for task lights.
- For work-in-process paper management tools, see pages 282-283.
- See pages 265-288 for shared components.
- Removable lock core kit for locking stack-on storage is model HF27B. See page 853.**

HOW TO SPECIFY

Select Model Number

H 1 0 5 3 2 7 G .

Select Laminate Top and Chassis Color

See pages 236-237

N N

10500 SERIES™

Shared Components & Accessories

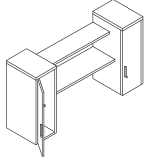
**DESCRIPTION****Stack-on Cabinets with Open Shelves, Center**Overall measures: 72"W x 20"D x 37¹/₈"HCabinet measures: 13¹/₂"W x 19⁷/₈"D x 37¹/₈"H

NOTES: Contemporary, light scale design blends open and closed storage. Features two locking cabinets bridged by two open shelves. The clearance between the worksurface and underside of the lower shelf is 18⁵/₈". Top shelf is 45"W x 11"D, bottom shelf is 45"W x 14"D; space between the shelves is 12¹/₄". Some assembly required; cabinets are fully assembled; simple shelf attachment. For two-tone color combinations, the first color designator defines the top of the storage cabinet(s), the second designator defines the color of the cabinet vertical panels and the open (exterior) shelves.

MODEL	SHIP WEIGHT	CUBE	L1 LIST	L2 UPCHARGES	
				CHASSIS	SHELF
H105319	218	20.3	\$1758	\$60	\$20

NOTES:

- Stack-on Cabinets with Open Shelves, Center is sized to fit on 72" desk, credenza, return, or desk with return worksurfaces.
- Easy-care, scratch-, spill- and stain-resistant laminate over 1/8" solid core high-performance particleboard.
- Cabinets have three shelves, two are adjustable.
- Removable lock core kit for the cabinet models above is HF23B. See page 853.
- Back of cabinet door has a convenient double coat hook; the lower peg is for jackets and lighter items, the upper peg for heavier coats and bags.
- Open shelves display books, photos, and mementos, shelves are fixed height; top shelf is 3/4" thick, lower shelf is 1/8".
- Task light can be attached to underside of the bottom shelf.

HOW TO SPECIFY

Select
Model Number

H 1 0 5 3 1 9 .

Select
Cabinet Top and Chassis Color

See pages 236-237

H H .

Select
Open Shelf Laminate

See pages 236-237

H

10500 SERIES™

Shared Components & Accessories

GSA SIN 33721



Icon Legend on page 19

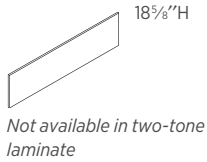

DESCRIPTION	MODEL	SHIP		LIST PRICE BY LAMINATE GRADE	
		WEIGHT	CUBE	L1	L2
Back Enclosure for Stack-on Storage					
75 $\frac{3}{4}$ "W - for 78"W model #H105327/H105327K/H105327G	H105857	39	1.4	\$259	\$269
69 $\frac{3}{4}$ "W - for 72"W model #H10534/H10534K/H10534G	H105856	33	1.3	\$237	\$247
63 $\frac{3}{4}$ "W - for 66"W model #H10533/H10533K/H10533G	H105855	31	1.3	\$221	\$231
57 $\frac{3}{4}$ "W - for 60"W model #H105324/H105324K/H105324G	H105854	29	1.3	\$211	\$221
45 $\frac{3}{4}$ "W - for 48"W model #H105323/H105323K/H105323G	H105853	23	0.9	\$211	\$221
39 $\frac{3}{4}$ "W - for 42"W model #H105322/H105322K/H105322G	H105852	21	0.9	\$201	\$211
33 $\frac{3}{4}$ "W - for 36"W model #H105321/H105321K/H105321G	H105851	18	0.9	\$190	\$200

NOTES: Non-tackable.

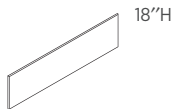

DESCRIPTION	MODEL	COM	SHIP WEIGHT	CUBE	LIST PRICE
for use with Stack-on Back Enclosures (Back Enclosures must be ordered separately.)					
75"W - for 78"W model #H105327 Hutch with #H105857 Enclosure	H90057	3.0	13	3.2	\$317
68 $\frac{3}{4}$ "W - for 72"W model #H10534 Hutch with #H105856 Enclosure	H90056	2.0	12	2.7	\$301
62 $\frac{3}{4}$ "W - for 66"W model #H10533 Hutch with #H105855 Enclosure	H90055	2.0	11	2.5	\$286
56 $\frac{3}{4}$ "W - for 60"W model #H105324 Hutch with #H105854 Enclosure	H90054	2.0	10	2.2	\$252
44 $\frac{3}{4}$ "W - for 48"W model #H105323 Hutch with #H105853 Enclosure	H90053	2.0	8	1.8	\$242
39"W - for 42"W model #H105322 Hutch with #H105852 Enclosure	H90052	2.0	7	1.6	\$223
33"W - for 36"W model #H105321 Hutch with #H105851 Enclosure	H90051	1.0	6	1.4	\$196
26 $\frac{3}{4}$ "W	H90050	1.0	5	1.2	\$196

NOTES: Specify fabric, see pages 25-26. Upcharges may apply to premium fabric grades.

ⓘ Disperse (DISP) fabric not available on sizes wider than 60". Analog (ANLG) and Exchange (EXG) not available on sizes wider than 72".

SPECIFYING EXAMPLE: H90057.APN15**NOTES:**

- When connected to the stack-on storage unit, back enclosure features full-width 1 $\frac{1}{8}$ " slot at the bottom to facilitate routing cords and reaching wall electrical outlets.
- is sized $\frac{3}{4}$ " narrower than stack-on storage back enclosure, allowing $\frac{3}{8}$ " on each side to route task light cord.
- includes adhesive tape to secure to back enclosure and hardware for wall attachment.
- See pages 265-288 for shared components.

HOW TO SPECIFY

Select Model Number <div style="border: 1px solid black; padding: 2px; display: flex; gap: 5px;"> H105857 </div>	Select Laminate See pages 236-237 <div style="border: 1px solid black; padding: 2px; display: flex; gap: 5px;"> N </div>
---	--



10500 SERIES™

Shared Components & Accessories

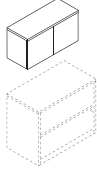

DESCRIPTION	MODEL	SHIP WEIGHT	CUBE	LIST PRICE BY LAMINATE GRADE	
				L1	L2
Wall Mounted Storage Cabinet 48"W x 14 $\frac{5}{8}$ "D x 17 $\frac{1}{2}$ "H, 3 doors (Use task light model HH870942, see page 274) 42"W x 14 $\frac{5}{8}$ "D x 17 $\frac{1}{2}$ "H, 2 doors (Use task light model HH870942, see page 274) 36"W x 14 $\frac{5}{8}$ "D x 17 $\frac{1}{2}$ "H, 2 doors (Use task light model HH870930, see page 274) 30"W x 14 $\frac{5}{8}$ "D x 17 $\frac{1}{2}$ "H, 2 doors (Use task light model HH870930, see page 274)	H105383	114	13.2	\$878	\$913
	H105382	97	11.7	\$821	\$856
	H105381	87	10.2	\$748	\$783
	H105380	73	8.7	\$697	\$732
Wall Mounted Storage Cabinet, Locking 48"W x 14 $\frac{5}{8}$ "D x 17 $\frac{1}{2}$ "H, 3 doors (Use task light model HH870942, see page 274) 42"W x 14 $\frac{5}{8}$ "D x 17 $\frac{1}{2}$ "H, 2 doors (Use task light model HH870942, see page 274) 36"W x 14 $\frac{5}{8}$ "D x 17 $\frac{1}{2}$ "H, 2 doors (Use task light model HH870930, see page 274) 30"W x 14 $\frac{5}{8}$ "D x 17 $\frac{1}{2}$ "H, 2 doors (Use task light model HH870930, see page 274)	H105383K	114	13.2	\$918	\$953
	H105382K	97	11.7	\$861	\$896
	H105381K	87	10.2	\$788	\$823
	H105380K	73	8.7	\$737	\$772

NOTES: Horizontal interlocking rails are included; due to varying types of walls, installers are responsible for selecting and supplying the appropriate fasteners. widths differ slightly from wall mounted storage cabinet widths. For applications where multiple wall mounted storage cabinets are placed side-by-side, the preferred solution may be to utilize a larger size. For wall mounted storage cabinets with frosted doors, see page 274.

SPECIFYING EXAMPLE: H105380.NN
If Specifying with Lock Option: H105380K.NN

NOTES:

- is sized $\frac{3}{4}$ " narrower than stack-on storage back enclosure, allowing $\frac{3}{8}$ " on each side to route task light cord.
- Wall attachment methodology: horizontally mounted, interlocking brackets.
- Wall mounted storage cabinet door design overlaps end panels so that when multiple units are placed side-by-side they appear as one continuous unit.
- Wall mounted storage cabinets available with laminate doors, locking laminate doors or frosted doors.
- Removable lock core kit for locking stack-on and wall mounted storage is model HF27B. See page 853.
- See pages 265-288 for shared components.

Wall mounted storage cabinet attachment requires individual cabinets be secured by a minimum of two wall mounting locations/studs.

Wall mounted storage cabinets are designed for interior and perimeter walls that are constructed with wood or metal studs.

The HON Company is not responsible for any liabilities resulting from wall mounted storage cabinets that are not properly installed.

HOW TO SPECIFY

Select
Model Number

H 1 0 5 3 8 0 K .

Select
Laminate Top and Chassis Color

See pages 236-237

N N



Icon Legend on page 29

10500 SERIES™ Shared Components & Accessories

	DESCRIPTION	MODEL	SHIP WEIGHT	CUBE	L1 LIST	L2 UPCHARGES	
						CHASSIS	FRONTS
	Wall Mounted Hutch						
	66"W x 14 5/8"D x 15"H, 4 doors	H105WMH66	120	16.1	\$1282	\$30	\$30
	48"W x 14 5/8"D x 15"H, 3 doors	H105WMH48	97	12.6	\$918	\$25	\$30
	42"W x 14 5/8"D x 15"H, 2 doors	H105WMH42	77	10.7	\$861	\$25	\$20
	36"W x 14 5/8"D x 15"H, 2 doors	H105WMH36	67	9.8	\$788	\$25	\$20
	30"W x 14 5/8"D x 15"H, 2 doors	H105WMH30	57	8.3	\$737	\$25	\$20
	Wall Mounted Cubby Hutch						
	66"W x 14 5/8"D x 20"H, 4 doors	H105WMH66C	155	19.6	\$1282	\$30	\$30
	48"W x 14 5/8"D x 20"H, 3 doors	H105WMH48C	128	15.2	\$918	\$25	\$30
	42"W x 14 5/8"D x 20"H, 2 doors	H105WMH42C	114	13.0	\$861	\$25	\$20
	36"W x 14 5/8"D x 20"H, 2 doors	H105WMH36C	89	11.8	\$788	\$25	\$20
	30"W x 14 5/8"D x 20"H, 2 doors	H105WMH30C	76	10.0	\$737	\$25	\$20
	Wall Mounted Open Hutch						
	72"W x 14 5/8"D x 15"H, 2 Doors	H105WMH72P	119	17.5	\$1400	\$35	\$35
	66"W x 14 5/8"D x 15"H, 2 Doors	H105WMH66P	111	16.1	\$1282	\$30	\$30
	60"W x 14 5/8"D x 15"H, 2 Doors	H105WMH60P	104	14.7	\$1161	\$30	\$30
	48"W x 14 5/8"D x 15"H, 2 Doors	H105WMH48P	89	12.6	\$1040	\$25	\$30
	Wall Mounted Open Hutch with Cubby						
	72"W x 14 5/8"D x 20"H, 2 Doors	H105WMH72PC	162	21.3	\$1400	\$35	\$35
	66"W x 14 5/8"D x 20"H, 2 Doors	H105WMH66PC	151	19.6	\$1282	\$30	\$30
	60"W x 14 5/8"D x 20"H, 2 Doors	H105WMH60PC	140	14.7	\$1161	\$30	\$30
	48"W x 14 5/8"D x 20"H, 2 Doors	H105WMH48PC	117	12.6	\$1040	\$25	\$30

NOTES:

- Wall attachment methodology: horizontally mounted, interlocking brackets.
- Wall mounted storage cabinet door design overlaps end panels so that when multiple units are placed side-by-side they appear as one continuous unit.
- Laminate doors are non-locking.
- Horizontal interlocking rails are included; due to varying types of walls, installers are responsible for selecting and supplying the appropriate fasteners. widths differ slightly from wall mounted storage cabinet widths. For applications where multiple wall mounted storage cabinets are placed side-by-side, the preferred solution may be to utilize a larger size.
- ❗ Wall mounted storage cabinet attachment requires individual cabinets be secured by a minimum of two wall mounting locations/studs.
- ❗ Wall mounted storage cabinets are designed for interior and perimeter walls that are constructed with wood or metal studs.
- ❗ The HON Company is not responsible for any liabilities resulting from wall mounted storage cabinets that are not properly installed.

HOW TO SPECIFY

<p>Select Model Number</p> <p>H 1 0 5 W M H 4 8</p>	<p>Select Laminate Top and Chassis Color</p> <p>See page 236</p> <p>N N</p>	<p>Select Door Front Laminate</p> <p>See page 236</p> <p>N</p>
---	---	--



10500 SERIES™ Shared Components & Accessories

	DESCRIPTION	MODEL	SHIP WEIGHT	CUBE	LIST PRICE BY LAMINATE GRADE	
					L1	L2
	Wall Mounted Open Hutch, Glass Doors					
	72"W x 14 ⁵ / ₈ "D x 15"H, 2 Doors	H105WMH72PG	162	17.5	\$1900	\$1935
	66"W x 14 ⁵ / ₈ "D x 15"H, 2 Doors	H105WMH66PG	115	16.1	\$1782	\$1812
	60"W x 14 ⁵ / ₈ "D x 15"H, 2 Doors	H105WMH60PG	108	14.7	\$1661	\$1691
	48"W x 14 ⁵ / ₈ "D x 15"H, 2 Doors	H105WMH48PG	93	12.6	\$1540	\$1570
	Wall Mounted Open Hutch with Cubby, Glass Doors					
	72"W x 14 ⁵ / ₈ "D x 20"H, 2 Doors	H105WMH72PCG	166	21.3	\$1900	\$1935
	66"W x 14 ⁵ / ₈ "D x 20"H, 2 Doors	H105WMH66PCG	155	19.6	\$1782	\$1812
	60"W x 14 ⁵ / ₈ "D x 20"H, 2 Doors	H105WMH60PCG	144	17.9	\$1661	\$1691
	48"W x 14 ⁵ / ₈ "D x 20"H, 2 Doors	H105WMH48PCG	121	15.2	\$1540	\$1570

NOTES:

- Wall attachment methodology: horizontally mounted, interlocking brackets.
- Wall mounted storage cabinet door design overlaps end panels so that when multiple units are placed side-by-side they appear as one continuous unit.
- Rich woodgrain laminate and frosted doors with silver frames adds a contemporary mixed materials option to the 10500 Series™.
- Horizontal interlocking rails are included; due to varying types of walls, installers are responsible for selecting and supplying the appropriate fasteners. widths differ slightly from wall mounted storage cabinet widths. For applications where multiple wall mounted storage cabinets are placed side-by-side, the preferred solution may be to utilize a larger size.
- ! Wall mounted storage cabinet attachment requires individual cabinets be secured by a minimum of two wall mounting locations/studs.
- ! Wall mounted storage cabinets are designed for interior and perimeter walls that are constructed with wood or metal studs.
- ! The HON Company is not responsible for any liabilities resulting from wall mounted storage cabinets that are not properly installed.

HOW TO SPECIFY

<p>Select Model Number</p> <p>H 1 0 5 W M H 6 6 P G .</p>	<p>Select Laminate Top and Chassis Color</p> <p>See page 236</p> <p>N N</p>
---	---

10500 SERIES™

Storage

GSA SIN 33721 EXCEPT AS NOTED



Icon Legend on page 19

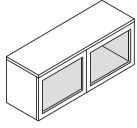

DESCRIPTION	MODEL	SHIP WEIGHT	CUBE	LIST PRICE BY LAMINATE GRADE	
				L1	L2
Wall Mounted Storage Cabinet, Frosted Doors with Silver Frame					
48"W x 14 ⁵ / ₈ "D x 17 ¹ / ₂ "H	H105383G	114.0	13.9	\$1328	\$1353
42"W x 14 ⁵ / ₈ "D x 17 ¹ / ₂ "H	H105382G	97.0	12.3	\$1121	\$1146
36"W x 14 ⁵ / ₈ "D x 17 ¹ / ₂ "H	H105381G	87.0	10.7	\$1048	\$1073
30"W x 14 ⁵ / ₈ "D x 17 ¹ / ₂ "H	H105380G	73.0	9.1	\$997	\$1022

NOTES: Door design overlaps end panels so that when multiple units are placed side-by-side they appear as one continuous unit. Product placement can be aligned to match the height of storage cabinets, wardrobes and towers. Equipped with self-closing, adjustable side-hinged doors. The 30", 36", and 42"W units have two doors; the 48"W has three doors. Frosted door units do not have a lock option. Wall attachment methodology: horizontally mounted, interlocking brackets. widths differ slightly from wall mounted storage cabinet widths. For applications where multiple wall mounted storage cabinets are placed side-by-side, the preferred width may be to utilize a larger size.

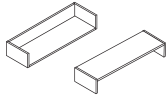

Not available in two-tone laminate



DESCRIPTION	MODEL	SHIP WEIGHT	CUBE	L1	L2
Wall Mounted Open Shelf					
48"W x 9 ⁷ / ₈ "D x 4 ³ / ₄ "H	H105363	18.0	1.2	\$309	\$329
42"W x 9 ⁷ / ₈ "D x 4 ³ / ₄ "H	H105362	16.0	0.8	\$280	\$300
36"W x 9 ⁷ / ₈ "D x 4 ³ / ₄ "H	H105361	14.0	0.8	\$254	\$269
30"W x 9 ⁷ / ₈ "D x 4 ³ / ₄ "H	H105360	12.0	0.8	\$241	\$256

NOTES: Ideal for books, photographs, and mementos up to 9"D. Two attachment orientation options, open ended shelf or shelf with book ends. Available in woodgrain or solid color laminates only. No patterns. No two-tone combinations. Simple assembly.

SPECIFYING EXAMPLE: H105363.N

NOTES:

- Easy-care, scratch-, spill- and stain-resistant laminate over solid core high-performance particleboard.
- Stacked paper management (model HLVPM2), which is 32¹/₂"W, is compatible with the 30"W and 36"W wall mounted storage cabinets.
- ! Wall mounted storage cabinet attachment requires individual cabinets be secured by a minimum of two wall mounting locations/studs.
- ! Wall mounted storage cabinets are designed for interior and perimeter walls that are constructed with wood or metal studs.
- ! The HON Company is not responsible for any liabilities resulting from wall mounted storage cabinets that are not properly installed.

DESCRIPTION	MODEL	SHIP WEIGHT	CUBE	LIST PRICE
LED Task Lights				
31" LED Light with Power Supply (Single)	HLED31AS	1.5 Ⓞ	0.09	\$565
17" LED Light with Power Supply (Single)	HLED17AS	1.2 Ⓞ	0.05	\$420
OPEN MARKET				
31" LED Light with Power Supply for Daisy-chain (Starter)	HLED31A	1.4 Ⓞ	0.09	\$620
17" LED Light with Power Supply for Daisy-chain (Starter)	HLED17A	1.0 Ⓞ	0.05	\$462
31" LED Light with 8" Jumper Cord for Daisy-chain (Follower)	HLED31AUO	1.0 Ⓞ	0.05	\$502
17" LED Light with 8" Jumper Cord for Daisy-chain (Follower)	HLED17AUO	1.0 Ⓞ	0.03	\$377
Undercabinet Occupancy Sensor with 1" End to End Connector	HLEDOSA	0.2 Ⓞ	0.01	\$89

NOTES: To use the daisy chain application, must start with model HLED17A or HLED31A. No finish specification required. Attaches magnetically to underside of overhead storage, or attaches with provided screws or double-sided tape. Occupancy sensor attaches to a single or starter LED light and will automatically turn the light off after no motion is detected for 30 minutes. Just like all the LED light models, the occupancy sensor features a soft-touch on/off switch. LED task lights have a lifetime of 50,000 hours and have a dimmer feature that allows the user to adjust the amount of light output. For additional information see page 842.



Refer to page 842

OPEN MARKET

Recessed Task Light , 46 ¹ / ₂ "W x 3 ¹ / ₈ "D, for Models H105327, H10534, H10533 and H105324	HH870960	12.0 Ⓞ	1.1	\$270
Recessed Task Light , 34 ⁵ / ₈ "W x 3 ¹ / ₈ "D, for Models H105323, H105322, H105382 and H105383	HH870942	10.0 Ⓞ	0.9	\$250
Recessed Task Light , 22 ⁷ / ₈ "W x 3 ¹ / ₈ "D, for Models H105321, H105380 and H105381	HH870930	7.0 Ⓞ	0.6	\$231

NOTES: For additional information see page 842.

HOW TO SPECIFY

Select Model Number

H 1 0 5 3 8 3 G .

Select Laminate Top and Chassis Color

See pages 236-237

H H



10500 SERIES™ Shared Components & Accessories

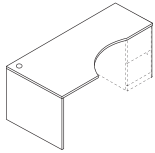

Right-hand model
H105815R shown



DESCRIPTION

Extended Corner Unit

24" W x 36" D x 72" W x 24" D x 29½" H, Right (shown)
24" D x 72" W x 36" D x 24" W x 29½" H, Left

MODEL

H105815R
H105816L

SHIP WEIGHT

184
184

CUBE

7.0
7.0

LIST PRICE BY LAMINATE GRADE

L1

\$1074
\$1074

L2

\$1119
\$1119

NOTES: Intended for use with returns or bridges. Can be used freestanding. The 17" user side dimension is designed to accommodate 10500 Series™ modular or mobile pedestals up to 15¼" W. One grommet in top and one cord pass-through grommet in modesty panel. See pages 268-272 for optional stack-ons and . Extended corner units (H105815R and H105816L) can be used with 36" W return shell (H105680) to achieve a 6' x 6' layout.

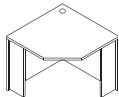
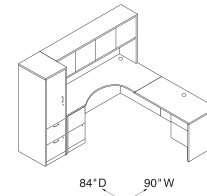
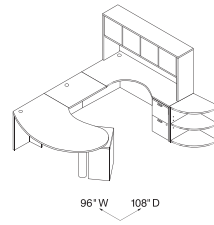
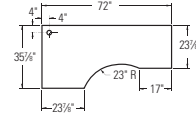

Corner Unit

24" x 36" x 36" x 24" x 29½" H

H105811

130

3.1

\$773

\$808

NOTES: Intended for use with 24" D x 29½" H returns or bridges. Can be used freestanding. 36" corner unit (H105811) can be used with two 36" W return shells (H105680) to achieve a 6' x 6' layout.

⚠ Not designed to attach to returns or bridges manufactured prior to 5/24/99.

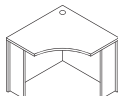
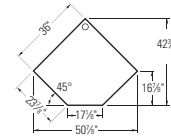

Curved Corner Unit

18" x 36" x 36" x 18" x 29½" H

H105810

128

5.4

\$773

\$808

NOTES: Can be used freestanding.

⚠ Designed to be used with curved returns only.

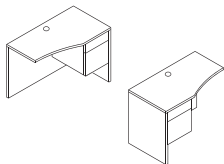

Curved Return — box/file

42" W x 18-24" D x 29½" H, Right
42" W x 24-18" D x 29½" H, Left

H105817R
H105818L

134
134

20.5
20.5

\$837
\$837

\$877
\$877

NOTES: Pedestal locks. One cord grommet in top; one pass-through grommet in top center of modesty panel. H105327 stack-on storage (78" W) can be used to span corner unit and return. H105322 stack-on storage (42" W) can be used on return. See page 269.

⚠ Designed to be used with curved corner unit only.

⚠ Not designed to be used freestanding.

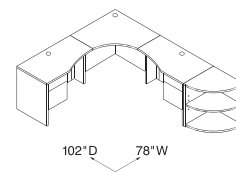
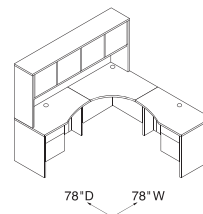

NOTES:

- Shared components shown on this page can be used with modular components shown on pages 244-260, full pedestal models shown on pages 261-262, and 3/4 pedestal models shown on pages 263-264.
- Mobile pedestals, shown on page 276, work well in a variety of configurations.
- End cap bookshelf units are ideal for books and personal items — see page 279.
- For work-in-process paper management tools, see pages 282-283.
- For 10500 Series™ matching occasional tables, use the H80191, H80192, and H80193 on page 284.
- For conference table options, see the Preside® table tops and bases on pages 774-779.
- Mobile table quickly provides additional worksurface space, see page 266.
- See pages 265-288 for shared components.

HOW TO SPECIFY

Select Model Number

H 1 0 5 8 1 5 R .

Select Laminate Top and Chassis Color

See pages 236-237

N N





10500 SERIES™

Shared Components & Accessories

GSA SIN 33721

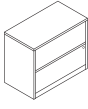
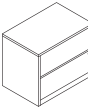
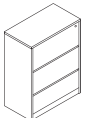
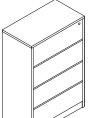

Icon Legend on page 19

	DESCRIPTION	MODEL	SHIP WEIGHT	CUBE	LIST PRICE BY LAMINATE GRADE	
					L1	L2
	Box/Box/File Mobile Pedestal (with core removable lock) 15 $\frac{3}{4}$ "W x 22 $\frac{3}{4}$ "D x 28 $\frac{3}{8}$ "H — use freestanding or under 24"D, 30"D and 36"D modular shells NOTES: Top box drawer does not lock. File drawer includes hangrails.	H105102	121	8.5	\$854	\$894
	File/File Mobile Pedestal (with core removable lock) 15 $\frac{3}{4}$ "W x 22 $\frac{3}{4}$ "D x 28 $\frac{3}{8}$ "H — use freestanding or under 24"D, 30"D and 36"D modular shells NOTES: File drawers include hangrails.	H105104	121	8.4	\$854	\$894
	Box/File Mobile Pedestal (with core removable lock) 15 $\frac{3}{4}$ "W x 18 $\frac{7}{8}$ "D x 21 $\frac{1}{8}$ "H — use freestanding or under 20"D, 24"D, 30"D and 36"D modular shells	H105106	65	5.8	\$714	\$744
	Shelf/Box/File Mobile Pedestal (with core removable lock) 15 $\frac{3}{4}$ "W x 18 $\frac{7}{8}$ "D x 28 $\frac{3}{8}$ "H — use freestanding or under 20"D, 24"D, 30"D and 36"D modular shells NOTES: Interior dimensions of the open storage area of the Shelf/Box/File model are 14 $\frac{1}{8}$ "W x 16 $\frac{3}{4}$ "D x 6 $\frac{5}{8}$ "H.	H105109	73	7.3	\$786	\$826
	Lateral File (with core removable lock) 36"W x 20"D x 59 $\frac{1}{8}$ "H — four drawer 36"W x 20"D x 45 $\frac{1}{2}$ "H — three drawer 36"W x 24"D x 29 $\frac{1}{2}$ "H — two drawer 36"W x 20"D x 29 $\frac{1}{2}$ "H — two drawer NOTES: Includes hangrails, mechanical interlock and in H10563 and H105690, a counterweight. Stack-on storage (H105321) and bookcase hutch (H105292) can be used with H10563 and H105690. Interlock inhibits the extension of more than one drawer from opening at a time. Model H105690 aligns with 24"D credenzas and returns.	H10516	305	31.0	\$2105	\$2175
		H10517	240	23.2	\$1598	\$1663
		H105690	191	17.6	\$1023	\$1078
		H10563	170	15.6	\$973	\$1023

NOTES:

- For additional components that can be shared with 10500 Series™, see pages 265-288.
- Mobile pedestals feature clean styling with hidden casters. Versatile designs roll easily and work well in a variety of configurations. Can be used freestanding, under modular shells, or with 10500 Series™ component worksurfaces and supports.
- 24"D lateral file, storage cabinet, and bookcase models align evenly with credenzas and returns to provide linear layout continuity.
- At 45 $\frac{1}{2}$ "H, the three-drawer lateral file can be used as a standing-height worksurface or to support office equipment.
- Drawers operate on full extension, ball-bearing suspensions to ensure smooth, quiet, long-lasting operation.
- File drawer design includes integrated hangrails for side-to-side letter or legal filing; and front-to-back for letter filing.
- Mobile printer/fax cart shown on page 260 is ideal for limited space.

HOW TO SPECIFY

Select Model Number H 1 0 5 1 0 2 .	Select Laminate Top and Chassis Color See pages 236-237 N N
---	--

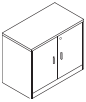
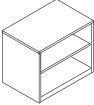
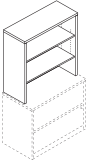
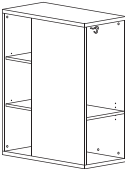
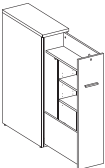

10500 SERIES™ Shared Components & Accessories

	DESCRIPTION	MODEL	SHIP WEIGHT	CUBE	LIST PRICE BY LAMINATE GRADE	
					L1	L2
	Storage Cabinet with Doors (with core removable lock)					
	36"W x 24"D x 29½"H 36"W x 20"D x 29½"H	H105290 H105291	168 147	17.6 15.0	\$927 \$781	\$982 \$831
	NOTES: Includes one adjustable shelf. Shelf adjusts in ¼" increments with a total range of 5". Stack-on storage (H105321), and bookcase hutch (H105292) can be used with H105291 or H105290. Model H105290 aligns with 24"D credenzas and returns.					
	Bookcase					
	36"W x 24"D x 29½"H, 2-Shelf, 1-Adjustable	H105531	102	18.4	\$757	\$772
	NOTES: Adjustable shelf is 22"D and adjusts in ¼" increments, with a total range of 5". 24" depth aligns evenly with 24"D credenzas, credenza shells, returns, return shells, and wardrobe/storage cabinets to provide linear layout continuity. Adjustable leveling glides. Accommodates the 36"W stack-on storage or bookcase hutch. Ships fully assembled.					
	Bookcase Hutch (for use with lateral file models H10563/H105690, storage cabinet models H105291/H105290, and bookcase model H105531)					
	36"W x 14⅝"D x 37⅝"H	H105292	103	3.6	\$570	\$585
	NOTES: Cord pass-through gap behind shelves and a 1⅝"H full-width cord management slot at the bottom of the back panel. Two shelves are adjustable in ¼" increments with a total range of 17½"H.					
	Multi-Use Stack-On Storage					
	36"W x 18"D x 45⅝"H	H105310	142	21.9	\$1059	\$1094
	NOTES: Non-handed. Design features user's side bookcase and end access mixed storage compartment. Three fixed bookcase compartments, each 12"W x 13¾"H. Versatile mixed storage area includes two coat hooks and two shelves; one adjustable in ¼"H increments with a total range of 5" (shelf count includes bottom of the unit). For use on worksurfaces 36" or wider and 18" or deeper. Total height, in combination with low credenza, is 66⅝". Accepts models HL1536SOMB or HL1530SOMB (sold separately). Ships fully assembled.					
	DESCRIPTION	MODEL	SHIP WEIGHT	CUBE	L1 LIST	L2 UPCHARGES CHASSIS FRONTS
	Slide Out Tower					
	12"W x 30"D x 50"H, Right	H105ST123050R	215	13.8	\$3000	\$60 \$20
	12"W x 30"D x 50"H, Left	H105ST123050L	215	13.8	\$3000	\$60 \$20
	12"W x 24"D x 50"H, Right	H105ST122450R	182	11.4	\$2705	\$50 \$20
	12"W x 24"D x 50"H, Left	H105ST122450L	182	11.4	\$2705	\$50 \$20
	NOTES: Wardrobe space contains one coat hook. Storage space includes three shelves; two are adjustable in 2½" increments. Door access left or right models available. Equipped with HON "One Key" interchangeable core removable locks. Standard with Black linear pull.					

OPEN MARKET

NOTES:

- For additional components that can be shared with 10500 Series™, see pages 265-288.
- Versatile mobile pedestals roll easily and work well in a variety of configurations. Can be used freestanding, under modular shells, or with 10500 Series™ component worksurfaces and supports.
- 24"D lateral file, storage cabinet, and bookcase models align evenly with credenzas and returns to provide linear layout continuity.
- Mobile printer/fax cart shown on page 260 is ideal for limited space.

HOW TO SPECIFY

<p>Select Model Number</p> <p>H 1 0 5 2 9 1 .</p>	<p>Select Laminate Top and Chassis Color</p> <p>See pages 236-237</p> <p>N N</p>			
<p>Select Model Number</p> <p>H 1 0 5 S T 1 2 3 0 5 0 R .</p>	<p>Select Laminate Top and Chassis Color</p> <p>See page 236</p> <p>N N .</p>	<p>Select Door Front Laminate</p> <p>See page 236</p> <p>N .</p>	<p>Select Pull and Color</p> <p>L Linear P Black</p> <p>L P .</p>	<p>Select Lock Option</p> <p>Not available on Open Credenzas</p> <p>L Lock X Omit Lock (deduct \$20)</p> <p>L</p>



Icon Legend on page 19

10500 SERIES™ Shared Components & Accessories

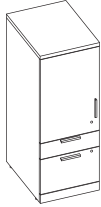

DESCRIPTION

Storage Wardrobe

- 24"W x 24"D x 50"H, Right
- 24"W x 24"D x 50"H, Left
- 24"W x 20"D x 50"H, Right
- 24"W x 20"D x 50"H, Left
- 18"W x 24"D x 50"H, Right
- 18"W x 24"D x 50"H, Left
- 18"W x 20"D x 50"H, Right
- 18"W x 20"D x 50"H, Left

MODEL

- H105LT242450CBFR**
- H105LT242450CBFL**
- H105LT242050CBFR**
- H105LT242050CBFL**
- H105LT182450CBFR**
- H105LT182450CBFL**
- H105LT182050CBFR**
- H105LT182050CBFL**

SHIP WEIGHT

- 202
- 202
- 178
- 178
- 168
- 168
- 147
- 147

CUBE

- 21.3
- 21.3
- 17.9
- 17.9
- 16.2
- 16.2
- 13.7
- 13.7

L1 LIST

- \$2050**
- \$2050**
- \$2000**
- \$2000**
- \$1950**
- \$1950**
- \$1728**
- \$1728**

L2 UPCHARGES
CHASSIS FRONTS

- \$60 \$35**
- \$60 \$35**
- \$50 \$35**
- \$50 \$35**
- \$50 \$30**
- \$50 \$30**
- \$45 \$30**
- \$45 \$30**

NOTES: Spacious design includes a wardrobe closet, storage cabinet, one box drawer, and one file drawer in one compact unit. Wardrobe closet contains a coat rod. Storage cabinet includes two shelves, one is adjustable in 2½" increments. Door hinged left or right models available. Box and file drawers operate on ball-bearing suspensions with full extension. File drawers have high sides to accept hanging folders in letter or legal size. Drawers standard with hangrails. Equipped with HON "One Key" interchangeable core removable locks. Upper lock secures storage cabinet and wardrobe closet doors; lower lock secures file drawers.

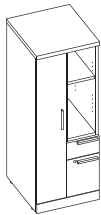

Open Wardrobe

- 24"W x 24"D x 50"H, Right
- 24"W x 24"D x 50"H, Left
- 24"W x 20"D x 50"H, Right
- 24"W x 20"D x 50"H, Left
- 18"W x 24"D x 50"H, Right
- 18"W x 24"D x 50"H, Left
- 18"W x 20"D x 50"H, Right
- 18"W x 20"D x 50"H, Left

- H105LT242450BFR**
- H105LT242450BFL**
- H105LT242050BFR**
- H105LT242050BFL**
- H105LT182450BFR**
- H105LT182450BFL**
- H105LT182050BFR**
- H105LT182050BFL**

- 190
- 190
- 167
- 167
- 161
- 161
- 141
- 141

- 21.3
- 21.3
- 17.9
- 17.9
- 16.2
- 16.2
- 13.7
- 13.7

- \$2000**
- \$2000**
- \$1800**
- \$1800**
- \$1900**
- \$1900**
- \$1678**
- \$1678**

- \$60 \$35**
- \$60 \$35**
- \$50 \$35**
- \$50 \$35**
- \$50 \$30**
- \$50 \$30**
- \$45 \$30**
- \$45 \$30**

NOTES: Spacious design includes a wardrobe closet, open storage, one box drawer, and one file drawer in one compact unit. Wardrobe closet contains a coat rod. Storage cabinet includes two shelves, one is adjustable in 2½" increments. Door hinged left or right models available. Box and file drawers operate on ball-bearing suspensions with full extension. File drawers have high sides to accept hanging folders in letter or legal size. Drawers standard with hangrails. Equipped with HON "One Key" interchangeable core removable locks. Lock secures box and file drawers; wardrobe is non-locking.



Side Access Wardrobe

- 24"W x 24"D x 50"H, Right
- 24"W x 24"D x 50"H, Left
- 24"W x 20"D x 50"H, Right
- 24"W x 20"D x 50"H, Left
- 18"W x 24"D x 50"H, Right
- 18"W x 24"D x 50"H, Left
- 18"W x 20"D x 50"H, Right
- 18"W x 20"D x 50"H, Left

- H105LT242450SBFR**
- H105LT242450SBFL**
- H105LT242050SBFR**
- H105LT242050SBFL**
- H105LT182450SBFR**
- H105LT182450SBFL**
- H105LT182050SBFR**
- H105LT182050SBFL**

- 187
- 187
- 166
- 166
- 153
- 153
- 135
- 135

- 21.3
- 21.3
- 17.9
- 17.9
- 16.2
- 16.2
- 13.7
- 13.7

- \$2078**
- \$2078**
- \$1900**
- \$1900**
- \$1966**
- \$1966**
- \$1728**
- \$1728**

- \$60 \$35**
- \$60 \$35**
- \$50 \$35**
- \$50 \$35**
- \$50 \$30**
- \$50 \$30**
- \$45 \$30**
- \$45 \$30**

NOTES: Spacious design includes a wardrobe closet, open side access storage, one box drawer, and one file drawer in one compact unit. Wardrobe closet contains a coat rod. Storage cabinet includes two shelves, one is adjustable in 2½" increments. Door hinged left or right models available. Box and file drawers operate on ball-bearing suspensions with full extension. File drawers have high sides to accept hanging folders in letter or legal size. Drawers standard with hangrails. Equipped with HON "One Key" interchangeable core removable locks. Lock secures box and file drawers; wardrobe is non-locking.

NOTES:

- Broad family of storage components beyond the confines of a desk drawer.
- Locking units equipped with interchangeable core removable locks.
- Adjustable hex leveling glides allow floor-standing furniture to be easily leveled without lifting the unit; glides have ¾" adjustable range.

HOW TO SPECIFY

<p>Select Model Number</p> <p>H 1 0 5 L T 1 8 2 4 5 0 B F R .</p>	<p>Select Laminate Top and Chassis Color</p> <p>See page 236 Kickplates will match chassis color</p> <p>N N .</p>	<p>Select Door Front Laminate</p> <p>See page 236</p> <p>N .</p>	<p>Select Pull and Color</p> <p>L Linear P Black</p> <p>L P .</p>	<p>Select Lock Option</p> <p>L Lock X Omit Lock (deduct \$20)</p> <p>L</p>
--	--	---	--	---



Icon Legend on page 19

10500 SERIES™ Shared Components & Accessories

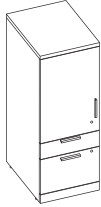

DESCRIPTION

Storage Cabinet
18"W x 24"D x 50"H, Right
18"W x 24"D x 50"H, Left

MODEL

H105LT182450SCBFR
H105LT182450SCBFL

SHIP WEIGHT

158
158

CUBE

16.2
16.2

L1 LIST

\$1575
\$1575

L2 UPCHARGES
CHASSIS FRONTS

\$50 \$30
\$50 \$30

NOTES:

- Versatile unit features a storage cabinet, one box drawer, and one file drawer.
- Storage cabinet includes two shelves, one is adjustable in 2½" increments.
- Door hinged left or right models available.
- File drawers operate on ball-bearing suspensions with full extension.
- File drawers have high sides to accept hanging folders in letter or legal size.
- Drawers standard with hangrails.
- Both the storage cabinet and the file drawers are equipped with a HON "One Key" interchangeable core removable lock.
- Upper lock secures storage cabinet; lower lock secures box and file drawers.
- Broad family of storage components beyond the confines of a desk drawer.
- Locking units equipped with interchangeable core removable locks.
- Adjustable hex leveling glides allow floor-standing furniture to be easily leveled without lifting the unit; glides have ¾" adjustable range.

HOW TO SPECIFY

<p>Select Model Number</p> <p>H 1 0 5 L T 1 8 2 4 5 0 S C B F R .</p>	<p>Select Laminate Top and Chassis Color</p> <p>See page 236 Kickplates will match chassis color</p> <p>N N .</p>	<p>Select Door Front Laminate</p> <p>See page 236</p> <p>N .</p>	<p>Select Pull and Color</p> <p>L Linear P Black</p> <p>L P .</p>	<p>Select Lock Option</p> <p>L Lock X Omit Lock (deduct \$20)</p> <p>L</p>
--	--	---	--	---

10500 SERIES™

Shared Components & Accessories

GSA SIN 33721



Icon Legend on page 19

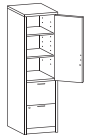

Right-hand model
H105297R shown

DESCRIPTION	MODEL	SHIP WEIGHT	CUBE	LIST PRICE BY LAMINATE GRADE	
				L1	L2
Storage/File Cabinet (with core removable locks)					
18"W x 24"D x 66 $\frac{5}{8}$ "H, Hinged Right (shown)	H105297R	258	22.7	\$1692	\$1767
18"W x 24"D x 66 $\frac{5}{8}$ "H, Hinged Left	H105298L	258	22.7	\$1692	\$1767
NOTES: Versatile unit features a storage cabinet and two file drawers. Storage cabinet includes three shelves, two are adjustable in 2 $\frac{1}{2}$ " increments. Door hinged left or right models available. File drawers operate on ball-bearing suspensions with full extension. File drawers have high sides to accept hanging folders in letter or legal size. Drawers standard with hangrails. Both the storage cabinet and the file drawers are equipped with a HON "One Key" interchangeable core removable lock. Unit height is designed to match credenza or return plus stack-on storage height.					



Doors open 110 degrees
from closed position.

Storage Cabinet/Lateral File (with core removable lock)					
36"W x 24"D x 66 $\frac{5}{8}$ "H	H105293	365	41.0	\$2278	\$2378
NOTES: Storage cabinet is standard with one fixed and two full-width adjustable shelves in top compartment; adjustable shelves can be removed. Overall storage compartment measures 31 $\frac{1}{4}$ "W x 22"D x 36 $\frac{5}{8}$ "H and will accommodate supplies, books and binders, as well as business machines and electronic equipment. Cord pass-through gap behind shelves and grommet in back of the cabinet to facilitate routing cords and reaching wall electrical outlets. Two drawer lateral file on bottom. Lateral file comes with mechanical interlock and hangrails. Cabinet and lateral file lock independently. Unit height is designed to match credenza or return plus stack-on storage height.					



Doors open 110 degrees
from closed position.

Storage Cabinet with Full-width Shelves (with core removable lock)					
36"W x 24"D x 66 $\frac{5}{8}$ "H	H105299	341	39.6	\$2126	\$2226
NOTES: Large storage area includes five, full-width (side-to-side) shelves; three are adjustable in 2 $\frac{1}{2}$ " increments. Unit height matches credenza or return plus stack-on storage height.					

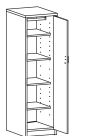

Right-hand model
H105295R shown

Personal Wardrobe/Storage Cabinet (with core removable lock)					
18"W x 24"D x 66 $\frac{5}{8}$ "H, Hinged Right (shown)	H105295R	223	22.9	\$1533	\$1608
18"W x 24"D x 66 $\frac{5}{8}$ "H, Hinged Left	H105296L	223	22.9	\$1533	\$1608
NOTES: Unit is standard with four adjustable shelves, coat rod, and core removable lock. Shelves adjust in 2 $\frac{1}{2}$ " increments. Cabinet can be used as a wardrobe by removing four adjustable shelves. Coat rod can be removed from cabinet for storage only applications. Unit height is designed to match credenza or return plus stack-on storage height.					

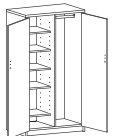

Doors open 110 degrees
from closed position.

Personal Wardrobe/Storage Cabinet (with core removable lock)					
36"W x 24"D x 66 $\frac{5}{8}$ "H	H10530	341	41.0	\$2278	\$2290
NOTES: Spacious design is standard with four adjustable shelves (one shelf is fixed), coat rod and core removable lock which locks both doors. Shelves adjust in 2 $\frac{1}{2}$ " increments. Unit height is designed to match credenza or return plus stack-on storage height.					

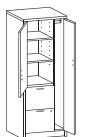

Right-hand model
H105301R shown

Personal Storage Tower (with core removable locks)					
24"W x 24"D x 66 $\frac{5}{8}$ "H, wardrobe Hinged Right, storage cabinet Hinged Left (shown)	H105301R	299	27.9	\$2139	\$2234
24"W x 24"D x 66 $\frac{5}{8}$ "H, wardrobe Hinged Left, storage cabinet Hinged Right	H105302L	299	27.9	\$2139	\$2234
NOTES: Spacious design includes a wardrobe closet, storage cabinet, and two file drawers in one compact unit. Wardrobe closet contains a coat rod. Storage cabinet includes three shelves, two are adjustable in 2 $\frac{1}{2}$ " increments. Door hinged left or right models available. File drawers operate on ball-bearing suspensions with full extension. File drawers have high sides to accept hanging folders in letter or legal size. Drawers standard with hangrails. Equipped with HON "One Key" interchangeable core removable locks. Upper lock secures storage cabinet and wardrobe closet doors; lower lock secures file drawers. Unit height is designed to match credenza or return plus stack-on storage height.					

NOTES:

- Broad family of storage components takes organization way beyond the confines of a desk drawer.
- Locking units equipped with interchangeable core removable locks.
- Adjustable hex leveling glides allow floor-standing furniture to be easily leveled without lifting the unit; glides have $\frac{3}{4}$ " adjustable range.
- See pages 265-288 for shared components.

🔑 Keyed alike cores must be ordered separately — see model HF23B on page 853 — makes re-keying quick and easy.







HOW TO SPECIFY

Select Model Number	Select Laminate Top and Chassis Color
H 1 0 5 2 9 7 R .	See pages 236-237
	N N

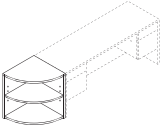

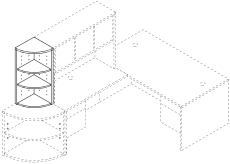
10500 SERIES™

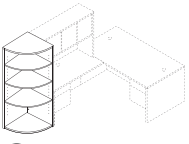
Shared Components & Accessories

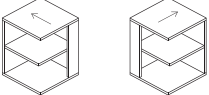
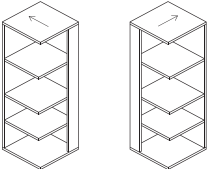
	DESCRIPTION	MODEL	SHIP WEIGHT	CUBE	LIST PRICE BY LAMINATE GRADE	
					L1	L2
 H105532 shown	Bookcase					
	5 Shelf, 36"W x 13 ¹ / ₈ "D x 71"H	H105535	187	25.1	\$825	\$855
	4 Shelf, 36"W x 13 ¹ / ₈ "D x 57 ¹ / ₈ "H	H105534	156	20.2	\$710	\$735
	3 Shelf, 36"W x 13 ¹ / ₈ "D x 43 ³ / ₈ "H	H105533	122	15.6	\$602	\$622
	2 Shelf, 36"W x 13 ¹ / ₈ "D x 29 ⁵ / ₈ "H	H105532	90	11.0	\$474	\$489
	NOTES: Fixed shelves. Inside shelf dimensions on all units is 33 ³ / ₄ "W x 12"D x 13"H. No assembly required.					
 	End Cap Bookshelf (2 shelves, 1 fixed, 1 adjustable. Adjusts in 2¹/₂" increments with a total range of 10"H)					
	24"W x 24"D x 29 ¹ / ₂ "H	H105520	84	2.6	\$603	\$618
	NOTES: Unit is freestanding. Designed to be positioned at the end of 24"D credenzas and returns. Ideal for books, photos, plants and mementos.					
 	End Cap Bookshelf (3 shelves, 1 fixed, 2 adjustable. Adjusts in 2¹/₂" increments with a total range of 25"H)					
	15"W x 15"D x 37 ¹ / ₈ "H	H105523	53	2.2	\$519	\$534
	NOTES: Unit is designed to be positioned at the end of stack-on storage and on top of model H105520. Combined height of models H105520 and H105523 matches credenza or return plus stack-on storage height. Can be used freestanding.					
 	End Cap Bookshelf					
	24"W x 24"D x 66 ⁵ / ₈ "H	H105524	164	4.8	\$1005	\$1030
	NOTES: Designed to be positioned at the end of 24"D credenzas with stack-on storage, 24"D returns with stack-on storage, 24"D storage/file cabinet, 24"D storage cabinet/lateral file, 24"D wardrobe/storage cabinets, or the 24"D personal storage tower. Unit has four shelves, three are adjustable in 2 ¹ / ₂ " increments, with a total range of 45"H; bottom shelf is fixed.					
 Model H105525R Model H105526L	Square End Cap Bookshelf — 2-Fixed Shelves					
	24"W x 24"D x 29 ¹ / ₂ "H, Right 24"W x 24"D x 29 ¹ / ₂ "H, Left	H105525R H105526L	92 92	3.6 3.6	\$598 \$598	\$613 \$613
 Model H105527R Model H105528L	Square End Cap Bookshelf — 4-Fixed Shelves					
	24"W x 24"D x 66 ⁵ / ₈ "H, Right 24"W x 24"D x 66 ⁵ / ₈ "H, Left	H105527R H105528L	172 172	5.9 5.9	\$959 \$959	\$984 \$984
	NOTES: Units are freestanding. Designed to be positioned next to 24"D models or as a corner bookcase. End cap, left: grain direction on top aligns with grain direction on tops of left pedestal returns and left credenza models or when positioned to the left side of credenzas with doors or kneespace models. End cap, right: grain direction on top aligns with grain direction on tops of right pedestal returns and right credenza models or when positioned to the right side of credenzas with doors or kneespace models.					

NOTES:

- For 36"W x 24"D x 29¹/₂"H two-shelf bookcase, to align evenly with credenzas and returns, see page 277.

HOW TO SPECIFY

Select Model Number H 1 0 5 5 3 2	Select Laminate Top and Chassis Color See pages 236-237 N N
---	--

10500 SERIES™

Shared Components & Accessories

GSA SIN 33721



Icon Legend on page 19

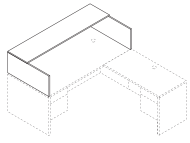

DESCRIPTION	MODEL	SHIP WEIGHT	CUBE	LIST PRICE BY LAMINATE GRADE	
				L1	L2
Reception Station with Transaction Counter, for 72" W x 36" D Desk, or Desk Shell, with rectangle top 72"W x 36"D x 14¼"H	H105720	92	3.0	\$504	\$539

NOTES: For desk tops without grommets, see field installable grommet kit, model HFLDGRMT on page 287. Transaction counter organizer (HTCOL52) fits under/inside of transaction counter (see below).

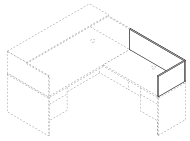

Reception Station for 42" W x 24" D Return or Return Shell 42"W x 24"D x 13"H	H105722	2	1.0	\$253	\$273
---	----------------	---	-----	--------------	--------------

Reception Station for 48" W x 24" D Return or Return Shell 48"W x 24"D x 13"H	H105721	25	3.6	\$288	\$308
---	----------------	----	-----	--------------	--------------

NOTES: For return tops without grommets, see field installable grommet kit, model HFLDGRMT on page 287. Not available in two-tone laminate. Designed specifically for use with Reception Station with Transaction Counter, model H105720.

SPECIFYING EXAMPLE: H105722.N

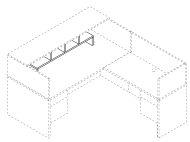

DESCRIPTION	MODEL	SHIP WEIGHT	CUBE	LIST PRICE
Transaction Counter Organizer 48¾"W x 11⅞"D x 13"H	HTCOL52	24	1.1	\$283

NOTES: Fits under reception station with transaction counter model H105720 reception desk shell (H105724), and work organizer models H10537 and H10536.

! Black only.

SPECIFYING EXAMPLE: HTCOL52.P

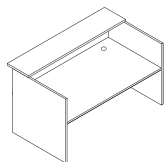

DESCRIPTION	MODEL	SHIP WEIGHT	CUBE	LIST PRICE BY LAMINATE GRADE	
				L1	L2
Reception Desk Shell, with rectangle top 72"W x 39⅞"D x 44⅞"H	H105724	294	17.0	\$1077	\$1132

NOTES: Non-handed design. Integrated 18⅞"D transaction counter with a 4" full-width overhang. Two cord management grommets in top for routing and hiding wires and cables. Transaction counter organizer model TCOL52 fits under/inside transaction counter. When a two-tone color combination is specified, the first designator defines the transaction countertop and the desk worksurface.

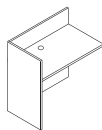

Reception Station Return Shell 42"W x 24⅜"D x 42⅝"H	H105726	131	17.0	\$750	\$785
---	----------------	-----	------	--------------	--------------

NOTES: Non-handed design for use with reception desk shell. One cord management grommet in top for routing and hiding wires and cables. Woodgrain on approach side is vertical to match grain direction on end panels of reception station desk. Designed specifically for use with Reception Desk Shell, model H105724.

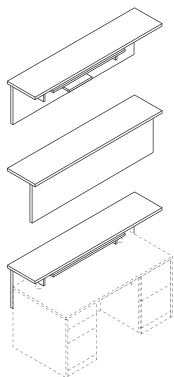

Transaction Counter for Reception Desk 66"W x 14⅝"D x 14¼"H	H105729	100	4.2	\$626	\$651
---	----------------	-----	-----	--------------	--------------

NOTES: Off-the-worksurface solution designed for use with 72"W or 66"W desks or desk shells with a 1⅞" thick rectangle top and a full-width conference (approach-side) overhang of 4½"D minimum. Choose from two height options at time of installation; 13⅞"H (upper position) or 5½"H (lower position) above the desktop. Attaches easily and securely without any drilling or double-sided tape on the worksurface. Grain direction: side-to-side on countertop; horizontal on approach and users side vertical panel.

NOTES:

- Three welcoming reception station designs to choose from — stack-on enclosure, full-to-floor shell, or front-suspended counter.
- Versatile mobile office table is ideal for additional worksurface space, meetings, and special projects. See page 266.
- For 10500 Series™ matching reception area furniture, see Occasional Tables on page 284.
- See pages 265-288 for shared components.

HOW TO SPECIFY

Select Model Number <input type="text" value="H105720."/>	Select Laminate Top and Chassis Color See pages 236-237 <input type="text" value="NN"/>
---	--

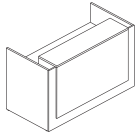

DESCRIPTION	MODEL	SHIP WEIGHT	CUBE	L1 LIST	L2 UPCHARGES		ACCENT PANEL
					WORKSURFACE	CHASSIS	
Reception Desk with Transaction Counter 72"W x 36 3/4"D x 44"H	HLAM3772RD	324	13.5	\$1474	\$35	\$70	\$25

NOTES: Non-handed. Counter measures 60"W x 15 1/4"D. Flat edge (G) matches 10500 Series™. For beaded (B) and tri-oval (V) edge shapes, the transaction counter is profiled on the approach and user sides, and the desk worksurface is profiled on the user's side. Beaded (B) and tri-oval (V) edges are available in L1 woodgrains colors only. Smooth and flat (G) edge available in all woodgrains and solid colors. Vertical grain on approach side and front accent panel for L1 laminates except Kingswood Walnut and Florence Walnut. Horizontal grain on L2 laminates and Kingswood and Florence Walnut. Vertical grain on end panels and horizontal grain on worksurface and transaction counter. Two worksurface cord management grommets for routing and hiding wires and cables; can be specified in Black (P) or Platinum (TI) finish.

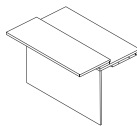

Reception Return with 32'H Transaction Counter 48 1/4"W x 32 7/8"D x 32"H	HLAM3348RR	145	3.7	\$829	\$35	\$35	N/A
---	-------------------	-----	-----	--------------	-------------	-------------	------------

NOTES: Non-handed. For use with HLAM3772RD and Reception Desk Shell (H105724). Counter facilitates accessibility; measures 48"W x 12"D x 32"H. Flat edge (G) matches 10500 Series™. For beaded (B) and tri-oval (V) edge shapes, the transaction counter is profiled on the approach side, and the return worksurface is profiled on the user's side. All other edges are flat banded. Beaded (B) and tri-oval (V) available in L1 woodgrain colors only. Flat edge (G) available in all woodgrains and solid colors. Pattern laminates do not have matching edge color; patterns can be specified with woodgrain or solid edge. Vertical grain on approach side, end panel, worksurface, and transaction counter. Assembly required.

Specify: Model.Edge Profile & EdgeColor.Worksurface & Counter Color.Chassis Color

SPECIFYING EXAMPLE: HLAM3348RR.GN.N.N

HOW TO SPECIFY

<p>Select Model Number</p> <p>HLAM3772RD</p>	<p>Select Edge Profile and Edge Color</p> <p>See page 237</p> <p>GN</p>	<p>Select Grommet Color</p> <p>P Black TI Platinum Not specified for model HLAM3348RR</p> <p>P</p>	<p>Select Worksurface Laminate</p> <p>See page 236</p> <p>N</p>	<p>Select Chassis Laminate</p> <p>See page 236</p> <p>N</p>	<p>Select Accent Panel Laminate</p> <p>See page 236 Not specified for model HLAM3348RR</p> <p>LDW1</p>
---	--	---	--	--	---

10500 SERIES™

Shared Components & Accessories

GSA SIN 33721

ABI

Icon Legend on page 19

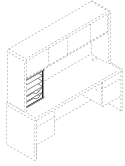

Not available in two-tone laminate



DESCRIPTION	MODEL	SHIP WEIGHT	CUBE	LIST PRICE BY LAMINATE GRADE	
				L1	L2
Vertical Paper Manager 14 ⁷ / ₈ "W x 10 ⁷ / ₈ "D x 19 ³ / ₈ "H NOTES: Keeps papers, files, and books neatly organized and within easy reach from a seated position. Designed for desk, credenza, and return tops. Fits under stack-on storage models. Two pullout drawers and three fixed shelves. Unit can also be used with 10700 Series™, Valido®, and 94000 Series™. When used in conjunction with wall mounted storage cabinets, the top of the wall mounted storage cabinets must be positioned a minimum of 68" above the floor. For additional information see page 844. SPECIFYING EXAMPLE: HLVPM1.N	HLVPM1	27	2.8	\$327	\$337

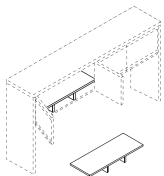

DESCRIPTION	MODEL	SHIP WEIGHT	CUBE	LIST PRICE
Stacked Paper Management 32 ¹ / ₂ "W x 12 ⁵ / ₈ "D x 4 ¹ / ₄ "H NOTES: Segments and organizes stack-on and wall mount storage compartments, as well as bookcase shelves. In some cases, installation may require removing the stack-on or wall mount storage doors. For additional information see page 845. ! Black only.	HLVPM2	22	1.25	\$163

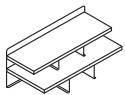

Not available in two-tone laminate



DESCRIPTION	MODEL	SHIP WEIGHT	CUBE	LIST PRICE BY LAMINATE GRADE	
				L1	L2
Desktop Storage Terrace 26 ¹ / ₂ "W x 12 ⁵ / ₈ "D x 10 ¹ / ₄ "H NOTES: Keeps work-in-process, priority files, loose pages, and mail neatly organized and in view. Mixed material design comprised of sturdy laminate shelves with metal back and support panels. Not available in two-tone laminate combination or pattern laminate colors. Choose from Platinum Metallic (TI), Black (P), and Charcoal (S) for the metal components. Sized to fit in stack-on and wall mounted storage cabinets in 10500, 10700, Valido, 94000, and 38000 Series. Fits in Voi stack-on and overhead cabinets except for 48"W or smaller sliding door models. For additional information see page 844. Specify: Model.Laminate.Paint SPECIFYING EXAMPLE: HLDST1.N.TI	HLDST1	24	1.1	\$306	\$316



Refer to page 106 for Center Drawer compatibility information

DESCRIPTION	MODEL	SHIP WEIGHT	CUBE	L1	L2
				LIST PRICE	LIST PRICE
Angled Wood Center Drawer 26" x 15 ³ / ₈ " 22" x 15 ³ / ₈ " NOTES: Specify laminate for drawer. Model H1522 can be used on peninsulas with modesty panel, model H10528. For additional information see page 832.	H1526	12	1.2	\$198	\$213
	H1522	11	1.1	\$184	\$199

NOTES:

- For 10500 Series™ matching Occasional Tables, see page 284.
- Vertical paper manager designed for desk, credenza, and return tops. Fits under stack-on storage.
- Stacked paper management segments and organizes stack-on and wall mount storage compartments, as well as bookcase shelves. Unit can be used in models H105327, H10534, H105322, H105321, H105382 and H105381.
- Desktop Storage Terrace is for use on the tops of 29¹/₂"H desks, credenzas, and returns.
- Desktop Storage Terrace features six storage sections plus top display shelf.
- Desktop Storage Terrace includes protective, non-slip pads on the base.
- See pages 265-288 for shared components.

! In some cases, installation of Stacked Paper Management may require removing the stack-on or wall mount storage doors.

HOW TO SPECIFY

Select Model Number

H L V P M 1 .



Select Laminate

See pages 236-237

N

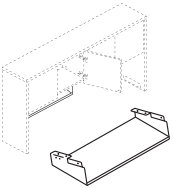
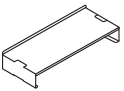

10500 SERIES™ Shared Components & Accessories

	DESCRIPTION	MODEL	SHIP WEIGHT	CUBE	LIST PRICE
	<p>Hanging Paper Shelf 28¹/₁₆"W x 11⁷/₁₆"D x 4⁵/₁₆"H</p> <p>NOTES: Maximizes worksurface space; de-clutters desktop while placing priority communications and active project folders within easy reach. Angled design allows contents to be distinguished at a glance. Mixed material styling features strong painted metal frame with a frosted shelf.</p> <p>Attaches quickly and easily to stack-on and wall mount storage models in the following series: 10500, 10700, Valido, 94000, and Voi (except the 36"W overhead hutch with O-legs or panel mount brackets). Not for use with 38000 Series.</p> <p>For additional information see page 824. Specify: Model.Paint</p> <p>SPECIFYING EXAMPLE: HHPS1.T1</p>	HHPS1	7	2.9	\$198
	<p>Desktop Paper Shelf 28¹/₁₆"W x 11⁵/₁₆"D x 5"H</p> <p>NOTES: Organizer shelf provides a place and space for work-in-process and piling to keep worksurfaces neat and tidy. Convenient, scalable design with interlocking side supports allow two units to be stacked and integrated. Durable painted metal frame with a frosted shelf; mixed material styling matches hanging paper shelf.</p> <p>Can also be used inside select overhead storage, including the following stack-on with hinged door models: 10500 and Valido 36", 42", 66", 72", 78"W and 10700 68⁵/₁₆"W.</p> <p>For additional information see page 824. Specify: Model.Paint</p> <p>SPECIFYING EXAMPLE: HDPS1.T1</p>	HDPS1	7	2.9	\$198
	<p>Storage Cube 12"W x 12"D</p> <p>NOTES: For additional information see page 846.</p> <p>SPECIFYING EXAMPLE: HLSSL1212.P8S</p>	HLSSL1212	1	0.3	\$294

**NOTES:**

- For 10500 Series™ matching Occasional Tables, see page 284.
- Desktop Paper Shelf includes protective, non-slip pads on the base.
- Paper Shelf can stack two-high.
- Hanging Paper Shelf attaches quickly and easily (screws included).
- See pages 265-288 for shared components.
- For additional information see pages 845-846.

HOW TO SPECIFY

<p>Select Model Number</p> <p>HHPS1.T1</p>	<p>Select Paint Color</p> <p>See page 171</p> <p>T1</p>
---	--

10500 Series™ Laminate Occasional Tables

GSA SIN 33721



Icon Legend on page 19

	DESCRIPTION	MODEL	SHIP WEIGHT	CUBE	LIST PRICE
	Coffee Table 48"W x 20"D x 16"H	H80191	48 Ⓢ	3.4	\$475
	Corner Table 24"W x 24"D x 20"H	H80192	35 Ⓢ	2.1	\$410
	End Table 24"W x 20"D x 20"H	H80193	29 Ⓢ	1.8	\$392

Laminate Occasional Tables (H80191, H80192 and H80193)

Woodgrain	Solid	Patterned	Two-Tone	
Bourbon Cherry (HH) Cognac (COGNCOGN) Florence Walnut (LFWILFW1) Harvest (CC) Kingswood Walnut (LKIILKI1) Mahogany (NN) Mocha (MOCHMOCH) Natural Maple (DD) Pinnacle (PINCPINC) Shaker Cherry (FF) Sterling Ash (LSA1LSA1)	Black (PP) Charcoal (SS) Designer White (LDWILDW1) Loft (LOFTLOFT)	Canyon Zephyr (K9) Desert Zephyr (K8) Grey Tigris (L6*) Sheer Mesh (A5) Silver Mesh (B9) *Select edge/apron/leg color Black (P) Bourbon Cherry (H) Charcoal (S) Cognac (COGN) Designer White (LDW1) Florence Walnut (LFW1) Harvest (C) Kingswood Walnut (LKI1) Mahogany (N) Mocha (MOCH) Natural Maple (D) Pinnacle (PINC) Shaker Cherry (F) Sterling Ash (LSA1)	Black/Charcoal (PS) Black/Designer White (PLDW1) Bourbon Cherry/Black (HP) Bourbon Cherry/Charcoal (HS) Bourbon Cherry/Designer White (HLDW1) Charcoal/Black (SP) Charcoal/Designer White (SLDW1) Cognac/Black (COGNP) Cognac/Charcoal (COGNS) Cognac/Designer White (COGNLDW1) Designer White/Black (LDW1P) Designer White/Bourbon Cherry (LDWIH) Designer White/Charcoal (LDWIS) Designer White/Cognac (LDWICOGN) Designer White/Florence Walnut (LDWILFW1) Designer White/Harvest (LDWIC) Designer White/Kingswood Walnut (LDWILKI1) Designer White/Mahogany (LDWIN) Designer White/Mocha (LDWIMOCH) Designer White/Natural Maple (LDWID) Designer White/Pinnacle (LDWIPINC) Designer White/Sterling Ash (LDWILSA1)	Designer White/Shaker Cherry (LDWIF) Florence Walnut/Black (LFW1P) Florence Walnut/Charcoal (LFWIS) Florence Walnut/Designer White (LFWILDW1) Florence Walnut/Loft (LFWILOFT) Harvest/Black (CP) Harvest/Charcoal (CS) Harvest/Designer White (CLDW1) Kingswood Walnut/Black (LKIIP) Kingswood Walnut/Charcoal (LKIIS) Kingswood Walnut/Designer White (LKIILDW1) Kingswood Walnut/Loft (LKILOFT) Mahogany/Black (NP) Mahogany/Charcoal (NS) Mahogany/Designer White (NLDW1) Mocha/Black (MOCHP) Mocha/Charcoal (MOCHS) Mocha/Designer White (MOCHLDW1) Natural Maple/Black (DP) Natural Maple/Charcoal (DS) Natural Maple/Designer White (DLDW1) Pinnacle/Black (PINCP) Pinnacle/Charcoal (PINCS) Pinnacle/Designer White (PINCLDW1) Shaker Cherry/Black (FP) Shaker Cherry/Charcoal (FS) Shaker Cherry/Designer White (FLDW1) Sterling Ash/Black (LSA1P) Sterling Ash/Charcoal (LSAIS) Sterling Ash/Designer White (LSAILDW1)

NOTES:

- Durable material and construction make laminate occasional tables ideal for high traffic areas such as lobbies, reception rooms and lounges. Versatile design is also well suited to private offices.
- Tables accommodate lamps, magazines, telephones, plants, laptops and more.
- Coffee, Corner and End Tables feature top-over-apron styling with square corner detail, which complements many interiors and furniture designs.
- Tops are abrasion- and stain-resistant laminate over 1/8" thick solid core high-performance particleboard.
- For 10500 Series™ mobile tables, see page 266.
- See pages 265-288 for shared components.

HOW TO SPECIFY

<p>Select Model Number</p> <p>H 8 0 1 9 1 .</p> <p>H 8 0 1 9 1 .</p>	<p>Select Laminate</p> <p>See above</p> <p>N N</p> <p>L 6 N</p>
---	--



10500 Series™ Shared Components & Accessories

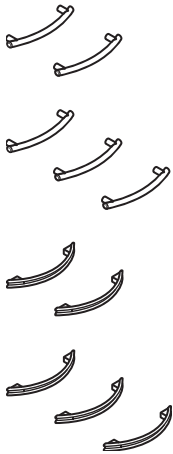

DESCRIPTION

Field Installable Drawer/Door Handle Kits

Sweep Black, 2-pack
Sweep Satin Nickel, 2-pack

Sweep Black, 3-pack
Sweep Satin Nickel, 3-pack

Crescent Black, 2-pack
Crescent Satin Nickel, 2-pack

Crescent Black, 3-pack
Crescent Satin Nickel, 3-pack

MODEL

SHIP WEIGHT

CUBE

LIST PRICE

HSWEEPA2	0.4 Ⓢ	0.3	\$43
HSWEEPC2	0.4 Ⓢ	0.3	\$43
HSWEEPA3	0.5 Ⓢ	0.3	\$56
HSWEEPC3	0.5 Ⓢ	0.3	\$56
HCRESCENTA2	0.4 Ⓢ	0.3	\$43
HCRESCENTC2	0.4 Ⓢ	0.3	\$43
HCRESCENTA3	0.5 Ⓢ	0.3	\$56
HCRESCENTC3	0.5 Ⓢ	0.3	\$56

NOTES: Handles are for purchase and field installation on 10500 or 10700 Series™ desks, credenzas, returns, and lateral files, as well as for the modular pedestals used with 10700 and 10500.

Applications include:

- box/file and file/file pedestals = one 2-pack per pedestal
- box/box/file and pencil/media/file pedestals = one 3-pack per pedestal
- two drawer lateral file = two 2-packs per unit
- four drawer lateral file = four 2-packs per unit

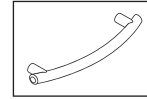

Sweep Handle

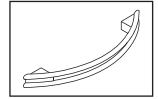

Crescent Handle

The hole spacing for the Sweep and Crescent handles is 96mm (approx. 3 3/4"). Important note: effective January 1, 2007, the holes used for the black drawer/door handle that comes standard on several HON 10500 and 10700 Series™ products, including mobile pedestals, storage cabinet with doors, storage/file cabinet, storage cabinet/lateral file, personal wardrobe/storage cabinets, and personal storage towers, will accept the Sweep and Crescent handles. Units manufactured prior to January 1, 2007, have 64mm (approx. 2 1/2") hole spacing and will not accept the Sweep and Crescent handles. Instructions include mounting hardware and paper template.

! Must be ordered with a configurable end product. If ordered separately, not on GSA contract.

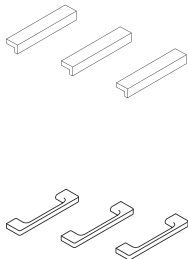

Field Installable Drawer/Door Handle Kits

Linear, Black, 2-pack
Linear, Matte Chrome, 2-pack

Linear, Black, 3-pack
Linear, Matte Chrome, 3-pack

Specify Linear handles in black to coordinate with 10500 Series™ models that ship standard with a decorative handle, such as mobile pedestals, storage cabinets and wardrobes.

HLINEARA2	0.4 Ⓢ	0.3	\$56
HLINEARC2	0.4 Ⓢ	0.3	\$56
HLINEARA3	0.5 Ⓢ	0.3	\$64
HLINEARC3	0.5 Ⓢ	0.3	\$64
HARCHA2	0.4 Ⓢ	0.3	\$56
HARCHC2	0.4 Ⓢ	0.3	\$56
HARCHA3	0.5 Ⓢ	0.3	\$64
HARCHC3	0.5 Ⓢ	0.3	\$64

NOTES: Handles are for purchase and field installation on 10500 or 10700 Series™ desks, credenzas, returns, lateral files and modular pedestals. Instructions include mounting hardware and paper template for drilling holes.

Applications include:

- box/file and file/file pedestals = one 2-pack per pedestal
- box/box/file and pencil/media/file pedestals = one 3-pack per pedestal
- two drawer lateral file = two 2-packs per unit
- four drawer lateral file = four 2-packs per unit

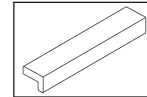

Linear Handle

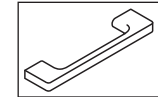

Arch Handle

The Linear and Arch handles can be attached using 96mm (approx. 3 3/4") or 128mm (approx. 5") hole spacing. Important note: effective January 1, 2007, the holes used for the black drawer/door handle that comes standard on several HON 10500 and 10700 Series™ products, including mobile pedestals, storage cabinet with doors, storage/file cabinet, storage cabinet/lateral file, personal wardrobe/storage cabinets, and personal storage towers, will accept the Linear and Arch handles. Units manufactured prior to January 1, 2007, have 64mm (approx. 2 1/2") hole spacing and will not accept the Linear and Arch handles.

! Must be ordered with a configurable end product. If ordered separately, not on GSA contract.

NOTES:

- Field Installable Drawer/Door Handle Kits for use on 10500 Series™ desks, credenzas, returns and lateral files.
- A metal template is available to facilitate field installation of the Linear, Arch, Sweep and Crescent decorative handles on 10500 and 10700 Series™ drawer fronts; order model SPLH-SYST-DRKNB.M263164.
- See pages 265-288 for shared components.

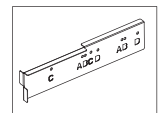

Metal Template

HOW TO SPECIFY

Select Model Number

H S W E E P A 2

10500 SERIES™

Shared Components & Accessories

OPEN MARKET EXCEPT AS NOTED

ABI

Icon Legend on page 19

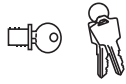

SIN 33721

**DESCRIPTION**
Black Removable Lock Core Kit
Satin Removable Lock Core Kit

- Specify quantity of each key number from 101E-225E.
- Includes: 1-core, 2-keys, 1-core removal tool, and instructions.

NOTES: Lock with a removable cylinder that can be interchanged as needed; allows users to access all furniture pieces in an office with a single key for convenience and security. Makes re-keying quick and easy. For use in all 10500 Series™ product lock cores, except the stack-on and wall mounted storage "K" models. For the latter use model HF27B or HF27S, listed below.

MODEL**SHIP WEIGHT****CUBE****LIST PRICE****HF23B**

0.1 Ⓞ

0.1

\$32**HF23S**

0.1 Ⓞ

0.1

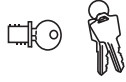
\$40**Removable Lock Core Kit**Black
Satin**HF27B**

0.2

0.02

\$32**HF27S**

0.2

0.02

\$32

- For stack-on and wall mounted storage laminate models (with locks) in 10500, 10700, Valido, Voi, Concinnity, and 94000 Series.
- Specify quantity of each key number from 101E to 225E.
- Includes: 1-core, 2-keys, 1-core removal tool, and instructions.

NOTES: If key number isn't specified, number will be at random.

NOTES:

- See pages 265-288 for shared components.
- For master key, see model HF22 on page 853.

HOW TO ORDER CORE REMOVABLE LOCK KITS:

Specify: Model Number.X
Key Number

Examples: HF23S.X121E
HF23S.X (Key number not specified)

NOTES: Key orders without numbers specified will be keyed at random.
Numbers 101E-225E are available.

SAMPLE ORDER:

Quantity	Model	Key Code
4	HF23B.	X121E

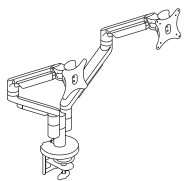
**DESCRIPTION****Dual Dynamic Monitor Arm**

- 150° of rotation at base with optional 360° rotation.
- Arms extend 22" and retract up to 3".
- Monitor mount rotates 180° and tilts +/-30°.
- Monitor can be rotated from landscape to portrait position.

! Arms hold monitors from 6.2-18 lbs. Optional counterweight HPACW available to support monitors as low as 5 lbs. (see page 827).

MODEL**SHIP WEIGHT****CUBE****LIST PRICE****HMASD**

17.0 Ⓞ

1.1

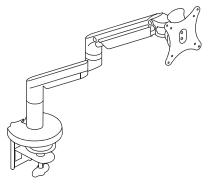
\$750**Single Dynamic Monitor Arm**

- 180° of rotation at base with optional 360° rotation.
- Arms extend 22" and retract up to 3".
- Monitor mount rotates 180° and tilts +/-30°.
- Monitor can be rotated from landscape to portrait position.

! Arms hold monitors from 6.2-18 lbs. Optional counterweight HPACW available to support monitors as low as 5 lbs. (see page 827).

HMAST

11.5 Ⓞ

0.8







\$390**HOW TO SPECIFY**
**Select
Model Number**
**Select
Finish**
Specify for models HMASD and HMAST only
SVR Silver
BLK Black

H M A S D
S V R

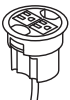

Icon Legend on page 19

10500 Series™ Shared Components & Accessories

	DESCRIPTION	MODEL	SHIP WEIGHT	CUBE	LIST PRICE
 SIN 33721	<p>Field Installable Grommet</p> <ul style="list-style-type: none"> Intended for use in tops and end panels to route/hide cords and in modesty panels to facilitate reaching wall electrical outlets. Grommet is field installable. Grommet shape is round. Includes grommet cap and sleeve. Grommet cap measures 3" diameter and includes a 3/4" diameter cord access hole. Grommet sleeve measures 2 1/2" O.D. x 3/4" thick. Includes instructions to locate grommet position for desks, credenzas, returns and bridges. <p>NOTES: For additional information see page 848.</p> <ul style="list-style-type: none"> ❗ Black Finish ❗ Requires a 2 1/2" diameter hole saw and drill for installation (not included). 	HFLDGRMT	0.1 Ⓢ	0.01	\$32
 SIN 33721	<p>Field Installable Grommet</p> <ul style="list-style-type: none"> Intended for use in tops and end panels to route/hide cords and in modesty panels to facilitate reaching wall electrical outlets. Grommet is field installable. Grommet shape is round. Includes grommet cap and sleeve. Grommet outside dimensions measure 3 1/2" diameter and includes two cord access holes. Grommet sleeve measures 3" O.D. x 1" thick. Includes instructions to locate grommet position for desks, credenzas, returns and bridges. <p>NOTES: For additional information see page 848.</p> <ul style="list-style-type: none"> ❗ Black Finish ❗ Requires a 3" diameter hole saw and drill for installation (not included). 	HFLDGRMT3	0.1 Ⓢ	0.3	\$32
	<p>Power Hub, 3" Grommet Mount, 6' Cord</p> <ul style="list-style-type: none"> Brings the ease of plug-and-play to the desktop. Fits in 3" round grommet holes in 10500 Series™ desks, credenzas and returns; not compatible with 10500 Series™ 2 1/2" round grommets. Two grounded AC power outlets. Two cord pass-through holes in cap. Includes 6' cord with three-prong plug. For field installation. UL Listed. <p>NOTES: For additional information see page 848.</p> <ul style="list-style-type: none"> ❗ Available in Black only (no color designation – Specify: HGRMTAC.X). 	HGRMTAC	1.3	0.2	\$111
 	<p>3" Round Power Grommet – 2 Outlets, 10' Cord</p> <ul style="list-style-type: none"> Includes 10' cord with three-prong plug. Fits in 3" round grommet holes on the following product lines: Coordinate, Huddle, Motivate, all laminate and veneer casegoods series, and Systems Worksurfaces. Two grounded AC power outlets. Field installed with Plug-and-play ease. <p>NOTES: Power Modules will also work with standing-height applications for 10500 Series™ and Voi® desks. Optional Memory Control allows preset worksurface heights for consistency. Ships separately. Dynamic load capacity when worksurface is moving is 300 lbs.</p> <ul style="list-style-type: none"> ❗ Available in black finish only, no specification needed. 	HGRMTAC2	1.5	0.2	\$148
	<p>Power/USB Hub, 3" Grommet Mount</p> <ul style="list-style-type: none"> Brings the ease of plug-and-play to the desktop. Fits in 3" round grommet holes in 10500 Series™ desks, credenzas and returns; not compatible with 10500 Series™ 2 1/2" round grommets. One grounded AC power outlet with 2 USB ports. Two cord pass-through holes in cap. Includes 6' cord with three-prong plug. For field installation. UL Listed. <p>NOTES: For additional information see page 848.</p> <ul style="list-style-type: none"> ❗ Available in black only (no color designation so use .X – Specify: HGRMTUSB2.X). 	HGRMTUSB2	1.3 Ⓢ	0.02	\$224

NOTES:

- See pages 265-288 for shared components.

HOW TO SPECIFY

Select Model Number

H	F	L	D	G	R	M	T
---	---	---	---	---	---	---	---

10500 SERIES™

Shared Components & Accessories

GSA SIN AS NOTED

ABI

Icon Legend on page 19



SIN 33721

DESCRIPTION

Articulating Desk Lamp
Articulating Desk Lamp w/ Occupancy Sensor

NOTES: For additional information see page 841.

! Silver finish only, no specification needed.

MODEL

HLED1
HLED10C

SHIP WEIGHT

1.2 Ⓢ
 1.2 Ⓢ

CUBE

6.5
 6.5

LIST PRICE

\$402
\$490



SIN 33721

Task Desk Lamp

NOTES: For additional information see page 841.

! Brushed nickel finish only, no specification needed.

HLED2

0.7 Ⓢ

3.0

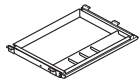
\$348

OPEN MARKET

Polymer Center Drawer

- Color: Black.
- Material: ABS.
- Opening Requirements: 23"W x 16¼"D x 2"H.
- Retracts on 16" ball-bearing slides.
- Can be used on worksurfaces with Coordinate™ Height Adjustable Bases as long as it is attached with spacer model HKBS.
- Can store up to 25 lbs.

NOTES: For additional information see page 833.

! Black finish only, no specification needed.

HCD1

7.0

0.5

\$108

OPEN MARKET

CPU Holder

- Vertically mounts to underside of worksurface.
- 360° swivel.
- Supports up to 55 lbs.
- Height adjustable from 16" to 22" below worksurface.
- Width adjustable to accept units from 3¼" to 6".

! Silver finish only, no specification needed.

HCPU *

16.0 Ⓢ

0.5

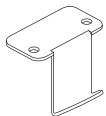
\$259

OPEN MARKET

Back Pack Hook (10 per carton)

12"W x 14½"D x 1½"H

NOTES: Assembly; attaches to bottom of desk with (2) screws, included. For additional information see page 846.

! Available in Platinum Metallic finish only, no specification needed.

HCLA65

10.0 Ⓢ

0.1

\$94

OPEN MARKET

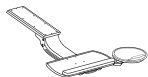
DESCRIPTION**MODEL****SHIP WEIGHT CUBE****LIST PRICE BY PAINT GRADE**

Refer to pages 829-830 for additional product information

SIN 33721



Sit to Stand Arm with Convertible Keyboard Platform

H2516 OPEN MARKET *

17 Ⓢ

1.6

\$618

Articulating Arm with Convertible Keyboard Platform

H2107 OPEN MARKET *

16 Ⓢ

1.3

\$529

Articulating Arm with Keyboard Platform

H1706 OPEN MARKET *

16 Ⓢ

1.4

\$493

Slide-Away Keyboard Platform (Specify: Laminate)

H4022

10 Ⓢ

0.6

\$213

Extended Tray Slide-Away Keyboard Platform
 (Specify: Laminate)

HE4022

12 Ⓢ

0.7

\$302

Metal Keyboard and Mouse Tray (Specify paint)

H4028 OPEN MARKET

11 Ⓢ

1.5

\$153**\$163**

Metal Keyboard Tray (Specify paint)

H4029 OPEN MARKET

11 Ⓢ

1.5

\$138**\$148**

NOTES: For additional information see pages 829-830.

NOTES:

- See pages 265-288 for shared components.

* De-emphasized.

HOW TO SPECIFY

Select
Model Number

HLED1

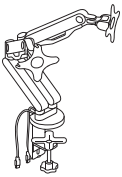
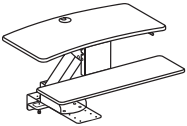
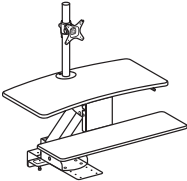
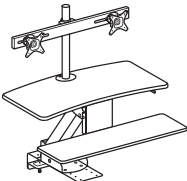
	DESCRIPTION	MODEL	SHIP WEIGHT	CUBE	LIST PRICE
	<p>Coordinate™ Portable Desktop Riser 31"D x 5"-16½"H x 35"W</p> <p>NOTES: Available in Black (BLK) or White (WHT) finish. Desktop riser dimensions (without keyboard tray): 22"D x 5"-16½"H x 35"W. Keyboard tray dimensions: 9"D x 30"W. Max loading capacity is 33 lbs for the desktop riser surface and 4 lbs for the keyboard tray. Easily transition from seated to standing positions throughout the workday. Sits atop an existing desk to create sit-to-stand functionality by raising the computer. Includes keyboard tray and surface for computer monitors. HON 5-Year Limited Warranty.</p> <p>ⓘ Not intended for use on mobile workstations.</p>	HBXRISER	54.0	4.1	\$619
	<p>Dual Monitor Arm with 2 USB Ports</p> <p>NOTES: Easy adjustment. Height adjusts to 17" tall. Monitor tilt and swivel capability. Enclosed cable management. Grommet or desktop mounting. Clean appearance. In some applications the Monitor Arms may extend 12 or more inches into the worksurface. For additional information see page 825. HON 5-Year Limited Warranty.</p> <p>ⓘ No specification needed.</p>	HBDMAUSB	41.9	2.6	\$441
	<p>Coordinate™ Mounted Desktop Riser</p> <p>NOTES: Does not include a monitor arm and is suitable for laptops and/or monitors on their original stands.</p> <p>ⓘ No specification needed.</p>	HS1100	60.0 ⓘ	3.2	\$664
	<p>Coordinate™ Mounted Desktop Riser with Single Monitor Arm</p> <p>NOTES: Includes a monitor arm for a single monitor.</p> <p>ⓘ No specification needed.</p>	HS1101	62.0 ⓘ	3.2	\$777
	<p>Coordinate™ Mounted Desktop Riser with Dual Monitor Arm</p> <p>NOTES: Includes a monitor arm for dual monitors.</p> <p>ⓘ No specification needed.</p>	HS1102	63.0 ⓘ	3.2	\$883

NOTES FOR HS1100, HS1101, HS1102:

- These products are designed to allow the user to transition from seating position to standing position throughout the workday.
- Gas-assist lever-operated mechanism with positive stop.
- Clamp mount compatible with worksurfaces depths of 20"-30". 20" is for systems only.
- Clamp requires 3.5" of clearance along back edge of worksurface.
- Black seamless worksurfaces.
- Silver powder coated metal components.
- Lowers below worksurface level on 24" and 30"D worksurfaces.
- All models contain a large primary worksurface and a smaller keyboard / mouse surface.
- Beveled edges for sleek appearance and comfort while typing.
- Monitor arms include height, width, and swivel adjustment.
- For additional information see page 838.

- Not for use under overhead storage, with flush mounted modesty panels, or worksurfaces thinner than 1".

ⓘ Not recommended for use on mobile (castered) worksurfaces.

MOUNTING AND COMPATIBILITY FOR HS1100, HS1101, HS1102:

- This product is intended to be installed on commercial-grade worksurfaces in good condition.
- Compatible with freestanding worksurfaces 24"-30"D or panel-supported worksurfaces 24"-30"D.
- Not for use on mobile worksurfaces.

Clamp Mount

Use when 3.5" minimum overhang is available

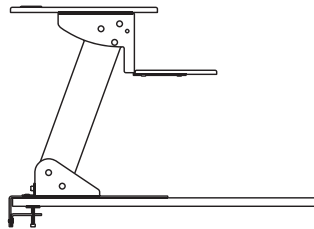

Screw Mount

Use when no overhang is available. Worksurface must be minimum 1" thick.

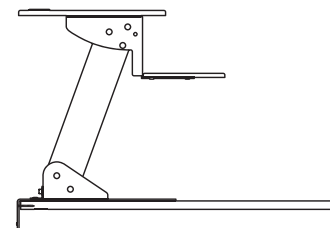

HOW TO SPECIFY

<p>Select Model Number</p> <p>HBXRISER.</p>	<p>Select Finish</p> <p>BLK Black WHT White</p> <p>BLK</p>
---	--



10500 SERIES™

Accessories

OPEN MARKET

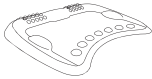
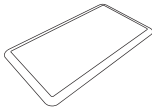
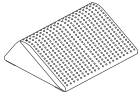

Icon Legend on page 19

	DESCRIPTION	MODEL	SHIP WEIGHT	CUBE	LIST PRICE
	Rectangle Wobble Board — Anti-Fatigue Mat 18"D x 3"H x 22½"W ⓘ Available in Black (T) finish ONLY. Recommended weight capacity not to exceed 250 pounds. HON 5-Year Limited Warranty. SPECIFYING EXAMPLE: HVL981.T	HVL981	10.0 Ⓢ	0.9	\$120
	Round Wobble Board — Anti-Fatigue Mat 18½"D x 2½"H x 18½"W ⓘ Available in Black (T) finish ONLY. Recommended weight capacity not to exceed 250 pounds. HON 5-Year Limited Warranty. SPECIFYING EXAMPLE: HVL982.T	HVL982	5.8 Ⓢ	0.6	\$102
	Ergonomic Anti-Fatigue Mat 25"D x 2¾"H x 29⅞"W ⓘ Available in Black ONLY. No specification needed. SPECIFYING EXAMPLE: HBEAFM1	HBEAFM1	7.0	1.4	\$219
	Rectangle Anti-Fatigue Mat 20"D x ¾"H x 36"W ⓘ Available in Black ONLY. No specification needed. SPECIFYING EXAMPLE: HBAFM2036	HBAFM2036	5.4	0.4	\$100
	Footrest — Anti-Slip Cover 13¾"D x 5½"H x 16"W ⓘ Available in Black (T) finish ONLY. Recommended weight capacity not to exceed 250 pounds. HON 5-Year Limited Warranty. SPECIFYING EXAMPLE: HVL991.T	HVL991	7.0 Ⓢ	0.9	\$82

HOW TO SPECIFY

Select
Model Number

H V L 9 8 1 .

Select
Finish

T Black

T

10700 SERIES™



10700 Series™ Teaming Workstations shown with Ignition® and Flock® Seating.

10700 SERIES™

Talk about a high achiever! The versatile 10700 Series offers a wide selection of layout configurations — making it easy to get the clean, cohesive look your office needs. Designed to withstand frequent moving and reconfiguration, the 10700 Series boasts contract grade high-pressure laminate and a durable inner-frame construction. Whatever the look you go for, this all-around performer is a smart choice.

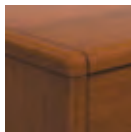

FEATURES

- Contoured, solid wood accents and waterfall-shaped edges combine form and function for lasting comfort.
- Make the most of both large and small spaces with flexible storage options that work well together.
- With a variety of mixed materials to choose from, you can customize your look to perfectly match your aesthetic.
- Available in eight woodgrain patterns, our laminate desks are the definition of scratch-, spill- and stain-resistant durability.

10700 SERIES™ ORDERING INFORMATION

LAMINATE FINISHES AVAILABILITY

L1 LAMINATES CODES

Woodgrain

- ◆ Bourbon Cherry HH
- ◆ Cognac **COGNCOGN**
- ◆ Harvest CC
- ◆ Mahogany NN
- ◆ Mocha **MOCHMOCH**
- ◆ Natural Maple DD
- ◆ Pinnacle **PINCPINC**
- ◆ Shaker Cherry FF

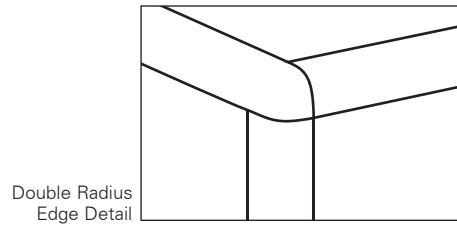

◆◆◆ For lead time information see page 19.

10700 SERIES™

Typicals



Icon Legend on page 19

Components used are listed on pages 300-321. Order components individually. Other configurations are possible, including various sizes of some components.

QTY	DESCRIPTION	MODEL	LIST PRICE	PRICE EXTENSION
1	Double Pedestal Desk – 2/2 60"W x 30"D x 29½"H	H10771	\$1,367	\$1,367
1	Credenza with Kneespace – 2/0/2 60"W x 24"D x 29½"H	H10765	\$1,304	\$1,304
TOTAL:			\$2,671	

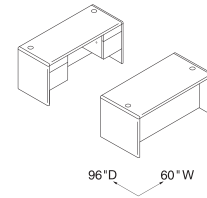

DESK WORKSTATION
60"W x 96"D

QTY	DESCRIPTION	MODEL	LIST PRICE	PRICE EXTENSION
1	Corner Unit 24" x 36" x 36" x 24" x 29½"H	H107811	\$1,196	\$1,196
1	Return, Right – B/F 48"W x 24"D x 29½"H	H10715R	\$905	\$905
1	Return, Left – B/F 48"W x 24"D x 29½"H	H10716L	\$905	\$905
1	Stack-on Storage 44⅝"W x 14⅝"D x 37⅞"H	H107313	\$1,067	\$1,067
TOTAL:			\$4,073	

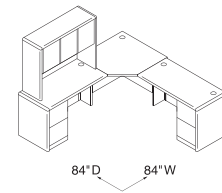

CORNER "L" WORKSTATION
84"W x 84"D

QTY	DESCRIPTION	MODEL	LIST PRICE	PRICE EXTENSION
1	Single Pedestal Desk, Left – B/F 72"W x 36"D x 29½"H	H10786L	\$1,346	\$1,346
1	Bridge 47"W x 24"D x 29½"H	H10770	\$409	\$409
1	Credenza with Lateral, Right 72"W x 24"D x 29½"H	H10747R	\$1,626	\$1,626
1	Stack-on Storage 68⅝"W x 14⅝"D x 37⅞"H	H10734	\$1,211	\$1,211
TOTAL:			\$4,592	

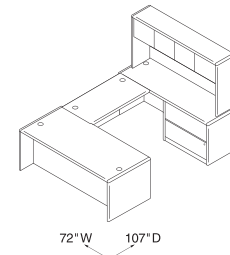

DESK "U" WORKSTATION – RIGHT
72"W x 107"D

QTY	DESCRIPTION	MODEL	LIST PRICE	PRICE EXTENSION
1	Double Pedestal Desk – 3/2 72"W x 36"D x 29½"H	H10799	\$2,081	\$2,081
1	Credenza with Storage 72"W x 24"D x 29½"H	H10742	\$2,081	\$2,081
TOTAL:			\$4,162	

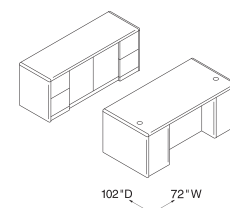

**DESK WORKSTATION WITH
STORAGE CRENZA**
72"W x 102"D



Icon Legend on page 19

10700 SERIES™ Typicals

Components used are listed on pages 300-321. Order components individually. Other configurations are possible, including various sizes of some components.

QTY	DESCRIPTION	MODEL	LIST PRICE	PRICE EXTENSION
1	Double Pedestal Desk – 3/2 72"W x 36"D x 29½"H	H10799	\$2,081	\$2,081
1	Credenza with Kneespace – 2/0/2 72"W x 24"D x 29½"H	H10741	\$1,796	\$1,796
1	Stack-on Storage 68⅝"W x 14⅝"D x 37⅞"H	H10734	\$1,211	\$1,211
1	Wardrobe/Storage Cabinet, Right 18"W x 24"D x 66⅝"H	H107295R	\$1,839	\$1,839
TOTAL:			\$6,927	

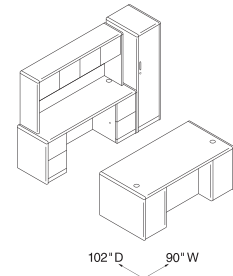

DESK WORKSTATION
90"W x 102"D

QTY	DESCRIPTION	MODEL	LIST PRICE	PRICE EXTENSION
1	Peninsula 72"W x 36"D x 29½"H	H10721	\$1,329	\$1,329
1	Return, Left – F/F 42"W x 24"D x 29½"H	H107192L	\$1,092	\$1,092
1	Stack-on Storage 74⅝"W x 14⅝"D x 37⅞"H	H107318	\$1,329	\$1,329
TOTAL:			\$3,750	

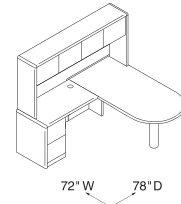

PENINSULA "L" WORKSTATION – LEFT
72"W x 78"D

QTY	DESCRIPTION	MODEL	LIST PRICE	PRICE EXTENSION
1	Single Pedestal Desk, Right – B/B/F 66"W x 30"D x 29½"H	H10701R	\$1,651	\$1,651
1	Return, Left – F/F 48"W x 24"D x 29½"H	H10712L	\$1,105	\$1,105
1	Stack-on Storage 74⅝"W x 14⅝"D x 37⅞"H	H107318	\$1,329	\$1,329
1	2-Drawer Lateral File 36"W x 24"D x 29½"H	H107690	\$1,206	\$1,206
TOTAL:			\$5,291	

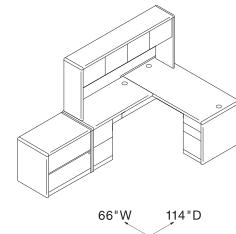

DESK "L" WORKSTATION – LEFT
66"W x 114"D

QTY	DESCRIPTION	MODEL	LIST PRICE	PRICE EXTENSION
1	Peninsula 72"W x 36"D x 29½"H	H10721	\$1,329	\$1,329
1	Bridge 47"W x 24"D x 29½"H	H10770	\$409	\$409
1	Credenza Shell with Full Modesty Panel 72"W x 24"D x 29½"H	H107817	\$904	\$904
1	Multi File Pedestal 36"W x 20"D x 28"H	H10505	\$1,249	\$1,249
1	Stack-on Storage 68⅝"W x 14⅝"D x 37⅞"H	H10734	\$1,211	\$1,211
TOTAL:			\$5,102	

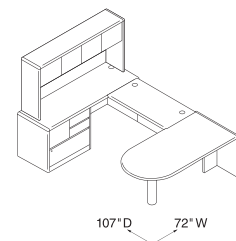

PENINSULA "U" WORKSTATION – LEFT
72"W x 107"D

10700 SERIES™

Typicals



Icon Legend on page 19

Components used are listed on pages 300-321. Order components individually. Other configurations are possible, including various sizes of some components.

QTY	DESCRIPTION	MODEL	LIST PRICE	PRICE EXTENSION
1	Single Pedestal Desk, Left - B/B/F 72"W x 36"D x 29½"H	H10788L	\$1,796	\$1,796
1	Bridge 47"W x 24"D x 29½"H	H10770	\$409	\$409
1	Single Pedestal Credenza, Right - F/F 72"W x 24"D x 29½"H	H10707R	\$1,469	\$1,469
1	Stack-on Storage 68⅝"W x 14⅝"D x 37⅞"H	H10734	\$1,211	\$1,211
1	Wardrobe/Storage Cabinet, Right 18"W x 24"D x 66⅝"H	H107295R	\$1,839	\$1,839
TOTAL:			\$6,724	

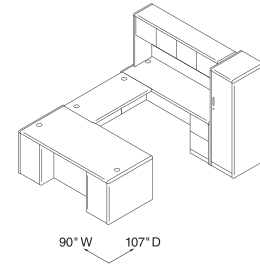

DESK "U" WORKSTATION - RIGHT

90"W x 107"D

QTY	DESCRIPTION	MODEL	LIST PRICE	PRICE EXTENSION
1	Return Shell, Left 36"W x 24"D x 29½"H	H107802L	\$608	\$608
1	Corner Unit 24" x 36" x 36" x 24" x 29½"H	H107811	\$1,196	\$1,196
1	Return Shell, Right 36"W x 24"D x 29½"H	H107801R	\$608	\$608
1	Stack-on Storage 68⅝"W x 14⅝"D x 37⅞"H	H10734	\$1,211	\$1,211
1	Mobile Pedestal - B/B/F 15¾"W x 22¾"D x 28"H	H105102	\$854	\$854
1	Mobile Pedestal - F/F 15¾"W x 22¾"D x 28"H	H105104	\$854	\$854
TOTAL:			\$5,331	

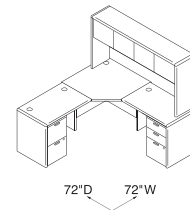

CORNER 6' X 6' WORKSTATION

72"W x 72"D

QTY	DESCRIPTION	MODEL	LIST PRICE	PRICE EXTENSION
1	Desk Shell 66"W x 30"D x 29½"H	H107826	\$968	\$968
1	Credenza Shell 66"W x 24"D x 29½"H	H107816	\$843	\$843
2	Mobile Pedestal - B/B/F 15¾"W x 22¾"D x 28"H	H105102	\$854	\$1,708
2	Mobile Pedestal - F/F 15¾"W x 22¾"D x 28"H	H105104	\$854	\$1,708
TOTAL:			\$5,227	

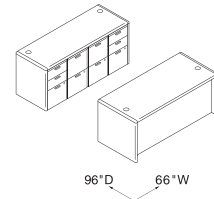

MODULAR DESK AND CREDEZA

66"W x 96"D

QTY	DESCRIPTION	MODEL	LIST PRICE	PRICE EXTENSION
1	Peninsula 66"W x 30"D x 29½"H	H10722	\$1,161	\$1,161
1	Bridge 42"W x 24"D x 29½"H	H10760	\$394	\$394
1	Corner Unit 24" x 36" x 36" x 24" x 29½"H	H107811	\$1,196	\$1,196
1	Return Shell, Right 42"W x 24"D x 29½"H	H107803R	\$608	\$608
1	Mobile Pedestal - B/B/F 15¾"W x 22¾"D x 28"H	H105102	\$854	\$854
1	Mobile Pedestal - F/F 15¾"W x 22¾"D x 28"H	H105104	\$854	\$854
1	Stack-on Storage 74⅝"W x 14⅝"D x 37⅞"H	H107318	\$1,329	\$1,329
TOTAL:			\$6,396	

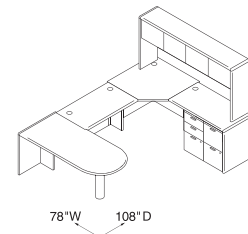

**PENINSULA "U" WITH
MODULAR COMPONENTS**

78"W x 108"D



Icon Legend on page 19

10700 SERIES™ Bundles Typicals

Mahogany H107LL7284N

QTY	DESCRIPTION	MODEL	LIST PRICE	PRICE EXTENSION
1	Left Pedestal Desk	H10786L	\$1,346	\$1,346
1	Right Return	H10715R	\$905	\$905
TOTAL:			\$2,251	

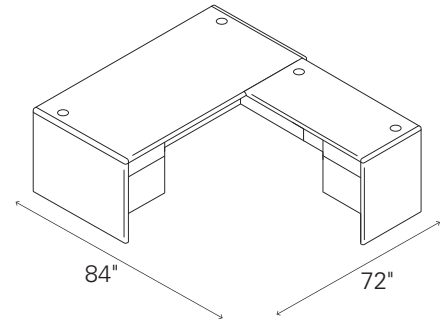

L-STATION (LEFT DESK, RIGHT RETURN)

Mahogany H107LR7284N

QTY	DESCRIPTION	MODEL	LIST PRICE	PRICE EXTENSION
1	Right Pedestal Desk	H10785R	\$1,346	\$1,346
1	Left Return	H10716L	\$905	\$905
TOTAL:			\$2,251	

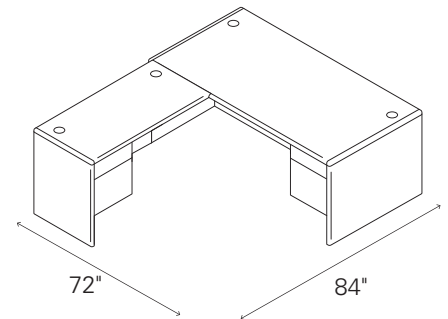

L-STATION (RIGHT DESK, LEFT RETURN)

Mahogany H107UL72108N

QTY	DESCRIPTION	MODEL	LIST PRICE	PRICE EXTENSION
1	Left Pedestal Desk	H10786L	\$1,346	\$1,346
1	Right Pedestal Credenza	H10745R	\$1,181	\$1,181
1	Bridge	H10770	\$409	\$409
TOTAL:			\$2,936	

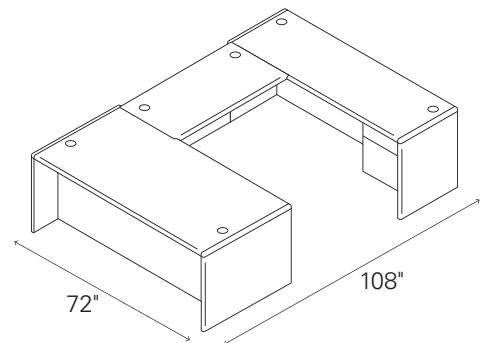

U-STATION (LEFT DESK, RIGHT CREDENZA)

10700 SERIES™

Bundles Typicals



Icon Legend on page 19

Mahogany
H107UR72108N

QTY	DESCRIPTION	MODEL	LIST PRICE	PRICE EXTENSION
1	Right Pedestal Desk	H10785R	\$1,346	\$1,346
1	Left Pedestal Credenza	H10746L	\$1,181	\$1,181
1	Bridge	H10770	\$409	\$409
TOTAL:			\$2,936	

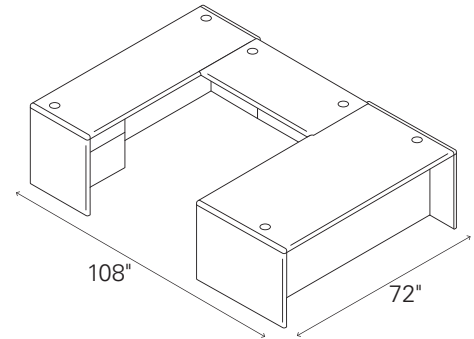

U-STATION (RIGHT DESK, LEFT CREDENZA)

Mahogany
H107LLH7284N

QTY	DESCRIPTION	MODEL	LIST PRICE	PRICE EXTENSION
1	Left Pedestal Desk	H10786L	\$1,346	\$1,346
1	Right Return	H10715R	\$905	\$905
1	Stack-on Storage	H107313	\$1,067	\$1,067
TOTAL:			\$3,318	

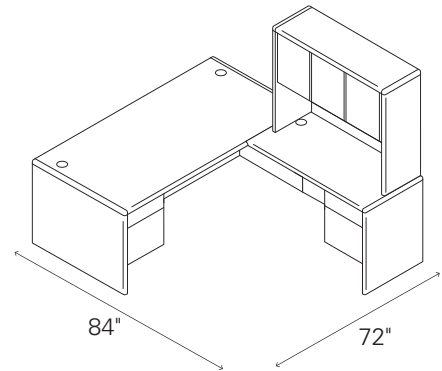

**L-STATION WITH STACK-ON STORAGE
(LEFT DESK, RIGHT RETURN)**

Mahogany
H107LRH7284N

QTY	DESCRIPTION	MODEL	LIST PRICE	PRICE EXTENSION
1	Right Pedestal Desk	H10785R	\$1,346	\$1,346
1	Left Return	H10716L	\$905	\$905
1	Stack-on Storage	H107313	\$1,067	\$1,067
TOTAL:			\$3,318	

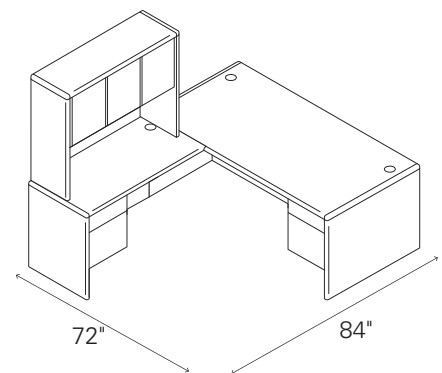

**L-STATION WITH STACK-ON STORAGE
(RIGHT DESK, LEFT RETURN)**



Icon Legend on page 19

10700 SERIES™ Bundles Typicals

DESKS

Mahogany
H107ULH72108N

QTY	DESCRIPTION	MODEL	LIST PRICE	PRICE EXTENSION
1	Left Pedestal Desk	H10786L	\$1,346	\$1,346
1	Right Pedestal Credenza	H10745R	\$1,181	\$1,181
1	Bridge	H10770	\$409	\$409
1	Stack-on Storage	H10734	\$1,211	\$1,211
TOTAL:			\$4,147	\$4,147

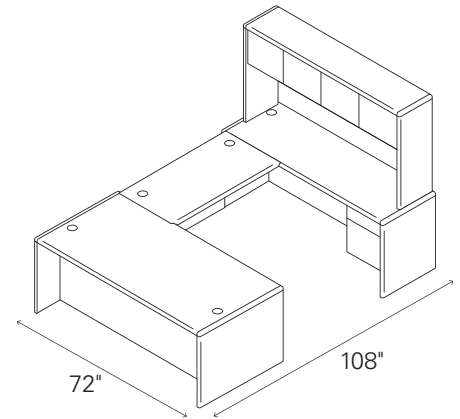

**U-STATION WITH STACK-ON STORAGE
(LEFT DESK, RIGHT CREDENZA)**

Mahogany
H107URH72108N

QTY	DESCRIPTION	MODEL	LIST PRICE	PRICE EXTENSION
1	Right Pedestal Desk	H10785R	\$1,346	\$1,346
1	Left Pedestal Credenza	H10746L	\$1,181	\$1,181
1	Bridge	H10770	\$409	\$409
1	Stack-on Storage	H10734	\$1,211	\$1,211
TOTAL:			\$4,147	\$4,147

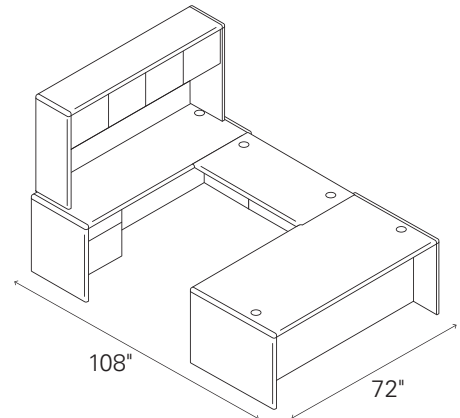

**U-STATION WITH STACK-ON STORAGE
(RIGHT DESK, LEFT CREDENZA)**

10700 SERIES™

Laminate Modular Components

GSA SIN 33721



Icon Legend on page 19

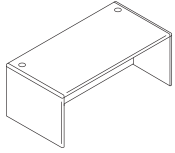

DESCRIPTION	INSIDE DIMENSIONS	FULL WIDTH OVERHANG	MODEL	SHIP WEIGHT	CUBE	LIST PRICE
Desk Shell w/Full Modesty Panel						
72"W x 36"D x 29½"H	69½"W x 24⅝"D	10½"	H107827	213	7.0	\$1094
72"W x 30"D x 29½"H	69½"W x 24⅝"D	4½"	H107829	167	4.7	\$972
66"W x 30"D x 29½"H	63½"W x 24⅝"D	4½"	H107826	175	5.5	\$968
60"W x 30"D x 29½"H	57½"W x 24⅝"D	4½"	H107825	164	5.0	\$838
48"W x 30"D x 29½"H	45½"W x 24⅝"D	4½"	H107824	143	5.0	\$814

NOTES: Can be used freestanding or connected to a 42"W return shell to achieve a space efficient 6' x 6' L-shaped workstation layout. Accepts stack-on storage models H10734, H10734K or H10734G. See page 320 for optional center drawers.

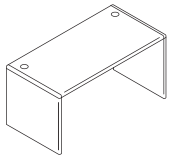

Desk Shell w/10" Modesty Panel						
60"W x 30"D x 29½"H	57½"W x 24⅝"D	4½"	H107825X	161	4.0	\$838

NOTES: Makes reaching wall electrical outlets quick and easy. Provides more than 18" of clearance. Can be used freestanding or connected to a 30"W return shell to achieve a compact 5' x 5' L-shaped workstation layout. Accepts stack-on storage models H10732, H10732K. See page 320 for optional center drawers.

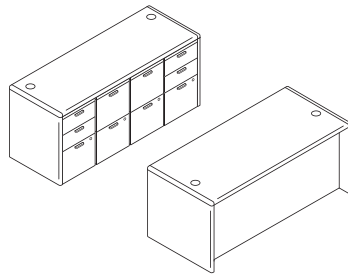

96"D 66"W

1 – H107826
1 – H107816
2 – H105102
2 – H105104

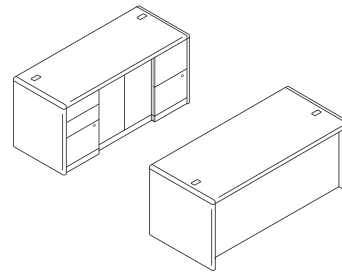

96"D 60"W

1 – H107825
1 – H107815
1 – H10508
1 – H10504
1 – H10502

! All 10700 Series™ grommets on desk, credenza, credenza shell, return, return shell, bridge and corner unit worksurfaces changed from rectangle-shaped to round, effective November, 2011.

NOTES:

- Desk, credenza, and return shells, combined with a variety of under-the-worksurface storage solutions, maximize office layout flexibility. Products can be reconfigured quickly and easily when user preferences or space needs change.
- Worksurfaces and end panels feature contract-grade scratch, stain and spill resistant laminate over durable 1⅛" solid core high-performance particleboard; resists warping.
- Contoured hardwood trim; stained to match laminate.
- User friendly waterfall-shaped edges and round corners.
- 3" round cord management grommets, for routing and hiding wires and cables, are located in the tops of desk, credenza, and return shells. Grommets also serve as anchor points for stack-on storage and organizers.
- Grommet can be replaced with optional Power Hub or Power/USB Hub for easy plug-and-play. See page 322.
- Shells utilize 10500 Series™ mobile pedestals or modular pedestals. See pages 258-260.
- See pages 304-305 for modular storage components.

HOW TO SPECIFY

Select Model Number

H 1 0 7 8 2 7 .



Select Laminate

See page 293

N N

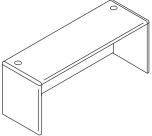
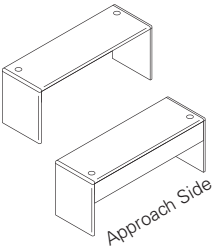

10700 SERIES™ Laminate Modular Components

	DESCRIPTION	INSIDE DIMENSIONS	MODEL	SHIP WEIGHT	CUBE	LIST PRICE
	Credenza Shell w/Full Modesty Panel					
	72"W x 24"D x 29½"H	69½"W x 22¾"D	H107817	156	6.0	\$904
	66"W x 24"D x 29½"H	63½"W x 22¾"D	H107816	145	5.5	\$843
	60"W x 24"D x 29½"H	57½"W x 22¾"D	H107815	133	5.0	\$796
	72"W x 20"D x 29½"H	69½"W x 18¾"D	H107837	140	5.3	\$883
	66"W x 20"D x 29½"H	63½"W x 18¾"D	H107836	132	4.8	\$823
	60"W x 20"D x 29½"H	57½"W x 18¾"D	H107835	127	3.8	\$782
	NOTES: One cord pass-through grommet in top center of modesty panel to reach wall electrical outlets. See pages 312-313 for optional stack-on storage.					
	Credenza Shell w/10"H Modesty Panel					
	72"W x 24"D x 29½"H	69½"W x 22¾"D	H107817X	127	6.0	\$904
	66"W x 24"D x 29½"H	63½"W x 22¾"D	H107816X	121	5.5	\$843
	60"W x 24"D x 29½"H	57½"W x 22¾"D	H107815X	115	5.0	\$796
	NOTES: Makes reaching wall electrical outlets quick and easy. Provides more than 18" of clearance. See pages 312-313 for optional stack-on storage.					
	Kneespace Clearance End Panel Kits (field installable)					
	1½"W x 11¼"D x 28⅞"H		H105098	13	0.9	\$210
	For use at either end of 10700, 10500 or Valido Series® 24"D Credenza Shells (with full or 10" modesty panel) or non-pedestal end of single pedestal credenzas or credenzas with lateral files.					
	1⅞"W x 17¼"D x 28⅞"H		H105099	11	0.8	\$220
	For use at either end of 10700, 10500 or Valido Series® 30"D Desk Shells or non-pedestal end of 30"D single pedestal desks.					
	Kits include: (1) support panel; European fastening hardware; flat connector bracket; joint connector bolts with sleeve nuts (for ganging credenza to adjacent worksurface); and adjustable leveling glides. Allows conversion of units currently in the field.					
	NOTES: Can be used to connect up to three 24"D credenzas or 30"D desks in line (requires 4 kits).					
	⚠ Not designed to be used freestanding. Not designed to be used with returns, 36"D desks or desk shells.					
	SPECIFYING EXAMPLE: H105098.N					

NOTES:

- Desk, credenza, and return shells, combined with a variety of under-the-worksurface storage solutions, maximize office layout flexibility. Products can be reconfigured quickly and easily when user preferences or space needs change.
- Worksurfaces and end panels feature contract-grade scratch, stain and spill resistant laminate over durable 1/8" solid core high-performance particleboard; resists warping.
- Contoured hardwood trim; stained to match laminate.
- User friendly waterfall-shaped edges and rounded corners.
- Formal, full height or 10" modesty panels.
- Cord management grommets, for routing and hiding wires and cables, are located in the tops of desk, credenza, and return shells. Grommets also serve as anchor points for stack-on storage and organizers.
- Shells utilize 10500 Series™ mobile pedestals or modular pedestals. See pages 258-260.
- See pages 304-305 for modular storage components.

HOW TO SPECIFY

Select Model Number	Select Laminate
	See page 293
H 1 0 7 8 1 7 .	N N

10700 SERIES™

Laminate Modular Components

GSA SIN 33721



Icon Legend on page 19

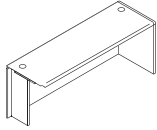

Model H10772R shown

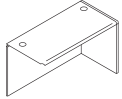

Model H107805R shown

DESCRIPTION	INSIDE DIMENSIONS	MODEL	SHIP WEIGHT	CUBE	LIST PRICE
Right Return Shell w/Full Modesty Panel					
72"W x 24"D x 29½"H, Right (w/support; 2 grommets)	67"W x 22¾"D	H10772R	145	5.6	\$904
60"W x 24"D x 29½"H, Right (w/support; 2 grommets)	55"W x 22¾"D	H107807R	129	4.7	\$796
48"W x 24"D x 29½"H, Right (2 grommets)	47"W x 22¾"D	H107805R	100	4.0	\$637
42"W x 24"D x 29½"H, Right (2 grommets)	41"W x 22¾"D	H107803R	95	3.5	\$608
36"W x 24"D x 29½"H, Right (2 grommets)	34¾"W x 22⅝"D	H107801R	83	3.4	\$608
30"W x 24"D x 29½"H (1 grommet)	28¾"W x 22¾"D	H107725R	69	2.4	\$591
Left Return Shell w/Full Modesty Panel					
72"W x 24"D x 29½"H, Left (w/support; 2 grommets)	67"W x 22¾"D	H107728L	145	5.6	\$904
60"W x 24"D x 29½"H, Left (w/support; 2 grommets)	55"W x 22¾"D	H107808L	129	4.7	\$796
48"W x 24"D x 29½"H, Left (2 grommets)	47"W x 22¾"D	H107806L	100	4.0	\$637
42"W x 24"D x 29½"H, Left (2 grommets)	41"W x 22¾"D	H107804L	95	3.5	\$608
36"W x 24"D x 29½"H, Left (2 grommets)	34¾"W x 22⅝"D	H107802L	83	3.4	\$608
30"W x 24"D x 29½"H (1 grommet)	28¾"W x 22¾"D	H107726L	69	2.4	\$591

NOTES: One cord pass-through grommet in top center of modesty panel to reach wall electrical outlets. Woodgrain direction on modesty/back panel runs vertical on 30"W-60"W sizes and horizontal on 72"W unit. Stack-on model H10734 is sized to be used on the 72"W return shell. Stack-on model H10732 will work on the 60"W return shell. Stack-on storage model H107313 fits on the 48"W return shell. Stack-on storage model H10734 will work on a 36"W return shell attached to the 36" corner unit; attaches to the return shell through the grommet hole and to the corner unit via double-sided tape. 36"W return shell can be used to achieve a 6' x 6' footprint when connected to either a 72"W x 36"D single pedestal desk, desk shell or peninsula, or when two are connected to a 36" corner unit model H107811.

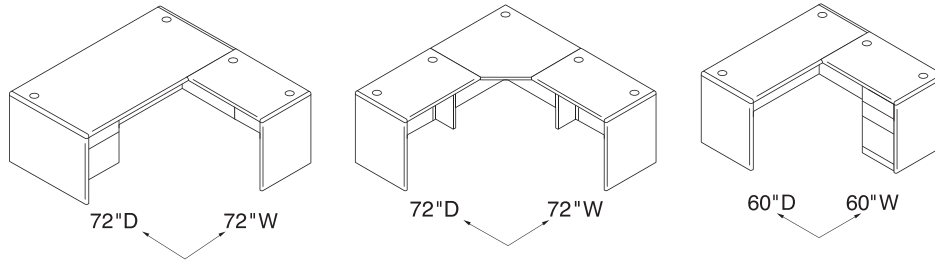

! All 10700 Series™ grommets on desk, credenza, credenza shell, return, return shell, bridge and corner unit worksurfaces changed from rectangle-shaped to round, effective November, 2011.

NOTES:

- Worksurfaces and end panels feature contract-grade scratch, stain and spill resistant laminate over durable 1½" solid core high-performance particleboard; resists warping.
- Contoured hardwood trim; stained to match laminate.
- User friendly waterfall-shaped edges and rounded corners.
- Formal, full height or 10" modesty panels.
- Cord management grommets, for routing and hiding wires and cables, are located in the tops of desk, credenza, and return shells. Grommets also serve as anchor points for stack-on storage and organizers.
- For work-in-process paper management tools, see page 319.
- For conference table options, see the Preside® table tops and bases on pages 774-779.
- Shells utilize 10500 Series™ mobile pedestals or modular pedestals. See pages 258-260.
- See pages 304-305 for modular storage components.

HOW TO SPECIFY

Select
Model Number

H 1 0 7 7 2 7 R .

Select
Laminate

See page 293

N N

	DESCRIPTION	INSIDE DIMENSIONS	MODEL	SHIP WEIGHT	CUBE	LIST PRICE
	Right Return Shell w/10" H Modesty Panel					
	72"W x 24"D x 29½"H, Right (w/support; 2 grommets)	67"W x 22¾"D	H107727RX	113	5.6	\$904
	60"W x 24"D x 29½"H, Right (w/support; 2 grommets)	55"W x 22¾"D	H107807RX	105	4.7	\$796
	48"W x 24"D x 29½"H, Right (2 grommets)	47"W x 22¾"D	H107805RX	81	4.0	\$637
	42"W x 24"D x 29½"H, Right (2 grommets)	41"W x 22¾"D	H107803RX	78	3.5	\$608
	36"W x 24"D x 29½"H, Right (2 grommets)	34¾"W x 22⅞"D	H107801RX	69	3.4	\$608
	Left Return Shell w/10" H Modesty Panel					
	72"W x 24"D x 29½"H, Left (w/support; 2 grommets)	67"W x 22¾"D	H107728LX	113	5.6	\$904
	60"W x 24"D x 29½"H, Left (w/support; 2 grommets)	55"W x 22¾"D	H107808LX	105	4.7	\$796
	48"W x 24"D x 29½"H, Left (2 grommets)	47"W x 22¾"D	H107806LX	81	4.0	\$637
	42"W x 24"D x 29½"H, Left (2 grommets)	41"W x 22¾"D	H107804LX	78	3.5	\$608
	36"W x 24"D x 29½"H, Left (2 grommets)	34¾"W x 22⅞"D	H107802LX	69	3.4	\$608

NOTES: Makes reaching wall electrical outlets quick and easy. Provides more than 18" of clearance.

	Non-Handed Return Shell w/10" H Modesty Panel					
	30"W x 20"D x 29½"H	28¾"W x 18¾"D	H107270X	47	2.4	\$564

NOTES: Makes reaching wall electrical outlets quick and easy; provides more than 18" of clearance. Ideal for smaller spaces. Connects to single pedestal desks and credenzas, peninsulas, or desk or credenza shells. Designed to fit over 10500 Series™ mobile pedestal models H105106 (box/file) or H105109 (shelf/box/file) and modular pedestal models H105012 (box/box/file) or H105014 (file/file).

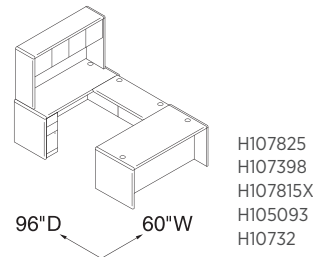
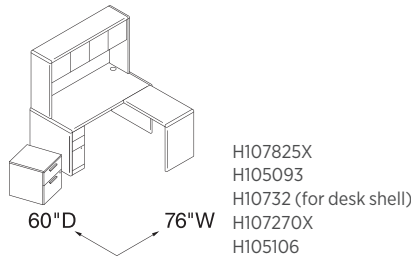

! All 10700 Series™ grommets on desk, credenza, credenza shell, return, return shell, bridge and corner unit worksurfaces changed from rectangle-shaped to round, effective November, 2011.

NOTES:

- Worksurfaces and end panels feature contract-grade scratch, stain and spill resistant laminate over durable 1½" solid core high-performance particleboard; resists warping.
- Contoured hardwood trim; stained to match laminate.
- User friendly waterfall-shaped edges and rounded corners.
- Formal, full height or 10" modesty panels.
- 3" round cord management grommets, for routing and hiding wires and cables, are located in the tops of desk, credenza, and return shells. Grommets also serve as anchor points for stack-on storage and organizers.
- Grommet can be replaced with optional Power Hub or Power/USB Hub for easy plug-and-play. See page 322.
- For conference table options, see the Preside® table tops and bases on pages 774-779.
- Shells utilize 10500 Series™ mobile pedestals or modular pedestals. See pages 258-260.
- See pages 304-305 for modular storage components.

! Disperse fabrics not available on 72"W panels.

HOW TO SPECIFY

<p>Select Model Number</p> <p>H 1 0 7 7 2 7 R X</p>	<p>Select Laminate</p> <p>See page 293</p> <p>N N</p>
---	---

10700 SERIES™

Laminate Modular Components

GSA SIN 33721

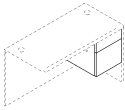
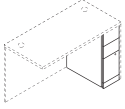
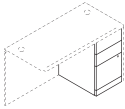
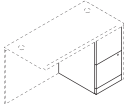
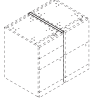

Icon Legend on page 19

	DESCRIPTION	MODEL	SHIP WEIGHT	CUBE	LIST PRICE
	Box/File Pedestal (with core removable lock) 15 $\frac{3}{4}$ "W x 22 $\frac{3}{4}$ "D x 17 $\frac{3}{4}$ "H — for use under 24"D, 30"D and 36"D desk, credenza and return shells NOTES: Hangrails included. Lock can be positioned on either the right or left side. Attaches to underside of worksurface top. Not for use under 20"D shells. ⓘ Not designed to be used freestanding. Unfinished top and back.	H10501	57	5.5	\$523
	Narrow Box/Box/File Pedestal (with core removable lock) — floor-standing 9 $\frac{1}{2}$ "W x 22 $\frac{3}{4}$ "D x 28"H — for use under 24"D, 30"D and 36"D desk, credenza and return shells NOTES: Compact design is ideal for use in U- and L-shaped layouts for smaller spaces such as 5' x 8' U-workstation or a 5' x 5' L-workstation. Middle box drawer and file drawer lock; top box drawer does not lock. File drawer includes integrated hangrails for side-to-side letter or legal filing. Field installable handle choices for this model are the Sweep, Crescent, and Arch only. Not for use with 20"D shells. ⓘ Not designed to be used freestanding; unfinished top and back.	H105093	61	5.6	\$676
	Box/Box/File Pedestal (with core removable lock) — floor-standing 15 $\frac{3}{4}$ "W x 22 $\frac{3}{4}$ "D x 28"H — for use under 24"D, 30"D and 36"D desk, credenza and return shells NOTES: Top box drawer does not lock. Hangrails included. Not for use under 20"D shells. ⓘ Not designed to be used freestanding. Unfinished top and back.	H10502	90	8.4	\$686
	File/File Pedestal (with core removable lock) — floor-standing 15 $\frac{3}{4}$ "W x 22 $\frac{3}{4}$ "D x 28"H — for use under 24"D, 30"D and 36"D desk, credenza and return shells NOTES: Hangrails included. Not for use under 20"D shells. ⓘ Not designed to be used freestanding. Unfinished top and back.	H10504	85	8.2	\$686
	Access Strip (Filler) 1 $\frac{1}{8}$ "W x 20 $\frac{1}{2}$ "D x 28"H NOTES: For use with B/B/F, F/F, and or P/M/F pedestals are configured side-by-side. Not required when pedestals are used in conjunction with lateral file pedestal, multi file pedestal or cabinet pedestal. Not for use under 20"D shells. ⓘ All 10700 Series™ grommets on desk, credenza, credenza shell, return, return shell, bridge and corner unit worksurfaces changed from rectangle-shaped to round, effective November, 2011.	H10524	21	0.9	\$176

NOTES:



- Pedestals can be reconfigured quickly and easily when user preferences or space needs change.
- Pedestal models ship assembled unless designated ⓘ.
- Locking units equipped with interchangeable core removable locks.
- See pages 300-303 for modular desk, credenza and return shells.
- ⓘ Keyed alike cores must be ordered separately — see page 853.
- ⓘ Pedestals are not designed to be used freestanding. Unfinished top and back.
- ⓘ Access strip (filler) required when full height pedestals are configured side-by-side to allow access for opening the drawers.

HOW TO SPECIFY

Select Model Number H 1 0 5 0 1	Select Laminate See page 293 N
---	---

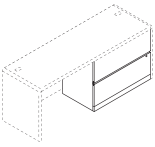
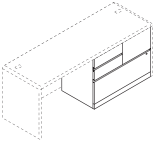
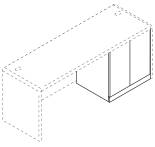

10700 SERIES™ Laminate Modular Components

	DESCRIPTION	MODEL	SHIP WEIGHT	CUBE	LIST PRICE
	<p>Lateral File Pedestal (with core removable lock) – floor-standing 36"W x 20"D x 28"H — for use under 24"D, 30"D and 36"D desk, credenza and return shells</p> <p>NOTES: Designed for use with credenza or return shells. Hangrails included. Mechanical interlock inhibits extension of more than one drawer at a time. Not for use under 20"D shells.</p> <p>! Not designed to be used freestanding. Unfinished top and back.</p>	H10503	127	15.6	\$1042
	<p>Multi File Pedestal (with core removable lock) – floor-standing 36"W x 20"D x 28"H — for use under 24"D, 30"D and 36"D desk, credenza and return shells</p> <p>NOTES: Designed for use with credenza or return shells. Versatile four drawer unit features one lateral file drawer, one vertical file drawer, and two box drawers. Box drawers do not lock. Hangrails included. Mechanical interlock in lateral drawer inhibits extension of more than one drawer at a time. Not for use under 20"D shells.</p> <p>! Not designed to be used freestanding. Unfinished top and back.</p>	H10505	155	15.6	\$1249
	<p>Cabinet Pedestal – floor-standing 26"W x 21¼"D x 28"H — for use under 24"D, 30"D and 36"D desk, credenza and return shells</p> <p>NOTES: One adjustable shelf at 2½" increments. For use with credenza or return shells. Doors are non-locking. Not for use under 20"D shells.</p> <p>! Not designed to be used freestanding. Unfinished top and back.</p>	H10508	78	12.2	\$777
	<p>Mobile Printer/Fax Cart 20"W x 19⅞"D x 14⅞"H</p> <p>NOTES: Holds laser printers, inkjet printers or fax machines. Ideal for limited space. Low profile cart stores conveniently and easily under desks and workstations. Interior compartment shelving is Black. Four casters. Not for use under 20"D shells. Flat edge profile on top.</p> <p>SPECIFYING EXAMPLE: H105679.NN</p> <p>! All 10700 Series™ grommets on desk, credenza, credenza shell, return, return shell, bridge and corner unit worksurfaces changed from rectangle-shaped to round, effective November, 2011.</p>	H105679	52	2.9	\$420

NOTES:

- Pedestals can be reconfigured quickly and easily when user preferences or space needs change.
- Locking units equipped with interchangeable core removable locks.
- See pages 300-303 for modular desk, credenza and return shells.
- ! Keyed alike cores must be ordered separately — see HF23B on page 853.
- ! Pedestals are not designed to be used freestanding. Unfinished top and back.
- ! Access strip (filler) required when full height pedestals are configured side-by-side to allow access for opening the drawers.

HOW TO SPECIFY

Select Model Number H 1 0 5 0 3 . N	Select Laminate See page 293
---	--

10700 SERIES™

Laminate Wood Desks — Full Pedestals

GSA SIN 33721



Icon Legend on page 19

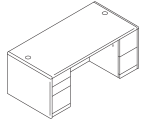

DESCRIPTION	RECESSED MODESTY PANEL	MODEL	SHIP WEIGHT	CUBE	LIST PRICE
Double Pedestal Desk w/Woodgrain Breakfront Modesty Panel — 3/2					
72"W x 36"D x 29½"H	10½"	H10799	371	52.9	\$2081
66"W x 30"D x 29½"H	4½"	H10774	313	40.9	\$2007
60"W x 30"D x 29½"H	4½"	H10773	305	37.3	\$1910
NOTES: All drawers lock. Two worksurface grommets to route/hide cords. See page 320 for optional center drawers.					

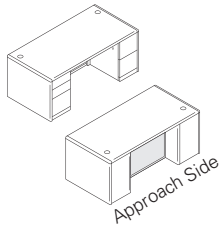

Double Pedestal Desk w/Frosted Breakfront Modesty Panel — 3/2					
72"W x 36"D x 29½"H	10½"	H10799G	366	51.8	\$2550
NOTES: All drawers lock. Two worksurface grommets to route/hide cords. See page 320 for optional center drawers.					

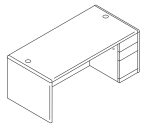

Single Pedestal Desk w/Woodgrain Breakfront Modesty Panel — Box/box/file					
72"W x 36"D x 29½"H, Right	10½"	H10787R	317	52.9	\$1796
66"W x 30"D x 29½"H, Right	4½"	H10701R	270	40.9	\$1651
72"W x 36"D x 29½"H, Left	10½"	H10788L	317	52.9	\$1796
66"W x 30"D x 29½"H, Left	4½"	H10702L	270	40.9	\$1651
NOTES: Drawers lock. Two worksurface grommets to route/hide cords. See page 320 for optional center drawers.					

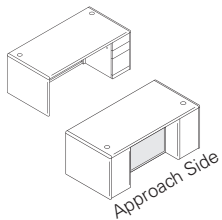

Single Pedestal Desk w/Frosted Breakfront Modesty Panel — Box/box/file					
72"W x 36"D x 29½"H, Right	10½"	H10787RG	313	51.8	\$2265
72"W x 36"D x 29½"H, Left	10½"	H10788LG	313	51.8	\$2265
NOTES: Drawers lock. Two worksurface grommets to route/hide cords. See page 320 for optional center drawers.					

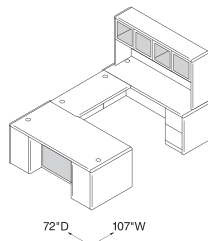

H10788L
H10770
H10707R
H10734G

! All 10700 Series™ grommets on desk, credenza, credenza shell, return, return shell, bridge and corner unit worksurfaces changed from rectangle-shaped to round, effective November, 2011.

NOTES:

- Worksurfaces and end panels feature contract-grade scratch, stain and spill resistant high-pressure laminate over durable 1/8" solid core high-performance particleboard.
- Contoured hardwood trim; stained to match laminate.
- User friendly waterfall-shaped edges.
- Full-to-floor pedestals maximize storage space.
- Breakfront modesty panel design on full height pedestal desks. See approach side illustration above.
- Grommet can be replaced with optional Power Hub or Power/USB Hub for easy plug-and-play. See page 322.
- All drawers are 5-sided construction, which allows easy drawer alignment or replacement of drawer fronts.
- File drawer design includes integrated handrails for side-to-side letter or legal filing; and front-to-back for letter filing.
- Adjustable hex leveling glides allow floor-standing furniture to be easily leveled without lifting the unit; glides have 3/4" adjustable range.
- Desk, credenza, and return models ship assembled; ready to set in place.
- See pages 310-322 for shared components.

HOW TO SPECIFY

Select Model Number	Select Laminate
H 1 0 7 9 9 .	See page 293
N N	



10700 SERIES™

Laminate Wood Desks — Full Pedestals

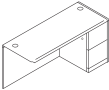
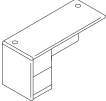
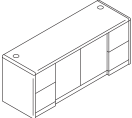
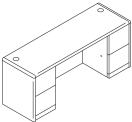
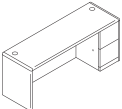
	DESCRIPTION	RECESSED MODESTY PANEL	MODEL	SHIP WEIGHT	CUBE	LIST PRICE
	Return — Right file/file (2 grommets)					
	60"W x 24"D x 29½"H		H10709R	176	29.7	\$1275
	48"W x 24"D x 29½"H		H10711R	158	24.9	\$1105
	42"W x 24"D x 29½"H		H107191R	150	22.1	\$1092
	NOTES: Drawers lock. Two worksurface grommets to route/hide cords and one cord pass-through grommet in top center of modesty panel. See pages 312-313 for optional stack-on storage.					
	⚠ Not designed to be used freestanding.					
	Return — Left file/file (2 grommets)					
	60"W x 24"D x 29½"H		H10710L	176	29.7	\$1275
	48"W x 24"D x 29½"H		H10712L	158	24.9	\$1105
	42"W x 24"D x 29½"H		H107192L	150	22.1	\$1092
	NOTES: Drawers lock. Two worksurface grommets to route/hide cords and one cord pass-through grommet in top center of modesty panel. See pages 312-313 for optional stack-on storage.					
	⚠ Not designed to be used freestanding.					
	Credenza with Doors					
	72"W x 24"D x 29½"H	3½"	H10742	314	36.0	\$2081
	NOTES: All drawers lock. Doors are non-locking. Two worksurface grommets to route/hide cords and one pass-through grommet in top center of modesty panel. Includes a fixed shelf located at the bottom of the center storage area. No intermittent shelf. See pages 312-313 for optional stack-on storage.					
	Credenza with Kneespace — 2/0/2					
	72"W x 24"D x 29½"H	3½"	H10741	280	36.0	\$1796
	66"W x 24"D x 29½"H	3½"	H10768	270	33.4	\$1689
	60"W x 24"D x 29½"H	3½"	H10767	241	28.8	\$1641
	NOTES: All drawers lock. Two worksurface grommets to route/hide cords and one pass-through grommet in top center of modesty panel. See pages 312-313 for optional stack-on storage.					
	⚠ Not designed to be used with 22¾"D modular or mobile pedestals. Modesty/back panel is inset 3½".					
	Single Pedestal Credenza, File/File					
	72"W x 24"D x 29½"H, Right	3½"	H10707R	235	36.3	\$1469
	66"W x 24"D x 29½"H, Right	3½"	H10705R	225	33.4	\$1444
	72"W x 24"D x 29½"H, Left	3½"	H10708L	235	36.3	\$1469
	66"W x 24"D x 29½"H, Left	3½"	H10706L	225	33.4	\$1444
	NOTES: Drawers lock. Two worksurface grommets to route/hide cords and one cord pass-through grommet in top center of modesty panel. See pages 312-313 for optional stack-on storage.					
	⚠ Not designed to be used with 22¾"D modular or mobile pedestals. Modesty/back panel is inset 3½".					
	⚠ All 10700 Series™ grommets on desk, credenza, credenza shell, return, return shell, bridge and corner unit worksurfaces changed from rectangle-shaped to round, effective November, 2011.					

NOTES:

- Worksurfaces and end panels feature contract-grade scratch, stain and spill resistant high-pressure laminate over durable 1/8" solid core high-performance particleboard.
- Contoured hardwood trim; stained to match laminate.
- User friendly waterfall-shaped edges.
- Full-to-floor pedestals maximize storage space.
- Breakfront modesty panel design on full height pedestal desks. See approach side illustration on page 306.
- Cord management grommets serve as anchor points for stack-on storage and organizers.
- All drawers are 5-sided construction, which allows easy drawer alignment or replacement of drawer fronts.
- File drawer design includes integrated hangrails for side-to-side letter or legal filing; and front-to-back for letter filing.
- Adjustable hex leveling glides allow floor-standing furniture to be easily leveled without lifting the unit; glides have 3/4" adjustable range.
- Desk, credenza, and return models ship assembled; ready to set in place.
- For work-in-process paper management tools, see page 319.
- See pages 310-322 for shared components.

HOW TO SPECIFY

Select Model Number	Select Laminate
H 1 0 7 0 9 R .	See page 293
	N N

10700 SERIES™

Laminate Wood Desks — 3/4 Pedestals

GSA SIN 33721

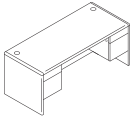
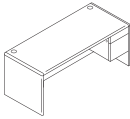
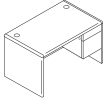
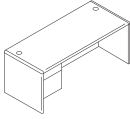
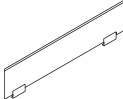

Icon Legend on page 19

	DESCRIPTION	FULL WIDTH OVERHANG	MODEL	SHIP WEIGHT	CUBE	LIST PRICE
	Double Pedestal Desk, 2-2					
	72"W x 36"D x 29½"H	10½"	H10791	340	52.9	\$1625
	66"W x 30"D x 29½"H	4½"	H10775	290	40.9	\$1552
	60"W x 30"D x 29½"H	4½"	H10771	266	37.4	\$1367
NOTES: All drawers lock. Two worksurface grommets to route/hide cords. See page 320 for optional center drawers.						
	Single Pedestal Desk, Right box/file					
	72"W x 36"D x 29½"H	10½"	H10785R	279	52.9	\$1346
	66"W x 30"D x 29½"H	4½"	H10783R	239	41.0	\$1228
NOTES: Drawers lock. Two worksurface grommets to route/hide cords. See page 320 for optional center drawers.						
	Small Office Desk, 3/4 Pedestal, Right box/file					
	48"W x 30"D x 29½"H		H107885R	191	30.2	\$1126
NOTES: Footprint is ideal for limited space. Drawers lock. Two cord management grommets in the top. 3/4 height modesty panel facilitates reaching wall electrical outlets. Optional stack-on storage model H107313 maximizes storage space. See page 320 for optional center drawers.						
	Single Pedestal Desk, Left box/file					
	72"W x 36"D x 29½"H	10½"	H10786L	279	52.9	\$1346
	66"W x 30"D x 29½"H	4½"	H10784L	239	41.0	\$1228
NOTES: Drawers lock. Two worksurface grommets to route/hide cords. See page 320 for optional center drawers.						
<p>! All 10700 Series™ grommets on desk, credenza, credenza shell, return, return shell, bridge and corner unit worksurfaces changed from rectangle-shaped to round, effective November, 2011.</p>						
	Above Privacy Screen					
	60"W x 13"H		HLSL1260	24	2.9	\$453
	54"W x 13"H		HLSL1254	22	2.9	\$421
	48"W x 13"H		HLSL1248	20	2.3	\$394
	42"W x 13"H		HLSL1242	18	2.3	\$344
	36"W x 13"H		HLSL1236	15	1.8	\$308
30"W x 13"H		HLSL1230	13	1.5	\$279	
NOTES: Ships complete with attachment bracket. Bracket is Platinum only, no need to specify. Attaches to top of rectangle worksurfaces; requires a minimum overhang of 1½".						
<p>! Available in Frosted Glass ONLY HLSL1230.G.</p> <p>! Above only Privacy Screen clamps onto worksurface and cannot be installed where support storage will be attached.</p>						

NOTES:

- Worksurfaces and end panels feature contract-grade scratch, stain and spill resistant high-pressure laminate over durable 1½" solid core high-performance particleboard.
- Contoured hardwood trim; stained to match laminate.
- User friendly waterfall-shaped edges and rounded corners.
- 3/4 pedestal design increases budget flexibility.
- Formal, full height modesty panels.
- Drawers operate on full extension, ball-bearing suspensions to ensure smooth, quiet, long-lasting operation.
- All drawers are 5-sided construction, which allows easy drawer alignment or replacement of drawer fronts.
- File drawer design includes integrated hangrails for side-to-side letter or legal filing; and front-to-back for letter filing.
- Grommet can be replaced with optional Power Hub or Power/USB Hub for easy plug-and-play. See page 322.
- Adjustable hex leveling glides allow floor-standing furniture to be easily leveled without lifting the unit; glides have ¾" adjustable range.
- Desk, credenza, and return models ship assembled; ready to set in place.
- Center drawers conveniently store writing instruments, paper and other miscellaneous items. Includes pencil tray. See page 320.
- See pages 310-322 for shared components.

HOW TO SPECIFY

Select Model Number	Select Laminate
H 1 0 7 9 1 .	See page 293
	N N



10700 SERIES™

Laminate Wood Desks — 3/4 Pedestals

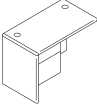
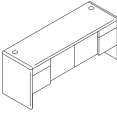
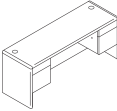
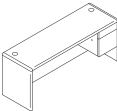
	DESCRIPTION	FULL WIDTH OVERHANG	MODEL	SHIP WEIGHT	CUBE	LIST PRICE
 <p>Model H10717R shown</p>	Return — Right box/file (2 grommets)					
	60"W x 24"D x 29½"H		H10717R	173	29.7	\$1025
	48"W x 24"D x 29½"H		H10715R	147	25.3	\$905
	42"W x 24"D x 29½"H		H107193R	136	22.1	\$881
	NOTES: Drawers lock. Two worksurface grommets and one cord pass-through grommet in top center of modesty panel. See pages 312-313 for optional stack-on storage.					
	⚠ Not designed to be used freestanding.					
 <p>Model H10716L shown</p>	Return — Left box/file (2 grommets)					
	60"W x 24"D x 29½"H		H10718L	173	29.7	\$1025
	48"W x 24"D x 29½"H		H10716L	147	25.3	\$905
	42"W x 24"D x 29½"H		H107194L	136	22.1	\$881
	NOTES: Drawers lock. Two worksurface grommets and one cord pass-through grommet in top center of modesty panel to reach wall electrical outlets. See pages 312-313 for optional stack-on storage.					
	⚠ Not designed to be used freestanding.					
	Credenza with Doors	3½"	H10744	278	36.0	\$1638
	72"W x 24"D x 29½"H					
	NOTES: All drawers lock. Hinged doors are non-locking. Two worksurface grommets and one cord pass-through grommet in top center of modesty panel to reach wall electrical outlets. Includes a fixed shelf located at the bottom of the center storage area. No intermittent shelf. See pages 312-313 for optional stack-on storage.					
	Credenza with Kneespace					
	72"W x 24"D x 29½"H	3½"	H10743	243	36.3	\$1461
	66"W x 24"D x 29½"H	3½"	H10766	234	33.4	\$1365
	60"W x 24"D x 29½"H	3½"	H10765	229	28.8	\$1304
	NOTES: Drawers lock. Two worksurface grommets and one cord pass-through grommet in top center of modesty panel to reach wall electrical outlets. See pages 312-313 for optional stack-on storage.					
	⚠ Not designed to be used with 22¾"D modular or mobile pedestals. Modesty/back panel is inset 3½".					
	Single Pedestal Credenza, Box/File					
	72"W x 24"D x 29½"H, Right	3½"	H10745R	212	36.0	\$1181
	66"W x 24"D x 29½"H, Right	3½"	H10763R	203	33.4	\$1161
	72"W x 24"D x 29½"H, Left	3½"	H10746L	212	36.0	\$1181
	66"W x 24"D x 29½"H, Left	3½"	H10764L	203	33.4	\$1161
	NOTES: Drawers lock. Two worksurface grommets and one cord pass-through grommet in top center of modesty panel to reach wall electrical outlets. See pages 312-313 for optional stack-on storage.					
	⚠ Not designed to be used with 22¾"D modular or mobile pedestals. Modesty/back panel is inset 3½".					
	⚠ All 10700 Series™ grommets on desk, credenza, credenza shell, return, return shell, bridge and corner unit worksurfaces changed from rectangle-shaped to round, effective November, 2011.					

NOTES:

- Worksurfaces and end panels feature contract-grade scratch, stain and spill resistant high-pressure laminate over durable 1½" solid core high-performance particleboard.
- Contoured hardwood trim; stained to match laminate.
- User friendly waterfall-shaped edges and rounded corners.
- 3/4 pedestal design increases budget flexibility.
- Formal, full height modesty panels.
- Cord management grommets also serve as anchor points for stack-on storage and organizers.
- All drawers are 5-sided construction, which allows easy drawer alignment or replacement of drawer fronts.
- File drawer design includes integrated hangrails for side-to-side letter or legal filing; and front-to-back for letter filing.
- Adjustable hex leveling glides allow floor-standing furniture to be easily leveled without lifting the unit; glides have ¾" adjustable range.
- Desk, credenza, and return models ship assembled; ready to set in place.
- For work-in-process paper management tools, see page 319.
- See pages 310-322 for shared components.

HOW TO SPECIFY

Select Model Number H 1 0 7 4 5 R	Select Laminate See page 293 N N
---	---



10700 SERIES™

Shared Components and Accessories

GSA SIN 33721

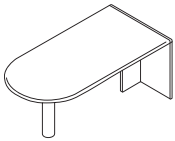

Icon Legend on page 19

	DESCRIPTION	MODEL	SHIP WEIGHT	CUBE	LIST PRICE
	Peninsula w/End Panel and Steel Support Column 72"W x 36"D x 29½"H 66"W x 30"D x 29½"H NOTES: Use for "U" or "L" configuration. Cord routing notch in brace panel. Round support column is black. Peninsula models H10721 and H10722 ship complete with end panel and black 4½" diameter support column. For a silver support column option, please see model HPC191X on page 251 (ordered separately).	H10721	150	15.1	\$1329
		H10722	125	11.8	\$1161
	Field Installable Laminate Modesty Panel 50¼"W x ¾"Thick x 18"H NOTES: Center drawer model H1522 can be used in conjunction with modesty panel. Cord pass-through notch in top corner of modesty panel. See page 320 for optional center drawers. ! Not designed to attach to peninsulas manufactured prior to 12/1/2001. SPECIFYING EXAMPLE: H10528.N	H10528	25	1.3	\$188
	Field Installable Modesty Panel, Frosted with Silver Frame 50¼"W x ¾"Thick x 18"H — for use on 72"W peninsulas ! Center drawers not designed to be used with the frosted/silver modesty panel.	HPC180G	33	1.5	\$694

NOTES:

- Shared components on this page can be used with modular, full pedestal, and ¾ pedestal models shown on pages 300-309.
 - Multi file is a versatile four drawer unit featuring two box drawers, one file drawer, and one lateral file drawer with mechanical interlock.
 - Cord management grommets, for routing and hiding wires and cables, are located in the tops of desks, credenzas, and returns. Grommets also serve as anchor points for stack-on storage and organizers.
 - Cord pass-through grommet located in the back/modesty panel of returns, bridges and credenzas, facilitates reaching wall electrical outlets.
 - All drawers are 5-sided construction, which allows easy drawer alignment or replacement of drawer fronts.
 - Locking units equipped with interchangeable core removable locks.
 - Stack-on storage attaches with two removable mounting brackets.
 - Adjustable hex leveling glides allow floor-standing furniture to be easily leveled without lifting the unit; glides have ¾" adjustable range.
 - See pages 310-322 for shared components.
- ! Keyed alike cores must be ordered separately — see page 853.

HOW TO SPECIFY

Select Model Number H 1 0 7 2 1 .	Select Laminate See page 293 N N
---	---



DESCRIPTION

Corner Unit

24" x 36" x 36" x 24" x 29½"H - (1 grommet in top)
Works with 24"D x 29½"H returns or bridges.

NOTES: The corner unit has rounded, solid wood trim on the front and back. Return and bridge connections are inset inside the wood profiles, per the drawing shown. Support legs feature cutouts for routing cords. Can be used freestanding.

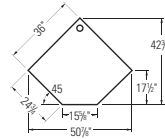

MODEL **SHIP WEIGHT** **CUBE** **LIST PRICE**

H107811 136 4.2 **\$1196**

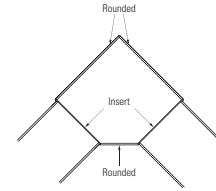

DESCRIPTION

Bridge (Single Ped. Desk, Desk Shell or Peninsula to Corner Unit or Single Ped. Credenza or Credenza Shell)

47"W x 24"D x 29½"H, (Clear inside depth = 22¾"D)
42"W x 24"D x 29½"H, (Clear inside depth = 22¾"D)
36"W x 24"D x 29½"H, (Clear inside depth = 22¾"D) (for use with Corner Units)
47"W x 20"D x 29½"H, (Clear inside depth = 18¾"D)
42"W x 20"D x 29½"H, (Clear inside depth = 18¾"D)

NOTES: Two cord grommets in top; one cord pass-through grommet in top center of modesty panel. Grommets can be replaced with optional Power Hub or Power/USB Hub for easy plug-and-play (see page 322). Kneespace of desk limited to 24¾"W if bridge is used with 66"W single pedestal desk.



FULL WIDTH OVERHANG **MODEL** **SHIP WEIGHT** **CUBE** **LIST PRICE**

H10770 81 2.5 **\$409**
H10760 69 2.6 **\$394**
H10751 64 2.5 **\$390**
H107399 68 2.8 **\$394**
H107398 56 2.6 **\$381**

Credenza with 36" Lateral (with core removable lock) - 2 cord grommets in top

72"W x 24"D x 29½"H, Right 3½"
72"W x 24"D x 29½"H, Left 3½"

NOTES: One cord pass-through grommet in top center of modesty panel. Mechanical interlock inhibits the extension of more than one drawer at a time. Optional stack-on models H10734, H10734K, and H10734G maximize storage space.

⚠ Not designed to be used with 22¾"D modular or mobile pedestals. Modesty/back panel is inset 3½".

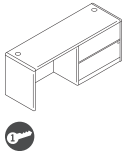

H10747R 247 36.0 **\$1626**
H10748L 247 36.0 **\$1626**

Credenza with Lateral File, Left and Storage Cabinet, Right

72"W x 24"D x 29½"H 3½" **H107492** 307 35.6 **\$2016**

NOTES: Lateral file is equipped with mechanical interlock to inhibit the extension of more than one drawer at a time. Storage cabinet has one adjustable interior shelf which adjusts in 1¼" increments over a range of 5". Drawers and doors lock separately; the two locks are keyed alike. Can be used with optional stack-on storage. See page 312 for Stack-on Storage models H10734/H10734K/H10734G.

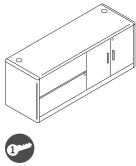

NOTES:

- Cord management grommets, for routing and hiding wires and cables, are located in the tops of desks, credenzas, and returns. Grommets also serve as anchor points for stack-on storage and organizers.
- Cord pass-through grommet located in the back/modesty panel of returns, bridges and credenzas, facilitates reaching wall electrical outlets.
- All drawers are 5-sided construction, which allows easy drawer alignment or replacement of drawer fronts.
- Locking units equipped with interchangeable core removable locks.
- Stack-on storage attaches with two removable mounting brackets.
- Adjustable hex leveling glides allow floor-standing furniture to be easily leveled without lifting the unit; glides have ¾" adjustable range.
- See pages 310-322 for shared components.

HOW TO SPECIFY

<p>Select Model Number</p> <p>H 1 0 7 7 0 .</p>	<p>Select Laminate</p> <p>See page 293</p> <p>N N</p>
--	--

10700 SERIES™

Shared Components and Accessories

GSA SIN 33721

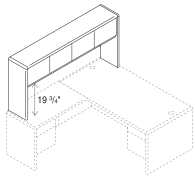

Icon Legend on page 19

**DESCRIPTION****Stack-on Storage for "L" Workstation**

74 $\frac{5}{8}$ "W x 14 $\frac{5}{8}$ "D x 37 $\frac{1}{8}$ "H
(Use Task Light model HH870960, see page 321)

MODEL**SHIP WEIGHT****CUBE****LIST PRICE****H107318**

198

15.8

\$1329**Stack-on Storage for "L" Workstation, Locking**

74 $\frac{5}{8}$ "W x 14 $\frac{5}{8}$ "D x 37 $\frac{1}{8}$ "H
(Use Task Light model HH870960, see page 321)

H107318K

198

15.8

\$1412

NOTES: Spans the total depth dimension of configurations comprised of: 48"W return or return shell attached to a 30"D single pedestal desk, desk shell or peninsula (78"D); 42"W return or return shell attached to a 36"D single pedestal desk, desk shell or peninsula (78"D) or 42"W return or return shell attached to a 36" corner unit (78"D). Attaches to desk, peninsula, or corner unit via double-sided tape, and to return through grommet hole. Inside storage consists of two compartments each 34 $\frac{3}{4}$ "W x 12 $\frac{7}{8}$ "D x 12"H. Use back enclosure model H107358 and model H90035. For vertical paper manager, see page 319.

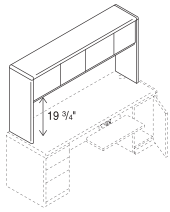
**Stack-on Storage**

68 $\frac{5}{8}$ "W x 14 $\frac{5}{8}$ "D x 37 $\frac{1}{8}$ "H, 4 doors (For 72"W Credenza)

H10734

175

16.0

\$1211

62 $\frac{5}{8}$ "W x 14 $\frac{5}{8}$ "D x 37 $\frac{1}{8}$ "H, 4 doors (For 66"W Credenza)

H10733

168

14.4

\$1195

56 $\frac{5}{8}$ "W x 14 $\frac{5}{8}$ "D x 37 $\frac{1}{8}$ "H, 4 doors (For 60"W Credenza or Return)

H10732

161

13.0

\$1161

44 $\frac{5}{8}$ "W x 14 $\frac{5}{8}$ "D x 37 $\frac{1}{8}$ "H, 3 doors (For 48"W Return or 48"W Small Office Desk)

H107313

147

10.3

\$1067**Stack-on Storage, Locking**

68 $\frac{5}{8}$ "W x 14 $\frac{5}{8}$ "D x 37 $\frac{1}{8}$ "H, 4 doors (For 72"W Credenza)

H10734K

175

16.0

\$1294

62 $\frac{5}{8}$ "W x 14 $\frac{5}{8}$ "D x 37 $\frac{1}{8}$ "H, 4 doors (For 66"W Credenza)

H10733K

168

14.4

\$1279

56 $\frac{5}{8}$ "W x 14 $\frac{5}{8}$ "D x 37 $\frac{1}{8}$ "H, 4 doors (For 60"W Credenza or Return)

H10732K

161

13.0

\$1244

44 $\frac{5}{8}$ "W x 14 $\frac{5}{8}$ "D x 37 $\frac{1}{8}$ "H, 3 doors (For 48"W Return or 48"W Small Office Desk)

H107313K

147

10.3

\$1109

NOTES: Inside storage for H10734, H10733 and H10732 contains two compartments each sized: 32 $\frac{1}{2}$ "W, 28 $\frac{3}{4}$ "W, 25 $\frac{3}{4}$ "W respectively x 12 $\frac{7}{8}$ "D x 12"H. H107313 has 3 doors. Inside storage for H107313 contains two compartments: right side 12 $\frac{7}{8}$ "W, left side 26 $\frac{3}{4}$ "W respectively x 12 $\frac{7}{8}$ "D x 12"H. Stack-ons attach through grommet holes on the worksurfaces of desks, credenzas and returns. Model 10734 can be used for "L" configuration comprised of 30"D desk, desk shell or peninsula and 42"W return or return shell; or a 36"D desk, desk shell, peninsula or corner unit and 36"W return shell. Model H107313K has one lock, which secures two of the three doors. For task light and vertical paper manager, see pages 319 and 321.

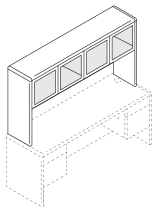
**Stack-on Storage w/Frosted Doors w/Silver Frame**

68 $\frac{5}{8}$ "W x 14 $\frac{5}{8}$ "D x 37 $\frac{1}{8}$ "H

H10734G

185

16.2

\$1836

NOTES: Rich woodgrain laminate and contemporary frosted doors with silver frames add a sleek mixed materials option to 10700 Series™. Accepts back enclosure model H10738, for use with back enclosure model H90034, task light HH870960 and vertical paper manager HVLPM1. Frosted door models are non-locking.

NOTES:

- Shared components on this page can be used with modular, full pedestal, and 3/4 pedestal models shown on pages 300-309.
- Stack-on storage models are equipped with self closing, adjustable hinged doors, and valance to hide task light.
- When spanning the total depth of an L-workstation, stack-on storage attaches to the desk, peninsula or corner unit via double-sided tape, and to the return through the grommet hole.
- Stack-on storage end panels are
- Stack-on storage and organizers attach with two removable mounting brackets, except for "L" workstation unit.
- Stacked paper management segments and organizes stack-on storage compartments and bookcase shelves. Unit can be used in stack-on storage models H107318 and H10734. See HLVP2 on page 319.
- Vertical paper manager keeps papers, files, and books neatly organized and within easy reach from a seated position. Fits under stack-on storage models. See page 319.

See pages 310-322 for shared components.

Upcharges may apply to premium fabric grades.

Removable lock core kit for locking stack-on storage is model HF27B. See page 853.

HOW TO SPECIFY

Select Model Number	Select Laminate
	See page 293
H 1 0 7 3 4 .	N N



10700 SERIES™

Shared Components and Accessories

	DESCRIPTION	MODEL	COM	SHIP WEIGHT	CUBE	LIST PRICE
 18 5/8" H	Back Enclosure for Stack-on Storage					
	72 1/4" W - for 74 5/8" W model #H107318/H107318K	H107358		34	1.3	\$273
	66 1/4" W - for 68 5/8" W model #H10734/H10734K	H10738		31	1.3	\$251
	60 1/4" W - for 62 5/8" W model #H10733/H10733K	H10737		29	1.3	\$233
	54 1/4" W - for 56 5/8" W model #H10732/H10732K	H10736		27	1.3	\$223
	42 1/4" W - for 44 5/8" W model #H107313/H107313K	H107353		22	0.9	\$223
	NOTES: Non-tackable. Specify laminate. Features full width 1 1/8" slot at bottom to facilitate routing cords and reaching wall electrical outlets. H10738 can also be used with H10634 and H94234 stack-ons.					
 18" H	for use with Stack-on Back Enclosures (Back Enclosures must be ordered separately.)					
	71 1/2" W - for 74 5/8" W model #H107318/H107318K Hutch with #H107358 Enclosure	H90035	2.0	13	2.8	\$326
	65 1/4" W - for 68 5/8" W model #H10734/H10734K Hutch with #H10738 Enclosure	H90034	2.0	11	2.0	\$310
	59 1/4" W - for 62 5/8" W model #H10733/H10733K Hutch with #H10737 Enclosure	H90033	2.0	10	1.8	\$295
	53 1/4" W - for 56 5/8" W model #H10732/H10732K Hutch with #H10736 Enclosure	H90032	2.0	9	1.8	\$259
	41 1/2" W - for 44 5/8" W model #H107313/H107313K Hutch with #H107353 Enclosure	H90031	2.0	7	1.7	\$248
	NOTES: are sized 3/4" narrower than respective stack-on storage back enclosure, allowing 3/8" each side to route task light cords. Specify fabric selection from pages 25-26. Board is attached using latch & hook tape provided. H90034 can also be used with H10738 on H10634 and H94234 stack-ons.					
	<p>! Disperse (DISP) fabric not available on sizes wider than 60".</p> <p>SPECIFYING EXAMPLE: H90035.APN15</p>					

NOTES:

- Shared components on this page can be used with modular, full pedestal, and 3/4 pedestal models shown on pages 300-309.
- Stacked paper management segments and organizes stack-on storage compartments and bookcase shelves. Unit can be used in stack-on storage models H107318 and H10734. See HLVP2 on page 319.
- Vertical paper manager keeps papers, files, and books neatly organized and within easy reach from a seated position. Fits under stack-on storage models. See page 319.

! See pages 310-322 for shared components.

Upcharges may apply to premium fabric grades.

HOW TO SPECIFY

Select Model Number H 1 0 7 3 5 8 .	Select Laminate See page 293 N
---	---





10700 SERIES™

Shared Components and Accessories

GSA SIN 33721

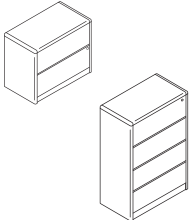
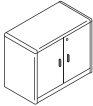
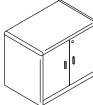
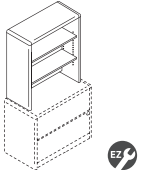

Icon Legend on page 19

	DESCRIPTION	MODEL	SHIP WEIGHT	CUBE	LIST PRICE
	Box/Box/File Mobile Pedestal (with core removable lock) 15 ³ / ₄ "W x 22 ³ / ₄ "D x 28 ⁵ / ₈ "H — use freestanding or under 24"D, 30"D and 36"D modular shells NOTES: Top box drawer does not lock. File drawer includes hangrails.	H105102	121	8.5	\$854
	File/File Mobile Pedestal (with core removable lock) 15 ³ / ₄ "W x 22 ³ / ₄ "D x 28 ⁵ / ₈ "H — use freestanding or under 24"D, 30"D and 36"D modular shells NOTES: File drawers include hangrails.	H105104	121	8.4	\$854
	Box/File Mobile Pedestal (with core removable lock) 15 ³ / ₄ "W x 18 ¹ / ₈ "D x 21 ¹ / ₈ "H — use freestanding or under 20"D, 24"D, 30"D and 36"D modular shells	H105106	65	5.8	\$714
 <i>Mobile pedestals have smooth, flat edges.</i>	Shelf/Box/File Mobile Pedestal (with core removable lock) 15 ³ / ₄ "W x 18 ¹ / ₈ "D x 28 ⁵ / ₈ "H — use freestanding or under 20"D, 24"D, 30"D and 36"D modular shells NOTES: Interior dimensions of the open storage area of the Shelf/Box/File model are 14 ¹ / ₈ "W x 16 ³ / ₄ "D x 6 ⁵ / ₈ "H.	H105109	73	7.3	\$786
	Lateral File (with core removable lock) 36"W x 24"D x 29 ¹ / ₂ "H — two drawer — matches depth of credenzas and returns 36"W x 20"D x 29 ¹ / ₂ "H — two drawer 36"W x 20"D x 45 ¹ / ₂ "H — three drawer 36"W x 20"D x 59 ¹ / ₈ "H — four drawer NOTES: Includes hangrails, mechanical interlock and, in H10762 and H107690, a counterweight. Interlock inhibits the extension of more than one drawer from opening at a time. 24"D size aligns evenly with 24"D credenzas, credenza shells, returns, return shells, and wardrobe/storage cabinets to provide linear layout continuity.	H107690 H10762 H107698 H107699	191 168 240 296	18.6 15.6 23.2 31.0	\$1206 \$1161 \$1787 \$2466
	Storage Cabinet with Doors (with core removable lock) 36"W x 20"D x 29 ¹ / ₂ "H NOTES: One adjustable interior shelf.	H107291	144	15.0	\$940
	Storage Cabinet with Doors (with core removable lock) 36"W x 24"D x 29 ¹ / ₂ "H — matches depth of credenzas and returns NOTES: One adjustable interior shelf. 24"D size aligns evenly with 24"D credenzas, credenza shells, returns, return shells, and wardrobe/storage cabinets to provide linear layout continuity.	H107290	162	18.6	\$1034
	Bookcase Hutch 32 ⁵ / ₈ "W x 14 ⁵ / ₈ "D x 37 ¹ / ₈ "H NOTES: For use with Lateral Files (H10762, H107690) and Storage Cabinets (H107291, H107290). Cord pass-through gap behind shelves and a 1 ¹ / ₈ " full-width cord management slot at the bottom of the back panel to facilitate routing cords and reaching wall electrical outlets. When placed on a 29 ¹ / ₂ "H base unit, the total 66 ⁵ / ₈ "H matches the height of credenzas with stack-on storage and the height of the wardrobe/storage cabinet. Two shelves are adjustable in 1 ¹ / ₄ " increments.	H107292	93	5.1	\$697

NOTES:

- Shared components on this page can be used with modular, full pedestal, and 3/4 pedestal models shown on pages 300-309.
- Broad family of storage components takes organization way beyond the confines of a desk drawer.
- Mobile pedestal tops have smooth, flat edges. Units are standard with counterweight and four 2" diameter, non-locking casters.
- Locking units equipped with interchangeable core removable locks.
- Mobile pedestals, lateral files, storage cabinets, and bookcases ship assembled.
- See pages 310-322 for shared components.

! Keyed alike cores must be ordered separately — see model HF23B on page 853 — makes re-keying quick and easy.

HOW TO SPECIFY

Select Model Number	Select Laminate
See page 293	See page 293
H 1 0 5 1 0 2 .	N N

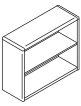

10700 SERIES™ Shared Components and Accessories

	DESCRIPTION	MODEL	SHIP WEIGHT	CUBE	LIST PRICE
	Bookcase w/Fixed Shelves				
	36"W x 13 1/8"D x 71"H, 5-Shelf	H10755	187	25.3	\$1035
	36"W x 13 1/8"D x 57 1/8"H, 4-Shelf	H10754	156	20.3	\$875
	36"W x 13 1/8"D x 43 3/8"H, 3-Shelf	H10753	122	15.6	\$777
	36"W x 13 1/8"D x 29 5/8"H, 2-Shelf	H10752	90	10.9	\$644
	NOTES: 36"W models with finished back. No assembly required. Ready to set in place.				

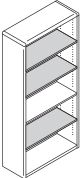
	Bookcase w/Adjustable Shelves				
	32 3/8"W x 13 1/8"D x 71"H, 5-Shelf	H107569	170	25.1	\$1022
	NOTES: 32 3/8"W design with five shelves; two fixed, three adjustable. Shelves adjust in 2 1/2" increments. Finished back.				

Shaded shelves are adjustable.

NOTES:

- Shared components on this page can be used with modular, full pedestal, and 3/4 pedestal models shown on pages 300-309.
- Broad family of storage components takes organization way beyond the confines of a desk drawer.
- Conventional bookcase designs ship fully assembled to ease and speed installation.
- See pages 310-322 for shared components.

HOW TO SPECIFY

Select Model Number	Select Laminate
	See page 293
H 1 0 7 5 2 .	N N

10700 SERIES™

Shared Components and Accessories

GSA SIN 33721



Icon Legend on page 19



Doors open 110 degrees from closed position.

DESCRIPTION**MODEL****SHIP WEIGHT****CUBE****LIST PRICE****Storage Cabinet (with core removable lock)**36"W x 24"D x 66⁵/₈"H**H107299**

341

41.0

\$2275

NOTES: Large storage area includes five, full-width (side-to-side) shelves; three are adjustable in 2¹/₂" increments. Unit height is designed to match credenza or return plus stack-on height (66⁵/₈").

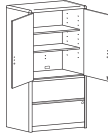

Doors open 110 degrees from closed position.

Storage Cabinet/Lateral File (with core removable lock)36"W x 24"D x 66⁵/₈"H**H107293**

365

41.0

\$2501

NOTES: Storage cabinet is standard with one fixed and two full-width adjustable shelves in top compartment; adjustable shelves can be removed. Overall storage compartment measures 31¹/₄"W x 22"D x 36¹/₈"H and will accommodate supplies, books and binders, as well as business machines and electronic equipment. Cord pass-through gap behind shelves and grommet in back of the cabinet to facilitate routing cords and reaching wall electrical outlets. Two drawer lateral file on bottom. Cabinet and lateral file lock independently.

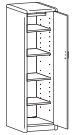

Right-hand model H107295R shown.

Wardrobe/Storage Cabinet (with core removable lock)18"W x 24"D x 66⁵/₈"H, with coat rod and 4 adjustable shelves, Hinged Right**H107295R**

225

22.9

\$183918"W x 24"D x 66⁵/₈"H, with coat rod and 4 adjustable shelves, Hinged Left**H107296L**

225

22.9

\$1839

NOTES: Unit is standard with four adjustable shelves, coat rod, and core removable lock. Shelves adjust in 2¹/₂" increments. Unit height is designed to match credenza or return plus stack-on storage height. Cabinet can be used as a wardrobe by removing four adjustable shelves. Coat rod can be removed from cabinet for storage only applications.

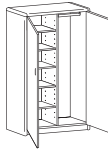

Doors open 110 degrees from closed position.

Personal Wardrobe/Storage Cabinet (with core removable lock)36"W x 24"D x 66⁵/₈"H**H10730**

335

40.6

\$2485

NOTES: Spacious design is standard with four adjustable shelves (one shelf is fixed), coat rod and core removable lock which locks both doors. Shelves adjust in 2¹/₂" increments. Unit height is designed to match credenza or return plus stack-on storage height.

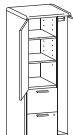

Right-hand model H107301R shown.

Personal Storage Towers24"W x 24"D x 66⁵/₈"H, Wardrobe Hinged Right, Storage Cabinet Hinged Left**H107301R**

299

27.8

\$236024"W x 24"D x 66⁵/₈"H, Wardrobe Hinged Left, Storage Cabinet Hinged Right**H107302L**

299

27.8

\$2360

NOTES: Spacious design includes a wardrobe closet, storage cabinet, and two file drawers in one compact unit. Wardrobe closet contains a coat rod. Storage cabinet includes three shelves, two are adjustable in 2¹/₂" increments. Door hinged left or right models available. File drawers operate on ball-bearing suspensions with full extension. File drawers have high sides to accept hanging folders in letter or legal size. Drawers standard with hangrails. Equipped with interchangeable core removable locks. Upper lock secures storage cabinet and wardrobe closet doors; lower lock secures file drawers. Unit height is designed to match credenza or return plus stack-on storage height.

NOTES:

- Broad family of storage components takes storage way beyond the confines of a desk drawer.
- The 18"W wardrobe/storage cabinet can be used as wardrobe by removing some or all of the adjustable shelves, coat rod can be removed for storage only.
- Locking units equipped with interchangeable core removable locks.
- See pages 310-322 for shared components.

! Keyed alike cores must be ordered separately — see model HF23B on page 853 — makes re-keying quick and easy.

HOW TO SPECIFY**Select Model Number**

H 1 0 7 2 9 3 .

Select Laminate









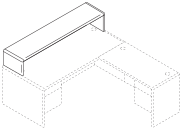

See page 293

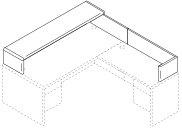
N N

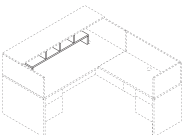

10700 SERIES™

Shared Components and Accessories

	DESCRIPTION	MODEL	SHIP WEIGHT	CUBE	LIST PRICE
 	Reception Station/Transaction Counter 68 $\frac{5}{8}$ "W x 14 $\frac{5}{8}$ "D x 14 $\frac{1}{4}$ "H Intended for use with H10700 72"W double and single pedestal desk models and 72"W desk shells. NOTES: Cord management grommets on desktops serve as anchor points. Transaction counter organizer (HTCOL52) fits under/inside of transaction counter.	H107720	76	3.2	\$677
 	Reception Station for an "L" Workstation 68 $\frac{5}{8}$ "W x 75 $\frac{1}{2}$ "D x 14 $\frac{1}{4}$ "H Intended for use with a 72"W x 36"D left single pedestal desk or modular desk shell with a 42"W x 24"D right pedestal return or modular right return shell. Intended for use with a 72"W x 36"D right single pedestal desk or modular desk shell with a 42"W x 24"D left pedestal return or modular left return shell. NOTES: Cord management grommets on desktop and return serves as the anchor points for the reception station for return.	H107721R	108	4.3	\$974
 	Transaction Counter Organizer 48 $\frac{3}{4}$ "W x 11 $\frac{1}{8}$ "D x 13"H Fits under Transaction Counter Models H107720, H107721R and H107722L.  Black only. SPECIFYING EXAMPLE: HTCOL52.P	HTCOL52	24	1.1	\$283
 <p>Base sold separately.</p> 	42" Diameter Table Top NOTES: Underside of top features a factory-installed template. The template, which is trilingual, facilitates assembly of the base to the top by designating the specific attachment location for multiple base designs. Bases attach to the top with self drilling screws, no drilling is required. All top + base models are 29 $\frac{1}{2}$ "H. For Base Options see Preside® Table Base pages 776-779.  Requires specification of a support base model shown on pages 776-779. SPECIFYING EXAMPLE: H107242.N	H107242	58	4.1	\$651

NOTES:

- "L" Reception station includes components for both the reception/transaction counter for desk and the reception station for return.
- Round table design is well suited to a variety of applications, including use in private or open plan offices.
- See pages 310-322 for shared components.

HOW TO SPECIFY

Select Model Number H 1 0 7 7 2 0	Select Laminate See page 293 N N
---	---

10700 SERIES™

Shared Components and Accessories

GSA SIN 33721

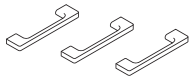
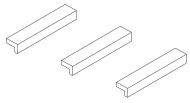

Icon Legend on page 19

**DESCRIPTION****MODEL****SHIP WEIGHT****CUBE****LIST PRICE****Field Installable Drawer/Door Handle Kits**

Linear, Black, 2-pack

HLINEARA20.4 **Ⓢ**

0.3

\$56

Linear, Matte Chrome, 2-pack

HLINEARC20.4 **Ⓢ**

0.3

\$56

Linear, Black, 3-pack

HLINEARA30.5 **Ⓢ**

0.3

\$64

Linear, Matte Chrome, 3-pack

HLINEARC30.5 **Ⓢ**

0.3

\$64

Specify Linear handles in black to coordinate with 10700 or 10500 Series™ models that ship standard with a decorative handle, such as mobile pedestals, storage cabinets and wardrobes.

Arch, Black, 2-pack

HARCHA20.4 **Ⓢ**

0.3

\$56

Arch, Matte Chrome, 2-pack

HARCHC20.4 **Ⓢ**

0.3

\$56

Arch, Black, 3-pack

HARCHA30.5 **Ⓢ**

0.3

\$64

Arch, Matte Chrome, 3-pack

HARCHC30.5 **Ⓢ**

0.3

\$64

NOTES: Handles are for purchase and field installation on 10700 or 10500 Series™ desks, credenzas, returns, lateral files and modular pedestals. Instructions include mounting hardware and paper template for drilling holes.

Applications include:

- box/file and file/file pedestals = one 2-pack per pedestal
- box/box/file and pencil/media/file pedestals = one 3-pack per pedestal
- two drawer lateral file = two 2-packs per unit
- four drawer lateral file = four 2-packs per unit

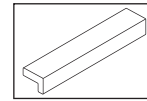
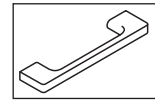
**Linear Handle****Arch Handle**

The Linear and Arch handles can be attached using 96mm (approx. 3¾") or 128mm (approx. 5") hole spacing. Important note: effective January 1, 2007, the holes used for the black drawer/door handle that comes standard on several HON 10700 or 10500 Series™ products, including mobile pedestals, storage cabinet with doors, storage/file cabinet, storage cabinet/lateral file, personal wardrobe/storage cabinets, and personal storage towers, will accept the Linear and Arch handles. Units manufactured prior to January 1, 2007, have 64mm (approx. 2½") hole spacing and will not accept the Linear and Arch handles.

! **Must be ordered with a configurable end product. If ordered separately, not on GSA contract.**

**Field Installable Drawer/Door Handle Kits**

Sweep Black, 2-pack

HSWEEPA20.4 **Ⓢ**

0.3

\$43

Sweep Satin Nickel, 2-pack

HSWEEPC20.4 **Ⓢ**

0.3

\$43

Sweep Black, 3-pack

HSWEEPA30.5 **Ⓢ**

0.3

\$56

Sweep Satin Nickel, 3-pack

HSWEEPC30.5 **Ⓢ**

0.3

\$56

Crescent Black, 2-pack

HCRESCENTA20.4 **Ⓢ**

0.3

\$43

Crescent Satin Nickel, 2-pack

HCRESCENTC20.4 **Ⓢ**

0.3

\$43

Crescent Black, 3-pack

HCRESCENTA30.5 **Ⓢ**

0.3

\$56

Crescent Satin Nickel, 3-pack

HCRESCENTC30.5 **Ⓢ**

0.3

\$56

NOTES: Handles are for purchase and field installation on 10700 or 10500 Series™ desks, credenzas, returns, and lateral files, as well as for the modular pedestals used with 10700 and 10500.

Applications include:

- box/file and file/file pedestals = one 2-pack per pedestal
- box/box/file and pencil/media/file pedestals = one 3-pack per pedestal
- two drawer lateral file = two 2-packs per unit
- four drawer lateral file = four 2-packs per unit

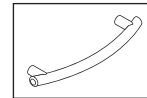
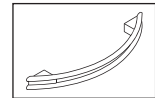
**Sweep Handle****Crescent Handle**

The hole spacing for the Sweep and Crescent handles is 96mm (approx. 3¾"). Important note: effective January 1, 2007, the holes used for the black drawer/door handle that comes standard on several HON 10700 or 10500 Series™ products, including mobile pedestals, storage cabinet with doors, storage/file cabinet, storage cabinet/lateral file, personal wardrobe/storage cabinets, and personal storage towers, will accept the Sweep and Crescent handles. Units manufactured prior to January 1, 2007, have 64mm (approx. 2½") hole spacing and will not accept the Sweep and Crescent handles. Instructions include mounting hardware and paper template.

! **Must be ordered with a configurable end product. If ordered separately, not on GSA contract.**

NOTES:

- Field Installable Drawer/Door Handle Kits for use on 10700 Series™ desks, credenzas, returns, lateral files and storage cabinets.
- A metal template is available to facilitate field installation of the Linear, Arch, Sweep and Crescent decorative handles on 10500 and 10700 Series™ drawer fronts; order model SPLH-SYST-DRKNB.M263164.
- See pages 310-322 for shared components.

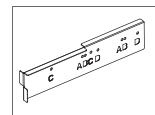

**Metal Template****HOW TO SPECIFY**

Select
Model Number

H L I N E A R A 2

10700 SERIES™

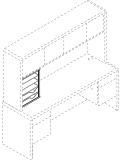
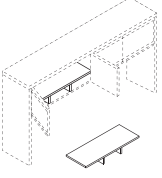
Shared Components and Accessories

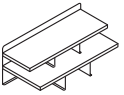
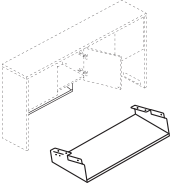
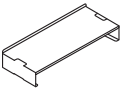
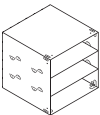
	DESCRIPTION	MODEL	SHIP WEIGHT	CUBE	LIST PRICE
	Vertical Paper Manager 14 ⁷ / ₈ "W x 10 ⁷ / ₈ "D x 19 ¹ / ₁₆ "H NOTES: Keeps papers, files, and books neatly organized and within easy reach from a seated position. Designed for desk, credenza, and return tops. Fits under stack-on storage models. Two pullout drawers and three fixed shelves. Vertical paper manager designed for desk, credenza, and return tops. Fits under stack-on storage. For additional information see page 844.	HLVPM1	27	2.8	\$327
	Stacked Paper Management 32 ¹ / ₂ "W x 12 ⁵ / ₈ "D x 4 ¹ / ₄ "H NOTES: Segments and organizes stack-on and wall mount storage compartments, as well as bookcase shelves. In some cases, installation may require removing the stack-on or wall mount storage doors. For additional information see page 845.  Black only.	HLVPM2	22	1.25	\$163
	Desktop Storage Terrace 26 ¹ / ₂ "W x 12 ¹ / ₂ "D x 10 ¹ / ₂ "H NOTES: Keeps work-in-process, priority files, loose pages, and mail neatly organized and in view. Mixed material design comprised of sturdy laminate shelves with metal back and support panels. Not available in two-tone laminate combination or pattern laminate colors. Choose from Platinum Metallic (T1), Black (P), and Charcoal (S) for the metal components. Sized to fit in stack-on and wall mounted storage cabinets in 10500, 10700, Valido, 94000, and 38000 Series. Fits in Voi stack-on and overhead cabinets except for 48"W or smaller sliding door models. For additional information see page 844. Specify: Model.Laminate.Paint SPECIFYING EXAMPLE: HLDST1.N.T1	HLDST1	24	1.1	\$306
	Hanging Paper Shelf 28 ¹ / ₁₆ "W x 11 ⁷ / ₁₆ "D x 4 ⁵ / ₁₆ "H NOTES: Maximizes worksurface space; de-clutters desktop while placing priority communications and active project folders within easy reach. Angled design allows contents to be distinguished at a glance. Mixed material styling features strong painted metal frame with a frosted shelf. Attaches quickly and easily to stack-on and wall mount storage models in the following series: 10500, 10700, Valido, 94000, and Voi (except the 36"W overhead hutch with O-legs or panel mount brackets). Not for use with 38000 Series. For additional information see page 824. Specify: Model.Paint SPECIFYING EXAMPLE: HHPS1.T1	HHPS1	7	2.9	\$198
	Desktop Paper Shelf 28 ¹ / ₁₆ "W x 11 ⁵ / ₁₆ "D x 5"H NOTES: Organizer shelf provides a place and space for work-in-process and piling to keep worksurfaces neat and tidy. Convenient, scalable design with interlocking side supports allow two units to be stacked and integrated. Durable painted metal frame with a frosted shelf; mixed material styling matches hanging paper shelf. Can also be used inside select overhead storage, including the following stack-on with hinged door models: 10500 and Valido 36", 42", 66", 72", 78"W and 10700 68 ⁵ / ₁₆ "W. For additional information see page 824. Specify: Model.Paint SPECIFYING EXAMPLE: HDPS1.T1	HDPS1	7	2.9	\$198
	Storage Cube 12"W x 12"D NOTES: For additional information see page 846. SPECIFYING EXAMPLE: HLSSL1212.P8S	HLSSL1212	1	0.3	\$294

NOTES:

- See pages 310-322 for shared components.

HOW TO SPECIFY

Select Model Number H L V P M 1 . N	Select Laminate See page 293
---	--









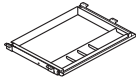

10700 SERIES™

Shared Components and Accessories

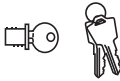
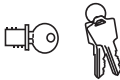
OPEN MARKET EXCEPT AS NOTED

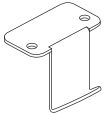

Icon Legend on page 19

	DESCRIPTION	MODEL	SHIP WEIGHT	CUBE	LIST PRICE
 Refer to page 106 for Center Drawer compatibility information SIN 33721	Angled Wood Center Drawer 26" x 15 ³ / ₈ " 22" x 15 ³ / ₈ "	H1526 H1522	12.0  11.0 	1.2 1.1	\$198 \$184
	NOTES: Center drawers ideal for pens, pencils and other miscellaneous storage. Feature ball-bearing slide suspension. Compatibility (where to use) information is detailed on page 106. Specify laminate for drawer. Model H1522 or H1022 can be used on peninsulas with modesty panel, model H10528. For additional information see page 832.				
	Polymer Center Drawer <ul style="list-style-type: none"> Color: Black. Material: ABS. Opening Requirements: 23"W x 16¹/₄"D x 2"H. Retracts on 16" ball-bearing slides. Can be used on worksurfaces with Coordinate™ Height Adjustable Bases as long as it is attached with spacer model HKBS. Can store up to 25 lbs. NOTES: For additional information see page 833.  Black finish only, no specification needed.	HCD1	7.0	0.5	\$108
 SIN 33721	Black Removable Lock Core Kit — see page 853. NOTES: Lock with a removable cylinder that can be interchanged as needed; allows users to access all furniture pieces in an office with a single key for convenience and security. Makes re-keying quick and easy.	HF23B	0.1	0.1	\$32
 	Removable Lock Core Kit Black <ul style="list-style-type: none"> For stack-on and wall mounted storage laminate models (with locks) in 10500, 10700, Valido, Voi, Concinity, and 94000 Series. Specify quantity of each key number from 101E to 225E. Includes: 1-core, 2-keys, 1-core removal tool, and instructions. NOTES: If key number isn't specified, number will be at random.	HF27B	0.2	0.02	\$32
 	Back Pack Hook (10 per carton) 12"W x 14 ¹ / ₂ "D x 1 ¹ / ₂ "H NOTES: Assembly: attaches to bottom of desk with (2) screws, included. For additional information see page 846.  Available in Platinum Metallic finish only, no specification needed.	HCLA65	10.0 	0.1	\$94

NOTES:

- For master key, see model HF22 on page 853.
- See pages 310-322 for shared components.

HOW TO SPECIFY

Select Model Number H 1 5 2 6 .	Select Laminate See page 293 N N
---	---

10700 SERIES™

Shared Components and Accessories



Refer to pages 829-831 for additional product information

SIN 33721



DESCRIPTION	MODEL	SHIP WEIGHT	CUBE	LIST PRICE BY PAINT GRADE	
				P1	P2
Sit to Stand Arm with Convertible Keyboard Platform	H2516 OPEN MARKET *	17 Ⓔ	1.6	\$618	
Articulating Arm with Convertible Keyboard Platform	H2107 OPEN MARKET *	16 Ⓔ	1.3	\$529	
Articulating Arm with Keyboard Platform	H1706 OPEN MARKET *	16 Ⓔ	1.4	\$493	
Slide-Away Keyboard Platform (Specify: Laminate)	H4022	10 Ⓔ	0.6	\$213	
Extended Tray Slide-Away Keyboard Platform (Specify: Laminate)	HE4022	12 Ⓔ	0.7	\$302	
Metal Keyboard and Mouse Tray (Specify paint)	H4028 OPEN MARKET	11 Ⓔ	1.5	\$153	\$163
Metal Keyboard Tray (Specify paint)	H4029 OPEN MARKET	11 Ⓔ	1.5	\$138	\$148
Corner Sleeve — Square Edge (22½" leading edge x 18"D) Specify paint color.	H51206	10 Ⓔ	1.5	\$155	\$165

NOTES: For additional information see pages 829-831.



SIN 33721

DESCRIPTION	MODEL	SHIP WEIGHT	CUBE	LIST PRICE
LED Task Lights				
Articulating Desk Lamp	HLED1	1.2 Ⓔ	6.5	\$402
Articulating Desk Lamp w/ Occupancy Sensor	HLED1OC	1.2 Ⓔ	6.5	\$490

NOTES: For additional information see page 841.



SIN 33721

Task Desk Lamp	HLED2	0.7 Ⓔ	3.0	\$348
-----------------------	--------------	--------------	-----	--------------

NOTES: For additional information see page 841.

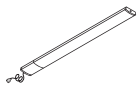

OPEN MARKET

LED Task Lights — for Stack-on Storage Models				
17" LED Light with Power Supply (Single)	HLED17AS	1.2 Ⓔ	0.05	\$420
31" LED Light with Power Supply (Single)	HLED31AS	1.5 Ⓔ	0.09	\$565
17" LED Light with Power Supply for Daisy-chain (Starter)	HLED17A	1.0 Ⓔ	0.05	\$462
31" LED Light with Power Supply for Daisy-chain (Starter)	HLED31A	1.4 Ⓔ	0.09	\$620
17" LED Light with 8" and 30" Jumper Cord for Daisy-chain (Follower)	HLED17AUO	1.0 Ⓔ	0.03	\$377
31" LED Light with 8" and 30" Jumper Cord for Daisy-chain (Follower)	HLED31AUO	1.0 Ⓔ	0.05	\$502
Undercabinet Occupancy Sensor with 1" End to End Connector	HLEDOSA	0.2 Ⓔ	0.01	\$89

NOTES: To use the daisy chain application, must start with model HLED17A or HLED31A. No finish specification required. Attaches magnetically to underside of overhead storage, or attaches with provided screws or double-sided tape. Occupancy sensor attaches to a single or starter LED light and will automatically turn the light off after no motion is detected for 30 minutes. Just like all the LED light models, the occupancy sensor features a soft-touch on/off switch. LED task lights have a lifetime of 30,000 hours and have a dimmer feature that allows the user to adjust the amount of light output. For additional information see page 842.

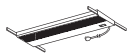

Refer to page 842

OPEN MARKET

Task Light — for Stack-on Storage Models				
46½"W x 3⅜"D x 1⅞"H, for models H107318, H10734, H10733 or H10732	HH870960	12.0 Ⓔ	1.1	\$270
34⅝"W x 3⅜"D x 1⅞"H, for model H107313	HH870942	10.0 Ⓔ	0.9	\$250

NOTES: Task light and Chicago Code models see page 545. For additional information see page 842.

NOTES:

- Task lights are designed for use with stack-on storage and wall mounted storage cabinets.
- Task lights feature a new slim profile and electronic ballast for increased energy efficiency.
- Task lights include a T5 bulb which contains less mercury.

* De-emphasized.

10700 SERIES™

Shared Components and Accessories

GSA SIN 33721T EXCEPT AS NOTED

ABI

Icon Legend on page 19



SIN 33721

DESCRIPTION**MODEL****SHIP WEIGHT****CUBE****LIST PRICE****Field Installable Grommet****HFLDGRMT**

0.1 Ⓢ

0.01

\$32

- Intended for use in tops and end panels to route/hide cords and in modesty panels to facilitate reaching wall electrical outlets.
- Grommet is field installable.
- Grommet shape is round.
- Includes grommet cap and sleeve.
- Grommet cap measures 3" diameter and includes a 3/4" diameter cord access hole.
- Grommet sleeve measures 2 1/2" O.D. x 3/4" thick.
- Includes instructions to locate grommet position for desks, credenzas, returns and bridges.

! Black Finish

! Requires a 2 1/2" diameter hole saw and drill for installation (not included).



SIN 33721

Field Installable Grommet**HFLDGRMT3**

0.1 Ⓢ

0.3

\$32

- Intended for use in tops and end panels to route/hide cords and in modesty panels to facilitate reaching wall electrical outlets.
- Grommet is field installable.
- Grommet shape is round.
- Includes grommet cap and sleeve.
- Grommet outside dimensions measure 3 1/2" diameter and includes two cord access holes.
- Grommet sleeve measures 3" O.D. x 1" thick.
- Includes instructions to locate grommet position for desks, credenzas, returns and bridges.

! Black Finish

! Requires a 3" diameter hole saw and drill for installation (not included).

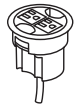
**Power Hub, 3" Grommet Mount, 6' Cord****HGRMTAC**

1.3

0.2

\$111

- Two grounded AC power outlets.
- Two cord pass-through holes in cap.
- Includes 6' cord with three-prong plug.

! Available in Black only (no color designation - Specify: HGRMTAC.X).

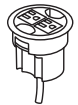

EZ

3" Round Power Grommet - 2 Outlets, 10' Cord**HGRMTAC2**

1.5

0.2

\$148

- Includes 10' cord with three-prong plug.
- Fits in 3" round grommet holes on the following product lines: Coordinate, Huddle, Motivate, all laminate and veneer casegoods series, and Systems Worksurfaces.
- Two grounded AC power outlets.
- Field installed with Plug-and-play ease.

NOTES: Power Modules will also work with standing-height applications for 10500 Series™ and Voi® desks. Optional Memory Control allows preset worksurface heights for consistency. Ships separately. Dynamic load capacity when worksurface is moving is 300 lbs.

! Available in black finish only, no specification needed.

**Power/USB Hub, 3" Grommet Mount****HGRMTUSB2**

1.3 Ⓢ

0.02

\$224

- One grounded AC power outlet with 2 USB ports.
- Two cord pass-through holes in cap.
- Includes 6' cord with three-prong plug.

! Available in black only (no color designation so use .X - Specify: HGRMTUSB2.X).

NOTES:

- The power and power/USB hub models bring the ease of plug-and-play to the desktop.
- Models HFLDGRMT3, HGRMTAC, and HGRMTUSB2 fit in 3" round grommet holes in 10700 Series™ desks, credenzas, and returns; not compatible with 10700 products with rectangle-shaped grommets.
- For additional information see page 848.

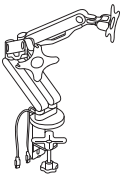
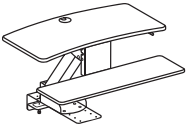
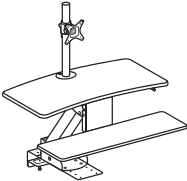
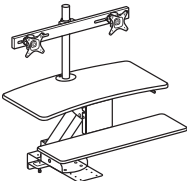
	DESCRIPTION	MODEL	SHIP WEIGHT	CUBE	LIST PRICE
	<p>Coordinate™ Portable Desktop Riser 31"D x 5"-16½"H x 35"W</p> <p>NOTES: Available in Black (BLK) or White (WHT) finish. Desktop riser dimensions (without keyboard tray): 22"D x 5"-16½"H x 35"W. Keyboard tray dimensions: 9"D x 30"W. Max loading capacity is 33 lbs for the desktop riser surface and 4 lbs for the keyboard tray. Easily transition from seated to standing positions throughout the workday. Sits atop an existing desk to create sit-to-stand functionality by raising the computer. Includes keyboard tray and surface for computer monitors. HON 5-Year Limited Warranty.</p> <p>ⓘ Not intended for use on mobile workstations.</p>	HBXRISER	54.0	4.1	\$619
	<p>Dual Monitor Arm with 2 USB Ports</p> <p>NOTES: Easy adjustment. Height adjusts to 17" tall. Monitor tilt and swivel capability. Enclosed cable management. Grommet or desktop mounting. Clean appearance. In some applications the Monitor Arms may extend 12 or more inches into the worksurface. For additional information see page 825. HON 5-Year Limited Warranty.</p> <p>ⓘ No specification needed.</p>	HBDMAUSB	41.9	2.6	\$441
	<p>Coordinate™ Mounted Desktop Riser</p> <p>NOTES: Does not include a monitor arm and is suitable for laptops and/or monitors on their original stands.</p> <p>ⓘ No specification needed.</p>	HS1100	60.0 ⓘ	3.2	\$664
	<p>Coordinate™ Mounted Desktop Riser with Single Monitor Arm</p> <p>NOTES: Includes a monitor arm for a single monitor.</p> <p>ⓘ No specification needed.</p>	HS1101	62.0 ⓘ	3.2	\$777
	<p>Coordinate™ Mounted Desktop Riser with Dual Monitor Arm</p> <p>NOTES: Includes a monitor arm for dual monitors.</p> <p>ⓘ No specification needed.</p>	HS1102	63.0 ⓘ	3.2	\$883

NOTES FOR HS1100, HS1101, HS1102:

- These products are designed to allow the user to transition from seating position to standing position throughout the workday.
- Gas-assist lever-operated mechanism with positive stop.
- Clamp mount compatible with worksurfaces depths of 20"-30". 20" is for systems only.
- Clamp requires 3.5" of clearance along back edge of worksurface.
- Black seamless worksurfaces.
- Silver powder coated metal components.
- Lowers below worksurface level on 24" and 30"D worksurfaces.
- All models contain a large primary worksurface and a smaller keyboard / mouse surface.
- Beveled edges for sleek appearance and comfort while typing.
- Monitor arms include height, width, and swivel adjustment.
- For additional information see page 838.

- Not for use under overhead storage, with flush mounted modesty panels, or worksurfaces thinner than 1".

ⓘ Not recommended for use on mobile (castered) worksurfaces.

MOUNTING AND COMPATIBILITY FOR HS1100, HS1101, HS1102:

- This product is intended to be installed on commercial-grade worksurfaces in good condition.
- Compatible with freestanding worksurfaces 24"-30"D or panel-supported worksurfaces 24"-30"D.
- Not for use on mobile worksurfaces.

Clamp Mount

Use when 3.5" minimum overhang is available

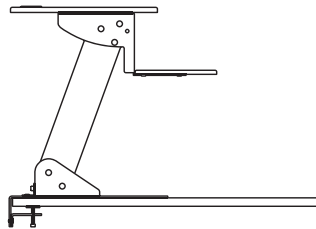

Screw Mount

Use when no overhang is available. Worksurface must be minimum 1" thick.

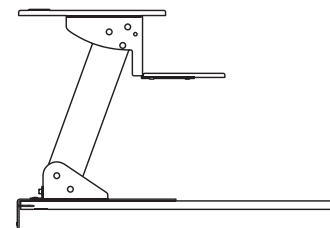

HOW TO SPECIFY

<p>Select Model Number</p> <p>HBXRISER.</p>	<p>Select Finish</p> <p>BLK Black WHT White</p> <p>BLK</p>
--	---



10700 SERIES™

Accessories

OPEN MARKET

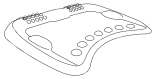
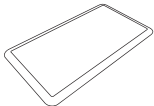
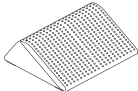

Icon Legend on page 19

	DESCRIPTION	MODEL	SHIP WEIGHT	CUBE	LIST PRICE
	Rectangle Wobble Board — Anti-Fatigue Mat 18"D x 3"H x 22½"W ⓘ Available in Black (T) finish ONLY. Recommended weight capacity not to exceed 250 pounds. HON 5-Year Limited Warranty. SPECIFYING EXAMPLE: HVL981.T	HVL981	10.0 Ⓢ	0.9	\$120
	Round Wobble Board — Anti-Fatigue Mat 18½"D x 2½"H x 18½"W ⓘ Available in Black (T) finish ONLY. Recommended weight capacity not to exceed 250 pounds. HON 5-Year Limited Warranty. SPECIFYING EXAMPLE: HVL982.T	HVL982	5.8 Ⓢ	0.6	\$102
	Ergonomic Anti-Fatigue Mat 25"D x 2¾"H x 29⅞"W ⓘ Available in Black ONLY. No specification needed. SPECIFYING EXAMPLE: HBEAFM1	HBEAFM1	7.0	1.4	\$219
	Rectangle Anti-Fatigue Mat 20"D x ¾"H x 36"W ⓘ Available in Black ONLY. No specification needed. SPECIFYING EXAMPLE: HBAFM2036	HBAFM2036	5.4	0.4	\$100
	Footrest — Anti-Slip Cover 13¾"D x 5½"H x 16"W ⓘ Available in Black (T) finish ONLY. Recommended weight capacity not to exceed 250 pounds. HON 5-Year Limited Warranty. SPECIFYING EXAMPLE: HVL991.T	HVL991	7.0 Ⓢ	0.9	\$82

HOW TO SPECIFY

Select
Model Number

H V L 9 8 1 .

Select
Finish

T Black

T

94000 SERIES™



94000 Series™ shown with 6550 Series Seating.

94000 SERIES™

Confident. Accomplished. Your office speaks volumes about you, and the 94000 Series says all the right things. Exceptionally crafted and solidly engineered, it's finished with warm, durable mahogany laminate — a timeless example of classic beauty and executive elegance.



FEATURES

- Traditional furniture design features solid wood trim and plinth style bases.
- From gleaming brass fixtures to raised accent moldings, details make this desk a standout.
- Our comprehensive selection makes it easy to create a complete executive look.
- It's all about the amenities — like pull out writing surfaces for extra room when you need it and central locking center drawers on all desks.

94000 SERIES™

Typicals



Icon Legend on page 19

Components used are listed on pages 328-333. Order components individually. Other configurations are possible, including various sizes of some components.

QTY	DESCRIPTION	MODEL	LIST PRICE	PRICE EXTENSION
1	Double Pedestal Desk 72"W x 36"D x 29½"H	H94271	\$2,467	\$2,467
1	Credenza with Kneespace 72"W x 24"D x 29½"H	H94243	\$2,059	\$2,059
1	Stack-on Storage 70"W x 16⅞"D x 37"H	H94234	\$1,485	\$1,485
TOTAL:			\$6,011	

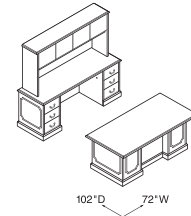

DESK WORKSTATION
72"W x 102"D

QTY	DESCRIPTION	MODEL	LIST PRICE	PRICE EXTENSION
1	Double Pedestal Desk 72"W x 36"D x 29½"H	H94271	\$2,467	\$2,467
1	Credenza with Doors 72"W x 24"D x 29½"H	H94244	\$2,378	\$2,378
1	Hutch with Wire Mesh Doors 70"W x 16⅞"D x 48¾"H	H94235	\$2,759	\$2,759
TOTAL:			\$7,604	

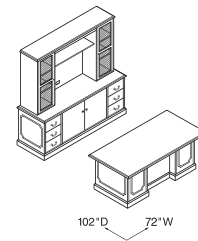

DESK WORKSTATION
72"W x 102"D

QTY	DESCRIPTION	MODEL	LIST PRICE	PRICE EXTENSION
1	Laminate Rectangle Top with Traditional Edge Detail 72"W x 36"D	HTLC3672T	\$1,091	\$1,091
1	Laminate Traditional Panel Base 29½"H with HTLC3672T Top	HTLT72	\$763	\$763
1	Credenza with Doors 72"W x 24"D x 29½"H	H94244	\$2,378	\$2,378
1	Stack-on Storage 70"W x 16⅞"D x 37"H	H94234	\$1,485	\$1,485
TOTAL:			\$5,717	

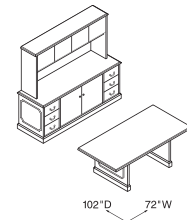
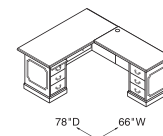

TABLE WORKSTATION
72"W x 102"D

QTY	DESCRIPTION	MODEL	LIST PRICE	PRICE EXTENSION
1	Single Pedestal Desk, Left 66"W x 30"D x 29½"H	H94284L	\$2,028	\$2,028
1	Right Return – box/file 48"W x 24"D x 29½"H	H94215R	\$1,385	\$1,385
TOTAL:			\$3,413	



DESK "L" WORKSTATION – RIGHT
66"W x 78"D



Icon Legend on page 19

94000 SERIES™ Typicals

Components used are listed on pages 328-333. Order components individually. Other configurations are possible, including various sizes of some components.

QTY	DESCRIPTION	MODEL	LIST PRICE	PRICE EXTENSION
1	Single Pedestal Desk, Right 66"W x 30"D x 29½"H	H94283R	\$2,028	\$2,028
1	Left Return - box/file 48"W x 24"D x 29½"H	H94216L	\$1,385	\$1,385
1	Stack-on-Storage 76"W x 16⅞"D x 37"H	H94237	\$1,545	\$1,545
TOTAL:			\$4,958	

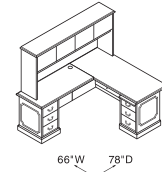

DESK "L" WORKSTATION - LEFT
66"W x 78"D

QTY	DESCRIPTION	MODEL	LIST PRICE	PRICE EXTENSION
1	Single Pedestal Desk, Left 72"W x 36"D x 29½"H	H94286L	\$2,158	\$2,158
1	Bridge 48"W x 24"D x 29½"H	H94270	\$814	\$814
1	Single Pedestal Credenza, Right 72"W x 24"D x 29½"H	H94245R	\$1,779	\$1,779
1	Stack-on Storage 70"W x 16⅞"D x 37"H	H94234	\$1,485	\$1,485
TOTAL:			\$6,236	

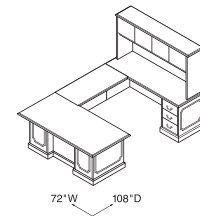

DESK "U" WORKSTATION - RIGHT
72"W x 108"D

QTY	DESCRIPTION	MODEL	LIST PRICE	PRICE EXTENSION
1	Single Pedestal Desk, Right 72"W x 36"D x 29½"H	H94285R	\$2,158	\$2,158
1	Bridge 48"W x 24"D x 29½"H	H94270	\$814	\$814
1	Credenza w/Lateral, Left 72"W x 24"D x 29½"H	H94248L	\$2,022	\$2,022
1	Stack-on Storage w/Glass Doors 70"W x 16⅞"D x 37"H	H94236	\$1,985	\$1,985
TOTAL:			\$6,979	

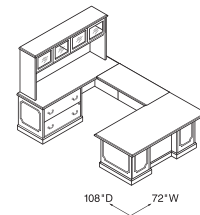

DESK "U" WORKSTATION - LEFT
72"W x 108"D

94000 SERIES™

Laminate Wood Desks

GSA SIN 33721

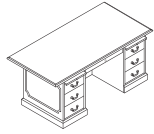

Icon Legend on page 19

**DESCRIPTION****Double Pedestal Desk 2-2 — Box/File**

72"W x 36"D x 29½"H

7"

H94271

307

52.9

\$2467

NOTES: 7" conference overhang on approach side (provides kneespace for visitors), and a 6¾" conference overhang on each end. Convenient pull out writing shelf above pedestal provides added workspace. Center drawer features central locking (locks all drawers).

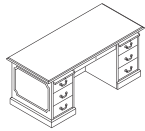
**Double Pedestal Desk 2-2 — Box/File**

66"W x 30"D x 29½"H

1"

H94276

340

42.8

\$2403

60"W x 30"D x 29½"H

1"

H94251

284

39.0

\$2321

NOTES: Convenient pull out writing shelf above pedestal provides added workspace. Center drawer features central locking (locks all drawers).

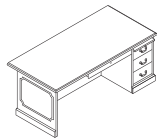
**Single Pedestal Desk — Box/File**

72"W x 36"D x 29½"H, Right

7"

H94285R

275

54.0

\$2158

66"W x 30"D x 29½"H, Right

1"

H94283R

233

42.8

\$2028

72"W x 36"D x 29½"H, Left

7"

H94286L

275

54.0

\$2158

66"W x 30"D x 29½"H, Left

1"

H94284L

233

42.8

\$2028

NOTES: Convenient pull out writing shelf above pedestal provides added workspace. Center drawer features central locking (locks all drawers).

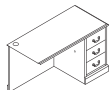

Model H94215R shown

Return — Box/File

48"W x 24"D x 29½"H, Right

H94215R

154

24.9

\$1385

42"W x 24"D x 29½"H, Right

H94211R

146

22.1

\$1283

48"W x 24"D x 29½"H, Left

H94216L

154

24.9

\$1385

42"W x 24"D x 29½"H, Left

H94212L

146

22.1

\$1283

NOTES: Drawers lock. One round cord grommet in the top. One cord pass-through grommet in the modesty panel to facilitate reaching wall electrical outlets.

⚠ Not designed to be used freestanding.

NOTES:

- 18th century elegance, 21st century engineering.
- Traditional furniture applications include state and local government, military bases, banks, and attorney offices.
- Tops are premium abrasion- and stain-resistant high pressure, high-gloss laminate over durable 1½" solid core high-performance particleboard.
- Solid wood edge profile.
- Antique brass drawer pulls; hand-applied raised decorative molding, and plinth style base.
- Pullout reference/writing shelf is standard on all desk pedestals.
- Desk, credenza, and return drawers are 5-sided construction, which allows easy drawer alignment or replacement of drawer fronts.
- Center drawer on desks equipped with built-in pencil tray and central locking (locks all drawers).
- Drawers operate on full extension, ball-bearing suspensions to ensure smooth, quiet, long-lasting operation.
- File drawer design includes integrated hangrails for side-to-side letter or legal filing; and front-to-back for letter filing.
- Locking units equipped with interchangeable core removable locks.
- 94000 Series™ products produced after 10/26/98 have been improved with a thicker top. Joining with older products before that date may cause misalignment.
- Adjustable hex leveling glides allow floor-standing furniture to be easily leveled without lifting the unit; glides have ¾" adjustable range.



⚠ Keyed alike cores must be ordered separately — see model HF23B on page 853 — makes re-keying quick and easy.

HOW TO SPECIFY

Select Model Number	Select Laminate
H 9 4 2 7 1	NN Mahogany
	NN

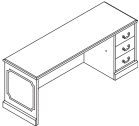
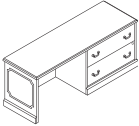
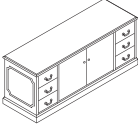
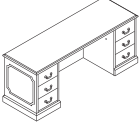

94000 SERIES™ Laminate Wood Desks

	DESCRIPTION	MODEL	SHIP WEIGHT	CUBE	LIST PRICE
 	Bridge (single ped. desk to single ped. credenza or credenza with lateral) 48"W x 24"D x 29½"H, (clear inside depth is 22½"D) 42"W x 24"D x 29½"H, (clear inside depth is 22½"D)	H94270 H94260	85 76	4.3 4.3	\$814 \$752
	NOTES: One cord pass-through grommet in top center of modesty panel to facilitate reaching wall electrical outlets. Kneespace of desk is limited to 24¾"W if bridge is used with 66"W single pedestal desk.				
 Model H94245R shown	Credenza, Single Pedestal — Box/File 72"W x 24"D x 29½"H, Right 72"W x 24"D x 29½"H, Left	H94245R H94246L	230 230	36.0 36.0	\$1779 \$1779
	NOTES: Drawers lock. One cord pass-through grommet in top center of modesty panel to facilitate reaching wall electrical outlets. See pages 330-331 for optional Overhead Hutch and Stack-on Storage.				
 Model H94247R shown	Credenza with 36" Lateral 72"W x 24"D x 29½"H, Right 72"W x 24"D x 29½"H, Left	H94247R H94248L	239 239	36.0 36.0	\$2022 \$2022
	NOTES: Lateral file drawers lock. See pages 330-331 for optional Overhead Hutch and Stack-on Storage.				
 Model H94244 shown	Credenza with Doors — Box/File 72"W x 24"D x 29½"H	H94244	313	36.0	\$2378
	NOTES: All drawers lock. Doors are non-locking. One removable shelf (38¾"W x 13¾"D). Shelf is not adjustable. See pages 330-331 for optional Overhead Hutch and Stack-on Storage.				
 Model H94243 shown	Credenza with Kneespace — Box/File 72"W x 24"D x 29½"H	H94243	253	36.0	\$2059
	NOTES: All drawers lock. One cord pass-through grommet in top center of modesty panel to facilitate reaching wall electrical outlets. See pages 330-331 for optional Overhead Hutch and Stack-on Storage.				

NOTES:

- 18th century elegance, 21st century engineering.
- Tops are premium abrasion- and stain-resistant high pressure, high-gloss laminate over durable 1½" solid core high-performance particleboard.
- Solid wood edge profile.
- Antique brass drawer pulls; hand-applied raised decorative molding, and plinth style base.
- Pullout reference/writing shelf is standard on all desk pedestals.
- Desk, credenza, and return drawers are 5-sided construction, which allows easy drawer alignment or replacement of drawer fronts.
- Center drawer on desks equipped with built-in pencil tray and central locking (locks all drawers).
- Drawers operate on full extension, ball-bearing suspensions to ensure smooth, quiet, long-lasting operation.
- File drawer design includes integrated handrails for side-to-side letter or legal filing; and front-to-back for letter filing.
- Locking units equipped with interchangeable core removable locks.
- 94000 Series™ products produced after 10/26/98 have been improved with a thicker top. Joining with older products before that date may cause misalignment.
- Adjustable hex leveling glides allow floor-standing furniture to be easily leveled without lifting the unit; glides have ¾" adjustable range.

ⓘ Keyed alike cores must be ordered separately — see model HF23B on page 853 — makes re-keying quick and easy.

HOW TO SPECIFY

Select Model Number <input type="text" value="H"/> <input type="text" value="9"/> <input type="text" value="4"/> <input type="text" value="2"/> <input type="text" value="4"/> <input type="text" value="5"/> <input type="text" value="R"/>	Select Laminate <input type="text" value="NN"/> Mahogany
--	--

94000 SERIES™

Laminate Wood Desks

GSA SIN 33721

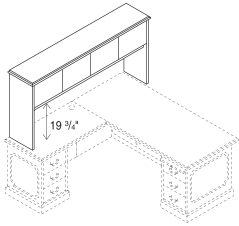

Icon Legend on page 19

**DESCRIPTION****Stack-on Storage for 78" D "L" Shaped Workstation**

76"W x 16 $\frac{1}{8}$ "D x 37"H (Accepts Back Enclosure H107358, Fabric H90035 and Task Light HH870960.)

MODEL**H94237****SHIP WEIGHT**

198

CUBE

18.4

LIST PRICE**\$1545****Stack-on Storage for 78" D "L" Shaped Workstation, Locking**

76"W x 16 $\frac{1}{8}$ "D x 37"H (Accepts Back Enclosure H107358, Fabric H90035 and Task Light HH870960.)

H94237K

198

18.4

\$1629

NOTES: Spans the total dimension of "L" shaped layouts comprised of a 48"W return attached to a 30"D single pedestal desk (78"D); or a 42"W return attached to 36"D single pedestal desk (78"D). For vertical paper manager model HLVPM1, see page 333.

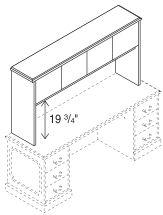
**Stack-on Storage**

70"W x 16 $\frac{1}{8}$ "D x 37"H (Accepts Back Enclosure H10738, Fabric H90034 and Task Light HH870960.)

H94234

175

18.0

\$1485**Stack-on Storage, Locking**

70"W x 16 $\frac{1}{8}$ "D x 37"H (Accepts Back Enclosure H10738, Fabric H90034 and Task Light HH870960.)

H94234K

175

18.0

\$1568

NOTES: For use on 72"W credenza models or on 72"D "L" shaped workstations comprised of a 30"D single pedestal desk and a 42"W return. Inside storage contains two compartments each sized: 31 $\frac{3}{4}$ "W x 12 $\frac{1}{8}$ "D x 12"H. Vertical paper manager, model HLVPM1, fits under stack-on storage. See page 333.

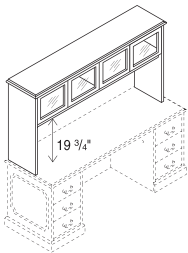
**Stack-on Storage with Glass Doors**

70"W x 16 $\frac{1}{8}$ "D x 37"H (Accepts Back Enclosure H10738 and Fabric H90034.) (Use Task Light HH870960, see page 331)

H94236

171

18.0

\$1985

NOTES: Elegant wood-framed, clear glass door design. For use on 72"W credenza models or on 72"D "L" shaped workstations comprised of a 30"D single pedestal desk and a 42"W return. No lock option for glass doors. For vertical paper manager model HLVPM1, see page 333.

NOTES:

- Stack-on storage equipped with self-closing, adjustable hinged doors.
- Stack-on storage design includes valance to hide task light.
- Vertical paper manager keeps papers, files and books organized and within easy reach from a seated position. Fits under stack-on storage models. See page 333.
- Stacked paper management segments and organizes stack-on storage compartments and bookcase shelves. Unit can be used in models H94327, H94234 and H94236. In some cases, installation may require removing the stack-on storage doors. See page 319.
- For a variety of work-in-process paper management tools, see pages 282-283.
- Overhead Hutch features one cord pass-through grommet located in bottom center of back panel.
- Overhead Hutch is not designed to accept task light.
- Removable lock core kit for locking stack-on storage is model HF27B. See page 853.

HOW TO SPECIFY**Select Model Number**

H 9 4 2 3 7 .

Select Laminate



NN Mahogany

N N

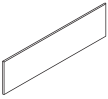

Icon Legend on page 19

94000 SERIES™ Laminate Wood Desks

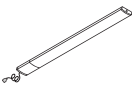
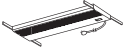
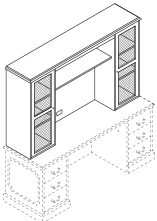
	DESCRIPTION	MODEL	COM	SHIP WEIGHT	CUBE	LIST PRICE
 <p>18⁵/₈"H</p>	Back Enclosure for Stack-on Storage 76"W model #H94237 70"W model #H94234 or H94236 NOTES: Specify laminate with a single designator. Non-tackable surface. Feature full width 1 ¹ / ₈ " slot at bottom to facilitate routing cords and reaching wall electrical outlets. SPECIFYING EXAMPLE: H107358.N	H107358		34.0	1.30	\$273
		H10738		31.0	1.30	\$251
 <p>18"H</p>	for use with Stack-on Storage Back Enclosures (Back Enclosures must be ordered separately.) 71 ¹ / ₂ "W for 76"W model #H94237 Stack-on with #H107358 Enclosure 65 ¹⁵ / ₁₆ "W for 70"W model #H94234 or H94236 Stack-on with #H10738 Enclosure NOTES: Specify fabric selection from pages 25-26. Upcharges may apply to premium fabric grades. are sized ³ / ₄ " narrower than respective stack-on storage back enclosure, allowing ³ / ₈ " each side to route task light cords. Attached to back enclosure using latch & hook tape provided. ! Disperse (DISP) fabric not available on sizes wider than 60". SPECIFYING EXAMPLE: H930035.APN15	H90035	2.0	13.0	2.80	\$326
		H90034	2.0	11.0	2.00	\$310
 <p>OPEN MARKET</p>	LED Task Lights — For Stack-on and Wall Mounted Storage Cabinets 17" LED Light with Power Supply (Single) 31" LED Light with Power Supply (Single) NOTES: No finish specification required. Attaches magnetically to underside of overhead storage, or attaches with provided screws or double-sided tape. Occupancy sensor attaches to a single or starter LED light and will automatically turn the light off after no motion is detected for 30 minutes. Just like all the LED light models, the occupancy sensor features a soft-touch on/off switch. LED task lights have a lifetime of 50,000 hours and have a dimmer feature that allows the user to adjust the amount of light output. For additional information see page 842.	HLED17AS		1.2	0.05	\$420
		HLED31AS		1.5	0.09	\$565
 <p>Refer to page 842 OPEN MARKET</p>	Recessed Task Light 46 ¹ / ₂ "W x 3 ¹ / ₁₆ "D for Models H94234, H94234K, H94236, H94237 and H94237K. Chicago code version (with fused plug) NOTES: For additional information see page 842.	HH870960		12.0	1.10	\$270
		HH870960CH		12.0	1.10	\$337
	Overhead Hutch w/Wire Mesh Doors 70"W x 16 ¹ / ₈ "D x 48 ³ / ₄ "H NOTES: Each side storage compartment contains: 1-lower opening 16 ¹ / ₄ "W x 13 ¹ / ₁₆ "D x 15 ⁷ / ₈ "H and 2-upper openings 16 ¹ / ₄ "W x 13 ¹ / ₁₆ "D x 14 ³ / ₈ "H. Clearance for computer, etc.: 32 ³ / ₁₆ "W x 12 ⁵ / ₈ "D x 31 ³ / ₄ "H. No lock option for mesh doors. ! 14 ³ / ₄ "H center shelf does not adjust. Not designed to accept task light.	H94235		260.0	43.30	\$2759

NOTES:

- Stack-on storage equipped with self-closing, adjustable hinged doors.
- Stack-on storage design includes valance to hide task light.
- Vertical paper manager keeps papers, files and books organized and within easy reach from a seated position. Fits under stack-on storage models. See page 333.
- Stacked paper management segments and organizes stack-on storage compartments and bookcase shelves. Unit can be used in models H94237, H94234 and H94236. In some cases, installation may require removing the stack-on storage doors. See page 319.
- For a variety of work-in-process paper management tools, see pages 282-283.
- Overhead Hutch features one cord pass-through grommet located in bottom center of back panel.
- ! Overhead Hutch is not designed to accept task light.
- ! Removable lock core kit for locking stack-on storage is model HF27B. See page 853.

HOW TO SPECIFY

Select Model Number H 9 4 2 3 5 .	Select Laminate NN Mahogany
---	---------------------------------------



94000 SERIES™

Laminate Wood Desks

GSA SIN 33721

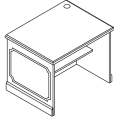
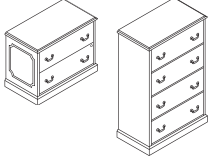
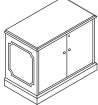
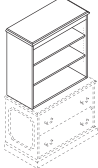
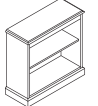

Icon Legend on page 19

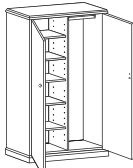
	DESCRIPTION	MODEL	SHIP WEIGHT	CUBE	LIST PRICE
	Computer Work Table with cord grommet 36"W x 30"D x 29½"H NOTES: One removable shelf (32⅓½"W x 12⅝"D).	H94226	130	23.8	\$1123
	Lateral Files (with core removable lock) 37½"W x 20½"D x 29½"H — two drawer 37½"W x 20½"D x 59½"H — four drawer NOTES: High capacity file storage. Includes hangrails; mechanical interlock inhibits the extension of more than one drawer at a time. Two drawer design is equipped with a counterweight.	H94223 H94229	172 300	17.7 34.0	\$1421 \$2438
	Storage Cabinet (with core removable lock) 37½"W x 20½"D x 29½"H NOTES: Bookcase hutch H94210 can be used with H94291. One adjustable shelf, adjusts in 1¼" increments.	H94291	165	16.7	\$1274
	Bookcase Hutch 35¾"W x 14⅝"D x 37"H, (3 shelves; 2 adjustable, includes bottom of unit) Designed to be used on model H94223 lateral file or model H94291 storage cabinet. NOTES: One cord pass-through grommet located at bottom center of back panel. Two adjustable shelves, adjust in 1¼" increments.	H94210	95	14.0	\$952
	Bookcase 35¾"W x 14⅝"D x 35½"H, 2-Shelf 35¾"W x 14⅝"D x 49⅝"H, 3-Shelf 35¾"W x 14⅝"D x 64"H, 4-Shelf 35¾"W x 14⅝"D x 78¼"H, 5-Shelf NOTES: Fixed shelves.	H94221 H94222 H94224 H94225	100 130 160 200	14.8 20.6 26.3 32.3	\$889 \$996 \$1130 \$1239
	Bookcase with Glass Doors 35¾"W x 14⅝"D x 49⅝"H NOTES: Upscale design brings order, utility and a touch of elegance to the traditional office. Wood-framed, clear glass doors with hinges provide easy access to interior. Three fixed shelves provide spacious storage. Shelf measures 32¾"W x 11¾"D. Bookcase with glass doors brings order, utility and a touch of elegance to the traditional office. ! Doors are not designed to lock.	H94220	155	20.6	\$1588
	Storage Cabinet/Lateral File (with core removable lock) 37½"W x 24"D x 66½"H NOTES: Standard with one fixed and two full-width adjustable shelves in top compartment; adjustable shelves can be removed. Overall storage compartment measures 33¾"W x 22"D x 36⅞"H and will accommodate supplies, books and binders, as well as business machines and electronic equipment. Cord pass-through gap behind shelves and grommet in back of the cabinet to facilitate routing cords and reaching wall electrical outlets. Two drawer lateral file on bottom. Lateral file comes with mechanical interlock and hangrails. Cabinet and lateral file lock independently. Unit height is designed to match credenza or return plus stack-on storage height or the two drawer lateral file or storage cabinet plus the bookcase hutch height (66½"H).	H94435	355	44.4	\$2599
<i>Doors open 110 degrees from closed position.</i>					
	Personal Wardrobe/Storage Cabinet (with core removable lock) 37½"W x 24"D x 66½"H NOTES: Spacious design is standard with four adjustable shelves (one shelf is fixed) plus a generous wardrobe section with a coat rod. Shelves adjust in 2½" increments. One lock secures both doors. Unit height is designed to match credenza plus stack-on storage height or the two drawer lateral file or storage cabinet plus the bookcase hutch height (66½"H). Personal wardrobe/storage cabinet is standard with four adjustable shelves (one shelf is fixed) plus a generous wardrobe section with a coat rod.	H94430	351	44.4	\$2555

NOTES:









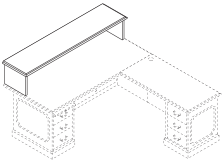

- File drawers accommodate letter and legal width side-to-side filing, and letter-width front-to-back filing; use hanging folders with a maximum overall height of 9⅜".
- Adjustable hex leveling glides allow floor-standing furniture to be easily leveled without lifting the unit; glides have ¾" adjustable range.
- For conference table options, see the Preside® table tops and bases on pages 774-779. Order edge option "T" for 94000 Desks edge compatibility.
- Removable lock core kit - HF23B - allows multiple units to be keyed alike. See page 853.

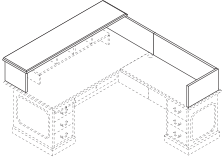
HOW TO SPECIFY

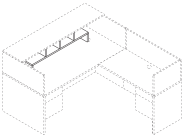
Select Model Number	Select Laminate
<input type="text" value="H"/> <input type="text" value="9"/> <input type="text" value="4"/> <input type="text" value="2"/> <input type="text" value="2"/> <input type="text" value="6"/>	<input type="text" value="NN"/>
	<input type="text" value="NN"/>

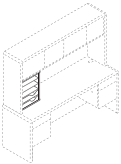

94000 SERIES™ Laminate Wood Desks

	DESCRIPTION	MODEL	SHIP WEIGHT	CUBE	LIST PRICE
 	Reception Station/Transaction Counter 71 ³ / ₄ "W x 16 ¹ / ₈ "D x 14 ¹ / ₄ "H Designed for use with 72"W single pedestal desk models H94285R or H94286L. NOTES: Reception station/transaction counter has traditional-styled decorative molding on the approach side.	H94720	75	2.6	\$927
	Reception Station for an "L" Workstation 71 ³ / ₄ "W x 82 ³ / ₄ "D x 14 ¹ / ₄ "H Designed for use with 72"W single pedestal desk H94286L and 48"W return H94215R (shown) Designed for use with 72"W single pedestal desk H94285R and 48"W return H94216L. NOTES: Reception station for "L" workstation includes components for both the reception/transaction counter for desk and the reception station for return.	H94721R H94722L	100	4.0	\$1122 \$1122
 Model H94721R shown 	Transaction Counter Organizer 48 ³ / ₄ "W x 11 ¹ / ₈ "D x 13"H Fits under Transaction Counter on models H94720, H94721R and H94722L. NOTES: Transaction Counter Organizer model HTCOL52 fits under/inside of transaction counter.  Black only. SPECIFYING EXAMPLE: HTCOL52.P	HTCOL52	24	1.1	\$283
 	Vertical Paper Manager 14 ⁷ / ₈ "W x 10 ⁷ / ₈ "D x 19 ¹ / ₁₆ "H NOTES: Keeps papers, files, and books neatly organized and within easy reach from a seated position. Designed for desk, credenza, and return tops. Fits under stack-on storage models. Two pullout drawers and three fixed shelves. NOTES: For additional information see page 844. SPECIFYING EXAMPLE: HLVPM1.N	HLVPM1	27	2.8	\$327
 Not available in two-tone laminate	Angled Wood Center Drawer 26" x 15 ³ / ₈ " 22" x 15 ³ / ₈ " NOTES: Specify laminate. For additional information see page 832. SPECIFYING EXAMPLE: H1526.N	H1526 H1522	12  11 	1.2 1.1	\$198 \$184
 Refer to page 106 for Center Drawer compatibility information					

NOTES:

- For conference table options, see the Preside® table tops and bases on pages 774-779. Order edge option "T" for 94000 Desks edge compatibility.

HOW TO SPECIFY

Select Model Number H 9 4 7 2 0	Select Laminate NN Mahogany N N
---	--

94000 SERIES™

Accessories

GSA SIN AS NOTED

ABI

Icon Legend on page 19

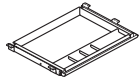

OPEN MARKET

DESCRIPTION**Polymer Center Drawer**

- Color: Black.
- Material: ABS.
- Opening Requirements: 23"W x 16¼"D x 2"H.
- Retracts on 16" ball-bearing slides.
- Can be used on worksurfaces with Coordinate™ Height Adjustable Bases as long as it is attached with spacer model HKBS.
- Can store up to 25 lbs.

NOTES: For additional information see page 833.

! Black finish only, no specification needed.

MODEL**HCD1****SHIP WEIGHT**

7.0

CUBE

0.5

LIST PRICE**\$108**

Refer to pages 829-830
for additional product
information

SIN 33721

**Sit to Stand Arm with Convertible Keyboard Platform****H2516 OPEN MARKET ***

17.0 \$

1.6

\$618**Articulating Arm with Convertible Keyboard Platform****H2107 OPEN MARKET ***

16.0 \$

1.3

\$529**Articulating Arm with Keyboard Platform****H1706 OPEN MARKET ***

16.0 \$

1.4

\$493**Slide-Away Keyboard Platform** (Specify: Laminate)**H4022**

10.0 \$

0.6

\$213**Extended Tray Slide-Away Keyboard Platform** (Specify: Laminate)**HE4022**

12.0 \$

0.7

\$302

NOTES: For additional information see pages 829-830.

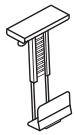

OPEN MARKET

CPU Holder

- Vertically mounts to underside of worksurface.
- 360° swivel.
- Supports up to 55 lbs.
- Height adjustable from 16" to 22" below worksurface.
- Width adjustable to accept units from 3¼" to 6".

NOTES: For additional information see page 827.

! Silver finish only, no specification needed.

HCPU *

16.0 \$

0.5

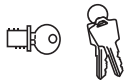
\$259

SIN 33721

**Black Removable Lock Core Kit (for laminate products)****HF23B**

0.1 \$

0.1

\$32

- Specify quantity of each key number from 101E-225E.
- Includes: 1-core, 2-keys, 1-core removal tool, and instructions.

NOTES: If key number isn't specified, number will be at random. Core matches manufactured lock on laminate product but can be used with metal casegoods product.

NOTES:

- For conference table options, see the Preside® table tops and bases on pages 774-779. Order edge option "T" for 94000 Desks edge compatibility.

* De-emphasized.

HOW TO SPECIFY

Select
Model Number

H C D 1

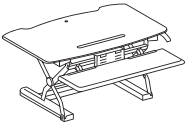
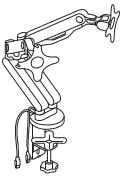
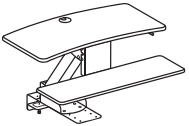
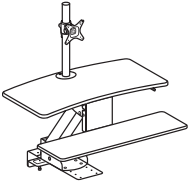
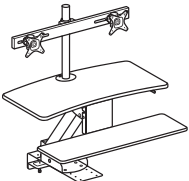
	DESCRIPTION	MODEL	SHIP WEIGHT	CUBE	LIST PRICE
	<p>Coordinate™ Portable Desktop Riser 31"D x 5"-16½"H x 35"W</p> <p>NOTES: Available in Black (BLK) or White (WHT) finish. Desktop riser dimensions (without keyboard tray): 22"D x 5"-16½"H x 35"W. Keyboard tray dimensions: 9"D x 30"W. Max loading capacity is 33 lbs for the desktop riser surface and 4 lbs for the keyboard tray. Easily transition from seated to standing positions throughout the workday. Sits atop an existing desk to create sit-to-stand functionality by raising the computer. Includes keyboard tray and surface for computer monitors. HON 5-Year Limited Warranty.</p> <p>⚠ Not intended for use on mobile workstations.</p>	HBXRISER	54.0	4.1	\$619
	<p>Dual Monitor Arm with 2 USB Ports</p> <p>NOTES: Easy adjustment. Height adjusts to 17" tall. Monitor tilt and swivel capability. Enclosed cable management. Grommet or desktop mounting. Clean appearance. In some applications the Monitor Arms may extend 12 or more inches into the worksurface. For additional information see page 825. HON 5-Year Limited Warranty.</p> <p>⚠ No specification needed.</p>	HBDMAUSB	41.9	2.6	\$441
	<p>Coordinate™ Mounted Desktop Riser</p> <p>NOTES: Does not include a monitor arm and is suitable for laptops and/or monitors on their original stands.</p> <p>⚠ No specification needed.</p>	HS1100	60.0 Ⓞ	3.2	\$664
	<p>Coordinate™ Mounted Desktop Riser with Single Monitor Arm</p> <p>NOTES: Includes a monitor arm for a single monitor.</p> <p>⚠ No specification needed.</p>	HS1101	62.0 Ⓞ	3.2	\$777
	<p>Coordinate™ Mounted Desktop Riser with Dual Monitor Arm</p> <p>NOTES: Includes a monitor arm for dual monitors.</p> <p>⚠ No specification needed.</p>	HS1102	63.0 Ⓞ	3.2	\$883

NOTES FOR HS1100, HS1101, HS1102:

- These products are designed to allow the user to transition from seating position to standing position throughout the workday.
- Gas-assist lever-operated mechanism with positive stop.
- Clamp mount compatible with worksurfaces depths of 20"-30". 20" is for systems only.
- Clamp requires 3.5" of clearance along back edge of worksurface.
- Black seamless worksurfaces.
- Silver powder coated metal components.
- Lowers below worksurface level on 24" and 30"D worksurfaces.
- All models contain a large primary worksurface and a smaller keyboard / mouse surface.
- Beveled edges for sleek appearance and comfort while typing.
- Monitor arms include height, width, and swivel adjustment.
- For additional information see page 838.

- Not for use under overhead storage, with flush mounted modesty panels, or worksurfaces thinner than 1".

⚠ Not recommended for use on mobile (castered) worksurfaces.

MOUNTING AND COMPATIBILITY FOR HS1100, HS1101, HS1102:

- This product is intended to be installed on commercial-grade worksurfaces in good condition.
- Compatible with freestanding worksurfaces 24"-30"D or panel-supported worksurfaces 24"-30"D.
- Not for use on mobile worksurfaces.

Clamp Mount

Use when 3.5" minimum overhang is available

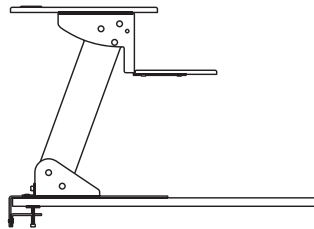

Screw Mount

Use when no overhang is available. Worksurface must be minimum 1" thick.

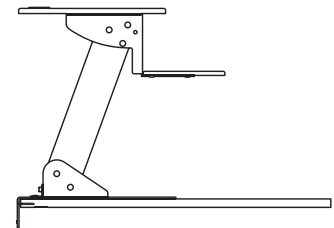

HOW TO SPECIFY

<p>Select Model Number</p> <p>HBXRISER.</p>	<p>Select Finish</p> <p>BLK Black WHT White</p> <p>BLK</p>
--	---



94000 SERIES™

Accessories

OPEN MARKET

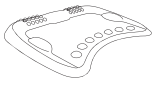
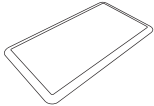
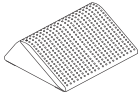

Icon Legend on page 19

	DESCRIPTION	MODEL	SHIP WEIGHT	CUBE	LIST PRICE
	Rectangle Wobble Board — Anti-Fatigue Mat 18"D x 3"H x 22½"W ⓘ Available in Black (T) finish ONLY. Recommended weight capacity not to exceed 250 pounds. HON 5-Year Limited Warranty. SPECIFYING EXAMPLE: HVL981.T	HVL981	10.0 ⓘ	0.9	\$120
	Round Wobble Board — Anti-Fatigue Mat 18½"D x 2½"H x 18½"W ⓘ Available in Black (T) finish ONLY. Recommended weight capacity not to exceed 250 pounds. HON 5-Year Limited Warranty. SPECIFYING EXAMPLE: HVL982.T	HVL982	5.8 ⓘ	0.6	\$102
	Ergonomic Anti-Fatigue Mat 25"D x 2¾"H x 29⅞"W ⓘ Available in Black ONLY. No specification needed. SPECIFYING EXAMPLE: HBEAFM1	HBEAFM1	7.0	1.4	\$219
	Rectangle Anti-Fatigue Mat 20"D x ¾"H x 36"W ⓘ Available in Black ONLY. No specification needed. SPECIFYING EXAMPLE: HBAFM2036	HBAFM2036	5.4	0.4	\$100
	Footrest — Anti-Slip Cover 13¾"D x 5½"H x 16"W ⓘ Available in Black (T) finish ONLY. Recommended weight capacity not to exceed 250 pounds. HON 5-Year Limited Warranty. SPECIFYING EXAMPLE: HVL991.T	HVL991	7.0 ⓘ	0.9	\$82

HOW TO SPECIFY

Select
Model Number

H V L 9 8 1 .

Select
Finish

T Black

T



Mentor® Double Pedestal Desk with Volt® Task Chair and Brigade® Bookcases.

MENTOR®

Users appreciate the clean lines and rounded corners of the Mentor desk from HON. Stylish detailing and soft edges create an attractive, contemporary desk that's very user-friendly. Performance and durability make Mentor ideal for use in intensive environments. Featuring central locking drawers and integrated wire management, Mentor works hard for hard-working professionals.



FEATURES

- Durable baked enamel finish will hold up beautifully under years of daily use.
- Functional features like central locking center drawers and integrated wire management.
- Sturdy steel construction and heavy-duty reinforced frames.
- Mentor's performance and durability make it ideal for intensive use environments.
- Half-round legs and radius top corners are excellent for high-traffic areas.
- Arch drawer handles match Flagship® laterals, pedestals and towers.

MENTOR® ORDERING INFORMATION

FINISHES AVAILABILITY

L1 LAMINATES CODES

Woodgrain

◆ Bourbon Cherry	H
◆ Cognac	COGN
◆ Florence Walnut	LFW1
◆ Harvest	C
◆ Kingswood Walnut	LK11
◆ Mahogany	N
◆ Mocha	MOCH
◆ Natural Maple	D
◆ Shaker Cherry	F
◆ Sterling Ash	LSA1

Solid

◆ Black	P
◆ Charcoal	S
◆ Designer White	LDW1
◆ Loft	LOFT
◆ Whitestone	K4

Patterned

◆ Sheer Mesh	A5
◆ Silver Mesh	B9
◆ Steel Mesh	A9
◇ Canyon Zephyr	K9
◇ Desert Zephyr	K8
◇ Shadow Zephyr	K1
◆ Gray	G2
◆ Grey Tigris	L6
◇ White	G1

PAINTS CODES

P1

◆ Black	P
◆ Brownstone	P7D
◆ Charcoal	S
◆ Fossil	P28
◆ Greige	T5
◆ Light Gray	Q
◆ Loft	LOFT
◆ Muslin	T3
◆ Putty	L
◆ Shadow *	SHDW
◆ Titanium	P8T

NOTE: Vinyl edge and grommets match specified chassis color.

• STEEL DESKS

SPECIFY: Model Number.
Top Laminate
Paint Color

EXAMPLE: H88976.NS

◆◆◆ For lead time information see page 19.

* De-emphasized



Icon Legend on page 19

	DESCRIPTION	MODEL	SHIP WEIGHT	CUBE	LIST PRICE
	Double Pedestal Desk with Center Drawer (6" overhang on 3 sides) — 2/2 72"W x 36"D x 29½"H, Chrome Leg and Pull NOTES: Model H88976 requires Model H386560N 60"W Stack-on as top of desk extends over end panels.	H88976	203	37.7	\$1706
	Double Pedestal Desk with Center Drawer — 2/2 60"W x 30"D x 29½"H, Chrome Leg and Pull	H88962	178	26.7	\$1413
	Single Pedestal Desk with Center Drawer – Right, box/file 66"W x 30"D x 29½"H, Chrome Leg and Pull	H88265R	162	29.2	\$1284
	Single Pedestal Desk with Center Drawer – Left, box/file 66"W x 30"D x 29½"H, Chrome Leg and Pull	H88266L	162	29.2	\$1284
	Single Pedestal Desk with Center Drawer – Right, box/file 60"W x 30"D x 29½"H, Chrome Leg and Pull	H88263R	145	26.7	\$1219
	Single Pedestal Desk with Center Drawer – Right, box/file 48"W x 30"D x 29½"H, Chrome Leg and Pull	H88251R	130	21.6	\$1155

NOTES:

- Leg available in Chrome.
- Attractive radius leg design and arched drawer pulls.
- Legs ship unattached.
- 3/4 height modesty panels.
- Rounded edge desk top with soft feel-vinyl edge.
- Wire management grommets in desk tops and pedestals.
- Laminate tops are constructed of 1½" thick particleboard.
- 13½" deep, central locking center drawer equipped with HON "One Key" interchangeable lock cores.
- High-sided file drawers accept hanging files without hangrails.
- Full extension steel ball-bearing suspensions on file drawers for easy access to all contents.
- Reinforced double "O" frame inner structure keeps desk solid and sturdy for years of use.
- Box drawers equipped with 3/4 extension steel ball-bearing suspensions and one divider.
- Vinyl edge and grommets match specified chassis color.
- All interior drawer bodies are gray, pre-painted steel.

! Keyed alike cores must be ordered separately — see page 853.

HOW TO SPECIFY

<p>Select Model Number</p> <p>H 8 8 9 7 6 .</p>	<p>Select Laminate</p> <p>See page 338</p> <p>N .</p>	<p>Select Paint Color</p> <p>See page 338</p> <p>S</p>
--	--	---



	DESCRIPTION	MODEL	SHIP WEIGHT	CUBE	LIST PRICE
	Double Pedestal Credenza with Kneespace, box/file (non-locking) 60"W x 24"D x 29½"H, Chrome Leg and Pull	H88231	149	21.8	\$1395
	Return, Right, box/file (non-locking) 42"W x 24"D x 29½"H, Chrome Leg and Pull	H88235R	92	15.5	\$897
	Return, Left, box/file (non-locking) 42"W x 24"D x 29½"H, Chrome Leg and Pull	H88236L	92	15.5	\$897

NOTES:

- Leg available in Chrome.
- Attractive radius leg design and arched drawer pulls.
- Legs ship unattached.
- ¾ height modesty panels.
- Rounded edge desk top with soft feel-vinyl edge.
- Wire management grommets in desk tops and pedestals.
- Laminate tops are constructed of 1½" thick particleboard.
- High-sided file drawers accept hanging files without hangrails.
- Full extension steel ball-bearing suspensions on file drawers for easy access to all contents.
- Reinforced double "O" frame inner structure keeps desk solid and sturdy for years of use.
- Box drawers equipped with ¾ extension steel ball-bearing suspensions and one divider.
- Vinyl edge and grommets match specified chassis color.
- All interior drawer bodies are gray, pre-painted steel.

HOW TO SPECIFY

Select
Model Number

H 8 8 2 3 1 .

Select
Laminate

See page 338

N .

Select
Paint Color

See page 338

S

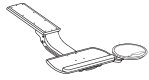

Refer to page 829 for additional product information

OPEN MARKET



DESCRIPTION

Sit to Stand Arm with Convertible Keyboard Platform
Articulating Arm with Convertible Keyboard Platform
Articulating Arm with Keyboard Platform

NOTES: For additional information see page 829.

MODEL

H2516 *
H2107 *
H1706 *

SHIP WEIGHT

17.0 **Ⓢ**
 16.0 **Ⓢ**
 16.0 **Ⓢ**

CUBE

1.6
 1.3
 1.4

LIST PRICE

\$618
\$529
\$493

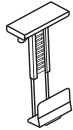

OPEN MARKET

360° Swivel CPU Holder

- Vertically mounts to underside of worksurface.
- 360° swivel.
- Supports up to 55 lbs.
- Height adjustable from 16" to 22" below worksurface.
- Width adjustable to accept units from 3¼" to 6".

NOTES: For additional information see page 827.

! Silver only

HCPU *

16.0 **Ⓢ**

0.5

\$259



Model HPWRMOD3WC shown

Power Modules

- 3 Receptacles with Worksurface Clamp
- 2 Receptacles 2 USB with Worksurface Clamp
- 6' power cord with standard three-prong plug.
- Under-worksurface mounting bracket models work with any top that has a 5" x 5" square clearance.
- Worksurface clamp models work on any top with a 4" overhang.
- UL Listed.

NOTES: For additional information see page 849.

! Color finish coordinates with HON's Charcoal or White. Specify STRM for Storm or SNW for Snow when ordering.
 Example: HPWRMOD3WC.STRM.

HPWRMOD3WC HPWRMOD2WC

2.3 **Ⓢ**
2.3 **Ⓢ**

0.2
0.2

\$307
\$491

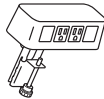

Power & Data Center

- 2 Receptacles 2 Data Accessory
- Standard with two receptacles and openings for two data ports.
- 6' power cord with standard three-prong plug.
- Fits on any worksurface with a 4" overhang.
- UL Listed.

NOTES: For additional information see page 849.

! Color finish coordinates with HON's Loft. Specify LOFT when ordering. Example: HCOMDOME2.LOFT.

HCOMDOME2

2.5 **Ⓢ**

0.2

\$293



Vertebrae

NOTES: 30"H x 3¼"W x 1½"D. Ships unassembled. For additional information see page 852.

! Clear finish. Specify "X" for finish option.

SPECIFYING EXAMPLE: HMPVWM28.X

HMPVWM28

3.0

0.3

\$221



Storage Cube

12"W x 12"D

NOTES: For additional information see page 846.

SPECIFYING EXAMPLE: HLSL1212.P8S

HLSL1212

1.0

0.3

\$294



NOTES:

* De-emphasized.

HOW TO SPECIFY

Select
Model Number

H P W R M O D 3 W C

NOTES

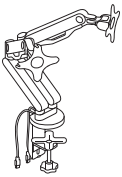
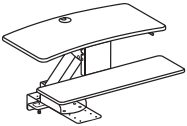
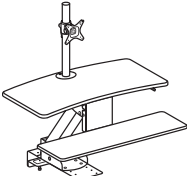
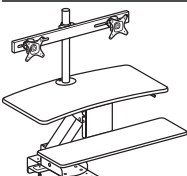
	DESCRIPTION	MODEL	SHIP WEIGHT	CUBE	LIST PRICE
	<p>Coordinate™ Portable Desktop Riser 31"D x 5'-16½"H x 35"W</p> <p>NOTES: Available in Black (BLK) or White (WHT) finish. Desktop riser dimensions (without keyboard tray): 22"D x 5'-16½"H x 35"W. Keyboard tray dimensions: 9"D x 30"W. Max loading capacity is 33 lbs for the desktop riser surface and 4 lbs for the keyboard tray. Easily transition from seated to standing positions throughout the workday. Sits atop an existing desk to create sit-to-stand functionality by raising the computer. Includes keyboard tray and surface for computer monitors. HON 5-Year Limited Warranty.</p> <p>ⓘ Not intended for use on mobile workstations.</p>	HBXRISER	54.0	4.1	\$619
	<p>Dual Monitor Arm with 2 USB Ports</p> <p>NOTES: Easy adjustment. Height adjusts to 17" tall. Monitor tilt and swivel capability. Enclosed cable management. Grommet or desktop mounting. Clean appearance. In some applications the Monitor Arms may extend 12 or more inches into the worksurface. For additional information see page 825. HON 5-Year Limited Warranty.</p> <p>ⓘ No specification needed.</p>	HBDMAUSB	41.9	2.6	\$441
	<p>Coordinate™ Mounted Desktop Riser</p> <p>NOTES: Does not include a monitor arm and is suitable for laptops and/or monitors on their original stands.</p> <p>ⓘ No specification needed.</p>	HS1100	60.0 ⓘ	3.2	\$664
	<p>Coordinate™ Mounted Desktop Riser with Single Monitor Arm</p> <p>NOTES: Includes a monitor arm for a single monitor.</p> <p>ⓘ No specification needed.</p>	HS1101	62.0 ⓘ	3.2	\$777
	<p>Coordinate™ Mounted Desktop Riser with Dual Monitor Arm</p> <p>NOTES: Includes a monitor arm for dual monitors.</p> <p>ⓘ No specification needed.</p>	HS1102	63.0 ⓘ	3.2	\$883

NOTES FOR HS1100, HS1101, HS1102:

- These products are designed to allow the user to transition from seating position to standing position throughout the workday.
- Gas-assist lever-operated mechanism with positive stop.
- Clamp mount compatible with worksurfaces depths of 20"-30". 20" is for systems only.
- Clamp requires 3.5" of clearance along back edge of worksurface.
- Black seamless worksurfaces.
- Silver powder coated metal components.
- Lowers below worksurface level on 24" and 30"D worksurfaces.
- All models contain a large primary worksurface and a smaller keyboard / mouse surface.
- Beveled edges for sleek appearance and comfort while typing.
- Monitor arms include height, width, and swivel adjustment.
- For additional information see page 838.

- Not for use under overhead storage, with flush mounted modesty panels, or worksurfaces thinner than 1".

ⓘ Not recommended for use on mobile (castered) worksurfaces.

MOUNTING AND COMPATIBILITY FOR HS1100, HS1101, HS1102:

- This product is intended to be installed on commercial-grade worksurfaces in good condition.
- Compatible with freestanding worksurfaces 24"-30"D or panel-supported worksurfaces 24"-30"D.
- Not for use on mobile worksurfaces.

Clamp Mount

Use when 3.5" minimum overhang is available

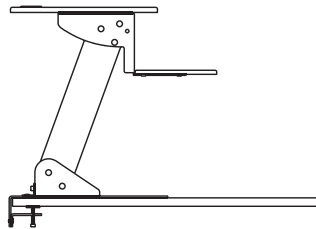

Screw Mount

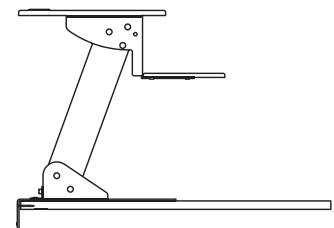

Use when no overhang is available. Worksurface must be minimum 1" thick.



HOW TO SPECIFY

<p>Select Model Number</p> <p>HBXRISER.</p>	<p>Select Finish</p> <p>BLK Black WHT White</p> <p>BLK</p>
--	---

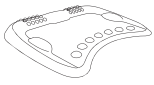
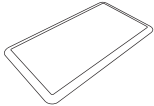
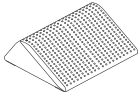

	DESCRIPTION	MODEL	SHIP WEIGHT	CUBE	LIST PRICE
	Rectangle Wobble Board — Anti-Fatigue Mat 18"D x 3"H x 22½"W ⓘ Available in Black (T) finish ONLY. Recommended weight capacity not to exceed 250 pounds. HON 5-Year Limited Warranty. SPECIFYING EXAMPLE: HVL981.T	HVL981	10.0 Ⓢ	0.9	\$120
	Round Wobble Board — Anti-Fatigue Mat 18½"D x 2½"H x 18½"W ⓘ Available in Black (T) finish ONLY. Recommended weight capacity not to exceed 250 pounds. HON 5-Year Limited Warranty. SPECIFYING EXAMPLE: HVL982.T	HVL982	5.8 Ⓢ	0.6	\$102
	Ergonomic Anti-Fatigue Mat 25"D x 2¾"H x 29⅞"W ⓘ Available in Black ONLY. No specification needed. SPECIFYING EXAMPLE: HBEAFM1	HBEAFM1	7.0	1.4	\$219
	Rectangle Anti-Fatigue Mat 20"D x ¾"H x 36"W ⓘ Available in Black ONLY. No specification needed. SPECIFYING EXAMPLE: HBAFM2036	HBAFM2036	5.4	0.4	\$100
	Footrest — Anti-Slip Cover 13¾"D x 5½"H x 16"W ⓘ Available in Black (T) finish ONLY. Recommended weight capacity not to exceed 250 pounds. HON 5-Year Limited Warranty. SPECIFYING EXAMPLE: HVL991.T	HVL991	7.0 Ⓢ	0.9	\$82

HOW TO SPECIFY

Select
Model Number

H V L 9 8 1 .

Select
Finish

T Black

T

METRO CLASSIC



Metro Classic Desk shown with Ignition® Seating.

METRO CLASSIC

The Metro Classic is a forward-thinking flashback that marries '60s styling with today's technology. This handsomely built collection offers excellent performance for the price — with best-in-class construction, easy-care laminate tops, built-in wire management and more. If you're looking for iconic style that lasts, you'll find it in Metro Classic.



FEATURES

- Retro-styled, but with up-to-date amenities, this classic reflects the enduring Modernist office designs of the 1960s.
- With tubular steel legs painted to match the desk body, Metro Classic gives you a clean look from top to bottom.
- Pedestals feature Tru-Fit mitered drawer fronts for precision alignment when closed.
- Contract-grade, multi-ply laminate stands up to scratches, spills, stains and boiling liquids.
- Recessed plastic drawer handles are color-matched to HON core paint colors.
- All drawers lock by securing the center drawer; lock core can be changed as security needs require.

METRO CLASSIC ORDERING INFORMATION

FINISHES AVAILABILITY

L1 LAMINATES/EDGE BAND

COLOR CODES

Woodgrain

- ◆ Bourbon Cherry/
Bourbon Cherry **H**
- ◆ Cognac/Cognac **COGN**
- ◆ Florence Walnut/
Florence Walnut **LFW1**
- ◆ Harvest/Harvest **C**
- ◆ Kingswood Walnut/
Kingswood Walnut **LK11**
- ◆ Mahogany/Mahogany **N**
- ◆ Mocha/Mocha **MOCH**
- ◆ Natural Maple/
Natural Maple **D**
- ◆ Shaker Cherry/
Shaker Cherry **F**
- ◆ Sterling Ash/
Sterling Ash **LSA1**

Solid

- ◆ Black/Black **P**
- ◆ Charcoal/Charcoal **S**
- ◆ Designer White/
Designer White **LDW1**
- ◆ Loft/Loft **LOFT**

Patterned

- ◆ Sheer Mesh/Muslin **A5**
- ◆ Silver Mesh/Loft **B9**
- ◆ Steel Mesh/Charcoal **A9**
- ◆ Canyon Zephyr/
Greige **K9**
- ◆ Desert Zephyr/
Greige **K8**
- ◆ Shadow Zephyr/
Loft **K1**
- ◆ Gray/Matches Paint Color **G2**
- ◆ Grey Tigris/Greige **L6**
- ◆ White/Matches Paint
Color **G1**
- ◆ Whitestone/Matches Paint
Color **K4**

PAINTS CODES

P1

- ◆ Black **P**
- ◆ Brownstone **P7D**
- ◆ Charcoal **S**
- ◆ Fossil **P28**
- ◆ Greige **T5**
- ◆ Light Gray **Q**
- ◆ Loft **LOFT**
- ◆ Muslin **T3**
- ◆ Putty **L**
- ◆ Shadow * **SHDW**
- ◆ Titanium **P8T**

• STEEL DESKS

SPECIFY: Model Number.
Top Laminate
Paint Color

EXAMPLE: HP3276.NS



◆◆◆ For lead time information see page 19.

* De-emphasized

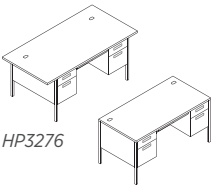
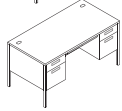

Icon Legend on page 19

METRO CLASSIC Steel Desks

	DESCRIPTION	MODEL	SHIP WEIGHT	CUBE	LIST PRICE
 <p>HP3276</p>	Double Pedestal — 2/2 (locking) 72"W x 36"D x 29½"H (6" overhang on 3 sides) NOTES: HP3276 requires Model H386560N 60"W Stack-on as top of desk extends over end panels.	HP3276	218	37.7	\$1649
	60"W x 30"D x 29½"H (Non-Locking, 24"D chassis) (6" overhang on approach side only)	HP3261	165	26.7	\$1156
	60"W x 30"D x 29½"H (locking)	HP3262	186	26.7	\$1347
 <p>HP3262</p>	Single Pedestal (locking) 66"W x 30"D x 29½"H — 2R 66"W x 30"D x 29½"H — 2L 48"W x 30"D x 29½"H — 2R	HP3265R	167	29.2	\$1244
		HP3266L	167	29.2	\$1244
		HP3251R	142	21.6	\$1109
	Return, Right — box/file (non-locking) 42"W x 24"D x 29½"H	HP3235R	95	15.5	\$871
	Return, Left — box/file (non-locking) 42"W x 24"D x 29½"H	HP3236L	95	15.5	\$871

NOTES:

- Two wire grommets in desk, credenza, and return tops.
- 3/4 height modesty panels.
- Legs shipped unattached.
- Color of pulls and grommets match paint selection for core colors.
- "Tru-fit" mitered drawer fronts for better visual alignment.
- Color of legs match paint selection.
- Central locking center drawer standard, with HON "One Key" interchangeable lock cores.
- High-sided file drawers accept hanging files without hangrails.
- Full extension steel ball-bearing suspensions on file drawers for easy access to all contents.
- Box drawers equipped with 3/4 extension steel ball-bearing suspensions and one divider.
- Reinforced, double "O" frame inner structure keeps desk solid and sturdy for years of use.
- All interior drawer bodies are gray pre-painted steel.
- 38000 Series™ stack-on units can be used on Metro desks and credenzas.

ⓘ Keyed alike cores ordered separately — see page 853.

HOW TO SPECIFY

<p>Select Model Number</p> <p>HP3276</p>	<p>Select Laminate</p> <p>See page 346 Not specified for models H386566N, H386560N and H386548N</p> <p>N</p>	<p>Select Paint Color</p> <p>See page 346</p> <p>S</p>
---	---	---

METRO CLASSIC

Steel Desks

GSA SIN 33721

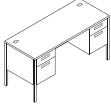
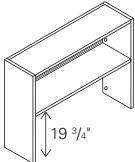
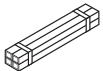
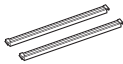

Icon Legend on page 19

	DESCRIPTION	MODEL	SHIP WEIGHT	CUBE	LIST PRICE
	Credenza w/Kneespace — 2/2 (non-locking) 60"W x 24"D x 29½"H Accommodates optional HD2 or HD8 center drawer. NOTES: Non-locking.	HP3231	165.0	21.8	\$1347
	Stack-on Full Clearance without Doors 66"W x 13½"D x 34¾"H 60"W x 13½"D x 34¾"H 48"W x 13½"D x 34¾"H NOTES: Interior is 12¾"H. Specify: Paint color. For additional 38000 Series™ Stack-on accessory items, see pages 374-376. HP3276 requires Model H386560N 60"W Stack-on as top of desk extends over end panels.	H386566N H386560N H386548N	68.0 64.0 53.0	6.3 5.7 4.7	\$861 \$798 \$728
	Chrome Leg Packs — Field Installable 4 pk-29½"H	HC14	7.2	0.2	\$128
	Double-Rail Hanging File Racks — 2 Pack (for side-to-side) ⓘ Gray only	H519495	0.5	0.5	\$33

NOTES:

- Two wire grommets in desk, credenza, and return tops.
- ¾ height modesty panels.
- Legs shipped unattached.
- Color of pulls and grommets match paint selection for core colors.
- "Tru-fit" mitered drawer fronts for better visual alignment.
- Color of legs match paint selection.
- Central locking center drawer standard, with HON "One Key" interchangeable lock cores.
- High-sided file drawers accept hanging files without hangrails.
- Full extension steel ball-bearing suspensions on file drawers for easy access to all contents.
- Box drawers equipped with ¾ extension steel ball-bearing suspensions and one divider.
- Reinforced, double "O" frame inner structure keeps desk solid and sturdy for years of use.
- All interior drawer bodies are gray pre-painted steel.
- 38000 Series™ stack-on units can be used on Metro desks and credenzas.

ⓘ Keyed alike cores ordered separately — see page 853.

HOW TO SPECIFY**Select Model Number**

HP3231

Select Laminate

See page 346

Not specified for models H386566N, H386560N and H386548N

N

Select Paint Color

See page 346

S

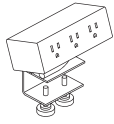

Model HPWRMOD3WC shown

DESCRIPTION**Power Modules**

3 Receptacles with Worksurface Clamp

2 Receptacles 2 USB with Worksurface Clamp

- 6' power cord with standard three-prong plug.
- Under-worksurface mounting bracket models work with any top that has a 5" x 5" square clearance.
- Worksurface clamp models work on any top with a 4" overhang.
- UL Listed.

! Color finish coordinates with HON's Charcoal or White. Specify *STRM* for Storm or *SNW* for Snow when ordering.
Example: HPWRMOD3WC.STRM.

MODEL**SHIP WEIGHT****CUBE****LIST PRICE****HPWRMOD3WC**

2.3 Ⓞ

0.2

\$307**HPWRMOD2WC**

2.3 Ⓞ

0.2

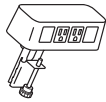
\$491**Power & Data Center**

2 Receptacles 2 Data Accessory

- Standard with two receptacles and openings for two data ports.
- 6' power cord with standard three-prong plug.
- Fits on any worksurface with a 4" overhang.
- UL Listed.

! Color finish coordinates with HON's Loft. Specify *LOFT* when ordering. Example: HCOMDOME2.LOFT.

HCOMDOME2

2.5 Ⓞ

0.2

\$293**Vertebrae**

NOTES: 30"H x 3 1/8"W x 1 1/2"D. Ships unassembled.

! Clear finish. Specify "X" for finish option.

SPECIFYING EXAMPLE: HMPVWM28.X**HMPVWM28**

3.0

0.3

\$221**NOTES:**

- For additional information see pages 849 and 852.

HOW TO SPECIFYSelect
Model Number

H P W R M O D 3 W C

NOTES

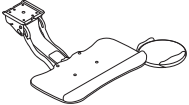
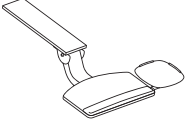
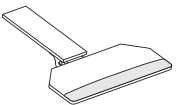
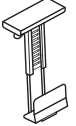
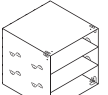

Icon Legend on page 19

	DESCRIPTION	MODEL	SHIP WEIGHT	CUBE	LIST PRICE
	<p>Sit to Stand Arm with Keyboard</p> <ul style="list-style-type: none"> • Sit to stand application. • No knob or lever for adjustment, simply lift into place. • One-hand tilt adjustment for maximum flexibility. • For use on surfaces 24" or deeper. • Height adjustment without levers. • +10°/-20° tilt adjustment. • Height adjustment 12½" (7" above and 5½" below). • Tilt and swivel mouse surface with gel palm rest. • Detachable palm rest. • Mouse pad can mount right or left. <p>NOTES: For additional information see page 829.</p> <p>! Black finish only, no specification needed.</p>	H2516 *	17 Ⓢ	1.6	\$618
	<p>Articulating Arm with Convertible Keyboard</p> <ul style="list-style-type: none"> • 21" glide track. • Lift and lock height adjustment. • Height adjustment 7" (2½" above and 4½" below track). • Release handle for independent tilt adjustment. • Tilt: +/-15°. • Independent tilt and swivel mousing platform. • Positions platform flush with worksurface. • 360° rotation. • Mouse can be used in-line, over, or forward at platform height or above. • Mouse can be placed at platform height or above height. • Left or right handed mousing; no tools required. • Detachable palm rest. • Cord management clips included. <p>NOTES: For additional information see page 829.</p> <p>! Black finish only, no specification needed.</p>	H2107 *	16 Ⓢ	1.3	\$529
	<p>Articulating Arm with Keyboard</p> <ul style="list-style-type: none"> • 17" glide track. • Spring assisted. • Height adjustment 6¼" (1¼" above and 5" below track). • Tilt: +10°/-15°. • 25" cut corner platform. • Accommodates keyboard and mouse on same level. • Detachable palm rest. • Cord management clips included. <p>NOTES: For additional information see page 829.</p> <p>! Black finish only, no specification needed.</p>	H1706 *	16 Ⓢ	1.4	\$493
	<p>CPU Holder</p> <ul style="list-style-type: none"> • Vertically mounts to underside of worksurface. • 360° swivel. • Supports up to 55 lbs. • Height adjustable from 16" to 22" below worksurface. • Width adjustable to accept units from 3¼" to 6". <p>NOTES: For additional information see page 827.</p> <p>! Silver finish only, no specification needed.</p>	HCPU *	16 Ⓢ	0.5	\$259
	<p>Storage Cube</p> <p>12"W x 12"D</p> <p>NOTES: For additional information see page 846.</p> <p>SPECIFYING EXAMPLE: HL1212.P8S</p>	HL1212	1	0.3	\$294

SIN 33721



NOTES:

* De-emphasized.

HOW TO SPECIFY

Select Model Number

H	2	5	1	6
---	---	---	---	---

METRO CLASSIC

Accessories

OPEN MARKET

Icon Legend on page 19

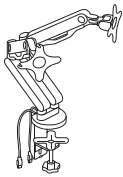
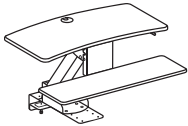
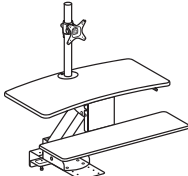
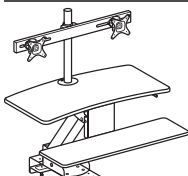
	DESCRIPTION	MODEL	SHIP WEIGHT	CUBE	LIST PRICE
	Coordinate™ Portable Desktop Riser 31"D x 5'-16½"H x 35"W NOTES: Available in Black (BLK) or White (WHT) finish. Desktop riser dimensions (without keyboard tray): 22"D x 5'-16½"H x 35"W. Keyboard tray dimensions: 9"D x 30"W. Max loading capacity is 33 lbs for the desktop riser surface and 4 lbs for the keyboard tray. Easily transition from seated to standing positions throughout the workday. Sits atop an existing desk to create sit-to-stand functionality by raising the computer. Includes keyboard tray and surface for computer monitors. HON 5-Year Limited Warranty. ⓘ Not intended for use on mobile workstations.	HBXRISER	54.0	4.1	\$619
	Dual Monitor Arm with 2 USB Ports NOTES: Easy adjustment. Height adjusts to 17" tall. Monitor tilt and swivel capability. Enclosed cable management. Grommet or desktop mounting. Clean appearance. In some applications the Monitor Arms may extend 12 or more inches into the worksurface. For additional information see page 825. HON 5-Year Limited Warranty. ⓘ No specification needed.	HBDMAUSB	41.9	2.6	\$441
	Coordinate™ Mounted Desktop Riser NOTES: Does not include a monitor arm and is suitable for laptops and/or monitors on their original stands. ⓘ No specification needed.	HS1100	60.0 ⓘ	3.2	\$664
	Coordinate™ Mounted Desktop Riser with Single Monitor Arm NOTES: Includes a monitor arm for a single monitor. ⓘ No specification needed.	HS1101	62.0 ⓘ	3.2	\$777
	Coordinate™ Mounted Desktop Riser with Dual Monitor Arm NOTES: Includes a monitor arm for dual monitors. ⓘ No specification needed.	HS1102	63.0 ⓘ	3.2	\$883

NOTES FOR HS1100, HS1101, HS1102:

- These products are designed to allow the user to transition from seating position to standing position throughout the workday.
- Gas-assist lever-operated mechanism with positive stop.
- Clamp mount compatible with worksurfaces depths of 20"-30". 20" is for systems only.
- Clamp requires 3.5" of clearance along back edge of worksurface.
- Black seamless worksurfaces.
- Silver powder coated metal components.
- Lowers below worksurface level on 24" and 30"D worksurfaces.
- All models contain a large primary worksurface and a smaller keyboard / mouse surface.
- Beveled edges for sleek appearance and comfort while typing.
- Monitor arms include height, width, and swivel adjustment.
- For additional information see page 838.

- Not for use under overhead storage, with flush mounted modesty panels, or worksurfaces thinner than 1".

- ⓘ Not recommended for use on mobile (castered) worksurfaces.

MOUNTING AND COMPATIBILITY FOR HS1100, HS1101, HS1102:

- This product is intended to be installed on commercial-grade worksurfaces in good condition.
- Compatible with freestanding worksurfaces 24"-30"D or panel-supported worksurfaces 24"-30"D.
- Not for use on mobile worksurfaces.

Clamp Mount

Use when 3.5" minimum overhang is available

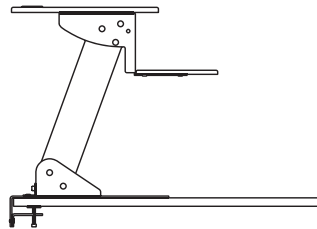

Screw Mount

Use when no overhang is available. Worksurface must be minimum 1" thick.

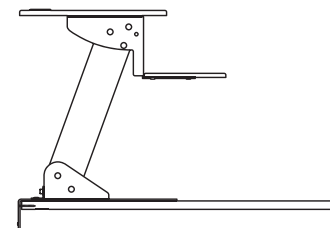



HOW TO SPECIFY

Select Model Number

Select Finish

BLK Black
WHT White

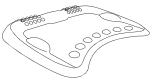
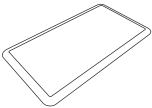
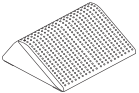

	DESCRIPTION	MODEL	SHIP WEIGHT	CUBE	LIST PRICE
	Rectangle Wobble Board — Anti-Fatigue Mat 18"D x 3"H x 22½"W ⓘ Available in Black (T) finish ONLY. Recommended weight capacity not to exceed 250 pounds. HON 5-Year Limited Warranty. SPECIFYING EXAMPLE: HVL981.T	HVL981	10.0 Ⓔ	0.9	\$120
	Round Wobble Board — Anti-Fatigue Mat 18½"D x 2⅝"H x 18½"W ⓘ Available in Black (T) finish ONLY. Recommended weight capacity not to exceed 250 pounds. HON 5-Year Limited Warranty. SPECIFYING EXAMPLE: HVL982.T	HVL982	5.8 Ⓔ	0.6	\$102
	Ergonomic Anti-Fatigue Mat 25"D x 2¾"H x 29⅞"W ⓘ Available in Black ONLY. No specification needed. SPECIFYING EXAMPLE: HBEAFM1	HBEAFM1	7.0	1.4	\$219
	Rectangle Anti-Fatigue Mat 20"D x ¾"H x 36"W ⓘ Available in Black ONLY. No specification needed. SPECIFYING EXAMPLE: HBAFM2036	HBAFM2036	5.4	0.4	\$100
	Footrest — Anti-Slip Cover 13¾"D x 5½"H x 16"W ⓘ Available in Black (T) finish ONLY. Recommended weight capacity not to exceed 250 pounds. HON 5-Year Limited Warranty. SPECIFYING EXAMPLE: HVL991.T	HVL991	7.0 Ⓔ	0.9	\$82

HOW TO SPECIFY

<p>Select Model Number</p> <p>H V L 9 8 1 .</p>	<p>Select Finish</p> <p>T Black</p> <p>T</p>
---	--

34000 SERIES



34000 Series shown with 500 Series Lateral and Volt® Seating.

34000 SERIES

The 34000 Series gets high marks in the classroom — or any environment requiring a heavy-duty metal desk that knows how to look good. The square Chrome legs and brushed Aluminum handles look clean and uncomplicated. The Tru-Fit mitered drawer fronts line up perfectly every time. Desk models offer central locking, so all the drawers can be secured with the turn of a single key. And with HON's best-in-class construction, 34000 Series will stand up to years of use.



FEATURES

- Legs are Chrome for a contemporary accent.
- Pedestals feature Tru-Fit mitered drawer fronts that align precisely when closed.
- All drawers lock by securing the center drawer; lock core can be changed as security needs require.
- Contract-grade, multi-ply laminate worksurface stands up to scratches, spills, stains and boiling liquids.
- Brushed Aluminum drawer handles match HON vertical file handles.

34000 SERIES ORDERING INFORMATION

FINISHES AVAILABILITY

L1 LAMINATES/EDGE BAND

COLOR CODES

Woodgrain

- ◆ Bourbon Cherry/
Bourbon Cherry H
- ◆ Cognac/Cognac COGN
- ◆ Florence Walnut/
Florence Walnut LFW1
- ◆ Harvest/Harvest C
- ◆ Kingswood Walnut/
Kingswood Walnut LK11
- ◆ Mahogany/Mahogany N
- ◆ Mocha/Mocha MOCH
- ◆ Natural Maple/
Natural Maple D
- ◆ Shaker Cherry/
Shaker Cherry F
- ◆ Sterling Ash/
Sterling Ash LSA1

Solid

- ◆ Black/Black P
- ◆ Charcoal/Charcoal S
- ◆ Designer White/
Designer White LDW1
- ◆ Loft/Loft LOFT

Patterned

- ◆ Sheer Mesh/Muslin A5
- ◆ Silver Mesh/Loft B9
- ◆ Steel Mesh/Charcoal A9
- ◆ Canyon Zephyr/Greige K9
- ◆ Desert Zephyr/Greige K8
- ◆ Shadow Zephyr/Loft K1
- ◆ Gray/Matches Paint Color G2
- ◆ Grey Tigris/Grey Tigris L6
- ◆ White/Matches Paint
Color G1
- ◆ Whitestone/Matches Paint
Color K4

PAINTS CODES

P1

- ◆ Black P
- ◆ Brownstone P7D
- ◆ Charcoal S
- ◆ Fossil P28
- ◆ Greige T5
- ◆ Light Gray Q
- ◆ Loft LOFT
- ◆ Muslin T3
- ◆ Putty L
- ◆ Shadow * SHDW
- ◆ Titanium P8T

• STEEL DESKS

SPECIFY: Model Number.
Top Laminate
Paint Color

EXAMPLE: HP3276.NS

◆◆◆ For lead time information see page 19.

* De-emphasized



34000 SERIES

Steel Desks

GSA SIN 33721 EXCEPT AS NOTED

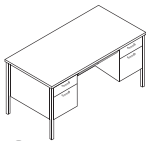
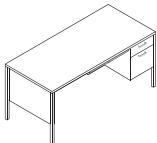
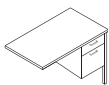

Icon Legend on page 19

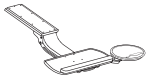
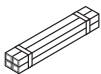
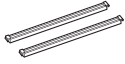
	DESCRIPTION	MODEL	SHIP WEIGHT	CUBE	LIST PRICE
	Double Pedestal — 2/2 (locking) 60"W x 30"D x 29½"H	H34962	162.0	26.7	\$1275
	Single Pedestal, box/file (locking) 66"W x 30"D x 29½"H, Right 66"W x 30"D x 29½"H, Left 48"W x 30"D x 29½"H, Right 45¼"W x 24"D x 29½"H, Right	H34973R H34974L H34251 H34002R	161.0 161.0 115.0 83.0	29.2 29.2 21.6 16.6	\$1101 \$1101 \$972 \$831
	Return, Box/File (non-locking) 42"W x 24"D x 29½"H, Right 42"W x 24"D x 29½"H, Left NOTES: Returns are for use with 66"W Single Pedestal Desks.	H34834R H34835L	89.0 89.0	15.5 15.5	\$732 \$732
	Credenza with Kneespace — 2/2 (non-locking) 60"W x 24"D x 29½"H ! Accommodates optional HD2 or HD8 center drawer.	H34480	160.0	21.8	\$1281
	Sit to Stand Arm with Convertible Keyboard Platform Articulating Arm with Convertible Keyboard Platform Articulating Arm with Keyboard Platform NOTES: For additional information see page 829.	H2516 * H2107 * H1706 *	17.0 \$ 16.0 \$ 16.0 \$	1.6 1.3 1.4	\$618 \$529 \$493
	Refer to page 829 for additional product information				
	OPEN MARKET				
	Chrome Leg Packs — Field Installable 4 pk-29½"H	HC14	7.2 \$	0.2	\$128
	Double-Rail Hanging File Racks — 2 Pack (for side-to-side) ! Gray only	H519495	0.5	0.5	\$33

NOTES:

- "Tru-fit" mitered drawer fronts for better visual alignment.
- 3/4 height modesty panels.
- Chrome legs shipped unattached.
- Laminate tops.
- Central locking center drawer standard, with HON "One Key" interchangeable lock cores.
- Full extension steel ball-bearing suspensions on file drawers for easy access to all contents.
- High-sided file drawers accept hanging files without hangrails.
- Box drawers equipped with 3/4 extension steel ball-bearing suspensions and one divider.
- Reinforced, double "O" frame inner structure keeps desk solid and sturdy for years of use.
- All interior drawer bodies are gray, pre-painted steel.
- ! Keyed alike cores ordered separately — see page 853.
- * De-emphasized.

HOW TO SPECIFY

Select Model Number	Select Laminate	Select Paint Color
See page 355	See page 355	See page 355
H 3 4 9 6 2	N	S



Icon Legend on page 19

34000 SERIES Accessories



Model HPWRMOD3WC shown

DESCRIPTION

Power Modules

- 3 Receptacles with Worksurface Clamp
- 2 Receptacles 2 USB with Worksurface Clamp
- 6' power cord with standard three-prong plug.
- Under-worksurface mounting bracket models work with any top that has a 5" x 5" square clearance.
- Worksurface clamp models work on any top with a 4" overhang.
- UL Listed.

NOTES: For additional information see page 849.

! Color finish coordinates with HON's Charcoal or White. Specify STRM for Storm or SNW for Snow when ordering. Example: HPWRMOD3WC.STRM.

MODEL

SHIP WEIGHT

CUBE

LIST PRICE

HPWRMOD3WC	2.3 Ⓢ	0.2	\$307
HPWRMOD2WC	2.3 Ⓢ	0.2	\$491

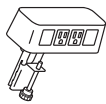

Power & Data Center

- 2 Receptacles 2 Data Accessory
- Standard with two receptacles and openings for two data ports.
- 6' power cord with standard three-prong plug.
- Fits on any worksurface with a 4" overhang.
- UL Listed.

NOTES: For additional information see page 849.

! Color finish coordinates with HON's Loft. Specify LOFT when ordering. Example: HCOMDOME2.LOFT.

HCOMDOME2

2.5 Ⓢ

0.2

\$293



Vertebrae

NOTES: 30"H x 3 1/8"W x 1 1/2"D. Ships unassembled. For additional information see page 852.

- ! Clear finish. Specify "X" for finish option.
- SPECIFYING EXAMPLE: HMPVWM28.X**

HMPVWM28

3.0

0.3

\$221

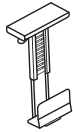

OPEN MARKET

CPU Holder

- Vertically mounts to underside of worksurface.
- 360° swivel.
- Supports up to 55 lbs.
- Height adjustable from 16" to 22" below worksurface.
- Width adjustable to accept units from 3 1/4" to 6".

NOTES: For additional information see page 827.

! Silver finish only, no specification needed.

HCPU *

16.0 Ⓢ

0.5

\$259

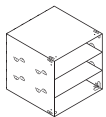

Storage Cube

12"W x 12"D
NOTES: For additional information see page 846.
SPECIFYING EXAMPLE: HLSL1212.P8S

HLSL1212

1.0

0.3

\$294



NOTES:

* De-emphasized.

HOW TO SPECIFY

Select Model Number

H P W R M O D 3 W C

NOTES

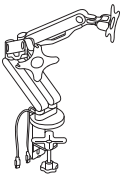
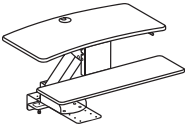
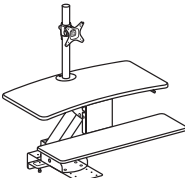
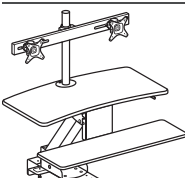
	DESCRIPTION	MODEL	SHIP WEIGHT	CUBE	LIST PRICE
	<p>Coordinate™ Portable Desktop Riser 31"D x 5'-16½"H x 35"W</p> <p>NOTES: Available in Black (BLK) or White (WHT) finish. Desktop riser dimensions (without keyboard tray): 22"D x 5'-16½"H x 35"W. Keyboard tray dimensions: 9"D x 30"W. Max loading capacity is 33 lbs for the desktop riser surface and 4 lbs for the keyboard tray. Easily transition from seated to standing positions throughout the workday. Sits atop an existing desk to create sit-to-stand functionality by raising the computer. Includes keyboard tray and surface for computer monitors. HON 5-Year Limited Warranty.</p> <p>⚠ Not intended for use on mobile workstations.</p>	HBXRISER	54.0	4.1	\$619
	<p>Dual Monitor Arm with 2 USB Ports</p> <p>NOTES: Easy adjustment. Height adjusts to 17" tall. Monitor tilt and swivel capability. Enclosed cable management. Grommet or desktop mounting. Clean appearance. In some applications the Monitor Arms may extend 12 or more inches into the worksurface. For additional information see page 825. HON 5-Year Limited Warranty.</p> <p>⚠ No specification needed.</p>	HBDMAUSB	41.9	2.6	\$441
	<p>Coordinate™ Mounted Desktop Riser</p> <p>NOTES: Does not include a monitor arm and is suitable for laptops and/or monitors on their original stands.</p> <p>⚠ No specification needed.</p>	HS1100	60.0 Ⓞ	3.2	\$664
	<p>Coordinate™ Mounted Desktop Riser with Single Monitor Arm</p> <p>NOTES: Includes a monitor arm for a single monitor.</p> <p>⚠ No specification needed.</p>	HS1101	62.0 Ⓞ	3.2	\$777
	<p>Coordinate™ Mounted Desktop Riser with Dual Monitor Arm</p> <p>NOTES: Includes a monitor arm for dual monitors.</p> <p>⚠ No specification needed.</p>	HS1102	63.0 Ⓞ	3.2	\$883

NOTES FOR HS1100, HS1101, HS1102:

- These products are designed to allow the user to transition from seating position to standing position throughout the workday.
- Gas-assist lever-operated mechanism with positive stop.
- Clamp mount compatible with worksurfaces depths of 20"-30". 20" is for systems only.
- Clamp requires 3.5" of clearance along back edge of worksurface.
- Black seamless worksurfaces.
- Silver powder coated metal components.
- Lowers below worksurface level on 24" and 30"D worksurfaces.
- All models contain a large primary worksurface and a smaller keyboard / mouse surface.
- Beveled edges for sleek appearance and comfort while typing.
- Monitor arms include height, width, and swivel adjustment.
- For additional information see page 838.

- Not for use under overhead storage, with flush mounted modesty panels, or worksurfaces thinner than 1".

⚠ Not recommended for use on mobile (castered) worksurfaces.

MOUNTING AND COMPATIBILITY FOR HS1100, HS1101, HS1102:

- This product is intended to be installed on commercial-grade worksurfaces in good condition.
- Compatible with freestanding worksurfaces 24"-30"D or panel-supported worksurfaces 24"-30"D.
- Not for use on mobile worksurfaces.

Clamp Mount

Use when 3.5" minimum overhang is available

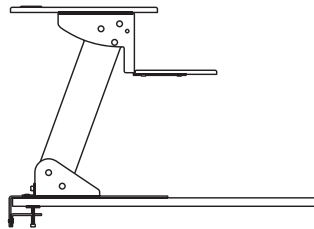

Screw Mount

Use when no overhang is available. Worksurface must be minimum 1" thick.

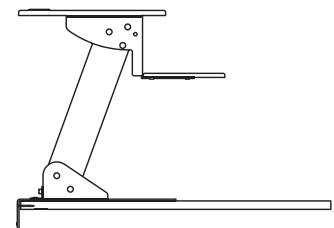

HOW TO SPECIFY

<p>Select Model Number</p> <p>HBXRISER.</p>	<p>Select Finish</p> <p>BLK Black WHT White</p> <p>BLK</p>
--	---



34000 SERIES

Accessories

OPEN MARKET

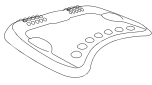
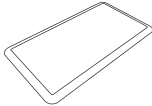
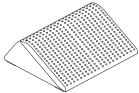

Icon Legend on page 19

	DESCRIPTION	MODEL	SHIP WEIGHT	CUBE	LIST PRICE
	Rectangle Wobble Board — Anti-Fatigue Mat 18"D x 3"H x 22 $\frac{1}{4}$ "W ⓘ Available in Black (T) finish ONLY. Recommended weight capacity not to exceed 250 pounds. HON 5-Year Limited Warranty. SPECIFYING EXAMPLE: HVL981.T	HVL981	10.0 ⓘ	0.9	\$120
	Round Wobble Board — Anti-Fatigue Mat 18 $\frac{1}{2}$ "D x 2 $\frac{1}{8}$ "H x 18 $\frac{1}{2}$ "W ⓘ Available in Black (T) finish ONLY. Recommended weight capacity not to exceed 250 pounds. HON 5-Year Limited Warranty. SPECIFYING EXAMPLE: HVL982.T	HVL982	5.8 ⓘ	0.6	\$102
	Ergonomic Anti-Fatigue Mat 25"D x 2 $\frac{3}{4}$ "H x 29 $\frac{7}{8}$ "W ⓘ Available in Black ONLY. No specification needed. SPECIFYING EXAMPLE: HBEAFM1	HBEAFM1	7.0	1.4	\$219
	Rectangle Anti-Fatigue Mat 20"D x $\frac{3}{4}$ "H x 36"W ⓘ Available in Black ONLY. No specification needed. SPECIFYING EXAMPLE: HBAFM2036	HBAFM2036	5.4	0.4	\$100
	Footrest — Anti-Slip Cover 13 $\frac{3}{4}$ "D x 5 $\frac{1}{2}$ "H x 16"W ⓘ Available in Black (T) finish ONLY. Recommended weight capacity not to exceed 250 pounds. HON 5-Year Limited Warranty. SPECIFYING EXAMPLE: HVL991.T	HVL991	7.0 ⓘ	0.9	\$82

HOW TO SPECIFY

Select
Model Number

H V L 9 8 1 .

Select
Finish

T Black

T

38000 SERIES™



38000 Series™ Station shown with Solve® Seating.

38000 SERIES™

The 38000 Series is America's best-selling steel desk — and with good reason. Rugged good looks. Precision engineering. Best-in-class construction. This modular collection blends designer touches like stylish, high-pressure laminate with useful details like cord-management. Which makes the 38000 Series the ideal desk solution for any organization seeking premium performance for a moderate price.



FEATURES

- Our steel construction is best in class — so it stands up to heavy use and frequent relocation.
- Integrated wire management and optional power hub accommodate today's electronic office.
- Pedestals feature Tru-Fit mitered drawer fronts for precision alignment when closed.
- Curved, waterfall-shaped edge profile provides a comfortable typing surface.
- Premium, multi-ply laminate worksurface stands up to scratches, spills and stains, and holds up under heavy use.
- Steel ball-bearing drawer suspensions operate easily and quietly.
- Cord management provides access to wall outlets, and allows cords to run through the or between components.

38000 SERIES™ ORDERING INFORMATION

FINISHES AVAILABILITY

L1 LAMINATES/EDGE BAND

COLOR CODES

Woodgrain

- ◆ Bourbon Cherry/
Bourbon Cherry **H**
- ◆ Cognac/Cognac **COGN**
- ◆ Florence Walnut/
Florence Walnut **LFW1**
- ◆ Harvest/Harvest **C**
- ◆ Kingswood Walnut/
Kingswood Walnut **LK11**
- ◆ Mahogany/Mahogany **N**
- ◆ Mocha/Mocha **MOCH**
- ◆ Natural Maple/
Natural Maple **D**
- ◆ Pinnacle/Pinnacle **PINC**
- ◆ Shaker Cherry/
Shaker Cherry **F**
- ◆ Sterling Ash/
Sterling Ash **LSA1**

Solid

- ◆ Black/Black **P**
- ◆ Charcoal/Charcoal **S**
- ◆ Designer White/
Designer White **LDW1**
- ◆ Loft/Loft **LOFT**

Patterned

- ◆ Sheer Mesh/Muslin **A5**
- ◆ Silver Mesh/Loft **B9**
- ◆ Steel Mesh/Charcoal **A9**
- ◆ Canyon Zephyr/
Greige **K9**
- ◆ Desert Zephyr/
Greige **K8**
- ◆ Shadow Zephyr/
Loft **K1**
- ◆ Gray/Matches Paint Color **G2**
- ◆ Grey Tigris/Greige **L6**
- ◆ White/Matches Paint Color .. **G1**
- ◆ Whitestone/Matches Paint
Color **K4**

FINISHES AVAILABILITY *continued*

PAINTS CODES

P1

- ◆ Black **P**
- ◆ Brownstone **P7D**
- ◆ Charcoal **S**
- ◆ Designer White **PJW**
- ◆ Fossil **P28**
- ◆ Greige **T5**
- ◆ Light Gray **Q**
- ◆ Loft **LOFT**
- ◆ Muslin **T3**
- ◆ Putty **L**
- ◆ Shadow * **SHDW**
- ◆ Titanium **P8T**

P2

- ◆ Champagne Metallic **T4**
- ◆ Platinum Metallic **T1**

NOTE: Where 38000 edgeband does not match laminate color, alternative color is on flat edges only (sides, sides and back edge on returns and bridges, flat sides of corner unit, and flat end of peninsulas).

• STEEL DESKS

SPECIFY: Model Number.
Top Laminate
Paint Color

EXAMPLE: H38934.NS

• 38000

(Fabric listed on pages 25-26)

SPECIFY: Model Number
Fabric Style.
Color Code
Paint Color

EXAMPLE: HT72.CE18.P

◆◆◆ For lead time information see page 19.

* De-emphasized



Icon Legend on page 19

38000 SERIES™ Typicals — 3/4 Height Pedestals

Components used are listed on pages 367-376. Order components individually. Other configurations are possible, including various sizes of some components.

QTY	DESCRIPTION	MODEL	LIST PRICE	PRICE EXTENSION
1	Double Pedestal Desk 72"W x 36"D x 29½"H	H38180	\$1,930	\$1,930
1	Credenza with Kneespace 72"W x 24"D x 29½"H	H38854	\$1,676	\$1,676
TOTAL:			\$3,606	

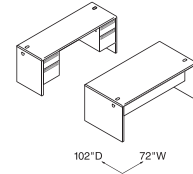

DESK WORKSTATION WITH CREDEZA
72"W x 102"D

QTY	DESCRIPTION	MODEL	LIST PRICE	PRICE EXTENSION
1	Single Pedestal Desk 72"W x 36"D x 29½"H	H38293R	\$1,721	\$1,721
1	Stack-on Storage w/o Doors 72½"W x 13½"D x 34¾"H	H386572N	\$908	\$908
1	Bridge 48"W x 24"D x 37⅞"H	H38210	\$579	\$579
1	Flipper Doors 2@36"W x 15"H	H387215	\$564	\$564
1	Single Pedestal Credenza 72"W x 24"D x 29½"H	H38855L	\$1,428	\$1,428
TOTAL:			\$5,200	

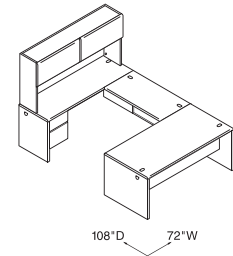

DESK "U" WORKSTATION
72"W x 108"D

QTY	DESCRIPTION	MODEL	LIST PRICE	PRICE EXTENSION
1	Single Pedestal Desk 72"W x 36"D x 29½"H	H38293R	\$1,721	\$1,721
1	Stack-on Storage w/o Doors 72½"W x 13½"D x 34¾"H	H386572N	\$908	\$908
1	Left, Return, box/file 60"W x 24"D x 29½"H	H38218L	\$1,143	\$1,143
1	Flipper Doors 2@36"W x 15"H	H387215	\$564	\$564
TOTAL:			\$4,336	

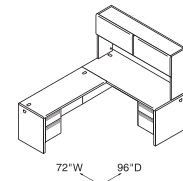

DESK "L" WORKSTATION
72"W x 96"D

QTY	DESCRIPTION	MODEL	LIST PRICE	PRICE EXTENSION
1	Peninsula with Full End Panel 70"W x 36"D x 29½"H	H38941	\$1,344	\$1,344
1	Stack-on Storage w/o Doors 72½"W x 13½"D x 34¾"H	H386572N	\$908	\$908
1	Bridge 42"W x 24"D x 29½"H	H38220	\$551	\$551
1	Flipper Doors 2@36"W x 15"H	H387215	\$564	\$564
1	Single Pedestal Credenza, Left 72"W x 24"D x 29½"H	H38855L	\$1,428	\$1,428
TOTAL:			\$4,795	

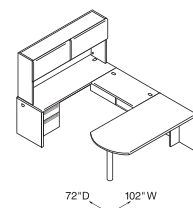

PENINSULA "U" WORKSTATION
72"W x 102"D

38000 SERIES™

Typicals — Modular



Icon Legend on page 19

Components used are listed on pages 367-376. Order components individually. Other configurations are possible, including various sizes of some components.

QTY	DESCRIPTION	MODEL	LIST PRICE	PRICE EXTENSION
1	Shell Desk 72"W x 36"D x 29½"H	H38934	\$1,170	\$1,170
1	Flagship Mobile Pedestal – file/file 15"W x 22⅞"D x 28"H	H18823R	\$723	\$723
1	Return Shell, Left 48"W x 24"D x 29½"H	H38944L	\$815	\$815
1	Standard Height Mobile Pedestal – box/box/file 15"W x 16⅞"D x 28"H	H18717R	\$679	\$679
TOTAL:			\$3,387	

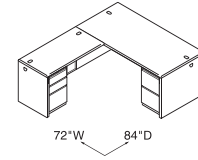

MODULAR DESK WORKSTATION
84"W x 72"D

QTY	DESCRIPTION	MODEL	LIST PRICE	PRICE EXTENSION
1	Shell Desk 72"W x 36"D x 29½"H	H38934	\$1,170	\$1,170
1	Flagship Mobile Pedestal – file/file 15"W x 22⅞"D x 28"H	H18823R	\$723	\$723
1	Bridge 48"W x 24"D x 29½"H	H38210	\$579	\$579
1	Shell Desk 72"W x 24"D x 29½"H	H38925	\$1,132	\$1,132
1	Standard Height Mobile Pedestal – box/box/file 15"W x 16⅞"D x 28"H	H18717R	\$679	\$679
1	Stack-on Storage w/o Doors 72⅝"W x 13½"D x 34¾"H	H386572N	\$908	\$908
TOTAL:			\$5,191	

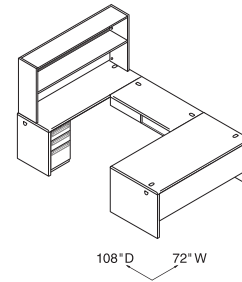

MODULAR DESK "U" WORKSTATION
72"W x 108"D

QTY	DESCRIPTION	MODEL	LIST PRICE	PRICE EXTENSION
1	Corner Unit	H38928	\$1,315	\$1,315
1	Peninsula with End Panel 70"W x 36"D x 29½"H	H38941	\$1,344	\$1,344
1	Bridge 42"W x 24"D x 29½"H	H38220	\$551	\$551
1	Shell Return, Right 72"W x 24"D x 29½"H	H38947R	\$1,086	\$1,086
1	Flagship Lateral File 30"W x 18"D x 28"H	H9170R	\$960	\$960
1	Stack-on Storage w/o Doors 72⅝"W x 13½"D x 34¾"H	H386572N	\$908	\$908
1	Flipper Doors 2@36"W x 15"H	H387215	\$564	\$564
TOTAL:			\$6,728	

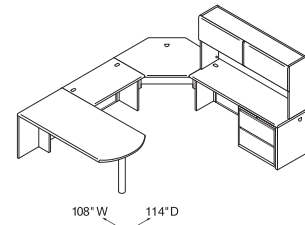

PENINSULA "U" WORKSTATION
108"W x 114"D

QTY	DESCRIPTION	MODEL	LIST PRICE	PRICE EXTENSION
1	Corner Unit	H38928	\$1,315	\$1,315
1	Shell Return, Left 72"W x 24"D x 29½"H	H38948L	\$1,086	\$1,086
1	Standard Height Mobile Pedestal – box/box/file 15"W x 16⅞"D x 28"H	H18717R	\$679	\$679
1	Stack-on Storage w/o Doors 72⅝"W x 13½"D x 34¾"H	H386572N	\$908	\$908
1	Flipper Doors 2@36"W x 15"H	H387215	\$564	\$564
1	Shell Return – Right 72"W x 24"D x 29½"H	H38947R	\$1,086	\$1,086
1	Standard Height Mobile Pedestal – file/file 15"W x 16⅞"D x 28"H	H18817R	\$673	\$673
TOTAL:			\$6,311	

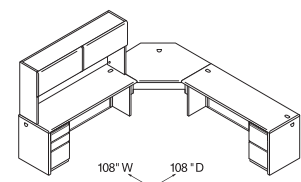

CORNER UNIT WITH RETURNS WORKSTATION
108"W x 108"D



Icon Legend on page 19

38000 SERIES™ Bundles Typicals

Mahogany/Charcoal
H38LL7284NS

Harvest/Putty
H38LL7284CL

QTY	DESCRIPTION	MODEL	LIST PRICE	PRICE EXTENSION
1	Left Pedestal Desk	H38294L	\$1,721	\$1,721
1	Right Return	H38215R	\$1,041	\$1,041
TOTAL:			\$2,762	

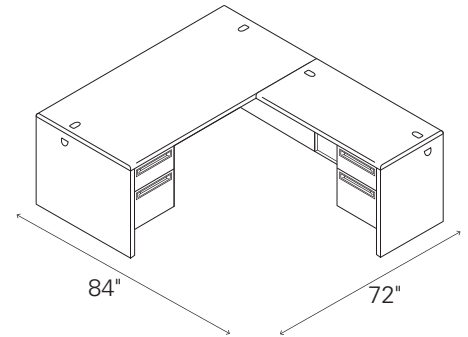

L-STATION (LEFT DESK/RIGHT RETURN)

Mahogany/Charcoal
H38LR7284NS

Harvest/Putty
H38LR7284CL

QTY	DESCRIPTION	MODEL	LIST PRICE	PRICE EXTENSION
1	Right Pedestal Desk	H38293R	\$1,721	\$1,721
1	Left Return	H38216L	\$1,041	\$1,041
TOTAL:			\$2,762	

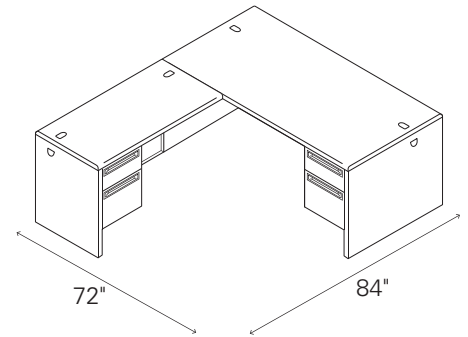

L-STATION (RIGHT DESK/LEFT RETURN)

Mahogany/Charcoal
H38URH72108NS2

Harvest/Putty
H38URH72108CL2

QTY	DESCRIPTION	MODEL	LIST PRICE	PRICE EXTENSION
1	Single Pedestal Desk, Right	H38293R	\$1,721	\$1,721
1	Single Pedestal Credenza, Left	H38855L	\$1,428	\$1,428
1	Hutch without Doors	H386572N	\$908	\$908
1	Flipper Doors, Pair	H387215	\$564	\$564
1	Bridge	H38210	\$579	\$579
TOTAL:			\$5,200	

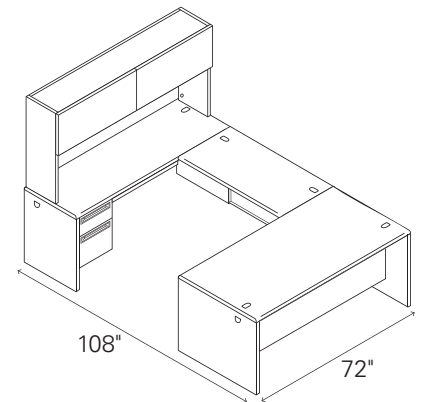

**U-STATION WITH HUTCH
(RIGHT DESK/LEFT CREDENZA)**

38000 SERIES™

Bundles Typicals



Icon Legend on page 19

Mahogany/Charcoal
H38ULH72108NS2

Harvest/Putty
H38ULH72108CL2

QTY	DESCRIPTION	MODEL	LIST PRICE	PRICE EXTENSION
1	Single Pedestal Desk, Left	H38294L	\$1,721	\$1,721
1	Single Pedestal Credenza, Right	H38856R	\$1,428	\$1,428
1	Hutch without Doors	H386572N	\$908	\$908
1	Flipper Doors, Pair	H387215	\$564	\$564
1	Bridge	H38210	\$579	\$579
TOTAL:				\$5,200

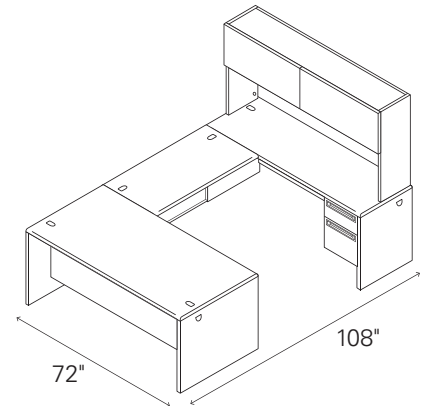

**U-STATION WITH HUTCH
(LEFT DESK/RIGHT CREDENZA)**

Mahogany/Charcoal
H38DCH6096NS2

Harvest/Putty
H38DCH6096CL2

QTY	DESCRIPTION	MODEL	LIST PRICE	PRICE EXTENSION
1	Double Pedestal Desk	H38155	\$1,650	\$1,650
1	Double Pedestal Credenza	H38852	\$1,611	\$1,611
1	Hutch without Doors	H386560N	\$798	\$798
1	Flipper Doors, Pair	H386015	\$531	\$531
TOTAL:				\$4,590

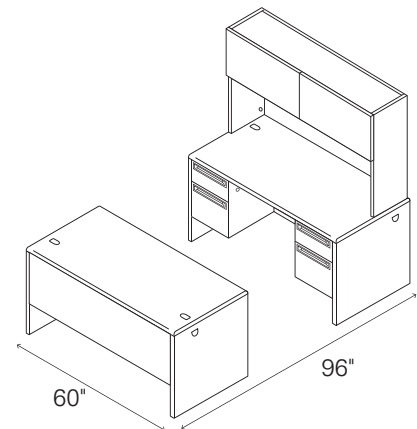

WORKSTATION



38000 SERIES™

Steel Desks — 3/4 Pedestals

	DESCRIPTION	FULL WIDTH OVERHANG	MODEL	SHIP WEIGHT	CUBE	LIST PRICE BY PAINT GRADE		
						P1	P2	P3
	Double Pedestal — 2/2 w/Locks	6"						
	72"W x 36"D x 29½"H		H38180	256	51.7	\$1930	\$2004	\$2075
	66"W x 30"D x 29½"H		H38170	224	40.1	\$1848	\$1922	\$1993
	60"W x 30"D x 29½"H		H38155	217	36.6	\$1650	\$1724	\$1795
	Single Pedestal w/Lock	6"						
	72"W x 36"D x 29½"H — 2R		H38293R	214	51.7	\$1721	\$1795	\$1866
	66"W x 30"D x 29½"H — 2R		H38291R	181	40.1	\$1585	\$1659	\$1730
	48"W x 30"D x 29½"H — 2R	H38251	155	29.6	\$1403	\$1477	\$1548	
	72"W x 36"D x 29½"H — 2L	6"	H38294L	214	51.7	\$1721	\$1795	\$1866
	66"W x 30"D x 29½"H — 2L	H38292L	181	40.1	\$1585	\$1659	\$1730	
	48"W x 30"D x 29½"H — 2L		H38252L	155	29.6	\$1403	\$1477	\$1548
	Flush Return — box/file w/Lock							
	60"W x 24"D x 29½"H — 2R		H38217R	138	30.1	\$1143	\$1188	\$1232
	48"W x 24"D x 29½"H — 2R		H38215R	124	24.1	\$1041	\$1086	\$1130
	60"W x 24"D x 29½"H — 2L		H38218L	138	30.1	\$1143	\$1188	\$1232
	48"W x 24"D x 29½"H — 2L		H38216L	124	24.1	\$1041	\$1086	\$1130
	NOTES: Returns have 2 grommets each in worksurface top and full height modesty panel.							
	Credenza w/Doors w/Locks							
72"W x 24"D x 29½"H		H38853	230	35.6	\$1821	\$1895	\$1966	
	NOTES: Pedestals lock.							
	Credenza w/Kneespace w/Locks							
	72"W x 24"D x 29½"H		H38854	172	35.6	\$1676	\$1750	\$1821
	Kneespace: 39¾"W		H38851	166	32.7	\$1640	\$1714	\$1785
	66"W x 24"D x 29½"H		H38852	154	29.8	\$1611	\$1685	\$1756
	Kneespace: 33¾"W							
	60"W x 24"D x 29½"H							
	Kneespace: 27¾"W							
	NOTES: Pedestals lock.							
	Single Pedestal Credenza — 2R w/Lock							
	72"W x 24"D x 29½"H		H38856R	159	35.6	\$1428	\$1502	\$1573
	66"W x 24"D x 29½"H		H38858R	153	32.7	\$1324	\$1398	\$1469
	NOTES: Pedestal locks.							
	Single Pedestal Credenza — 2L w/Lock							
	72"W x 24"D x 29½"H		H38855L	159	35.6	\$1428	\$1502	\$1573
	66"W x 24"D x 29½"H		H38857L	153	32.7	\$1324	\$1398	\$1469
	NOTES: Pedestal locks.							

NOTES:

- 3/4 height modesty panels unless noted.
- Color of pulls and grommets match paint selection for core colors.
- One pencil tray standard per unit except returns.
- Laminate particleboard tops feature attractive, radius edges on front and rear edges of desks. Returns and bridges have radius front and flat rear edge to match the side edge it attaches to.
- Wire grommets standard in all tops.
- Wire grommets in end panels allow cable connections between desks.
- "Tru-fit" mitered drawer fronts for better visual alignment.
- Optional center drawer features steel ball-bearing suspension.
- High-sided file drawers accept hanging files without hangrails.
- Three-part full extension steel ball-bearing suspension on all file drawers for full access to interior contents.
- Box drawers feature two-part, ¾" extension steel ball-bearing suspension.
- Baked enamel finish over rust-inhibiting phosphate pre-treatment.
- See page 369 for 38000 Series™ shared components.

HOW TO SPECIFY

Select Model Number 	Select Laminate See page 362 	Select Paint Color See page 362
--------------------------------	--	---

38000 SERIES™ Modular Desks

GSA SIN 33721



Icon Legend on page 19

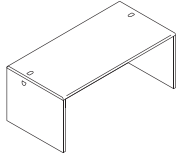

DESCRIPTION	INSIDE SHELL DIMENSIONS	FULL WIDTH OVERHANG	MODEL	SHIP WEIGHT	CUBE	LIST PRICE BY PAINT GRADE		
						P1	P2	P3
Desk Shell								
72"W x 36"D x 29½"H	69½"W x 28¾"D	6"	H38934	134	7.1	\$1170	\$1244	\$1315
72"W x 30"D x 29½"H	69½"W x 28¾"D		H38935	118	6.0	\$1139	\$1213	\$1284
66"W x 30"D x 29½"H	63½"W x 28¾"D		H38933	108	6.0	\$1122	\$1196	\$1267
60"W x 30"D x 29½"H	57½"W x 28¾"D		H38932	103	5.1	\$1067	\$1141	\$1212
48"W x 30"D x 29½"H	45½"W x 28¾"D		H38931	89	5.1	\$986	\$1060	\$1131
72"W x 24"D x 29½"H	69½"W x 22¾"D		H38925	99	5.0	\$1132	\$1206	\$1277
66"W x 24"D x 29½"H	63½"W x 22¾"D		H38923	95	5.0	\$1084	\$1158	\$1229
60"W x 24"D x 29½"H	57½"W x 22¾"D		H38922	89	4.2	\$1031	\$1105	\$1176
48"W x 24"D x 29½"H	45½"W x 22¾"D		H38921	83	4.2	\$965	\$1039	\$1110

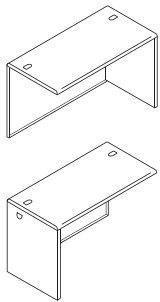

Return Shell								
72"W x 24"D x 29½"H, Right	69½"W x 22¾"D (2 grommets)		H38947R	87	6.0	\$1086	\$1131	\$1175
60"W x 24"D x 29½"H, Right	57½"W x 22¾"D (2 grommets)		H38945R	80	5.1	\$974	\$1019	\$1063
48"W x 24"D x 29½"H, Right	45½"W x 22¾"D (2 grommets)		H38943R	71	4.2	\$815	\$860	\$904
42"W x 24"D x 29½"H, Right	39½"W x 22¾"D (2 grommets)		H38949R	65	4.2	\$759	\$804	\$848
72"W x 24"D x 29½"H, Left	69½"W x 22¾"D (2 grommets)		H38948L	87	6.0	\$1086	\$1131	\$1175
60"W x 24"D x 29½"H, Left	57½"W x 22¾"D (2 grommets)		H38946L	80	5.1	\$974	\$1019	\$1063
48"W x 24"D x 29½"H, Left	45½"W x 22¾"D (2 grommets)		H38944L	71	4.2	\$815	\$860	\$904
42"W x 24"D x 29½"H, Left	39½"W x 22¾"D (2 grommets)		H38950L	65	4.2	\$759	\$804	\$848

NOTES: Modular returns feature full height modesty panels.

⚠ Not designed to be used freestanding.

NOTES:

- 38000 Series™ Modular Desks offers designer styling, configuration flexibility and storage versatility.
- Create both individual managerial stations and task-oriented work areas.
- Designed with adaptability for today's electronic office.
- Color of pulls and grommets match paint selection for core colors.
- Wire grommets standard in all tops, except peninsulas.
- Wire grommets in end panels allow cable connections between desks.
- Optional center drawer features steel ball-bearing suspension.
- For components that can be shared with 38000 Series™, see page 369.
- 3/4 height modesty panels unless noted.
- Ability to use all HON laterals and pedestals.

Recommended Pedestal Options:

38000 Series™	36" Deep Desk			30" Deep Desk			24" Deep Desk		
	Ability to Attach	Ability to Use Wire Port	Ability to Attach Hutch	Ability to Attach	Ability to Use Wire Port	Ability to Attach Hutch	Ability to Attach	Ability to Use Wire Port	Ability to Attach Hutch
16¾"D Hanging Pedestal	•	•	•	•	•	•	•		•
22⅞"D Hanging Pedestal	•	•	•	•	•	•	•		•
16¾"D Freestanding or Mobile	•	•	•	•	•	•	•		•
22⅞"D Freestanding or Mobile	•	•	•	•	•	•	•		•
28⅞"D Freestanding or Mobile	•		•	•		•			

Use of a pedestal spacer or 28"H standard height pedestals will block wire access from the grommet to the kneespace area.

NOTES: Stack-on units can be attached regardless of pedestal configuration.

Personalize Your Storage Needs**With These Possible Solutions:**

Use coordinating HON components such as Pedestals shown on page 652 and Lateral Files shown on pages 616-620 and 654-655.

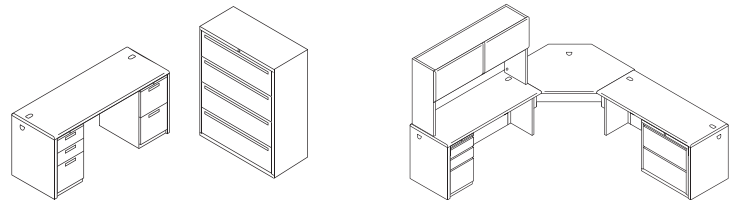
**HOW TO SPECIFY**

Select Model Number

H 3 8 9 3 4 .

Select Laminate

See page 362

N .

Select Paint Color

See page 362

S .



Icon Legend on page 19

	DESCRIPTION	MODEL	SHIP WEIGHT	CUBE	LIST PRICE BY PAINT GRADE		
					P1	P2	P3
	Peninsula with Support Column and End Panel 70"W x 36"D x 29½"H 70"W x 30"D x 29½"H 66"W x 30"D x 29½"H	H38941 H38942 H38966	136.0 130.0 117.0	15.5 13.2 13.2	\$1344 \$1277 \$1241	\$1389 \$1322 \$1286	\$1433 \$1366 \$1330
	NOTES: Use to create "L" configuration with a Return or "U" configuration with a Bridge and Credenza, Desk or Corner Unit. ⓘ Not designed to be used freestanding.						
	Corner Unit 24" x 36" x 36" x 24" x 29½"H Leading edge is 17"W; leading edge to rear edge is 36"D. ⓘ Designed to be used with Returns or Bridges.		H38928	85.0	7.4	\$1315	\$1389
	Bridge 48"W x 24"D x 29½"H 42"W x 24"D x 29½"H	H38210 H38220	54.0 ⓘ 50.0 ⓘ	4.2 4.2	\$579 \$551	\$597 \$569	\$612 \$584
	NOTES: Full height modesty panel.						
<p>Refer to page 833</p>	Metal Center Drawers with core removable locks 24¾"W x 14¾"D for H38180, H38170, H38155 19"W x 14¾"D for H38293R, H38294L, H38291R, H38292L	HD8 HD2	12.0 ⓘ 9.0 ⓘ	1.2 1.0	\$257 \$257	\$267 \$267	\$275 \$275
	NOTES: For additional information see page 833. Specify: Paint color.						
<p>OPEN MARKET</p>	Polymer Center Drawer <ul style="list-style-type: none"> • Color: Black. • Material: ABS. • Opening Requirements: 23"W x 16¼"D x 2"H. • Retracts on 16" ball-bearing slides. • Can be used on worksurfaces with Coordinate™ Height Adjustable Bases as long as it is attached with spacer model HKBS. • Can store up to 25 lbs. 	HCD1	7.0	0.5	\$108		
	NOTES: For additional information see page 833. ⓘ Black finish only, no specification needed.						
<p>Refer to page 831</p>	Corner Sleeve — Square Edge 22½" leading edge x 18"D	H51206	10.0 ⓘ	1.5	\$155	\$165	\$172
	NOTES: For additional information see page 831. Specify: Paint color.						
<p>Refer to page 830 for additional product information</p>	Slide-Away Keyboard Platform (Specify: Laminate) Metal Keyboard and Mouse Tray (Specify paint) Metal Keyboard Tray (Specify paint)	H4022 H4028 OPEN MARKET H4029 OPEN MARKET	10.0 ⓘ 11.0 ⓘ 11.0 ⓘ	0.6 1.5 1.5	\$213 \$153 \$138	\$163 \$148	
	NOTES: For additional information see page 830.						
	Double-Rail Hanging File Racks — 2 Pack (for side-to-side)	H519495	0.5	0.5	\$33		

NOTES:

- Full end panel legs have neat, contemporary appearance.
- ¾ height modesty panels unless noted.
- Our broadest selection of components, including components for "U" and "L" workstation arrangements.

- All worksurfaces shown are particleboard.
- Color of grommets match paint selection for core colors.
- 38000 Series™ Stack-on units and accessories listed on pages 369-376.

HOW TO SPECIFY

Select Model Number H 3 8 9 4 1	Select Laminate See page 362 N	Select Paint Color See page 362 S
---	---	--

38000 SERIES™

Accessories

GSA SIN 33721 EXCEPT AS NOTED

ABI

Icon Legend on page 19

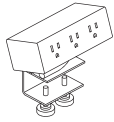

Model HPWRMOD3WC shown

DESCRIPTION**Power Modules**

3 Receptacles with Worksurface Clamp

2 Receptacles 2 USB with Worksurface Clamp

- 6' power cord with standard three-prong plug.

- Under-worksurface mounting bracket models work with any top that has a 5" x 5" square clearance.

- Worksurface clamp models work on any top with a 4" overhang.

- UL Listed.

NOTES: For additional information see page 849.

! Color finish coordinates with HON's Charcoal or White. Specify *STRM* for Storm or *SNW* for Snow when ordering.
Example: HPWRMOD3WC.STRM.

MODEL**SHIP WEIGHT****CUBE****LIST PRICE****HPWRMOD3WC**

2.3 Ⓢ

0.2

\$307**HPWRMOD2WC**

2.3 Ⓢ

0.2

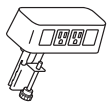
\$491**Power & Data Center**

2 Receptacles 2 Data Accessory

- Standard with two receptacles and openings for two data ports.

- 6' power cord with standard three-prong plug.

- Fits on any worksurface with a 4" overhang.

- UL Listed.

NOTES: For additional information see page 849.

! Color finish coordinates with HON's Loft. Specify *LOFT* when ordering. Example: HCOMDOME2.LOFT.

HCOMDOME2

2.5 Ⓢ

0.2

\$293**Vertebrae**

NOTES: 30"H x 3 1/8"W x 1 1/2"D. Ships unassembled. For additional information see page 852.

! Clear finish. Specify "X" for finish option.

SPECIFYING EXAMPLE: HMPVWM28.X**HMPVWM28**

3.0

0.3

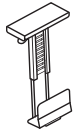
\$221

OPEN MARKET

CPU Holder

- Vertically mounts to underside of worksurface.

- 360° swivel.

- Supports up to 55 lbs.

- Height adjustable from 16" to 22" below worksurface.

- Width adjustable to accept units from 3 1/4" to 6".

NOTES: For additional information see page 827.

! Silver finish only, no specification needed.

HCPU Ⓢ

16.0 Ⓢ

0.5

\$259**Storage Cube**

12"W x 12"D

NOTES: For additional information see page 846.

SPECIFYING EXAMPLE: HLSL1212.P8S**HLSL1212**

1.0

0.3

\$294**NOTES:**

* De-emphasized.

HOW TO SPECIFY

Select
Model Number

H P W R M O D 3 W C

38000 SERIES™

Accessories

OPEN MARKET

Icon Legend on page 19

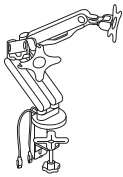
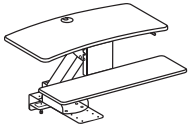
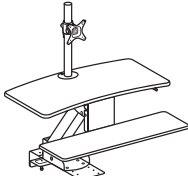
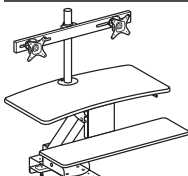
	DESCRIPTION	MODEL	SHIP WEIGHT	CUBE	LIST PRICE
	Coordinate™ Portable Desktop Riser 31"D x 5'-16½"H x 35"W NOTES: Available in Black (BLK) or White (WHT) finish. Desktop riser dimensions (without keyboard tray): 22"D x 5'-16½"H x 35"W. Keyboard tray dimensions: 9"D x 30"W. Max loading capacity is 33 lbs for the desktop riser surface and 4 lbs for the keyboard tray. Easily transition from seated to standing positions throughout the workday. Sits atop an existing desk to create sit-to-stand functionality by raising the computer. Includes keyboard tray and surface for computer monitors. HON 5-Year Limited Warranty. ⓘ Not intended for use on mobile workstations.	HBXRISER	54.0	4.1	\$619
	Dual Monitor Arm with 2 USB Ports NOTES: Easy adjustment. Height adjusts to 17" tall. Monitor tilt and swivel capability. Enclosed cable management. Grommet or desktop mounting. Clean appearance. In some applications the Monitor Arms may extend 12 or more inches into the worksurface. For additional information see page 825. HON 5-Year Limited Warranty. ⓘ No specification needed.	HBDMAUSB	41.9	2.6	\$441
	Coordinate™ Mounted Desktop Riser NOTES: Does not include a monitor arm and is suitable for laptops and/or monitors on their original stands. ⓘ No specification needed.	HS1100	60.0 ⓘ	3.2	\$664
	Coordinate™ Mounted Desktop Riser with Single Monitor Arm NOTES: Includes a monitor arm for a single monitor. ⓘ No specification needed.	HS1101	62.0 ⓘ	3.2	\$777
	Coordinate™ Mounted Desktop Riser with Dual Monitor Arm NOTES: Includes a monitor arm for dual monitors. ⓘ No specification needed.	HS1102	63.0 ⓘ	3.2	\$883

NOTES FOR HS1100, HS1101, HS1102:

- These products are designed to allow the user to transition from seating position to standing position throughout the workday.
- Gas-assist lever-operated mechanism with positive stop.
- Clamp mount compatible with worksurfaces depths of 20"-30". 20" is for systems only.
- Clamp requires 3.5" of clearance along back edge of worksurface.
- Black seamless worksurfaces.
- Silver powder coated metal components.
- Lowers below worksurface level on 24" and 30"D worksurfaces.
- All models contain a large primary worksurface and a smaller keyboard / mouse surface.
- Beveled edges for sleek appearance and comfort while typing.
- Monitor arms include height, width, and swivel adjustment.
- For additional information see page 838.

- Not for use under overhead storage, with flush mounted modesty panels, or worksurfaces thinner than 1".

- ⓘ Not recommended for use on mobile (castered) worksurfaces.

MOUNTING AND COMPATIBILITY FOR HS1100, HS1101, HS1102:

- This product is intended to be installed on commercial-grade worksurfaces in good condition.
- Compatible with freestanding worksurfaces 24"-30"D or panel-supported worksurfaces 24"-30"D.
- Not for use on mobile worksurfaces.

Clamp Mount

Use when 3.5" minimum overhang is available

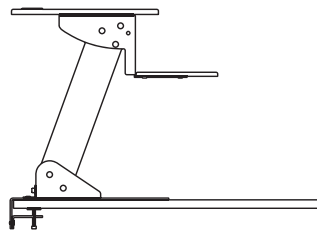

Screw Mount

Use when no overhang is available. Worksurface must be minimum 1" thick.

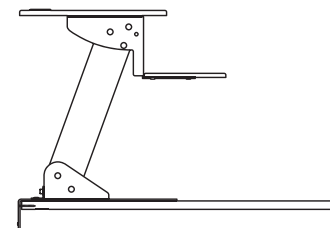



HOW TO SPECIFY

Select Model Number

Select Finish

BLK Black
WHT White

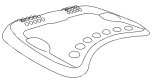
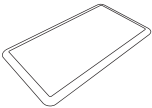
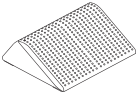

	DESCRIPTION	MODEL	SHIP WEIGHT	CUBE	LIST PRICE
	Rectangle Wobble Board — Anti-Fatigue Mat 18"D x 3"H x 22½"W ⓘ Available in Black (T) finish ONLY. Recommended weight capacity not to exceed 250 pounds. HON 5-Year Limited Warranty. SPECIFYING EXAMPLE: HVL981.T	HVL981	10.0 Ⓢ	0.9	\$120
	Round Wobble Board — Anti-Fatigue Mat 18½"D x 2⅝"H x 18½"W ⓘ Available in Black (T) finish ONLY. Recommended weight capacity not to exceed 250 pounds. HON 5-Year Limited Warranty. SPECIFYING EXAMPLE: HVL982.T	HVL982	5.8 Ⓢ	0.6	\$102
	Ergonomic Anti-Fatigue Mat 25"D x 2¾"H x 29⅞"W ⓘ Available in Black ONLY. No specification needed. SPECIFYING EXAMPLE: HBEAFM1	HBEAFM1	7.0	1.4	\$219
	Rectangle Anti-Fatigue Mat 20"D x ¾"H x 36"W ⓘ Available in Black ONLY. No specification needed. SPECIFYING EXAMPLE: HBAFM2036	HBAFM2036	5.4	0.4	\$100
	Footrest — Anti-Slip Cover 13¾"D x 5½"H x 16"W ⓘ Available in Black (T) finish ONLY. Recommended weight capacity not to exceed 250 pounds. HON 5-Year Limited Warranty. SPECIFYING EXAMPLE: HVL991.T	HVL991	7.0 Ⓢ	0.9	\$82

HOW TO SPECIFY

Select Model Number	Select Finish
H V L 9 8 1 .	T Black
	T

38000 SERIES™

Steel Stack-on Units

GSA SIN 33721

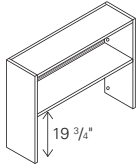

Icon Legend on page 19

**DESCRIPTION****Stack-on Full Clearance without Doors**

72"W x 13½"D x 34¾"H

66"W x 13½"D x 34¾"H

60"W x 13½"D x 34¾"H

48"W x 13½"D x 34¾"H

NOTES: Interior is 12¾"H.

Specify: Paint color.

MODEL**SHIP WEIGHT****CUBE****LIST PRICE BY PAINT GRADE****P1****P2****P3****H386572N**

72

6.8

\$908**\$959****\$1008****H386566N**

68

6.3

\$861**\$912****\$961****H386560N**

64

5.7

\$798**\$849****\$898****H386548N**

53

4.7

\$728**\$779****\$828****HOW TO SPECIFY****Select Model Number**

H 3 8 6 5 7 2 N .

Select Paint Color

See page 362

P

DESCRIPTION**Front Flipper Doors**

2 @ 36"W x 15"H, Flipper Doors for 72"W Stack-on

2 @ 33"W x 15"H, Flipper Doors for 66"W Stack-on

2 @ 30"W x 15"H, Flipper Doors for 60"W Stack-on

1 @ 48"W x 15"H, Flipper Door for 48"W Stack-on

Specify: Paint color.

MODEL**SHIP WEIGHT****CUBE****LIST PRICE BY PAINT GRADE****P1****P2****P3****H387215**

19

0.9

\$564**\$582****\$608****H386615**

17

0.9

\$552**\$570****\$596****H386015**

16

0.9

\$531**\$549****\$575****H384815**

12

0.5

\$322**\$340****\$366****NOTES:**

- Flipper doors are standard with a core removable lock located on the underside of stack-on shelf.
- Many Stack-on sizes available, from 48" to 72" wide.
- Equipped with HON "One Key" interchangeable core removable locks.
- Stack-on units attach to worksurface with double stick tape or with screws provided.
- Stack-ons also compatible with Abode™, Mentor®, Metro Classic, and 66000 Series Computer Furniture.
- Cabinet/door combination kits available for field installation.
- Two dividers standard with every stack-on.
- Color of grommets match paint selection for core colors.

ⓘ Keyed alike cores must be ordered separately — see page 853.

ⓘ Stack-on Units not designed to be used on Corner Units.

HOW TO SPECIFY**Select Model Number**

H 3 8 7 2 1 5 .

Select Lock Option

L Lock
 X Omit Lock
 (deduct \$20)

See page 853 for omit lock ordering instructions

L .

Select Paint Color

See page 362

P



Icon Legend on page 19

38000 SERIES™ Steel Stack-on Units



DESCRIPTION	MODEL	SHIP WEIGHT	CUBE	LIST PRICE BY PAINT GRADE		
				P1	P2	P3
Shelf Dividers — package of 6 <small>Specify: Paint color. Shelf dividers can only be used on stack-ons manufactured after 7/3/2000.</small>	H38SHFDV	3	0.2	\$145	\$156	\$164

HOW TO SPECIFY

<p>Select Model Number</p> <p>H 3 8 S H F D V .</p>	<p>Select Paint Color</p> <p>See page 362</p> <p>P</p>
---	--

38000 SERIES™

Steel Stack-on Units

GSA SIN AS NOTED



Icon Legend on page 19

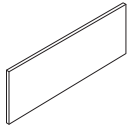

SIN 33721

DESCRIPTION**for Stack-on — 19³/₈"H**72"W
66"W
60"W
48"W**MODEL****HT72ND**
HT66ND
HT60ND
HT48ND**SHIP WEIGHT**26.0
24.0
22.0
18.0**CUBE**2.3
2.1
1.9
1.5**LIST PRICE****\$505**
\$486
\$470
\$420

Specify: Model.Fabric.Paint. Upcharges may apply to premium fabric grades.

! Disperse (DISP) fabric not available on sizes wider than 60".

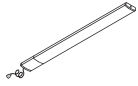

OPEN MARKET

LED Task Lights17" LED Light with Power Supply (Single)
31" LED Light with Power Supply (Single)**HLED17AS**
HLED31AS1.2 Ⓢ
1.5 Ⓢ0.05
0.09**\$420**
\$56517" LED Light with Power Supply for Daisy-chain (Starter)
31" LED Light with Power Supply for Daisy-chain (Starter)**HLED17A**
HLED31A1.0 Ⓢ
1.4 Ⓢ0.05
0.09**\$462**
\$62017" LED Light with 8" Jumper Cord for Daisy-chain (Follower)
31" LED Light with 8" Jumper Cord for Daisy-chain (Follower)**HLED17AUO**
HLED31AUO1.0 Ⓢ
1.0 Ⓢ0.03
0.05**\$377**
\$502**Undercabinet Occupancy Sensor with 1" End to End Connector****HLEDOSA**

0.2 Ⓢ

0.01

\$89

NOTES: To use the daisy chain application, must start with model HLED17A or HLED31A. No finish specification required. Attaches magnetically to underside of overhead storage, or attaches with provided screws or double-sided tape. Occupancy sensor attaches to a single or starter LED light and will automatically turn the light off after no motion is detected for 30 minutes. Just like all the LED light models, the occupancy sensor features a soft-touch on/off switch. LED task lights have a lifetime of 50,000 hours and have a dimmer feature that allows the user to adjust the amount of light output. For additional information see page 842.

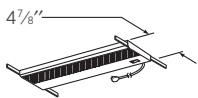

Refer to page 842

OPEN MARKET

Recessed Task Light for use under 72", 66" and 60"W Stack-on or Open Shelf46¹/₂"W x 3¹/₁₆"D x 1¹/₈"H**HH870960**

12.0 Ⓢ

1.1

\$270

NOTES: For additional information see page 842.

Recessed Task Light for use under 48"W Stack-on or Open Shelf34⁵/₈"W x 3¹/₁₆"D x 1¹/₈"H**HH870942**

10.0 Ⓢ

0.9

\$250

NOTES: For additional information see page 842.



SIN 33721

Articulating Desk Lamp**Articulating Desk Lamp w/ Occupancy Sensor****HLED1**

1.2 Ⓢ

6.5

\$402**HLED10C**

1.2 Ⓢ

6.5

\$490

NOTES: For additional information see page 841.



SIN 33721

Task Desk Lamp

NOTES: For additional information see page 841.

HLED2

0.7 Ⓢ

3.0

\$348**NOTES:**

- See specifying information above for Choice/Metallic paint and pages 16 and 362 for Custom Paint ordering instructions.
- feature painted steel backs and can be installed in the field.

HOW TO SPECIFYSelect
Model Number

H T 7 2 N D .

Select
Fabric Color

See pages 25-26

A P N 1 5 .

Select
Paint Color

See page 362

P

ABODE™



Abode™ shown with Contain® Storage and Endorse® Seating.

ABODE™

The Abode systems desk gives you a consistent look throughout your space and can help you respond easily to future layout changes. It integrates seamlessly with Abound and Accelerate, and can be configured to create freestanding or height adjustable workstations. For greater flexibility and durability in the workspace, look no further than Abode.



FEATURES

- Create a freestanding metal desk that accommodates storage above and below the worksurface.
- Full compatibility with Abound and Accelerate workstations elevates the functionality of Abode.
- Incorporating Coordinate™ makes it easy for workers to adjust their desk height throughout the day, keeping them active, healthy and focused.

ABODE™ ORDERING INFORMATION

WORKSURFACES, COUNTERTOPS, CORNER SHELVES W/EDGEBAND

L1 LAMINATES CODES

Woodgrain

- ◆ Bourbon Cherry H
- ◆ Cognac COGN
- ◆ Florence Walnut LFW1
- ◆ Harvest C
- ◆ Kingswood Walnut LK11
- ◆ Mahogany N
- ◆ Mocha MOCH
- ◆ Natural Maple D
- ◆ Pinnacle PINC
- ◆ Shaker Cherry F
- ◆ Sterling Ash LSA1

Solid

- ◆ Black P
- ◆ Charcoal S
- ◆ Designer White LDW1
- ◆ Loft LOFT

Patterned

- ◆ Sheer Mesh A5
- ◆ Silver Mesh B9
- ◆ Steel Mesh A9
- ◆ Canyon Zephyr K9
- ◆ Desert Zephyr K8
- ◆ Shadow Zephyr K1
- ◆ Gray G2
- ◆ Grey Tigris L6
- ◆ White G1
- ◆ Whitestone K4

L2 LAMINATES CODES

Woodgrain

- ◆ Lowell Ash LLA1
- ◆ Natural Recon LNR1
- ◆ Phantom Ecru LPE1
- ◆ Portico Teak LPT1
- ◆ Skyline Walnut LSW1

(Door panels not available in L2)

WORKSURFACE EDGE BAND

- ◆ Black P
- ◆ Bourbon Cherry H
- ◆ Charcoal S
- ◆ Cognac COGN
- ◆ Designer White LDW1
- ◆ Florence Walnut LFW1
- ◆ Greige T5
- ◆ Harvest C
- ◆ Kingswood Walnut LK11
- ◆ Light Gray Q
- ◆ Loft LOFT
- ◆ Lowell Ash LLA1
- ◆ Mahogany N
- ◆ Mocha MOCH
- ◆ Muslin T3
- ◆ Natural Maple D
- ◆ Natural Recon LNR1
- ◆ Phantom Ecru LPE1
- ◆ Pinnacle PINC
- ◆ Platinum PLAT
- ◆ Portico Teak LPT1
- ◆ Shadow* SHDW
- ◆ Shaker Cherry F
- ◆ Skyline Walnut LSW1
- ◆ Sterling Ash SA

WORKSURFACE GROMMET

- ◆ Black P
- ◆ Brownstone EY
- ◆ Charcoal S
- ◆ Fossil EH
- ◆ Greige T5
- ◆ Light Gray Q
- ◆ Loft LOFT
- ◆ Muslin T3
- ◆ Shadow* SHDW
- ◆ Titanium T1
- ◆ Designer White DW
- ◆ Champagne Metallic T4
- ◆ Platinum Metallic T1

FRAMES, TRIM, METAL TILES, CUSTOM BRACKET KIT, WORKSURFACE SUPPORTS, STEEL OVERHEAD STORAGE CHASSIS

PAINT CODES

P1

- ◆ Black P
- ◆ Brownstone P7D
- ◆ Charcoal S
- ◆ Designer White PJW
- ◆ Fossil P28
- ◆ Greige T5
- ◆ Light Gray Q
- ◆ Loft LOFT
- ◆ Muslin T3
- ◆ Putty L
- ◆ Shadow* SHDW
- ◆ Titanium P8T

P2

- ◆ Champagne Metallic T4
- ◆ Platinum Metallic T1
- ◆ Silver PR6

DUPLEX/PORTED TILE

PLASTIC CODES

- ◆ Black P
- ◆ Charcoal S
- ◆ Designer White DW
- ◆ Loft LOFT
- ◆ Muslin T3
- ◆ Titanium T1

Recommendations

Paint	Duplex-Data Code
Black P	Black P
Brownstone P7D	Brownstone EY
Charcoal S	Charcoal S
Designer White PJW	Designer White DW
Fossil P28	Charcoal S
Greige T5	Muslin T3
Light Gray Q	Loft LOFT
Loft LOFT	Loft LOFT
Muslin T3	Muslin T3
Putty L	Black P
Shadow SHDW	Muslin T3
Silver PR6	Titanium T1
Titanium P8T	Titanium T1
Champagne Metallic T4	Muslin T3
Platinum Metallic T1	Titanium T1

► LAMINATE TOPS

SPECIFY: Model Number,
Laminate
Edge Color
Grommet Color
EXAMPLE: HWR2424P.K&R.T5

► PAINTED PRODUCTS

SPECIFY: Model Number,
Paint Color
EXAMPLE: HRVSHV24.T1

◆◆◆ For lead time information see page 19.

* De-emphasized

Edge Treatments

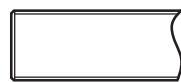

"P" Edgeband

(Color must be selected.)

WORKING WITH ABODE™ COMPONENTS

Configurations

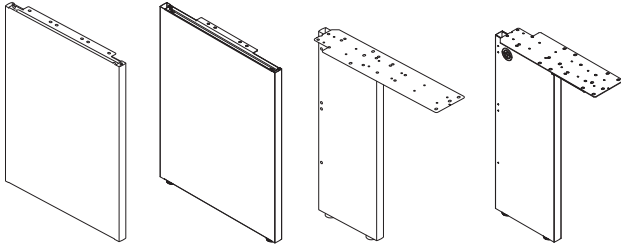

End Panels and Support Legs

Each are available in two options: freestanding or panel mount. The only difference between the two options are the panel-mount models come with a left- or right-handed bracket to attach the support to a panel in a systems application.

The 11"D end panel is used to support peninsulas.

Corner Desk Legs

Corner desk legs have a 90-degree bend and welded construction. The strong construction allows gussets or half-height modesty panels to be used with corner legs.

Bridge Kits

Bridge kits include: two flat brackets, two modesty panel-to-end panel attachment brackets, and two tie straps. This kit is used when attaching a bridge unit between two rectangular worksurfaces.

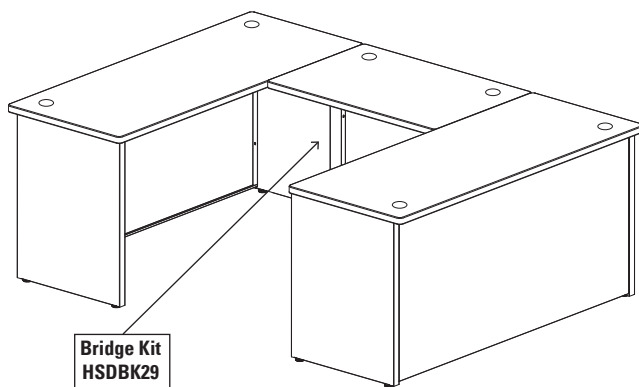

There are some bridge instances where only half of a bridge kit is needed (e.g., using a bridge between a rectangular worksurface and a corner or peninsula). A return kit may be ordered for these instances.

Support Column

Support columns are used to support one end of curvilinear worksurfaces. Includes column, worksurface bracket kit HWSA2, attaching hardware, and adjustable glides.

Return Kits

Return kits include: one flat bracket, one modesty panel-to-end panel attachment bracket, and one tie strap. These are used when attaching a return to a primary desk. Return kits can also be used in some bridge applications — one example is shown below when using a peninsula.

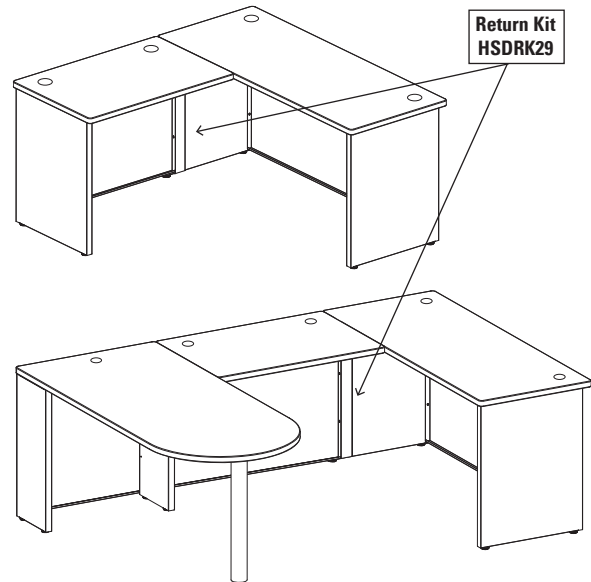

Desk-to-Panel Attachment Kits

Desk-to-panel attachment kits are used to connect a worksurface and modesty panel perpendicular to a panel of corresponding width. Opposing end of worksurface must be attached with an end panel, support leg, or corner leg mounted directly under this worksurface.

When using a corner or corner cove worksurface with the rear corner attached to a panel, and opposing end of worksurface is attached to a freestanding desk, use corner w/desk attachment kit. Hand of unit is determined from the user's side of the desk (right-hand unit attaches to right side of modesty).

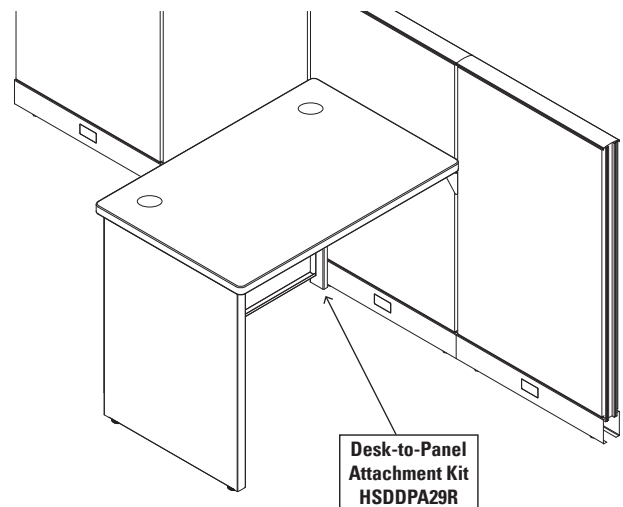

Corner w/Desk Panel Attachment Kit

Corner w/desk panel attachment kit connects the rear corner of a corner or corner cove worksurface and modesty panel to a panel when the opposing end of the worksurface shares a support leg with an adjacent freestanding desk and the support leg is mounted under the freestanding desk. Hand of unit is determined from the user's side of the desk (left-hand unit attaches to left side of modesty).

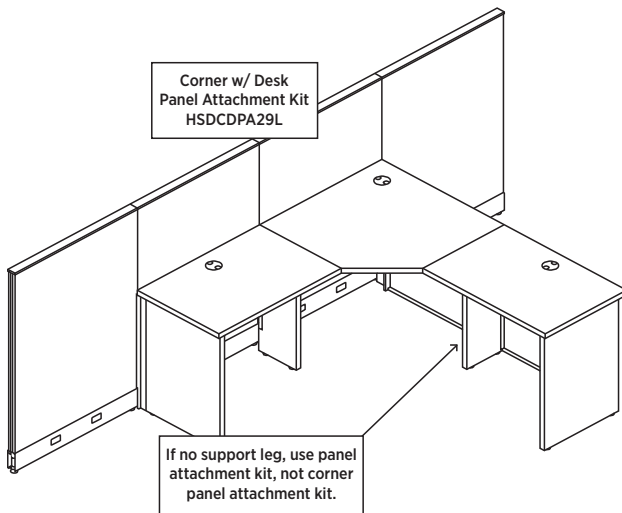

Corner Worksurfaces

Corner worksurfaces accommodate 90-degree corner desk legs.

In-Line Connections of Desks

Shared leg can be used at in-line connections to support adjacent rectangular desks.

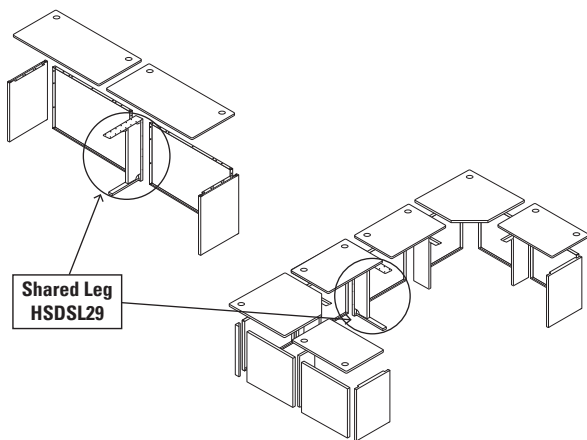

Pedestals and Storage

Pedestals must be ordered smaller than the depth of the worksurface. For example, 18" D peds should be used with 24" D worksurfaces. 18" D or 23" D pedestals can be used with 30" D worksurfaces. Using 18" D laterals or personal files provide additional storage options under 24" D worksurfaces.

Modesty Panels

The following are some general guidelines for Abode™ modesty panels:

- **Desk:** Modesty panel width is the same width as the worksurface
- **Return:** Modesty panel width is 6" greater than the width of the worksurface
- **Bridge connecting two rectangular worksurfaces:** Modesty panel width is 12" greater than the width of the bridge worksurface
- **Bridge connecting a rectangular worksurface and corner or peninsula:** Modesty panel width is 6" greater than the width of the worksurface
- **Corner connecting to an adjacent worksurface:** Modesty panel width is the same width as the worksurface.

Stand-Alone Corner Modesty Panels

Stand-alone corner modesty panels are used only when one or both sides of a corner or corner cove worksurface are freestanding and NOT attached to another worksurface. Specify the width the same as the width of the worksurface.

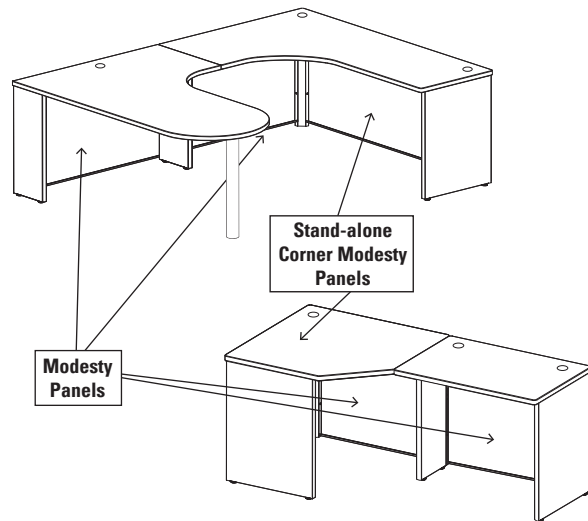

Gussets "G"

Gussets can be used in place of a modesty panel with desks 36" W to 60" W. Gussets can also be used with corner desk legs.

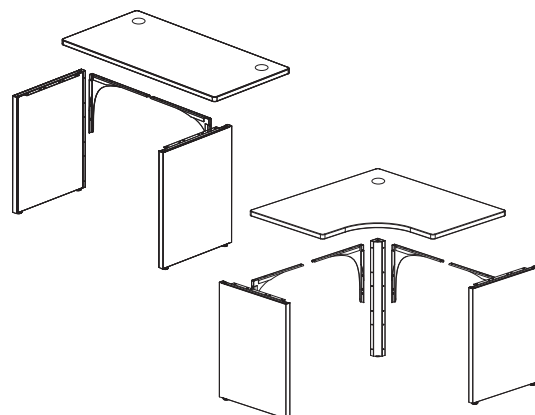



Icon Legend on page 19

The following five pages contain examples of Abode™ workstations. Each “typical” is shown in 3D hidden line perspective. Along with each typical is a complete listing of all the components. Use the information and format to better understand the layout and specifying of Abode™.

QTY	DESCRIPTION	MODEL	LIST PRICE	PRICE EXTENSION
1	Rectangle Worksurface 24”D x 36”W	HWR2436P	\$346	\$346
2	Freestanding End Panel Support 24”D x 29½”H	HSDEP2429F	\$194	\$388
1	Full-Height Modesty Panel 36”W x 29½”H	HSDMP369	\$183	\$183
TOTAL:				\$917

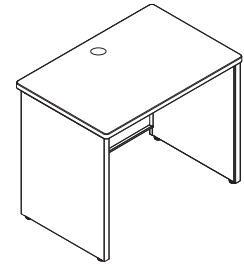

FREESTANDING DESK

QTY	DESCRIPTION	MODEL	LIST PRICE	PRICE EXTENSION
1	Rectangle Worksurface 24”D x 36”W	HWR2436P	\$346	\$346
1	Freestanding End Panel Support 24”D x 29½”H	HSDEP2429F	\$194	\$194
1	Full-Height Modesty Panel 36”W x 29½”H	HSDMP369	\$183	\$183
1	Desk-to-Panel Attachment Kit – Right-Handed 29½”H	HSDPPA29R	\$97	\$97
TOTAL:				\$820

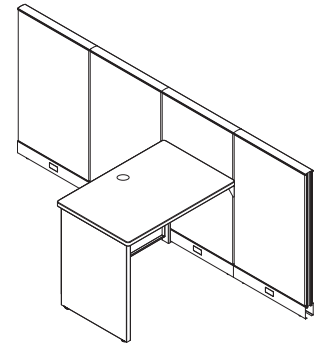

PANEL-ATTACHED DESK

QTY	DESCRIPTION	MODEL	LIST PRICE	PRICE EXTENSION
1	Rectangle Worksurface 24”D x 36”W	HWR2436P	\$346	\$346
1	Rectangle Worksurface 24”D x 60”W	HWR2460P	\$477	\$477
1	Full-Height Modesty Panel 42”W x 29½”H	HSDMP429	\$187	\$187
3	Freestanding End Panel Support 24”D x 29½”H	HSDEP2429F	\$194	\$582
1	Return Kit 29½”H	HSDRK29	\$100	\$100
1	Full-Height Modesty Panel 60”W x 29½”H	HSDMP609	\$199	\$199
TOTAL:				\$1,891

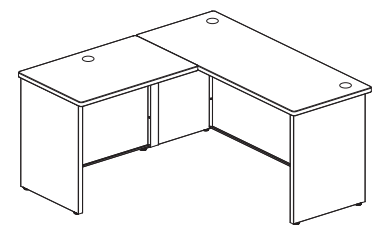

RETURN DESK

Attached to a primary or return desk

QTY	DESCRIPTION	MODEL	LIST PRICE	PRICE EXTENSION
1	Rectangle Worksurface 24”D x 48”W	HWR2448P	\$404	\$404
1	Full-Height Modesty Panel 54”W x 29½”H	HSDMP549	\$197	\$197
1	Freestanding End Panel Support 24”D x 29½”H	HSDEP2429F	\$194	\$194
1	Return Kit 29½”H	HSDRK29	\$100	\$100
1	End Panel Support – Right 24”D x 29½”H	HRVEP2429R	\$223	\$223
1	End Panel Support – Left 24”D x 29½”H	HRVEP2429L	\$223	\$223
1	Rectangle Worksurface 24”D x 60”W	HWR2460P	\$477	\$477
TOTAL:				\$1,818

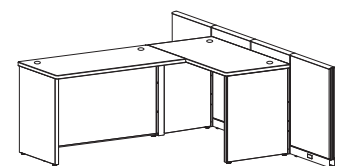

RETURN DESK

Attached to a panel-hung worksurface



QTY	DESCRIPTION	MODEL	LIST PRICE	PRICE EXTENSION
1	Rectangle Worksurface 24"D x 42"W	HWR2442P	\$380	\$380
2	Rectangle Worksurface 24"D x 72"W	HWR2472P	\$529	\$1,058
1	Full-Height Modesty Panel 54"W x 29½"H	HSDMP549	\$197	\$197
1	Bridge Kit	HSDBK29	\$193	\$193
2	Full-Height Modesty Panel 72"W x 29½"H	HSDMP729	\$206	\$412
4	Freestanding End Panel Support 24"D x 29½"H	HSDEP2429F	\$194	\$776
TOTAL:				\$3,016

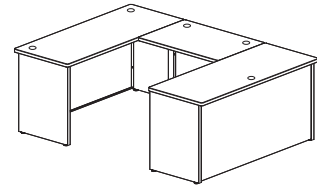

BRIDGE DESK

Attached between two primary desks

QTY	DESCRIPTION	MODEL	LIST PRICE	PRICE EXTENSION
1	Rectangle Worksurface 24"D x 36"W	HWR2436P	\$346	\$346
1	Rectangle Worksurface 24"D x 60"W	HWR2460P	\$477	\$477
1	Peninsula Worksurface 30"D x 60"W	HWP3060P	\$629	\$629
1	Full-Height Modesty Panel 42"W x 29½"H	HSDMP429	\$187	\$187
1	Full-Height Modesty Panel 30"W x 29½"H	HSDMP309	\$181	\$181
2	Freestanding End Panel Support 24"D x 29½"H	HSDEP2429F	\$194	\$388
1	Full-Height Modesty Panel 60"W x 29½"H	HSDMP609	\$199	\$199
1	Freestanding End Panel Support 11"D x 29½"H	HSDEP1129F	\$183	\$183
1	Freestanding Support Leg 24"D x 29½"H	HSDSL2429F	\$203	\$203
1	Support Column for Peninsula	HCNLEG29	\$217	\$217
1	Return Kit 29½"H	HSDRK29	\$100	\$100
TOTAL:				\$3,110

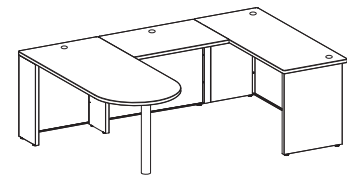

BRIDGE DESK AND PENINSULA

Attached to a primary desk

QTY	DESCRIPTION	MODEL	LIST PRICE	PRICE EXTENSION
1	Corner Worksurface 24"D x 36"W	HWCS3624P	\$522	\$522
2	Stand-Alone Corner Modesty Panel 36"W x 29½"H	HSDCMP3629	\$183	\$366
2	Freestanding End Panel Support 24"D x 29½"H	HSDEP2429F	\$194	\$388
1	Corner Desk Leg 29½"H	HSDDL29	\$165	\$165
TOTAL:				\$1,441

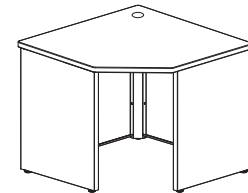

CORNER DESK

Stand-alone

QTY	DESCRIPTION	MODEL	LIST PRICE	PRICE EXTENSION
1	Corner Worksurface 24"D x 36"W	HWCS3624P	\$522	\$522
1	Rectangle Worksurface 24"D x 36"W	HWR2436P	\$346	\$346
1	Stand-Alone Corner Modesty Panel 36"W x 29½"H	HSDCMP3629	\$183	\$183
2	Full-Height Modesty Panel 36"W x 29½"H	HSDMP369	\$183	\$366
2	Freestanding End Panel Support 24"D x 29½"H	HSDEP2429F	\$194	\$388
1	Freestanding Support Leg 24"D x 29½"H	HSDSL2429F	\$203	\$203
1	Corner Desk Leg 29½"H	HSDDL29	\$165	\$165
TOTAL:				\$2,173

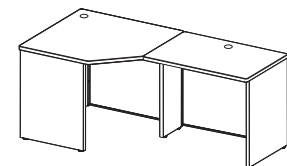

CORNER DESK

With adjacent desk attached at one side



Icon Legend on page 19

ABODE™ Typicals

QTY	DESCRIPTION	MODEL	LIST PRICE	PRICE EXTENSION
2	Rectangle Worksurface 24"D x 36"W	HWR2436P	\$346	\$692
1	Rectangle Worksurface 24"D x 72"W	HWR2472P	\$529	\$529
1	Corner Worksurface 24"D x 36"W	HWCS3624P	\$522	\$522
1	Full-Height Modesty Panel 42"W x 29½"H	HSDMP429	\$187	\$187
1	Return Kit 29½"H	HSDRK29	\$100	\$100
2	Freestanding Support Leg 24"D x 29½"H	HSDSL2429F	\$203	\$406
3	Freestanding End Panel Support 24"D x 29½"H	HSDEP2429F	\$194	\$582
1	Full-Height Modesty Panel 72"W x 29½"H	HSDMP729	\$206	\$206
3	Full-Height Modesty Panel 36"W x 29½"H	HSDMP369	\$183	\$549
1	Corner Desk Leg 29½"H	HSDDL29	\$165	\$165
TOTAL:			\$3,938	

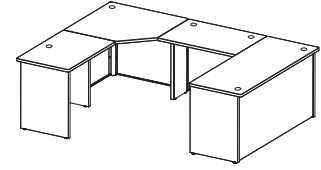

BRIDGE DESK

Attached between corner and primary desk

QTY	DESCRIPTION	MODEL	LIST PRICE	PRICE EXTENSION
1	Jetty – Right-Handed 48"D x 72"W x 24" x 30"	HWJ59ABRP	\$843	\$843
1	Corner Cove – Right-Handed 72" x 48" x 24" x 24"	HWV95AARP	\$834	\$834
2	Full-Height Modesty Panel 48"W x 29½"H	HSDMP489	\$194	\$388
1	Stand-Alone Corner Modesty Panel 72"W x 29½"H	HSDCMP7229	\$206	\$206
1	Freestanding End Panel Support 11"D x 29½"H	HSDEP1129F	\$183	\$183
1	Freestanding Support Leg 24"D x 29½"H	HSDSL2429F	\$203	\$203
1	Freestanding End Panel Support 24"D x 29½"H	HSDEP2429F	\$194	\$194
1	Corner Desk Leg 29½"H	HSDDL29	\$165	\$165
1	Support Column	HCNLEG29	\$217	\$217
TOTAL:			\$3,233	

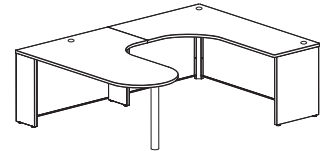

"U" WITH JETTY AND CORNER COVE

QTY	DESCRIPTION	MODEL	LIST PRICE	PRICE EXTENSION
4	Rectangular Worksurface 24"D x 72"W	HWR2472P	\$529	\$2,116
2	Abound® Panel Frame 35"H x 24"W	HRVF3524P	\$232	\$464
2	Abound® Panel Frame 35"H x 48"W	HRVF3548P	\$267	\$534
4	Abound® Fabric Tile 30"H x 24"W	HRVT3024T	\$99	\$396
4	Abound® Fabric Tile 30"H x 48"W	HRVT3048T	\$136	\$544
2	Abound® Frameless Glass 7½"H x 72"W	HRVT0772F	\$835	\$1,670
2	Abound® Finished End Trim 30"H	HRVC30PF	\$76	\$152
2	Abode™ Desk-to-Panel Attachment Kits – Left 29½"H	HSDDPA29L	\$97	\$194
2	Abode™ Desk-to-Panel Attachment Kits – Right 29½"H	HSDDPA29R	\$97	\$194
4	Abode™ Full-Height Modesty Panel 72"W	HSDMP729	\$206	\$824
4	Abode™ Freestanding End Panel 24"D	HSDEP2429F	\$194	\$776
2	Contain® Low Credenza, Box/Lateral – Right 48"W	HSCBX224818RBFOMA	\$1,598	\$3,196
2	Contain® Low Credenza, Box/Lateral – Left 48"W	HSCBX224818LBFOMA	\$1,598	\$3,196
4	Flagship® Freestanding Support Ped B/B/F	H19717A	\$668	\$2,672
4	Voi® Above Privacy Screen 60"W x 13"H	HLSL1260	\$453	\$1,812
4	Credenza Storage-to-Panel Bracket	HSCAPB	\$195	\$780
TOTAL:			\$19,520	

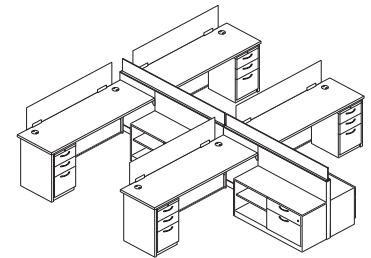

ABODE™ WITH ABOUND®

ABODE™ Typicals



Icon Legend on page 19

QTY	DESCRIPTION	MODEL	LIST PRICE	PRICE EXTENSION
2	Rectangular Worksurface 24"D x 36"W	HWR2436P	\$346	\$692
1	Corner Worksurface 24"D x 36"W	HWCS3624P	\$522	\$522
2	Abode™ Freestanding End Panel 24"D	HSDEP2429F	\$194	\$388
2	Abode™ Freestanding Support Leg 24"D	HSDSL2429F	\$203	\$406
1	Abode™ Corner Desk Leg 29½"H	HSDDL29	\$165	\$165
4	Abode™ Full-Height Modesty Panel 36"W	HSDMP369	\$183	\$732
2	Flagship® Freestanding Support Ped B/B/F	H19717A	\$668	\$1,336
TOTAL:			\$4,241	

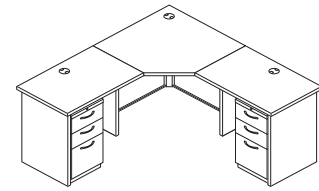

CORNER WITH RETURN

QTY	DESCRIPTION	MODEL	LIST PRICE	PRICE EXTENSION
8	Accelerate® Tackable Panel 65"H x 24"W	HETP6524FP	\$366	\$2,928
2	Accelerate® Tackable Panel 65"H x 48"W	HETP6548FP	\$470	\$940
6	Accelerate® Top Cap 24"W	HETC24	\$36	\$216
2	Accelerate® Top Cap 72"W	HETC72	\$100	\$200
4	Rectangular Worksurface 24"D x 72"W	HWR2472P	\$529	\$2,116
4	Rectangular Worksurface 24"D x 48"W	HWR2448P	\$404	\$1,616
2	Accelerate® "T" Connector 65"H	HEC65PT	\$155	\$310
1	Accelerate® "X" Connector 65"H	HEC65PX	\$155	\$155
6	Accelerate® Panel Finished End Covers 65"H	HEFEC65P	\$63	\$378
8	Accelerate® Worksurface Bracket Kit	HWSB2	\$46	\$368
4	Flat Bracket 24"D	HHN831124	\$64	\$256
4	Flagship® Freestanding Support Ped B/B/F	H19717A	\$668	\$2,672
2	Abode™ Desk-to-Panel Attachment Kits - Left 29½"H	HSDDPA29L	\$97	\$194
2	Abode™ Desk-to-Panel Attachment Kits - Right 29½"H	HSDDPA29R	\$97	\$194
4	Abode™ Freestanding End Panel 24"D	HSDEP2429F	\$194	\$776
4	Abode™ Full-Height Modesty Panel 72"W	HSDMP729	\$206	\$824
4	Systems Overhead Storage Flipper Door 48"W	HRVOH48FM	\$632	\$2,528
4	Systems Overhead Storage Shelf 24"W	HRVSH24	\$233	\$932
4	Voi® Above Privacy Screen 42"W x 13"H	HLSL1242	\$344	\$1,376
TOTAL:			\$18,979	

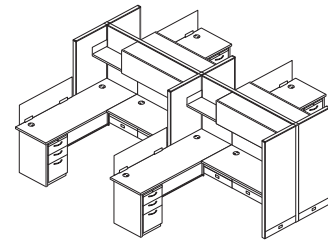

ABODE™ WITH ACCELERATE®

QTY	DESCRIPTION	MODEL	LIST PRICE	PRICE EXTENSION
1	Rectangular Worksurface 24"D x 72"W	HWR2472P	\$529	\$529
1	Rectangular Worksurface 24"D x 48"W	HWR2448P	\$404	\$404
1	Peninsula Worksurface 30"D x 72"W	HWP3072P	\$760	\$760
1	Stack-on Full Clearance w/o Doors 13"D x 72"W x 34¾"H	H386572N	\$908	\$908
1	Flipper Doors w/ Lock 36"W x 16"H	H387215	\$564	\$564
1	for 72"W Hutch 72"	HT72ND	\$505	\$505
1	Support Column for Peninsula 29"H	HCNLEG29	\$217	\$217
2	Abode™ Freestanding End Panel 24"D	HSDEP2429F	\$194	\$388
1	Abode™ Freestanding End Panel 11"D	HSDEP1129F	\$183	\$183
1	Abode™ Freestanding Support Leg 24"D	HSDSL2429F	\$203	\$203
1	Abode™ Return Kit	HSDRK29	\$100	\$100
1	Abode™ Full-Height Modesty Panel 72"W	HSDMP729	\$206	\$206
1	Abode™ Full-Height Modesty Panel 54"W	HSDMP549	\$197	\$197
1	Abode™ Full-Height Modesty Panel 30"W	HSDMP309	\$181	\$181
1	Flagship® 2 Drawer "A" Pull Lateral 30"W	H9170A	\$960	\$960
TOTAL:			\$6,305	

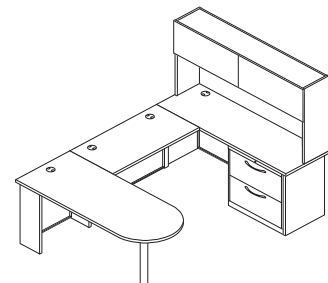

PENINSULA U



Icon Legend on page 19

ABODE™ Typicals

WORKSTATIONS

QTY	DESCRIPTION	MODEL	LIST PRICE	PRICE EXTENSION
2	Rectangular Worksurface 24"D x 72"W	HWR2472P	\$529	\$1,058
1	Height Adjustable Worksurface 24"D x 48"W	HHAW2448P	\$429	\$429
1	Stack-on Full Clearance w/o Doors 13"D x 72"W x 34¾"H	H386572N	\$908	\$908
1	Flipper Doors w/ Lock 36"W x 16"H	H387215	\$564	\$564
1	for 72"W Hutch 72"	HT72ND	\$505	\$505
2	Abode™ Full-Height Modesty Panel 72"W	HSDMP729	\$206	\$412
4	Abode™ Freestanding End Panel 24"D	HSDEP2429F	\$194	\$776
1	Systems Height Adjustable Base 24"D	HHAB3S2L	\$1,120	\$1,120
2	Flagship® 2 Drawer "A" Pull Lateral 30"W	H9170A	\$960	\$1,920
TOTAL:			\$7,692	

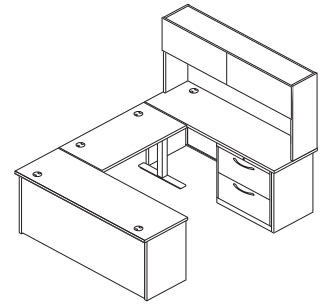

WORKSTATION U

ABODE™ Components

GSA SIN 33721



Icon Legend on page 19

WORKSTATIONS

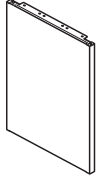

DESCRIPTION	MODEL	SHIP WEIGHT	CUBE	LIST PRICE BY PAINT GRADE	
				P1	P2
Freestanding End Panel Supports					
11"D	HSDEP1129F	15	1.1	\$183	\$210
24"D	HSDEP2429F	25	1.1	\$194	\$221
30"D	HSDEP3029F	30	1.1	\$216	\$243

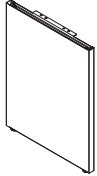

Panel Mounted Full End Panel Supports*					
29½"H x 11"D — Right — Panel Mount	HRVEP1129R	16	1.4	\$207	\$236
29½"H x 11"D — Left — Panel Mount	HRVEP1129L	16	1.4	\$207	\$236
29½"H x 24"D — Right — Panel Mount	HRVEP2429R	21	1.4	\$223	\$252
29½"H x 24"D — Left — Panel Mount	HRVEP2429L	21	1.4	\$223	\$252
29½"H x 30"D — Right — Panel Mount	HRVEP3029R	23	1.4	\$242	\$271
29½"H x 30"D — Left — Panel Mount	HRVEP3029L	23	1.4	\$242	\$271

*Must be connected into panel slots. When an installation of worksurfaces is 8 feet or greater, a full end panel or universal support leg must be used at 90 degree panel junctions or in a shared position to support adjoining worksurfaces.

Specify paint

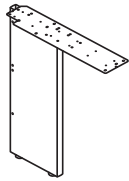

Freestanding Support Leg					
24"D	HSDSL2429F	25	1.1	\$203	\$230
30"D	HSDSL3029F	25	1.1	\$230	\$257

NOTES: To be used when connecting a non-rectangular worksurface to a rectangular worksurface.

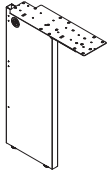

Panel Mounted Support Leg*					
29½"H to support 24"D	HRVCLG24	16	1.4	\$197	\$226
29½"H to support 30"D	HRVCLG30	17	1.4	\$215	\$244

*Must be connected into panel slots. When an installation of worksurfaces is 8 feet or greater, a full end panel or universal support leg must be used at 90 degree panel junctions or in a shared position to support adjoining worksurfaces.

Non-handed unit
Specify paint









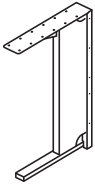

NOTES:

All Abode™ Components are compatible with Abound® and Accelerate® panel systems and Systems Worksurfaces.

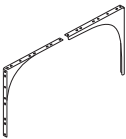
HOW TO SPECIFY

<p>Select Model Number</p> <p>HSDEP1129F . T1</p>	<p>Select Paint Color</p> <p>See page 378</p>
---	---



	DESCRIPTION	MODEL	SHIP WEIGHT	CUBE	LIST PRICE BY PAINT GRADE	
					P1	P2
	Abode™ Shared Leg NOTES: To be used when joining two rectangular surfaces. Can be used as a stand-alone support in panel systems. 1½" radius opening for cord management.	HSDSL29	18 	1.5	\$372	\$399
	Corner Desk Leg 29½"H NOTES: Corner desk legs have 90° bend and welded construction.	HSDDL29	7 	0.4	\$165	\$192
	Gussets (1 pair) NOTES: Gussets may be used instead of a modesty panel to create freestanding desks 36"W to 60"W.	HSDG	7 	0.5	\$114	\$131
	Flat Bracket 24"D 30"D  Charcoal only.	HHN831124 HHN831130	3  3 	0.3 0.4	\$64 \$64	N/A N/A

NOTES:

 All Abode™ Components are compatible with Abound® and Accelerate® panel systems and Systems Worksurfaces.

EXTERNAL CHANNEL SELECTION GUIDE						
Support Combination		Worksurface Width for Rectangle, Wedge, and Saddle				
Support 1	Support 2	84 in	72 in	66 in	60 in	54 in
O-Leg	O-Leg	NA	HLSLZ5SC72	HLSLZ5SC66	HLSLZ5SC60	HLSLZ5SC54
O-Leg	Slim Profile Pedestal	HLSLZ5SC84	HLSLZ5SC66	HLSLZ5SC60	HLSLZ5SC54	NA
O-Leg	Bookcase	HLSLZ5SC72	HLSLZ5SC66	HLSLZ5SC60	HLSLZ5SC54	NA
O-Leg	Pedestal	HLSLZ5SC72	HLSLZ5SC60	HLSLZ5SC54	NA	NA
O-Leg	End-Panel	HLSLZ5SC84	HLSLZ5SC60	HLSLZ5SC54	NA	NA
Slim Profile Pedestal	Slim Profile Pedestal	HLSLZ5SC72	HLSLZ5SC60	HLSLZ5SC54	NA	NA
Slim Profile Pedestal	Bookcase	HLSLZ5SC72	HLSLZ5SC60	HLSLZ5SC54	NA	NA
Slim Profile Pedestal	Pedestal	HLSLZ5SC66	HLSLZ5SC54	NA	NA	NA
Slim Profile Pedestal	End-Panel	HLSLZ5SC66	HLSLZ5SC54	NA	NA	NA
Pedestal	Bookcase	HLSLZ5SC66	HLSLZ5SC54	NA	NA	NA
End-Panel	Bookcase	HLSLZ5SC66	HLSLZ5SC54	NA	NA	NA
Bookcase	Bookcase	HLSLZ5SC66	HLSLZ5SC54	NA	NA	NA
End-Panel	End-Panel	HLSLZ5SC60	NA	NA	NA	NA
Pedestal	Pedestal	HLSLZ5SC60	NA	NA	NA	NA
Pedestal	End-Panel	HLSLZ5SC60	NA	NA	NA	NA
O-Leg	Lateral/Multifile	HLSLZ5SC54	NA	NA	NA	NA
Bookcase	Lateral/Multifile	NA	NA	NA	NA	NA
Slim Profile Pedestal	Lateral/Multifile	NA	NA	NA	NA	NA
Pedestal	Lateral/Multifile	NA	NA	NA	NA	NA
End-Panel	Lateral/Multifile	NA	NA	NA	NA	NA

*All Rudder worksurfaces use external channel model HLSLZ5SC60.

HOW TO SPECIFY

<p>Select Model Number</p> <p>H S D S L 2 9</p>	<p>Select Paint Color</p> <p>See page 378</p> <p>T 1</p>
--	---

ABODE™ Components

GSA SIN 33721



Icon Legend on page 19

WORKSTATIONS

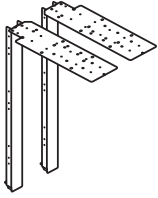

DESCRIPTION

Bridge Kit
29½”H

MODEL

HSDBK29

SHIP WEIGHT

10 **Ⓢ**

CUBE

0.4

LIST PRICE BY PAINT GRADE

P1

\$193

P2

\$220

NOTES: Add 12” to your modesty width when using a Bridge Kit. Bridge Kits include two flat brackets, two modesty panel-to-end panel attachment brackets, and two tie straps.

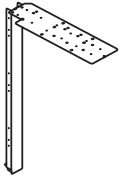

Return Kit
29½”H

HSDRK29

6 **Ⓢ**

0.4

\$100

\$127

NOTES: Add 6” to your modesty width when using a Return Kit. Return Kits include one flat bracket, one modesty panel-to-end panel attachment bracket, and one tie strap.



Desk-to-Panel Attachment Kit
29½”H
29½”H

HSDDPA29L

5 **Ⓢ**

0.3

\$97

\$107

HSDDPA29R

5 **Ⓢ**

0.3

\$97

\$107



Corner with Desk-to-Panel Attachment Kit
29½”H
29½”H

HSDCPA29L

5 **Ⓢ**

0.3

\$97

\$107

HSDCPA29R

5 **Ⓢ**

0.3

\$97

\$107

NOTES: This Attachment Kit utilizes the same modesty panel specification rules as the Freestanding Corner Leg.

HOW TO SPECIFY

Select Model Number

Select Paint Color

See page 378

H S D B K 2 9 .

T 1

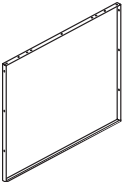

DESCRIPTION	MODEL	SHIP WEIGHT	CUBE	LIST PRICE BY PAINT GRADE	
				P1	P2
 Full-Height Modesty Panel 29½" H x 24" W 29½" H x 30" W 29½" H x 36" W 29½" H x 42" W 29½" H x 48" W 29½" H x 54" W 29½" H x 60" W 29½" H x 66" W 29½" H x 72" W	HSDMP249	5.0 Ⓢ	0.6	\$175	\$192
	HSDMP309	7.0 Ⓢ	0.6	\$181	\$198
	HSDMP369	8.0	0.8	\$183	\$200
	HSDMP429	9.0	0.9	\$187	\$204
	HSDMP489	11.0	1.0	\$194	\$211
	HSDMP549	12.0	2.2	\$197	\$214
	HSDMP609	13.0	2.2	\$199	\$216
	HSDMP669	15.0	2.6	\$203	\$220
	HSDMP729	16.0	3.0	\$206	\$223

! To be used in all applications except when connecting a Corner Leg to an End Panel or a Corner Leg to a Shared Leg.

 Full-Height Stand-Alone Corner Modesty Panel 29½" H x 36" W 29½" H x 42" W 29½" H x 48" W 29½" H x 60" W 29½" H x 72" W	HSDCMP3629	7.0	1.9	\$183	\$200
	HSDCMP4229	9.0	1.9	\$187	\$204
	HSDCMP4829	10.0	2.3	\$194	\$211
	HSDCMP6029	14.0	4.7	\$199	\$216
	HSDCMP7229	16.0	5.4	\$206	\$223

NOTES: To be used when connecting a Corner Leg to an End Panel or Shared Leg.

 Half-Height Modesty Panel 14" H x 24" W 14" H x 30" W 14" H x 36" W 14" H x 42" W 14" H x 48" W 14" H x 54" W 14" H x 60" W 14" H x 66" W 14" H x 72" W	HSDMP244	5.1 Ⓢ	0.4	\$164	\$181
	HSDMP304	6.6 Ⓢ	0.4	\$168	\$185
	HSDMP364	8.1 Ⓢ	0.5	\$170	\$187
	HSDMP424	9.6 Ⓢ	0.6	\$180	\$197
	HSDMP484	11.0 Ⓢ	0.6	\$183	\$200
	HSDMP544	13.0 Ⓢ	0.8	\$186	\$203
	HSDMP604	14.0 Ⓢ	0.8	\$188	\$205
	HSDMP664	16.0 Ⓢ	1.0	\$194	\$211
	HSDMP724	17.0 Ⓢ	1.0	\$197	\$214

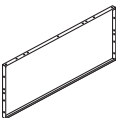
 Half-Height Stand-Alone Corner Modesty Panel 14" H x 36" W 14" H x 42" W 14" H x 48" W 14" H x 60" W 14" H x 72" W	HSDCMP3614	4.0 Ⓢ	0.5	\$170	\$187
	HSDCMP4214	4.0 Ⓢ	0.6	\$180	\$197
	HSDCMP4814	5.0 Ⓢ	0.6	\$183	\$200
	HSDCMP6014	6.0 Ⓢ	0.8	\$188	\$205
	HSDCMP7214	7.0 Ⓢ	1.0	\$197	\$214

NOTES:

- Desk: Modesty panel width is the same width as the worksurface.
- Return: Modesty panel width is 6" greater than the width of the return worksurface.
- Bridge connecting two rectangular worksurfaces: Modesty panel width is 12" greater than the width of the bridge worksurface.
- Bridge connecting a rectangular worksurface and corner or peninsula: Modesty panel width is 6" greater than the width of the worksurface.
- Corner connecting to an adjacent worksurface: Modesty panel width is the same width as the worksurface.

HOW TO SPECIFY

Select Model Number	Select Paint Color See page 378
H S D M P 2 4 9 .	T 1

ABOUND®



Abound® shown with Contain® Storage, Ignition® Seating, and Voi® Desking.

ABOUND®

High-performance workspaces? Abound set the standard, and set it high. With its mixed materials and multiple design options, Abound lets you mix and match the beautiful and the functional to customize your office — from reception areas to private offices and every space in between. Flexibility. Personality. Durability. Quality! Abound delivers all this and more.



FEATURES

- With multiple tile options, materials and fabrics, Abound supports a variety of work styles and office budgets.
- Top channel lay-in or beltline capabilities expand your cabling capacity.
- Open Base frame option brings a lighter scale aesthetic and allows for easier cleaning.
- Straight lines, crisp edges and rectilinear worksurfaces fit precisely together to create a tailored, architectural presence.
- With a variety of layout options and compatibility with HON storage, height adjustable bases and freestanding desks, the options with Abound are endless.

ABOUT® ORDERING INFORMATION

GALLERY PANELS, WORKSURFACES, COUNTERTOPS, CORNER SHELVES W/EDGE BAND, HARD-SURFACE TILE OVERHEAD STORAGE DOORS*

L1 LAMINATES CODES

Woodgrain

- ◆ Bourbon Cherry H
- ◆ Cognac COGN
- ◆ Florence Walnut LFW1
- ◆ Harvest C
- ◆ Kingswood Walnut LK11
- ◆ Mahogany N
- ◆ Mocha MOCH
- ◆ Natural Maple D
- ◆ Pinnacle PINC
- ◆ Shaker Cherry F
- ◆ Sterling Ash LSA1

Solid

- ◆ Black P
- ◆ Charcoal S
- ◆ Designer White LDW1
- ◆ Loft LOFT

Patterned

- ◆ Sheer Mesh A5
- ◆ Silver Mesh B9
- ◆ Steel Mesh A9
- ◇ Canyon Zephyr K9
- ◇ Desert Zephyr K8
- ◇ Shadow Zephyr K1
- ◆ Gray G2
- ◆ Grey Tigris L6
- ◇ White G1
- ◆ Whitestone K4

L2 LAMINATES CODES

Woodgrain

- ◆ Lowell Ash LLA1
- ◆ Natural Recon LNRI
- ◆ Phantom Ecru LPE1
- ◆ Portico Teak LPT1
- ◆ Skyline Walnut LSW1

(Door panels not available in L2)

► LAMINATE TOPS

SPECIFY: Model Number.
Laminate
Edge Color
Grommet Color

EXAMPLE: HWR2424P.K8.R.T5

► PAINTED PRODUCTS

SPECIFY: Model Number.
Paint Color

EXAMPLE: HRVSHV24.T1

► PANEL FRAMES

SPECIFY: Model Number.
Paint

EXAMPLE: HRVF3524P.T3

Suffix "A"



Satin Chrome
Arch Pull

* Laminate Front Overheads only available in L1 Woodgrain Laminates.

◆◆◆ For lead time information see page 19.

* De-emphasized

WORKSURFACE EDGE BAND

- ◆ Black P
- ◆ Bourbon Cherry H
- ◆ Charcoal S
- ◆ Cognac COGN
- ◆ Designer White LDW1
- ◆ Florence Walnut LFW1
- ◆ Greige T5
- ◆ Harvest C
- ◆ Kingswood Walnut LK11
- ◆ Light Gray Q
- ◆ Loft LOFT
- ◆ Lowell Ash LLA1
- ◆ Mahogany N
- ◆ Mocha MOCH
- ◆ Muslin T3
- ◆ Natural Maple D
- ◆ Natural Recon LNRI
- ◆ Phantom Ecru LPE1
- ◆ Pinnacle PINC
- ◆ Platinum PLAT
- ◆ Portico Teak LPT1
- ◇ Shadow * SHDW
- ◆ Shaker Cherry F
- ◆ Skyline Walnut LSW1
- ◆ Sterling Ash SA

WORKSURFACE GROMMET

- ◆ Black P
- ◆ Brownstone EY
- ◆ Charcoal S
- ◆ Fossil EH
- ◆ Greige T5
- ◆ Light Gray Q
- ◆ Loft LOFT
- ◆ Muslin T3
- ◆ Shadow * SHDW
- ◆ Titanium TI
- ◆ Designer White DW
- ◆ Champagne Metallic T4
- ◆ Platinum Metallic T1

Edge Treatments



"P" Edgeband

(Color must be selected.)

► HOW TO ORDER

- 1) Select desired model numbers.
- 2) Order worksurfaces to correspond to width of panel behind them.
- 3) Add appropriate prefix and suffix if Tee-Span worksurfaces are needed.

FRAMES, TRIM, METAL TILES, CUSTOM BRACKET KIT, WORKSURFACE SUPPORTS, STEEL OVERHEAD STORAGE CHASSIS

PAINT CODES

P1

- ◆ Black P
- ◆ Brownstone P7D
- ◆ Charcoal S
- ◆ Designer White PJW
- ◆ Fossil P28
- ◆ Greige T5
- ◆ Light Gray Q
- ◆ Loft LOFT
- ◆ Muslin T3
- ◆ Putty L
- ◆ Shadow * SHDW
- ◆ Titanium P8T

P2

- ◆ Champagne Metallic T4
- ◆ Platinum Metallic T1
- ◆ Silver PR6
- ◆ Solar Black PBX

DUPLEX/PORTED TILE

PLASTIC CODES

- ◆ Black P
- ◆ Charcoal S
- ◆ Designer White DW
- ◆ Loft LOFT
- ◆ Muslin T3
- ◆ Titanium TI

Recommendations

Paint	Duplex-Data Code
Black P	Black P
Brownstone P7D	Brownstone EY
Charcoal S	Charcoal S
Designer White PJW	Designer White DW
Fossil P28	Charcoal S
Greige T5	Muslin T3
Light Gray Q	Loft LOFT
Loft LOFT	Loft LOFT
Muslin T3	Muslin T3
Putty L	Black P
Shadow SHDW	Muslin T3
Silver PR6	Titanium TI
Titanium P8T	Titanium TI
Champagne Metallic T4	Muslin T3
Platinum Metallic T1	Titanium TI

ABOUND[®] FABRIC PATTERNS & CODES

PRICE CODE AA

FACTOR	FACT
◆ Bark	FACT20
◆ Barley	FACT15
◆ Cascade	FACT25
◆ Feather	FACT30

PRICE CODE A

APPOINT	APN
◆ Artichoke	APN11
◆ Blackberry	APN32
◆ Bronze	APN22
◆ Carbon	APN28
◆ Chai	APN12
◆ Cherry	APN30
◆ Dark Pewter	APN17
◆ Dune	APN15
◆ Espresso	APN23
◆ Framboise	APN31
◆ Frost	APN34
◆ Jet	APN27
◆ Lawn	APN25
◆ Mandarin	APN29
◆ Morel	APN09
◆ Nimbus	APN16
◆ Platinum	APN24
◆ Turquoise	APN26

CENTURION CU

Not available on heights over 54"H

◆ Apricot	CU47
◆ Bark	CU25
◆ Black	CU10
◆ Espresso	CU49
◆ Fog	CU03
◆ Frost	CU22
◆ Goldenrod	CU27
◆ Indigo	CU06
◆ Iris	CU50
◆ Iron Ore	CU19
◆ Jade	CU83
◆ Marsala	CU63
◆ Morel	CU24
◆ Navy	CU98
◆ Peacock	CU97
◆ Pear	CU84
◆ Ruby	CU67
◆ Sapphire	CU09

PRICE CODE A *continued*

ETCH*	ECH
◆ Axis	ECH13
◆ Blend	ECH14
◆ Cast	ECH12
◆ Highlight	ECH10
◆ Midtone	ECH11
◆ Outline	ECH08
◆ Shade	ECH09
◆ Tonal	ECH16
◆ Vanish	ECH15

EXCHANGE* EXG

◆ Iron	EXG916
◆ Nickel	EXG914
◆ Pistachio	EXG910
◆ Root	EXG913
◆ Rupee	EXG903
◆ Shadow	EXG911
◆ Silver	EXG915
◆ Sisal	EXG917
◆ Stone	EXG912

LANDSCAPE* LN

◆ Azure	LN55
◆ Cornsilk	LN15
◆ Drift	LN05
◆ Khaki	LN20
◆ Sheen	LN10
◆ Slate	LN35
◆ Umber	LN25
◆ Urban	LN30

LUCY* LC

◆ Aspen	LC32
◆ Cornsilk	LC30
◆ Dusk	LC22
◆ Fawn	LC33
◆ Graphite	LC34
◆ Mist	LC20
◆ Neutra	LC24
◆ Pewter	LC35
◆ Snowdrop	LC28

PRICE CODE A *continued*

REFLECTIONS*	REF
◆ Galvanized	REF29
◆ Ice	REF20
◆ Loggia	REF21
◆ Mistral	REF28
◆ Moonstone	REF23
◆ Pewter	REF22
◆ Stainless	REF24
◆ Vanilla	REF25
◆ Winter	REF27

REFUGE* RFG

◆ Artesian	RFG96
◆ Dune	RFG92
◆ Eclipse	RFG90
◆ Frost	RFG93
◆ Glacier	RFG91
◆ Mineral	RFG98
◆ Tidal	RFG94

SARTO* SRT

◆ Ash	SRT88
◆ Fog	SRT14
◆ Lemongrass	SRT49
◆ Mist	SRT45
◆ Mushroom	SRT76
◆ Oyster	SRT18
◆ Reef	SRT64
◆ Sesame	SRT93
◆ Shale	SRT52

TEMPEST* TP

◆ Dragonfly	TP30
◆ Frost	TP15
◆ Full Stream	TP80
◆ Gold Rush	TP10
◆ Slate	TP45
◆ Tumbleweed	TP70
◆ Wind Chill	TP40
◆ Zebra	TP35

NOTES: Analog, Disperse, and Exchange panel fabrics will be applied pattern cut. Disperse will not be available on 72"W panels.

◆◆◆ For lead time information see page 19.

* Directional fabrics

ABOUND® FABRIC PATTERNS & CODES

PRICE CODE B

ANALOG*	ANLG
◆ Album	ANLG06
◆ Cartridge	ANLG04
◆ Cassette	ANLG09
◆ Dial	ANLG02
◆ Media	ANLG08
◆ Reel	ANLG07
◆ Signal	ANLG03
◆ Stereo	ANLG01
◆ Track	ANLG05

COAST*	COA
◆ Channel	COA14
◆ Dune	COA03
◆ Headlands	COA10
◆ Marsh	COA02
◆ Pebble	COA12
◆ Pier	COA13
◆ Shoal	COA01
◆ Silt	COA06
◆ Tide	COA08

DISPERSE*	DISP
◆ Autumn	DISP03
◆ Branch	DISP10
◆ Coffee Bean	DISP13
◆ Dusk	DISP09
◆ Emerald City	DISP08
◆ Gold Rush	DISP02
◆ Igloo	DISP11
◆ Ink	DISP06
◆ Mist	DISP12
◆ Oatmeal	DISP15
◆ Prince	DISP07
◆ Reservoir	DISP01
◆ Rose	DISP04
◆ Spring	DISP05
◆ Steel	DISP16
◆ Taupe	DISP14

PRICE CODE B *continued*

MICA*	MCA
◆ Anthracite	MCA11
◆ Breeze	MCA18
◆ Bronze	MCA13
◆ Buff	MCA14
◆ Cremini	MCA17
◆ Crystal	MCAWIT
◆ Dew	MCA20
◆ Dove	MCA12
◆ Fresh	MCA16
◆ Mineral	MCA15
◆ Nectar	MCA19
◆ Shale	MCA10

SPIN*	SPIN
◆ Alabaster	SPIN02
◆ Cavern	SPIN03
◆ Cobblestone	SPIN04
◆ Ember	SPIN06
◆ Flame	SPIN07
◆ Heron	SPIN13
◆ Oat	SPIN01
◆ Ocean	SPIN12
◆ Plum	SPIN15
◆ Pool	SPIN11
◆ Raven	SPIN10
◆ Rhubarb	SPIN14
◆ Tropic	SPIN08
◆ Willow	SPIN05

PRICE CODE B *continued*

TERRAIN*	TRRN
◆ Bay	TRRN05
◆ Bayou	TRRN35
◆ Canyon	TRRN30
◆ Cliff	TRRN45
◆ Crest	TRRN25
◆ Delta	TRRN10
◆ Plateau	TRRN15
◆ Ridge	TRRN20
◆ Valley	TRRN40

NOTES: Disperse panel fabric is applied pattern cut and is not available on 72"W Accelerate® panels or on 66"W tackboards, Voi® screens, and Empower®.

Analog and Exchange panel fabric is applied pattern cut and is not available on 78"W tackboards, Voi® screens, and Empower®.

◆◆◆ For lead time information see page 19.

* Directional fabrics

ABOUND[®] Typicals



Icon Legend on page 19

WORKSTATIONS

QTY	DESCRIPTION	MODEL	LIST PRICE	PRICE EXTENSION
1	Flagship Series Pedestal "R" Pull Freestanding B/B/F	H19723R	\$719	\$719
1	Flagship 30"W 2-Drw "R" Pull Lateral 30"W x 28"H x 18"D	H9170R	\$960	\$960
2	Electrical Power Harness 3-1 & 2-2 Systems 36"W	HH871236	\$204	\$408
1	Circuit 1	HH873501	\$43	\$43
1	Circuit 4	HH873504	\$43	\$43
1	Base In-Feed Cable Base 3-1 & 2-2 Systems	HH879072	\$227	\$227
2	Abound Finished End Painted 65"	HRVC65PF	\$97	\$194
3	Abound L Connector Painted 65"	HRVC65PL	\$160	\$480
6	Abound Panel Frame 65"H x 36"W	HRVF6536P	\$286	\$1,716
6	Abound Top Cap Trim 36"W	HRVTC36	\$56	\$336
1	Cantilever One Pair 24"D	HCTL242	\$84	\$84
24	Abound Segment Bar 36"W	HRVFSB36	\$22	\$528
1	Abound Overhead Metal Flipper Door 36"	HRVOH36FM	\$577	\$577
24	Abound Fabric Tile 15"H x 36"W	HRVT1536T	\$72	\$1,728
12	Abound Fabric Tile 30"H x 36"W	HRVT3036T	\$99	\$1,188
1	Systems Rectangular Worksurface Edgeband 24"D x 36"W	HWR2436P	\$346	\$346
1	Systems Left Corner Cove Worksurface Edgeband 72" x 36" x 24" x 24"	HWV93AALP	\$668	\$668
TOTAL:				\$10,245

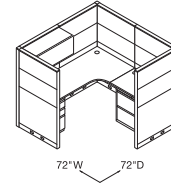

L-SHAPE WORKSTATION
72" W x 72" D

QTY	DESCRIPTION	MODEL	LIST PRICE	PRICE EXTENSION
1	Electrical Power Harness 3-1 & 2-2 Systems 48"W	HH871248	\$214	\$214
1	Circuit 1	HH873501	\$43	\$43
1	Circuit 4	HH873504	\$43	\$43
1	Base In-Feed Cable Base 3-1 & 2-2 Systems	HH879072	\$227	\$227
1	Overhead Cabinet w/Sliding Door 48"W x 14 1/4"D x 14"H	HLSL1448S	\$1,078	\$1,078
1	Mobile Ped 20" x 15 1/8" x 21 1/2"	HLSL2016MP2	\$794	\$794
1	Ped Cushion (Fabric Grade 2) 20" x 15 1/8" x 1"	HLSL2016PH2	\$333	\$333
1	Stack-on Storage Panel Mounted Bracket	HLSLPMB	\$131	\$131
2	Rectangle Worksurface 24"D x 48" W	HLSLR2448	\$300	\$600
1	Personal Storage Tower (RH) 24"D x 24"W x 65"H	HLSLW446RP	\$2,609	\$2,609
1	Abound Variable Height Finished End Painted 15"	HRVC15PFV	\$62	\$62
1	Abound Finished End Painted 50"	HRVC50PF	\$92	\$92
1	Abound L Connector Painted 50"	HRVC50PL	\$152	\$152
1	Abound Finished End Painted 65"	HRVC65PF	\$97	\$97
2	Abound L Connector Painted 65"	HRVC65PL	\$160	\$320
1	Abound Panel Frame 50"H x 24"W	HRVF5024P	\$254	\$254
1	Abound Panel Frame 50"H x 48"W	HRVF5048P	\$290	\$290
3	Abound Panel Frame 65"H x 24"W	HRVF6524P	\$276	\$828
1	Abound Panel Frame 65"H x 48"W	HRVF6548P	\$315	\$315
4	Abound Top Cap Trim 24"W	HRVTC24	\$36	\$144
2	Abound Top Cap Trim 48"W	HRVTC48	\$65	\$130
1	Flat Bracket 24"D	HHN831124	\$64	\$64
2	Abound Segment Bar 24"W	HRVFSB24	\$21	\$42
2	Abound Segment Bar 48"W	HRVFSB48	\$24	\$48
1	Abound 15" High Clear Glass Tile 15"H x 24"W	HRVT1524G	\$462	\$462
1	Abound 15" High Clear Glass Tile 15"H x 48"W	HRVT1548G	\$594	\$594
2	Abound Fabric Tile 30"H x 24"W	HRVT3024T	\$88	\$176
2	Abound Fabric Tile 30"H x 48"W	HRVT3048T	\$120	\$240
6	Abound Fabric Tile 60"H x 24"W	HRVT6024T	\$131	\$786
2	Abound Fabric Tile 60"H x 48"W	HRVT6048T	\$212	\$424
1	Bracket to Attach Towers to Worksurfaces	HSTB2W1	\$76	\$76
2	Worksurface Bracket Kit	HWSB2	\$46	\$92
TOTAL:				\$11,760

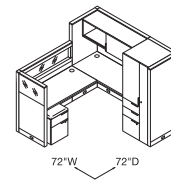

L-SHAPE WORKSTATION WITH STORAGE TOWER
72" W x 72" D



Icon Legend on page 19

ABOUND[®] Typicals

WORKSTATIONS

QTY	DESCRIPTION	MODEL	LIST PRICE	PRICE EXTENSION
2	Electrical Pass-Thru Cable 3-1 & 2-2 Systems 60"W	HH871160	\$134	\$268
1	Electrical Power Harness 3-1 & 2-2 Systems 24"W	HH871224	\$204	\$204
1	Circuit 1	HH873501	\$43	\$43
1	Circuit 2	HH873502	\$43	\$43
1	Circuit 3	HH873503	\$43	\$43
1	Circuit 4	HH873504	\$43	\$43
1	Base In-Feed Cable Base 3-1 & 2-2 Systems	HH879072	\$227	\$227
6	Abound Finished End Painted 50"	HRVC50PF	\$92	\$552
2	Abound T Connector Painted 50"	HRVC50PT	\$152	\$304
1	Abound X Connector Painted 50"	HRVC50PX	\$147	\$147
6	Abound Panel Frame 50"H x 24"W	HRVF5024P	\$254	\$1,524
2	Abound Panel Frame 50"H x 60"W	HRVF5060P	\$319	\$638
6	Abound Top Cap Trim 24"W	HRVTC24	\$36	\$216
2	Abound Top Cap Trim 60"W	HRVTC60	\$80	\$160
8	Worksurface Bracket Kit	HWSB2	\$46	\$368
12	Abound Segment Bar 24"W	HRVFSB24	\$21	\$252
4	Abound Segment Bar 60"W	HRVFSB60	\$25	\$100
4	Abound Open Shelf 60"	HRVSH60	\$357	\$1,428
12	Abound Fabric Tile 15"H x 24"W	HRVT1524T	\$64	\$768
4	Abound Fabric Tile 15"H x 60"W	HRVT1560T	\$93	\$372
12	Abound Fabric Tile 30"H x 24"W	HRVT3024T	\$88	\$1,056
4	Abound Fabric Tile 30"H x 60"W	HRVT3060T	\$135	\$540
4	Systems Rectangular Worksurface Edgeband 24"D x 60"W	HWR2460P	\$477	\$1,908
TOTAL:			\$11,204	

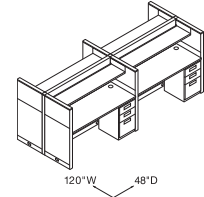

TOUCH-DOWN STATION
120"W x 48"D

QTY	DESCRIPTION	MODEL	LIST PRICE	PRICE EXTENSION
2	External Stiffener 72"W	HLZLZ55C72	\$110	\$220
2	Abound Panel Frame 35"H x 30"W	HRFF3530P	\$238	\$476
4	Abound Fabric Tile 30"H x 30"W	HRVT3030T	\$92	\$368
4	Abound Panel Frame 35"H x 36"W	HRFF3536P	\$244	\$976
8	Abound Fabric Tile 30"H x 36"W	HRVT3036T	\$99	\$792
2	Abound Panel Frame 35"H x 42"W	HRFF3542P	\$253	\$506
4	Abound Fabric Tile 30"H x 42"W	HRVT3042T	\$112	\$448
2	Abound Finished End Painted 35"	HRVC35PF	\$76	\$152
2	Abound L Connector Painted 35"	HRVC35PL	\$135	\$270
4	Frameless Frosted Glass 15"H x 72"W	HRVT1572F	\$937	\$3,748
2	Contain [®] 35 LB Credenza Counterweight Kit	HSCACW35	\$196	\$392
2	Contain [®] Credenza Cushion (Fabric Grade 2) 36"W x 18"D	HSCAUC1836	\$316	\$632
2	Worksurface O-Leg 6½"H x 30"W	HSCAWS6530	\$225	\$450
1	Contain [®] Footed Metal Credenza with Laminate Front, Left 22" x 72" x 18"	HSCSF227218LBFOLA	\$2,287	\$2,287
1	Contain [®] Footed Metal Credenza with Laminate Front, Right 22" x 72" x 18"	HSCSF227218RBFOLA	\$2,287	\$2,287
2	Systems Rectangular Worksurface Edgeband 30"D x 72"W	HWR3072P	\$593	\$1,186
2	Worksurface Bracket Kit	HWSB2	\$46	\$92
TOTAL:			\$15,282	

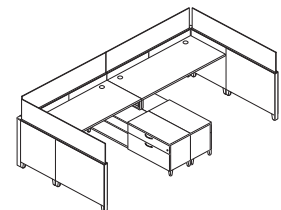

U-SHAPE TEAMING STATION
144"W x 72"D

ABOUND® Open Base Typicals



Icon Legend on page 19

WORKSTATIONS

QTY	DESCRIPTION	MODEL	LIST PRICE	PRICE EXTENSION
1	Abound Panel Frame 50"H x 24"W	HRFF5024P	\$254	\$254
2	Abound Fabric Tile 30"H x 24"W	HRVT3024T	\$88	\$176
1	Abound 15" High Clear Glass Tile 12"H x 24"W	HRVT1524G	\$462	\$462
2	Abound 24"W Segment Bar	HRVFSB24	\$21	\$42
1	Abound Panel Frame 50"H x 48"W	HRFF5048P	\$290	\$290
2	Abound Fabric Tile 30"H x 48"W	HRVT3048T	\$120	\$240
1	Abound 15" High Clear Glass Tile 15"H x 48"W	HRVT1548G	\$594	\$594
2	Abound 48"W Segment Bar	HRVFSB48	\$24	\$48
3	Abound Panel Frame 65"H x 24"W	HRFF6524P	\$276	\$828
6	Abound Fabric Tile 60"H x 24"W	HRVT6024T	\$131	\$786
1	Abound Panel Frame 65"H x 48"W	HRFF6548P	\$315	\$315
2	Abound Fabric Tile 60"H x 48"W	HRVT6048T	\$212	\$424
1	Overhead Cabinet with Sliding Door 48"W x 14 1/4"D x 14"H	HLSL1448S	\$1,078	\$1,078
1	Mobile Ped 20" x 15 1/8" x 21 1/2"	HLSL2016MP2	\$794	\$794
1	Ped Cushion 20" x 15 1/8" x 1"	HLSL2016PH2	\$333	\$333
1	Stack-on Storage Panel Mounted Bracket	HLSLPMB	\$131	\$131
1	Personal Storage Tower (RH) 24"D x 24"W x 65"H	HLSLW446RP	\$2,609	\$2,609
1	Abound Variable Height Finished End Painted 15"	HRVC15PFV	\$62	\$62
1	Abound Finished End Painted 50"	HRVC50PF	\$92	\$92
1	Abound L Connector Painted 50"	HRVC50PL	\$152	\$152
1	Abound Finished End Painted 65"	HRVC65PF	\$97	\$97
2	Abound L Connector Painted 65"	HRVC65PL	\$160	\$320
1	Bracket to Attach Towers to Worksurfaces	HSTB2W1	\$76	\$76
2	Systems Rectangular Worksurface Edgeband 24"D x 48"W	HWR2448P	\$404	\$808
2	Worksurface Bracket Kit	HWSB2	\$46	\$92
1	Abound Top Cap Trim 24"W	HRVTC24	\$36	\$36
1	Abound Top Cap Trim 48"W	HRVTC48	\$65	\$65
1	Abound Top Cap Trim 72"W	HRVTC72	\$100	\$100
1	Flat Bracket 24"D	HHN831124	\$64	\$64
TOTAL:			\$11,368	

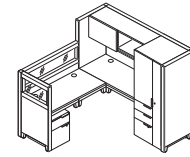

**L-SHAPE WORKSTATION
WITH STORAGE TOWER**

72"W x 72"D

ABOUT® FRAMES OVERVIEW

PANEL FRAME

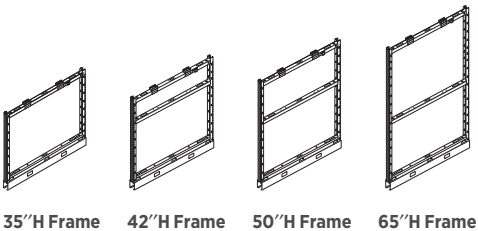

35" H Frame 42" H Frame 50" H Frame 65" H Frame

OPEN BASE PANEL FRAME

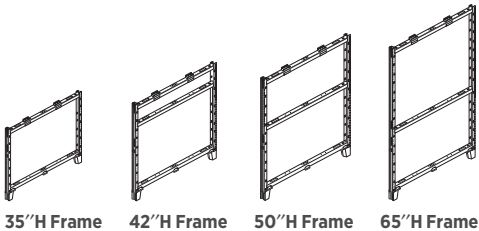

35" H Frame 42" H Frame 50" H Frame 65" H Frame



STACKING FRAMES

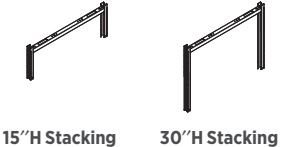

15" H Stacking 30" H Stacking

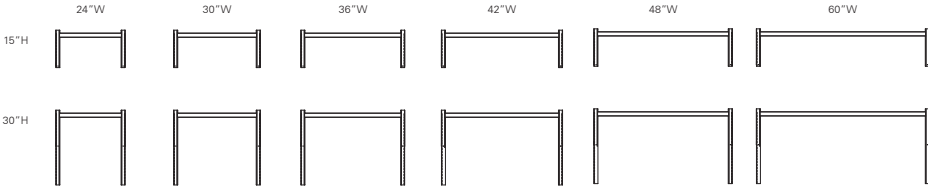

Reminder: Panel frame top caps must be ordered separately. Please refer to page 410. Do not specify top caps when putting frameless glass on top of the panel frame or when using a countertop worksurface.

ABOUND® FRAMES OVERVIEW

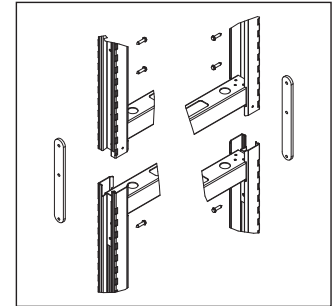
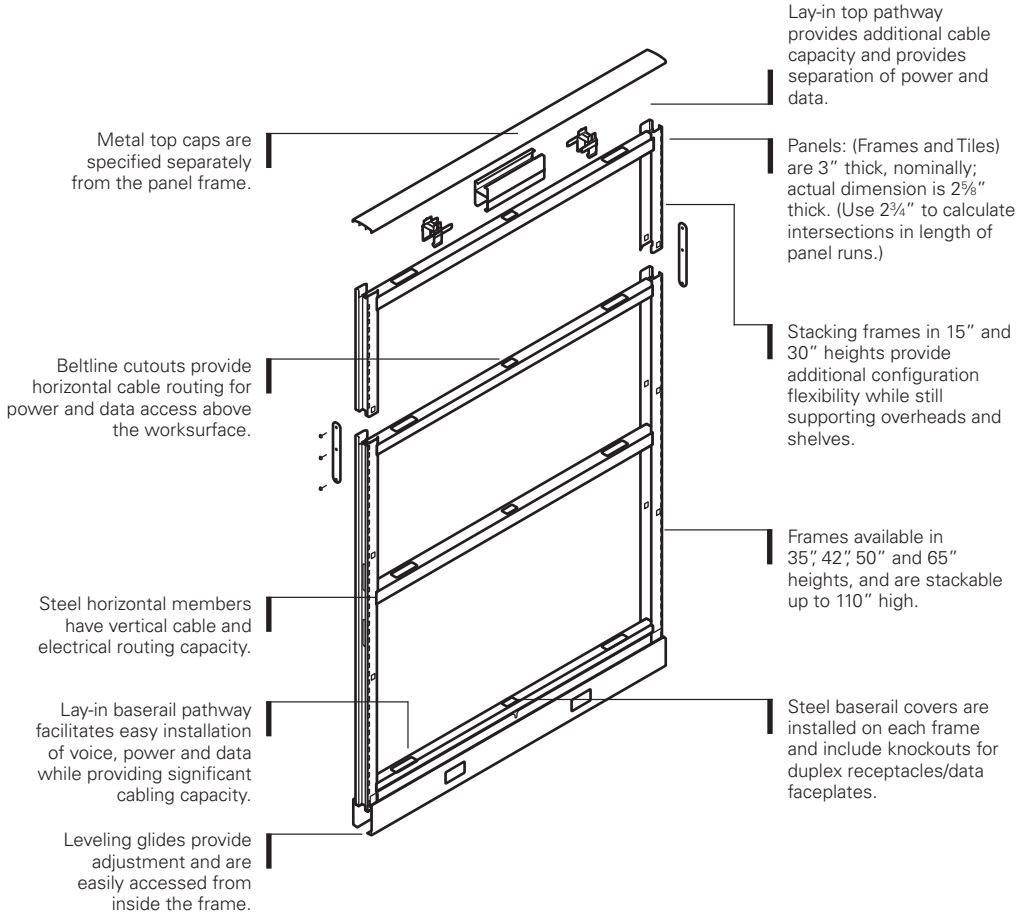

Stacking connection provides a solid metal-to-metal connection, allowing the stacking frame to accept hang-on components, per configuration guidelines.

Construction and Features

Specifications—formed, steel vertical members, with tubular steel horizontal members are welded into a sturdy, structural panel frame. Panel frames are shipped with base pathway covers installed.

Tiles, Panel Top Caps, and Segment Bars are ordered separately.

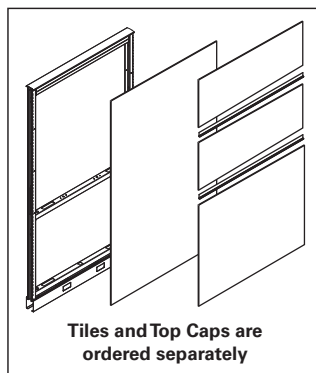

Additional design and specification information available at hon.com.

ABOUND[®] FRAMES OVERVIEW

FRAME DIMENSIONS (ACTUAL)

Depth: 2 $\frac{5}{8}$ " (use 2 $\frac{3}{4}$ " to calculate intersections in length of panel run)

Widths: 24", 30", 36", 42", 48", 60"

Heights*: Painted trim: 34 $\frac{1}{2}$ ", 42", 49 $\frac{1}{2}$ ", 64 $\frac{1}{2}$ "

Stacking Frames: 15"H, 30"H

*with levelers fully retracted

Stacking frames can be added to the top of any 35"H, 50"H or 65"H frame. Adding stacking frames to 42"H frames is not recommended due to inconsistencies in segmentation. 15"H and 30"H stacking frames can be used to add up to 45" of additional height to a standard frame. Do not combine differing frame widths in a single stack.

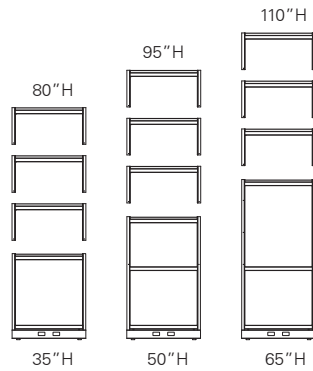

NOTE: When stacking on 42 $\frac{1}{2}$ "H frames, panel slots will be off by $\frac{1}{2}$ " compared to any other height panel. When stacking on 42 $\frac{1}{2}$ "H frames, hanging accessories will be $\frac{1}{2}$ " off in height compared to accessories hanging on panels at any height other than 42 $\frac{1}{2}$ "H.

BUILDING HORIZONTALLY WITH ABOUND FRAMES

Important planning guidelines: For adequate stability, one of two methods of stabilization must be adhered to:

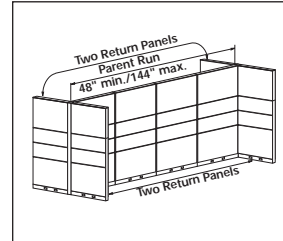

Method 1—Opposing returns:

A parent run must be a minimum of 48" and a maximum of 144" between return panels. The parent run must have a minimum of two return panels running in opposing directions on each end of run.

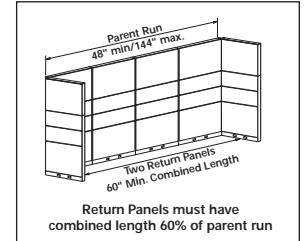

Method 2—Single-sided

Spine Length:	90 degree connector	120 degree connector
48"-108"	72" total	84" total
110"-132"	84" total	96" total
134"-144"	96" total	108" total

ABOUND® FRAMES OVERVIEW

INTERSECTING CONNECTIONS

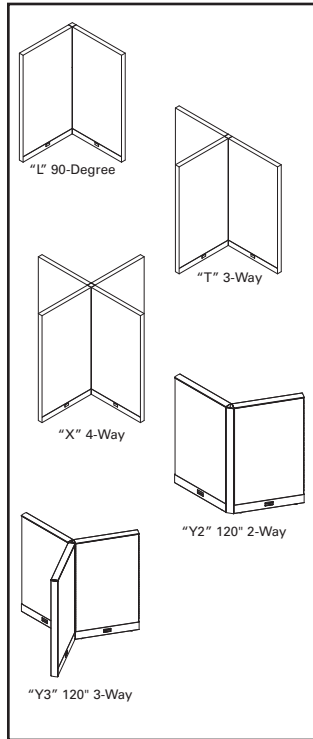

“L”, “T”, “X”, “Y2” and “Y3” connector kits are used when connecting frames at intersecting runs. For “L”, “T” and “X” connector kits, add $2\frac{3}{4}$ ” to the total length of the panel run for each intersection, whether located in the middle or at the end of the run.

Wall starter kits provide a means to affix a panel run to a permanent building wall. Kit adds $1\frac{1}{2}$ ” to length of panel run.

Segment bars — horizontal cross members required between tile segments. Must be specified on each side of frame. One Segment Bar is needed for each reveal between tiles.

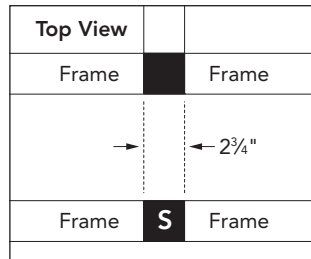
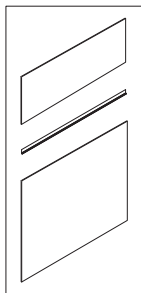

Extended straight connector kit “S” can be used to keep continuous runs dimensionally consistent with opposing panel runs which incorporate “T” or “X” intersections. (Add $2\frac{3}{4}$ ” to the length of the run for every extended straight connector used.)

IN-LINE CONNECTIONS

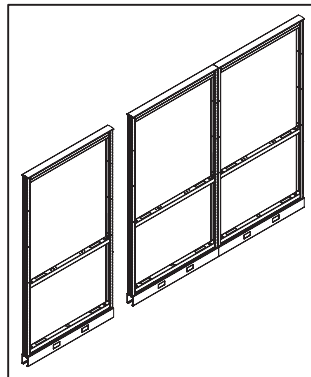

Direct connections between same height frames in a continuous run are accomplished with provided hardware. There is no incremental increase in dimension along the run.

END OF RUN

Finished end trim must be specified for the unconnected sides of panel frames. The Abound end trim adds $\frac{3}{8}$ ” to the length of the panel run. When adding a stacking frame, order finished end trim in the height that matches the stacking frame height. Move the end cap from the standard frame end trim to the stacking frame end trim.

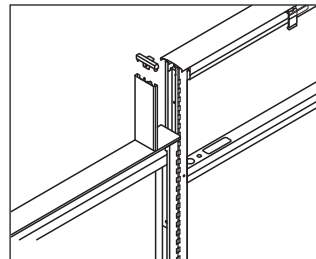

IN-LINE VARIABLE HEIGHT TRIM

In-line connections between different height panels require trim to cover the exposed frame of the taller panel. The bottom of the trim is contoured to match the profile of the frame top cap.

Multiple-height connections are accomplished by combining standard height panel connectors (35”H, 42”H, 50”H and 65”H) with shorter connectors (7”H, 15”H, 22”H and 30”H). Start from the bottom-up — select the standard connector that corresponds to the height and connection type of the tallest panel, then use the shorter connectors for variable height and connector top cap trim. (See examples.)

Example 1
1 ea. 50”H T-Connector
1 ea. 15”H S-Connector

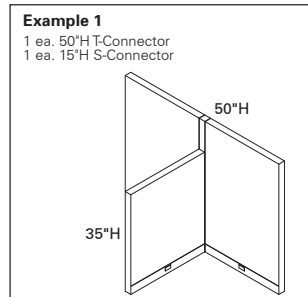

In variable height “T” connections — as shown above — you would use the connectors as indicated.

Example 2
Connectors required:
1-35”H “X”
1-7”H “T”
1-7”H “L”
1-15”H “FT”

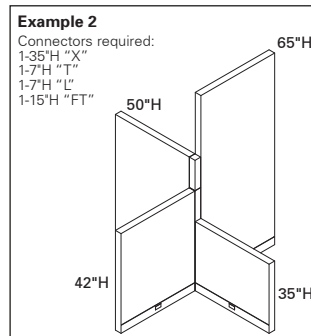

Example 3

Connectors required:
1-50”H “L”
1-15”H Variable Height Trim over Connector

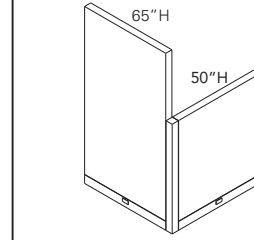

Example above represents Abound variable height “L” for 65” to 50” connection over connector.

VARIABLE HEIGHT CONNECTION TRIM

L, X and T connections between different height panels require trim to cover the exposed frame of the taller panel. The bottom of the trim is flat to match the profile of the Universal Connector top cap. Models are designated as “Variable Height Finished End over Connector Trim”. For variable height connections in a Y configuration, contact the HON Product Solutions group.

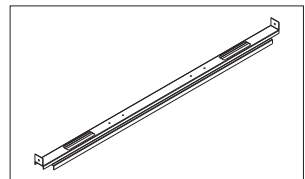

OPTIONAL STIFFENER SUPPORT

Stiffener supports can be used to provide additional rigidity to a panel when fabric tiles are on both sides of the frame. May also be used for routing power/data at non-standard heights.

ABOUND[®] CONNECTOR OVERVIEW

CONNECTOR KITS — ABOUND

- “L” 90° Connector Kit
- “T” 3-way Connector Kit
- “X” 4-way Connector Kit
- “S” “S” Extended Straight Connector Kit
- “Y2” 2-way 120° Connector Kit
- “Y3” 3-way 120° Connector Kit
- “W” Wall Starter Kit
- “F” End Trim Kit
- “V” Variable Height Finished End
- “FT” Variable Height Finished End over Connector

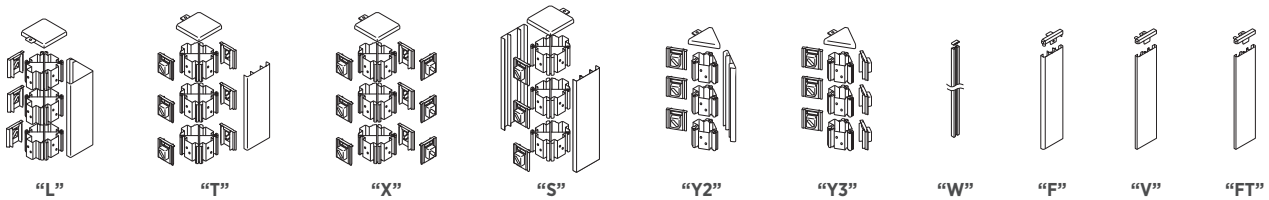

- Abound Connector Kits include universal connector block(s), bracket clips and painted metal trim.
- The universal connector block can be used for an L, T, X, or Extended Straight connections, simplifying staging and installation at the project site as well as future reconfigurations.
- Bracket clips are attached to the connector blocks as needed based upon connection type.
- While the connectors themselves are universal, Abound connector kits must be specified by connection type (X, L, T, S, 120 degree) in order to receive the correct type of trim.

ABOUND[®] TILE OVERVIEW

About tiles come in a variety of styles.

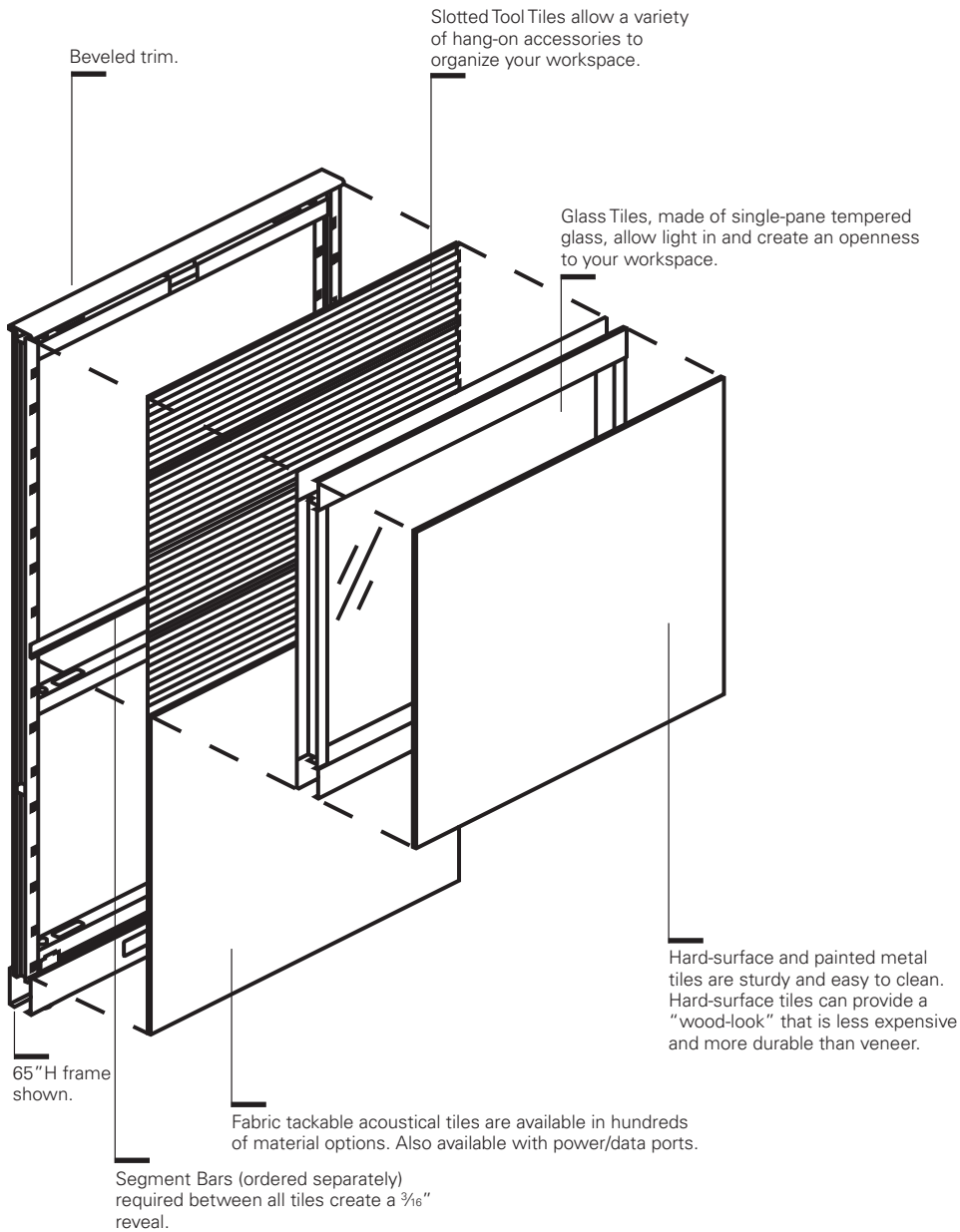

*Aesthetics of opposing tile surface and/or frame interior should be considered when selecting light-colored sheer materials.

ABOUT® SPECIFYING/DESIGN GUIDE

Tile Heights

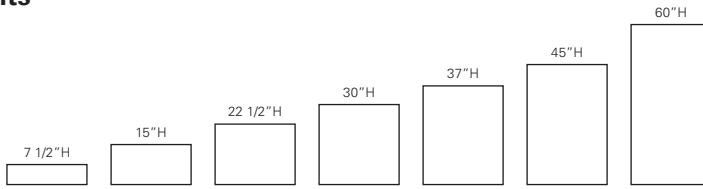

Monolithic tiles are 5" shorter than frame heights to account for top trim and base raceway.

Typical Tile Height Configurations

Segment bars are required between any two tiles — order separately based on tile configuration on each side of frame. Note: Most CAD specification programs will calculate quantity of segment bars required.

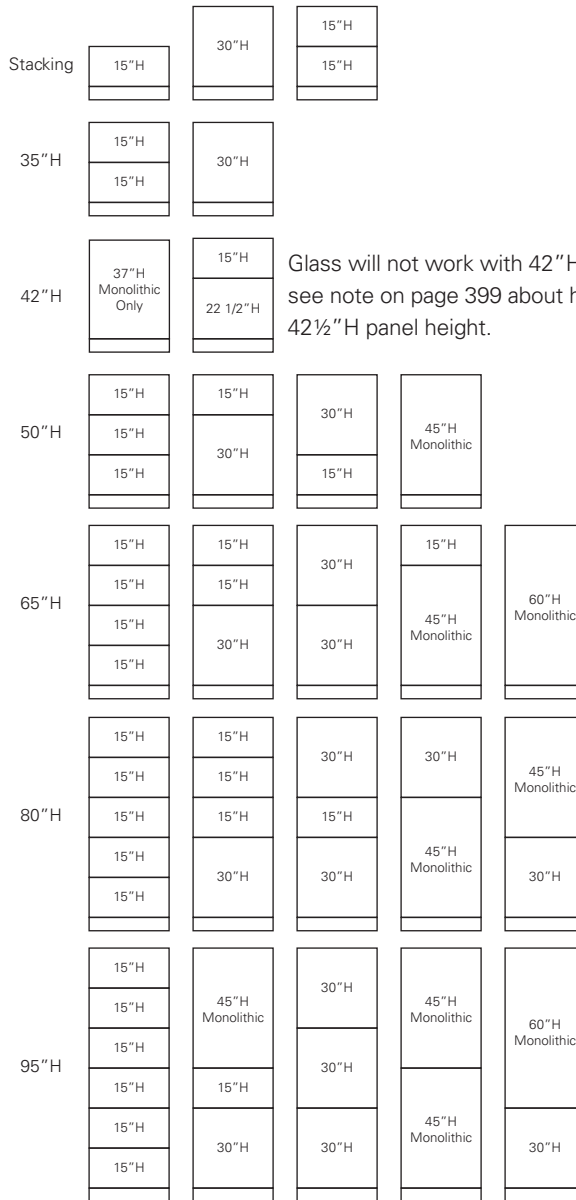

Glass will not work with 42"H frames. Please see note on page 399 about hanging on 42 1/2"H panel height.

*Additional tile combinations to those shown above are possible; heights above 65" require stacking frames - maximum height is 110."

To calculate the total height of tiles(s) required, deduct 5" (height of base/top trim) from the total nominal panel height.

EXAMPLE: 65"H Frame takes 2 30"H tiles. $65-5 = 2 \times 30$ or $45 + 15$

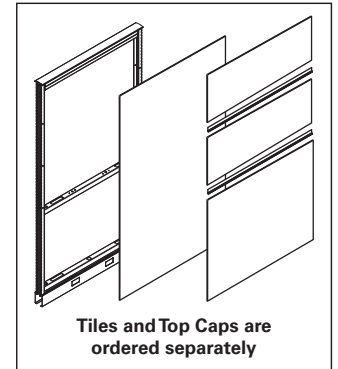

Tiles can be ordered in the size that matches the frame height plus the stacker height.

EXAMPLE: If you are using a 35"H frame plus a 30"H stacker, you can order 2 - 30"H tiles or 1 - 60"H tile.

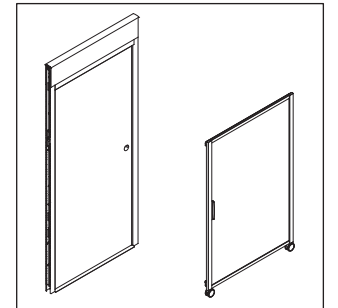

Door panels include frame, 42"W door, hinges and attaching hardware. Two 7 1/2"H fabric tiles for the top of the door frame are required and ordered separately (HRVDO742T).

Sliding doors are available in 50", 65", and 80"H models and can mount to 30", 36", 42", and 48"W panels. The doors provide a 36"W opening and are 42"W, nominally. The doors ship non-handed. A Mounting Bracket Kit must be ordered for each door corresponding to the mounting panel's width (30", 36", 42", or 48"W).

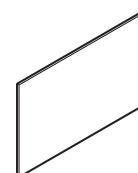

Hard-surface Tiles include tile and Custom Bracket Kit.

ABOUND[®] SPECIFYING/DESIGN GUIDE

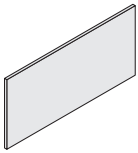

Fabric Tackable Acoustical Tile

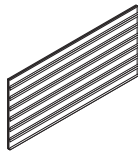

Slotted Tool Tile

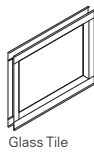

Glass Tile

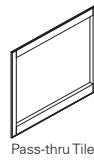

Pass-thru Tile

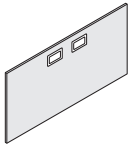

Fabric Tackable Acoustical Ported Tile

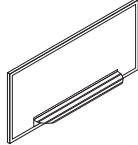

Tile
* tray ordered separately

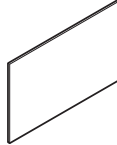

Hard-surface Tiles

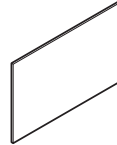

Painted Metal Tile

Tiles — Tackable Acoustical, Tackable Acoustical/Ported

	24"W	30"W	36"W	42"W	48"W	60"W
7 1/2"H						
15"H						
22 1/2"H						
30"H						
37"H						
45"H						
60"H						

Glass Tile Kits, Painted Metal Tiles

	24"W	30"W	36"W	42"W	48"W	60"W
15"H						
30"H						

Pass-thru Tiles

	24"W	30"W	36"W	42"W	48"W	60"W
30"H						

Slotted Tool Tile

	24"W	30"W	36"W	42"W	48"W	60"W
15"H						

Hard-surface Tiles

	24"W	30"W	36"W	42"W	48"W	60"W
15"H						
30"H						
37"H						

TILES

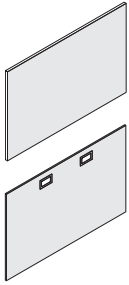

Tackable Acoustical Fabric Tiles

- Tiles do not include segment bars — order separately.

Port Tiles

- Receptacle openings with blank covers (1 in 24"W tiles; 2 in wider tiles). Located 30" above bottom of base raceway and 10½" from the edge of the frame.
- Tiles do not include segment bars — order separately.
- 30"H ported tiles on 35"H frame will need additional stiffener support.
- Ported tiles should only be used to accommodate beltline height. If a port is needed at an alternate height, please submit a special request.
- Tiles cannot be flipped to move data ports.
- Duplex brackets must be specified for ported tiles.

Painted Metal

- Tiles do not include segment bars — order separately.
- Painted steel construction.
- 15"H and 30"H tiles are non-dedicated and can be used in any tile position.
- Tiles can accept magnets.

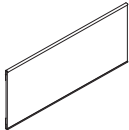

Tool Tiles

- Tiles do not include segment bars — order separately.
- Sturdy aluminum extrusion with steel support construction.
- Powder coated for durable finish.
- Work tools available.
- Use in place of standard 15"H tiles.
- Cannot be used in the bottom location of a panel frame or on wall track.
- Each tool tile has a suggested weight capacity of 80 lbs. of paper management accessories.

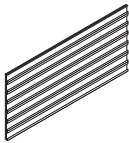

Pass-Thru Tiles

- Pass-thru opening is 22½"H.
- Used as 30"H tile.
- Must order quantity of one 7½"H tile if finishing one side and quantity of two 7½"H tiles if finishing both sides.
- No segment bar needed above tile.
- Built into trim pieces.

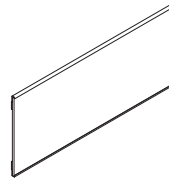
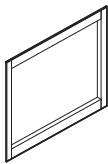

Hard Surface

- High Pressure Laminate — available in standard laminate colors.
- Tiles do not ship with segment bars — order separately.
- Tiles come completely assembled and attach with custom tile bracket kit. Specify paint color.
- 15"H, 30"H, and 37"H tiles are non-dedicated and can be used in any tile position.
- Vertical grain on all tile sizes.

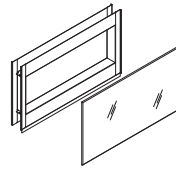

Glass Tiles

- Clear and frosted glass.
- Clear glass is writeable with dry erase marker — frosted glass is not.
- Tempered safety glass encased within a frame.
- Single-pane construction, glass is flush on one side.
- Glass opening is 4" less than nominal heights and widths.
- Cannot be used in top tile position of a 42½"H panel frame or any frame with integrated power pole.
- Cannot be used at the bottom or beltline location of panel frame.
- 30"H glass tiles can only be placed in top position of 65"H frames or only in 30"H stacking frame. Segment bar needs to be ordered.

Marker Board Tiles

- White marker board tile; painted steel surface.
- Accepts magnetic accessories.
- 15"W magnetically attachable tray is natural aluminum color — order separately.
- 15"H and 30"H tiles are non-dedicated and can be used in any tile position.

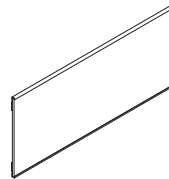

Gallery Panels

- 1½" thick laminate panels used as wing or end of run panels only.
- Available in 42½"H and 50"H options.
- Options available to include frameless glass.
- Gallery Panel connectors purchased separately.

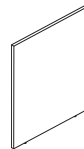

Custom Material Bracket Kit

- Do not ship with segment bars — order separately.
- Used with Customer's Own Material — thickness is ¼".
- Contact HON for insert dimensions.

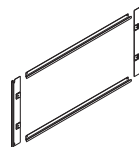

ABOUND[®] GALLERY PANELS OVERVIEW

GALLERY PANELS

Abound[®] Gallery Panels are an affordable, sleek way to incorporate laminate wing and end of run panels where power is not needed. The simplistic design provides a great new way to add woodgrains or solid laminate finishes to your workstation allowing for greater customization and value engineering.

BASIC CHARACTERISTICS

- Available in L-, T-, and Mid-configurations.
- Made of 1½" board with high-pressure laminate.
- Use 1½" thickness for space planning.
- Can be specified with matching or contrasting edge colors.
- Available in woodgrain and solid laminates.
- Woodgrain laminates can be specified with vertical grain on panels from 24" to 60"W.
- Horizontal grain available on all panel sizes.
- Gallery Panels offer 2½" leveling capacity.
- Overall heights line up with adjacent panel.
- Available with and without integrated glass options (specified separately).
- Gallery Panels for use with glass have separate model numbers.
- All configurations are non-handed and secured using hidden fasteners.
- Cannot be connected to another Gallery Panel.
- Gallery Panel widths are true to size.
- Please adhere to all standard systems specification guidelines.

GALLERY PANEL OFFERING

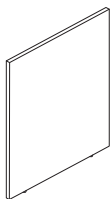

Wing End of Run

42"H, 50"H x 27", 33", 39", 45", 51", 63"W

Wing Middle of Run

42"H, 50"H x 24", 30", 36", 42", 48", 60"W

Spanning End of Run

42"H, 50"H x 51", 63", 75"W

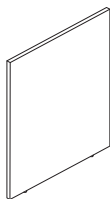

Wing End of Run for Glass

42"H, 50"H x 27", 33", 39", 45", 51", 63"W

Wing Middle with Glass

42"H, 50"H x 24", 30", 36", 42", 48", 60"W

Spanning End of Run with Glass

42"H, 50"H x 51", 63", 75"W

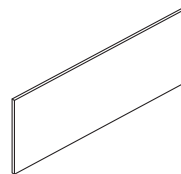

Wing End of Run Glass

7½"H x 27", 33", 39", 45", 51", 63"W

Wing Middle Glass

7½"H x 24", 30", 36", 42", 48", 60"W

Spanning End of Run Glass

7½"H x 51", 63", 75"W

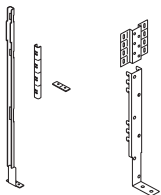

Gallery Panel Connectors

Spanning End of Run, L Connectors, and Wing Middle Brackets



Gallery Connector

("Block and Trim" Kit)
For 35"-65"H Panels

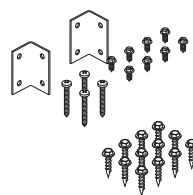

Gallery to Metal/Laminate Kits

ABOUT® GALLERY PANELS OVERVIEW

T-CONFIGURATION

- Provides privacy to one or both ends of the About® system in a dual-sided application.
- All T-configurations connect using HRVCE connector kit.
- When the system panel is higher than the Gallery Panel, a variable height system's trim must be specified to finish off the exposed frame.
- T-configuration can be used for off-modular planning. The HRVCE connector kit location must be field measured.
- Accommodate for 2 $\frac{5}{8}$ " frame thickness when planning with About® panel system.

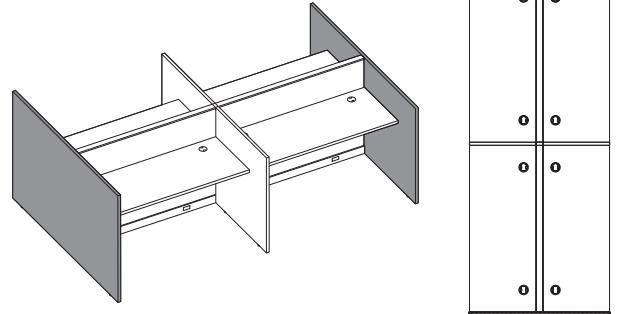

L-CONFIGURATION

- Provides privacy to one or both ends of the system in a single-sided application.
- L-configuration caps over the system panel.
- Due to the thickness of the About® panel L-configuration overhangs by approximately $\frac{3}{16}$ " on both sides.
- Accommodate for 2 $\frac{5}{8}$ " frame thickness planning with About® panel system.
- All L-configuration Gallery Panels require the connector kit HRVCE to attach to the parent run.
- When the system panel is higher than the Gallery Panel, the variable height system's trim must be specified to finish off exposed frame.

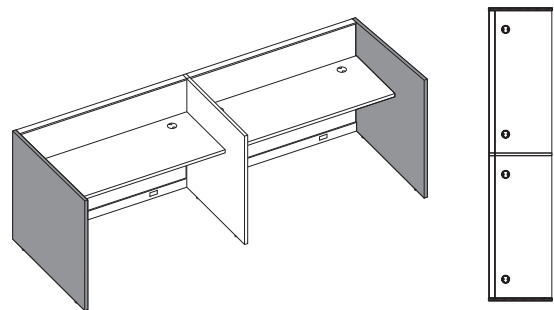

MID-CONFIGURATION (SINGLE-SIDED OR DUAL-SIDED)

- Mid-configuration panel does not overlap parent system panel.
- When specifying mid-configuration panels, one Gallery Panel "block and trim" kit (HRVCXXGP) is required to space the system panels out 1 $\frac{1}{8}$ ". Kits include: Connector blocks, vertical trim, and a top cap.
- "Block and trim" models must match the height of the parent run.
- Specify one mid-connector kit (HRVCM) per Gallery Panel to attach to parent run. Gallery Panel and mid-connector kit attach over "block and trim" kit. Dual-sided application requires two connector kit models.
- When using a mid-configuration Gallery Panel, both panel frames in the spine must be of equal height.
- Mid-configuration Gallery Panel may not exceed the height of the parent run.
- Trims can be painted to match the system panel trims.



ABOUND[®] GALLERY PANELS OVERVIEW

STORAGE AND WORKSURFACE CONNECTORS

- Use HRVGLSK to connect to laminate storage or HRVGMSK for metal storage.
- To connect to worksurfaces use HSTB2W1 bracket when used in perpendicular to parent run or use standard systems cantilever brackets when used in parallel to parent run in panel systems.

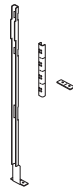

HRVCE

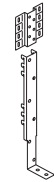

HRVCM



HRVCXXGP

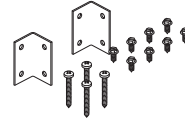

HRVGLSK



HRVGMSK

PANEL SYSTEMS

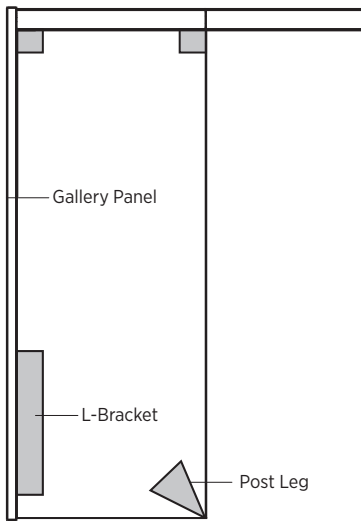

Perpendicular panel system with L-bracket (HSTB2W1) and post leg.

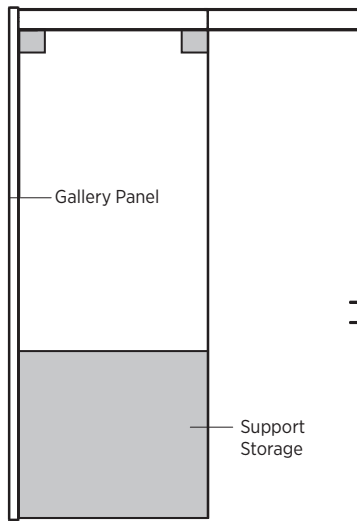

Perpendicular panel system with storage support.

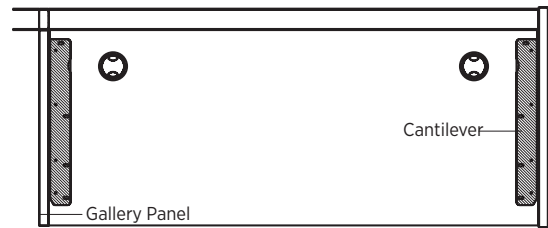

Panel system with cantilever support.

About String-in Capacity

Openings in frame sides permit electrical data and communication cables to be run between frames in Abound. Using tackable acoustical tiles, the beltline pathway accommodates up to 62 cables (.25" dia) or 46 cables with electrical components installed.

DO NOT run electrical equipment or extension cords through cable openings in frame sides. Use beltline or base-mounted electrical system for all electrical supply.

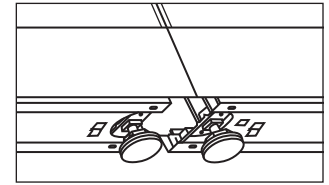
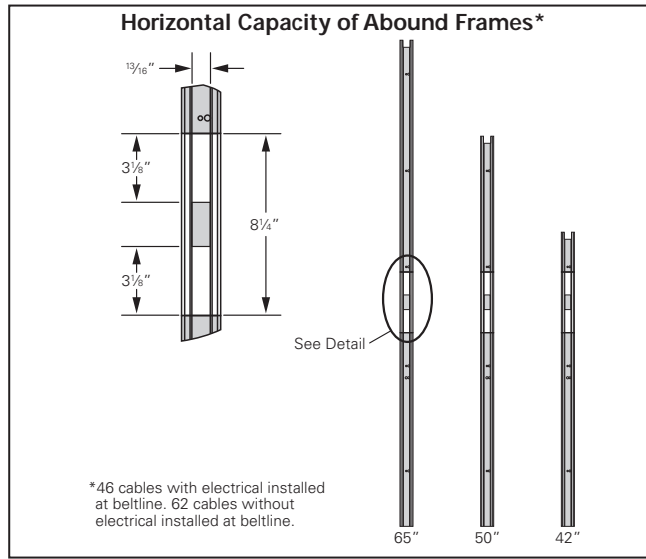

Cables can enter/exit panel through underside of base pathway at juncture between frames. Openings are sized as follows (in sq. in.):

Straight connection	6.0
"S" Extended Straight Connection	10.0
"L" 90° Connection	8.9
"T" Connection	15.9
"X" Connection	17.9
"Y" Connection	—

When leveling glides are fully retracted, panel-to-floor clearance is 7/16". This may affect the volume of cabling that can be fed into the frame from the bottom of the pathway.

Vertical Capacity

Vertical Capacity Through Panel Frames

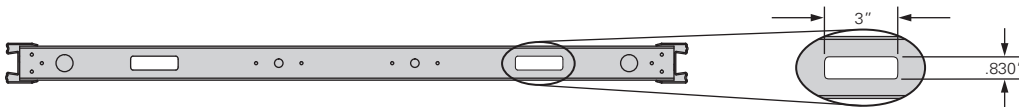

- A 60% fill ratio is achievable; however, when electrical components are installed in the beltline area, cabling capacity through the beltline area will be limited to approximately 45% fill ratio.

	Panel Width	Qty of .25" Cables at 45% Fill Ratio	Qty of .25" Cables at 60% Fill Ratio	Total Space (sq. in.)
Abound	24" - 60"W	48	64	5.26

ABOUND® Panel Frames

GSA SIN 33721



Icon Legend on page 19

WORKSTATIONS

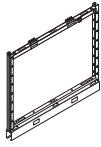

DESCRIPTION

35" H Panel Frame

35" H x 24" W
35" H x 30" W
35" H x 36" W
35" H x 42" W
35" H x 48" W
35" H x 60" W

MODEL

HRVF3524P
HRVF3530P
HRVF3536P
HRVF3542P
HRVF3548P
HRVF3560P

SHIP WEIGHT

8.0
11.0
13.0
16.0
18.0
23.0

CUBE

1.7
2.1
2.4
2.8
3.2
4.0

LIST PRICE BY PAINT GRADE

P1 P2

\$232 \$268
\$238 \$274
\$244 \$280
\$253 \$289
\$267 \$303
\$296 \$332

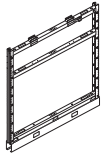

42" H Panel Frame

42" H x 24" W
42" H x 30" W
42" H x 36" W
42" H x 42" W
42" H x 48" W
42" H x 60" W

HRVF4224P
HRVF4230P
HRVF4236P
HRVF4242P
HRVF4248P
HRVF4260P

11.0
14.0
17.0
19.0
22.0
28.0

2.0
2.4
2.9
3.4
3.8
4.7

\$238 \$274
\$248 \$284
\$253 \$289
\$268 \$304
\$281 \$317
\$313 \$349

ⓘ When stacking on 42 1/2" H frames, panel slots will be off by 1/2" compared to any other height panel.

ⓘ When stacking on 42 1/2" H frames, hanging accessories will be 1/2" off in height compared to accessories hanging on panels at any height other than 42 1/2" H.

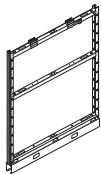

50" H Panel Frame

50" H x 24" W
50" H x 30" W
50" H x 36" W
50" H x 42" W
50" H x 48" W
50" H x 60" W

HRVF5024P
HRVF5030P
HRVF5036P
HRVF5042P
HRVF5048P
HRVF5060P

14.0
17.0
20.0
24.0
27.0
34.0

2.3
2.9
3.4
4.0
4.5
5.6

\$254 \$290
\$267 \$303
\$267 \$303
\$284 \$320
\$290 \$326
\$319 \$355

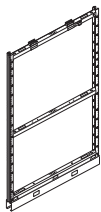

65" H Panel Frame

65" H x 24" W
65" H x 30" W
65" H x 36" W
65" H x 42" W
65" H x 48" W
65" H x 60" W

HRVF6524P
HRVF6530P
HRVF6536P
HRVF6542P
HRVF6548P
HRVF6560P

17.0
22.0
25.0
30.0
35.0
43.0

3.0
3.7
4.4
5.1
5.8
7.2

\$276 \$312
\$281 \$317
\$286 \$322
\$297 \$333
\$315 \$351
\$343 \$379



Panel Top Cap

24" W
30" W
36" W
42" W
48" W
54" W
60" W
66" W
72" W
78" W
84" W
90" W
96" W

HRVTC24
HRVTC30
HRVTC36
HRVTC42
HRVTC48
HRVTC54
HRVTC60
HRVTC66
HRVTC72
HRVTC78
HRVTC84
HRVTC90
HRVTC96

1.6
1.8
2.0
2.2
3.4
3.7
3.9
4.0
5.3
6.5
6.7
7.0
7.2

0.3
0.3
0.3
0.3
0.4
0.5
0.6
0.6
0.8
0.8
0.9
0.9
0.9

\$36 \$56
\$44 \$64
\$56 \$76
\$59 \$79
\$65 \$85
\$80 \$100
\$80 \$100
\$96 \$116
\$100 \$120
\$103 \$123
\$114 \$134
\$120 \$140
\$126 \$146

NOTES: Top caps can span more than one panel in an in-line connection.

ⓘ Top cap models are to be used on Abound® frames only.

NOTES:

- Includes frame, baserail covers, attaching hardware and bottom segment bar.
- Frames, top caps and tiles are ordered and shipped separately.
- Frames are 2 5/8" thick with a 5" H baserail.
- Frames are standard with two adjustable leveling glides which can be adjusted from the bottom of the glide or from the interior of frame.
- Two wire and data management openings standard per raceway, 24" panel has one opening.
- Lay-in wire management available in base. Horizontal cable routing available at beltline.
- Lay-in top pathway provides additional data cabling capacity.
- For worksurfaces that can be used with both Abound® and Accelerate® systems, see pages 568-578.
- Panel stability will be increased by tying panels to worksurfaces or storage.

HOW TO SPECIFY

Select Model Number

Select Trim Color

See page 391

HRVF3524P T4



ABOUND® Open Base Panel Frames

	DESCRIPTION	MODEL	SHIP WEIGHT	CUBE	LIST PRICE BY PAINT GRADE	
					P1	P2
	35" H Open Base Panel Frame					
	35" H x 24" W	HRFF3524P	8	1.7	\$232	\$268
	35" H x 30" W	HRFF3530P	11	2.1	\$238	\$274
	35" H x 36" W	HRFF3536P	13	2.4	\$244	\$280
	35" H x 42" W	HRFF3542P	16	2.8	\$253	\$289
	35" H x 48" W	HRFF3548P	18	3.2	\$267	\$303
	35" H x 60" W	HRFF3560P	23	4.0	\$296	\$332
	42" H Open Base Panel Frame					
	42" H x 24" W	HRFF4224P	11	2.0	\$238	\$274
	42" H x 30" W	HRFF4230P	14	2.4	\$248	\$284
	42" H x 36" W	HRFF4236P	17	2.9	\$253	\$289
	42" H x 42" W	HRFF4242P	19	3.4	\$268	\$304
	42" H x 48" W	HRFF4248P	22	3.8	\$281	\$317
	42" H x 60" W	HRFF4260P	28	4.7	\$313	\$349
	<p>ⓘ When stacking on 42½" H frames, panel slots will be off by ½" compared to any other height panel.</p> <p>ⓘ When stacking on 42½" H frames, hanging accessories will be ½" off in height compared to accessories hanging on panels at any height other than 42½" H.</p>					
	50" H Open Base Panel Frame					
	50" H x 24" W	HRFF5024P	14	2.3	\$254	\$290
	50" H x 30" W	HRFF5030P	17	2.9	\$267	\$303
	50" H x 36" W	HRFF5036P	20	3.4	\$267	\$303
	50" H x 42" W	HRFF5042P	24	4.0	\$284	\$320
	50" H x 48" W	HRFF5048P	27	4.5	\$290	\$326
	50" H x 60" W	HRFF5060P	34	5.6	\$319	\$355
	65" H Open Base Panel Frame					
	65" H x 24" W	HRFF6524P	17	3.0	\$276	\$312
	65" H x 30" W	HRFF6530P	22	3.7	\$281	\$317
	65" H x 36" W	HRFF6536P	25	4.4	\$286	\$322
	65" H x 42" W	HRFF6542P	30	5.1	\$297	\$333
	65" H x 48" W	HRFF6548P	35	5.8	\$315	\$351
	65" H x 60" W	HRFF6560P	43	7.2	\$343	\$379
	Raceway to Open Base Conversion Kit	HRVFFOOT	4	0.1	\$166	\$186

NOTES:

- Includes frame, attaching hardware and bottom segment bar.
- Tiles and top caps are ordered and shipped separately.
- Frames are 2⅝" thick with a 5" H open base.
- Frames are standard with two adjustable leveling glides which can be adjusted from the bottom of the glide.
- Horizontal cable routing available at beltline.
- Lay-in top pathway provides additional data cabling capacity.
- See page 410 for top cap options.
- For worksurfaces that can be used with Abound® and Accelerate® systems, see pages 568-578.
- Panel stability will be increased by tying panels to worksurfaces or storage.

HOW TO SPECIFY

<p>Select Model Number</p> <p>HRFF3524P</p>	<p>Select Trim Color</p> <p>See page 391</p> <p>T4</p>
---	--

ABOUND[®] Stacking Panel Frames

GSA SIN 33721



Icon Legend on page 19

WORKSTATIONS



DESCRIPTION

15"H Stacking Panel Frame

15"H x 24"W
15"H x 30"W
15"H x 36"W
15"H x 42"W
15"H x 48"W
15"H x 60"W

MODEL

HRVF1524
HRVF1530
HRVF1536
HRVF1542
HRVF1548
HRVF1560

SHIP WEIGHT

8
10
12
14
16
20

CUBE

0.8
0.9
1.1
1.3
1.5
1.8

LIST PRICE

\$216
\$226
\$232
\$242
\$244
\$251

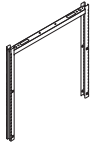

30"H Stacking Panel Frame

30"H x 24"W
30"H x 30"W
30"H x 36"W
30"H x 42"W
30"H x 48"W
30"H x 60"W

HRVF3024
HRVF3030
HRVF3036
HRVF3042
HRVF3048
HRVF3060

10
12
14
16
18
22

1.4
1.8
2.1
2.4
2.8
3.4

\$228
\$242
\$249
\$258
\$262
\$279



Full Segment Bars

24"W
30"W
36"W
42"W
48"W
60"W

HRVFSB24
HRVFSB30
HRVFSB36
HRVFSB42
HRVFSB48
HRVFSB60

2
2
3
3
3
4

0.4
0.4
0.5
0.5
0.6
0.7

\$21
\$21
\$22
\$23
\$24
\$25

❗ Must order one segment bar per panel reveal, per panel side.

NOTES:

- Frames, top caps and tiles are ordered and shipped separately.
- Includes attachment hardware.
- Stacking frames can be added to the top of any 35"H, 50" or 65"H frame.
- No paint selection necessary on stacking frames.
- Overhead storage units can be suspended from stacking frames. See pages 534-535.
- Segment Bars do not need to be specified for monolithic tiles, when only a single tile is attached to the frame.

- ❗ When stacking on 42½"H frames, panel slots will be off by ½" compared to any other height panel.
- ❗ When stacking on 42½"H frames, hanging accessories will be ½" off in height compared to accessories hanging on panels at any height other than 42½"H.
- ❗ Not designed to combine differing frame widths in a single stack.
- ❗ Stacking frames not designed to be used as a base frame.
- ❗ Segment bars available in Black only.
- ❗ Segment Bars are formed, steel cross members and are required between tiles and on each side of the frame.

HOW TO SPECIFY

Select
Model Number

HRVF1524



Icon Legend on page 19

ABOUND® Stiffener Supports



DESCRIPTION

Stiffener Support

- 24"W
- 30"W
- 36"W
- 42"W
- 48"W
- 60"W

MODEL

- HRVSS24**
- HRVSS30**
- HRVSS36**
- HRVSS42**
- HRVSS48**
- HRVSS60**

SHIP WEIGHT

- 1
- 1
- 4
- 4
- 4
- 4

CUBE

- 0.4
- 0.4
- 0.5
- 0.5
- 0.5
- 0.7

LIST PRICE

- \$55**
- \$57**
- \$61**
- \$76**
- \$85**
- \$93**

! Black only. No need to specify paint.

NOTES:

- Tile stiffener supports can be used to increase the stiffness of a panel and can also be used to mount power/data anywhere vertically on an Abound frame. Can only be used when there are fabric tiles on both sides of the frame.
- Self-drilling screws included.

! Black only. No need to specify paint.

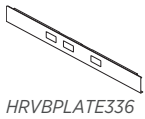

HRVBPLATE336

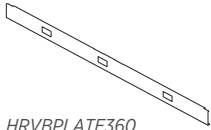

HRVBPLATE360

DESCRIPTION

Abound® Base Pathway Cover w/Additional Knockout

- 36"W
- 42"W
- 48"W
- 60"W

MODEL

- HRVBPLATE336**
- HRVBPLATE342**
- HRVBPLATE348**
- HRVBPLATE360**

SHIP WEIGHT

- 7
- 8
- 9
- 11

CUBE

- 0.4
- 0.4
- 0.4
- 0.5

LIST PRICE BY PAINT GRADE

P1

- \$72**
- \$74**
- \$77**
- \$88**

P2

- \$82**
- \$84**
- \$87**
- \$98**

NOTES: Specify paint, see page 391.

SPECIFYING EXAMPLE: HRVBPLATE336.T4

NOTES:

- ! Specify Pathways to match trim color.
- ! Standard raceways with two knockouts are standard on panels. If additional three knockout kickplate is ordered, the two port version can be saved or discarded.

HOW TO SPECIFY

<p>Select Model Number</p> <p>HRVBPLATE336 . T4</p>	<p>Select Paint Color</p> <p>See page 391</p>
--	--

ABOUND[®] Panel Door

GSA SIN 33721



Icon Legend on page 19

WORKSTATIONS



DESCRIPTION	MODEL	SHIP WEIGHT	CUBE	L1 LIST PRICE BY PAINT GRADE	
				P1	P2
Door Panel — Laminate 42"W x 95"H NOTES: Includes frame, 42"W door, hinges and attaching hardware. Lockset or Knob ordered separately. Best placement of a door is at an L, T, X connector or wall starter connector for rigidity. Use of spanning top caps at an in-line will also help add additional rigidity. ! Two HRVD0742T tiles for above the door must be ordered per each door ordered. See below. ! Top Cap must be ordered separately. See page 410 for top cap specification.	HRVD9542P	155	5.4	\$2228	\$2264



HOW TO SPECIFY

Select Model Number HRVD9542P	Select Trim Color See page 391 T4	Select Door Laminate L1 Woodgrain only See page 391 K2
---	--	--

DESCRIPTION	MODEL	SHIP WEIGHT	CUBE	LIST PRICE BY FABRIC GRADE						
				A	B	C	D	E	F	G
 Fabric Tiles for Door Panel 7½"H x 42"W ! Must be ordered with the Door Panel model above. ! Required for door installation. ! Two tiles must be ordered for installation. Tiles ship 1/pkg.	HRVD0742T	3	1.2	\$83	\$87	\$91	\$101	\$104	\$108	\$112

HOW TO SPECIFY

Select Model Number HRVD0742T	Select Fabric Color See pages 392-393 APN15
---	--

	DESCRIPTION	MODEL	SHIP WEIGHT	CUBE	LIST PRICE
	Lockset (Door Knob) Polished Brass, keyed on one side	HN899900	2.0 Ⓢ	0.1	\$117
	Door Lever Brushed Aluminum, keyed on one side	HN899910	2.0 Ⓢ	0.1	\$324
	Carpet Grippers NOTES: Used with Glide Towers Shipped 12 per package No need to specify finish	HICG12	0.5 Ⓢ	0.1	\$20



Icon Legend on page 19

ABOUND[®] Sliding Door

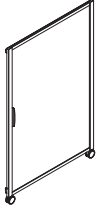

DESCRIPTION

Abound Sliding Door

50”H x 42”W
65”H x 42”W
80”H x 42”W

MODEL

HH15042SD
HH16542SD
HH18042SD

SHIP WEIGHT CUBE

28 5.5
38 7.1
46 8.6

LIST PRICE BY PAINT GRADE

P1 P2

\$2038 \$2074
\$2324 \$2360
\$2843 \$2879

- ! Door is only available in Frosted Translucent Acrylic. Specify paint for frame.
- ! Can only install Sliding Door at the end of a run, not at a corner.

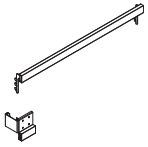

Mounting Kit for Abound Sliding Door

For 30”W Panel
For 36”W Panel
For 42”W Panel
For 48”W Panel

HHKDMK30
HHKDMK36
HHKDMK42
HHKDMK48

4 0.4
5 0.5
6 0.5
7 0.5

\$175 \$187
\$183 \$195
\$189 \$201
\$199 \$211

NOTES: Specify paint.

NOTES:

- The Sliding Doors are available in 50”, 65”, and 80”H models and can mount to 30”, 36”, 42”, and 48”W panels.
- All doors are 42” wide, provide a 36”W opening, and are non-handed.
- ! A Mounting Bracket Kit must be ordered for each door corresponding to the mounting panels width (30”, 36”, 42”, or 48”W).

HOW TO SPECIFY

Select Model Number

HH15042SD

Select Paint Color

See page 391

T1

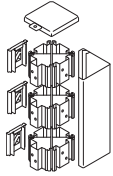

DESCRIPTION

"L" 90° Painted Connector

	MODEL	SHIP WEIGHT	CUBE	LIST PRICE BY PAINT GRADE	
				P1	P2
7"H Frame	HRVC7PL	1 Ⓞ	0.1	\$93	\$110
15"H Frame	HRVC15PL	2 Ⓞ	0.1	\$105	\$122
22"H Frame	HRVC22PL	2 Ⓞ	0.2	\$118	\$135
30"H Frame	HRVC30PL	3 Ⓞ	0.3	\$135	\$152
35"H Frame	HRVC35PL	3 Ⓞ	0.3	\$135	\$152
42"H Frame	HRVC42PL	4 Ⓞ	0.4	\$147	\$164
50"H Frame	HRVC50PL	5 Ⓞ	0.5	\$152	\$169
65"H Frame	HRVC65PL	6 Ⓞ	0.6	\$160	\$177
80"H Frame	HRVC80PL	6 Ⓞ	0.8	\$166	\$183

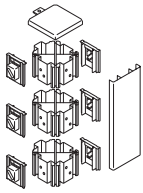

"T" 3-Way Painted Connector

7"H Frame	HRVC7PT	1 Ⓞ	0.1	\$93	\$110
15"H Frame	HRVC15PT	2 Ⓞ	0.1	\$105	\$122
22"H Frame	HRVC22PT	2 Ⓞ	0.2	\$118	\$135
30"H Frame	HRVC30PT	3 Ⓞ	0.3	\$135	\$152
35"H Frame	HRVC35PT	3 Ⓞ	0.3	\$135	\$152
42"H Frame	HRVC42PT	4 Ⓞ	0.4	\$147	\$164
50"H Frame	HRVC50PT	5 Ⓞ	0.5	\$152	\$169
65"H Frame	HRVC65PT	6 Ⓞ	0.6	\$160	\$177
80"H Frame	HRVC80PT	6 Ⓞ	0.8	\$166	\$183

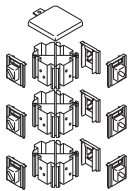

"X" 4-Way Painted Connector

7"H Frame	HRVC7PX	1 Ⓞ	0.1	\$74	\$84
15"H Frame	HRVC15PX	2 Ⓞ	0.1	\$85	\$95
22"H Frame	HRVC22PX	2 Ⓞ	0.2	\$94	\$104
30"H Frame	HRVC30PX	3 Ⓞ	0.3	\$105	\$115
35"H Frame	HRVC35PX	3 Ⓞ	0.3	\$105	\$115
42"H Frame	HRVC42PX	4 Ⓞ	0.4	\$142	\$152
50"H Frame	HRVC50PX	6 Ⓞ	0.5	\$147	\$157
65"H Frame	HRVC65PX	7 Ⓞ	0.6	\$152	\$162
80"H Frame	HRVC80PX	6 Ⓞ	0.8	\$160	\$170

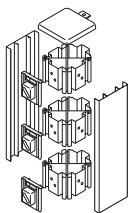

"S" Extended Straight Painted Connector

7"H Frame	HRVC7PS	1 Ⓞ	0.1	\$115	\$132
15"H Frame	HRVC15PS	2 Ⓞ	0.1	\$126	\$143
22"H Frame	HRVC22PS	2 Ⓞ	0.2	\$136	\$153
30"H Frame	HRVC30PS	3 Ⓞ	0.3	\$147	\$164
35"H Frame	HRVC35PS	3 Ⓞ	0.3	\$147	\$164
42"H Frame	HRVC42PS	4 Ⓞ	0.4	\$168	\$185
50"H Frame	HRVC50PS	6 Ⓞ	0.5	\$176	\$193
65"H Frame	HRVC65PS	7 Ⓞ	0.6	\$187	\$204
80"H Frame	HRVC80PS	7 Ⓞ	0.8	\$201	\$218

NOTES:

- All connectors include a light-gap strip.
- Abound connectors utilize a universal connector block designed to make one connection to the panel.
- Bracket clips come standard.
- 7"H connectors include one connector block; 15"H, 22"H, 30"H include two connector blocks; 50"H includes three connector blocks and 65"H includes four connector blocks.
- Connectors ship complete with trim.
- Outer trim snaps easily into place.
- Extended Straight Connectors are used to keep a frame run dimensionally consistent with opposing frame runs. Add 2¾" to the length of the run with each Extended Straight Connector used.

! Trim with Abound connectors can only be attached to connectors, not on panels.

HOW TO SPECIFY







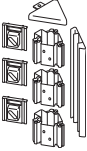

Select Model Number

Select Paint Color

See page 391

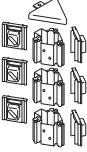
HRVC35PL . T4



	DESCRIPTION	MODEL	SHIP WEIGHT	CUBE	LIST PRICE BY PAINT GRADE	
					P1	P2
	"Y" 120° Degree, Two-Sided, Painted Connector					
	35"H Frame	HRVC35PY2	3 	0.3	\$135	\$152
	42"H Frame	HRVC42PY2	4 	0.4	\$147	\$164
	50"H Frame	HRVC50PY2	5 	0.5	\$160	\$177
	65"H Frame	HRVC65PY2	6 	0.6	\$176	\$193
	"Y" 120° Degree, Three-Sided, Painted Connector					
	35"H Frame	HRVC35PY3	3 	0.3	\$118	\$135
	42"H Frame	HRVC42PY3	4 	0.4	\$135	\$152
	50"H Frame	HRVC50PY3	5 	0.5	\$147	\$164
	65"H Frame	HRVC65PY3	6 	0.6	\$160	\$177

NOTES:

- 35"H-42"H connectors include two universal connector blocks, 50"H includes three brackets and 65"H includes four brackets.
- Use Y Connectors for 120° applications.
- Abound connectors utilize a universal connector block designed to make one connection to the panel.
- Connectors ship complete with trim.
- Bracket clips come standard.
- Outer trim snaps easily into place.

HOW TO SPECIFY

<p>Select Model Number</p> <p>HRVC35PY2</p>	<p>Select Paint Color</p> <p>See page 391</p> <p>T3</p>
--	--



Variable Height Finished End and Wall Starter Kits



DESCRIPTION	MODEL	SHIP WEIGHT	CUBE	LIST PRICE BY PAINT GRADE	
				P1	P2
Finished End					
15"H Finished End	HRVC15PF	1 Ⓞ	0.1	\$62	\$79
30"H Finished End	HRVC30PF	2 Ⓞ	0.3	\$76	\$93
35"H Finished End	HRVC35PF	2 Ⓞ	0.3	\$76	\$93
42"H Finished End	HRVC42PF	2 Ⓞ	0.4	\$85	\$102
50"H Finished End	HRVC50PF	3 Ⓞ	0.5	\$92	\$109
65"H Finished End	HRVC65PF	4 Ⓞ	0.6	\$97	\$114
80"H Finished End	HRVC80PF	4 Ⓞ	0.8	\$102	\$119



Variable Height Painted Finished End					
7" Variable Height Finished End	HRVC7PFV	1 Ⓞ	0.1	\$62	\$72
15" Variable Height Finished End	HRVC15PFV	1 Ⓞ	0.1	\$62	\$72
22" Variable Height Finished End	HRVC22PFV	2 Ⓞ	0.2	\$76	\$86
30" Variable Height Finished End	HRVC30PFV	2 Ⓞ	0.3	\$76	\$86



Variable Height Painted Finished End Over Connector					
7" Variable Height Finished End Over Connector	HRVC7PFT	1 Ⓞ	0.1	\$62	\$72
15" Variable Height Finished End Over Connector	HRVC15PFT	1 Ⓞ	0.1	\$62	\$72
22" Variable Height Finished End Over Connector	HRVC22PFT	2 Ⓞ	0.2	\$76	\$86
30" Variable Height Finished End Over Connector	HRVC30PFT	2 Ⓞ	0.3	\$76	\$86



Frameless Glass Variable Height Trim					
7½"H	HRVC7FFV	1	0.1	\$56	\$65
15"H	HRVC15FFV	1	0.1	\$83	\$92
Specify paint only.					
ⓘ Model only used with Frameless Glass on page 427.					
SPECIFYING EXAMPLE: HRVC7FFV.T1					



Wall Starter Kit					
65"H	HRVC65PW	5 Ⓞ	0.6	\$176	\$193

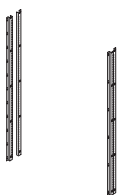

Permanent Wall Hanger Kit					
2½"W x 7/8"D x 66"H	HRVC35PCE	6 Ⓞ	0.7	\$218	\$238
4¼"W x 7/8"D x 66"H	HRVC35PCM	3 Ⓞ	0.7	\$114	\$124
ⓘ Anchor devices are not supplied with this model. Refer to Abound® Installation instructions for appropriate hardware. Attachment to masonry walls is not recommended.					

Specify paint

NOTES:

- Snaps easily onto end of frame.
- 35"H end trim includes top cap and vertical trim.
- 15"H and 30"H Finished End Trims do not include a top cap. These are only used for stacking frames which utilize the top trim and cap from the base frame to which they are attached.
- 42", 50" and 65"H finished end trim includes painted top transition piece, vertical trim and carpet grippers for extra stability.

- End trim is full-length to floor; no baserail cap is necessary.
- Finished Ends include top cap trim. Adds 1½" to panel run.
- Wall Starter Kit allows panel to start from a wall. Specify trim color.
- Wall Starter adds 1½" to length of panel run.
- Anchor devices are not supplied with the wall starter kits.

ⓘ Variable height trim and finished ends can only be attached to panels, not attached to connectors.

HOW TO SPECIFY

Select Model Number	Select Paint Color
HRVC7PFT	T3
See page 391	



WALL HANGER BARS AND OFF-MODULE BRACKET

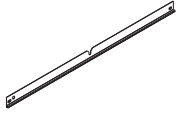

DESCRIPTION	MODEL	SHIP WEIGHT	CUBE	LIST PRICE BY PAINT GRADE	
				P1	P2
Wall Hanger Segment Bars					
24"W	HRVFSBW24	2	0.4	\$32	N/A
30"W	HRVFSBW30	2	0.4	\$32	N/A
36"W	HRVFSBW36	3	0.5	\$34	N/A
42"W	HRVFSBW42	3	0.5	\$38	N/A
48"W	HRVFSBW48	3	0.6	\$42	N/A
60"W	HRVFSBW60	4	0.7	\$46	N/A

Includes two tile bars. Top bar may only be used in the top uppermost position on Wall Track. Bottom bar can be used in the bottom position at any point on the wall hangers. When segmenting tiles on Wall Hangers, standard Segment Bars (page 412) must be ordered for placement between each tile reveal or at the top position of a single tile that is not in the uppermost position.

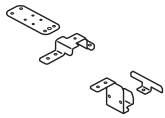

Off-Module Bracket Kit	HRVOMOD	2	0.1	\$85	\$95
-------------------------------	----------------	---	-----	-------------	-------------

- Includes top and bottom attachment brackets and top trim finished end.
- Installation requires defacing of the top tile.

Cannot be mounted in locations where the bottom bracket covers electrical cutouts in the base pathway on parent run panels.

HOW TO SPECIFY

Select Model Number

HRVFSBW24

ABOUND[®] Tackable Acoustical Tiles

GSA SIN 33721



Icon Legend on page 19

WORKSTATIONS

DESCRIPTION	MODEL	SHIP WEIGHT	CUBE	LIST PRICE BY FABRIC GRADE							
				AA	A	B	C	D	E	F	G
7½" H Tackable Acoustical Fabric Tiles											
7½" H x 24" W	HRVT0724T	2	0.4	\$62	\$66	\$69	\$71	\$77	\$82	\$87	\$90
7½" H x 30" W	HRVT0730T	2	0.5	\$73	\$77	\$80	\$84	\$90	\$97	\$100	\$103
7½" H x 36" W	HRVT0736T	2	0.6	\$78	\$82	\$85	\$89	\$95	\$102	\$105	\$108
7½" H x 42" W	HRVT0742T	2	0.7	\$86	\$91	\$95	\$99	\$109	\$112	\$116	\$120
7½" H x 48" W	HRVT0748T	2	0.8	\$92	\$97	\$101	\$105	\$115	\$118	\$122	\$126
7½" H x 60" W	HRVT0760T	3	1.0	\$110	\$130	\$134	\$139	\$151	\$155	\$158	\$161
15" H Tackable Acoustical Fabric Tiles											
15" H x 24" W	HRVT1524T	2	0.8	\$64	\$73	\$81	\$89	\$105	\$123	\$139	\$147
15" H x 30" W	HRVT1530T	2	0.9	\$65	\$76	\$86	\$96	\$118	\$139	\$150	\$160
15" H x 36" W	HRVT1536T	2	1.1	\$72	\$83	\$93	\$103	\$125	\$146	\$157	\$167
15" H x 42" W	HRVT1542T	2	1.3	\$74	\$87	\$99	\$114	\$147	\$158	\$168	\$179
15" H x 48" W	HRVT1548T	2	1.5	\$80	\$93	\$105	\$120	\$153	\$164	\$174	\$185
15" H x 60" W	HRVT1560T	3	1.8	\$93	\$106	\$118	\$133	\$166	\$177	\$187	\$198
22½" H Tackable Acoustical Tiles											
22½" H x 24" W	HRVT2224T	2	1.1	\$74	\$84	\$93	\$103	\$122	\$144	\$158	\$167
22½" H x 30" W	HRVT2230T	2	1.4	\$77	\$89	\$100	\$113	\$136	\$164	\$191	\$201
22½" H x 36" W	HRVT2236T	2	1.6	\$84	\$99	\$112	\$123	\$160	\$190	\$201	\$211
22½" H x 42" W	HRVT2242T	2	1.9	\$91	\$106	\$119	\$133	\$176	\$200	\$211	\$222
22½" H x 48" W	HRVT2248T	2	2.2	\$97	\$112	\$125	\$139	\$182	\$206	\$217	\$228
22½" H x 60" W	HRVT2260T	3	2.6	\$112	\$127	\$140	\$154	\$197	\$221	\$232	\$243
30" H Tackable Acoustical Tiles											
30" H x 24" W	HRVT3024T	2	1.4	\$88	\$99	\$109	\$120	\$142	\$169	\$180	\$190
30" H x 30" W	HRVT3030T	2	1.8	\$92	\$105	\$117	\$132	\$157	\$191	\$235	\$245
30" H x 36" W	HRVT3036T	2	2.1	\$99	\$117	\$133	\$145	\$198	\$236	\$247	\$257
30" H x 42" W	HRVT3042T	3	2.4	\$112	\$128	\$143	\$155	\$209	\$246	\$258	\$268
30" H x 48" W	HRVT3048T	3	2.8	\$120	\$136	\$151	\$163	\$217	\$254	\$266	\$276
30" H x 60" W	HRVT3060T	4	3.4	\$135	\$151	\$166	\$178	\$232	\$269	\$281	\$291
37" H Tackable Acoustical Tiles											
37" H x 24" W	HRVT3724T	2	2.0	\$101	\$117	\$132	\$150	\$203	\$235	\$247	\$257
37" H x 30" W	HRVT3730T	3	2.4	\$115	\$131	\$146	\$164	\$217	\$249	\$261	\$271
37" H x 36" W	HRVT3736T	4	2.9	\$131	\$150	\$169	\$190	\$254	\$301	\$312	\$323
37" H x 42" W	HRVT3742T	4	3.4	\$147	\$168	\$188	\$212	\$293	\$341	\$351	\$362
37" H x 48" W	HRVT3748T	5	3.8	\$154	\$175	\$197	\$220	\$303	\$352	\$364	\$375
37" H x 60" W	HRVT3760T	6	4.6	\$176	\$202	\$228	\$259	\$341	\$401	\$412	\$424

Segment bars ordered separately. See page 412.

NOTES:

- Tiles attach directly onto the panels. No additional hardware is needed.
- Tiles are non-dedicated.
- For monolithic applications, subtract 5" from the frame height to determine monolithic tile height.
- Fabric tiles have a Class A fire rating.
- Tiles do not include segment bars, must be ordered separately. See page 412. Not needed on monolithic tiles.
- One segment bar required per panel reveal, per panel side.

HOW TO SPECIFY

Select Model Number	Select Fabric Color
	See pages 392-393
HRVT1524T	APN11



Icon Legend on page 19

ABOUND® Tackable Acoustical Tiles



DESCRIPTION	MODEL	SHIP WEIGHT	CUBE	LIST PRICE BY FABRIC GRADE							
				AA	A	B	C	D	E	F	G
45" H Tackable Acoustical Tiles											
45" H x 24" W	HRVT4524T	2	2.3	\$111	\$130	\$150	\$171	\$237	\$285	\$296	\$308
45" H x 30" W	HRVT4530T	3	2.9	\$127	\$148	\$168	\$193	\$276	\$324	\$336	\$348
45" H x 36" W	HRVT4536T	5	3.4	\$151	\$172	\$194	\$217	\$300	\$349	\$361	\$372
45" H x 42" W	HRVT4542T	5	4.0	\$176	\$197	\$217	\$242	\$324	\$373	\$385	\$397
45" H x 48" W	HRVT4548T	6	4.5	\$199	\$220	\$248	\$265	\$348	\$397	\$409	\$420
45" H x 60" W	HRVT4560T	7	5.6	\$217	\$243	\$270	\$301	\$382	\$442	\$454	\$466



60" H Tackable Acoustical Tiles											
60" H x 24" W	HRVT6024T	3	3.0	\$131	\$162	\$195	\$229	\$317	\$371	\$384	\$425
60" H x 30" W	HRVT6030T	4	3.7	\$149	\$185	\$223	\$260	\$352	\$417	\$430	\$494
60" H x 36" W	HRVT6036T	6	4.4	\$174	\$210	\$248	\$283	\$376	\$441	\$455	\$519
60" H x 42" W	HRVT6042T	6	5.1	\$187	\$228	\$272	\$308	\$417	\$482	\$495	\$586
60" H x 48" W	HRVT6048T	7	5.8	\$212	\$253	\$297	\$333	\$442	\$551	\$565	\$655
60" H x 60" W	HRVT6060T	9	7.2	\$226	\$273	\$321	\$357	\$505	\$587	\$599	\$690

Segment bars ordered separately. See page 412.

NOTES:

- Tiles are non-dedicated.
- Tiles attach directly onto the panels. No additional hardware is needed.
- For monolithic applications, subtract 5" from the frame height to determine monolithic tile height.
- Fabric tiles have a Class A fire rating.
- Tiles do not include segment bars, must be ordered separately. See page 412. Not needed on monolithic tiles.
- One segment bar required per panel reveal, per panel side.

HOW TO SPECIFY

<p>Select Model Number</p> <div style="border: 1px solid black; display: flex; gap: 2px; padding: 2px;"> HRVT4524T </div>	<p>Select Fabric Color</p> <p>See pages 392-393</p> <div style="border: 1px solid black; display: flex; gap: 2px; padding: 2px;"> APN11 </div>
--	---

ABOUND[®] Power/Data Fabric Tiles

GSA SIN 33721



Icon Legend on page 19

WORKSTATIONS



DESCRIPTION	MODEL	SHIP WEIGHT	CUBE	LIST PRICE BY FABRIC GRADE								
				AA	A	B	C	D	E	F	G	
15" H Power/Data Fabric Tiles												
15" H x 24" W	HRVT1524E	2	0.8	\$129	\$138	\$146	\$154	\$170	\$188	\$204	\$212	
15" H x 30" W	HRVT1530E	2	0.9	\$130	\$141	\$151	\$161	\$183	\$204	\$215	\$225	
15" H x 36" W	HRVT1536E	2	1.1	\$137	\$148	\$158	\$168	\$190	\$211	\$222	\$232	
15" H x 42" W	HRVT1542E	2	1.3	\$140	\$153	\$165	\$180	\$213	\$224	\$234	\$245	
15" H x 48" W	HRVT1548E	2	1.5	\$145	\$158	\$170	\$185	\$218	\$229	\$239	\$250	
15" H x 60" W	HRVT1560E	3	1.8	\$156	\$169	\$181	\$196	\$229	\$240	\$250	\$261	

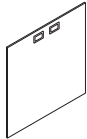

30" H Power/Data Fabric Tiles											
30" H x 24" W	HRVT3024E	2	1.4	\$151	\$162	\$172	\$183	\$205	\$232	\$243	\$253
30" H x 30" W	HRVT3030E	2	1.8	\$155	\$168	\$180	\$195	\$220	\$254	\$298	\$308
30" H x 36" W	HRVT3036E	2	2.1	\$164	\$182	\$198	\$210	\$263	\$301	\$312	\$322
30" H x 42" W	HRVT3042E	3	2.4	\$180	\$196	\$211	\$223	\$277	\$314	\$326	\$336
30" H x 48" W	HRVT3048E	3	2.8	\$185	\$201	\$216	\$228	\$282	\$319	\$331	\$341
30" H x 60" W	HRVT3060E	4	3.4	\$199	\$215	\$230	\$242	\$296	\$333	\$345	\$355

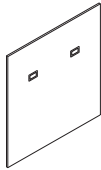

37" H Power/Data Fabric Tiles											
37" H x 24" W	HRVT3724E	2	2.0	\$166	\$182	\$197	\$215	\$268	\$300	\$312	\$322
37" H x 30" W	HRVT3730E	3	2.4	\$182	\$198	\$213	\$231	\$284	\$316	\$328	\$338
37" H x 36" W	HRVT3736E	4	2.9	\$192	\$211	\$230	\$251	\$315	\$362	\$373	\$384
37" H x 42" W	HRVT3742E	4	3.4	\$205	\$226	\$246	\$270	\$351	\$399	\$409	\$420
37" H x 48" W	HRVT3748E	5	3.8	\$221	\$242	\$264	\$287	\$370	\$419	\$431	\$442
37" H x 60" W	HRVT3760E	6	4.7	\$244	\$270	\$296	\$327	\$409	\$469	\$480	\$492

Segment bars ordered separately. See page 412.

NOTES:

- Power/Data tiles are tackable and acoustical.
- Tiles attach directly onto the panels. No additional hardware is needed.
- Tiles are non-dedicated.
- 24" W tiles have one port. Other widths have two.
- Power/Data grommet opening is 2 1/8" W x 1 3/8" H. With glides retracted grommets are 30" from the floor and 10 1/2" from the edge of the frame.
- Power/Data ports are factory installed.

Fabric tiles have a Class A fire rating.

Ports on all tile sizes are located above the worksurface. Tiles cannot be flipped to change port location.

Tiles do not include segment bars, must be ordered separately. See page 412. Can be used in any combination.

One segment bar required per panel reveal, per panel side.

Electrical mounting brackets must be ordered separately. See page 564.

HOW TO SPECIFY

<p>Select Model Number</p> <p>HRVT1524E</p>	<p>Select Fabric Color</p> <p>See pages 392-393</p> <p>APN11</p>	<p>Select Electrical Power/Data Grommet Color</p> <p>See page 391</p> <p>T5</p>
---	--	---



ABOUND[®] Power/Data Fabric Tiles

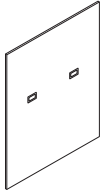

DESCRIPTION	MODEL	SHIP WEIGHT	CUBE	LIST PRICE BY FABRIC GRADE								
				AA	A	B	C	D	E	F	G	
45"H Power/Data Fabric Tiles												
45"H x 24"W	HRVT4524E	2	2.3	\$179	\$198	\$218	\$239	\$305	\$353	\$364	\$376	
45"H x 30"W	HRVT4530E	3	2.9	\$192	\$213	\$233	\$258	\$341	\$389	\$401	\$413	
45"H x 36"W	HRVT4536E	5	3.4	\$219	\$240	\$262	\$285	\$368	\$417	\$429	\$440	
45"H x 42"W	HRVT4542E	5	4.0	\$244	\$265	\$285	\$310	\$392	\$441	\$453	\$465	
45"H x 48"W	HRVT4548E	6	4.5	\$267	\$288	\$316	\$333	\$416	\$465	\$477	\$488	
45"H x 60"W	HRVT4560E	7	5.6	\$286	\$312	\$339	\$370	\$451	\$511	\$523	\$535	

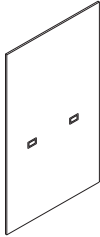

60"H Power/Data Fabric Tiles												
60"H x 24"W	HRVT6024E	3	3.0	\$196	\$227	\$260	\$294	\$382	\$436	\$449	\$490	
60"H x 30"W	HRVT6030E	4	3.7	\$217	\$253	\$291	\$328	\$420	\$485	\$498	\$562	
60"H x 36"W	HRVT6036E	6	4.4	\$240	\$276	\$314	\$349	\$442	\$507	\$521	\$585	
60"H x 42"W	HRVT6042E	6	5.1	\$255	\$296	\$340	\$376	\$485	\$550	\$563	\$654	
60"H x 48"W	HRVT6048E	7	5.8	\$280	\$321	\$365	\$401	\$510	\$619	\$633	\$723	
60"H x 60"W	HRVT6060E	9	7.2	\$294	\$341	\$389	\$425	\$573	\$655	\$667	\$758	

Segment bars ordered separately. See page 412.

NOTES:

- Tiles are non-dedicated.
- Tiles attach directly onto the panels. No additional hardware is needed.
- 24"W tiles have one port. Other widths have two.
- Power/Data grommet opening is 2 1/8"W x 1 3/8"H. With glides retracted grommet are 30" from the floor and 10 1/2" from the edge of the frame.
- Power/Data ports are factory installed.
- Fabric tiles have a Class A fire rating.
- Ports on all tile sizes are located above the worksurface. Tiles cannot be flipped to change port location.
- Tiles do not include segment bars, must be ordered separately. See page 412. Can be used in any combination.
- One segment bar required per panel reveal, per panel side.
- Electrical mounting brackets must be ordered separately. See page 564.

HOW TO SPECIFY

<p>Select Model Number</p> <p>HRVT4524E</p>	<p>Select Fabric Color</p> <p>See pages 392-393</p> <p>APN11</p>	<p>Select Electrical Power/Data Grommet Color</p> <p>See page 391</p> <p>T5</p>
--	---	--

ABOUND[®] Hard-surface Tiles

GSA SIN 33721



Icon Legend on page 19

WORKSTATIONS

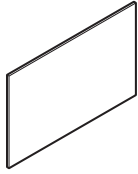

DESCRIPTION

15" Hard-surface Tile and Mounting Kit

- 15"H x 24"W
- 15"H x 30"W
- 15"H x 36"W
- 15"H x 42"W
- 15"H x 48"W
- 15"H x 60"W

MODEL

- HRVT1524HS2**
- HRVT1530HS2**
- HRVT1536HS2**
- HRVT1542HS2**
- HRVT1548HS2**
- HRVT1560HS2**

SHIP WEIGHT

- 11
- 13
- 15
- 17
- 21
- 25

CUBE

- 0.8
- 0.9
- 1.1
- 1.3
- 1.5
- 1.8

LIST PRICE BY LAMINATE GRADE

L1

- \$214**
- \$225**
- \$242**
- \$255**
- \$267**
- \$303**

L2

- \$224**
- \$235**
- \$252**
- \$265**
- \$282**
- \$318**

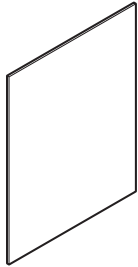

30" Hard-surface Tile and Mounting Kit

- 30"H x 24"W
- 30"H x 30"W
- 30"H x 36"W
- 30"H x 42"W
- 30"H x 48"W
- 30"H x 60"W

- HRVT3024HS2**
- HRVT3030HS2**
- HRVT3036HS2**
- HRVT3042HS2**
- HRVT3048HS2**
- HRVT3060HS2**

- 17
- 19
- 21
- 24
- 28
- 30

- 1.4
- 1.8
- 2.1
- 2.4
- 2.8
- 3.4

- \$261**
- \$282**
- \$313**
- \$342**
- \$361**
- \$396**

- \$276**
- \$297**
- \$328**
- \$357**
- \$381**
- \$416**

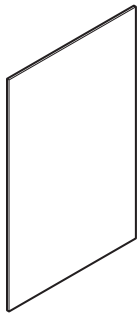

37" Hard-surface Tile and Mounting Kit

- 37"H x 24"W
- 37"H x 30"W
- 37"H x 36"W
- 37"H x 42"W
- 37"H x 48"W
- 37"H x 60"W

- HRVT3724HS2**
- HRVT3730HS2**
- HRVT3736HS2**
- HRVT3742HS2**
- HRVT3748HS2**
- HRVT3760HS2**

- 17
- 17
- 19
- 21
- 24
- 30

- 1.4
- 1.8
- 2.1
- 2.4
- 2.8
- 3.4

- \$319**
- \$352**
- \$386**
- \$425**
- \$459**
- \$520**

- \$339**
- \$372**
- \$406**
- \$445**
- \$484**
- \$545**

NOTES:

- Tiles are made from high-pressure laminate.
- Available in all standard HON laminates.
- On woodgrain laminates, grain direction is vertical.
- Specify paint color.
- 15"H and 30"H tiles are non-dedicated and can be used in any tile position (except on 42"H frames.)

- ❗ All tiles ship with Custom Bracket Kit installed on the tile.
- ❗ One segment bar is required per panel reveal, per panel side.
- ❗ Tiles do not ship with segment bars — must be ordered separately. See page 412. Segment bars are not needed for 42"H monolithic tiles.

HOW TO SPECIFY

<p>Select Model Number</p> <p>HRVT1524HS2</p>	<p>Select Laminate Color</p> <p>See page 391</p> <p>H</p>	<p>Select Paint Color</p> <p>See page 391</p> <p>T1</p>
--	--	--



Icon Legend on page 19

ABOUND® Clear Glass Tiles

WORKSTATIONS

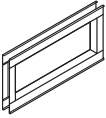
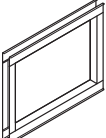
	DESCRIPTION	MODEL	SHIP WEIGHT	CUBE	LIST PRICE BY PAINT GRADE	
					P1	P2
	15”H Clear Glass Tiles					
	15”H x 24”W	HRVT1524G	12 Ⓢ	0.8	\$462	\$481
	15”H x 30”W	HRVT1530G	15 Ⓢ	0.9	\$490	\$509
	15”H x 36”W	HRVT1536G	17 Ⓢ	1.1	\$518	\$537
	15”H x 42”W	HRVT1542G	19 Ⓢ	1.3	\$554	\$574
	15”H x 48”W	HRVT1548G	20 Ⓢ	1.5	\$594	\$614
	15”H x 60”W	HRVT1560G	26 Ⓢ	1.8	\$709	\$729
	30”H Clear Glass Tiles					
	30”H x 24”W	HRVT3024G	15 Ⓢ	1.4	\$614	\$634
	30”H x 30”W	HRVT3030G	21 Ⓢ	1.8	\$657	\$677
	30”H x 36”W	HRVT3036G	22 Ⓢ	2.1	\$699	\$719
	30”H x 42”W	HRVT3042G	25 Ⓢ	2.4	\$757	\$777
	30”H x 48”W	HRVT3048G	28 Ⓢ	2.9	\$811	\$831
	30”H x 60”W	HRVT3060G	33 Ⓢ	3.4	\$953	\$973

! Segment bars ordered separately. See page 412.

NOTES:

- Glass is off-set and may be placed on either side of the frame.
- Tile is a single-pane, tempered glass.
- For worksurfaces that can be used with both Abound® and Accelerate® systems, see pages 568-578.
- ⚠ Glass tiles have a Class A fire rating.
- ! Tiles do not include segment bars, must be ordered separately. See page 412. Can be used in any combination.
- ! Glass tiles cannot be placed in the second tier (20”-35” range) due to interference with the horizontal support. Glass tiles cannot be placed in the bottom tier of a frame.
- ! Glass tiles will not work with 42”H frames — use stackers with glass on 42½”H panels.
- ! When stacking on 42½”H frames, panel slots will be off by ½” compared to any other height panel.

HOW TO SPECIFY

<p>Select Model Number</p> <div style="border: 1px solid black; display: flex; gap: 2px; padding: 2px;"> HRVT1524G </div>	<p>Select Interior Shroud Paint Color</p> <p>See page 391. Available in all P1/P2 paint colors.</p> <div style="border: 1px solid black; display: flex; gap: 2px; padding: 2px;"> T1 </div>
--	---

ABOUND® Frosted Glass Tiles

GSA SIN 33721



Icon Legend on page 19

WORKSTATIONS

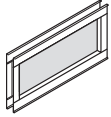

DESCRIPTION

15" H Frosted Glass Tiles

15" H x 24" W
15" H x 30" W
15" H x 36" W
15" H x 42" W
15" H x 48" W
15" H x 60" W

MODEL

SHIP WEIGHT

CUBE

LIST PRICE BY PAINT GRADE

P1

P2

HRVT1524R	12 Ⓢ	0.8	\$569	\$588
HRVT1530R	15 Ⓢ	0.9	\$610	\$629
HRVT1536R	17 Ⓢ	1.1	\$652	\$671
HRVT1542R	19 Ⓢ	1.3	\$699	\$719
HRVT1548R	20 Ⓢ	1.5	\$754	\$774
HRVT1560R	26 Ⓢ	1.8	\$881	\$901

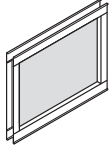

30" H Frosted Glass Tiles

30" H x 24" W
30" H x 30" W
30" H x 36" W
30" H x 42" W
30" H x 48" W
30" H x 60" W

HRVT3024R	15 Ⓢ	1.4	\$804	\$824
HRVT3030R	21 Ⓢ	1.8	\$860	\$880
HRVT3036R	22 Ⓢ	2.1	\$914	\$934
HRVT3042R	25 Ⓢ	2.4	\$985	\$1005
HRVT3048R	28 Ⓢ	2.9	\$1054	\$1074
HRVT3060R	33 Ⓢ	3.4	\$1210	\$1230

! Segment bars ordered separately. See page 412.

NOTES:

- Glass is off-set and may be placed on either side of the frame.
- Tile is a single-pane, tempered glass.
- For worksurfaces that can be used with both Abound® and Accelerate® systems, see pages 568-578.
- Ⓢ Glass tiles have a Class A fire rating.
- ! Tiles do not include segment bars, must be ordered separately. See page 412. Can be used in any combination.
- ! Glass tiles cannot be placed in the second tier (20"-35" range) due to interference with the horizontal support. Glass tiles cannot be placed in the bottom tier of a frame.
- ! Glass tiles will not work with 42"H frames — use stackers with glass on 42½"H panels.
- ! When stacking on 42½"H frames, panel slots will be off by ½" compared to any other height panel.

HOW TO SPECIFY

Select
Model Number

Select
Interior Shroud Paint Color

See page 391. Available in all P1/P2 paint colors.

HRVT1524R . T1



Icon Legend on page 19

ABOUND® Frameless Glass

WORKSTATIONS

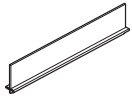

DESCRIPTION

7 1/2" H Frameless Glass

- 7 1/2" H x 24" W
- 7 1/2" H x 30" W
- 7 1/2" H x 36" W
- 7 1/2" H x 42" W
- 7 1/2" H x 48" W
- 7 1/2" H x 54" W (24" + 30")
- 7 1/2" H x 60" W
- 7 1/2" H x 66" W (30" + 36")
- 7 1/2" H x 72" W (36" + 36")
- 7 1/2" H x 78" W (48" + 30")
- 7 1/2" H x 84" W (36" + 48" or 42" + 42")
- 7 1/2" H x 90" W (42" + 48")
- 7 1/2" H x 96" W (48" + 48" or 36" + 60")

MODEL	SHIP WEIGHT	CUBE	CLEAR GLASS	FROSTED GLASS
HRVT0724F	18	0.5	\$410	\$445
HRVT0730F	18	0.5	\$440	\$477
HRVT0736F	21	0.6	\$509	\$552
HRVT0742F	25	0.7	\$538	\$584
HRVT0748F	28	0.8	\$574	\$624
HRVT0754F	28	0.8	\$639	\$693
HRVT0760F	35	1.0	\$702	\$763
HRVT0766F	35	1.0	\$769	\$835
HRVT0772F	42	1.9	\$835	\$907
HRVT0778F	42	1.9	\$898	\$975
HRVT0784F	50	2.1	\$958	\$1041
HRVT0790F	50	2.1	\$1023	\$1110
HRVT0796F	57	2.4	\$1083	\$1175

NOTES: For models 54" W-96" W, glass can span multiple panel widths. See examples of panel sizes by glass width above.

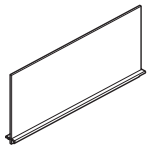

15" H Frameless Glass

- 15" H x 24" W
- 15" H x 30" W
- 15" H x 36" W
- 15" H x 42" W
- 15" H x 48" W
- 15" H x 54" W (24" + 30")
- 15" H x 60" W
- 15" H x 66" W (30" + 36")
- 15" H x 72" W (36" + 36")
- 15" H x 78" W (48" + 30")
- 15" H x 84" W (36" + 48" or 42" + 42")
- 15" H x 90" W (42" + 48")
- 15" H x 96" W (48" + 48" or 36" + 60")

HRVT1524F	28	1.5	\$461	\$498
HRVT1530F	28	1.5	\$491	\$532
HRVT1536F	34	1.8	\$569	\$616
HRVT1542F	39	2.0	\$605	\$655
HRVT1548F	45	2.3	\$648	\$702
HRVT1554F	51	2.6	\$716	\$777
HRVT1560F	57	2.8	\$788	\$854
HRVT1566F	62	3.2	\$863	\$935
HRVT1572F	67	3.5	\$937	\$1015
HRVT1578F	63	3.7	\$1066	\$1154
HRVT1584F	78	3.9	\$1190	\$1289
HRVT1590F	74	4.2	\$1224	\$1326
HRVT1596F	89	4.4	\$1260	\$1366

NOTES: For models 54" W-96" W, glass can span multiple panel widths. See suggested panel sizes by glass width above.

NOTES:

- Tile is a single-pane, 3/8" laminated safety glass.
- Available in clear or frosted glass.
- New top cap ships with Frameless Glass which fits around the glass insert.
- Frameless Glass can span multiple panels with one piece of glass.
- Lamination is in the center of the glass, making both clear and frosted glass a writable surface with dry-erase markers.
- ⚠ Glass tiles have a Class A fire rating.
- ⚠ Frameless Glass can only be used on the top of panels. Glass integrates into top cap trim.
- ⚠ Power and data cords cannot lay in the top of panel frames when using frameless glass.
- ⚠ Variable height trim for Frameless Glass must be ordered when using panel heights one step up; see page 418.
- ⚠ Cannot hang or stack on top of Frameless Glass.
- ⚠ Abound® power pole cannot be used with Frameless Glass. Freestanding power pole HH870070 can be used at the end of run or one panel needs to be specified without Frameless Glass for ceiling in-feed to enter the panel.

HOW TO SPECIFY

<p>Select Model Number</p> <div style="border: 1px solid black; display: flex; justify-content: space-between; padding: 2px;"> HRVT0724F </div>	<p>Select Glass Option</p> <p>G Clear R Frosted (Not specified for HRVT24R-60R models)</p> <div style="border: 1px solid black; display: flex; justify-content: space-between; padding: 2px;"> G </div>	<p>Select Paint Color</p> <p>See page 391 P1 Paint (no upcharge) P2 Paint (\$17 upcharge)</p> <div style="border: 1px solid black; display: flex; justify-content: space-between; padding: 2px;"> T1 </div>
---	---	--

ABOUND[®] Pass-thru Tiles

GSA SIN 33721



Icon Legend on page 19

WORKSTATIONS

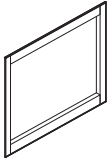

DESCRIPTION	MODEL	SHIP WEIGHT	CUBE	LIST PRICE BY PAINT GRADE	
				P1	P2
30"H Pass-Thru Tile Kit					
22½"H x 24"W	HRVT3024P	8	1.2	\$128	\$148
22½"H x 30"W	HRVT3030P	8	1.5	\$146	\$166
22½"H x 36"W	HRVT3036P	9	1.8	\$160	\$180
22½"H x 42"W	HRVT3042P	10	2.1	\$167	\$187
22½"H x 48"W	HRVT3048P	11	2.3	\$185	\$205
22½"H x 60"W	HRVT3060P	12	2.9	\$192	\$212

NOTES: Pass-thru opening is 22½"H. To be used with 30"H tiles. Order one 7½"H fabric tiles per pass-thru tile, if finishing only one side of panel.

❗ Must order a quantity of two (2) 7½"H fabric tiles per pass-thru tile, if finishing both sides of panel.

HOW TO SPECIFY

<p>Select Model Number</p> <p>HRVT3024P</p>	<p>Select Paint Color</p> <p>See page 391</p> <p>T1</p>
---	---

DESCRIPTION	MODEL	SHIP WEIGHT	CUBE	LIST PRICE BY FABRIC GRADE								
				AA	A	B	C	D	E	F	G	
7½"H Fabric Tackable Tile												
7½"H x 24"W	HRVT0724T	2 Ⓢ	1.4	\$62	\$66	\$69	\$71	\$77	\$82	\$87	\$90	
7½"H x 30"W	HRVT0730T	2 Ⓢ	1.8	\$73	\$77	\$80	\$84	\$90	\$97	\$100	\$103	
7½"H x 36"W	HRVT0736T	2 Ⓢ	2.1	\$78	\$82	\$85	\$89	\$95	\$102	\$105	\$108	
7½"H x 42"W	HRVT0742T	2 Ⓢ	2.4	\$86	\$91	\$95	\$99	\$109	\$112	\$116	\$120	
7½"H x 48"W	HRVT0748T	2 Ⓢ	2.8	\$92	\$97	\$101	\$105	\$115	\$118	\$122	\$126	
7½"H x 60"W	HRVT0760T	3 Ⓢ	3.4	\$110	\$130	\$134	\$139	\$151	\$155	\$158	\$161	

NOTES:

• Order one 7½"H fabric tiles per pass-thru tile, if finishing only one side of panel.

❗ Must order a quantity of two (2) 7½"H fabric tiles per pass-thru tile, if finishing both sides of panel.

HOW TO SPECIFY

<p>Select Model Number</p> <p>HRVT0724T</p>	<p>Select Fabric Color</p> <p>See pages 392-393</p> <p>APN15</p>
---	--



ABOUND[®] Slotted Tool Tiles

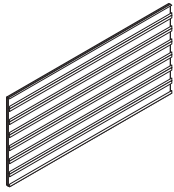

DESCRIPTION	MODEL	SHIP WEIGHT	CUBE	LIST PRICE BY PAINT GRADE		
				P1	P2	P3
15" H Slotted Tool Tiles						
15" H x 24" W	HRVT1524W	11 Ⓔ	0.8	\$259	\$288	\$311
15" H x 30" W	HRVT1530W	13 Ⓔ	0.9	\$279	\$308	\$335
15" H x 36" W	HRVT1536W	15 Ⓔ	1.1	\$298	\$327	\$358
15" H x 42" W	HRVT1542W	17 Ⓔ	1.3	\$318	\$347	\$382
15" H x 48" W	HRVT1548W	20 Ⓔ	1.5	\$337	\$366	\$404
15" H x 60" W	HRVT1560W	24 Ⓔ	1.8	\$357	\$386	\$428

ⓘ Segment bars ordered separately. See page 412.

NOTES:

- Tiles made from sturdy aluminum extrusion and steel supports with a powder coat finish.
- Choose from hang-on accessories for a variety of organizational options. See page 430.
- ⓘ Tiles do not include segment bars, must be ordered separately. See page 412. Can be used in any combination.
- ⓘ Weight capacity of hang-on accessories should not exceed 80 pounds.

HOW TO SPECIFY

<p>Select Model Number</p> <p>HRVT1524W</p>	<p>Select Paint Color</p> <p>See page 824 P1, P2, and P3 Paint Option</p> <p>P8S</p>
---	--



SYSTEMS PAPER MANAGEMENT SUPPORT BAR

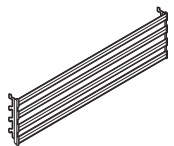

DESCRIPTION	MODEL	SHIP WEIGHT	CUBE	LIST PRICE BY PAINT GRADE		
				P1	P2	P3
Systems Paper Management Support Bars						
24" W x 5" H	HNPBSW24	1.3 Ⓔ	0.4	\$196	\$208	\$218
30" W x 5" H	HNPBSW30	1.5 Ⓔ	0.5	\$209	\$221	\$231
36" W x 5" H	HNPBSW36	2.0 Ⓔ	0.6	\$216	\$228	\$238
42" W x 5" H	HNPBSW42	5.0 Ⓔ	0.7	\$228	\$240	\$250
48" W x 5" H	HNPBSW48	7.0 Ⓔ	0.8	\$237	\$249	\$259
60" W x 5" H	HNPBSW60	9.0 Ⓔ	0.9	\$269	\$281	\$291

ⓘ Recommended weight capacity not to exceed 80 pounds.

NOTES:

- Paper management bar attaches to Systems Panels to accommodate work flow accessories.

HOW TO SPECIFY

<p>Select Model Number</p> <p>HNPBSW24</p>	<p>Select Paint Color</p> <p>See page 824 P1, P2, and P3 Paint Option</p> <p>P8S</p>
--	--





SYSTEMS PAPER MANAGEMENT ACCESSORIES

GSA SIN 33721

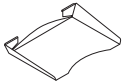
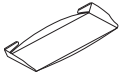

Icon Legend on page 19

WORKSTATIONS

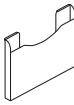
	DESCRIPTION	MODEL	SHIP WEIGHT	CUBE	LIST PRICE BY PAINT GRADE		
					P1	P2	P3
	Accessories for Slotted Tool Tiles Paper Shelf 15"W x 9½"D x 2"H NOTES: Paper Shelf holds letter size paper and inter-office envelopes.	HPPMPS	2 Ⓞ	0.3	\$97	\$109	\$120
	Accessory Shelf 21¾"W x 9"D x 2"H NOTES: Accessory Shelf holds office supplies and personal effects.	HPPMAS	2 Ⓞ	0.3	\$101	\$113	\$124
	Tray 9"W x 10¾"D x 2"H	HPPMPT	2 Ⓞ	0.3	\$124	\$136	\$147
	Pencil Holder 5¼"W x 1½"D x 5"H	HPPMPB	1 Ⓞ	0.2	\$101	\$113	\$124
	Sorter Tray 6"W x 10"D x 2½"H NOTES: Sorter Tray provides 3 slots for organizing files.	HPPMST	2 Ⓞ	0.3	\$133	\$145	\$156
	Folder Bin 12¼"W x 1¼"D x 9"H NOTES: Folder Bin accommodates manila envelopes and can be hung from other folder binds to maximize storage.	HPPMFB	2 Ⓞ	0.3	\$101	\$113	\$124

NOTES:











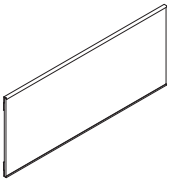

- For use with Slotted Tool Tiles and Systems Paper Management Support Bars on page 429.

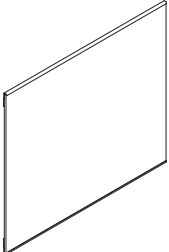
HOW TO SPECIFY



<p>Select Model Number</p>	<p>Select Paint Color</p> <p>See page 824 P1, P2, and P3 Paint Option</p>
<p>H P P M P S .</p>	<p>P 8 S</p>



Icon Legend on page 19

	DESCRIPTION	MODEL	SHIP WEIGHT	CUBE	LIST PRICE
	15”H Tiles				
	15”H x 24”W	HRVT1524M	4 	1.2	\$236
	15”H x 30”W	HRVT1530M	4 	1.8	\$253
	15”H x 36”W	HRVT1536M	5 	2.5	\$264
	15”H x 42”W	HRVT1542M	5 	3.4	\$281
	15”H x 48”W	HRVT1548M	6	4.3	\$288
	15”H x 60”W	HRVT1560M	7	6.7	\$300
	30”H Tiles				
	30”H x 24”W	HRVT3024M	6 	1.2	\$258
	30”H x 30”W	HRVT3030M	7 	1.8	\$278
	30”H x 36”W	HRVT3036M	8 	2.5	\$304
	30”H x 42”W	HRVT3042M	10 	3.4	\$325
	30”H x 48”W	HRVT3048M	11	4.3	\$357
	30”H x 60”W	HRVT3060M	13	6.7	\$395
	Magnetic Tray 15” Natural Aluminum	HRVTRAYM	4 	0.4	\$59
	 Natural Aluminum only, no need to specify paint.				

NOTES:

- tile has a painted, steel surface.
- Accepts magnetic accessories.
- tray attaches to the tile magnetically. Order separately.
-  Files do not include segment bars, must be ordered separately. See page 412. Can be used in any combination.
-  **cleaning instructions:** For everyday cleaning, use Chlorox® wipes. Use citrus cleaner if a permanent marker is used by accident. A citrus cleaner is not recommended for everyday use as it leaves residue.

HOW TO SPECIFY

<p>Select Model Number</p> <p>H R V T 1 5 2 4 M</p>	<p>Select Paint Color</p> <p>X No Specification Needed</p> <p>X</p>
--	--

ABOUND[®] Painted Metal Tiles

GSA SIN 33721



Icon Legend on page 19

WORKSTATIONS

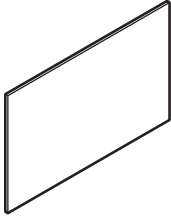

DESCRIPTION

15'H Painted Metal Tile

15"H x 24"W
15"H x 30"W
15"H x 36"W
15"H x 42"W
15"H x 48"W
15"H x 60"W

MODEL

SHIP WEIGHT

CUBE

LIST PRICE BY PAINT GRADE

P1

P2

HRVT1524PM	4	1.2	\$151	\$172
HRVT1530PM	4	1.8	\$160	\$181
HRVT1536PM	5	2.5	\$174	\$195
HRVT1542PM	5	3.4	\$187	\$208
HRVT1548PM	6	4.3	\$205	\$226
HRVT1560PM	7	6.7	\$227	\$248

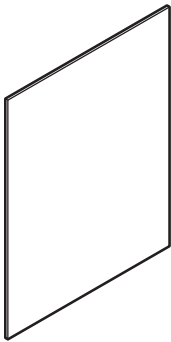

30'H Painted Metal Tile

30"H x 24"W
30"H x 30"W
30"H x 36"W
30"H x 42"W
30"H x 48"W
30"H x 60"W

HRVT3024PM	6	1.2	\$220	\$253
HRVT3030PM	7	1.8	\$239	\$272
HRVT3036PM	8	2.5	\$269	\$302
HRVT3042PM	10	3.4	\$288	\$321
HRVT3048PM	11	4.3	\$322	\$355
HRVT3060PM	13	6.7	\$361	\$394

NOTES:

- Painted steel construction.

! Tiles do not include segment bars, must be ordered separately. See page 412. Can be used in any combination.

HOW TO SPECIFY

Select
Model Number

Select
Paint Color

See page 391

HRVT1524PM.

T3

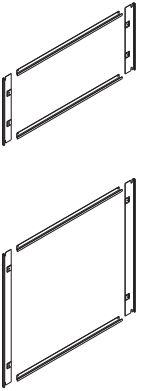

ABOUND® Custom Material Bracket Kit

	DESCRIPTION	MODEL	SHIP WEIGHT	CUBE	LIST PRICE
	Custom Material Mounting Bracket Kit				
	15"H x 24"W	HRVT1524CK	1 ☹	0.8	\$65
	15"H x 30"W	HRVT1530CK	1 ☹	0.9	\$70
	15"H x 36"W	HRVT1536CK	1 ☹	1.1	\$74
	15"H x 42"W	HRVT1542CK	1 ☹	1.3	\$76
	15"H x 48"W	HRVT1548CK	2 ☹	1.5	\$80
	15"H x 60"W	HRVT1560CK	2 ☹	1.8	\$89
	30"H x 24"W	HRVT3024CK	3 ☹	1.4	\$65
	30"H x 30"W	HRVT3030CK	3 ☹	1.8	\$70
	30"H x 36"W	HRVT3036CK	3 ☹	2.1	\$74
	30"H x 42"W	HRVT3042CK	4 ☹	2.4	\$76
	30"H x 48"W	HRVT3048CK	5 ☹	2.8	\$80
30"H x 60"W	HRVT3060CK	5 ☹	3.4	\$89	

NOTES: Custom Material Bracket Kits can be ordered to use with Customer's Own Material. Please contact HON Customer Support for exact dimensions if further information is needed.

	Coat Hooks				
	Package of six	HHPMC6	1 ☹	0.2	\$87

NOTES: Compatible with Accelerate® and Abound® panels. Coat hooks hang directly into slotted Abound panel frame.
 ☹ Black only. Ship 6 per package.

HOW TO SPECIFY

Select Model Number

H	R	V	T	1	5	2	4	C	K
---	---	---	---	---	---	---	---	---	---

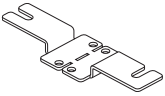
	DESCRIPTION	MODEL	SHIP WEIGHT	CUBE	LIST PRICE
	Abound® Anchor Bracket				
	Package of ten	HRABAB	5 ☹	0.08	\$85

NOTES: For use when panels need to be anchored to the floor such as high traffic areas or community spaces.
 ☹ Only available in Black (P).
 ☹ Only for use at the end of a wing panel.
SPECIFYING EXAMPLE: HRABAB.P

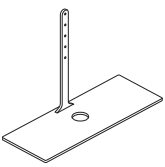
	DESCRIPTION	MODEL	SHIP WEIGHT		LIST PRICE BY PAINT GRADE	
			WEIGHT	CUBE	P1	P2
	Abound® Stability Foot	HRFTAB	3	0.1	\$374	\$384
	NOTES: Stabilizes bottom of panel from movement. Will not prohibit movement at top of panel. ☹ Only for use at the end of a wing panel.					

NOTES:

- ☹ The Anchor Bracket and Stability Foot are not intended to create a freestanding panel. Please follow Abound® stability standards.
- ☹ Attachment hardware for floor anchor not included.

HOW TO SPECIFY

Select Model Number	Select Paint Color								
See page 391									
<table border="1"> <tr> <td>H</td><td>R</td><td>F</td><td>T</td><td>A</td><td>B</td> </tr> </table>	H	R	F	T	A	B	<table border="1"> <tr> <td>T</td><td>1</td> </tr> </table>	T	1
H	R	F	T	A	B				
T	1								

ABOUND[®] Gallery Panels — Wing

OPEN MARKET



Icon Legend on page 19

WORKSTATIONS

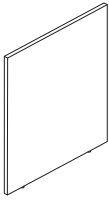

DESCRIPTION	MODEL	SHIP WEIGHT	CUBE	LIST PRICE BY LAMINATE GRADE	
				L1	L2
Wing End of Run					
35"H x 27"W	HRVG3527L	30.1	2.5	\$348	\$365
35"H x 33"W	HRVG3533L	36.8	3.0	\$423	\$444
35"H x 39"W	HRVG3539L	43.6	3.6	\$479	\$503
35"H x 45"W	HRVG3545L	50.3	4.1	\$532	\$559
42"H x 27"W	HRVG4227L	42.5	2.9	\$382	\$401
42"H x 33"W	HRVG4233L	50.0	3.6	\$464	\$487
42"H x 39"W	HRVG4239L	58.0	4.2	\$527	\$553
42"H x 45"W	HRVG4245L	65.0	4.8	\$569	\$597
42"H x 51"W	HRVG4251L	73.5	5.4	\$630	\$661
42"H x 63"W	HRVG4263L	89.0	6.7	\$708	\$743
50"H x 27"W	HRVG5027L	49.0	3.5	\$439	\$461
50"H x 33"W	HRVG5033L	58.0	4.2	\$514	\$540
50"H x 39"W	HRVG5039L	67.5	4.9	\$574	\$603
50"H x 45"W	HRVG5045L	77.0	5.6	\$649	\$681
50"H x 51"W	HRVG5051L	86.0	6.4	\$683	\$717
50"H x 63"W	HRVG5063L	104.5	7.8	\$767	\$805

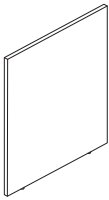

Wing Middle					
35"H x 24"W	HRVG3524L	26.8	2.4	\$330	\$346
35"H x 30"W	HRVG3530L	33.5	2.9	\$402	\$422
35"H x 36"W	HRVG3536L	40.2	3.3	\$448	\$470
35"H x 42"W	HRVG3542L	46.9	3.8	\$501	\$526
35"H x 48"W	HRVG3548L	53.6	4.4	\$554	\$582
35"H x 60"W	HRVG3560L	67.0	5.4	\$638	\$670
42"H x 24"W	HRVG4224L	38.5	2.6	\$362	\$380
42"H x 30"W	HRVG4230L	46.0	3.3	\$441	\$463
42"H x 36"W	HRVG4236L	54.0	3.9	\$492	\$517
42"H x 42"W	HRVG4242L	62.0	4.5	\$550	\$577
42"H x 48"W	HRVG4248L	69.5	5.1	\$592	\$622
42"H x 60"W	HRVG4260L	85.0	6.3	\$690	\$724
50"H x 24"W	HRVG5024L	44.5	3.1	\$417	\$438
50"H x 30"W	HRVG5030L	53.0	3.8	\$490	\$514
50"H x 36"W	HRVG5036L	63.0	4.6	\$541	\$568
50"H x 42"W	HRVG5042L	72.0	5.3	\$605	\$635
50"H x 48"W	HRVG5048L	81.5	6.0	\$666	\$699
50"H x 60"W	HRVG5060L	100.0	7.5	\$752	\$790

NOTES:

- When specifying Wing End of Run panels, the Gallery Panels are 3" wider to allow for the panel to cover the width of the spine.
- Mid-configuration creates 1/8" space between the system panels. This gap matches the thickness of the Gallery Panel.
- Gallery Panels come standard with two adjustable leveling guides.
- Gallery Panels require connectors to attach to the spine of the panel. See connectors on page 437.
- Gallery Panels up to 60"W can specify vertical or horizontal woodgrain direction. Panels larger than 60"W will have horizontal woodgrain.
- ! Minimum system panel length must be 50% of the Gallery Panel for stability.
- ! When system panel is higher than the Gallery Panel, system's variable height trim must be specified to finish off the exposed frame.
- ! Gallery Panels can only connect to standard panel frames; Gallery Panels cannot connect to each other.

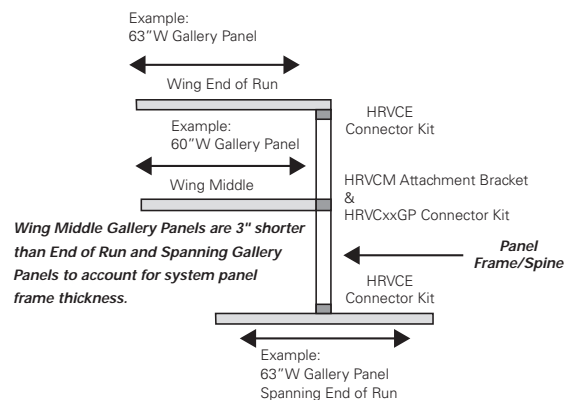

HOW TO SPECIFY

<p>Select Model Number</p> <p>HRVG3527L</p>	<p>Select Laminate</p> <p>See page 391</p> <p>C</p>	<p>Select Edge</p> <p>See page 391</p> <p>C</p>	<p>Select Grain Direction</p> <p>VST Vertical Grain (not available on 63"W or wider)</p> <p>VLG Horizontal Grain and Solid Laminate only</p> <p>VST</p>	<p>Select Glide</p> <p>G Glide</p> <p>G</p>
--	--	--	--	--

ABOUND[®] Gallery Panels — Wing

OPEN MARKET



Icon Legend on page 19

WORKSTATIONS

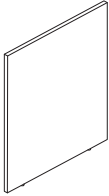

DESCRIPTION	MODEL	SHIP WEIGHT	CUBE	LIST PRICE BY LAMINATE GRADE	
				L1	L2
Spanning End of Run					
35"H x 51"W	HRVG3551L	57.0	4.6	\$573	\$602
35"H x 63"W	HRVG3563L	70.4	5.7	\$652	\$683
35"H x 75"W	HRVG3575L	83.8	6.7	\$794	\$734
42"H x 51"W	HRVG4251L	73.5	5.4	\$630	\$661
42"H x 63"W	HRVG4263L	89.0	6.7	\$708	\$743
42"H x 75"W	HRVG4275L	104.5	7.9	\$817	\$858
50"H x 51"W	HRVG5051L	86.0	6.4	\$683	\$717
50"H x 63"W	HRVG5063L	104.5	7.8	\$767	\$805
50"H x 75"W	HRVG5075L	123.0	9.3	\$889	\$933

NOTES:

- Gallery Panels come standard with two adjustable leveling guides.
- Gallery Panels require connectors to attach to the spine of the panel. See connectors on page 437.
- Gallery Panels up to 60"W can specify vertical or horizontal woodgrain direction. Panels larger than 60"W will have horizontal woodgrain.
- ! Minimum system panel length must be 50% of the Gallery Panel for stability.
- ! When system panel is higher than the Gallery Panel, system's variable height trim must be specified to finish off the exposed frame.
- ! Gallery Panels can only connect to standard panel frames; Gallery Panels cannot connect to each other.

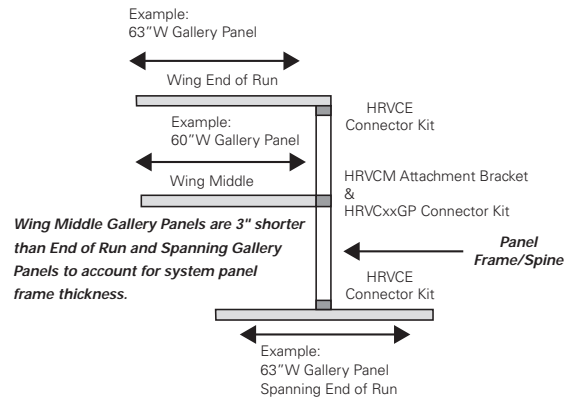

HOW TO SPECIFY

<p>Select Model Number</p> <p>HRVG3551L</p>	<p>Select Laminate</p> <p>See page 391</p> <p>C</p>	<p>Select Edge</p> <p>See page 391</p> <p>C</p>	<p>Select Grain Direction</p> <p>VST Vertical Grain (not available on 63"W or wider)</p> <p>VLG Horizontal Grain and Solid Laminate only</p> <p>VST</p>	<p>Select Glide</p> <p>G Glide</p> <p>G</p>
--	---	---	---	---



Gallery Panels — Wing, Accepts Glass

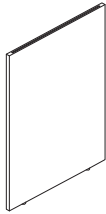

DESCRIPTION

Wing End of Run w/Glass

- 35”H x 27”W
- 35”H x 33”W
- 35”H x 39”W
- 35”H x 45”W

- 42”H x 27”W
- 42”H x 33”W
- 42”H x 39”W
- 42”H x 45”W
- 42”H x 51”W
- 42”H x 63”W

- 50”H x 27”W
- 50”H x 33”W
- 50”H x 39”W
- 50”H x 45”W
- 50”H x 51”W
- 50”H x 63”W

MODEL

SHIP WEIGHT CUBE

LIST PRICE BY LAMINATE GRADE
L1 L2

HRVG3527LG	30.1	2.5	\$473	\$497
HRVG3533LG	36.8	3.0	\$548	\$575
HRVG3539LG	43.6	3.6	\$605	\$635
HRVG3545LG	50.3	4.1	\$657	\$690
HRVG4227LG	42.5	2.9	\$508	\$533
HRVG4233LG	50.0	3.6	\$590	\$619
HRVG4239LG	58.0	4.2	\$652	\$685
HRVG4245LG	66.0	4.8	\$695	\$730
HRVG4251LG	73.5	5.4	\$755	\$793
HRVG4263LG	89.0	6.7	\$834	\$876
HRVG5027LG	49.0	3.5	\$564	\$592
HRVG5033LG	58.0	4.2	\$640	\$672
HRVG5039LG	67.5	4.9	\$699	\$734
HRVG5045LG	77.0	5.6	\$774	\$813
HRVG5051LG	86.0	6.4	\$808	\$848
HRVG5063LG	104.5	7.8	\$893	\$938

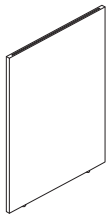

Wing Middle w/Glass

- 35”H x 24”W
- 35”H x 30”W
- 35”H x 36”W
- 35”H x 42”W
- 35”H x 48”W
- 35”H x 60”W

- 42”H x 24”W
- 42”H x 30”W
- 42”H x 36”W
- 42”H x 42”W
- 42”H x 48”W
- 42”H x 60”W

- 50”H x 24”W
- 50”H x 30”W
- 50”H x 36”W
- 50”H x 42”W
- 50”H x 48”W
- 50”H x 60”W

HRVG3524LG	26.8	2.4	\$455	\$478
HRVG3530LG	33.5	2.9	\$527	\$553
HRVG3536LG	40.2	3.3	\$574	\$603
HRVG3542LG	46.9	3.8	\$626	\$657
HRVG3548LG	53.6	4.4	\$679	\$713
HRVG3560LG	67.0	5.4	\$765	\$803
HRVG4224LG	38.5	2.6	\$487	\$511
HRVG4230LG	46.0	3.3	\$567	\$595
HRVG4236LG	54.0	3.9	\$618	\$649
HRVG4242LG	62.0	4.5	\$675	\$709
HRVG4248LG	69.5	5.1	\$717	\$753
HRVG4260LG	85.0	6.3	\$815	\$856
HRVG5024LG	44.5	3.1	\$542	\$569
HRVG5030LG	54.0	3.8	\$615	\$646
HRVG5036LG	63.0	4.6	\$667	\$700
HRVG5042LG	72.0	5.3	\$731	\$768
HRVG5048LG	81.5	6.0	\$774	\$814
HRVG5060LG	100.0	7.5	\$877	\$921

NOTES:

- When specifying Wing End of Run panels, the Gallery Panels are 3” wider to allow for the panel to cover the width of the spine.
- Mid-configuration creates 1½” space between the system panels. This gap matches the thickness of the Gallery Panel.
- Gallery Panels come standard with two adjustable leveling guides.
- Gallery Panels require connectors to attach to the spine of the panel. See connectors on page 437.
- Gallery Panels are notched to accept Frameless Glass. Frameless Glass sold separately. See page 436.
- Gallery Panels up to 60”W can specify vertical or horizontal woodgrain direction. Panels larger than 60”W will have horizontal woodgrain.

- ❗ Minimum system panel length must be 50% of the Gallery Panel for stability.
- ❗ When system panel is higher than the Gallery Panel, system’s variable height trim must be specified to finish off the exposed frame.
- ❗ Gallery Panels can only connect to standard panel frames; Gallery Panels cannot connect to each other.

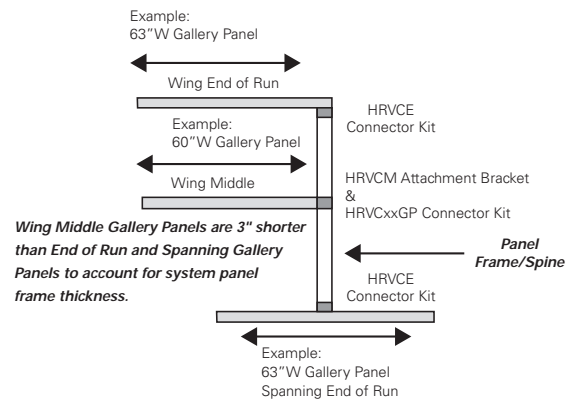

HOW TO SPECIFY

<p>Select Model Number</p> <p>HRVG 3527LG</p>	<p>Select Laminate</p> <p>See page 391</p> <p>C</p>	<p>Select Edge</p> <p>See page 391</p> <p>C</p>	<p>Select Grain Direction</p> <p>VST Vertical Grain (not available on 63”W or wider) VLG Horizontal Grain and Solid Laminate only</p> <p>VST</p>	<p>Select Glide</p> <p>G Glide</p> <p>G</p>
---	---	---	--	--



Gallery Panels — Wing, Accepts Glass

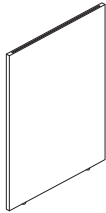

DESCRIPTION	MODEL	SHIP WEIGHT	CUBE	LIST PRICE BY LAMINATE GRADE	
				L1	L2
Spanning End of Run w/Glass					
35”H x 51”W	HRVG3551LG	57.0	4.6	\$698	\$733
35”H x 63”W	HRVG3563LG	70.4	5.7	\$779	\$818
35”H x 75”W	HRVG3575LG	83.5	6.7	\$915	\$961
42”H x 51”W	HRVG4251LG	73.5	5.4	\$755	\$793
42”H x 63”W	HRVG4263LG	89.0	6.7	\$834	\$876
42”H x 75”W	HRVG4275LG	104.5	7.9	\$942	\$989
50”H x 51”W	HRVG5051LG	86.0	6.4	\$808	\$848
50”H x 63”W	HRVG5063LG	104.5	7.8	\$893	\$938
50”H x 75”W	HRVG5075LG	123.0	9.3	\$1015	\$1066

NOTES:

- Gallery Panels come standard with two adjustable leveling guides.
 - Gallery Panels require connectors to attach to the spine of the panel. See connectors on page 437.
 - Gallery Panels are notched to accept Frameless Glass. Frameless Glass sold separately. See page 436.
 - Gallery Panels up to 60”W can specify vertical or horizontal woodgrain direction. Panels larger than 60”W will have horizontal woodgrain.
- ⓘ Minimum system panel length must be 50% of the Gallery Panel for stability.
- ⓘ When system panel is higher than the Gallery Panel, system’s variable height trim must be specified to finish off the exposed frame.
- ⓘ Gallery Panels can only connect to standard panel frames; Gallery Panels cannot connect to each other.

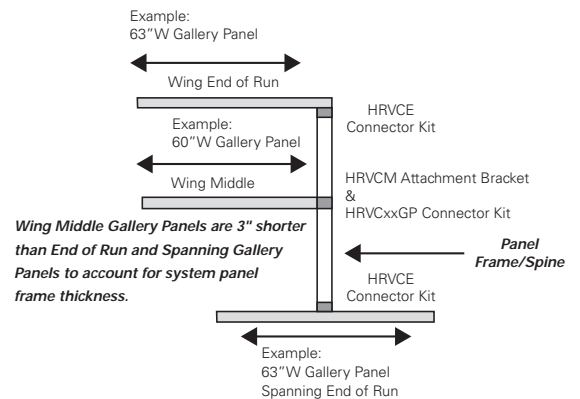

HOW TO SPECIFY

<p>Select Model Number</p> <p>HRVG3551LG</p>	<p>Select Laminate</p> <p>See page 391</p> <p>C</p>	<p>Select Edge</p> <p>See page 391</p> <p>C</p>	<p>Select Grain Direction</p> <p>VST Vertical Grain (not available on 63”W or wider)</p> <p>VLG Horizontal Grain and Solid Laminate only</p> <p>VST</p>	<p>Select Glide</p> <p>G Glide</p> <p>G</p>
--	---	---	---	---

ABOUND[®] Gallery Glass

OPEN MARKET



Icon Legend on page 19

WORKSTATIONS

	DESCRIPTION	MODEL	SHIP WEIGHT	CUBE	CLEAR GLASS	FROSTED GLASS
	7 1/2" H Gallery Glass, Wing, End of Run					
	For 27"D Panels	SPLH-ABND-GALGLSS.M482172	9.0	0.7	\$374	\$409
	For 33"D Panels	SPLH-ABND-GALGLSS.M482174	10.5	0.9	\$396	\$431
	For 39"D Panels	SPLH-ABND-GALGLSS.M482176	12.0	1.1	\$453	\$488
	For 45"D Panels	SPLH-ABND-GALGLSS.M482178	13.0	1.3	\$479	\$514
	For 51"D Panels	SPLH-ABND-GALGLSS.M482180	14.5	1.5	\$529	\$564
	7 1/2" H Gallery Glass, Middle					
	For 24"D Panels	SPLH-ABND-GALGLSS.M482171	8.0	0.7	\$365	\$400
	For 30"D Panels	SPLH-ABND-GALGLSS.M482173	10.0	0.8	\$385	\$420
	For 36"D Panels	SPLH-ABND-GALGLSS.M482175	11.0	1.0	\$405	\$440
	For 42"D Panels	SPLH-ABND-GALGLSS.M482177	12.5	1.2	\$465	\$500
	For 48"D Panels	SPLH-ABND-GALGLSS.M482179	14.0	1.4	\$509	\$544
	7 1/2" H Gallery Glass, Spanning End of Run					
	For 51"D Panels	SPLH-ABND-GALGLSS.M482180	14.5	1.5	\$529	\$564
	For 63"D Panels	SPLH-ABND-GALGLSS.M482182	17.0	1.8	\$622	\$657
	For 75"D Panels	SPLH-ABND-GALGLSS.M482183	19.5	2.2	\$735	\$770

NOTES:

- Gallery Panels are 3" wider than corresponding glass to allow for proper fit and function.
- Glass is inset 1/2" from end of Gallery Panel.
- ! Cannot hang or stack on top of Frameless Glass.
- ! Frameless Glass can only be used on the top of Gallery Panels. Glass integrates into notch cutout in the top of the panel.

HOW TO SPECIFY

<p>Select Model Number</p> <p>S P L H - A B N D - G A L G L S S . M 4 8 2 1 7 1 .</p>	<p>Select Glass</p> <p>Q Clear Glass R Frosted Glass</p> <p>Q</p>
---	---

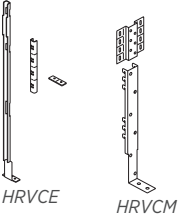

ABOUND[®] Gallery Connector Kits

	DESCRIPTION	MODEL	SHIP WEIGHT	CUBE	LIST PRICE BY PAINT GRADE	
					P1	P2
	Gallery Panel Connectors					
	Spanning End of Run and L Connector	HRVCE	0.83	0.1	\$75	\$82
	Wing Middle Attachment Brackets	HRVCM	0.62	0.1	\$86	\$95

	DESCRIPTION	MODEL	SHIP WEIGHT	CUBE	LIST PRICE
	Gallery Connector Kits				
	35"	HRVC35GP	1.0	0.3	\$170
	42"	HRVC42GP	1.5	0.4	\$190
	50"	HRVC50GP	1.5	0.5	\$200
	65"	HRVC65GP	2.0	0.6	\$232

	DESCRIPTION	MODEL	SHIP WEIGHT	CUBE	LIST PRICE
	Gallery Panel-to-Storage Kits				
	Laminate Storage Ganging Kit	HRVGLSK	0.1	0.1	\$41
	Metal Storage Ganging Kit	HRVGMSK	0.1	0.1	\$9

NOTES:

- HRVCE is used in L and spanning (T) end of run applications.
- Wing Middle Connector Kits accommodate both single-sided and dual-sided applications.
- For more rigidity, the Gallery Panel can be tied to a storage or a non-adjustable surface. Use HRVGLSK for laminate or HRVGMSK for metal storage.
- ❗ Wing Middle Connector Kits must be used in any Wing Middle application in conjunction with model HRVCM.
- ❗ Wing Middle Connector Kits are required for Wing Middle applications and are used only with Wing Middle Gallery Panels.
- ❗ Gallery Panels can only connect to standard panel frames; Gallery Panels cannot connect to each other.
- ❗ See Gallery Panel and Connector illustration on pages 434 and 435 for placement and application.

HOW TO SPECIFY

<p>Select Model Number</p> <p>HRVC42GP</p>	<p>Select Paint Color</p> <p>See page 391</p> <p>T1</p>
--	---

<p>Select Model Number</p> <p>HRVGMSK</p>

ABOUND[®] Gallery Panel

OPEN MARKET



Icon Legend on page 19

WORKSTATIONS

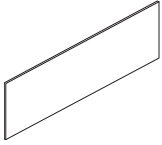

DESCRIPTION	MODEL	SHIP WEIGHT	CUBE	LIST PRICE BY FABRIC GRADE							
				AA	A	B	C	D	E	F	G
Gallery Panel 36"W x 11"H 36"W x 18½"H	HRVTB11	7	1.1	\$254	\$259	\$262	\$265	\$268	\$273	\$278	\$283
	HRVTB18	10	1.8	\$298	\$303	\$306	\$309	\$312	\$317	\$322	\$327

NOTES:

- attaches to Gallery Panel by screwing painted metal frame onto Gallery Panel surface. Fabric insert attaches to painted metal frame with hook and loop.
- Attachment hardware for is provided.
- ! No template is provided for placement and leveling of .

HOW TO SPECIFY

Select Model Number	Select Fabric
	See pages 392-393
HRVTB11	APN11

ACCELERATE®

WORKSTATIONS



Accelerate® 120° Degree Workstations shown with Contain® and Voi®.

ACCELERATE®

You know how quickly business can change. You have to be nimble. Adaptable. And you need an office space that can keep pace. That's Accelerate — a complete office system that maximizes style and comfort while minimizing startup time and costs. Trim, clean and modern, Accelerate's streamlined product line makes planning simple and ordering a breeze. So you can move at the speed your business needs.



FEATURES

- Customize your spaces! Add fabric stackers for height and privacy, or glass stackers to let the light in.
- Accelerate's crisp details have been designed to meet today's contemporary aesthetic. Clean. Minimal. Beautiful.
- Accelerate panels are compatible with other HON products, like Abode desks, Contain storage and more.
- The interchangeable components allow you to customize your space with a clean, contemporary look — and change your mind without changing your furniture.

ACCELERATE® ORDERING INFORMATION

WORKSURFACES, COUNTERTOPS, CORNER SHELVES W/EDGE BAND

L1 LAMINATES CODES

Woodgrain

◆ Bourbon Cherry	H
◆ Cognac	COGN
◆ Florence Walnut	LFW1
◆ Harvest	C
◆ Kingswood Walnut	LK11
◆ Mahogany	N
◆ Mocha	MOCH
◆ Natural Maple	D
◆ Pinnacle	PINC
◆ Shaker Cherry	F
◆ Sterling Ash	LSA1

Solid

◆ Black	P
◆ Charcoal	S
◆ Designer White	LDW1
◆ Loft	LOFT

Patterned

◆ Sheer Mesh	A5
◆ Silver Mesh	B9
◆ Steel Mesh	A9
◆ Canyon Zephyr	K9
◆ Desert Zephyr	K8
◆ Shadow Zephyr	K1
◆ Gray	G2
◆ Grey Tigris	L6
◆ White	G1
◆ Whitestone	K4

L2 LAMINATES CODES

Woodgrain

◆ Lowell Ash	LLA1
◆ Natural Recon	LNR1
◆ Phantom Ecru	LPE1
◆ Portico Teak	LPT1
◆ Skyline Walnut	LSW1

(Door panels not available in L2)

WORKSURFACE EDGE BAND

◆ Black	P
◆ Bourbon Cherry	H
◆ Charcoal	S
◆ Cognac	COGN
◆ Designer White	DW
◆ Florence Walnut	FW
◆ Greige	R
◆ Harvest	C
◆ Kingswood Walnut	KI
◆ Light Gray	Q
◆ Loft	LOFT
◆ Lowell Ash	DL
◆ Mahogany	N
◆ Mocha	MOCH
◆ Muslin	T
◆ Natural Maple	D
◆ Natural Recon	NR
◆ Phantom Ecru	PE
◆ Pinnacle	PINC
◆ Platinum	K
◆ Portico Teak	DP
◆ Shadow	SHDW
◆ Shaker Cherry	F
◆ Skyline Walnut	SW
◆ Sterling Ash	SA

WORKSURFACE GROMMET

◆ Black	P
◆ Brownstone	EY
◆ Charcoal	S
◆ Fossil	EH
◆ Greige	T5
◆ Light Gray	Q
◆ Loft	LOFT
◆ Muslin	T3
◆ Shadow	SHDW
◆ Titanium	T1
◆ Designer White	DW
◆ Champagne Metallic	T4
◆ Platinum Metallic	T1

FRAMES, TRIM, METAL TILES, CUSTOM BRACKET KIT, WORKSURFACE SUPPORTS, STEEL OVERHEAD STORAGE CHASSIS

PAINT CODES

◆ Black	P
◆ Brownstone	P7D
◆ Charcoal	S
◆ Designer White	PJW
◆ Fossil	P28
◆ Greige	T5
◆ Light Gray	Q
◆ Loft	LOFT
◆ Muslin	T3
◆ Putty	L
◆ Shadow	SHDW
◆ Titanium	P8T

◆ Champagne Metallic	T4
◆ Platinum Metallic	T1
◆ Silver	PR6
◆ Solar Black	P8X

DUPLEX/PORTED TILE

PLASTIC CODES

◆ Black	P
◆ Brownstone	P7D
◆ Charcoal	S
◆ Designer White	DW
◆ Loft	LOFT
◆ Muslin	T3
◆ Titanium	TI

Recommendations

Paint	Duplex-Data Code
Black P	Black P
Brownstone P7D	Brownstone EY
Charcoal S	Charcoal S
Designer White PJW	Designer White DW
Fossil P28	Charcoal S
Greige T5	Muslin T3
Light Gray Q	Loft LOFT
Loft LOFT	Loft LOFT
Muslin T3	Muslin T3
Putty L	Black P
Shadow SHDW	Muslin T3
Silver PR6	Titanium T1
Titanium P8T	Titanium T1
Champagne Metallic T4	Muslin T3
Platinum Metallic T1	Titanium T1

► LAMINATE TOPS

SPECIFY: Model Number.
Laminate.
Edge Color.
Grommet Color
EXAMPLE: HWR2424P.K8.R.T5

► PANELS

SPECIFY: Model Number.
Fabric
Paint
EXAMPLE: HETP3520FP.APN11.S

► CONNECTORS

SPECIFY: Model Number.
Paint
EXAMPLE: HEC35PS.T3

◆◆◆ For lead time information see page 19.

* De-emphasized

Replacement Duplex Receptacle Covers are made from a polymer material and are available in the following colors only:

Black	P
Muslin	T3
Shadow	SHDW

ACCELERATE[®] FABRIC PATTERNS & CODES

PRICE CODE AA

FACTOR	FACT
◆ Bark	FACT20
◆ Barley	FACT15
◆ Cascade	FACT25
◆ Feather	FACT30

PRICE CODE A

APPOINT	APN
◆ Artichoke	APN11
◆ Blackberry	APN32
◆ Bronze	APN22
◆ Carbon	APN28
◆ Chai	APN12
◆ Cherry	APN30
◆ Dark Pewter	APN17
◆ Dune	APN15
◆ Espresso	APN23
◆ Framboise	APN31
◆ Frost	APN34
◆ Jet	APN27
◆ Lawn	APN25
◆ Mandarin	APN29
◆ Morel	APN09
◆ Nimbus	APN16
◆ Platinum	APN24
◆ Turquoise	APN26

CENTURION CU

◆ Apricot	CU47
◆ Bark	CU25
◆ Black	CU10
◆ Espresso	CU49
◆ Fog	CU03
◆ Frost	CU22
◆ Goldenrod	CU27
◆ Indigo	CU06
◆ Iris	CU50
◆ Iron Ore	CU19
◆ Jade	CU83
◆ Marsala	CU63
◆ Morel	CU24
◆ Navy	CU98
◆ Peacock	CU97
◆ Pear	CU84
◆ Ruby	CU67
◆ Sapphire	CU09

PRICE CODE A *continued*

ETCH*	ECH
◆ Axis	ECH13
◆ Blend	ECH14
◆ Cast	ECH12
◆ Highlight	ECH10
◆ Midtone	ECH11
◆ Outline	ECH08
◆ Shade	ECH09
◆ Tonal	ECH16
◆ Vanish	ECH15

EXCHANGE* EXG

◆ Iron	EXG916
◆ Nickel	EXG914
◆ Pistachio	EXG910
◆ Root	EXG913
◆ Rupee	EXG903
◆ Shadow	EXG911
◆ Silver	EXG915
◆ Sisal	EXG917
◆ Stone	EXG912

LANDSCAPE* LN

◆ Azure	LN55
◆ Cornsilk	LN15
◆ Drift	LN05
◆ Khaki	LN20
◆ Sheen	LN10
◆ Slate	LN35
◆ Umber	LN25
◆ Urban	LN30

LUCY* LC

◆ Aspen	LC32
◆ Cornsilk	LC30
◆ Dusk	LC22
◆ Fawn	LC33
◆ Graphite	LC34
◆ Mist	LC20
◆ Neutra	LC24
◆ Pewter	LC35
◆ Snowdrop	LC28

PRICE CODE A *continued*

REFLECTIONS*	REF
◆ Galvanized	REF29
◆ Ice	REF20
◆ Loggia	REF21
◆ Mistral	REF28
◆ Moonstone	REF23
◆ Pewter	REF22
◆ Stainless	REF24
◆ Vanilla	REF25
◆ Winter	REF27

REFUGE* RFG

◆ Artesian	RFG96
◆ Dune	RFG92
◆ Eclipse	RFG90
◆ Frost	RFG93
◆ Glacier	RFG91
◆ Mineral	RFG98
◆ Tidal	RFG94

SARTO* SRT

◆ Ash	SRT88
◆ Fog	SRT14
◆ Lemongrass	SRT49
◆ Mist	SRT45
◆ Mushroom	SRT76
◆ Oyster	SRT18
◆ Reef	SRT64
◆ Sesame	SRT93
◆ Shale	SRT52

TEMPEST* TP

◆ Dragonfly	TP30
◆ Frost	TP15
◆ Full Stream	TP80
◆ Gold Rush	TP10
◆ Slate	TP45
◆ Tumbleweed	TP70
◆ Wind Chill	TP40
◆ Zebra	TP35

NOTES: Centurion fabric not available on panels that exceed a width and height of 54".

Analog, Disperse, and Exchange panel fabrics will be applied pattern cut. Disperse will not be available on 72"W panels.

◆◆◆ For lead time information see page 19.

* Directional fabrics

ACCELERATE[®] FABRIC PATTERNS & CODES

PRICE CODE B		PRICE CODE B <i>continued</i>		PRICE CODE B <i>continued</i>		PRICE CODE B <i>continued</i>	
DISPERSE*	DISP	MICA*	MCA	SPIN*	SPIN	TERRAIN*	TRRN
◆ Autumn	DISP03	◆ Anthracite	MCA11	◆ Alabaster	SPIN02	◆ Bay	TRRN05
◆ Branch	DISP10	◆ Breeze	MCA18	◆ Cavern	SPIN03	◆ Bayou	TRRN35
◆ Coffee Bean	DISP13	◆ Bronze	MCA13	◆ Cobblestone	SPIN04	◆ Canyon	TRRN30
◆ Dusk	DISP09	◆ Buff	MCA14	◆ Ember	SPIN06	◆ Cliff	TRRN45
◆ Emerald City	DISP08	◆ Cremini	MCA17	◆ Flame	SPIN07	◆ Crest	TRRN25
◆ Gold Rush	DISP02	◆ Crystal	MCAWIT	◆ Heron	SPIN13	◆ Delta	TRRN10
◆ Igloo	DISP11	◆ Dew	MCA20	◆ Oat	SPIN01	◆ Plateau	TRRN15
◆ Ink	DISP06	◆ Dove	MCA12	◆ Ocean	SPIN12	◆ Ridge	TRRN20
◆ Mist	DISP12	◆ Fresh	MCA16	◆ Plum	SPIN15	◆ Valley	TRRN40
◆ Oatmeal	DISP15	◆ Mineral	MCA15	◆ Pool	SPIN11		
◆ Prince	DISP07	◆ Nectar	MCA19	◆ Raven	SPIN10		
◆ Reservoir	DISP01	◆ Shale	MCA10	◆ Rhubarb	SPIN14		
◆ Rose	DISP04			◆ Tropic	SPIN08		
◆ Spring	DISP05			◆ Willow	SPIN05		
◆ Steel	DISP16						
◆ Taupe	DISP14						

NOTES: Disperse and Exchange panel fabrics will be applied pattern cut. Disperse will not be available on 72"W panels.

◆◆◆ For lead time information see page 19.

* Directional fabrics

ACCELERATE® Typicals



Icon Legend on page 19

WORKSTATIONS

QTY	DESCRIPTION	MODEL	FABRIC GRADE	LIST PRICE	PRICE EXTENSION
2	Accelerate® Top Cap 72"W	HETC72		\$100	\$200
2	Tackable Panel 50"H x 72"W	HETP5072FP		\$572	\$1,144
1	"L" Connector 50"H	HEC50PL		\$141	\$141
2	Panel Finished End Covers 50"H	HEFEC50P		\$56	\$112
2	Electrical Power Harness Panels w/Duplex Capacity	HH871272		\$214	\$428
1	Duplex Receptacle Circuit 1 3-1 & 2-2	HH871501		\$43	\$43
1	Duplex Receptacle Circuit 4 3-1 & 2-2	HH871504		\$43	\$43
1	Base In-Feed Cable Base 3-1 & 2-2	HH879072		\$227	\$227
1	Rectangular Worksurface 24"D x 48"W	HWR2448P		\$404	\$404
1	Rectangular Worksurface 24"D x 72"W	HWR2472P		\$529	\$529
1	24"D Cantilever - One Pair	HCTL242		\$84	\$84
1	Flat Bracket 24"D	HHN831124		\$64	\$64
1	External Stiffener 48"W	HLSL255C60		\$98	\$98
1	Flagship® Series Freestanding Pedestal "A" Pull B/B 15"W x 22 7/8"D x 28"H	H19723A		\$719	\$719
1	Flagship® Series Freestanding Pedestal "A" Pull F/F 15"W x 22 7/8"D x 28"H	H19823A		\$712	\$712
1	Pedestal-to-Panel Bracket, Left	HPD2PNBRK2L		\$107	\$107
1	Pedestal-to-Panel Bracket, Right	HPD2PNBRK2R		\$107	\$107
1	Lota® Mid-Back Chair	H2281	1	\$753	\$753
				TOTAL:	\$5,915

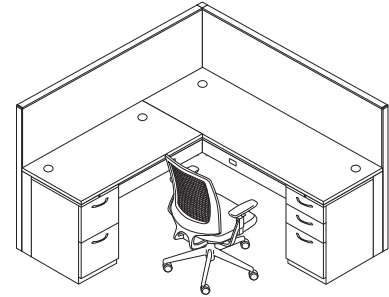

QTY	DESCRIPTION	MODEL	FABRIC GRADE	LIST PRICE	PRICE EXTENSION
2	Tackable Top-Tier Glass Panel 50"H x 20"W	HETP5020DP		\$500	\$1,000
2	Tackable Top-Tier Glass Panel 50"H x 42"W	HETP5042DP		\$592	\$1,184
5	Tackable Panel 65"H x 24"W	HETP6524FP		\$351	\$1,755
2	Tackable Panel 65"H x 48"W	HETP6548FP		\$450	\$900
2	Accelerate® Top Cap 72"W	HETC72		\$100	\$200
3	Accelerate® Top Cap 24"W	HETC24		\$36	\$108
2	Accelerate® Top Cap 20"W	HETC20		\$36	\$72
2	Accelerate® Top Cap 42"W	HETC42		\$59	\$118
4	Worksurface Bracket Kits	HWSB2		\$46	\$184
2	Flat Bracket 24"D	HHN831124		\$64	\$128
2	Straight Connector Kits	HSCKTPS		\$19	\$38
2	"L" Connector 50"H	HEC50PL		\$141	\$282
2	"L" Connector 65"H	HEC65PL		\$155	\$310
1	"T" Connector 65"H	HEC65PT		\$155	\$155
2	Panel Finished End Covers 50"H	HEFEC50P		\$56	\$112
1	Panel Finished End Covers 65"H	HEFEC65P		\$63	\$63
2	In-line Variable Height Finishing Kit 15"W	HEVHF15P		\$55	\$110
2	Electrical Power Harness 3-1 & 2-2 48"W	HH871248		\$214	\$428
1	Electrical Pass-Thru w/o Power Block 3-1 & 2-2 48"W	HH871048		\$123	\$123
1	Base In-Feed Cable Base 3-1 & 2-2	HH879072		\$227	\$227
1	Duplex Receptacle Circuit 1 3-1 & 2-2	HH871501		\$43	\$43
1	Duplex Receptacle Circuit 2 3-1 & 2-2	HH871502		\$43	\$43
1	Duplex Receptacle Circuit 4 3-1 & 2-2	HH871504		\$43	\$43
1	Duplex Receptacle Circuit 1 3-1 & 2-2	HH871506		\$43	\$43
2	Rectangular Worksurface 18"D x 42"W	HWR1842P		\$333	\$666
2	Rectangular Worksurface 24"D x 48"W	HWR2448P		\$404	\$808
2	Worksurface to Tower Bracket Kits	HSTB2W1		\$76	\$152
2	Stack-on Storage w/Sliding Doors 14 1/4"D x 48"W x 13"H	HLSL1448S		\$1,078	\$2,156
2	Voi® for Systems Stack-on Storage Panel Mounted Bracket	HLSLPMB		\$131	\$262
2	Voi® Mobile Pedestal 15 3/4"W x 21 1/16"D x 21 1/16"H	HLSL2016MP2	1	\$794	\$1,588
2	Voi® Pedestal Cushion	HLSL2016PH2	2	\$333	\$666
1	Voi® Personal Storage Tower (LH) 24"D x 24"W x 65"H	HLSLW446LP		\$2,609	\$2,609
1	Voi® Personal Storage Tower (RH) 24"D x 24"W x 65"H	HLSLW446RP		\$2,609	\$2,609
2	Nucleus® 4-Way Stretch Back Work Chair	HN1	1	\$856	\$1,712
				TOTAL:	\$20,897

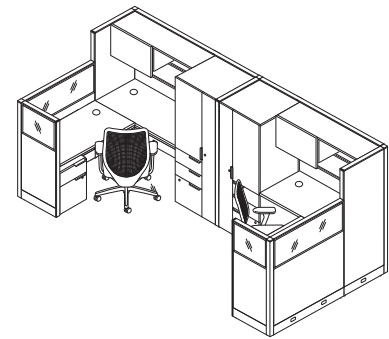



Icon Legend on page 19

ACCELERATE® Typicals

WORKSTATIONS

QTY	DESCRIPTION	MODEL	FABRIC GRADE	LIST PRICE	PRICE EXTENSION
1	In-Line Connector	HCKTTPS		\$19	\$19
2	Tackable Panel 42½"H x 24"W	HETP4224FP		\$290	\$580
2	Tackable Panel 42½"H x 60"W	HETP4260FP		\$406	\$812
2	Accelerate® Top Cap 60"W	HETC60		\$81	\$162
2	Accelerate® Top Cap 24"W	HETC24		\$36	\$72
4	Accelerate® Countertop Kit	HECB42		\$51	\$204
2	Worksurface Bracket Kit	HWSB2		\$46	\$92
1	Universal Support Leg 24"D	HRVCLG24		\$197	\$197
2	"L" Connector 42½"H	HEC42PL		\$123	\$246
2	Panel Finished End Covers 42½"H	HEFEC42P		\$52	\$104
1	Base In-Feed Cable Base 3-1 & 2-2	HH879072		\$227	\$227
1	Electrical Pass-Thru Cable w/Duplex For 24"W Panel	HH871124		\$128	\$128
2	Electrical Power Harness 3-1 & 2-2 60"W	HH871260		\$214	\$428
2	Duplex Receptacle Circuit 4 3-1 & 2-2	HH871504		\$43	\$86
2	Rectangular Worksurface 24"D x 60"W	HWR2460P		\$477	\$954
2	Straight Countertop 60"W x 15"D	HBCSR1560P		\$378	\$756
2	Flagship® Mobile Series Pedestal "A" Pull B/B/F 15"W x 22½"D x 28"H	H18723A		\$730	\$1,460
2	Ignition® Mid-Back Work Chair	HIWM3	1	\$762	\$1,524
				TOTAL:	\$8,051



QTY	DESCRIPTION	MODEL	FABRIC GRADE	LIST PRICE	PRICE EXTENSION
3	Systems Corner Worksurface w/ 120° Curve Edge 42"W x 24"D	HBWCT4224P		\$833	\$2,499
3	Systems 60° Wedge Worksurface Edgeband 24"W x 24"D	HCWQT2424P		\$393	\$1,179
3	120° 2-way Connector 35"H	HEC35P2		\$106	\$318
2	Panel Finished End Covers 35"H	HEFEC35P		\$49	\$98
4	Frameless Glass 15"H x 42"W	HEFG1542		\$545	\$2,180
4	Tackable Panel 35"H x 42"W	HETP3542FP		\$310	\$1,240
4	Electrical Power Harness 3-1 & 2-2 Systems 42"W	HH871242		\$214	\$856
1	Duplex Receptacle Circuit 1 3-1 & 2-2 Systems	HH871501		\$43	\$43
2	Duplex Receptacle Circuit 2 3-1 & 2-2 Systems	HH871502		\$43	\$86
2	Duplex Receptacle Circuit 3 3-1 System Only	HH871503		\$43	\$86
3	Duplex Receptacle Circuit 4 3-1 & 2-2 Systems	HH871504		\$43	\$129
1	Base In-Feed Cable Base 3-1 & 2-2 Systems	HH879072		\$227	\$227
3	Mobile Pedestal 20"W x 15½"D x 21½"H	HLSL2016MP2		\$794	\$2,382
3	Pedestal Cushion 20"W x 15½"D x 1"H	HLSL2016PH2	2	\$333	\$999
2	Abound® Left End Panel 29"H x 24"D	HRVEP2429L		\$223	\$446
2	Abound® Right End Panel 29"H x 24"D	HRVEP2429R		\$223	\$446
2	Systems Rectangular Worksurface Edgeband 24"D x 42"W	HWR2442P		\$380	\$760
6	Universal Support Leg 24"D	HRVCLG24		\$197	\$1,182
				TOTAL:	\$15,156

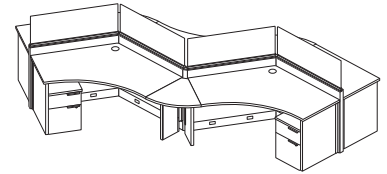

ACCELERATE® PANELS OVERVIEW

INTERSECTING CONNECTIONS

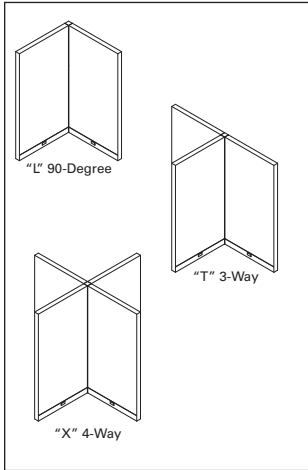

“L”, “T” and “X” connector kits are used when connecting frames at intersecting runs. For “L”, “T” and “X” connector kits, add 2¼” to the total length of the panel run for each intersection, whether located in the middle or at the end of the run.

Wall starter kits provide a means to affix a panel run to a permanent building wall. Kit adds ⅞” to length of panel run.

STACKING PANELS

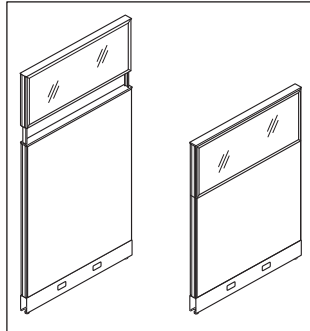

Stackers add 15” to the height of the base panel and can be ordered separately or as part of the panel model, see pages 451 and 454.

When adding stackers to an existing panel, a new connector must be ordered, to the tallest panel height.

Please note that Stacking Panels are not to be used freestanding and must match the panel width of the panel it is stacking on.

Cannot use a stacking panel on a Top Tier Glass Panel model.

Stackers ship with pins to connect stacker to post connector for added rigidity.

Stackers can be stacked up to 80”H on a base panel. Overheads can be placed on the first stacker only, up to 65”H. Voi overheads are not to be placed on stackers.

Top View			
Panel		Panel	
	→	← 2¼"	
Panel	S	Panel	

Extended straight connector kit “S” can be used to keep continuous runs dimensionally consistent with opposing panel runs which incorporate “T” or “X” intersections. (Add 2¼” to the length of the run for every extended straight connector used.)

IN-LINE CONNECTIONS

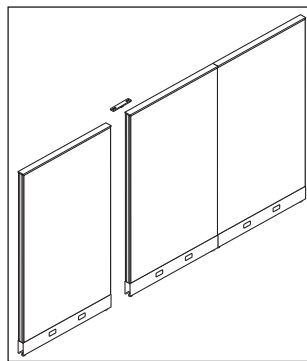

There is no incremental increase in dimension along the panel run when using an in-line connector kit.

END OF RUN

Finished end trim must be specified for the unconnected sides of panel. When adding a stacking panel, order finished end trim in the height that matches the total stacked height. Move the end cap from the standard frame end trim to the stacking frame end trim.

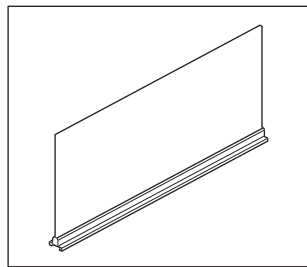

Accelerate® frameless glass is single pane, ⅜” thick laminate safety glass, available in clear or frosted glass.

Frameless glass can only be used on the tallest panel in a typical, not at in-line or post connectors with variable height. Frameless glass is not allowed on top of glass stackers or glass header panels and hanging or stacking on frameless glass is not permitted.

Frameless glass can span multiple panels with one piece of glass, creating a clean, seamless look.

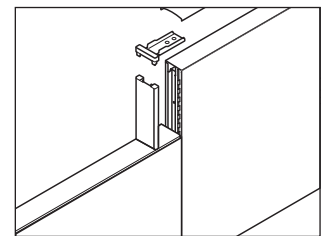

IN-LINE VARIABLE HEIGHT TRIM
In-line connections between different height panels require trim to cover the exposed frame of the taller panel.

VARIABLE HEIGHT CONNECTOR TRIM

L, X and T connections between different height panels require trim to cover the exposed connector. The bottom of the trim is flat to match the profile of the top cap. Models are designated as “Variable Height Connector Trim”. For variable height connections in a Y configuration, contact the Accelerate Specials Department.

Multiple-height connections are accomplished by combining standard height panel connectors (35”H, 42”H, 50”H and 65”H) with shorter trim kits (7”H, 15”H, 22”H and 30”H). Start from the top-down — select the standard connector that corresponds to the height and connection type of the tallest panel. (See examples.)

ACCELERATE® PANELS OVERVIEW

Example 1

Connectors required:
1-50"H "T" Connector
2-15"H Connector VH Kit
2-35"H End Trim
1-65"H End Trim

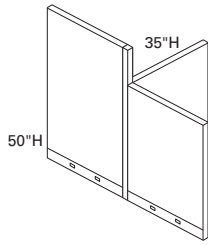

In variable height "T" connections — as shown above — you would use the connectors as indicated.

Example 2

Connectors required:
1-50"H "X" Connector
2-7½"H Connector VH Kit
2-50"H End Trim
2-42"H End Trim

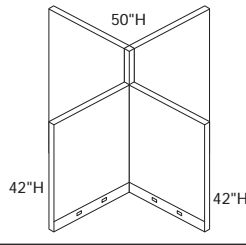

Example 3

Connectors required:
1-65"H "T" Connector
1-15"H Connector VH Kit
1-22½"H Connector VH Kit
1-65"H End Trim
1-50"H End Trim
1-42"H End Trim

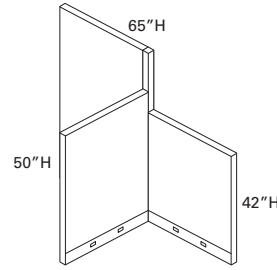

Example above represents Accelerate variable height "L" for 65" to 50".

TOP CAPS

Top caps must be specified as a separate model from the panel. Top caps can span more than one panel when panels are connected in an in-line.

ACCELERATE® WORKING WITH PANELS

PANELS

- Accelerate® Panels are 2½" thick and available in 4 heights / 8 widths.

NOTE: Actual panel height varies depending on position of levelers.

NOMINAL PANEL HEIGHT	PANEL WIDTHS							
	20"	24"	30"	36"	42"	48"	60"	72"
35"	20"	24"	30"	36"	42"	48"	60"	72"
42½"	20"	24"	30"	36"	42"	48"	60"	72"
50"	20"	24"	30"	36"	42"	48"	60"	72"
65"	20"	24"	30"	36"	42"	48"	60"	72"

Maximum Receptacle Capacity in Panel Base Pathways

Widths	20	24	30	36	42	48	60	72
Maximum of 1 duplex per panel side	N/A	X						
Maximum of 2 duplexes per panel side	N/A		X	X	X	X	X	X

The center of the duplex is always 12" from the end of the panel on all Accelerate® panels.

Design:

- Slots allow hanging worksurfaces and hang-on units, in 1" increments.
- Panels standard with two adjustable leveling glides.
- No panel creep.
- Meets or exceeds ANSI/BIFMA Standards.

Top Tier and Stacking Panels

- Available in tackable fabric as well as clear and frosted glass.
- Select from a full height panel/top tier panels or stackers.
- Stackers can be stacked up to 80"H on a base panel.
- Overheads can be placed on the first stacker only, up to 65"H. Voi overheads are not to be placed on stackers.

PANEL SPECIFICATION AND INSTALLATION NOTES

Definitions:

Parent Panel Run – Panels (or a single panel) configured in a straight line intended to divide space. It is usually longer than the panels used to stabilize it.

Return Panels – Panels attached to a parent run for the purpose of stabilizing it. Return panels may also have the effect of dividing space.

Note: Return panels must be no more than 30" lower than the maximum height of the parent panel run. When stacking, the maximum height allowed is 80". This includes frameless glass. If attaching overhead storage, return panels must be the same height as parent run.

Method 1: Opposing Returns

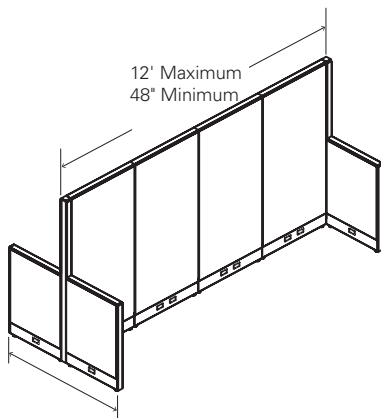

Method 2: Single-Sided

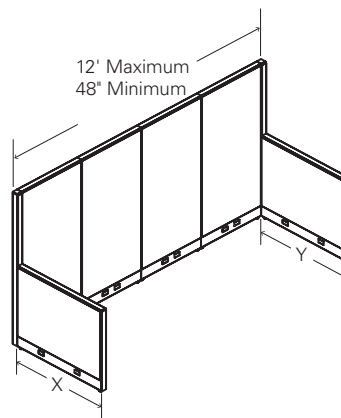

A parent panel run must be a minimum of 4 feet and a maximum of 12 feet, and must have a minimum of two return panels extended in opposing directions on each side of the parent run.

Panel Run Length	Minimum Return Panels	Minimum Return Panels with Stack-ons
48"	20"	20"
54"	20"	20"
60"	20"	20"
66"	20"	20"
72"	20"	20"
78"	20"	20"
84"	20"	20"
90"	20"	20"
96"	20"	20"
102"	20"	20"
108"	24"	24"
114"	24"	24"
120"	24"	24"
144"	24"	24"

A parent panel run must be a minimum of 4 feet and a maximum of 12 feet, and must have a minimum of two return panels (X+Y) extended in one direction (one at the beginning and at the end of the parent run) as defined below.

Panel Run Length	Minimum Return Panels Total (X+Y)	Minimum Return Panels Total (X+Y) with Stack-ons
48"	84"	84"
54"	84"	84"
60"	84"	84"
66"	84"	84"
72"	84"	84"
78"	84"	84"
84"	84"	84"
90"	84"	84"
96"	84"	84"
102"	84"	84"
108"	84"	96"
114"	84"	96"
120"	84"	96"
144"	84"	96"

ACCELERATE® CONNECTOR OVERVIEW

CONNECTOR KITS — ACCELERATE®

TPS	In-line Connector
PS	Extended Straight Connector
PL	“L” Connector
PT	“T” Connector
PX	“X” Connector
P2	120° 2-way Connector
P3	120° 3-way Connector
CV	Connector Variable Height Finishing Kit
VH	In-line Variable Height Finishing Kit

ADDITIONAL MODELS FOR USE WITH CONNECTOR KITS

FE	Finished End Covers
WS	Wall Starter Kit
WT	Wall Track

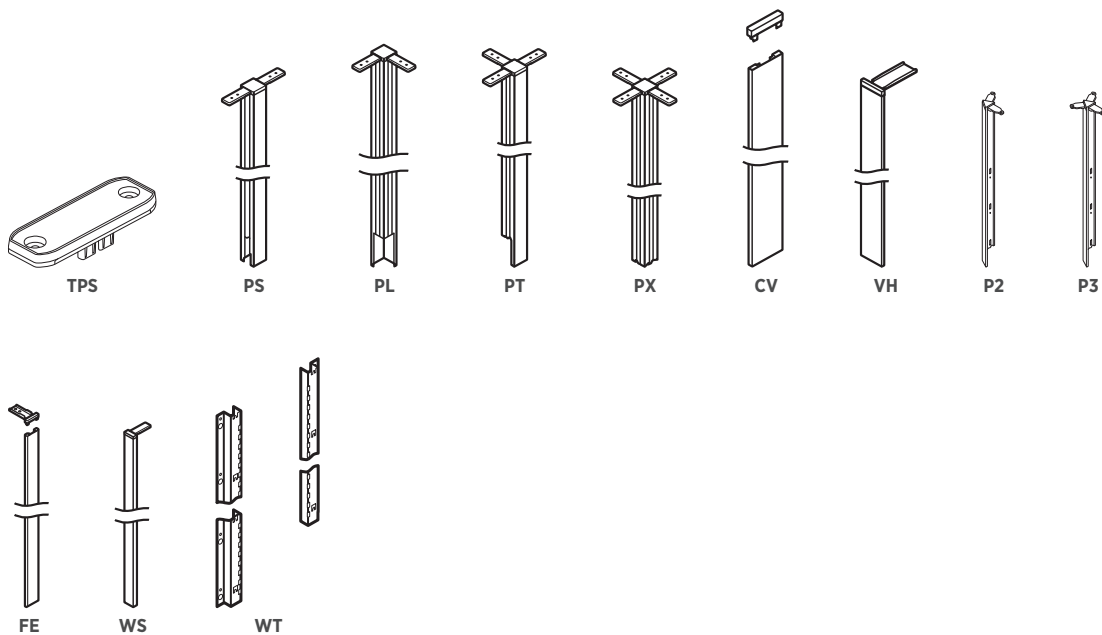

Panel-to-Panel Connector

- Attaches same height, panel-to-panel in a straight run with screws.
- Ensures alignment on panels in a straight run.

Wall Starter Kit (see page 458)

- Anchor devices are not supplied with the wall starter kit. Refer to Accelerate® Installation Instructions for appropriate hardware.
- Adds 7/8" to length of run.

ACCELERATE® Tackable Raceway Panels

GSA SIN 33721



Icon Legend on page 19

WORKSTATIONS

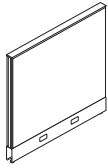

DESCRIPTION

MODEL

SHIP WEIGHT

CUBE

CORE LIST PRICE BY CODE

AA

A

B

35" H Tackable Acoustical Panels

35" H x 20" W	HETP3520FP	13	1.0	\$264	\$275	\$294
35" H x 24" W	HETP3524FP	14	1.2	\$273	\$284	\$326
35" H x 30" W	HETP3530FP	16	1.5	\$285	\$298	\$343
35" H x 36" W	HETP3536FP	18	1.8	\$306	\$320	\$367
35" H x 42" W	HETP3542FP	20	2.1	\$310	\$325	\$378
35" H x 48" W	HETP3548FP	23	2.4	\$328	\$344	\$399
35" H x 60" W	HETP3560FP	27	3.0	\$356	\$374	\$439
35" H x 72" W*	HETP3572FP	33	3.6	\$499	\$518	\$591

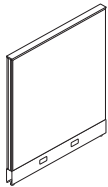

42 1/2" H Tackable Acoustical Panels

42 1/2" H x 20" W	HETP4220FP	14	1.2	\$277	\$290	\$322
42 1/2" H x 24" W	HETP4224FP	16	1.5	\$290	\$303	\$335
42 1/2" H x 30" W	HETP4230FP	18	1.8	\$306	\$318	\$357
42 1/2" H x 36" W	HETP4236FP	20	2.2	\$323	\$337	\$379
42 1/2" H x 42" W	HETP4242FP	23	2.6	\$351	\$367	\$416
42 1/2" H x 48" W	HETP4248FP	25	3.0	\$364	\$382	\$441
42 1/2" H x 60" W	HETP4260FP	30	3.7	\$406	\$425	\$494
42 1/2" H x 72" W*	HETP4272FP	36	4.4	\$524	\$546	\$625

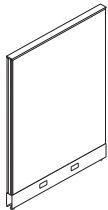

50" H Tackable Acoustical Panels

50" H x 20" W	HETP5020FP	16	1.4	\$318	\$333	\$396
50" H x 24" W	HETP5024FP	17	1.7	\$331	\$346	\$409
50" H x 30" W	HETP5030FP	20	2.2	\$340	\$356	\$400
50" H x 36" W	HETP5036FP	22	2.6	\$350	\$366	\$416
50" H x 42" W	HETP5042FP	25	3.0	\$393	\$411	\$469
50" H x 48" W	HETP5048FP	28	3.5	\$414	\$434	\$499
50" H x 60" W	HETP5060FP	32	4.3	\$453	\$474	\$548
50" H x 72" W*	HETP5072FP	38	5.2	\$572	\$595	\$681

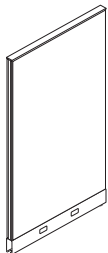

65" H Tackable Acoustical Panels

65" H x 20" W	HETP6520FP	19	1.9	\$338	\$353	\$401
65" H x 24" W	HETP6524FP	20	2.3	\$351	\$366	\$414
65" H x 30" W	HETP6530FP	23	2.8	\$370	\$386	\$437
65" H x 36" W	HETP6536FP	26	3.4	\$396	\$414	\$472
65" H x 42" W	HETP6542FP	29	3.9	\$432	\$451	\$516
65" H x 48" W	HETP6548FP	32	4.5	\$450	\$470	\$543
65" H x 60" W	HETP6560FP	37	5.6	\$480	\$500	\$582
65" H x 72" W*	HETP6572FP	43	6.8	\$650	\$673	\$765

NOTES:

- Panels are 2 1/8" thick.
- Baseraills ship standard with panels.
- Top caps ordered separately; see page 453.
- Packaging: stretch wrapped with edge protection.
- Base rail matches trim color.
- For worksurfaces that can be used with Abound® and Accelerate® systems, see pages 568-578.
- Panel end trim ordered separately; see page 458.
- Panels may be connected end to end, with wall starter kit, or with panel connectors; see pages 457-458.
- Order Accelerate® connectors separately; see page 457.
- Panels have a class A fire rating.
- Bulk packing is available in quantities of 3 or 9.

- Fabrics and finishes available on pages 441, 442-443.

- Panel stability will be increased by tying panels to worksurfaces or storage.

Raceway panels option only.

Do not remove electrical knockouts unless duplex is needed. For replacement covers, see page 560.

Accepts electrical power kits, except for 20" W. See page 558 for electrical.

Stack on panels add 15" of height and can be added to any monolithic panel. See stackers on pages 454-455.

Disperse and Analog fabrics are not available on 72" W panels.

If adding to existing panels produced prior to 04/13/16, please contact Customer Support for compatibility.

If a third cutout for data is desired, order the separate kickplate model HEBPLATE.

HOW TO SPECIFY

Select Model Number

HETP3520FP

Select Fabric

See pages 442-443

APN15

Select Trim Color

See page 441

P1 Paint (no upcharge)
P2 Paint (\$30 upcharge)

S



Icon Legend on page 19

ACCELERATE® Top-Tier Glass Panels

WORKSTATIONS

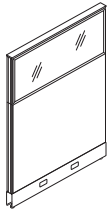

DESCRIPTION

50''H Tackable Panels — Top-Tier Glass

- 50''H x 20''W
- 50''H x 24''W
- 50''H x 30''W
- 50''H x 36''W
- 50''H x 42''W
- 50''H x 48''W
- 50''H x 60''W
- 50''H x 72''W*

MODEL	SHIP WEIGHT	CUBE	CORE LIST PRICE BY CODE		
			AA	A	B
HETP5020DP	21 Ⓢ	1.4	\$500	\$520	\$583
HETP5024DP	23 Ⓢ	1.7	\$519	\$539	\$602
HETP5030DP	27 Ⓢ	2.2	\$531	\$553	\$597
HETP5036DP	31 Ⓢ	2.6	\$541	\$563	\$613
HETP5042DP	34 Ⓢ	3.0	\$592	\$616	\$674
HETP5048DP	39 Ⓢ	3.5	\$617	\$644	\$709
HETP5060DP	46	4.3	\$666	\$696	\$771
HETP5072DP	55	5.2	\$888	\$921	\$1006

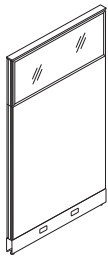

65''H Tackable Panels — Top-Tier Glass

- 65''H x 20''W
- 65''H x 24''W
- 65''H x 30''W
- 65''H x 36''W
- 65''H x 42''W
- 65''H x 48''W
- 65''H x 60''W
- 65''H x 72''W*

HETP6520DP	24 Ⓢ	1.9	\$523	\$544	\$592
HETP6524DP	27 Ⓢ	2.3	\$539	\$560	\$608
HETP6530DP	30 Ⓢ	2.8	\$557	\$579	\$630
HETP6536DP	34 Ⓢ	3.4	\$588	\$612	\$670
HETP6542DP	39 Ⓢ	3.9	\$631	\$657	\$722
HETP6548DP	43 Ⓢ	4.5	\$653	\$680	\$753
HETP6560DP	51	5.6	\$681	\$711	\$795
HETP6572DP	60	6.8	\$970	\$1003	\$1095

NOTES:

- On top-tier panel models, the glass tier is 15''H.
- Glass is clear or frosted, tempered safety glass.
- Panels are 2 1/8'' thick.
- Panels have steel baserails.
- Packaging: stretch wrapped with edge protection.
- Base rail matches trim color.
- Top caps ordered separately; see page 453.
- For worksurfaces that can be used with Abound® and Accelerate® systems, see pages 568-578.
- Panel end trim ordered separately; see page 458.
- Panels may be connected end to end, with wall starter kit, or with panel connectors; see pages 457-458.
- Order Accelerate® connectors separately; see page 457.
- Panels have a class A fire rating.
- Bulk packing is available in quantities of 3 or 9.
- Fabrics and finishes available on pages 441, 442-443.
- Panel stability will be increased by tying panels to worksurfaces or storage.
- ⓘ Raceway panels option only.
- ⓘ Do not remove electrical knockouts unless duplex is needed. For replacement covers, see page 560.
- ⓘ Accepts electrical power kits, except for 20''W. See page 558 for electrical.
- ⓘ Cannot stack stacker on top-tier glass panels.
- ⓘ Disperse and Analog fabrics are not available on 72''W panels.
- ⓘ If adding to existing panels produced prior to 04/13/16, please contact Customer Support for compatibility.
- ⓘ If a third cutout for data is desired, order the separate kickplate model HEBPLATE.

HOW TO SPECIFY

<p>Select Model Number</p> <p>HETP5020DP</p>	<p>Select Fabric</p> <p>See pages 442-443</p> <p>APN15</p>	<p>Select Trim Color</p> <p>See page 441</p> <p>P1 Paint (no upcharge)</p> <p>P2 Paint (\$30 upcharge)</p> <p>S</p>	<p>Select Glass</p> <p>Q Clear Glass</p> <p>R Frosted Glass (\$30 upcharge)</p> <p>Q</p>
---	---	--	---

ACCELERATE® Panel Door

GSA SIN 33721



Icon Legend on page 19

WORKSTATIONS

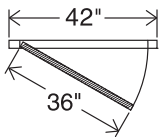
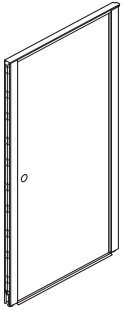

DESCRIPTION	MODEL	SHIP WEIGHT	CUBE	LIST PRICE BY PAINT GRADE	
				P1	P2

Door Panel — Laminate 42"W x 80"H	HEPDMK42P	155.0	7.3	\$1890	\$1920
---	------------------	-------	-----	---------------	---------------

NOTES: Ships with door, frame, hinges and hardware. Best placement of a door is at an L, T, X connector or wall starter connector for rigidity. Use of spanning top caps at an in-line will also help add additional rigidity.

❗ Must be used with a base panel and stacker equaling 80"H.

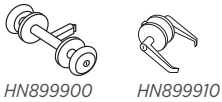

HN899900 HN899910

Standard Lock Set

Door knob (polished brass)	HN899900	2.0 Ⓢ	0.1	\$117	
Door lever (brushed aluminum)	HN899910	2.0 Ⓢ	0.1	\$324	

NOTES: Door knob and lever are both keyed on one side.



Abound® and Accelerate® Sliding Door

50"H x 42"W	HH15042SD	28.0	5.5	\$2038	\$2074
65"H x 42"W	HH16542SD	38.0	7.1	\$2324	\$2360
80"H x 42"W	HH18042SD	46.0	8.6	\$2843	\$2879

❗ Door is only available in Frosted Translucent Acrylic. Specify paint for frame.

❗ Can only install Sliding Door at the end of a run, not at a corner.

❗ A Mounting Bracket Kit must be ordered for each sliding door corresponding to the mounting panels width (30", 36", 42", or 48"W).

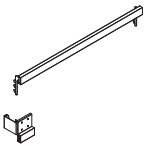

Accelerate® Mounting Kit for Sliding Door

For 30"W Panel	HESDMK30	4.0	0.4	\$168	\$180
For 36"W Panel	HESDMK36	5.0	0.5	\$176	\$188
For 42"W Panel	HESDMK42	6.0	0.5	\$184	\$196
For 48"W Panel	HESDMK48	7.0	0.5	\$192	\$204

NOTES: Specify paint.



Carpet Grippers

	HICG12	0.5 Ⓢ	0.1	\$20	
--	---------------	-------	-----	-------------	--

NOTES: Used with Glide Towers
Shipped 12 per package
No need to specify paint



Coat Hooks

Package of six	HHPMC6	1.0 Ⓢ	0.2	\$87	
----------------	---------------	-------	-----	-------------	--

NOTES: Compatible with Accelerate® and Abound® panels.

❗ Black only.

NOTES:

- Order handle separately. See handle model options above.
- Specify top caps separately when ordering the laminate panel door; see page 453.
- Order Accelerate® connectors separately; see page 457.
- Fabrics and finishes available on pages 441, 442-443.
- The Sliding Doors are available in 50", 65", and 80"H models and can mount to 30", 36", 42", and 48"W panels.
- All doors are 42" wide, provide a 36"W opening, and are non-handed.

HOW TO SPECIFY

Select Model Number

H E P D M K 4 2 P .

Select Trim Color

See page 441

T 4 .

Select Door Laminate

L2 Laminate Upcharge \$60
See page 441

H



Icon Legend on page 19

ACCELERATE® Top Caps

DESCRIPTION	MODEL	SHIP WEIGHT	CUBE	LIST PRICE BY PAINT GRADE	
				P1	P2
Panel Top Cap					
20"W	HETC20	1.5	0.3	\$36	\$56
24"W	HETC24	1.6	0.3	\$36	\$56
30"W	HETC30	1.8	0.3	\$44	\$64
36"W	HETC36	2.0	0.3	\$56	\$76
42"W	HETC42	2.2	0.3	\$59	\$79
48"W	HETC48	3.4	0.4	\$66	\$86
60"W	HETC60	3.9	0.6	\$81	\$101
66"W	HETC66	4.0	0.6	\$96	\$116
72"W	HETC72	5.3	0.8	\$100	\$120
78"W	HETC78	6.5	0.8	\$103	\$123
84"W	HETC84	6.7	0.9	\$115	\$135
90"W	HETC90	7.0	0.9	\$121	\$141
96"W	HETC96	7.2	0.9	\$127	\$147

NOTES:

- Models above are specified for panel models on pages 450-451.
 - Top caps ship separately from panels.
 - Top caps are able to span multiple panels for a clean aesthetic.
 - Top caps are bulk packed for ease at installation sites.
- ❗ If adding to existing panels produced prior to 04/13/16, please contact Customer Support for compatibility.

HOW TO SPECIFY

Select Model Number	Select Paint Color
HE TC 20 .	T 3

DESCRIPTION	MODEL	SHIP WEIGHT	CUBE	LIST PRICE BY PAINT GRADE	
				P1	P2
Accelerate® Base Pathway Cover w/Additional Knockout					
36"W	HEBPLATE336	7 Ⓞ	0.4	\$72	\$82
42"W	HEBPLATE342	8 Ⓞ	0.4	\$74	\$84
48"W	HEBPLATE348	9 Ⓞ	0.4	\$77	\$87
60"W	HEBPLATE360	11 Ⓞ	0.5	\$88	\$98
72"W	HEBPLATE372	14 Ⓞ	0.6	\$98	\$108

NOTES: Specify paint, see page 441.
SPECIFYING EXAMPLE: HEBPLATE336.T4

NOTES:

- ❗ Specify Pathways to match trim color.
- ❗ Standard raceways with two knockouts are standard on panels. If additional three knockout kickplate is ordered, the two port version can be saved or discarded.

HOW TO SPECIFY

Select Model Number	Select Paint Color
HE B P L A T E 3 3 6 .	T 4

ACCELERATE® Stacking Panels

GSA SIN 33721



Icon Legend on page 19

WORKSTATIONS



DESCRIPTION	MODEL	SHIP WEIGHT	CUBE	CORE LIST PRICE BY CODE		
				AA	A	B
15”H Stacking Panels — Fabric						
15”H x 20”W	HES1520F	6	0.5	\$180	\$201	\$249
15”H x 24”W	HES1524F	7	0.6	\$199	\$220	\$268
15”H x 30”W	HES1530F	8	0.8	\$215	\$237	\$288
15”H x 36”W	HES1536F	9	0.9	\$231	\$255	\$313
15”H x 42”W	HES1542F	11	1.1	\$249	\$275	\$340
15”H x 48”W	HES1548F	12	1.2	\$265	\$292	\$365
15”H x 60”W	HES1560F	14	1.5	\$299	\$329	\$413
15”H x 72”W	HES1572F	17	1.8	\$568	\$601	\$693

NOTES:

- Stacking panels ship without top caps.
- Stackers add 15” or 30” to the height of the base panel.
- Stacker ships with pins to connect stacker to post connector for added rigidity.
- Select complete panels with top-tier glass, or add glass/fabric stackers separately to existing panels. See page 451 for complete panels information.
- Not to be used freestanding.
- Stackers can be stacked up to 80”H on a base panel or 30” of stacker height total, whichever comes first.
- The first stacker on a base panel is weight bearing and can accommodate overhead storage up to 65”H.
- Stacking model must match the width of the panel it is stacking on.
- Total panel height cannot exceed 80” high. Glass stacker must be the top tier. A stacking panel cannot be placed above a glass panel or glass stacker. Frameless Glass can be installed on a fabric stacker.
- Voi overheads not to be placed on stackers.
- If adding to existing panels produced prior to 04/13/16, please contact Customer Support for compatibility.

HOW TO SPECIFY

<p>Select Model Number</p> <p>HES1520F.</p>	<p>Select Fabric Color</p> <p>See pages 442-443</p> <p>APN11</p>
---	--



ACCELERATE® Stacking Panels

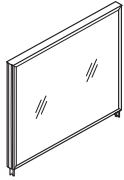

DESCRIPTION

30”H Stacking Panels — Glass

- 30”H x 20”W
- 30”H x 24”W
- 30”H x 30”W
- 30”H x 36”W
- 30”H x 42”W
- 30”H x 48”W
- 30”H x 60”W

MODEL	SHIP WEIGHT	CUBE	CLEAR GLASS	FROSTED GLASS
HES3020G	14 Ⓢ	1.0	\$588	\$618
HES3024G	17 Ⓢ	1.2	\$618	\$648
HES3030G	20 Ⓢ	1.5	\$701	\$731
HES3036G	23 Ⓢ	1.8	\$724	\$754
HES3042G	26 Ⓢ	2.1	\$802	\$832
HES3048G	29 Ⓢ	2.4	\$865	\$895
HES3060G	36	3.0	\$991	\$1021

NOTES: 30”H stacker ships with pins to connect stacker to post connector for added rigidity.

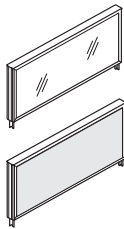

15”H Stacking Panels — Glass

- 15”H x 20”W
- 15”H x 24”W
- 15”H x 30”W
- 15”H x 36”W
- 15”H x 42”W
- 15”H x 48”W
- 15”H x 60”W
- 15”H x 72”W

HES1520G	8 Ⓢ	0.5	\$393	\$423
HES1524G	9 Ⓢ	0.6	\$414	\$444
HES1530G	11 Ⓢ	0.8	\$468	\$498
HES1536G	12 Ⓢ	0.9	\$485	\$515
HES1542G	14 Ⓢ	1.1	\$536	\$566
HES1548G	16 Ⓢ	1.2	\$577	\$607
HES1560G	19 Ⓢ	1.5	\$660	\$690
HES1572G	22	1.8	\$803	\$833

NOTES:

- Stacking panels ship without top caps.
- Stackers add 15” or 30” to the height of the base panel.
- Stacker ships with pins to connect stacker to post connector for added rigidity.
- Select complete panels with top-tier glass, or add glass/fabric stackers separately to existing panels. See page 451 for complete panels information.
- ❗ Not to be used freestanding.
- ❗ Stackers can be stacked up to 80”H on a base panel or 30” of stacker height total, whichever comes first.
- ❗ The first stacker on a base panel is weight bearing and can accommodate overhead storage up to 65”H.
- ❗ Stacking model must match the width of the panel it is stacking on.
- ❗ Total panel height cannot exceed 80” high. Glass stacker must be the top tier. A stacking panel cannot be placed above a glass panel or glass stacker. Frameless Glass can be installed on a fabric stacker.
- ❗ If adding to existing panels produced prior to 04/13/16, please contact Customer Support for compatibility.

HOW TO SPECIFY

<p>Select Model Number</p> <p>HES3020G</p>	<p>Select Paint Color</p> <p>See page 441 P1 Paint (no upcharge) P2 Paint (\$30 upcharge)</p> <p>T1</p>	<p>Select Glass</p> <p>Q Clear Glass R Frosted Glass</p> <p>Q</p>
---	--	---

ACCELERATE® Frameless Glass

GSA SIN 33721



Icon Legend on page 19

WORKSTATIONS

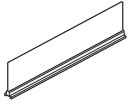

DESCRIPTION

7 1/2" H Frameless Glass

7 1/2" H x 20" W
7 1/2" H x 24" W
7 1/2" H x 30" W
7 1/2" H x 36" W
7 1/2" H x 42" W
7 1/2" H x 48" W
7 1/2" H x 54" W
7 1/2" H x 60" W
7 1/2" H x 66" W
7 1/2" H x 72" W

MODEL	SHIP WEIGHT	CUBE	CLEAR GLASS	FROSTED GLASS
HEFG0720	17	0.4	\$308	\$338
HEFG0724	18	0.5	\$364	\$401
HEFG0730	18	0.5	\$393	\$434
HEFG0736	21	0.6	\$451	\$498
HEFG0742	25	0.7	\$481	\$531
HEFG0748	28	0.8	\$517	\$571
HEFG0754	28	0.8	\$583	\$644
HEFG0760	35	1.0	\$634	\$700
HEFG0766	35	1.0	\$707	\$779
HEFG0772	42	1.9	\$749	\$827

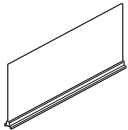

15" H Frameless Glass

15" H x 20" W
15" H x 24" W
15" H x 30" W
15" H x 36" W
15" H x 42" W
15" H x 48" W
15" H x 54" W
15" H x 60" W
15" H x 66" W
15" H x 72" W

HEFG1520	27	1.3	\$382	\$412
HEFG1524	28	1.5	\$413	\$450
HEFG1530	28	1.5	\$442	\$483
HEFG1536	34	1.8	\$507	\$554
HEFG1542	39	2.0	\$545	\$595
HEFG1548	45	2.3	\$588	\$642
HEFG1554	51	2.6	\$644	\$705
HEFG1560	57	2.8	\$718	\$784
HEFG1566	62	3.2	\$783	\$855
HEFG1572	67	3.5	\$846	\$924

NOTES:

- Glass is a single-pane, 3/8" laminated safety glass.
- Available in clear or frosted glass.
- Frameless Glass can span multiple panels with one piece of glass.
- Lamination is in the center of the glass, making both clear and frosted glass a writable surface with dry-erase markers.
- ⚠ Glass tiles have a Class A fire rating.
- ⚠ Frameless Glass can only be used on the tallest panel of the typical. Please see published Tailored Solutions models on honready.com for variable height applications.
- ⚠ Frameless Glass cannot be used on top of glass stackers or headers.
- ⚠ Frameless Glass can only be used on the top of panels. Glass integrates into top cap trim. Do not order a separate top cap model for your frame when using Frameless Glass.
- ⚠ Cannot hang or stack on top of Frameless Glass.
- ⚠ If adding to existing panels produced prior to 04/13/16, please contact Customer Support for compatibility.

HOW TO SPECIFY

Select Model Number

HEFG1520

Select Paint Color

See page 441
P1 Paint (no upcharge)
P2 Paint (\$30 upcharge)

T1

Select Glass Option

Q Clear Glass
R Frosted Glass

Q



	DESCRIPTION	MODEL	SHIP WEIGHT	CUBE	LIST PRICE BY PAINT GRADE	
					P1	P2
	120° 2-way Connector					
	For 35"H Panels	HEC35P2 Ⓢ	6.0	0.4	\$106	\$115
	For 42½"H Panels	HEC42P2 Ⓢ	6.0	0.5	\$123	\$132
	For 50"H Panels	HEC50P2 Ⓢ	7.0	0.6	\$141	\$150
	For 57½"H Panels	HEC57P2 Ⓢ	8.0	0.6	\$149	\$158
	For 65"H Panels	HEC65P2 Ⓢ	8.0	0.7	\$155	\$164
	For 72½"H Panels	HEC72P2 Ⓢ	9.0	0.8	\$163	\$172
For 80"H Panels	HEC80P2 Ⓢ	9.0	0.9	\$170	\$179	
	120° 3-way Connector					
	For 35"H Panels	HEC35P3 Ⓢ	6.0	0.4	\$106	\$115
	For 42½"H Panels	HEC42P3 Ⓢ	6.0	0.5	\$123	\$132
	For 50"H Panels	HEC50P3 Ⓢ	7.0	0.6	\$141	\$150
	For 57½"H Panels	HEC57P3 Ⓢ	8.0	0.6	\$149	\$158
	For 65"H Panels	HEC65P3 Ⓢ	8.0	0.7	\$155	\$164
	For 72½"H Panels	HEC72P3 Ⓢ	9.0	0.8	\$163	\$172
For 80"H Panels	HEC80P3 Ⓢ	9.0	0.9	\$170	\$179	
	In-line Connector	HSCKTPS	0.5	0.1	\$19	N/A
	NOTES: No need to specify finish. SPECIFYING EXAMPLE: HSCKTPS.X					
	Extended Straight Connector					
	For 35"H Panels	HEC35PS Ⓢ	6.0 Ⓢ	0.4	\$106	\$115
	For 42½"H Panels	HEC42PS Ⓢ	6.0 Ⓢ	0.5	\$123	\$132
	For 50"H Panels	HEC50PS Ⓢ	7.0 Ⓢ	0.6	\$141	\$150
	For 57"H Panels	HEC57PS Ⓢ	8.0 Ⓢ	0.6	\$149	\$158
	For 65"H Panels	HEC65PS Ⓢ	8.0 Ⓢ	0.7	\$155	\$164
	For 72½"H Panels	HEC72PS Ⓢ	9.0	0.8	\$165	\$174
For 80"H Panels	HEC80PS Ⓢ	9.0	0.9	\$170	\$179	
	"L" Connector					
	For 35"H Panels	HEC35PL Ⓢ	6.0 Ⓢ	0.4	\$106	\$115
	For 42½"H Panels	HEC42PL Ⓢ	6.0 Ⓢ	0.5	\$123	\$132
	For 50"H Panels	HEC50PL Ⓢ	7.0 Ⓢ	0.6	\$141	\$150
	For 57"H Panels	HEC57PL Ⓢ	8.0 Ⓢ	0.6	\$149	\$158
	For 65"H Panels	HEC65PL Ⓢ	8.0 Ⓢ	0.7	\$155	\$164
	For 72½"H Panels	HEC72PL Ⓢ	9.0	0.8	\$165	\$174
For 80"H Panels	HEC80PL Ⓢ	9.0	0.9	\$170	\$179	
	"T" Connector					
	For 35"H Panels	HEC35PT Ⓢ	6.0 Ⓢ	0.4	\$106	\$115
	For 42½"H Panels	HEC42PT Ⓢ	6.0 Ⓢ	0.5	\$123	\$132
	For 50"H Panels	HEC50PT Ⓢ	7.0 Ⓢ	0.6	\$141	\$150
	For 57"H Panels	HEC57PT Ⓢ	8.0 Ⓢ	0.6	\$149	\$158
	For 65"H Panels	HEC65PT Ⓢ	8.0 Ⓢ	0.7	\$155	\$164
	For 72½"H Panels	HEC72PT Ⓢ	9.0	0.8	\$165	\$174
For 80"H Panels	HEC80PT Ⓢ	9.0	0.9	\$170	\$179	
	"X" Connector					
	For 35"H Panels	HEC35PX Ⓢ	6.0 Ⓢ	0.4	\$106	\$115
	For 42½"H Panels	HEC42PX Ⓢ	6.0 Ⓢ	0.5	\$123	\$132
	For 50"H Panels	HEC50PX Ⓢ	7.0 Ⓢ	0.6	\$141	\$150
	For 57"H Panels	HEC57PX Ⓢ	8.0 Ⓢ	0.6	\$149	\$158
	For 65"H Panels	HEC65PX Ⓢ	8.0 Ⓢ	0.7	\$155	\$164
	For 72½"H Panels	HEC72PX Ⓢ	9.0	0.8	\$165	\$174
For 80"H Panels	HEC80PX Ⓢ	9.0	0.9	\$170	\$179	

NOTES:

- Specify connectors based on number and placement of panels.
- Connectors ship complete with all hardware necessary to complete connection.
- Specify connector to fit height of tallest panel.
- Connectors are made of extruded aluminum.
- Straight Connector model HSCKTPS ships standard in bulk pack.

• All connectors (except 120° models) are adaptable with power pole for ceiling in feeds; see page 560.

- ⓘ In-line connector must be specified for all in-line connections.
- ⓘ If adding to existing panels produced prior to 04/13/16, please contact Customer Support for compatibility.

! New Strengthened Connections available 10/1/2020.

Ⓢ Discontinued 12/31/20.

HOW TO SPECIFY

<p>Select Model Number</p> <p>H E C 3 5 P 2</p>	<p>Select Paint Color</p> <p>See page 441</p> <p>T 3</p>
--	---



DESCRIPTION	MODEL	SHIP WEIGHT	CUBE	LIST PRICE BY PAINT GRADE	
				P1	P2
Finished End Covers					
35"H	HEFEC35P	3 Ⓢ	0.4	\$49	\$58
42½"H	HEFEC42P	3 Ⓢ	0.5	\$52	\$61
50"H	HEFEC50P	4 Ⓢ	0.6	\$56	\$65
57½"H	HEFEC57P	5 Ⓢ	0.6	\$59	\$68
65"H	HEFEC65P	5 Ⓢ	0.7	\$63	\$72
72½"H	HEFEC72P	6 Ⓢ	0.8	\$67	\$76
80"H	HEFEC80P	6 Ⓢ	0.9	\$70	\$79

NOTES: Finished End Covers include top bracket, end trim clips and end trim.



In-line Variable Height Finishing Kit					
7½"H	HEVHF07P	2 Ⓢ	0.2	\$51	\$60
15"H	HEVHF15P	2 Ⓢ	0.4	\$55	\$64
22½"H	HEVHF22P	3 Ⓢ	0.4	\$65	\$74
30"H	HEVHF30P	3 Ⓢ	0.4	\$76	\$85

NOTES: In-line Variable Height Finishing Kits include top and bottom bracket, end trim clips and end trim. In-line Variable Height Finishing Kit is used to connect a finished in-line panel connection.



Connector Variable Height Finishing Kit					
7½"H	HECVH07P	2 Ⓢ	0.2	\$51	\$60
15"H	HECVH15P	2 Ⓢ	0.4	\$55	\$64
22½"H	HECVH22P	3 Ⓢ	0.4	\$65	\$74
30"H	HECVH30P	3 Ⓢ	0.4	\$76	\$85

NOTES: Connector Variable Height Finishing Kits include top and bottom bracket, end trim and end trim connection piece.



Wall Starter Kit					
35"H	HEWS35P	4 Ⓢ	0.4	\$83	\$92
42½"H	HEWS42P	4 Ⓢ	0.5	\$88	\$97
50"H	HEWS50P	5 Ⓢ	0.6	\$92	\$101
57½"H	HEWS57P	6 Ⓢ	0.6	\$97	\$106
65"H	HEWS65P	6 Ⓢ	0.7	\$103	\$112
72½"H	HEWS72P	7 Ⓢ	0.8	\$112	\$121
80"H	HEWS80P	7 Ⓢ	0.9	\$118	\$127



Permanent Wall Hanger Kit					
2½"W x 7⁄8"D x 66"H	HRVC35PCE	6 Ⓢ	0.7	\$218	\$238
4¼"W x 7⁄8"D x 66"H	HRVC35PCM	3 Ⓢ	0.7	\$114	\$124

ⓘ Anchor devices are not supplied with this model. Refer to Abound® Installation instructions for appropriate hardware. Attachment to masonry walls is not recommended.

Specify paint

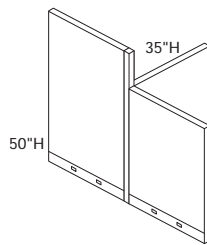

T-Connection
Connector, Variable Height Finishing Kit

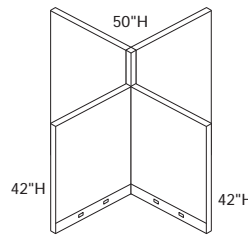

X-Connection
Connector, Variable Height Finishing Kit

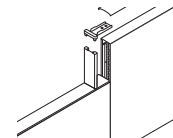

In-line Variable Height Trim Kit

NOTES:

- In-line Variable Height Finishing Kit is used to connect a finished in-line panel connection.
- Connector variable height finishing kit is used at a drop in height at an L, T, X, or S connection.
- All kits come with all hardware needed to install the kit.

- ⓘ Variable height kit needs to be specified any time a change of panel height occurs.
- ⓘ Finished end covers must be specified at all end of panel runs.
- ⓘ If adding to existing panels produced prior to 04/13/16, please contact Customer Support for compatibility.

HOW TO SPECIFY

<p>Select Model Number</p> <p>HEFEC35P</p>	<p>Select Paint Color</p> <p>See page 441</p> <p>T3</p>
--	---



ACCELERATE® Bracket Kits and Stability Feet



DESCRIPTION

Accelerate® Anchor Bracket

Package of ten

NOTES: For use when panels need to be anchored to the floor such as high traffic areas or community spaces.

⚠ Only available in Black (P).

SPECIFYING EXAMPLE: HEABAC.P

MODEL

SHIP WEIGHT

CUBE

LIST PRICE

HEABAC

5 Ⓞ

0.08

\$85

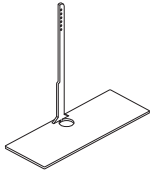

DESCRIPTION

Accelerate® Stability Foot

NOTES: Stabilizes bottom of panel from movement. Will not prohibit movement at top of panel.

MODEL

SHIP WEIGHT

CUBE

LIST PRICE BY PAINT GRADE

P1

P2

HEFTAC

3

0.1

\$374

\$384

NOTES:

- ⚠ The Anchor Bracket and Stability Foot are not intended to create a freestanding panel. Please follow Accelerate® stability standards.
- ⚠ Attachment hardware for floor anchor not included.

HOW TO SPECIFY

Select Model Number

Select Paint Color

See page 441

H E F T A C .

T 1

NOTES

WORKSTATIONS

EMPOWER®



Empower 2- and 4-Pack Benching Systems with Ignition® Seating, Voi® and Contain® Storage and Arrange® Tables.

EMPOWER®

Need a simple way to get up and running fast? No problem. Looking to expand and customize workstations for a growing business? Empower does that, too. With Empower benching, you've got the power to do more. Offer more personal space. Enjoy more adaptability. Route power more efficiently. It's simple to order, easy to install and quick to reconfigure. When you Empower your people, you keep pace with the changing demands of today's workplace.



FEATURES

- With numerous laminate selections to choose from, it's easy to get the exact look you want.
- Integrated height adjustability supports the work style of any user.
- Frosted glass. Colorful fabrics. Magnetic metal. Empower screens add style, privacy and functionality.
- Choose from multiple paint finishes to blend in or stand out.
- As the main electrical artery, power and data cables are laid into the trough.
- Plug power modules into the duplex in the trough and attach them to the worksurface for easy access to electrical and USB ports.
- Power entry can be accommodated through the ceiling, floor, or wall.
- Keep cords collected and controlled from floor to wire trough with vertebra.
- Support any work style by adding HON pedestals, credenzas and storage towers to Empower benching.

EMPOWER[®] FABRIC SCREENS — ALL PANEL MODELS

PRICE CODE AA

FACTOR	FACT
◆ Bark	FACT20
◆ Barley	FACT15
◆ Cascade	FACT25
◆ Feather	FACT30

PRICE CODE A

APPOINT	APN
◆ Artichoke	APN11
◆ Blackberry	APN32
◆ Bronze	APN22
◆ Carbon	APN28
◆ Chai	APN12
◆ Cherry	APN30
◆ Dark Pewter	APN17
◆ Dune	APN15
◆ Espresso	APN23
◆ Framboise	APN31
◆ Frost	APN34
◆ Jet	APN27
◆ Lawn	APN25
◆ Mandarin	APN29
◆ Morel	APN09
◆ Nimbus	APN16
◆ Platinum	APN24
◆ Turquoise	APN26

CENTURION CU

◆ Apricot	CU47
◆ Bark	CU25
◆ Black	CU10
◆ Espresso	CU49
◆ Fog	CU03
◆ Frost	CU22
◆ Goldenrod	CU27
◆ Indigo	CU06
◆ Iris	CU50
◆ Iron Ore	CU19
◆ Jade	CU83
◆ Marsala	CU63
◆ Morel	CU24
◆ Navy	CU98
◆ Peacock	CU97
◆ Pear	CU84
◆ Ruby	CU67
◆ Sapphire	CU09

PRICE CODE A *continued*

ETCH*	ECH
◆ Axis	ECH13
◆ Blend	ECH14
◆ Cast	ECH12
◆ Highlight	ECH10
◆ Midtone	ECH11
◆ Outline	ECH08
◆ Shade	ECH09
◆ Tonal	ECH16
◆ Vanish	ECH15

EXCHANGE* EXG

◆ Iron	EXG916
◆ Nickel	EXG914
◆ Pistachio	EXG910
◆ Root	EXG913
◆ Rupee	EXG903
◆ Shadow	EXG911
◆ Silver	EXG915
◆ Sisal	EXG917
◆ Stone	EXG912

LANDSCAPE* LN

◆ Azure	LN55
◆ Cornsilk	LN15
◆ Drift	LN05
◆ Khaki	LN20
◆ Sheen	LN10
◆ Slate	LN35
◆ Umber	LN25
◆ Urban	LN30

LUCY* LC

◆ Aspen	LC32
◆ Cornsilk	LC30
◆ Dusk	LC22
◆ Fawn	LC33
◆ Graphite	LC34
◆ Mist	LC20
◆ Neutra	LC24
◆ Pewter	LC35
◆ Snowdrop	LC28

PRICE CODE A *continued*

REFLECTIONS*	REF
◆ Galvanized	REF29
◆ Ice	REF20
◆ Loggia	REF21
◆ Mistral	REF28
◆ Moonstone	REF23
◆ Pewter	REF22
◆ Stainless	REF24
◆ Vanilla	REF25
◆ Winter	REF27

REFUGE* RFG

◆ Artesian	RFG96
◆ Dune	RFG92
◆ Eclipse	RFG90
◆ Frost	RFG93
◆ Glacier	RFG91
◆ Mineral	RFG98
◆ Tidal	RFG94

SARTO* SRT

◆ Ash	SRT88
◆ Fog	SRT14
◆ Lemongrass	SRT49
◆ Mist	SRT45
◆ Mushroom	SRT76
◆ Oyster	SRT18
◆ Reef	SRT64
◆ Sesame	SRT93
◆ Shale	SRT52

TEMPEST* TP

◆ Dragonfly	TP30
◆ Frost	TP15
◆ Full Stream	TP80
◆ Gold Rush	TP10
◆ Slate	TP45
◆ Tumbleweed	TP70
◆ Wind Chill	TP40
◆ Zebra	TP35

NOTES: Analog, Disperse, and Exchange panel fabrics will be applied pattern cut. Disperse will not be available on 72"W panels.

◆◆◆ For lead time information see page 19.

* Directional fabrics

EMPOWER® FABRIC SCREENS — ALL PANEL MODELS

PRICE CODE B

ANALOG*	ANLG
◆ Album	ANLG06
◆ Cartridge	ANLG04
◆ Cassette	ANLG09
◆ Dial	ANLG02
◆ Media	ANLG08
◆ Reel	ANLG07
◆ Signal	ANLG03
◆ Stereo	ANLG01
◆ Track	ANLG05

COAST*

COAST*	COA
◆ Channel	COA14
◆ Dune	COA03
◆ Headlands	COA10
◆ Marsh	COA02
◆ Pebble	COA12
◆ Pier	COA13
◆ Shoal	COA01
◆ Silt	COA06
◆ Tide	COA08

DISPERSE*

DISPERSE*	DISP
◆ Autumn	DISP03
◆ Branch	DISP10
◆ Coffee Bean	DISP13
◆ Dusk	DISP09
◆ Emerald City	DISP08
◆ Gold Rush	DISP02
◆ Igloo	DISP11
◆ Ink	DISP06
◆ Mist	DISP12
◆ Oatmeal	DISP15
◆ Prince	DISP07
◆ Reservoir	DISP01
◆ Rose	DISP04
◆ Spring	DISP05
◆ Steel	DISP16
◆ Taupe	DISP14

PRICE CODE B *continued*

MICA*	MCA
◆ Anthracite	MCA11
◆ Breeze	MCA18
◆ Bronze	MCA13
◆ Buff	MCA14
◆ Cremini	MCA17
◆ Crystal	MCAWIT
◆ Dew	MCA20
◆ Dove	MCA12
◆ Fresh	MCA16
◆ Mineral	MCA15
◆ Nectar	MCA19
◆ Shale	MCA10

PRICE CODE B *continued*

SPIN*	SPIN
◆ Alabaster	SPIN02
◆ Cavern	SPIN03
◆ Cobblestone	SPIN04
◆ Ember	SPIN06
◆ Flame	SPIN07
◆ Heron	SPIN13
◆ Oat	SPIN01
◆ Ocean	SPIN12
◆ Plum	SPIN15
◆ Pool	SPIN11
◆ Raven	SPIN10
◆ Rhubarb	SPIN14
◆ Tropic	SPIN08
◆ Willow	SPIN05

PRICE CODE B *continued*

TERRAIN*	TRRN
◆ Bay	TRRN05
◆ Bayou	TRRN35
◆ Canyon	TRRN30
◆ Cliff	TRRN45
◆ Crest	TRRN25
◆ Delta	TRRN10
◆ Plateau	TRRN15
◆ Ridge	TRRN20
◆ Valley	TRRN40

NOTES: Analog, Disperse, and Exchange panel fabrics will be applied pattern cut. Disperse will not be available on 72"W panels.

◆◆◆ For lead time information see page 19.

* Directional fabrics

EMPOWER[®] FINISH OPTIONS

WORKSURFACES

L1 LAMINATES CODES

Woodgrain

- ◆ Bourbon Cherry H
- ◆ Cognac COGN
- ◆ Florence Walnut LFW1
- ◆ Harvest C
- ◆ Kingswood Walnut LK11
- ◆ Mahogany N
- ◆ Mocha MOCH
- ◆ Natural Maple D
- ◆ Pinnacle PINC
- ◆ Shaker Cherry F
- ◆ Sterling Ash LSA1

Solid

- ◆ Black P
- ◆ Charcoal S
- ◆ Designer White LDW1
- ◆ Loft LOFT

Patterned

- ◆ Canyon Zephyr K9
- ◆ Desert Zephyr K8
- ◆ Gray G2
- ◆ Grey Tigris L6
- ◆ Shadow Zephyr K1
- ◆ Sheer Mesh A5
- ◆ Silver Mesh B9
- ◆ Steel Mesh A9
- ◆ White G1
- ◆ Whitestone K4

L2 LAMINATES CODES

Woodgrain

- ◆ Lowell Ash LLA1
- ◆ Natural Recon LNR1
- ◆ Phantom Ecru LPE1
- ◆ Portico Teak LPT1
- ◆ Skyline Walnut LSW1

WORKSURFACE EDGE BAND

Woodgrain

- ◆ Bourbon Cherry H
- ◆ Cognac COGN
- ◆ Florence Walnut FW
- ◆ Harvest C
- ◆ Kingswood Walnut KI
- ◆ Lowell Ash LLA1
- ◆ Mahogany N
- ◆ Mocha MOCH
- ◆ Natural Maple D
- ◆ Natural Recon LNR1
- ◆ Phantom Ecru LPE1
- ◆ Pinnacle PINC
- ◆ Portico Teak LPT1
- ◆ Shaker Cherry F
- ◆ Skyline Walnut LSW1
- ◆ Sterling Ash SA

Solid

- ◆ Black P
- ◆ Charcoal S
- ◆ Designer White LDW1
- ◆ Greige R
- ◆ Loft LOFT
- ◆ Muslin T
- ◆ Platinum K
- ◆ Shadow * SHDW

END OF RUN SCREENS

L1 LAMINATES CODES

Woodgrain

- ◆ Bourbon Cherry H
- ◆ Cognac COGN
- ◆ Florence Walnut LFW1
- ◆ Harvest C
- ◆ Kingswood Walnut LK11
- ◆ Mahogany N
- ◆ Mocha MOCH
- ◆ Natural Maple D
- ◆ Pinnacle PINC
- ◆ Shaker Cherry F
- ◆ Sterling Ash LSA1

Solid

- ◆ Black P
- ◆ Charcoal S
- ◆ Designer White LDW1
- ◆ Loft LOFT

Patterned

- ◆ Sheer Mesh A5
- ◆ Silver Mesh B9

L2 LAMINATES CODES

Woodgrain

- ◆ Lowell Ash LLA1
- ◆ Natural Recon LNR1
- ◆ Phantom Ecru LPE1
- ◆ Portico Teak LPT1
- ◆ Skyline Walnut LSW1

STATIC LEGS AND TROUGHS

PAINTS CODES

- ◆ Black P
- ◆ Brownstone P7D
- ◆ Charcoal S
- ◆ Designer White PJW
- ◆ Fossil P28
- ◆ Greige T5
- ◆ Light Gray Q
- ◆ Loft LOFT
- ◆ Muslin T3
- ◆ Putty L
- ◆ Shadow * SHDW
- ◆ Titanium P8T

P2

- ◆ Champagne Metallic T4
- ◆ Platinum Metallic T1
- ◆ Silver PR6
- ◆ Solar Black P8X

P3

- ◆ Atom P8S
- ◆ Bullseye PJF
- ◆ Ember P8P
- ◆ Ion P8N
- ◆ Iris P8J
- ◆ Krypton P8F
- ◆ Regatta P8M

POWER POLE

PAINTS CODES

P1

- ◆ Black P
- ◆ Charcoal S
- ◆ Designer White PJW
- ◆ Greige T5
- ◆ Light Gray Q
- ◆ Loft LOFT
- ◆ Muslin T3
- ◆ Shadow * SHDW

Recommended Color to use with Duplex and Data Electric Kits

Paint	Duplex-Data Code
Black P	Black P
Brownstone P7D	Brownstone EY
Charcoal S	Charcoal S
Designer White PJW	Designer White DW
Fossil P28	Charcoal S
Greige T5	Muslin T3
Light Gray Q	Loft LOFT
Loft LOFT	Loft LOFT
Muslin T3	Muslin T3
Putty L	Black P
Shadow SHDW	Muslin T3
Silver PR6	Titanium T1
Titanium P8T	Titanium T1
Champagne Metallic T4	Muslin T3
Platinum Metallic T1	Titanium T1

PAINTED METAL SCREENS AND SCREEN BRACKETS

PAINTS CODES

P1

- ◆ Black P
- ◆ Brownstone P7D
- ◆ Charcoal S
- ◆ Designer White PJW
- ◆ Fossil P28
- ◆ Greige T5
- ◆ Light Gray Q
- ◆ Loft LOFT
- ◆ Muslin T3
- ◆ Putty L
- ◆ Shadow * SHDW
- ◆ Titanium P8T

P2

- ◆ Champagne Metallic T4
- ◆ Platinum Metallic T1
- ◆ Silver PR6
- ◆ Solar Black P8X
- ◆ White MKB

P3

- ◆ Atom P8S
- ◆ Bullseye PJF
- ◆ Ember P8P
- ◆ Ion P8N
- ◆ Iris P8J
- ◆ Krypton P8F
- ◆ Regatta P8M

WORKSURFACE LAMINATES	CODES	EDGE BAND OPTIONS						
		Matching Edge	Designer White (DW)	Loft (LOFT)	Muslin (T)	Shadow (SHDW)	Black (P)	Charcoal (S)
Black	P						•	
Bourbon Cherry	H	•	•		•			
Charcoal	S							•
Cognac	COGN	•	•		•			
Designer White	LDW1		•					
Harvest	C	•	•		•			
Loft	LOFT			•				
Lowell Ash	LLA1	•	•	•	•			
Mahogany	N	•		•		•		
Mocha	MOCH	•	•		•			
Natural Maple	D	•	•	•	•			
Natural Recon	LNR1	•	•	•	•			
Phantom Ecru	LPE1	•	•	•	•			
Pinnacle	PINC	•	•		•			
Portico Teak	LPT1	•	•	•	•			
Shaker Cherry	F	•	•	•	•	•		
Sheer Mesh	A5				•			
Silver Mesh	B9			•				
Skyline Walnut	LSW1	•	•	•	•			
Sterling Ash	LSA1	•	•	•			•	

◆◆◆ For lead time information see page 19.

* De-emphasized

EMPOWER[®] Step-by-Step Guide

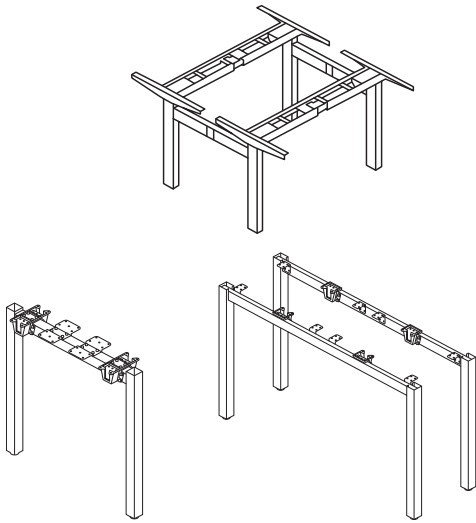

STEP 1: LEGS

All necessary brackets ship attached to the legs.

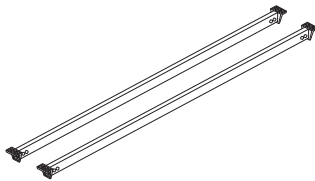

STEP 2: SUPPORT BEAMS (STATIC ONLY)

All necessary brackets ship attached to the beam. Simply fasten to the legs with the provided screws.

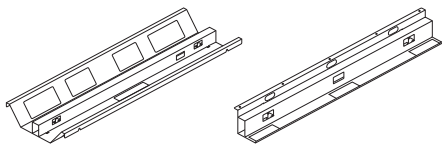

STEP 3: TROUGHS

Slide the trough over the support beams for double-sided. Screw the trough into the surface for single-sided.

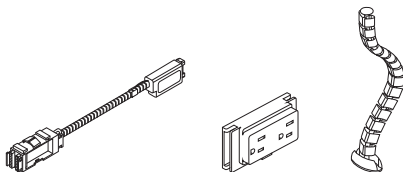

STEP 4: ELECTRICAL

Slide 8-wire harnesses/duplexes into pre-installed clips on the trough. Lay in data if necessary and cover.

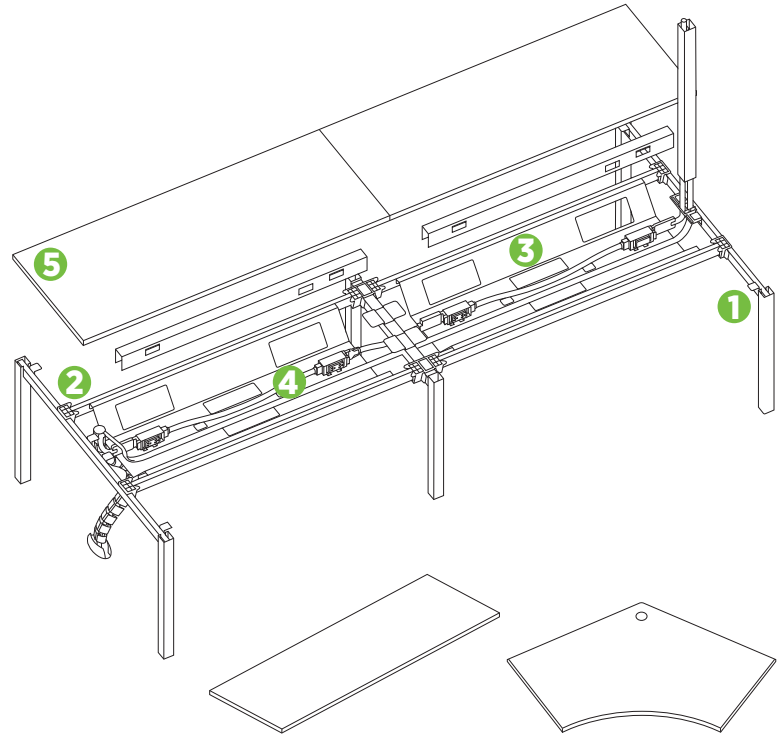

STEP 5: WORKSURFACES

All necessary brackets ship attached to the beam. Simply fasten to the legs with the provided screws.

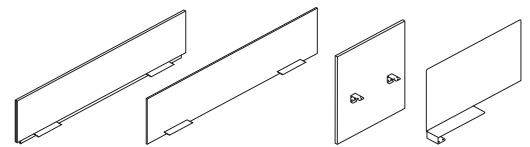

STEP 6: SCREENS

Drop shared screens into installed brackets, slide side screens into place or attach end of run screens at end of worksurfaces.

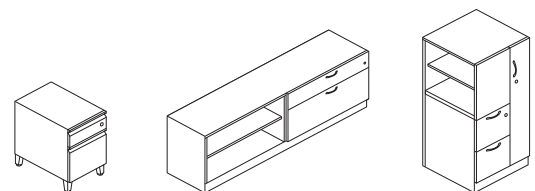

STEP 7: STORAGE

Choose your storage, from pedestals, to credenzas to towers — whatever suits your needs.

EMPOWER[®] 72"W Typicals with 24"D Worksurfaces



Icon Legend on page 19

WORKSTATIONS

QTY	DESCRIPTION	MODEL	LIST PRICE	PRICE EXTENSION
2	Worksurface, Edgeband, No Grommets 24" x 72"	HWR2472PN	\$529	\$1,058
1	Double Depth U-Leg (Box of 2)	HMPEL4828	\$1,136	\$1,136
1	Support Beams (Box of 2) 72"W	HMPUB272	\$704	\$704
1	Shared Trough 72"W	HMPROUGH72	\$479	\$479
1	End of Run Electrical Kit 72"W	HMPEEK72	\$214	\$214
1	Duplex 1	HH871501	\$43	\$43
1	Duplex 2	HH871502	\$43	\$43
1	Duplex 3	HH871503	\$43	\$43
1	Duplex 4	HH871504	\$43	\$43
TOTAL:			\$3,763	

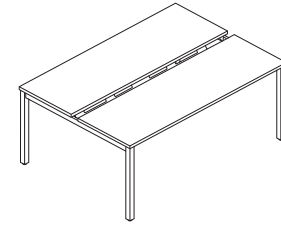

**2-PACK — 72"
72"W x 51"D**

QTY	DESCRIPTION	BUNDLE SKU	LIST PRICE
1	2-PACK BUNDLE Includes all Components Listed Above	HMP2472PK2	\$3,763

SPECIFYING EXAMPLE: Model.Laminate.Edgeband.Paint2.DuplexColor

NOTES: Typicals DO NOT include power in-feeds, screens, storage, or seating.

ADD 1 FABRIC SCREEN: \$727— SEE PAGE 495

ADD 2 MOBILE PEDESTALS: \$1,138— SEE PAGE 530

SEE PAGE 498 FOR BUNDLE SKU INFORMATION

QTY	DESCRIPTION	MODEL	LIST PRICE	PRICE EXTENSION
4	Worksurface, Edgeband, No Grommets 24" x 72"	HWR2472PN	\$529	\$2,116
1	Double Depth U-Leg (Box of 2)	HMPEL4828	\$1,136	\$1,136
1	Double Depth Shared U-Leg (Singles)	HMPSL4828	\$468	\$468
2	Support Beams (Box of 2) 72"W	HMPUB272	\$704	\$1,408
2	Shared Trough 72"W	HMPROUGH72	\$479	\$958
1	Power Harness 72"W	HH871272	\$214	\$214
1	End of Run Electrical Kit 72"W	HMPEEK72	\$214	\$214
2	Duplex 1	HH871501	\$43	\$86
2	Duplex 2	HH871502	\$43	\$86
2	Duplex 3	HH871503	\$43	\$86
2	Duplex 4	HH871504	\$43	\$86
TOTAL:			\$6,858	

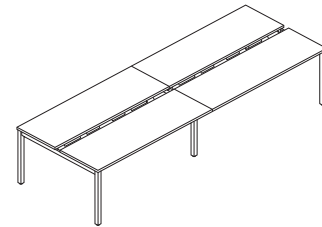

**4-PACK — 72"
144"W x 51"D**

QTY	DESCRIPTION	BUNDLE SKU	LIST PRICE
1	4-PACK BUNDLE Includes all Components Listed Above	HMP2472PK4	\$6,858

SPECIFYING EXAMPLE: Model.Laminate.Edgeband.Paint2.DuplexColor

NOTES: Typicals DO NOT include power in-feeds, screens, storage, or seating.

ADD 2 FABRIC SCREENS: \$1,454— SEE PAGE 495

ADD 4 MOBILE PEDESTALS: \$2,276— SEE PAGE 530

SEE PAGE 498 FOR BUNDLE SKU INFORMATION



Icon Legend on page 19

EMPOWER[®]

72"W Typicals with 24"D Worksurfaces

WORKSTATIONS

QTY	DESCRIPTION	MODEL	LIST PRICE	PRICE EXTENSION
6	Worksurface, Edgeband, No Grommets 24" x 72"	HWR2472PN	\$529	\$3,174
1	Double Depth U-Leg (Box of 2)	HMPEL4828	\$1,136	\$1,136
2	Double Depth Shared U-Leg (Singles)	HMPSL4828	\$468	\$936
3	Support Beams (Box of 2) 72"W	HMPUB272	\$704	\$2,112
3	Shared Trough 72"W	HMPROUGH72	\$479	\$1,437
2	Power Harness 72"W	HH871272	\$214	\$428
1	End of Run Electrical Kit 72"W	HMPEEK72	\$214	\$214
3	Duplex 1	HH871501	\$43	\$129
3	Duplex 2	HH871502	\$43	\$129
3	Duplex 3	HH871503	\$43	\$129
3	Duplex 4	HH871504	\$43	\$129
TOTAL:				\$9,953

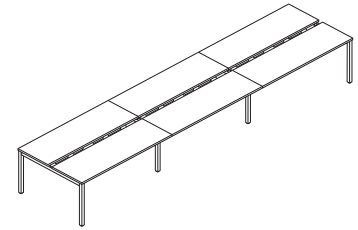

6-PACK — 72"
216"W x 51"D

QTY	DESCRIPTION	BUNDLE SKU	LIST PRICE
1	6-PACK BUNDLE Includes all Components Listed Above	HMP2472PK6	\$9,953

SPECIFYING EXAMPLE: Model.Laminate.Edgeband.Paint2.DuplexColor

NOTES: Typicals DO NOT include power in-feeds, screens, storage, or seating.

ADD 3 FABRIC SCREENS: \$2,181 — SEE PAGE 495

ADD 6 MOBILE PEDESTALS: \$3,414 — SEE PAGE 530

SEE PAGE 498 FOR BUNDLE SKU INFORMATION

QTY	DESCRIPTION	MODEL	LIST PRICE	PRICE EXTENSION
8	Worksurface, Edgeband, No Grommets 24" x 72"	HWR2472PN	\$529	\$4,232
1	Double Depth U-Leg (Box of 2)	HMPEL4828	\$1,136	\$1,136
3	Double Depth Shared U-Leg (Singles)	HMPSL4828	\$468	\$1,404
4	Support Beams (Box of 2) 72"W	HMPUB272	\$704	\$2,816
4	Shared Trough 72"W	HMPROUGH72	\$479	\$1,916
3	Power Harness 72"W	HH871272	\$214	\$642
1	End of Run Electrical Kit 72"W	HMPEEK72	\$214	\$214
4	Duplex 1	HH871501	\$43	\$172
4	Duplex 2	HH871502	\$43	\$172
4	Duplex 3	HH871503	\$43	\$172
4	Duplex 4	HH871504	\$43	\$172
TOTAL:				\$13,048

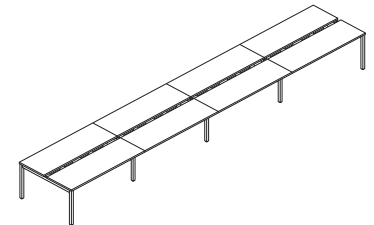

8-PACK — 72"
288"W x 51"D

QTY	DESCRIPTION	BUNDLE SKU	LIST PRICE
1	8-PACK BUNDLE Includes all Components Listed Above	HMP2472PK8	\$13,048

SPECIFYING EXAMPLE: Model.Laminate.Edgeband.Paint2.DuplexColor

NOTES: Typicals DO NOT include power in-feeds, screens, storage, or seating.

ADD 4 FABRIC SCREENS: \$2,908 — SEE PAGE 495

ADD 8 MOBILE PEDESTALS: \$4,552 — SEE PAGE 530

SEE PAGE 498 FOR BUNDLE SKU INFORMATION

EMPOWER[®] 72"W Typicals with 24"D Worksurfaces



Icon Legend on page 19

WORKSTATIONS

QTY	DESCRIPTION	MODEL	LIST PRICE	PRICE EXTENSION
2	Electrical Power Harness Panels w/Duplex Capacity	HH871272	\$214	\$428
1	End of Run Electrical Kit 72"W	HMPPEEK72	\$214	\$214
1	Duplex Receptacle Circuit 1 3-1 & 2-2 Systems	HH871501	\$43	\$43
1	Duplex Receptacle Circuit 2 3-1 & 2-2 Systems	HH871502	\$43	\$43
1	Duplex Receptacle Circuit 3 3-1 System Only	HH871503	\$43	\$43
3	Duplex Receptacle Circuit 4 3-1 & 2-2 Systems	HH871504	\$43	\$129
1	Single Depth U-Leg (Box of 2)	HMPPEL2428	\$568	\$568
1	Single Depth Return Leg — Left	HMPRLEL2428	\$345	\$345
2	Single Depth Return Leg — Right	HMPRREL2428	\$345	\$690
2	Single Depth Shared U-Leg (Singles)	HMPSL2428	\$345	\$690
3	Single-Side Trough 72"W	HMPSTROUGH72	\$508	\$1,524
2	Support Beams (Box of 1) 48"W	HMPUB148	\$286	\$572
1	Support Beams (Box of 1) 60"W	HMPUB160	\$319	\$319
3	Support Beams (Box of 1) 72"W	HMPUB172	\$353	\$1,059
2	Systems Rectangular Worksurface, Edgeband, No Grommets 24"D x 36"W	HWR2436PN	\$346	\$692
1	Systems Rectangular Worksurface, Edgeband, No Grommets 24"D x 48"W	HWR2448PN	\$404	\$404
3	Systems Rectangular Worksurface, Edgeband, No Grommets 24"D x 72"W	HWR2472PN	\$529	\$1,587
TOTAL:			\$9,350	

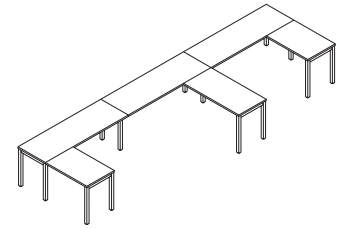

**6-PACK W/RETURNS — 72"
216"W x 72"D**

NOTES: Typicals DO NOT include power in-feeds, screens, storage, or seating.

ADD 3 FABRIC SCREENS: \$1,974 — SEE PAGE 495

ADD 3 MOBILE PEDESTALS: \$1,707 — SEE PAGE 530

SEE PAGE 498 FOR BUNDLE SKU INFORMATION

QTY	DESCRIPTION	MODEL	LIST PRICE	PRICE EXTENSION
2	Electrical Power Harness Panels w/Duplex Capacity	HH871272	\$214	\$428
1	End of Run Electrical Kit 72"W	HMPPEEK72	\$214	\$214
3	Duplex Receptacle Circuit 1 3-1 & 2-2 Systems	HH871501	\$43	\$129
3	Duplex Receptacle Circuit 2 3-1 & 2-2 Systems	HH871502	\$43	\$129
3	Duplex Receptacle Circuit 3 3-1 System Only	HH871503	\$43	\$129
3	Duplex Receptacle Circuit 4 3-1 & 2-2 Systems	HH871504	\$43	\$129
1	Double Depth U-Leg (Box of 2)	HMPPEL4828	\$1,136	\$1,136
2	Single Depth Return Leg — Left	HMPRLEL2428	\$345	\$690
2	Single Depth Return Leg — Right	HMPRREL2428	\$345	\$690
2	Double Depth Shared U-Leg (Singles)	HMPSL4828	\$468	\$936
3	Shared Trough 72"W	HMPSTROUGH72	\$479	\$1,437
3	Support Beams (Box of 1) 48"W	HMPUB148	\$286	\$858
1	Support Beams (Box of 1) 60"W	HMPUB160	\$319	\$319
3	Support Beams (Box of 2) 72"W	HMPUB272	\$704	\$2,112
3	Systems Rectangular Worksurface, Edgeband, No Grommets 24"D x 36"W	HWR2436PN	\$346	\$1,038
1	Systems Rectangular Worksurface, Edgeband, No Grommets 24"D x 48"W	HWR2448PN	\$404	\$404
6	Systems Rectangular Worksurface, Edgeband, No Grommets 24"D x 72"W	HWR2472PN	\$529	\$3,174
TOTAL:			\$13,952	

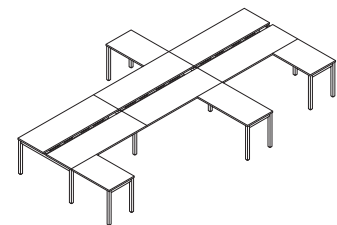

**3-PACK W/RETURNS — 72"
216"W x 132"D**

NOTES: Typicals DO NOT include power in-feeds, screens, storage, or seating.

ADD 3 FABRIC SCREENS: \$2,181 — SEE PAGE 495

ADD 6 MOBILE PEDESTALS: \$3,414 — SEE PAGE 530

SEE PAGE 498 FOR BUNDLE SKU INFORMATION



Icon Legend on page 19

EMPOWER[®]

60"W Typicals with 24"D Worksurfaces

WORKSTATIONS

QTY	DESCRIPTION	MODEL	LIST PRICE	PRICE EXTENSION
2	Worksurface, Edgeband, No Grommets 24" x 60"	HWR2460PN	\$477	\$954
1	Double Depth U-Leg (Box of 2)	HMPEL4828	\$1,136	\$1,136
1	Support Beams (Box of 2) 60"W	HMPUB260	\$635	\$635
1	Shared Trough 60"W	HMPROUGH60	\$436	\$436
1	End of Run Electrical Kit 60"W	HMPEEK60	\$214	\$214
1	Duplex 1	HH871501	\$43	\$43
1	Duplex 2	HH871502	\$43	\$43
1	Duplex 3	HH871503	\$43	\$43
1	Duplex 4	HH871504	\$43	\$43
TOTAL:			\$3,547	

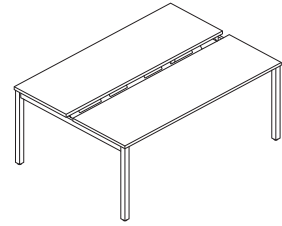

2-PACK — 60"
60"W x 51"D

QTY	DESCRIPTION	BUNDLE SKU	LIST PRICE
1	2-PACK BUNDLE Includes all Components Listed Above	HMP2460PK2	\$3,547

SPECIFYING EXAMPLE: Model.Laminate.Edgeband.Paint2.DuplexColor

NOTES: Typicals DO NOT include power in-feeds, screens, storage, or seating.

ADD 1 FABRIC SCREEN: \$656 — SEE PAGE 495

ADD 2 MOBILE PEDESTALS: \$1,138 — SEE PAGE 530

SEE PAGE 498 FOR BUNDLE SKU INFORMATION

QTY	DESCRIPTION	MODEL	LIST PRICE	PRICE EXTENSION
4	Worksurface, Edgeband, No Grommets 24" x 60"	HWR2460PN	\$477	\$1,908
1	Double Depth U-Leg (Box of 2)	HMPEL4828	\$1,136	\$1,136
1	Double Depth Shared U-Leg (Singles)	HMPSL4828	\$468	\$468
2	Support Beams (Box of 2) 60"W	HMPUB260	\$635	\$1,270
2	Shared Trough 60"W	HMPROUGH60	\$436	\$872
1	Power Harness 60"W	HH871260	\$214	\$214
1	End of Run Electrical Kit 60"W	HMPEEK60	\$214	\$214
2	Duplex 1	HH871501	\$43	\$86
2	Duplex 2	HH871502	\$43	\$86
2	Duplex 3	HH871503	\$43	\$86
2	Duplex 4	HH871504	\$43	\$86
TOTAL:			\$6,426	

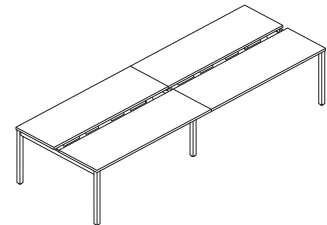

4-PACK — 60"
144"W x 51"D

QTY	DESCRIPTION	BUNDLE SKU	LIST PRICE
1	4-PACK BUNDLE Includes all Components Listed Above	HMP2460PK4	\$6,426

SPECIFYING EXAMPLE: Model.Laminate.Edgeband.Paint2.DuplexColor

NOTES: Typicals DO NOT include power in-feeds, screens, storage, or seating.

ADD 2 FABRIC SCREENS: \$1,312 — SEE PAGE 495

ADD 4 MOBILE PEDESTALS: \$2,276 — SEE PAGE 530

SEE PAGE 498 FOR BUNDLE SKU INFORMATION

EMPOWER®

60"W Typicals with 24"D Worksurfaces



Icon Legend on page 19

WORKSTATIONS

QTY	DESCRIPTION	MODEL	LIST PRICE	PRICE EXTENSION
6	Worksurface, Edgeband, No Grommets 24" x 60"	HWR2460PN	\$477	\$2,862
1	Double Depth U-Leg (Box of 2)	HMPEL4828	\$1,136	\$1,136
2	Double Depth Shared U-Leg (Singles)	HMPSL4828	\$468	\$936
3	Support Beams (Box of 2) 60"W	HMPUB260	\$635	\$1,905
3	Shared Trough 60"W	HMPTROUGH60	\$436	\$1,308
2	Power Harness 60"W	HH871260	\$214	\$428
1	End of Run Electrical Kit 60"W	HMPEEK60	\$214	\$214
3	Duplex 1	HH871501	\$43	\$129
3	Duplex 2	HH871502	\$43	\$129
3	Duplex 3	HH871503	\$43	\$129
3	Duplex 4	HH871504	\$43	\$129
TOTAL:				\$9,305

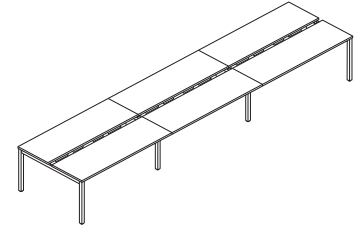

**6-PACK — 60"
180"W x 51"D**

QTY	DESCRIPTION	BUNDLE SKU	LIST PRICE
1	6-PACK BUNDLE Includes all Components Listed Above	HMP2460PK6	\$9,305

SPECIFYING EXAMPLE: Model.Laminate.Edgeband.Paint2.DuplexColor

NOTES: Typicals DO NOT include power in-feeds, screens, storage, or seating.

ADD 3 FABRIC SCREENS: \$1,968 — SEE PAGE 495

ADD 6 MOBILE PEDESTALS: \$3,414 — SEE PAGE 530

SEE PAGE 498 FOR BUNDLE SKU INFORMATION

QTY	DESCRIPTION	MODEL	LIST PRICE	PRICE EXTENSION
8	Worksurface, Edgeband, No Grommets 24" x 60"	HWR2460PN	\$477	\$3,816
1	Double Depth U-Leg (Box of 2)	HMPEL4828	\$1,136	\$1,136
3	Double Depth Shared U-Leg (Singles)	HMPSL4828	\$468	\$1,404
4	Support Beams (Box of 2) 60"W	HMPUB260	\$635	\$2,540
4	Shared Trough 60"W	HMPTROUGH60	\$436	\$1,744
3	Power Harness 60"W	HH871260	\$214	\$642
1	End of Run Electrical Kit 60"W	HMPEEK60	\$214	\$214
4	Duplex 1	HH871501	\$43	\$172
4	Duplex 2	HH871502	\$43	\$172
4	Duplex 3	HH871503	\$43	\$172
4	Duplex 4	HH871504	\$43	\$172
TOTAL:				\$12,184

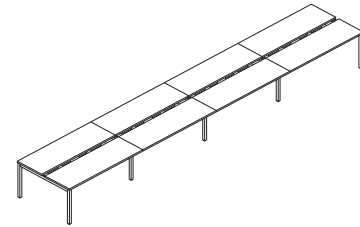

**8-PACK — 60"
240"W x 51"D**

QTY	DESCRIPTION	BUNDLE SKU	LIST PRICE
1	8-PACK BUNDLE Includes all Components Listed Above	HMP2460PK8	\$12,184

SPECIFYING EXAMPLE: Model.Laminate.Edgeband.Paint2.DuplexColor

NOTES: Typicals DO NOT include power in-feeds, screens, storage, or seating.

ADD 4 FABRIC SCREENS: \$2,624 — SEE PAGE 495

ADD 8 MOBILE PEDESTALS: \$4,552 — SEE PAGE 530

SEE PAGE 498 FOR BUNDLE SKU INFORMATION



Icon Legend on page 19

EMPOWER[®]

72"W Typical with 30"D Worksurfaces

WORKSTATIONS

QTY	DESCRIPTION	MODEL	LIST PRICE	PRICE EXTENSION
2	Worksurface, Edgeband, No Grommets 30" x 72"	HWR3072PN	\$593	\$1,186
1	Double Depth U-Leg (Box of 2)	HMPEL6028	\$1,249	\$1,249
1	Support Beams (Box of 2) 72"W	HMPUB272	\$704	\$704
1	Shared Trough 72"W	HMPROUGH72	\$479	\$479
1	End of Run Electrical Kit 72"W	HMPEEK72	\$214	\$214
1	Duplex 1	HH871501	\$43	\$43
1	Duplex 2	HH871502	\$43	\$43
1	Duplex 3	HH871503	\$43	\$43
1	Duplex 4	HH871504	\$43	\$43
TOTAL:			\$4,004	

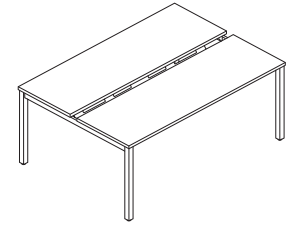

2-PACK — 72"
72"W x 63"D

QTY	DESCRIPTION	BUNDLE SKU	LIST PRICE
1	2-PACK BUNDLE Includes all Components Listed Above	HMP3072PK2	\$4,004

SPECIFYING EXAMPLE: Model.Laminate.Edgeband.Paint2.DuplexColor

NOTES: Typicals DO NOT include power in-feeds, screens, storage, or seating.

ADD 1 FABRIC SCREEN: \$727 — SEE PAGE 495

ADD 2 MOBILE PEDESTALS: \$1,138 — SEE PAGE 530

SEE PAGE 498 FOR BUNDLE SKU INFORMATION

QTY	DESCRIPTION	MODEL	LIST PRICE	PRICE EXTENSION
4	Worksurface, Edgeband, No Grommets 30" x 72"	HWR3072PN	\$593	\$2,372
1	Double Depth U-Leg (Box of 2)	HMPEL6028	\$1,249	\$1,249
1	Double Depth Shared U-Leg (Singles)	HMPSL6028	\$514	\$514
2	Support Beams (Box of 2) 72"W	HMPUB272	\$704	\$1,408
2	Shared Trough 72"W	HMPROUGH72	\$479	\$958
1	Power Harness 72"W	HH871272	\$214	\$214
1	End of Run Electrical Kit 72"W	HMPEEK72	\$214	\$214
2	Duplex 1	HH871501	\$43	\$86
2	Duplex 2	HH871502	\$43	\$86
2	Duplex 3	HH871503	\$43	\$86
2	Duplex 4	HH871504	\$43	\$86
TOTAL:			\$7,273	

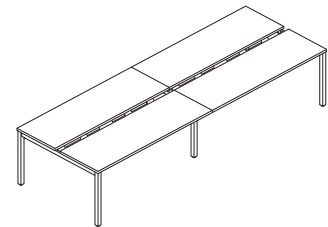

4-PACK — 72"
144"W x 63"D

QTY	DESCRIPTION	BUNDLE SKU	LIST PRICE
1	4-PACK BUNDLE Includes all Components Listed Above	HMP3072PK4	\$7,273

SPECIFYING EXAMPLE: Model.Laminate.Edgeband.Paint2.DuplexColor

NOTES: Typicals DO NOT include power in-feeds, screens, storage, or seating.

ADD 2 FABRIC SCREENS: \$1,454 — SEE PAGE 495

ADD 4 MOBILE PEDESTALS: \$2,276 — SEE PAGE 530

SEE PAGE 498 FOR BUNDLE SKU INFORMATION

EMPOWER® 72"W Typicals with 30"D Worksurfaces



Icon Legend on page 19

WORKSTATIONS

QTY	DESCRIPTION	MODEL	LIST PRICE	PRICE EXTENSION
6	Worksurface, Edgeband, No Grommets 30" x 72"	HWR3072PN	\$593	\$3,558
1	Double Depth U-Leg (Box of 2)	HMPEL6028	\$1,249	\$1,249
2	Double Depth Shared U-Leg (Singles)	HMPSL6028	\$514	\$1,028
3	Support Beams (Box of 2) 72"W	HMPUB272	\$704	\$2,112
3	Shared Trough 72"W	HMPTROUGH72	\$479	\$1,437
2	Power Harness 72"W	HH871272	\$214	\$428
1	End of Run Electrical Kit 72"W	HMPEEK72	\$214	\$214
3	Duplex 1	HH871501	\$43	\$129
3	Duplex 2	HH871502	\$43	\$129
3	Duplex 3	HH871503	\$43	\$129
3	Duplex 4	HH871504	\$43	\$129
TOTAL:				\$10,542

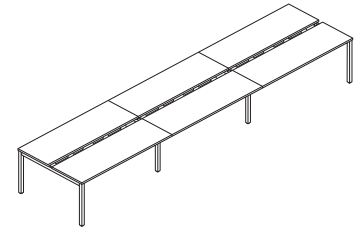

**6-PACK — 72"
216"W x 63"D**

QTY	DESCRIPTION	BUNDLE SKU	LIST PRICE
1	6-PACK BUNDLE Includes all Components Listed Above	HMP3072PK6	\$10,542

SPECIFYING EXAMPLE: Model.Laminate.Edgeband.Paint2.DuplexColor

NOTES: Typicals DO NOT include power in-feeds, screens, storage, or seating.

ADD 3 FABRIC SCREENS: \$2,181 — SEE PAGE 495

ADD 6 MOBILE PEDESTALS: \$3,414 — SEE PAGE 530

SEE PAGE 498 FOR BUNDLE SKU INFORMATION

QTY	DESCRIPTION	MODEL	LIST PRICE	PRICE EXTENSION
8	Worksurface, Edgeband, No Grommets 30" x 72"	HWR3072PN	\$593	\$4,744
1	Double Depth U-Leg (Box of 2)	HMPEL6028	\$1,249	\$1,249
3	Double Depth Shared U-Leg (Singles)	HMPSL6028	\$514	\$1,542
4	Support Beams (Box of 2) 72"W	HMPUB272	\$704	\$2,816
4	Shared Trough 72"W	HMPTROUGH72	\$479	\$1,916
3	Power Harness 72"W	HH871272	\$214	\$642
1	End of Run Electrical Kit 72"W	HMPEEK72	\$214	\$214
4	Duplex 1	HH871501	\$43	\$172
4	Duplex 2	HH871502	\$43	\$172
4	Duplex 3	HH871503	\$43	\$172
4	Duplex 4	HH871504	\$43	\$172
TOTAL:				\$13,811

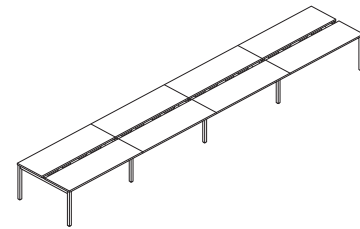

**8-PACK — 72"
288"W x 63"D**

QTY	DESCRIPTION	BUNDLE SKU	LIST PRICE
1	8-PACK BUNDLE Includes all Components Listed Above	HMP3072PK8	\$13,811

SPECIFYING EXAMPLE: Model.Laminate.Edgeband.Paint2.DuplexColor

NOTES: Typicals DO NOT include power in-feeds, screens, storage, or seating.

ADD 4 FABRIC SCREENS: \$2,908 — SEE PAGE 495

ADD 8 MOBILE PEDESTALS: \$4,552 — SEE PAGE 530

SEE PAGE 498 FOR BUNDLE SKU INFORMATION



Icon Legend on page 19

EMPOWER[®]

60"W Typical with 30"D Worksurfaces

WORKSTATIONS

QTY	DESCRIPTION	MODEL	LIST PRICE	PRICE EXTENSION
2	Worksurface, Edgeband, No Grommets 30" x 60"	HWR3060PN	\$520	\$1,040
1	Double Depth U-Leg (Box of 2)	HMPEL6028	\$1,249	\$1,249
1	Support Beams (Box of 2) 60"W	HMPUB260	\$635	\$635
1	Shared Trough 60"W	HMPROUGH60	\$436	\$436
1	End of Run Electrical Kit 60"W	HMPEEK60	\$214	\$214
1	Duplex 1	HH871501	\$43	\$43
1	Duplex 2	HH871502	\$43	\$43
1	Duplex 3	HH871503	\$43	\$43
1	Duplex 4	HH871504	\$43	\$43
TOTAL:			\$3,746	

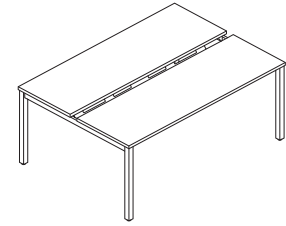

2-PACK — 60"
60"W x 63"D

QTY	DESCRIPTION	BUNDLE SKU	LIST PRICE
1	2-PACK BUNDLE Includes all Components Listed Above	HMP3060PK2	\$3,746

SPECIFYING EXAMPLE: Model.Laminate.Edgeband.Paint2.DuplexColor

NOTES: Typicals DO NOT include power in-feeds, screens, storage, or seating.

ADD 1 FABRIC SCREEN: \$656 — SEE PAGE 495

ADD 2 MOBILE PEDESTALS: \$1,138 — SEE PAGE 530

SEE PAGE 498 FOR BUNDLE SKU INFORMATION

QTY	DESCRIPTION	MODEL	LIST PRICE	PRICE EXTENSION
4	Worksurface, Edgeband, No Grommets 30" x 60"	HWR3060PN	\$520	\$2,080
1	Double Depth U-Leg (Box of 2)	HMPEL6028	\$1,249	\$1,249
1	Double Depth Shared U-Leg (Singles)	HMPSL6028	\$514	\$514
2	Support Beams (Box of 2) 60"W	HMPUB260	\$635	\$1,270
2	Shared Trough 60"W	HMPROUGH60	\$436	\$872
1	Power Harness 60"W	HH871260	\$214	\$214
1	End of Run Electrical Kit 60"W	HMPEEK60	\$214	\$214
2	Duplex 1	HH871501	\$43	\$86
2	Duplex 2	HH871502	\$43	\$86
2	Duplex 3	HH871503	\$43	\$86
2	Duplex 4	HH871504	\$43	\$86
TOTAL:			\$6,757	

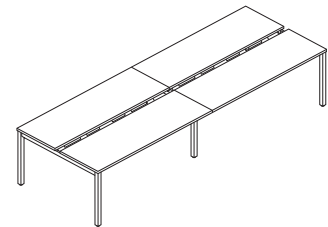

4-PACK — 60"
144"W x 63"D

QTY	DESCRIPTION	BUNDLE SKU	LIST PRICE
1	4-PACK BUNDLE Includes all Components Listed Above	HMP3060PK4	\$6,757

SPECIFYING EXAMPLE: Model.Laminate.Edgeband.Paint2.DuplexColor

NOTES: Typicals DO NOT include power in-feeds, screens, storage, or seating.

ADD 2 FABRIC SCREENS: \$1,312 — SEE PAGE 495

ADD 4 MOBILE PEDESTALS: \$2,276 — SEE PAGE 530

SEE PAGE 498 FOR BUNDLE SKU INFORMATION

EMPOWER[®]

60"W Typicals with 30"D Worksurfaces



Icon Legend on page 19

QTY	DESCRIPTION	MODEL	LIST PRICE	PRICE EXTENSION
6	Worksurface, Edgeband, No Grommets 30" x 60"	HWR3060PN	\$520	\$3,120
1	Double Depth U-Leg (Box of 2)	HMPEL6028	\$1,249	\$1,249
2	Double Depth Shared U-Leg (Singles)	HMPSL6028	\$514	\$1,028
3	Support Beams (Box of 2) 60"W	HMPUB260	\$635	\$1,905
3	Shared Trough 60"W	HMPTROUGH60	\$436	\$1,308
2	Power Harness 60"W	HH871260	\$214	\$428
1	End of Run Electrical Kit 60"W	HMPEEK60	\$214	\$214
3	Duplex 1	HH871501	\$43	\$129
3	Duplex 2	HH871502	\$43	\$129
3	Duplex 3	HH871503	\$43	\$129
3	Duplex 4	HH871504	\$43	\$129
TOTAL:				\$9,768

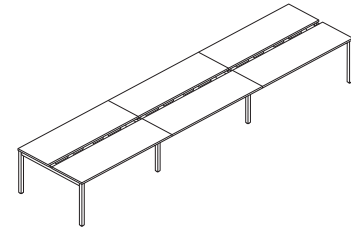

**6-PACK — 60"
180"W x 63"D**

QTY	DESCRIPTION	BUNDLE SKU	LIST PRICE
1	6-PACK BUNDLE Includes all Components Listed Above	HMP3060PK6	\$9,768

SPECIFYING EXAMPLE: Model.Laminate.Edgeband.Paint2.DuplexColor

NOTES: Typicals DO NOT include power in-feeds, screens, storage, or seating.

ADD 3 FABRIC SCREENS: \$1,968 — SEE PAGE 495

ADD 6 MOBILE PEDESTALS: \$3,414 — SEE PAGE 530

SEE PAGE 498 FOR BUNDLE SKU INFORMATION

QTY	DESCRIPTION	MODEL	LIST PRICE	PRICE EXTENSION
8	Worksurface, Edgeband, No Grommets 30" x 60"	HWR3060PN	\$520	\$4,160
1	Double Depth U-Leg (Box of 2)	HMPEL6028	\$1,249	\$1,249
3	Double Depth Shared U-Leg (Singles)	HMPSL6028	\$514	\$1,542
4	Support Beams (Box of 2) 60"W	HMPUB260	\$635	\$2,540
4	Shared Trough 60"W	HMPTROUGH60	\$436	\$1,744
3	Power Harness 60"W	HH871260	\$214	\$642
1	End of Run Electrical Kit 60"W	HMPEEK60	\$214	\$214
4	Duplex 1	HH871501	\$43	\$172
4	Duplex 2	HH871502	\$43	\$172
4	Duplex 3	HH871503	\$43	\$172
4	Duplex 4	HH871504	\$43	\$172
TOTAL:				\$12,779

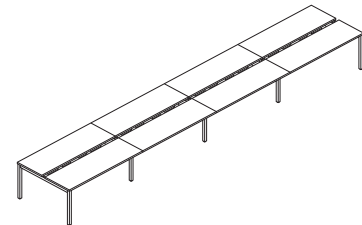

**8-PACK — 60"
240"W x 63"D**

QTY	DESCRIPTION	BUNDLE SKU	LIST PRICE
1	8-PACK BUNDLE Includes all Components Listed Above	HMP3060PK8	\$12,779

SPECIFYING EXAMPLE: Model.Laminate.Edgeband.Paint2.DuplexColor

NOTES: Typicals DO NOT include power in-feeds, screens, storage, or seating.

ADD 4 FABRIC SCREENS: \$2,624 — SEE PAGE 495

ADD 8 MOBILE PEDESTALS: \$4,552 — SEE PAGE 530

SEE PAGE 498 FOR BUNDLE SKU INFORMATION



Icon Legend on page 19

EMPOWER® 120° Workstation Typicals

QTY	DESCRIPTION	MODEL	LIST PRICE	PRICE EXTENSION
3	120 Degree Corner Worksurfaces with Curved User Edge, No Grommets 48"W x 30"D	HBWCT4830PN	\$1,164	\$3,492
3	Double Depth U-Leg (Single Leg)	HMP120EL4828	\$569	\$1,707
3	Single Post Leg 28½"H	HMP120POST	\$297	\$891
3	Support Beams (Box of 2) 48"W	HMP120UB248	\$571	\$1,713
3	Double-Sided Trough 48"W	HMP120TROUGH48	\$396	\$1,188
TOTAL:				\$8,991

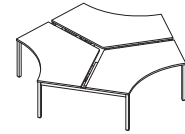

3-PACK – 120°

NOTES: Typicals DO NOT include power in-feeds, screens, storage, or seating.

ADD 3 FABRIC SCREENS: \$1,662 — SEE PAGE 495

ADD 3 MOBILE PEDESTALS: \$1,707 — SEE PAGE 530

QTY	DESCRIPTION	MODEL	LIST PRICE	PRICE EXTENSION
6	120 Degree Corner Worksurfaces with Curved User Edge, No Grommets 48"W x 30"D	HBWCT4830PN	\$1,164	\$6,984
4	Double Depth U-Leg (Single Leg)	HMP120EL4828	\$569	\$2,276
6	Single Post Leg 28½"H	HMP120POST	\$297	\$1,782
6	Support Beams (Box of 2) 48"W	HMP120UB248	\$571	\$3,426
6	Double-Sided Trough 48"W	HMP120TROUGH48	\$396	\$2,376
2	Double Depth Shared U-Leg (Singles)	HMP120SL4828	\$468	\$936
2	Worksurface with Edgeband 48"W x 30"D	HWR3048PN	\$436	\$872
1	Support Beams (Box of 2) 48"W	HMPUB248	\$571	\$571
1	Double-Sided Trough 48"W	HMP120TROUGH48	\$396	\$396
TOTAL:				\$19,619

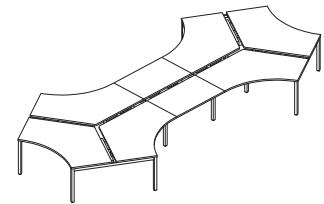

DOG BONE – 120°

NOTES: Typicals DO NOT include power in-feeds, screens, storage, or seating.

ADD 7 FABRIC SCREENS: \$3,878 — SEE PAGE 495

ADD 6 MOBILE PEDESTALS: \$3,414 — SEE PAGE 530

EMPOWER® 120° Workstation Typical



Icon Legend on page 19

WORKSTATIONS

QTY	DESCRIPTION	MODEL	LIST PRICE	PRICE EXTENSION
9	120 Degree Corner Worksurfaces with Curved User Edge, No Grommets 48"W x 30"D	HBWCT4830PN	\$1,164	\$10,476
5	Double Depth U-Leg (Single Leg)	HMP120EL4828	\$569	\$2,845
9	Single Post Leg 28½"H	HMP120POST	\$297	\$2,673
9	Support Beams (Box of 2) 48"W	HMP120UB248	\$571	\$5,139
9	Double-Sided Trough 48"W	HMP120TROUGH48	\$396	\$3,564
2	Double Depth Shared U-Leg (Singles)	HMPSL4828	\$468	\$936
TOTAL:				\$25,633

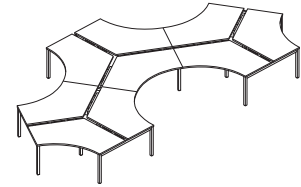

MULTIPLE PODS — 120°

NOTES: Typical DO NOT include power in-feeds, screens, storage, or seating.

ADD 9 FABRIC SCREENS: \$4,986 — SEE PAGE 495

ADD 9 MOBILE PEDESTALS: \$5,121 — SEE PAGE 530



Icon Legend on page 19

72"W Height Adjustable Typicals with 24"D Worksurfaces

QTY	DESCRIPTION	MODEL	LIST PRICE	PRICE EXTENSION
2	Worksurface, Edgeband, No Grommets 24" x 72"	HHAW2472PN	\$552	\$1,104
1	Height Adjustable Base	HMPHA2S4C	\$2,286	\$2,286
1	Height Adjustable Shared Trough 72"W	HMPHATROUGH72	\$479	\$479
2	Single-Sided Trough Lid	HMPHASLID72	\$138	\$276
1	End of Run Electrical Kit 72"W	HMPEEK72	\$214	\$214
1	Duplex 1	HH871501	\$43	\$43
1	Duplex 2	HH871502	\$43	\$43
1	Duplex 3	HH871503	\$43	\$43
1	Duplex 4	HH871504	\$43	\$43
TOTAL:				\$4,531

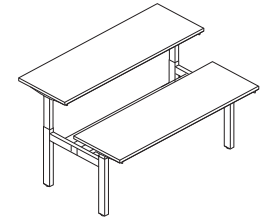
**2-PACK — 72"**
72"W x 51"D

QTY	DESCRIPTION	BUNDLE SKU	LIST PRICE
1	2-PACK BUNDLE Includes all Components Listed Above	HMPHA2472PK2	\$4,531

SPECIFYING EXAMPLE: Model.Laminate.Edgeband.BasePaint.TroughPaint.DuplexColor

NOTES: Typicals DO NOT include power in-feeds, screens, storage, or seating.

ADD 2 FABRIC SCREENS: \$1,454— SEE PAGE 495

ADD 2 MOBILE PEDESTALS: \$1,138— SEE PAGE 530

SEE PAGE 499 FOR BUNDLE SKU INFORMATION

QTY	DESCRIPTION	MODEL	LIST PRICE	PRICE EXTENSION
4	Worksurface, Edgeband, No Grommets 24" x 72"	HHAW2472PN	\$552	\$2,208
2	Height Adjustable Base	HMPHA2S4C	\$2,286	\$4,572
2	Height Adjustable Shared Trough 72"W	HMPHATROUGH72	\$479	\$958
4	Single-Sided Trough Lid	HMPHASLID72	\$138	\$552
1	Power Harness 72"W	HH871272	\$214	\$214
1	End of Run Electrical Kit 72"W	HMPEEK72	\$214	\$214
2	Duplex 1	HH871501	\$43	\$86
2	Duplex 2	HH871502	\$43	\$86
2	Duplex 3	HH871503	\$43	\$86
2	Duplex 4	HH871504	\$43	\$86
TOTAL:				\$9,062

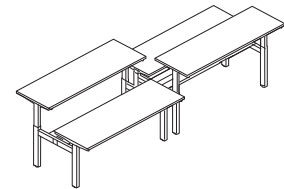
**4-PACK — 72"**
144"W x 51"D

QTY	DESCRIPTION	BUNDLE SKU	LIST PRICE
1	4-PACK BUNDLE Includes all Components Listed Above	HMPHA2472PK4	\$9,062

SPECIFYING EXAMPLE: Model.Laminate.Edgeband.BasePaint.TroughPaint.DuplexColor

NOTES: Typicals DO NOT include power in-feeds, screens, storage, or seating.

ADD 4 FABRIC SCREENS: \$2,908— SEE PAGE 495

ADD 4 MOBILE PEDESTALS: \$2,276— SEE PAGE 530

SEE PAGE 499 FOR BUNDLE SKU INFORMATION



QTY	DESCRIPTION	MODEL	LIST PRICE	PRICE EXTENSION
6	Worksurface, Edgeband, No Grommets 24" x 72"	HHAW2472PN	\$552	\$3,312
3	Height Adjustable Base	HMPHA2S4C	\$2,286	\$6,858
3	Height Adjustable Shared Trough 72"W	HMPHATROUGH72	\$479	\$1,437
6	Single-Sided Trough Lid	HMPHASLID72	\$138	\$828
2	Power Harness 72"W	HH871272	\$214	\$428
1	End of Run Electrical Kit 72"W	HMPEEK72	\$214	\$214
3	Duplex 1	HH871501	\$43	\$129
3	Duplex 2	HH871502	\$43	\$129
3	Duplex 3	HH871503	\$43	\$129
3	Duplex 4	HH871504	\$43	\$129
TOTAL:				\$13,593

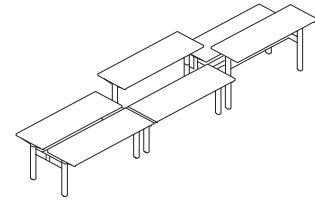

6-PACK — 72"
216"W x 51"D

QTY	DESCRIPTION	BUNDLE SKU	LIST PRICE
1	6-PACK BUNDLE Includes all Components Listed Above	HMPHA2472PK6	\$13,593

SPECIFYING EXAMPLE: Model.Laminate.Edgeband.BasePaint.TroughPaint.DuplexColor

NOTES: Typicals DO NOT include power in-feeds, screens, storage, or seating.

ADD 6 FABRIC SCREENS: \$4,362 — SEE PAGE 495

ADD 6 MOBILE PEDESTALS: \$3,414 — SEE PAGE 530

SEE PAGE 499 FOR BUNDLE SKU INFORMATION

QTY	DESCRIPTION	MODEL	LIST PRICE	PRICE EXTENSION
8	Worksurface, Edgeband, No Grommets 24" x 72"	HHAW2472PN	\$552	\$4,416
4	Height Adjustable Base	HMPHA2S4C	\$2,286	\$9,144
4	Height Adjustable Shared Trough 72"W	HMPHATROUGH72	\$479	\$1,916
8	Single-Sided Trough Lid	HMPHASLID72	\$138	\$1,104
3	Power Harness 72"W	HH871272	\$214	\$642
1	End of Run Electrical Kit 72"W	HMPEEK72	\$214	\$214
4	Duplex 1	HH871501	\$43	\$172
4	Duplex 2	HH871502	\$43	\$172
4	Duplex 3	HH871503	\$43	\$172
4	Duplex 4	HH871504	\$43	\$172
TOTAL:				\$18,124

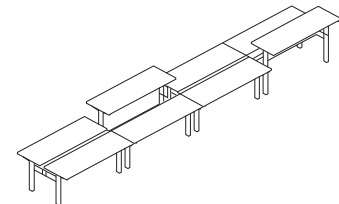

8-PACK — 72"
288"W x 51"D

QTY	DESCRIPTION	BUNDLE SKU	LIST PRICE
1	8-PACK BUNDLE Includes all Components Listed Above	HMPHA2472PK8	\$18,124

SPECIFYING EXAMPLE: Model.Laminate.Edgeband.BasePaint.TroughPaint.DuplexColor

NOTES: Typicals DO NOT include power in-feeds, screens, storage, or seating.

ADD 8 FABRIC SCREENS: \$5,816 — SEE PAGE 495

ADD 8 MOBILE PEDESTALS: \$4,552 — SEE PAGE 530

SEE PAGE 499 FOR BUNDLE SKU INFORMATION



Icon Legend on page 19

QTY	DESCRIPTION	MODEL	LIST PRICE	PRICE EXTENSION
2	Worksurface, Edgeband, No Grommets 24" x 60"	HHAW2460PN	\$499	\$998
1	Height Adjustable Base	HMPHA2S4C	\$2,286	\$2,286
1	Height Adjustable Shared Trough 60"W	HMPHATROUGH60	\$436	\$436
2	Single-Sided Trough Lid	HMPHASLID60	\$126	\$252
1	End of Run Electrical Kit 60"W	HMPEEK60	\$214	\$214
1	Duplex 1	HH871501	\$43	\$43
1	Duplex 2	HH871502	\$43	\$43
1	Duplex 3	HH871503	\$43	\$43
1	Duplex 4	HH871504	\$43	\$43
TOTAL:				\$4,358

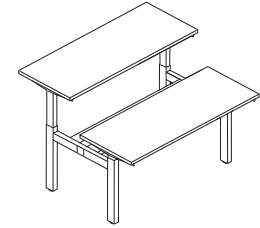
**2-PACK — 60"
60"W x 51"D**

QTY	DESCRIPTION	BUNDLE SKU	LIST PRICE
1	2-PACK BUNDLE Includes all Components Listed Above	HMPHA2460PK2	\$4,358

SPECIFYING EXAMPLE: Model.Laminate.Edgeband.BasePaint.TroughPaint.DuplexColor

NOTES: Typicals DO NOT include power in-feeds, screens, storage, or seating.

ADD 2 FABRIC SCREENS: \$1,312 — SEE PAGE 495**ADD 2 MOBILE PEDESTALS: \$1,138 — SEE PAGE 530****SEE PAGE 499 FOR BUNDLE SKU INFORMATION**

QTY	DESCRIPTION	MODEL	LIST PRICE	PRICE EXTENSION
4	Worksurface, Edgeband, No Grommets 24" x 60"	HHAW2460PN	\$499	\$1,996
2	Height Adjustable Base	HMPHA2S4C	\$2,286	\$4,572
2	Height Adjustable Shared Trough 60"W	HMPHATROUGH60	\$436	\$872
4	Single-Sided Trough Lid	HMPHASLID60	\$126	\$504
1	Power Harness 60"W	HH871260	\$214	\$214
1	End of Run Electrical Kit 60"W	HMPEEK60	\$214	\$214
2	Duplex 1	HH871501	\$43	\$86
2	Duplex 2	HH871502	\$43	\$86
2	Duplex 3	HH871503	\$43	\$86
2	Duplex 4	HH871504	\$43	\$86
TOTAL:				\$8,716

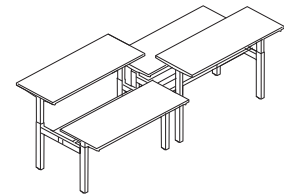
**4-PACK — 60"
120"W x 51"D**

QTY	DESCRIPTION	BUNDLE SKU	LIST PRICE
1	4-PACK BUNDLE Includes all Components Listed Above	HMPHA2460PK4	\$8,716

SPECIFYING EXAMPLE: Model.Laminate.Edgeband.BasePaint.TroughPaint.DuplexColor

NOTES: Typicals DO NOT include power in-feeds, screens, storage, or seating.

ADD 4 FABRIC SCREENS: \$2,624 — SEE PAGE 495**ADD 4 MOBILE PEDESTALS: \$2,276 — SEE PAGE 530****SEE PAGE 499 FOR BUNDLE SKU INFORMATION**



QTY	DESCRIPTION	MODEL	LIST PRICE	PRICE EXTENSION
6	Worksurface, Edgeband, No Grommets 24" x 60"	HHAW2460PN	\$499	\$2,994
3	Height Adjustable Base	HMPHA2S4C	\$2,286	\$6,858
3	Height Adjustable Shared Trough 60"W	HMPHATROUGH60	\$436	\$1,308
6	Single-Sided Trough Lid	HMPHASLID60	\$126	\$756
2	Power Harness 60"W	HH871260	\$214	\$428
1	End of Run Electrical Kit 60"W	HMPEEK60	\$214	\$214
3	Duplex 1	HH871501	\$43	\$129
3	Duplex 2	HH871502	\$43	\$129
3	Duplex 3	HH871503	\$43	\$129
3	Duplex 4	HH871504	\$43	\$129
TOTAL:				\$13,074

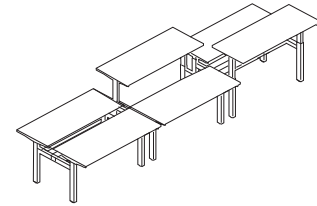

6-PACK — 60"
180"W x 51"D

QTY	DESCRIPTION	BUNDLE SKU	LIST PRICE
1	6-PACK BUNDLE Includes all Components Listed Above	HMPHA2460PK6	\$13,074

SPECIFYING EXAMPLE: Model.Laminate.Edgeband.BasePaint.TroughPaint.DuplexColor

NOTES: Typicals DO NOT include power in-feeds, screens, storage, or seating.

ADD 6 FABRIC SCREENS: \$3,936 — SEE PAGE 495

ADD 6 MOBILE PEDESTALS: \$3,414 — SEE PAGE 530

SEE PAGE 499 FOR BUNDLE SKU INFORMATION

QTY	DESCRIPTION	MODEL	LIST PRICE	PRICE EXTENSION
8	Worksurface, Edgeband, No Grommets 24" x 60"	HHAW2460PN	\$499	\$3,992
4	Height Adjustable Base	HMPHA2S4C	\$2,286	\$9,144
4	Height Adjustable Shared Trough 60"W	HMPHATROUGH60	\$436	\$1,744
8	Single-Sided Trough Lid	HMPHASLID60	\$126	\$1,008
3	Power Harness 60"W	HH871260	\$214	\$642
1	End of Run Electrical Kit 60"W	HMPEEK60	\$214	\$214
4	Duplex 1	HH871501	\$43	\$172
4	Duplex 2	HH871502	\$43	\$172
4	Duplex 3	HH871503	\$43	\$172
4	Duplex 4	HH871504	\$43	\$172
TOTAL:				\$17,432

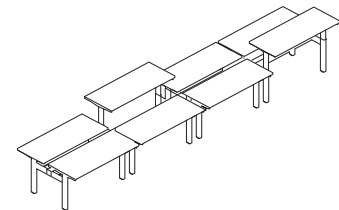

8-PACK — 60"
240"W x 51"D

QTY	DESCRIPTION	BUNDLE SKU	LIST PRICE
1	8-PACK BUNDLE Includes all Components Listed Above	HMPHA2460PK8	\$17,432

SPECIFYING EXAMPLE: Model.Laminate.Edgeband.BasePaint.TroughPaint.DuplexColor

NOTES: Typicals DO NOT include power in-feeds, screens, storage, or seating.

ADD 8 FABRIC SCREENS: \$5,248 — SEE PAGE 495

ADD 8 MOBILE PEDESTALS: \$4,552 — SEE PAGE 530

SEE PAGE 499 FOR BUNDLE SKU INFORMATION



Icon Legend on page 19

72"W Height Adjustable Typicals with 30"D Worksurfaces

QTY	DESCRIPTION	MODEL	LIST PRICE	PRICE EXTENSION
2	Worksurface, Edgeband, No Grommets 30" x 72"	HHAW3072PN	\$616	\$1,232
1	Height Adjustable Base	HMPHA2S4C	\$2,286	\$2,286
1	Height Adjustable Shared Trough 72"W	HMPHATROUGH72	\$479	\$479
2	Single-Sided Trough Lid	HMPHASLID72	\$138	\$276
1	End of Run Electrical Kit 72"W	HMPEEK72	\$214	\$214
1	Duplex 1	HH871501	\$43	\$43
1	Duplex 2	HH871502	\$43	\$43
1	Duplex 3	HH871503	\$43	\$43
1	Duplex 4	HH871504	\$43	\$43
TOTAL:				\$4,659

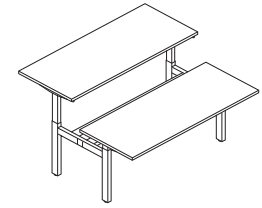

**2-PACK — 72"
72"W x 63"D**

QTY	DESCRIPTION	BUNDLE SKU	LIST PRICE
1	2-PACK BUNDLE Includes all Components Listed Above	HMPHA3072PK2	\$4,659

SPECIFYING EXAMPLE: Model.Laminate.Edgeband.BasePaint.TroughPaint.DuplexColor

NOTES: Typicals DO NOT include power in-feeds, screens, storage, or seating.

ADD 2 FABRIC SCREENS: \$1,454 — SEE PAGE 495

ADD 2 MOBILE PEDESTALS: \$1,138 — SEE PAGE 530

SEE PAGE 499 FOR BUNDLE SKU INFORMATION

QTY	DESCRIPTION	MODEL	LIST PRICE	PRICE EXTENSION
4	Worksurface, Edgeband, No Grommets 30" x 72"	HHAW3072PN	\$616	\$2,464
2	Height Adjustable Base	HMPHA2S4C	\$2,286	\$4,572
2	Height Adjustable Shared Trough 72"W	HMPHATROUGH72	\$479	\$958
4	Single-Sided Trough Lid	HMPHASLID72	\$138	\$552
1	Power Harness 72"W	HH871272	\$214	\$214
1	End of Run Electrical Kit 72"W	HMPEEK72	\$214	\$214
2	Duplex 1	HH871501	\$43	\$86
2	Duplex 2	HH871502	\$43	\$86
2	Duplex 3	HH871503	\$43	\$86
2	Duplex 4	HH871504	\$43	\$86
TOTAL:				\$9,318

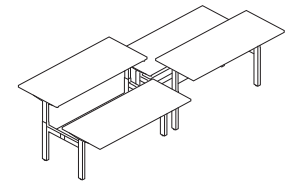

**4-PACK — 72"
144"W x 63"D**

QTY	DESCRIPTION	BUNDLE SKU	LIST PRICE
1	4-PACK BUNDLE Includes all Components Listed Above	HMPHA3072PK4	\$9,318

SPECIFYING EXAMPLE: Model.Laminate.Edgeband.BasePaint.TroughPaint.DuplexColor

NOTES: Typicals DO NOT include power in-feeds, screens, storage, or seating.

ADD 4 FABRIC SCREENS: \$2,908 — SEE PAGE 495

ADD 4 MOBILE PEDESTALS: \$2,276 — SEE PAGE 530

SEE PAGE 499 FOR BUNDLE SKU INFORMATION



QTY	DESCRIPTION	MODEL	LIST PRICE	PRICE EXTENSION
6	Worksurface, Edgeband, No Grommets 30" x 72"	HHAW3072PN	\$616	\$3,696
3	Height Adjustable Base	HMPHA2S4C	\$2,286	\$6,858
3	Height Adjustable Shared Trough 72"W	HMPHATROUGH72	\$479	\$1,437
6	Single-Sided Trough Lid	HMPHASLID72	\$138	\$828
2	Power Harness 72"W	HH871272	\$214	\$428
1	End of Run Electrical Kit 72"W	HMPEEK72	\$214	\$214
3	Duplex 1	HH871501	\$43	\$129
3	Duplex 2	HH871502	\$43	\$129
3	Duplex 3	HH871503	\$43	\$129
3	Duplex 4	HH871504	\$43	\$129
TOTAL:				\$13,977

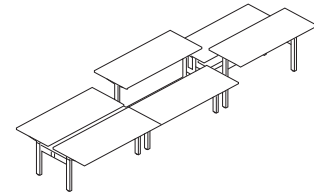

**6-PACK — 72"
216"W x 63"D**

QTY	DESCRIPTION	BUNDLE SKU	LIST PRICE
1	6-PACK BUNDLE Includes all Components Listed Above	HMPHA3072PK6	\$13,977

SPECIFYING EXAMPLE: Model.Laminate.Edgeband.BasePaint.TroughPaint.DuplexColor

NOTES: Typicals DO NOT include power in-feeds, screens, storage, or seating.

ADD 6 FABRIC SCREENS: \$4,362 — SEE PAGE 495

ADD 6 MOBILE PEDESTALS: \$3,414 — SEE PAGE 530

SEE PAGE 499 FOR BUNDLE SKU INFORMATION

QTY	DESCRIPTION	MODEL	LIST PRICE	PRICE EXTENSION
8	Worksurface, Edgeband, No Grommets 30" x 72"	HHAW3072PN	\$616	\$4,928
4	Height Adjustable Base	HMPHA2S4C	\$2,286	\$9,144
4	Height Adjustable Shared Trough 72"W	HMPHATROUGH72	\$479	\$1,916
8	Single-Sided Trough Lid	HMPHASLID72	\$138	\$1,104
3	Power Harness 72"W	HH871272	\$214	\$642
1	End of Run Electrical Kit 72"W	HMPEEK72	\$214	\$214
4	Duplex 1	HH871501	\$43	\$172
4	Duplex 2	HH871502	\$43	\$172
4	Duplex 3	HH871503	\$43	\$172
4	Duplex 4	HH871504	\$43	\$172
TOTAL:				\$18,636

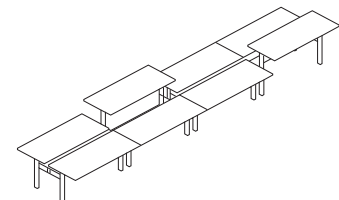

**8-PACK — 72"
288"W x 63"D**

QTY	DESCRIPTION	BUNDLE SKU	LIST PRICE
1	8-PACK BUNDLE Includes all Components Listed Above	HMPHA3072PK8	\$18,636

SPECIFYING EXAMPLE: Model.Laminate.Edgeband.BasePaint.TroughPaint.DuplexColor

NOTES: Typicals DO NOT include power in-feeds, screens, storage, or seating.

ADD 8 FABRIC SCREENS: \$5,816 — SEE PAGE 495

ADD 8 MOBILE PEDESTALS: \$4,552 — SEE PAGE 530

SEE PAGE 499 FOR BUNDLE SKU INFORMATION



Icon Legend on page 19

60"W Height Adjustable Typicals with 30"D Worksurfaces

QTY	DESCRIPTION	MODEL	LIST PRICE	PRICE EXTENSION
2	Worksurface, Edgeband, No Grommets 30" x 60"	HHAW3060PN	\$544	\$1,088
1	Height Adjustable Base	HMPHA2S4C	\$2,286	\$2,286
1	Height Adjustable Shared Trough 60"W	HMPHATROUGH60	\$436	\$436
2	Single-Sided Trough Lid	HMPHASLID60	\$126	\$252
1	End of Run Electrical Kit 60"W	HMPEEK60	\$214	\$214
1	Duplex 1	HH871501	\$43	\$43
1	Duplex 2	HH871502	\$43	\$43
1	Duplex 3	HH871503	\$43	\$43
1	Duplex 4	HH871504	\$43	\$43
TOTAL:				\$4,448

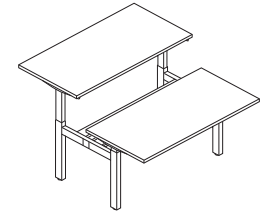

**2-PACK — 60"
60"W x 63"D**

QTY	DESCRIPTION	BUNDLE SKU	LIST PRICE
1	2-PACK BUNDLE Includes all Components Listed Above	HMPHA3060PK2	\$4,448

SPECIFYING EXAMPLE: Model.Laminate.Edgeband.BasePaint.TroughPaint.DuplexColor

NOTES: Typicals DO NOT include power in-feeds, screens, storage, or seating.

ADD 2 FABRIC SCREENS: \$1,312 — SEE PAGE 495

ADD 2 MOBILE PEDESTALS: \$1,138 — SEE PAGE 530

SEE PAGE 499 FOR BUNDLE SKU INFORMATION

QTY	DESCRIPTION	MODEL	LIST PRICE	PRICE EXTENSION
4	Worksurface, Edgeband, No Grommets 30" x 60"	HHAW3060PN	\$544	\$2,176
2	Height Adjustable Base	HMPHA2S4C	\$2,286	\$4,572
2	Height Adjustable Shared Trough 60"W	HMPHATROUGH60	\$436	\$872
4	Single-Sided Trough Lid	HMPHASLID60	\$126	\$504
1	Power Harness 60"W	HH871260	\$214	\$214
1	End of Run Electrical Kit 60"W	HMPEEK60	\$214	\$214
2	Duplex 1	HH871501	\$43	\$86
2	Duplex 2	HH871502	\$43	\$86
2	Duplex 3	HH871503	\$43	\$86
2	Duplex 4	HH871504	\$43	\$86
TOTAL:				\$8,896

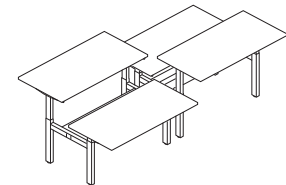

**4-PACK — 60"
120"W x 63"D**

QTY	DESCRIPTION	BUNDLE SKU	LIST PRICE
1	4-PACK BUNDLE Includes all Components Listed Above	HMPHA3060PK4	\$8,896

SPECIFYING EXAMPLE: Model.Laminate.Edgeband.BasePaint.TroughPaint.DuplexColor

NOTES: Typicals DO NOT include power in-feeds, screens, storage, or seating.

ADD 4 FABRIC SCREENS: \$2,624 — SEE PAGE 495

ADD 4 MOBILE PEDESTALS: \$2,276 — SEE PAGE 530

SEE PAGE 499 FOR BUNDLE SKU INFORMATION



QTY	DESCRIPTION	MODEL	LIST PRICE	PRICE EXTENSION
6	Worksurface, Edgeband, No Grommets 30" x 60"	HHAW3060PN	\$544	\$3,264
3	Height Adjustable Base	HMPHA2S4C	\$2,286	\$6,858
3	Height Adjustable Shared Trough 60"W	HMPHATROUGH60	\$436	\$1,308
6	Single-Sided Trough Lid	HMPHASLID60	\$126	\$756
2	Power Harness 60"W	HH871260	\$214	\$428
1	End of Run Electrical Kit 60"W	HMPEEK60	\$214	\$214
3	Duplex 1	HH871501	\$43	\$129
3	Duplex 2	HH871502	\$43	\$129
3	Duplex 3	HH871503	\$43	\$129
3	Duplex 4	HH871504	\$43	\$129
TOTAL:				\$13,344

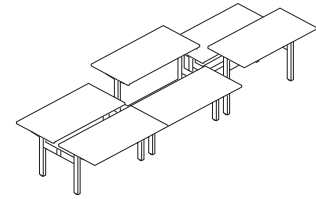

**6-PACK — 60"
180"W x 63"D**

QTY	DESCRIPTION	BUNDLE SKU	LIST PRICE
1	6-PACK BUNDLE Includes all Components Listed Above	HMPHA3060PK6	\$13,344

SPECIFYING EXAMPLE: Model.Laminate.Edgeband.BasePaint.TroughPaint.DuplexColor

NOTES: Typicals DO NOT include power in-feeds, screens, storage, or seating.

ADD 6 FABRIC SCREENS: \$3,936 — SEE PAGE 495

ADD 6 MOBILE PEDESTALS: \$3,414 — SEE PAGE 530

SEE PAGE 499 FOR BUNDLE SKU INFORMATION

QTY	DESCRIPTION	MODEL	LIST PRICE	PRICE EXTENSION
8	Worksurface, Edgeband, No Grommets 30" x 60"	HHAW3060PN	\$544	\$4,352
4	Height Adjustable Base	HMPHA2S4C	\$2,286	\$9,144
4	Height Adjustable Shared Trough 60"W	HMPHATROUGH60	\$436	\$1,744
8	Single-Sided Trough Lid	HMPHASLID60	\$126	\$1,008
3	Power Harness 60"W	HH871260	\$214	\$642
1	End of Run Electrical Kit 60"W	HMPEEK60	\$214	\$214
4	Duplex 1	HH871501	\$43	\$172
4	Duplex 2	HH871502	\$43	\$172
4	Duplex 3	HH871503	\$43	\$172
4	Duplex 4	HH871504	\$43	\$172
TOTAL:				\$17,792

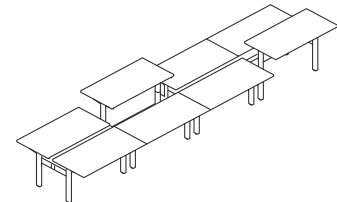

**8-PACK — 60"
240"W x 63"D**

QTY	DESCRIPTION	BUNDLE SKU	LIST PRICE
1	8-PACK BUNDLE Includes all Components Listed Above	HMPHA3060PK8	\$17,792

SPECIFYING EXAMPLE: Model.Laminate.Edgeband.BasePaint.TroughPaint.DuplexColor

NOTES: Typicals DO NOT include power in-feeds, screens, storage, or seating.

ADD 8 FABRIC SCREENS: \$5,248 — SEE PAGE 495

ADD 8 MOBILE PEDESTALS: \$4,552 — SEE PAGE 530

SEE PAGE 499 FOR BUNDLE SKU INFORMATION

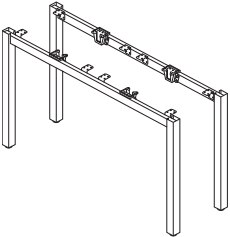
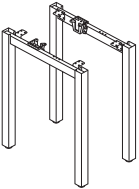
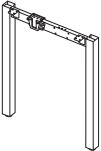

EMPOWER® Legs for Linear Applications

	DESCRIPTION	MODEL	SHIP WEIGHT	CUBE	LIST PRICE BY PAINT GRADE		
					P1	P2	P3
	Double Depth U-Leg (Box of 2) 50½"D for use with 24"D Worksurfaces 62½"D for use with 30"D Worksurfaces NOTES: Ships as a box of 2 legs.	HMPEL4828 HMPEL6028	32.4 34.8	14.9 18.5	\$1136 \$1249	\$1140 \$1253	\$1170 \$1286
	Double Depth Shared U-Leg (Singles) 30"D for use with 24"D Worksurfaces 42"D for use with 30"D Worksurfaces	HMPSL4828 HMPSL6028	21.1 22.5	4.9 6.4	\$468 \$514	\$472 \$518	\$482 \$529
	Single Depth U-Leg (Box of 2) 24"D for use with 24"D Worksurfaces 30"D for use with 30"D Worksurfaces	HMPPEL2428 HMPPEL3028	23.7 24.9	7.6 9.4	\$568 \$626	\$572 \$630	\$596 \$657
	Single Depth Shared U-Leg (Singles) 18"D for use with 24"D Worksurfaces 24"D for use with 30"D Worksurfaces	HMPPSL2428 HMPPSL3028	14.8 15.6	3.2 4.0	\$345 \$380	\$349 \$384	\$362 \$399
	Single Depth Return U-Leg (Singles) Left Right NOTES: Return U-Legs ship with two flat brackets.	HMPREL2428 HMPREL2428	23.7 23.7	4.0 4.0	\$345 \$345	\$349 \$349	\$362 \$362

HOW TO SPECIFY

Select Model Number H M P E L 4 8 2 8	Select Paint Color See page 464 T 1
---	--

EMPOWER® Legs for 120° Applications

GSA SIN 33721



Icon Legend on page 19

WORKSTATIONS

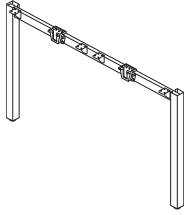

DESCRIPTION	MODEL	SHIP WEIGHT	CUBE	LIST PRICE BY PAINT GRADE		
				P1	P2	P3
Double Depth U-Leg (Single Leg for 120° Applications) 50½"D for use with 24"D Worksurfaces	HMP120EL4828	19	7.9	\$569	\$573	\$597
60½"D for use with 30"D Worksurfaces	HMP120EL6028	20	9.6	\$626	\$630	\$657

NOTES: Ships as single leg for 120 degree applications.

! 120 degree surfaces must be used in back-to-back applications — cannot be used freestanding.



DESCRIPTION	MODEL	SHIP WEIGHT	CUBE	P1	P2	P3
Post Leg for 120° Applications (Singles) 28½"H	HMP120POST	10	1.4	\$297	\$301	\$312

NOTES: One post leg needed per 120 degree worksurface. Post leg ships with attachment brackets needed to connect support beams and worksurfaces.

! 120 degree surfaces must be used in back-to-back applications — cannot be used freestanding.

Worksurface Width	Electrical Model	Quantity
36"	HH871124	1
36"	HH871148	2
42"	HH871124	1
42"	HH871160	2
48"	HH871124	1
48"	HH871172	2

HOW TO SPECIFY

Select Model Number

HMP120EL4828

Select Paint Color

See page 464

T1

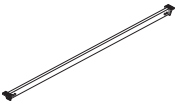
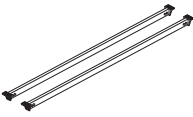
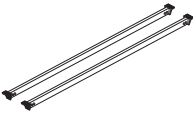

EMPOWER[®] Support Beams

	DESCRIPTION	MODEL	SHIP WEIGHT	CUBE	LIST PRICE
	Support Beams (Box of 1)				
	48"W	HMPUB148	7.0	0.5	\$286
	60"W	HMPUB160	8.3	0.7	\$319
	72"W	HMPUB172	9.6	0.9	\$353
	NOTES: One support beam per worksurface is needed. ⓘ Available in graphite finish only. No specification needed.				
	Support Beams (Box of 2)				
	48"W	HMPUB248	13.3	0.5	\$571
	60"W	HMPUB260	15.8	0.7	\$635
	72"W	HMPUB272	18.2	0.9	\$704
	NOTES: For use with double-sided stations. One support beam per worksurface is needed. ⓘ Available in graphite finish only. No specification needed.				
	Support Beams for 120° Applications (Box of 2)				
	36"W	HMP120UB236	7.8	0.9	\$452
	42"W	HMP120UB242	9.5	0.9	\$508
	48"W	HMP120UB248	11.0	0.9	\$571
	NOTES: Two support beams per 120 degree worksurface are needed. ⓘ Available in graphite finish only. No specification needed.				

NOTES:

- For use with stationary, single-sided stations. 36"W returns will use the 48"W Support Beam and 48"W returns will use the 60"W Support Beam.

HOW TO SPECIFY

Select Model Number

H M P 1 2 0 U B 2 3 6

EMPOWER® Wire Troughs

GSA SIN 33721



Icon Legend on page 19

WORKSTATIONS

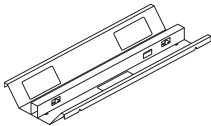
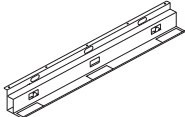
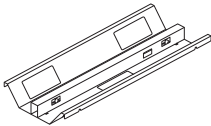
	DESCRIPTION	MODEL	SHIP WEIGHT	CUBE	LIST PRICE
	Trough — Double-Sided				
	48"W	HMPTROUGH48	3.3	5.3	\$396
	60"W	HMPTROUGH60	4.3	6.8	\$436
	72"W	HMPTROUGH72	5.3	8.3	\$479
	Available in graphite finish only. No specification needed.				
	Trough — Single-Sided				
	48"W	HMPSTROUGH48	3.0	5.3	\$296
	60"W	HMPSTROUGH60	4.0	6.8	\$402
	72"W	HMPSTROUGH72	5.0	8.3	\$508
	Available in graphite finish only. No specification needed.				
	Trough — Double-Sided for 120° Applications				
	36"W	HMP120TROUGH36	6.9	3.8	\$322
	42"W	HMP120TROUGH42	8.4	3.8	\$357
	48"W	HMP120TROUGH48	9.9	5.3	\$396
	Available in graphite finish only. No specification needed.				

NOTES:

- Slots available in trough to zip tie data cables to the trough.
- Double-sided wire trough rests on top of support bars. No fasteners needed.
- Single-sided trough is used for single-sided applications only. Screws into bottom side of worksurface for attachment.

For use with stationary Empower® only.

HOW TO SPECIFY

Select Model Number

H M P T R O U G H 4 8



EMPOWER® Return Components

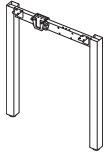

DESCRIPTION

Single Depth Return Leg (Singles)

Left
Right

NOTES: Return legs ship with two flat brackets.

MODEL	SHIP WEIGHT	CUBE	LIST PRICE BY PAINT GRADE		
			P1	P2	P3
HMPRELEL2428	23.7	4.0	\$345	\$349	\$362
HMPRRELEL2428	23.7	4.0	\$345	\$349	\$362

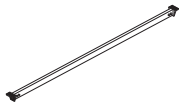

DESCRIPTION

Support Beams (Box of 1)

48"W
60"W

NOTES: For use with single-sided stations. 36"W returns will use the 48"W Support Beam and 48"W returns will use the 60"W Support Beam.

ⓘ Available in graphite finish only. No specification needed.

MODEL	SHIP WEIGHT	CUBE	LIST PRICE
HMPUB148	7.0	0.5	\$286
HMPUB160	8.3	0.7	\$319

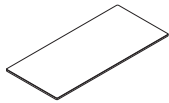

DESCRIPTION

24"D Worksurface with Edgeband

36"W x 24"D

NOTES: For use as a return surface only.

48"W x 24"D

NOTES: Can be used as a primary surface or a return surface.

MODEL	SHIP WEIGHT	CUBE	LIST PRICE BY LAMINATE GRADE	
			L1	L2
HWR2436PN	46 ⓘ	2.5	\$346	\$361
HWR2448PN	58 ⓘ	3.3	\$404	\$419

NOTES:

- Worksurfaces are constructed of laminate on 1/8" solid core high-performance particleboard.
- Return legs ship with two flat brackets. 36"W returns will use the 48"W Support Beam and 48"W returns will use the 60"W Support Beam.
- ⓘ All worksurfaces load tested to BIFMA standards.
- ⓘ Stack-on storage cannot be used on Empower® benching.
- ⓘ For use with static linear applications only.

HOW TO SPECIFY

<p>Select Model Number</p> <p>H M P R L E L 2 4 2 8 .</p>	<p>Select Paint Color</p> <p>See page 464</p> <p>T 1</p>	
<p>Select Model Number</p> <p>H W R 2 4 3 6 P N .</p>	<p>Select Laminate Color</p> <p>See page 464</p> <p>L D W 1 .</p>	<p>Select Edgeband Color</p> <p>See page 464</p> <p>L D W 1</p>

EMPOWER[®] Systems Worksurfaces

GSA SIN 33721



Icon Legend on page 19

WORKSTATIONS

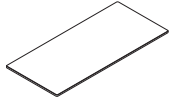

DESCRIPTION

24"D Worksurface with Edgeband

36"W x 24"D

NOTES: For use as a return surface only.

48"W x 24"D

NOTES: Can be used as a primary surface or a return surface.

60"W x 24"D

72"W x 24"D

NOTES: For use as a primary surface.

MODEL

HWR2436PN

HWR2448PN

HWR2460PN

HWR2472PN

SHIP WEIGHT

46 Ⓢ

58 Ⓢ

70

89

CUBE

2.5

3.3

4.0

4.8

LIST PRICE BY LAMINATE GRADE

L1

\$346

\$404

\$477

\$529

L2

\$361

\$419

\$497

\$549

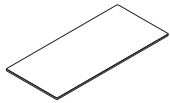

30"D Worksurface with Edgeband

48"W x 30"D

60"W x 30"D

72"W x 30"D

HWR3048PN

HWR3060PN

HWR3072PN

58 Ⓢ

70

89

3.3

4.0

4.8

\$436

\$520

\$593

\$451

\$540

\$613

NOTES:

- Worksurfaces are constructed of laminate on 1 1/8" solid core high-performance particleboard.

- ⓘ All worksurfaces load tested to BIFMA standards.
- ⓘ Stack-on storage cannot be used on Empower[®] benching.
- ⓘ Height adjustable worksurfaces are reduced 2" in width and 0.75" in depth to prevent pinch points.

HOW TO SPECIFY

Select Model Number

HWR2448PN

Select Laminate Color

See page 464

LDW1

Select Edgeband Color

See page 464

LDW1



SYSTEMS WORKSURFACES

120 Degree Corner

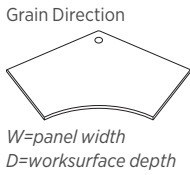

DESCRIPTION

Abound® and Accelerate® 120 Degree Corner Worksurfaces with Curved User Edge

36"W x 24"D
42"W x 24"D
48"W x 24"D

MODEL

HBWCT3624P
HBWCT4224P
HBWCT4824P

SHIP WEIGHT

75
96
107

CUBE

7.7
9.2
9.2

L1 LIST PRICE

\$777
\$833
\$965

L2 LIST PRICE

\$792
\$848
\$980

42"W x 30"D
48"W x 30"D

HBWCT4230P
HBWCT4830P

102
112

11.4
11.4

\$1094
\$1164

\$1109
\$1179

- HBWCT3624P will not accept the H4022, HE4022, H4028, or H4029 keyboard platforms.
- One small worksurface bracket standard with each worksurface.

❗ Corner worksurfaces must match exactly the panel behind them, i.e.: a 36" panel must be used on the back two sides of model HBWCT3624P.

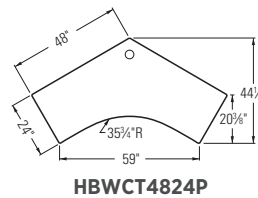
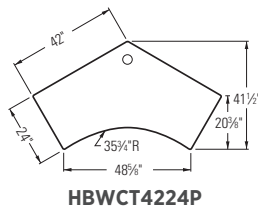
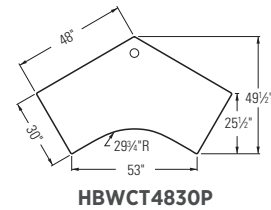
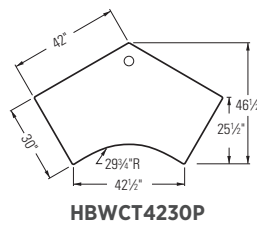
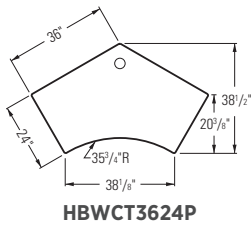

NOTES:

- Worksurfaces are constructed of laminate on 1/8" solid core high-performance particleboard.
- Add suffix "N" to Model Number for worksurfaces with no grommets. No upcharge.
- Refer to Worksurface Supports, pages 587-591.
- If used at an end of run, full end panel needs to be ordered — see page 587.

- ❗ Cannot use keyboard tray or full height pedestal under 120 degree corner worksurface.
- ❗ For use with linear applications only.

HOW TO SPECIFY

<p>Select Model Number</p> <p>No Grommet option: Add "N" suffix (no upcharge)</p> <p>HBWCT3624P .</p> <p>HBWCT3624PN .</p>	<p>Select Laminate</p> <p>See page 441</p> <p>AS .</p> <p>AS .</p>	<p>Select Edge Color</p> <p>See page 441</p> <p>K .</p> <p>K .</p>	<p>Select Grommet Color</p> <p>See page 441</p> <p>T1</p>
---	---	---	--

EMPOWER® Height Adjustable Bases

OPEN MARKET

Icon Legend on page 19

WORKSTATIONS

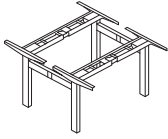

DESCRIPTION

Height Adjustable Base
Back-to-Back Workstation

MODEL

HMPHA2S4C

SHIP WEIGHT

130

CUBE

5.3

LIST PRICE

\$2286



DESCRIPTION

End of Run Kit
! End of Run Kit needs to be attached to one side of HMPHA2S4C. End of Run Kit cannot stand on its own.

MODEL

HMPHABEORKIT

15

3.1

\$176

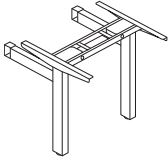

NOTES:

- Bases are steel construction with telescoping horizontal frame that adjusts from 41"-71"W to accommodate 42"-72"W worksurfaces. Memory controller features four memory presets, programmable upper and lower limit, and keypad lock to prevent unintentional movement. Dour motor with 250 lbs. load capacity per surface. Travel range of 19 5/8" adjustment from 25 5/8" to 45 1/4" (excluding worksurface dimension).
- ! Height adjustable benching cannot be single-sided; must always be used in back to back layouts.
- ! HBSMAUSB and HBDMAUSB cannot be used in Empower® height adjustable applications.

DESCRIPTION

Trough for Height Adjustable Base — Double-Sided
48"W
60"W
72"W

MODEL

HMPHATROUGH48
HMPHATROUGH60
HMPHATROUGH72

SHIP WEIGHT

5.0
6.5
7.0

CUBE

1.7
2.2
2.7

LIST PRICE

\$396
\$436
\$479

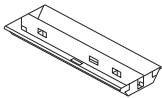

Trough for Height Adjustable End of Run
20"W

MODEL

HMPHATROUGH20

3.0

0.4

\$320

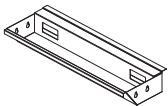

Single-Sided Trough Lid — Single Pack

For 48"W Trough
For 60"W Trough
For 72"W Trough
For Height Adjustable Base 20"W End of Run Trough

HMPHASLID48
HMPHASLID60
HMPHASLID72
HMPHASLID20

3.0
4.0
5.0
2.0

0.4
0.5
0.6
0.4

\$115
\$126
\$138
\$92

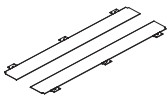

NOTES:

- Slots available in trough to zip tie data cables to the trough.
- Trough attaches to crossbeam connected to the height adjustable columns.
- 2 trough lids needed per double-sided trough.
- 1 trough lid needed for end of run trough.
- \$4 upcharge for P2 Paints.
- \$10 upcharge for P3 Paints on Trough Covers and End of Run Trough.
- \$20 upcharge for P3 Paints on Troughs.

HOW TO SPECIFY

Select Model Number H M P H A 2 S 4 C	Select Paint Color P71 Black P8L Nickel PD8 White P 8 L
---	--

Select Model Number H M P H A T R O U G H 4 8	Select Paint Color See page 464 P 8 S
---	--



Icon Legend on page 19

EMPOWER® Systems Worksurfaces

	DESCRIPTION	MODEL	SHIP WEIGHT	CUBE	LIST PRICE BY LAMINATE GRADE	
					L1	L2
	24"D Height Adjustable Worksurfaces					
	48"W x 24"D	HHAW2448PN	58	3.1	\$429	\$444
	60"W x 24"D	HHAW2460PN	70	3.9	\$499	\$519
	72"W x 24"D	HHAW2472PN	89	4.6	\$552	\$572
	30"D Height Adjustable Worksurfaces					
	48"W x 30"D	HHAW3048PN	68	3.9	\$458	\$473
	60"W x 30"D	HHAW3060PN	101	4.8	\$544	\$564
	72"W x 30"D	HHAW3072PN	105	5.7	\$616	\$636
	Half-Round Worksurfaces for End of Run					
	50"W x 30"D	HHAWD2450PN	54	4.8	\$618	\$633
	62"W x 30"D	HHAWD3062PN	77	5.9	\$720	\$740

OPEN MARKET

NOTES:

- Worksurfaces are constructed of laminate on 1 1/8" solid core high-performance particleboard.
- ! All worksurfaces load tested to BIFMA standards.
- ! Stack-on storage cannot be used on Empower® benching.
- ! Height adjustable worksurfaces are reduced 2" in width and 0.75" in depth to prevent pinch points.

HOW TO SPECIFY

<p>Select Model Number</p> <p>HHAW2448PN.</p>	<p>Select Laminate Color</p> <p>See page 464</p> <p>WHIT.</p>	<p>Select Edgeband Color</p> <p>See page 464</p> <p>WHIT</p>
--	--	---

EMPOWER® Side Screens

GSA SIN 33721



Icon Legend on page 19

WORKSTATIONS

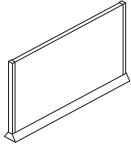

DESCRIPTION

Fabric Side Screen
24"D x 13"H
24"D x 20"H

30"D x 13"H
30"D x 20"H

MODEL

HMPDFS2413
HMPDFS2420

HMPDFS3013
HMPDFS3020

SHIP WEIGHT CUBE

4.5 2.1
4.5 1.6

5.0 1.9
5.0 2.2

LIST PRICE BY FABRIC GRADE

AA A B

\$399 \$419 \$439
\$440 \$460 \$480

\$439 \$459 \$479
\$484 \$504 \$524

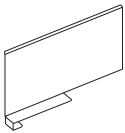

DESCRIPTION

Painted Metal Side Screen
24"D x 13"H
30"D x 13"H

MODEL

HMPDMS2413
HMPDMS3013

SHIP WEIGHT CUBE

6.3 2.0
7.7 2.8

LIST PRICE BY PAINT GRADE

P1 P2 P3

\$280 \$284 \$300
\$321 \$325 \$341

NOTES:

- Fabric screen adheres to the top of the worksurface with heavy-duty double stick tape.
- Metal screen slides over the edge of the worksurface and screws in under the worksurface.
- Metal screen is available in paint.
- For use on stationary and height adjustable setups.

HOW TO SPECIFY

<p>Select Model Number</p> <p>H M P D F S 2 4 1 3 .</p>	<p>Select Paint Color</p> <p>See page 464</p> <p>T 1 .</p>	<p>Select Fabric</p> <p>See pages 462-463</p> <p>A P N 1 1</p>
<p>Select Model Number</p> <p>H M P D M S 2 4 1 3 .</p>	<p>Select Paint Color</p> <p>See page 464</p> <p>P 8 S</p>	



Icon Legend on page 19

EMPOWER[®] Center Screens Fabric

WORKSTATIONS

	DESCRIPTION	MODEL	SHIP WEIGHT	CUBE	LIST PRICE BY FABRIC GRADE			
					AA	A	B	
	Fabric Screens (Shared) — 13”H							
	24”W	HMPCFS2413	6.3	0.9	\$299	\$319	\$339	
	30”W	HMPCFS3013	7.3	1.1	\$372	\$392	\$412	
	36”W	HMPCFS3613	8.3	1.4	\$453	\$473	\$493	
	42”W	HMPCFS4213	9.3	1.6	\$466	\$486	\$506	
	48”W	HMPCFS4813	10.3	1.8	\$577	\$597	\$617	
	60”W	HMPCFS6013	12.3	2.3	\$663	\$683	\$703	
	❗ For use on stationary stations only.							
		Fabric Screens (Shared) — 20”H						
		24”W	HMPCFS2420	7.3	1.6	\$381	\$401	\$421
30”W		HMPCFS3020	8.5	1.6	\$475	\$495	\$515	
36”W		HMPCFS3620	9.8	2.1	\$578	\$598	\$618	
42”W		HMPCFS4220	11.0	2.4	\$554	\$574	\$594	
48”W		HMPCFS4820	12.3	2.8	\$656	\$676	\$696	
60”W		HMPCFS6020	14.8	3.5	\$727	\$747	\$767	
❗ For use on stationary stations only.								
		Fabric Screens (Single) — 13”H						
		36”W	HMPFSS3613	9.7	2.4	\$448	\$468	\$488
	42”W	HMPFSS4213	11.0	1.7	\$461	\$481	\$501	
	48”W	HMPFSS4813	12.3	2.9	\$572	\$592	\$612	
	54”W	HMPFSS5413	13.6	2.4	\$600	\$620	\$640	
	60”W	HMPFSS6013	14.8	3.6	\$658	\$678	\$698	
OPEN MARKET	NOTES: For use on single-sided stationary stations or height adjustable stations (one per worksurface).							
	Fabric Screens (Single) — 20”H							
	36”W	HMPFSS3620	11.2	3.2	\$573	\$593	\$613	
	42”W	HMPFSS4220	12.8	2.7	\$549	\$569	\$589	
	48”W	HMPFSS4820	14.3	4.0	\$651	\$671	\$691	
	54”W	HMPFSS5420	15.9	3.6	\$682	\$702	\$722	
	60”W	HMPFSS6020	17.3	4.9	\$722	\$742	\$762	
OPEN MARKET	NOTES: For use on single-sided stationary stations or height adjustable stations (one per worksurface).							

NOTES:

- ❗ Only single-sided screens can be specified with height adjustable workstations.
- ❗ When using a power pole, the screen on the station with the pole must be 6” shorter to allow space for the pole to be mounted.

Fabric Screen Specifying Guide

Static Rectangle Worksurface Width	Inset 6” on Each Side	Full Length
48”	36”	48”
60”	48”	60”
72”	60”	N/A

120 Side Width	Inset 6” on Each Side	Full Length
36”	24”	36”
42”	30”	42”
48”	36”	48”

Height Adjustable Rectangle Worksurface Width	Inset 5” on Each Side	Inset 2” on Each Side
48” (undersized)	36”	42”
60” (undersized)	48”	54”
72” (undersized)	60”	N/A

HOW TO SPECIFY

<p>Select Model Number</p> <p>H M P C F S 3 6 2 0 .</p>	<p>Select Paint Color</p> <p>See page 464 \$4 upcharge for P2 Paints \$20 upcharge for P3 Paints</p> <p>T 1 .</p>	<p>Select Fabric</p> <p>See pages 462-463</p> <p>A P N 1 1</p>
--	--	---

EMPOWER[®] Center Screens Frosted Glass

GSA SIN 33721



Icon Legend on page 19

WORKSTATIONS

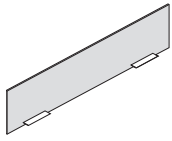

DESCRIPTION

Frosted Glass Screens (Shared) — 13”H

DESCRIPTION	MODEL	SHIP WEIGHT	CUBE	LIST PRICE BY PAINT GRADE	
				P1	P2
24”W	HMPFG2413	18.2	1.4	\$329	\$333
30”W	HMPFG3013	21.0	1.6	\$408	\$412
36”W	HMPFG3613	23.8	1.9	\$497	\$501
42”W	HMPFG4213	26.5	2.2	\$514	\$518
48”W	HMPFG4813	29.3	2.4	\$608	\$612
60”W	HMPFG6013	35.3	3.0	\$728	\$732
72”W	HMPFG7213	43.3	3.5	\$800	\$804

! For use on stationary stations only.

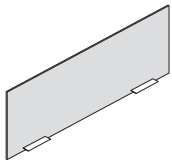

Frosted Glass Screens (Shared) — 20”H

24”W	HMPFG2420	24.8	2.0	\$417	\$421
30”W	HMPFG3020	28.8	2.4	\$520	\$524
36”W	HMPFG3620	32.8	2.8	\$608	\$612
42”W	HMPFG4220	37.3	3.1	\$609	\$613
48”W	HMPFG4820	41.3	3.5	\$719	\$723
60”W	HMPFG6020	49.3	4.3	\$799	\$803
72”W	HMPFG7220	60.3	5.1	\$878	\$882

! For use on stationary stations only.

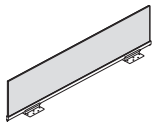

Frosted Glass Screens (Single) — 13”H

36”W	HMPFGS3613	25.2	1.9	\$492	\$496
42”W	HMPFGS4213	28.3	2.2	\$509	\$513
48”W	HMPFGS4813	31.3	2.4	\$603	\$607
54”W	HMPFGS5413	34.4	2.8	\$660	\$664
60”W	HMPFGS6013	37.8	3.0	\$723	\$727
72”W	HMPFGS7213	46.3	3.5	\$795	\$799

NOTES: For use on single-sided stationary stations or height adjustable stations (one per worksurface).

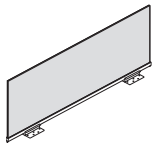

Frosted Glass Screens (Single) — 20”H

36”W	HMPFGS3620	34.2	2.8	\$603	\$607
42”W	HMPFGS4220	38.8	3.1	\$604	\$608
48”W	HMPFGS4820	43.3	3.5	\$714	\$718
54”W	HMPFGS5420	47.9	3.8	\$751	\$755
60”W	HMPFGS6020	51.8	4.3	\$794	\$798
72”W	HMPFGS7220	63.3	5.1	\$873	\$877

NOTES: For use on single-sided stationary stations or height adjustable stations (one per worksurface).

! 20”H glass cannot be used on 24”D single-sided stations.

NOTES:

- ! Only single-sided screens can be specified with height adjustable workstations.
- ! When using a power pole, the screen on the station with the pole must be 6” shorter to allow space for the pole to be mounted.

Glass Screen Specifying Guide

Rectangle Worksurface Width	Inset 6” on Each Side	Full Length
48”	36”	48”
60”	48”	60”
72”	60”	72”

120 Side Width	Inset 6” on Each Side	Full Length
36”	24”	36”
42”	30”	42”
48”	36”	48”

Height Adjustable Rectangle Worksurface Width	Inset 5” on Each Side	Inset 2” on Each Side
48” (undersized)	36”	42”
60” (undersized)	48”	54”
72” (undersized)	60”	N/A

HOW TO SPECIFY

Select Model Number H M P F G 3 6 1 3 .	Select Paint Color See page 464 T 1 .	Select Frosted Glass R Frosted Glass R
---	--	---



Icon Legend on page 19

Modesty Panels/End of Run Screens

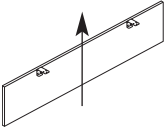
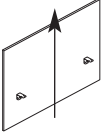
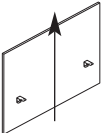
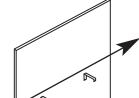
DESCRIPTION	MODEL	SHIP WEIGHT	CUBE	LIST PRICE BY LAMINATE GRADE	
				L1	L2
 <p>Laminate Modesty Panels — 13”H 36”W for use with 48”W Worksurfaces 48”W for use with 60”W Worksurfaces 60”W for use with 72”W Worksurfaces</p> <p>NOTES: Vertical grain. ⓘ For use on single-sided stationary Empower® only.</p>	HMPLM3613	12.9	1.9	\$181	\$191
	HMPLM4813	16.9	2.4	\$272	\$282
	HMPLM6013	19.9	2.9	\$311	\$321
 <p>Single-Side Laminate End of Run Screens Single — 24”W x 26”H Single — 24”W x 34”H Single — 30”W x 26”H Single — 30”W x 34”H</p> <p>NOTES: 24”W and 48”W models used on 24”D Worksurfaces and 30”W and 60”W models are used on 30”D Worksurfaces. Vertical grain.</p>	HMPLM2426	16.9	2.2	\$184	\$194
	HMPLM2434	20.9	2.8	\$201	\$211
	HMPLM3026	20.5	2.7	\$209	\$219
	HMPLM3034	25.5	3.4	\$231	\$241
 <p>Double-Side Laminate End of Run Screens Double — 48”W x 26”H Double — 48”W x 34”H Double — 60”W x 26”H Double — 60”W x 34”H</p> <p>NOTES: 24”W and 48”W models used on 24”D Worksurfaces and 30”W and 60”W models are used on 30”D Worksurfaces. Vertical grain.</p>	HMPLM4826	30.9	4.1	\$269	\$279
	HMPLM4834	38.9	5.2	\$295	\$305
	HMPLM6026	38.1	5.1	\$363	\$373
	HMPLM6034	48.3	6.4	\$394	\$404
 <p>Double-Side Laminate Gallery Panel for Height Adjustable 48”W x 50”H 60”W x 50”H</p> <p>NOTES: Horizontal grain.</p>	HMPLGP4850	82.0	6.6	\$614	\$624
	HMPLGP6050	100.0	9.2	\$682	\$692

OPEN MARKET

NOTES:

- End of run screens sit -1” inset on each side of the depth of the run.
- Static end of run screens are 13” below the surface and either 13”H or 20”H above the surface.
- Height adjustable end of run screens extend to the floor and are 50”H.

HOW TO SPECIFY

<p>Select Model Number</p> <p>HMPLM3613</p>	<p>Select Laminate Color</p> <p>See page 464</p> <p>PINCPINC</p>	<p>Select Paint Color</p> <p>Bracket paint must be specified</p> <p>T1</p>
--	---	---

EMPOWER[®] Typicals

GSA SIN 33721



Icon Legend on page 19

WORKSTATIONS

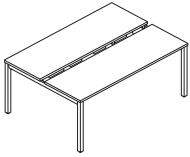
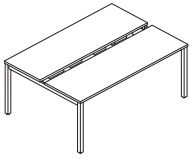
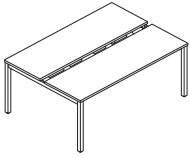
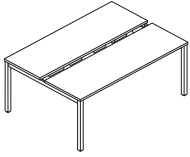
	DESCRIPTION	MODEL	SHIP WEIGHT	CUBE	LIST PRICE BY LAMINATE GRADE	
					L1	L2
	Bundles — 72" W with 24" D Worksurfaces					
	2-Pack	HMP2472PK2	238.9	35.3	\$3763	\$3803
	4-Pack	HMP2472PK4	465.8	59.4	\$6858	\$6938
	6-Pack	HMP2472PK6	692.7	83.9	\$9953	\$10073
	8-Pack	HMP2472PK8	919.6	108.5	\$13048	\$13208
	Bundles — 60" W with 24" D Worksurfaces					
	2-Pack	HMP2460PK2	198.9	35.3	\$3547	\$3587
	4-Pack	HMP2460PK4	385.8	59.4	\$6426	\$6506
	6-Pack	HMP2460PK6	572.7	83.9	\$9305	\$9425
	8-Pack	HMP2460PK8	759.6	108.5	\$12184	\$12344
	Bundles — 72" W with 30" D Worksurfaces					
	2-Pack	HMP3072PK2	238.9	35.3	\$4004	\$4044
	4-Pack	HMP3072PK4	465.8	59.4	\$7273	\$7353
	6-Pack	HMP3072PK6	692.7	83.9	\$10542	\$10662
	8-Pack	HMP3072PK8	919.6	108.5	\$13811	\$13971
	Bundles — 60" W with 30" D Worksurfaces					
	2-Pack	HMP3060PK2	198.9	35.3	\$3746	\$3786
	4-Pack	HMP3060PK4	385.8	59.4	\$6757	\$6837
	6-Pack	HMP3060PK6	572.7	83.9	\$9768	\$9888
	8-Pack	HMP3060PK8	759.6	108.5	\$12779	\$12939
SPECIFYING EXAMPLE: Model.Laminate.Edgeband.Paint2.DuplexColor (S only)						

NOTES:

- Bundles include worksurfaces, support legs, support bars, wire management troughs, harnesses, and duplexes.
- Please specify in-feed, screens, storage, and seating separately.

ⓘ Stack-on storage cannot be used on Empower benching.

HOW TO SPECIFY

<p>Select Model Number</p> <p>HMP2472PK2</p>	<p>Select Laminate Color</p> <p>See page 464</p> <p>LDW1</p>	<p>Select Edgeband Color</p> <p>See page 464</p> <p>LDW1</p>	<p>Select Paint Color</p> <p>See page 464</p> <p>\$4 upcharge for P2 Paints</p> <p>T1</p>	<p>Select Duplex Color</p> <p>See page 464</p> <p>S</p>
---	---	---	--	--



EMPOWER® Height Adjustable Typicals

	DESCRIPTION	MODEL	SHIP WEIGHT	CUBE	LIST PRICE BY LAMINATE GRADE	
					L1	L2
	Bundles — 72" W with 24" D Worksurfaces					
	2-Pack	HMPHA2472PK2	331	19.1	\$4531	\$4571
	4-Pack	HMPHA2472PK4	662	37.6	\$9062	\$9142
	6-Pack	HMPHA2472PK6	993	56.2	\$13593	\$13713
	8-Pack	HMPHA2472PK8	1324	74.7	\$18124	\$18284
	Bundles — 60" W with 24" D Worksurfaces					
	2-Pack	HMPHA2460PK2	291	16.9	\$4358	\$4398
	4-Pack	HMPHA2460PK4	581	33.1	\$8716	\$8796
	6-Pack	HMPHA2460PK6	872	49.4	\$13074	\$13194
	8-Pack	HMPHA2460PK8	1162	65.7	\$17432	\$17592
	Bundles — 72" W with 30" D Worksurfaces					
	2-Pack	HMPHA3072PK2	363	21.3	\$4659	\$4699
	4-Pack	HMPHA3072PK4	726	41.9	\$9318	\$9398
	6-Pack	HMPHA3072PK6	1089	62.6	\$13977	\$14097
	8-Pack	HMPHA3072PK8	1452	83.3	\$18636	\$18796
	Bundles — 60" W with 30" D Worksurfaces					
	2-Pack	HMPHA3060PK2	353	18.7	\$4448	\$4488
	4-Pack	HMPHA3060PK4	705	36.7	\$8896	\$8976
	6-Pack	HMPHA3060PK6	1058	54.8	\$13344	\$13464
	8-Pack	HMPHA3060PK8	1410	72.9	\$17792	\$17952

SPECIFYING EXAMPLE: Model.Laminate.Edgeband.BasePaint.TroughPaint.DuplexColor

NOTES:

- Bundles include worksurfaces, wire management troughs, trough covers, harnesses, duplexes, and bases.
- Please specify in-feed, screens, storage, and seating separately.

- ! Stack-on storage cannot be used on Empower benching.
- ! HBSMAUSB and HBDMAUSB cannot be used in Empower® height adjustable applications.

HOW TO SPECIFY

<p>Select Model Number</p> <p>H M P H A 2 4 7 2 P K 2</p>	<p>Select Laminate Color</p> <p>See page 464</p> <p>L D W 1</p>	<p>Select Edgeband Color</p> <p>See page 464</p> <p>L D W 1</p>	<p>Select Base Paint Color</p> <p>See page 464</p> <p>Upcharge for P2 and P3 Paints</p> <p>T 1</p>	<p>Select Trough Paint Color</p> <p>See page 464</p> <p>S</p>	<p>Select Duplex Color</p> <p>See page 464</p> <p>S</p>
---	---	---	--	---	---

EMPOWER[®] ELECTRICAL SPECIFYING INFORMATION

To Order:

1. Determine which electrical system you will use after consulting your electrician and computer support personnel:

- **The Four-circuit system (4-Hot/2-Neutral/2-Ground)**
 - 3 + 1 option
 - 2 + 2 option
- **The Three-circuit system (3-Hot/3-Neutral/2-Ground)**

2. Determine location, quantity and circuit of duplexes.
3. Determine the appropriate choice and use of Isolated, Isolated/Dedicated and Separate Neutral circuits.
4. Specify appropriate Power Harnesses* and Pass-Thru Cables.*
5. Determine the location, quantity and type of Power In-feed needed.

* Select Power Harness models (HH8712XX) and Pass-Thru Cables (HH8711XX) with the last two digits being the same as the associated worksurface width.

Electrical System Options

The four-circuit, eight-wire electrical system is widely specified and trusted by hundreds of thousands of end-users. This proven system delivers four circuits for every power in-feed in either a 3 + 1 or 2 + 2 configuration. The isolated/dedicated circuits are ideal for sensitive computing equipment, while the common circuits are suitable for faxes, copiers, task lights and other peripherals.

Both the 3 + 1 and 2 + 2 systems use the same pre-wired components, making it easy to adjust as electrical needs change.

You can also choose a three-circuit, eight-wire system that has a dedicated neutral for every hot circuit. The three-circuit components have model numbers with an "A" suffix and appear in a gray box in this pricer.

Four-circuit, 3 + 1 Receptacle Option

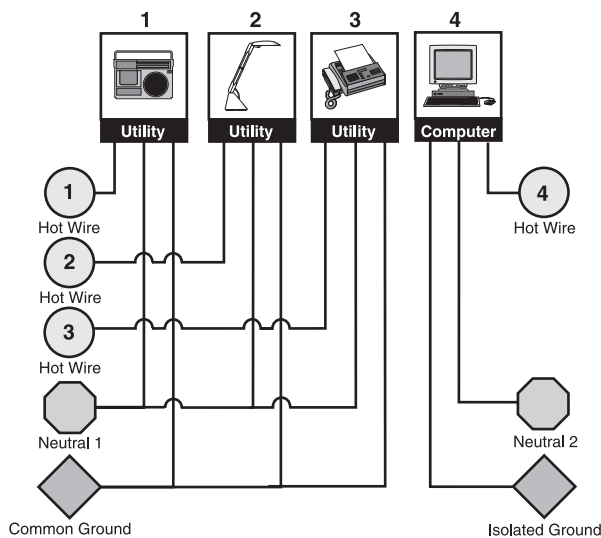

The 3 + 1 option is the electrical standard used by The HON Company for many years in most of their systems products. This wiring option provides three utility circuits plus an isolated/dedicated circuit for more sensitive equipment.

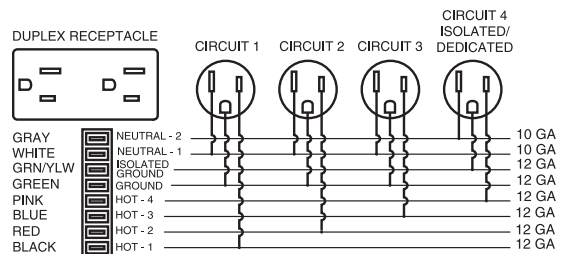

Four-circuit, 2 + 2 Receptacle Option

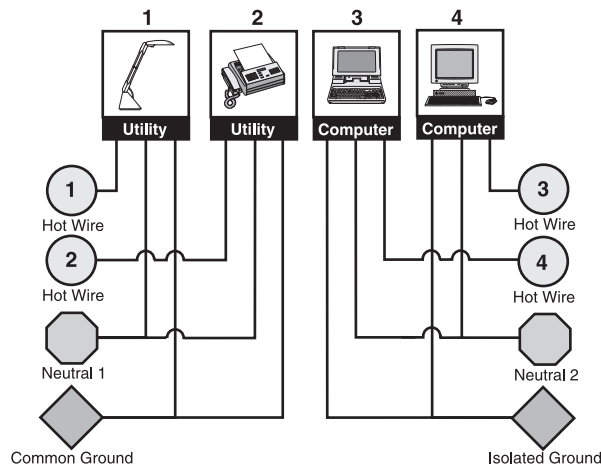

The 2 + 2 option is a wiring option that provides two utility circuits and two isolated circuits for more extensive computer usage applications.

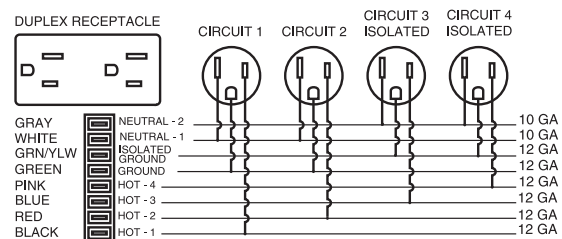

EMPOWER® ELECTRICAL SPECIFYING INFORMATION

Three-circuit, separate neutrals

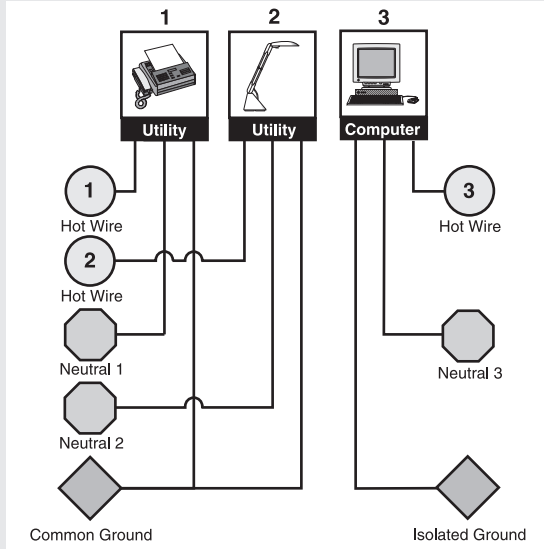

The Three-circuit, separate neutrals configuration is a wiring option that provides separate neutrals for each of the three circuits. Two circuits share a common ground, and one circuit is isolated/dedicated. The three-circuit components have model numbers with an "A" suffix and appear in a gray box in this price.

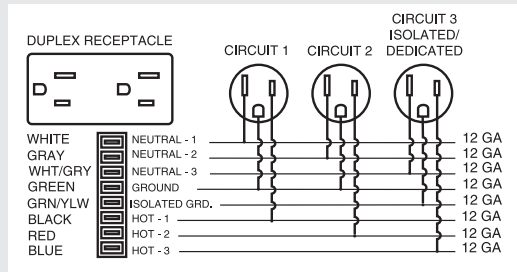

Two 8-wire, 20 AMP (15 AMP Canadian) electrical systems are offered					
Electrical System	Circuitry	Receptacle Capacity			
Four-circuit 4-Hot/2-Neutral/2-Ground (10 gauge neutral wires)	3 + 1	Common Circuit-1 HH873501	Common Circuit-2 (1) HH873502	Common Circuit-3 HH873503	Iso/Dedicated Circuit-4 HH873504
	2 + 2	Common Circuit-1 HH873501	Common Circuit-2 HH873502	Isolated Circuit-3 HH873506	Isolated Circuit-4 HH873504
Three-circuit 3-Hot/3-Neutral/2-Ground (12 gauge neutral wires)	w/separate neutrals	Common Circuit-1 HH873501A	Common Circuit-2 HH873502A	Iso/Dedicated Circuit-3 HH873503A	N/A

(1) Circuit-2 (one of the 3 common circuits sharing a neutral wire) cannot be used with a single-phase building electrical supply.

Notes:

- Four-circuit components and three-circuit components (with suffix "A") cannot be used together.
- Components of the two systems are keyed differently to prevent components of one system from being connected to components of another system.
- HON Cat. Nos. are printed on the UL labels, and components are color-coded to provide visual identification of the different components.
- Four-circuit components have black plastic parts.
- Three-circuit components have rust-colored terminal ends and receptacle backs are rust colored.

Typical power usage by the most commonly specified office equipment.

Source: Industry Analysis, Inc., Rochester, NY

EQUIPMENT	AMPS	EQUIPMENT	AMPS	EQUIPMENT	AMPS
Computers		Copiers		FAX Machines	
Personal Computer	3	Desktop Copier	15	InkJet FAX	less than 1
Notebook Computer	3	Console Copier	20	Thermal FAX	less than 1
		Copier/Duplicator	30	Plain paper FAX	8
Monitors		Printers		Task Lights	
13" Color Monitor	2	Dot Matrix	less than 1	36" T8 Fluorescent	0.2/bulb
17" Color Monitor	3	InkJet	less than 1	48" T8 Fluorescent	0.3/bulb
21" Color Monitor	4	Personal Laser or LED	8		
		Workgroup Laser or LED	15		

Duplex Receptacles



15 AMP Receptacle

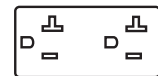

20 AMP Receptacle
(Required by some large copiers.)

EMPOWER[®] ELECTRICAL SPECIFYING INFORMATION

- Electrical components are UL Listed and CSA Certified.
- It is the customer's responsibility to ensure that use of the pre-wired electrical system, the number of receptacles used on a given circuit, and connection to a building power source, be in compliance with all local and national electrical codes.
- Contact Customer Service for additional information.
- Four-circuit components and Three-circuit components (with suffix "A") cannot be used together. See pages 500-501.
- ! A licensed electrician must make connections to a building electrical supply.

Definition of components:

Electrical Power Harness



- Used to distribute power in workstations.
- Power distribution in either direction.
- Specify Power Harness to match workstation width.
- Double-sided: receptacles can be inserted into both sides of Power Blocks.

Electrical Pass-Thru Cables

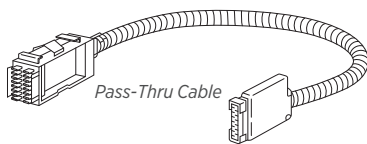

Pass-Thru Cable With Duplex Capacity:

- Use in workstations where multiple receptacles are not required.
- Added feature: has capacity for one receptacle on each side of a workstation. Feature offers future expansion and is an alternative to Power Harnesses.

Duplex Receptacles

- 15 amp outlet configuration.
- Models HH871601 and HH871601A have a 20 amp outlet configuration.
- Fit back-to-back into the Power Block(s) of Power and Pass-Thru Harnesses.
- Labeled with the provided circuit. Circuits connected to the Isolated Ground are identified with an orange triangle; circuits that do not share a neutral or ground have an orange circuit number.

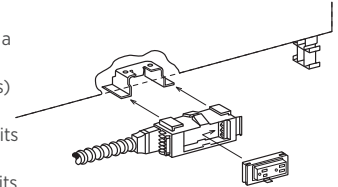

Power In-Feed Model (Floor or Ceiling) HMP144

- Used to connect the workstation electrical system to the building electrical supply.
- ! A licensed electrician must make connections to a building electrical supply.
- ! Conduit is UL listed Black Liquid-tight conduit (outside diameter is 7/8").

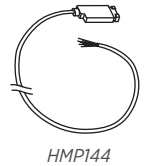

Note: In-feed cables listed above may be field-cut to desired length.

3-Pack 120 Degree Electric Specification Guide

	A	B
36" 120 surface	HH871124	HH871148
42" 120 surface	HH871124	HH871160
48" 120 surface	HH871124	HH871172

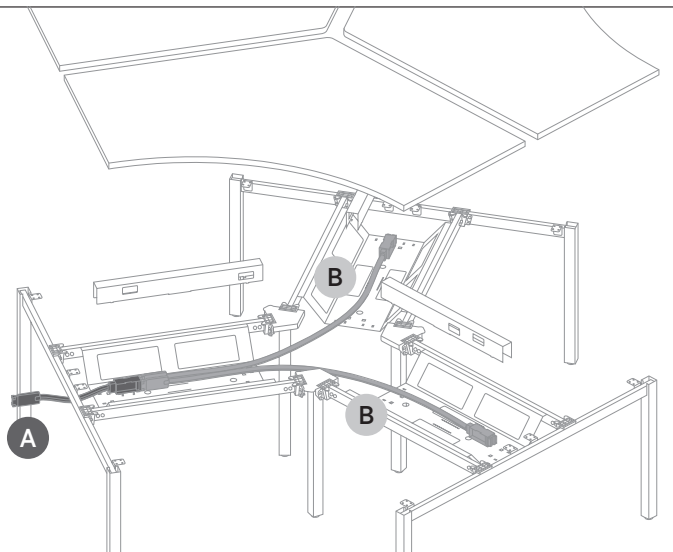

EMPOWER[®] ELECTRICAL SPECIFYING INFORMATION

- Electrical components are UL Listed and CSA Certified.
- It is the customer's responsibility to ensure that use of the pre-wired electrical system, the number of receptacles used on a given circuit, and connection to a building power source, be in compliance with all local and national electrical codes.
- ! A licensed electrician must make connections to a building electrical supply.

Vertebrae:
17 Cables, 0.250 Diameter (CAT-6)

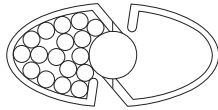

Single-Depth Cable Trough Cover Capacity:
13 Cables, 0.250 Diameter (CAT-6)

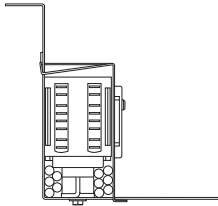

Double-Depth Cable Trough Cover Capacity:
14 Cables, 0.250 Diameter (CAT-6)

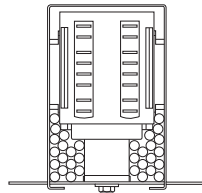

Data Cable Packing in Power Pole:
33 Cables, 0.250 Diameter (CAT-6)

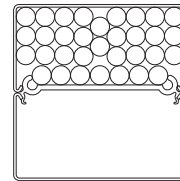

Data Cable Packing in Wire Trough Cover:
14 Cables, 0.250 Diameter (CAT-6)

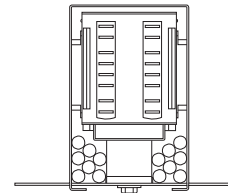

EMPOWER[®] Electrical and Data

GSA SIN 33721 EXCEPT AS NOTED



Icon Legend on page 19

WORKSTATIONS

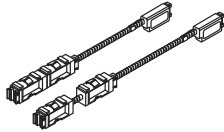
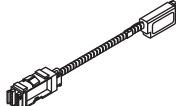
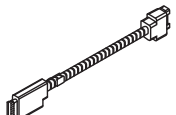
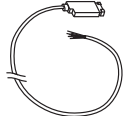
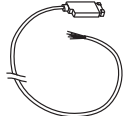
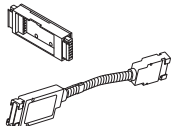

	DESCRIPTION	MAX. RECEPT. CAP. PER PANEL SIDE	MODEL		SHIP WEIGHT	CUBE	LIST PRICE
			FOUR-CIRCUIT 3 + 1 2 + 2	THREE-CIRCUIT, SEPARATE NEUTRALS			
	Electrical Power Harnesses, Frames — w/duplex capacity						
	For 48"W	2	HH871248	HH871248A	3.0 Ⓢ	0.5	\$214
	For 60"W	2	HH871260	HH871260A	3.0 Ⓢ	0.5	\$214
	For 72"W	2	HH871272	HH871272A	5.0 Ⓢ	0.5	\$214
	Electrical Pass-Thru Cables, Frames — w/duplex capacity						
	For 48"W	1	HH871148	HH871148A	2.5 Ⓢ	0.5	\$134
	For 60"W	1	HH871160	HH871160A	3.0 Ⓢ	0.5	\$134
	For 72"W	1	HH871172	HH871172A	5.0 Ⓢ	0.5	\$134
	Electrical Pass-Thru Harness without Power Block						
	For 24"W Frames	0	HH871024	HH871024A	2.0 Ⓢ	0.5	\$118
	For 48"W Frames	0	HH871048	HH871048A	3.0 Ⓢ	0.5	\$123
	For 60"W Frames	0	HH871060	HH871060A	3.0 Ⓢ	0.5	\$123
	For 72"W Frame Runs	0	HH871072		4.0 Ⓢ	0.5	\$170
<p>! 24" Pass-Thru Harness without Power Block is only used when specifying Power In-Feed with Sealtight as a floor in-feed. Harness is not needed for the standard in-feed.</p>							
	Power In-Feed — Sealtight						
	144" long conduit, Sealtight Cable — 7/8" diameter		HMP144		7.0	1.2	\$331
<p>NOTES: For use as ceiling, floor and wall in-feed. If three-circuit, separate neutral in-feed is required, please contact Tailored Solutions.</p>							
	Metal Flexible Conduit						
	144" long conduit, Flex Cable — 7/8" dia.		HH871912		4.0 Ⓢ	0.5	\$235
<p>NOTES: Metal Flexible Conduit. Best option for use with power pole due to bend radius flexibility.</p>							
	Power Jumper						
	For End of Run		HMPJUMP		2.0	0.3	\$168
<p>OPEN MARKET</p>							

HOW TO SPECIFY

Select
Model Number

HH871248

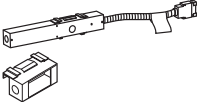

DESCRIPTION	MODEL		SHIP WEIGHT	CUBE	LIST PRICE
	FOUR-CIRCUIT 3 + 1 2 + 2	THREE-CIRCUIT, SEPARATE NEUTRALS			
 Hardwire Applications Hardwire Power In-feed ⚠ Customer to furnish all cabling and wiring from power entry to power source (approved for use by city of New York).	HH871400	HH871400A	4.0 Ⓞ	0.3	\$222
Hardwire Junction Box (6-pack) ⚠ Hardwire Junction Boxes cannot be installed back-to-back in panel applications.	HH871500		4.5 Ⓞ	0.1	\$472
 Each marked with Circuit Number	Duplex Receptacles				
Circuit 1	HH871501	HH871501A	1.0 Ⓞ	0.5	\$43
Circuit 2	HH871502	HH871502A	1.0 Ⓞ	0.5	\$43
Circuit 3 (except 2 + 2 — see below)	HH871503	HH871503A	1.0 Ⓞ	0.5	\$43
Circuit 4 — isolated, dedicated circuit	HH871504		1.0 Ⓞ	0.5	\$43
Circuit 1 (20 amp outlet configuration)	HH871601		1.0 Ⓞ	0.5	\$43
Circuit 3 (2 + 2)	HH871506		1.0 Ⓞ	0.5	\$43
Specify Paint. Charcoal (S) matches Empower trough.					

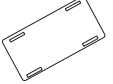
DESCRIPTION	MODEL	SHIP WEIGHT	CUBE	LIST PRICE
 Receptacle Cover Replacements Quantity 25 ⚠ Specify Color—Available in Black (P), Muslin (T3) and Shadow (SHDW) only.	HERECPCVR	1.0 Ⓞ	0.1	\$72

NOTES:

- ⚠ Customer must furnish conduit, wiring and designer type receptacles. (Approved for use by city of Chicago.)
- ⚠ Junction boxes cannot be used back-to-back.

Duplex Color Recommended to Coordinate with Paint Color			
Paint Color	Paint Code	Duplex Color	Duplex Code
Black	P	Black	P
Brownstone	P7D	Brownstone	EY
Charcoal	S	Charcoal	S
Designer White	PJW	Designer White	DW
Fossil	P28	Charcoal	S
Greige	T5	Muslin	T3
Light Gray	Q	Loft	LOFT
Loft	LOFT	Loft	LOFT
Muslin	T3	Muslin	T3
Putty	L	Black	P
Shadow	SHDW	Muslin	T3
Silver	PR6	Titanium	TI
Titanium	P8T	Titanium	TI
Champagne Metallic	T4	Muslin	T3
Platinum Metallic	T1	Titanium	Ti

HOW TO SPECIFY

<p>Select Model Number</p> <p>HH871400 .</p>	<p>Select Paint Color</p> <p>See page 464</p> <p>P</p>
--	--

EMPOWER® Electrical Accessories

GSA SIN 33721 EXCEPT AS NOTED

ABI

Icon Legend on page 19

WORKSTATIONS

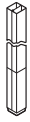

DESCRIPTION

Power Pole
10'5"

MODEL

HMPPP125

SHIP WEIGHT

14

CUBE

0.7

LIST PRICE

P1

\$460

NOTES: Power Pole ships with bracket to attach under stationary Empower® worksurfaces and feed directly into the Wire Management Trough. Power Pole will run to the floor on height adjustable Empower®.



DESCRIPTION

Vertebrae

MODEL

HMPVWM28

SHIP WEIGHT

3.0

CUBE

0.3

LIST PRICE

\$221

NOTES: 30"H x 3 1/4"W x 1 1/2"D. Ships unassembled. For additional information see page 852. For use with stationary Empower®.

❗ Clear finish. Specify "X" for finish option.

SPECIFYING EXAMPLE: HMPVWM28.X

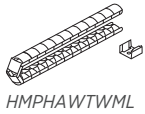

HMPHAWTWM



HMPHATFWML

Wire Managers for Height Adjustable

Workstation to Trough
Trough to Floor

MODEL

HMPHAWTWM

3.0

0.1

\$264

HMPHATFWML

2.0

0.3

\$249

❗ Wire Manager Workstation to Trough only available in black.

OPEN MARKET

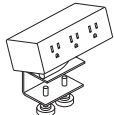

Model HPWRMOD3WC shown

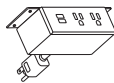

Model HPWRMOD2UWM shown

Power Modules

- 3 Receptacles with Worksurface Clamp
- 3 Receptacles with Under-Worksurface Mounting Bracket
- 2 Receptacles 2 USB with Worksurface Clamp
- 2 Receptacles 2 USB with Under-Worksurface Mounting Bracket
- 6' power cord with standard three-prong plug.
- Under-worksurface mounting bracket models work with any top that has a 5" x 5" square clearance.
- Worksurface clamp models work on any top with a 4" overhang.
- UL Listed.

MODEL

HPWRMOD3WC

2.3

0.2

\$307

HPWRMOD3UWM

2.3

0.2

\$307

HPWRMOD2WC

2.3

0.2

\$491

HPWRMOD2UWM

2.3

0.2

\$491

NOTES: For additional information see page 849.

❗ Color finish coordinates with HON's Charcoal or White. Specify STRM for Storm or SNW for Snow when ordering.
Example: HPWRMOD3WC.STRM.

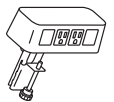

Power & Data Center

- 2 Receptacles 2 Data Accessory
- Standard with two receptacles and openings for two data ports.
- 6' power cord with standard three-prong plug.
- Fits on any worksurface with a 4" overhang.
- UL Listed.

MODEL

HCOMDOME2

2.5

0.2

\$293

NOTES: For additional information see page 849.

❗ Color finish coordinates with HON's Loft. Specify LOFT when ordering. Example: HCOMDOME2.LOFT



Under Worksurface Power Module — 4 Outlets, 10' Cord

- Includes 10' cord with three-prong plug.
- Fits in cable management troughs. See page 564.
- 4 outlets on side create easy access.

MODEL

HPWRMOD2

1.5

0.2

\$401

NOTES: Power Modules will also work with standing-height applications for 10500 Series™ and Voi® desks. Mounting Clearance: 5.025" x 4.875" x 1.375". For additional information see page 849.

❗ Black finish only, no specification needed.

HOW TO SPECIFY

Select
Model Number

Select
Finish Color

STRM Storm
SNW Snow
LOFT Loft

Specify Loft finish for HCOMDOME2 only

H M P P P 1 2 5 .

S T R M

EMPOWER® Voi® Laminate Low Credenzas

GSA SIN 33721



Icon Legend on page 19

WORKSTATIONS

	DESCRIPTION	MODEL	SHIP WEIGHT	CUBE	L1 LIST	L2 UPCHARGES				
						CHASSIS	FRONTS			
	Low Credenza, 2 File/2 Box 72"W x 20"D x 21½"H 60"W x 20"D x 21½"H NOTES: Unit is locking.	HLSL2072LD4	230	21.9	\$1605	\$40	\$40			
		HLSL2060LD4	190	18.9	\$1462	\$35	\$40			
	Low Credenza, 2 File Drawers, Open Top 72"W x 20"D x 21½"H 60"W x 20"D x 21½"H NOTES: Unit is non-locking.	HLSL2072LD2	200	21.9	\$1501	\$40	\$30			
		HLSL2060LD2	160	18.9	\$1370	\$35	\$30			
	Low Credenza, Left Hand Drawers 72"W x 20"D x 21½"H 60"W x 20"D x 21½"H NOTES: Unit is locking.	HLSL2072LL2	200	21.9	\$1486	\$40	\$20			
		HLSL2060LL2	160	18.9	\$1254	\$35	\$20			
	Low Credenza, Right Hand Drawers 72"W x 20"D x 21½"H 60"W x 20"D x 21½"H NOTES: Unit is locking.	HLSL2072LR2	200	21.9	\$1486	\$40	\$20			
		HLSL2060LR2	160	18.9	\$1254	\$35	\$20			
	Low Credenza, Open 72"W x 20"D x 21½"H 60"W x 20"D x 21½"H SPECIFYING EXAMPLE: HLSL2072LDO.Z (model.chassis only)	HLSL2072LDO	170	21.9	\$1262	\$40	N/A			
		HLSL2060LDO	130	18.9	\$1048	\$35	N/A			
	Low Credenza, 4 Storage Doors 72"W x 20"D x 21½"H 60"W x 20"D x 21½"H NOTES: Unit is locking.	HLSL2072S4	190	21.9	\$1593	\$40	\$40			
		HLSL2060S4	160	18.9	\$1367	\$35	\$40			
	Credenza Cushion 20"W x 36"D x 1"H for 72" Credenzas 20"W x 30"D x 1"H for 60" Credenzas NOTES: See pages 462-463 for available fabrics. SPECIFYING EXAMPLE: HLSL2036CH2.APN23	HLSL2036CH2	11	2.2	\$402	\$440	\$478	\$517	\$566	\$616
		HLSL2030CH2	9	1.9	\$372	\$408	\$444	\$480	\$526	\$573

NOTES:

- Chassis and drawer fronts woodgrains and solid laminates are specified separately (see SIF options below).
- File drawers accept hanging folders in letter size.
- Multiple handle locations possible per customer preference.
- Seat cushions are available for low credenzas and mobile pedestals (specify separately).

- Storage accessory model HLSLDRWORG works with box doors.
- Adjustable hex leveling glides allow floor-standing furniture to be easily leveled without lifting the unit; glides have 1¼" adjustable range.
- Ships with one handle per drawer on all units.

ⓘ Locking units equipped with HON "One Key" interchangeable core removable locks. Keyed alike core must be ordered separately.

HOW TO SPECIFY

<p>Select Model Number</p> <p>H L S L 2 0 7 2 L D 4 .</p>	<p>Select Chassis Laminate</p> <p>See page 171</p> <p>N .</p>	<p>Select Drawer Front Laminate</p> <p>See page 171</p> <p>N .</p>	<p>Select Pull Color</p> <p>See page 171</p> <p>Not specified for Open Credenza models HLSL2072LDO, HLSL2060LDO</p> <p>T 4</p>
--	--	---	---



Icon Legend on page 19

EMPOWER[®] Voi[®] Laminate Low Credenzas

WORKSTATIONS

	DESCRIPTION	MODEL	SHIP WEIGHT	CUBE	L1 LIST	L2 UPCHARGES	
						CHASSIS	FRONTS
	Low Credenza — Open						
	30"W x 20"D x 21½"H 36"W x 20"D x 21½"H	HLSL2030LDO HLSL2036LDO	65 85	9.8 12.0	\$868 \$894	\$25 \$30	N/A N/A
	Low Credenza — Open Top, File Drawer						
	30"W x 20"D x 21½"H 36"W x 20"D x 21½"H	HLSL2030LD1 HLSL2036LD1	75 95	9.8 12.0	\$964 \$992	\$25 \$30	\$15 \$15
	Low Credenza — 1 File Drawer, 1 Box Drawer						
	30"W x 20"D x 21½"H 36"W x 20"D x 21½"H	HLSL2030LD2 HLSL2036LD2	80 100	9.8 12.0	\$1071 \$1103	\$25 \$30	\$20 \$20
	Credenza Cushion						
	20"W x 36"D x 1"H for 72" Credenzas 20"W x 30"D x 1"H for 60" Credenzas	HLSL2036CH2 HLSL2030CH2	11 9	2.2 1.9	\$402 \$440 \$478 \$517 \$566 \$616 \$372 \$408 \$444 \$480 \$526 \$573		

NOTES: See pages 462-463 for available fabrics.

ⓘ For model HLSL2030CH2 must order two cushions to cover entire 60" Credenza surface.

SPECIFYING EXAMPLE: HLSL2036CH2.APN23

NOTES:

- File drawers accept hanging folders in letter size.
 - Multiple handle locations possible per customer preference.
 - Seat cushions are available for low credenzas and mobile pedestals (specify separately).
 - Storage accessory model HSLDRWORG works with box doors.
 - Utilize in small footprint applications.
 - Adjustable hex leveling glides allow floor-standing furniture to be easily leveled without lifting the unit; glides have 1/4" adjustable range.
 - Ships with one handle per drawer on all units.
- ⓘ Locking units equipped with HON "One Key" interchangeable core removable locks. Keyed alike core must be ordered separately.

HOW TO SPECIFY

<p>Select Model Number</p> <p>See page 171</p> <p>H L S L 2 0 3 0 L D O .</p>	<p>Select Chassis Laminate</p> <p>See page 171</p> <p>N .</p>	<p>Select Drawer Front Laminate</p> <p>See page 171</p> <p>Not specified for Open Credenza models HLSL2030LDO, HLSL2036LDO</p> <p>N .</p>	<p>Select Pull Color</p> <p>See page 171</p> <p>Not specified for Open Credenza models HLSL2030LDO, HLSL2036LDO</p> <p>T 4</p>
--	--	--	---

EMPOWER® Voi® Laminate Mobile Storage

GSA SIN 33721



Icon Legend on page 19

WORKSTATIONS

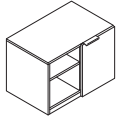

DESCRIPTION

Mobile Credenza
30"W x 20"D x 21½"H
NOTES: Unit is non-locking.

MODEL	SHIP WEIGHT	CUBE	L1 LIST	L2 UPCHARGES	
				CHASSIS	FRONTS
HLSL2030MCO	80	9.8	\$1399	\$25	\$10

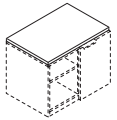

DESCRIPTION

Credenza Cushion
20"W x 30"D x 1"H for 60" Credenzas
NOTES: See pages 462-463 for available fabrics.
SPECIFYING EXAMPLE: HLSL2030CH2.APN23

MODEL	SHIP WEIGHT	CUBE	1	2	3	4	5	6
HLSL2030CH2	9	1.9	\$372	\$408	\$444	\$480	\$526	\$573

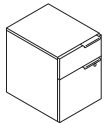

DESCRIPTION

Mobile Pedestal
15¾"W x 20⅞"D x 21⅞"H
NOTES: Unit is locking.

MODEL	SHIP WEIGHT	CUBE	L1 LIST	L2 UPCHARGES	
				CHASSIS	FRONTS
HLSL2016MP2	65	5.7	\$794	\$20	\$10

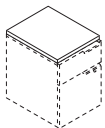

DESCRIPTION

Mobile Pedestal Cushion
15⅞"W x 20"D x 1"H for Pedestals
NOTES: See pages 462-463 for available fabrics.
SPECIFYING EXAMPLE: HLSL2016PH2.APN23

MODEL	SHIP WEIGHT	CUBE	1	2	3	4	5	6
HLSL2016PH2	6	1.1	\$309	\$333	\$357	\$381	\$412	\$443

NOTES:

- Chassis and drawer fronts woodgrains and solid laminates are specified separately (see SIF options below).
- File drawers accept hanging folders in letter or legal size.
- Multiple handle locations possible per customer preference.
- Seat cushions are available for low credenzas, floor credenzas, and mobile pedestals (specify separately). See pages 508-510 for Pedestal and Credenza cushion models.
- Storage accessory model HSLDRWORG works with box doors.
- Standard box drawers operate on ball-bearing suspension with 70% extension. File drawers operate on ball-bearing suspension with 70% extension.
- Ships with one handle per drawer on all units.

! Locking units equipped with HON "One Key" interchangeable core removable locks. Keyed alike core must be ordered separately.

HOW TO SPECIFY

<p>Select Model Number</p> <p>HLSL2030MCO</p>	<p>Select Chassis Laminate</p> <p>See page 464</p> <p>N</p>	<p>Select Drawer Front Laminate</p> <p>See page 464</p> <p>N</p>	<p>Select Pull Color</p> <p>P Black T4 Champagne T1 Platinum PJW Designer White PR6 Silver PBX Solar Black</p> <p>T4</p>
--	--	---	---

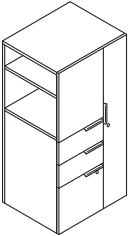
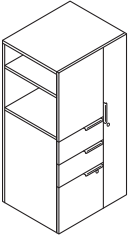
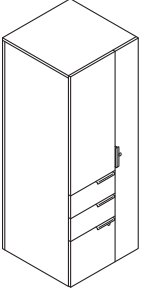
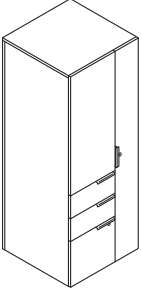

EMPOWER® Voi® Laminate Storage Towers

	DESCRIPTION	MODEL	SHIP WEIGHT	CUBE	L1 LIST	L2 UPCHARGES	
						CHASSIS	FRONTS
	24"W x 20"D Storage Tower — Right Hand Drawers, Left Hand Door						
	24"W x 20"D x 50"H, Left	HLSLW045L	167	17.4	\$1919	\$50	\$35
	24"W x 20"D x 65"H, Left	HLSLW046L	200	22.5	\$2188	\$55	\$35
	24"W x 20"D Storage Tower — Left Hand Drawers, Right Hand Door						
	24"W x 20"D x 50"H, Right	HLSLW045R	167	17.4	\$1919	\$50	\$35
	24"W x 20"D x 65"H, Right	HLSLW046R	200	22.5	\$2188	\$55	\$35
	24"W x 24"D Storage Tower — Right Hand Drawers, Left Hand Door						
	24"W x 24"D x 50"H, Left	HLSLW445L	200	20.7	\$2078	\$55	\$35
	24"W x 24"D x 65"H, Left	HLSLW446L	240	27.8	\$2304	\$60	\$35
	24"W x 24"D Storage Tower — Left Hand Drawers, Right Hand Door						
	24"W x 24"D x 50"H, Right	HLSLW445R	200	20.7	\$2078	\$55	\$35
	24"W x 24"D x 65"H, Right	HLSLW446R	240	27.8	\$2304	\$60	\$35
	24"W x 24"D Personal Storage Tower						
	24"W x 24"D x 65"H, Left	HLSLW446LP	250	27.8	\$2609	\$60	\$35
	24"W x 24"D x 65"H, Right	HLSLW446RP	250	27.8	\$2609	\$60	\$35

NOTES:

- Chassis and drawer fronts woodgrains and solid laminates are specified separately (see SIF options below).
 - File drawers accept hanging folders in letter or legal size.
 - Wardrobe, middle box drawer and file drawer are locking.
 - Standard box drawers operate on ball-bearing suspension with full extension. File, lateral, and wide box drawers operate on ball-bearing suspension with full extension.
 - Ships with one handle per drawer on all units.
 - Adjustable hex leveling glides allow floor-standing furniture to be easily leveled without lifting the unit; glides have 1/4" adjustable range.
 - Wardrobe/storage cabinet includes coat rod.
 - Wardrobes contain easy access side storage shelves.
- ! Locking units equipped with HON "One Key" interchangeable core removable locks. Keyed alike core must be ordered separately.

HOW TO SPECIFY

<p>Select Model Number</p> <p>HL SLW045L</p>	<p>Select Chassis Laminate</p> <p>See page 171</p> <p>N</p>	<p>Select Drawer Front Laminate</p> <p>See page 171</p> <p>N</p>	<p>Select Pull Color</p> <p>See page 171</p> <p>T4</p>
---	--	---	---

EMPOWER® Voi® Laminate Storage Towers

GSA SIN 33721



Icon Legend on page 19

WORKSTATIONS

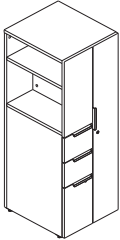

DESCRIPTION	MODEL	SHIP WEIGHT	CUBE	L1 LIST	L2 UPCHARGES	
					CHASSIS	FRONTS
18''W x 20''D Storage Towers — Right Hand Drawers, Left Hand Door						
18''W x 20''D x 50''H, Left	HLSLW085L	139	13.4	\$1728	\$45	\$35
18''W x 20''D x 65''H, Left	HLSLW086L	167	17.3	\$1973	\$50	\$35
18''W x 20''D Storage Towers — Left Hand Drawers, Right Hand Door						
18''W x 20''D x 50''H, Right	HLSLW085R	139	13.4	\$1728	\$45	\$35
18''W x 20''D x 65''H, Right	HLSLW086R	167	17.3	\$1973	\$50	\$35

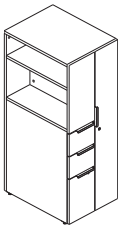

18''W x 24''D Storage Towers — Right Hand Drawers, Left Hand Door						
18''W x 24''D x 50''H, Left	HLSLW485L	167	15.8	\$1966	\$50	\$35
18''W x 24''D x 65''H, Left	HLSLW486L	200	21.5	\$2191	\$55	\$35
18''W x 24''D Storage Towers — Left Hand Drawers, Right Hand Door						
18''W x 24''D x 50''H, Right	HLSLW485R	167	15.8	\$1966	\$50	\$35
18''W x 24''D x 65''H, Right	HLSLW486R	200	21.5	\$2191	\$55	\$35

NOTES:

- Ships with one handle per drawer on all units.
- Chassis and drawer fronts woodgrains and solid laminates are specified separately (see SIF options below).
- File drawers accept hanging folders in letter or legal size.
- Standard box drawers operate on ball-bearing suspension with full extension. File and box drawers operate on ball-bearing suspension with full extension.
- Adjustable hex leveling glides allow floor-standing furniture to be easily leveled without lifting the unit; glides have 1/4" adjustable range.
- Wardrobe/storage cabinet includes coat rod.
- Wardrobes contain easy access side storage shelves.
- Wardrobe, middle box drawer and file drawer are locking.

! Locking units equipped with HON "One Key" interchangeable core removable locks. Keyed alike core must be ordered separately.

HOW TO SPECIFY

<p>Select Model Number</p> <p>HL S L W 0 8 5 L</p>	<p>Select Chassis Laminate</p> <p>See page 171</p> <p>N</p>	<p>Select Door/Drawer Front Laminate</p> <p>See page 171</p> <p>N</p>	<p>Select Pull Color</p> <p>See page 171</p> <p>T 4</p>
---	--	--	--



Icon Legend on page 19

EMPOWER® Contain® Metal Credenzas

	DESCRIPTION	MODEL	SHIP WEIGHT	CUBE	LIST PRICE BY PAINT GRADE		
					P1	P2	P3
	Low Credenza, Box/Lateral Left, Open Shelf Right						
	72"W x 18"D x 22"H	HSCBX227218RBFOM(?) ⓧ	150	20.7	\$1921	\$1988	\$2056
	60"W x 18"D x 22"H	HSCBX226018RBFOM(?) ⓧ	130	17.3	\$1733	\$1800	\$1868
	48"W x 18"D x 22"H	HSCBX224818RBFOM(?) ⓧ	111	14.0	\$1598	\$1665	\$1733
	Low Credenza, Box/Lateral Right, Open Shelf Left						
	72"W x 18"D x 22"H	HSCBX227218LBFOM(?) ⓧ	150	20.7	\$1921	\$1988	\$2056
	60"W x 18"D x 22"H	HSCBX226018LBFOM(?) ⓧ	130	17.3	\$1733	\$1800	\$1868
	48"W x 18"D x 22"H	HSCBX224818LBFOM(?) ⓧ	111	14.0	\$1598	\$1665	\$1733
	Low Credenza, Box/Lateral						
	36"W x 18"D x 22"H	HSCBX223618BFM(?) ⓧ	87	10.6	\$1175	\$1208	\$1243
	30"W x 18"D x 22"H	HSCBX223018BFM(?) ⓧ	76	9.0	\$1125	\$1158	\$1193
	Open Shelf						
	36"W x 18"D x 22"H	HSCBX2236180 ⓧ	66	10.6	\$836	\$869	\$904
	30"W x 18"D x 22"H	HSCBX2230180 ⓧ	60	9.0	\$771	\$804	\$839

NOTES:

- Metal chassis and drawer fronts.
 - Lateral and wide box drawers operate on ball-bearing suspension with full extension.
 - Steel ball-bearing drawer suspensions.
 - Ships complete with standard kickplate.
 - Field installable counterweight sold separately.
 - File drawers accept hanging folders in letter or legal size.
 - Steel frame provides durability.
 - Use with laminate tops and credenza seat cushions. Order separately — see pages 634 and 517.
- ⓘ Locking units equipped with HON "One Key" interchangeable core removable locks. Keyed alike core model HF23S, in Satin, must be ordered separately. See page 634.
- ⓧ Discontinued 4/6/20.

HOW TO SPECIFY

<p>Select Model Number</p> <p>Replace (?) with handle choice</p> <p>A Satin Chrome Arch N Full Face Integral R Full Radius Pull</p> <p>Pull not specified for Open Shelf models</p>	<p>Select Paint Color</p> <p>See page 464 Contain® Storage finish options</p>	<p>Select Lock Option</p> <p>L Standard Lock X Omit Lock (deduct \$20)</p> <p>Not specified for models HSCBX2236180 and HSCBX2230180</p>
<p>H S C B X 2 2 7 2 1 8 R B F O M A .</p>	<p>P .</p>	<p>L</p>

EMPOWER® Contain® Footed Metal Credenzas

GSA SIN 33721



Icon Legend on page 19

WORKSTATIONS

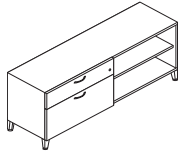

DESCRIPTION

Footed Low Credenza, Box/Lateral Left, Open Shelf Right
 72"W x 18"D x 22"H
 60"W x 18"D x 22"H
 48"W x 18"D x 22"H

MODEL

HSCSF227218RBFOM(?) Ⓢ
HSCSF226018RBFOM(?) Ⓢ
HSCSF224818RBFOM(?) Ⓢ

SHIP WEIGHT

CUBE

150
130
111

17.7
14.9
12.0

LIST PRICE BY PAINT GRADE

P1 P2 P3

\$2076 \$2143 \$2211
\$1889 \$1956 \$2024
\$1723 \$1790 \$1858

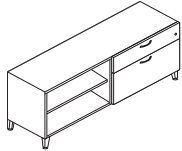

Footed Low Credenza, Box/Lateral Right, Open Shelf Left
 72"W x 18"D x 22"H
 60"W x 18"D x 22"H
 48"W x 18"D x 22"H

HSCSF227218LBFOM(?) Ⓢ
HSCSF226018LBFOM(?) Ⓢ
HSCSF224818LBFOM(?) Ⓢ

150
130
111

17.7
14.9
12.0

\$2076 \$2143 \$2211
\$1889 \$1956 \$2024
\$1723 \$1790 \$1858



Footed Low Credenza, Box/Lateral
 36"W x 18"D x 22"H
 30"W x 18"D x 22"H

HSCSF223618BFM(?) Ⓢ
HSCSF223018BFM(?) Ⓢ

87
76

9.1
7.7

\$1299 \$1332 \$1367
\$1249 \$1282 \$1317



Footed Open Shelf
 36"W x 18"D x 22"H
 30"W x 18"D x 22"H

HSCSF223618O Ⓢ
HSCSF223018O Ⓢ

66
60

9.1
7.7

\$961 \$994 \$1029
\$895 \$928 \$963

NOTES:

- Lateral and wide box drawers operate on ball-bearing suspension with full extension.
- Steel ball-bearing drawer suspensions.
- Ships complete with standard footed base.
- Field installable counterweight sold separately.
- File drawers accept hanging folders in letter or legal size.
- Steel frame provides durability.
- Feet are shipped with the credenza unit and are easily assembled.
- Use with laminate tops and credenza seat cushions. Order separately — see pages 634 and 517.

⚠ Locking units equipped with HON "One Key" interchangeable core removable locks. Keyed alike core model HF23S, in Satin, must be ordered separately. See page 634.

Ⓢ Discontinued 4/6/20.

HOW TO SPECIFY

<p>Select Model Number</p> <p>Replace (?) with handle choice</p> <p>A Satin Chrome Arch N Full Face Integral R Full Radius Pull</p> <p>Pull not specified for Open Shelf models</p> <p>H S C S F 2 2 7 2 1 8 R B F O M A .</p>	<p>Select Paint Color</p> <p>See page 464 Contain® Storage finish options</p> <p>P .</p>	<p>Select Lock Option</p> <p>L Standard Lock X Omit Lock (deduct \$20)</p> <p>Not specified for models HSCSF223618O and HSCSF223018O</p> <p>L .</p>	<p>Select Foot Color</p> <p>T1 Platinum Metallic PR6 Silver</p> <p>T 1</p>
--	---	---	--



Icon Legend on page 19

Contain® Metal Credenzas with Laminate Fronts

	DESCRIPTION	MODEL	SHIP WEIGHT	CUBE	LIST PRICE BY PAINT GRADE		
					P1	P2	P3
	Metal Low Credenza, Laminated Front, Box/Lateral Left, Open Shelf Right						
	72"W x 18"D x 22"H	HSCBX227218RBFOL(?) Ⓢ	152	20.7	\$2131	\$2198	\$2266
	60"W x 18"D x 22"H	HSCBX226018RBFOL(?) Ⓢ	132	17.3	\$1943	\$2010	\$2078
	48"W x 18"D x 22"H	HSCBX224818RBFOL(?) Ⓢ	113	14.0	\$1808	\$1875	\$1943
	! Replace (?) with handle choice. Available in Satin Chrome Arch only.						
	Metal Low Credenza, Laminated Front, Box/Lateral Right, Open Shelf Left						
	72"W x 18"D x 22"H	HSCBX227218LBFOL(?) Ⓢ	152	20.7	\$2131	\$2198	\$2266
	60"W x 18"D x 22"H	HSCBX226018LBFOL(?) Ⓢ	132	17.3	\$1943	\$2010	\$2078
	48"W x 18"D x 22"H	HSCBX224818LBFOL(?) Ⓢ	113	14.0	\$1808	\$1875	\$1943
	! Replace (?) with handle choice. Available in Satin Chrome Arch only.						
	Metal Low Credenza, Laminated Front Box/Lateral						
	36"W x 18"D x 22"H	HSCBX223618BFL(?) Ⓢ	89	10.6	\$1385	\$1418	\$1453
	30"W x 18"D x 22"H	HSCBX223018BFL(?) Ⓢ	76	9.0	\$1335	\$1368	\$1403
	! Replace (?) with handle choice. Available in Satin Chrome Arch only.						

NOTES:

- Lateral and wide box drawers operate on ball-bearing suspension with full extension.
- Steel ball-bearing drawer suspensions.
- Ships complete with standard kickplate.
- Field installable counterweight sold separately.
- File drawers accept hanging folders in letter or legal size.
- Steel frame provides durability.
- Use with laminate tops and credenza seat cushions. Order separately — see pages 634 and 517.

! Available in Satin Chrome Arch only.

! Locking units equipped with HON "One Key" interchangeable core removable locks. Keyed alike core model HF23S, in Satin, must be ordered separately. See page 634.

Ⓢ Discontinued 4/6/20.

HOW TO SPECIFY

<p>Select Model Number</p> <p>Replace (?) with handle choice</p> <p>A Satin Chrome Arch</p>	<p>Select Paint Color</p> <p>See page 464 Contain® Storage finish options</p>	<p>Select Lock Option</p> <p>L Standard Lock X Omit Lock (deduct \$20)</p>	<p>Select Laminate Option</p> <p>L1 (no upcharge)</p> <p>COGN Cognac C Harvest N Mahogany MOCH Mocha D Natural Maple PINC Pinnacle F Shaker Cherry</p> <p>L2 (\$35 upcharge)</p> <p>LLA1 Lowell Ash LNRI Natural Recon LPE1 Phantom Ecru LPT1 Portico Teak LSW1 Skyline Walnut</p>
<p>H S C B X 2 2 7 2 1 8 R B F O L A .</p>	<p>P .</p>	<p>L .</p>	<p>C</p>



Icon Legend on page 19

Contain® Footed Metal Credenzas with Laminate Fronts

WORKSTATIONS

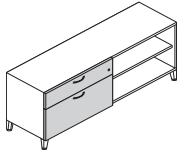

DESCRIPTION	MODEL	SHIP WEIGHT	CUBE	LIST PRICE BY PAINT GRADE		
				P1	P2	P3
Footed Low Credenza, Laminate Front, Box/Lateral Left, Open Shelf Right						
72"W x 18"D x 22"H	HSCSF227218RBFOL(?) ⓧ	152	17.7	\$2287	\$2354	\$2422
60"W x 18"D x 22"H	HSCSF226018RBFOL(?) ⓧ	132	14.9	\$2097	\$2164	\$2232
48"W x 18"D x 22"H	HSCSF224818RBFOL(?) ⓧ	113	12.0	\$1932	\$1999	\$2067

⚠ Replace (?) with handle choice. Available in Satin Chrome Arch only.

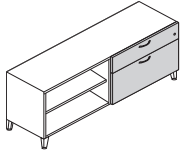

Footed Low Credenza, Laminate Front, Box/Lateral Right, Open Shelf Left						
72"W x 18"D x 22"H	HSCSF227218LBFOL(?) ⓧ	152	17.7	\$2287	\$2354	\$2422
60"W x 18"D x 22"H	HSCSF226018LBFOL(?) ⓧ	132	14.9	\$2097	\$2164	\$2232
48"W x 18"D x 22"H	HSCSF224818LBFOL(?) ⓧ	113	12.0	\$1932	\$1999	\$2067

⚠ Replace (?) with handle choice. Available in Satin Chrome Arch only.

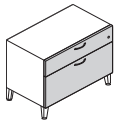

Footed Low Credenza, Laminate Front Box/Lateral						
36"W x 18"D x 22"H	HSCSF223618BFL(?) ⓧ	89	9.1	\$1509	\$1542	\$1577
30"W x 18"D x 22"H	HSCSF223018BFL(?) ⓧ	78	7.7	\$1460	\$1493	\$1528

⚠ Replace (?) with handle choice. Available in Satin Chrome Arch only.

NOTES:

- Lateral and wide box drawers operate on ball-bearing suspension with full extension.
- Steel ball-bearing drawer suspensions.
- Ships complete with standard footed base.
- Field installable counterweight sold separately.
- File drawers accept hanging folders in letter or legal size.
- Steel frame provides durability.
- Feet are shipped with the credenza unit and are easily assembled.
- Use with laminate tops and credenza seat cushions. Order separately — see pages 634 and 517.

⚠ Available in Satin Chrome Arch only.

⚠ Locking units equipped with HON "One Key" interchangeable core removable locks. Keyed alike core model HF23S, in Satin, must be ordered separately. See page 634.

ⓧ Discontinued 4/6/20.

HOW TO SPECIFY

Select Model Number	Select Paint Color	Select Lock Option	Select Laminate Option	Select Foot Color
Replace (?) with handle choice A Satin Chrome Arch	See page 464 Contain® Storage finish options	L Standard Lock X Omit Lock (deduct \$20)	L1 (no upcharge) COGN Cognac C Harvest N Mahogany MOCH Mocha D Natural Maple PINC Pinnacle F Shaker Cherry L2 (\$35 upcharge) LLA1 Lowell Ash LNRI Natural Recon LPE1 Phantom Ecru LPT1 Portico Teak LSW1 Skyline Walnut	T1 Platinum Metallic PR6 Silver
H S C S F 2 2 7 2 1 8 R B F O L A .	P .	L .	C .	T 1



Icon Legend on page 19

EMPOWER[®] Contain[®] Metal Credenzas Accessories

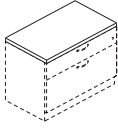

DESCRIPTION	MODEL	SHIP WEIGHT	CUBE												
				1	2	3	4	5	6	7	8	9	10	11	12
Credenza Cushion 36"W x 18"D for 60" and 72" Credenzas	HSCAUC1836 Ⓢ	16.3	1.6	\$278	\$316	\$354	\$393	\$442	\$492	\$542	\$591	\$641	\$690	\$740	\$790
30"W x 18"D for 48" and 60" Credenzas	HSCAUC1830 Ⓢ	16.3	1.6	\$259	\$297	\$335	\$374	\$423	\$473	\$523	\$572	\$622	\$671	\$721	\$771
24"W x 18"D for 48" Credenzas	HSCAUC1824 Ⓢ	16.3	1.9	\$242	\$280	\$318	\$357	\$406	\$456	\$506	\$555	\$605	\$654	\$704	\$754

NOTES: For matching Pedestal Seats, see page 530. Credenza Cushions are available in 24", 30" and 36" size options. Choose from multiple upholstery options, see pages 462-463. See pages 22-24 for available fabrics.

SPECIFYING EXAMPLE: HSCAUC1836.APN23

NOTES:

Ⓢ Discontinued 4/6/20.

HOW TO SPECIFY

<p>Select Model Number</p> <p>H S C A U C 1 8 3 6 .</p>	<p>Select Fabric</p> <p>See pages 462-463</p> <p>A B 1 0</p>
--	---

EMPOWER® Contain® Metal Personal Towers

GSA SIN 33721



Icon Legend on page 19

WORKSTATIONS

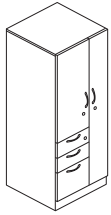

DESCRIPTION	MODEL	SHIP WEIGHT	CUBE	LIST PRICE BY PAINT GRADE		
				P1	P2	P3
Personal Tower with Metal Fronts, Door/Box/Box/File						
65"H x 24"W x 24"D, Wardrobe Left	HSTBX652424LBBFM(?) Ⓢ	255	25.6	\$2617	\$2694	\$2762
65"H x 24"W x 24"D, Wardrobe Right	HSTBX652424RBBFM(?) Ⓢ	255	25.6	\$2617	\$2694	\$2762

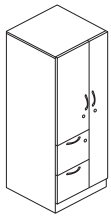

Personal Tower with Metal Fronts, Door/File/File						
65"H x 24"W x 24"D, Wardrobe Left	HSTBX652424LFFM(?) Ⓢ	255	25.6	\$2617	\$2694	\$2762
65"H x 24"W x 24"D, Wardrobe Right	HSTBX652424RFFM(?) Ⓢ	255	25.6	\$2617	\$2694	\$2762



Personal Tower with Metal Fronts, Door/Box/Box/File						
50"H x 24"W x 24"D, Wardrobe Left	HSTBX502424LBBFM(?) Ⓢ	215	19.8	\$2146	\$2223	\$2281
50"H x 24"W x 24"D, Wardrobe Right	HSTBX502424RBBFM(?) Ⓢ	215	19.8	\$2146	\$2223	\$2281

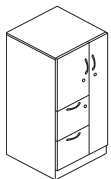

Personal Tower with Metal Fronts, Door/File/File						
50"H x 24"W x 24"D, Wardrobe Left	HSTBX502424LFFM(?) Ⓢ	215	19.8	\$2146	\$2223	\$2281
50"H x 24"W x 24"D, Wardrobe Right	HSTBX502424RFFM(?) Ⓢ	215	19.8	\$2146	\$2223	\$2281

NOTES:

- Metal chassis and drawer fronts.
- Steel frame provides durability.
- Leveling glides can be adjusted from outside or inside the case.
- Heavy-duty, telescoping ball-bearing slides.
- Durable baked enamel finish is applied over rust-inhibiting phosphate pre-treatment.
- Three locks secure doors and drawers.
- Pencil tray standard in top box drawer.

- One box divider standard in each box drawer.
- One crossrail standard in each file drawer.

ⓘ Locking units equipped with HON "One Key" interchangeable core removable locks. Keyed alike core model HF23S, in Satin, must be ordered separately. See page 634.

Ⓢ Discontinued 4/6/20.

HOW TO SPECIFY

<p>Select Model Number</p> <p>Replace (?) with handle choice</p> <p>A Satin Chrome Arch N Full Face Integral R Full Radius</p>	<p>Select Paint Color</p> <p>See page 464 Contain® Storage finish options</p>	<p>Select Lock Option</p> <p>L Standard Lock X Omit Lock (deduct \$60)</p>
<p>H S T B X 6 5 2 4 2 4 L B B F M A .</p>	<p>P .</p>	<p>L</p>



Icon Legend on page 19

Contain® Metal Side Access Towers

	DESCRIPTION	MODEL	SHIP WEIGHT	CUBE	LIST PRICE BY PAINT GRADE		
					P1	P2	P3
	Side Access Tower with Metal Fronts, Shelves/Box/Box/File						
	65”H x 24”W x 24”D, Wardrobe Left	HSTSBX652424LBBFM(?) Ⓣ	255	25.6	\$2454	\$2531	\$2599
	65”H x 24”W x 24”D, Wardrobe Right	HSTSBX652424RBBFM(?) Ⓣ	255	25.6	\$2454	\$2531	\$2599
	Side Access Tower with Metal Fronts, Shelves/File/File						
	65”H x 24”W x 24”D, Wardrobe Left	HSTSBX652424LFFM(?) Ⓣ	255	25.6	\$2454	\$2531	\$2599
	65”H x 24”W x 24”D, Wardrobe Right	HSTSBX652424RFFM(?) Ⓣ	255	25.6	\$2454	\$2531	\$2599
	Side Access Tower with Metal Fronts, Shelves/Box/Box/File						
	50”H x 24”W x 24”D, Wardrobe Left	HSTSBX502424LBBFM(?) Ⓣ	215	19.8	\$2082	\$2159	\$2217
	50”H x 24”W x 24”D, Wardrobe Right	HSTSBX502424RBBFM(?) Ⓣ	215	19.8	\$2082	\$2159	\$2217
	Side Access Tower with Metal Fronts, Shelves/File/File						
	50”H x 24”W x 24”D, Wardrobe Left	HSTSBX502424LFFM(?) Ⓣ	215	19.8	\$2082	\$2159	\$2217
	50”H x 24”W x 24”D, Wardrobe Right	HSTSBX502424RFFM(?) Ⓣ	215	19.8	\$2082	\$2159	\$2217

NOTES:

- A Worksurface to Tower Bracket Kit ships standard with each model.
- Metal chassis and drawer fronts.
- Steel frame provides durability.
- Leveling glides can be adjusted from outside or inside the case.
- Heavy-duty, telescoping ball-bearing slides.
- Durable baked enamel finish is applied over rust-inhibiting phosphate pre-treatment.
- Two locks secure doors and drawers.
- Pencil tray standard in top box drawer.
- One box divider standard in each box drawer.
- One crossrail standard in each file drawer.

ⓘ Locking units equipped with HON “One Key” interchangeable core removable locks. Keyed alike core model HF23S, in Satin, must be ordered separately. See page 634.

Ⓣ Discontinued 4/6/20.

HOW TO SPECIFY

<p>Select Model Number</p> <p>Replace (?) with handle choice</p> <p>A Satin Chrome Arch N Full Face Integral R Full Radius</p>	<p>Select Paint Color</p> <p>See page 464 Contain® Storage finish options</p>	<p>Select Lock Option</p> <p>L Standard Lock X Omit Lock (deduct \$60)</p>
<p>H S T S B X 6 5 2 4 2 4 L B B F M A .</p>	<p>P .</p>	<p>L</p>

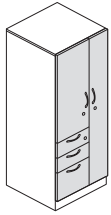

DESCRIPTION	MODEL	SHIP WEIGHT	CUBE	LIST PRICE BY PAINT GRADE		
				P1	P2	P3
Personal Tower with Laminate Fronts, Door/Box/Box/File						
65"H x 24"W x 24"D, Wardrobe Left	HSTBX652424LBBFL(?) Ⓢ	255	25.6	\$2987	\$3064	\$3132
65"H x 24"W x 24"D, Wardrobe Right	HSTBX652424RBBFL(?) Ⓢ	255	25.6	\$2987	\$3064	\$3132

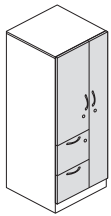

Personal Tower with Laminate Fronts, Door/File/File						
65"H x 24"W x 24"D, Wardrobe Left	HSTBX652424LFFL(?) Ⓢ	255	25.6	\$2987	\$3064	\$3132
65"H x 24"W x 24"D, Wardrobe Right	HSTBX652424RFFL(?) Ⓢ	255	25.6	\$2987	\$3064	\$3132

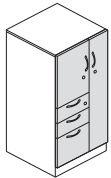

Personal Tower with Laminate Fronts, Door/Box/Box/File						
50"H x 24"W x 24"D, Wardrobe Left	HSTBX502424LBBFL(?) Ⓢ	215	19.8	\$2468	\$2545	\$2603
50"H x 24"W x 24"D, Wardrobe Right	HSTBX502424RBBFL(?) Ⓢ	215	19.8	\$2468	\$2545	\$2603

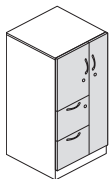

Personal Tower with Laminate Fronts, Door/File/File						
50"H x 24"W x 24"D, Wardrobe Left	HSTBX502424LFFL(?) Ⓢ	215	19.8	\$2468	\$2545	\$2603
50"H x 24"W x 24"D, Wardrobe Right	HSTBX502424RFFL(?) Ⓢ	215	19.8	\$2468	\$2545	\$2603

NOTES:

- Metal chassis with laminate drawer/door fronts.
- Steel frame provides durability.
- Leveling glides can be adjusted from outside or inside the case.
- Heavy-duty, telescoping ball-bearing slides.
- Durable baked enamel finish is applied over rust-inhibiting phosphate pre-treatment.
- Three locks secure doors and drawers.
- Pencil tray standard in top box drawer.
- One box divider standard in each box drawer.
- One crossrail standard in each file drawer.
- ⓘ Available in Satin Chrome Arch only.
- ⓘ Locking units equipped with HON "One Key" interchangeable core removable locks. Keyed alike core model HF23S, in Satin, must be ordered separately. See page 634.
- Ⓢ Discontinued 4/6/20.

HOW TO SPECIFY

<p>Select Model Number</p> <p>Replace (?) with handle choice</p> <p>A Satin Chrome Arch</p>	<p>Select Paint Color</p> <p>See page 464 Contain® Storage finish options</p>	<p>Select Lock Option</p> <p>L Standard Lock X Omit Lock (deduct \$60)</p>	<p>Select Laminate Option</p> <p>L1 (no upcharge)</p> <p>COGN Cognac C Harvest N Mahogany MOCH Mocha D Natural Maple PINC Pinnacle F Shaker Cherry</p> <p>L2 (\$35 upcharge)</p> <p>LLA1 Lowell Ash LNRI Natural Recon LPE1 Phantom Ecru LPT1 Portico Teak LSW1 Skyline Walnut</p>
<p>H S T B X 6 5 2 4 2 4 L B B F L A .</p>	<p>P .</p>	<p>L .</p>	<p>C</p>



Icon Legend on page 19

Contain® Metal Side Access Towers with Laminate Fronts

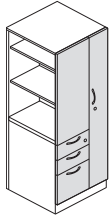

DESCRIPTION	MODEL	SHIP WEIGHT	CUBE	LIST PRICE BY PAINT GRADE		
				P1	P2	P3
Side Access Tower with Laminate Fronts, Shelves/Box/Box/File						
65”H x 24”W x 24”D, Wardrobe Left	HSTSBX652424LBBFL(?) Ⓢ	255	25.6	\$2824	\$2901	\$2969
65”H x 24”W x 24”D, Wardrobe Right	HSTSBX652424RBBFL(?) Ⓢ	255	25.6	\$2824	\$2901	\$2969

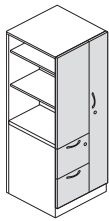

Side Access Tower with Laminate Fronts, Shelves/File/File						
65”H x 24”W x 24”D, Wardrobe Left	HSTSBX652424LFFL(?) Ⓢ	255	25.6	\$2824	\$2901	\$2969
65”H x 24”W x 24”D, Wardrobe Right	HSTSBX652424RFFL(?) Ⓢ	255	25.6	\$2824	\$2901	\$2969

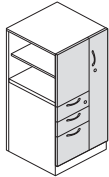

Side Access Tower with Laminate Fronts, Shelves/Box/Box/File						
50”H x 24”W x 24”D, Wardrobe Left	HSTSBX502424LBBFL(?) Ⓢ	215	19.8	\$2404	\$2481	\$2539
50”H x 24”W x 24”D, Wardrobe Right	HSTSBX502424RBBFL(?) Ⓢ	215	19.8	\$2404	\$2481	\$2539

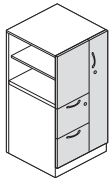

Side Access Tower with Laminate Fronts, Shelves/File/File						
50”H x 24”W x 24”D, Wardrobe Left	HSTSBX502424LFFL(?) Ⓢ	215	19.8	\$2404	\$2481	\$2539
50”H x 24”W x 24”D, Wardrobe Right	HSTSBX502424RFFL(?) Ⓢ	215	19.8	\$2404	\$2481	\$2539

NOTES:

- A Worksurface to Tower Bracket Kit ships standard with each model.
- Metal chassis with laminate drawer/door fronts.
- Steel frame provides durability.
- Leveling glides can be adjusted from outside or inside the case.
- Heavy-duty, telescoping ball-bearing slides.
- Durable baked enamel finish is applied over rust-inhibiting phospho pre-treatment.
- Two locks secure doors and drawers.
- Pencil tray standard in top box drawer.

- One box divider standard in each box drawer.
- One crossrail standard in each file drawer.
- ⓘ Available in Satin Chrome Arch only.
- ⓘ Locking units equipped with HON “One Key” interchangeable core removable locks. Keyed alike core model HF23S, in Satin, must be ordered separately. See page 634.
- Ⓢ Discontinued 4/6/20.

HOW TO SPECIFY

<p>Select Model Number</p> <p>Replace (?) with handle choice</p> <p>A Satin Chrome Arch</p>	<p>Select Paint Color</p> <p>See page 464 Contain® Storage finish options</p>	<p>Select Lock Option</p> <p>L Standard Lock X Omit Lock (deduct \$60)</p>	<p>Select Laminate Option</p> <p>L1 (no upcharge)</p> <p>COGN Cognac C Harvest N Mahogany MOCH Mocha D Natural Maple PINC Pinnacle F Shaker Cherry</p> <p>L2 (\$35 upcharge)</p> <p>LLA1 Lowell Ash LNRI Natural Recon LPE1 Phantom Ecru LPT1 Portico Teak LSW1 Skyline Walnut</p>
<p>H S T S B X 6 5 2 4 2 4 L B B F L A .</p>	<p>P .</p>	<p>L .</p>	<p>C</p>

EMPOWER®

Contain® Footed Metal Personal Towers

GSA SIN 33721



Icon Legend on page 19

WORKSTATIONS

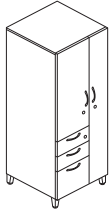

DESCRIPTION	MODEL	SHIP WEIGHT	CUBE	LIST PRICE BY PAINT GRADE		
				P1	P2	P3
Footed Personal Tower with Metal Fronts, Door/Box/Box/File						
65"H x 24"W x 24"D, Wardrobe Left	HSTSF652424LBBFM(?) Ⓢ	255	24.3	\$2736	\$2813	\$2881
65"H x 24"W x 24"D, Wardrobe Right	HSTSF652424RBBFM(?) Ⓢ	255	24.3	\$2736	\$2813	\$2881

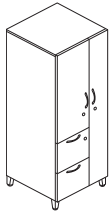

Footed Personal Tower with Metal Fronts, Door/File/File						
65"H x 24"W x 24"D, Wardrobe Left	HSTSF652424LFFM(?) Ⓢ	255	24.3	\$2736	\$2813	\$2881
65"H x 24"W x 24"D, Wardrobe Right	HSTSF652424RFFM(?) Ⓢ	255	24.3	\$2736	\$2813	\$2881



Footed Personal Tower with Metal Fronts, Door/Box/Box/File						
50"H x 24"W x 24"D, Wardrobe Left	HSTSF502424LBBFM(?) Ⓢ	215	18.6	\$2267	\$2344	\$2402
50"H x 24"W x 24"D, Wardrobe Right	HSTSF502424RBBFM(?) Ⓢ	215	18.6	\$2267	\$2344	\$2402

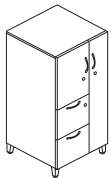

Footed Personal Tower with Metal Fronts, Door/File/File						
50"H x 24"W x 24"D, Wardrobe Left	HSTSF502424LFFM(?) Ⓢ	215	18.6	\$2267	\$2344	\$2402
50"H x 24"W x 24"D, Wardrobe Right	HSTSF502424RFFM(?) Ⓢ	215	18.6	\$2267	\$2344	\$2402

NOTES:

- Metal chassis and drawer fronts.
- Steel frame provides durability.
- Leveling glides can be adjusted from outside or inside the case.
- Heavy-duty, telescoping ball-bearing slides.
- Durable baked enamel finish is applied over rust-inhibiting phosphate pre-treatment.
- Three locks secure doors and drawers.
- Pencil tray standard in top box drawer.
- One box divider standard in each box drawer.
- One crossrail standard in each file drawer.

⚠ Locking units equipped with HON "One Key" interchangeable core removable locks. Keyed alike core model HF23S, in Satin, must be ordered separately. See page 634.

Ⓢ Discontinued 4/6/20.

HOW TO SPECIFY

Select Model Number

Replace (?) with handle choice

- A** Satin Chrome Arch
- N** Full Face Integral
- R** Full Radius

H S T S F 6 5 2 4 2 4 L B B F M A .

Select Paint Color

See page 464 Contain® Storage finish options

P .

Select Lock Option

- L** Standard Lock
- X** Omit Lock (deduct \$60)

L .

Select Foot Color

- T1** Platinum Metallic
- PR6** Silver

T 1



Icon Legend on page 19

Contain® Footed Metal Side Access Towers

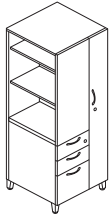

DESCRIPTION

MODEL

SHIP WEIGHT CUBE

LIST PRICE BY PAINT GRADE
P1 P2 P3

DESCRIPTION	MODEL	SHIP WEIGHT	CUBE	P1	P2	P3
Footed Side Access Tower with Metal Fronts, Shelves/Box/Box/File 65"H x 24"W x 24"D, Wardrobe Left	HSTSSF652424LBBFM(?) Ⓢ	255	24.3	\$2573	\$2650	\$2718
65"H x 24"W x 24"D, Wardrobe Right	HSTSSF652424RBBFM(?) Ⓢ	255	24.3	\$2573	\$2650	\$2718

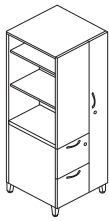

DESCRIPTION	MODEL	SHIP WEIGHT	CUBE	P1	P2	P3
Footed Side Access Tower with Metal Fronts, Shelves/File/File 65"H x 24"W x 24"D, Wardrobe Left	HSTSSF652424LFFM(?) Ⓢ	255	24.3	\$2573	\$2650	\$2718
65"H x 24"W x 24"D, Wardrobe Right	HSTSSF652424RFFM(?) Ⓢ	255	24.3	\$2573	\$2650	\$2718



DESCRIPTION	MODEL	SHIP WEIGHT	CUBE	P1	P2	P3
Footed Side Access Tower with Metal Fronts, Shelves/Box/Box/File 50"H x 24"W x 24"D, Wardrobe Left	HSTSSF502424LBBFM(?) Ⓢ	215	18.6	\$2202	\$2279	\$2337
50"H x 24"W x 24"D, Wardrobe Right	HSTSSF502424RBBFM(?) Ⓢ	215	18.6	\$2202	\$2279	\$2337

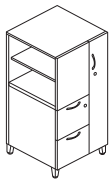

DESCRIPTION	MODEL	SHIP WEIGHT	CUBE	P1	P2	P3
Footed Side Access Tower with Metal Fronts, Shelves/File/File 50"H x 24"W x 24"D, Wardrobe Left	HSTSSF502424LFFM(?) Ⓢ	215	18.6	\$2202	\$2279	\$2337
50"H x 24"W x 24"D, Wardrobe Right	HSTSSF502424RFFM(?) Ⓢ	215	18.6	\$2202	\$2279	\$2337

NOTES:

- A Worksurface to Tower Bracket Kit ships standard with each model.
- Metal chassis and drawer fronts.
- Steel frame provides durability.
- Leveling glides can be adjusted from outside or inside the case.
- Heavy-duty, telescoping ball-bearing slides.
- Durable baked enamel finish is applied over rust-inhibiting phosphate pre-treatment.
- Two locks secure doors and drawers.
- Pencil tray standard in top box drawer.
- One box divider standard in each box drawer.
- One crossrail standard in each file drawer.
- ⓘ Locking units equipped with HON "One Key" interchangeable core removable locks. Keyed alike core model HF23S, in Satin, must be ordered separately. See page 634.
- Ⓢ Discontinued 4/6/20.

HOW TO SPECIFY

<p>Select Model Number</p> <p>Replace (?) with handle choice</p> <p>A Satin Chrome Arch N Full Face Integral R Full Radius</p>	<p>Select Paint Color</p> <p>See page 464 Contain® Storage finish options</p>	<p>Select Lock Option</p> <p>L Standard Lock X Omit Lock (deduct \$60)</p>	<p>Select Foot Color</p> <p>T1 Platinum Metallic PR6 Silver</p>
<p>H S T S S F 6 5 2 4 2 4 L B B F M A .</p>	<p>P .</p>	<p>L .</p>	<p>T 1</p>



Icon Legend on page 19

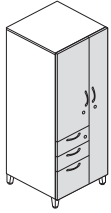

DESCRIPTION	MODEL	SHIP WEIGHT	CUBE	LIST PRICE BY PAINT GRADE		
				P1	P2	P3
Footed Personal Tower with Laminate Fronts, Door/Box/Box/File						
65"H x 24"W x 24"D, Wardrobe Left	HSTSF652424LBBFL(?) Ⓢ	255	24.3	\$3107	\$3184	\$3252
65"H x 24"W x 24"D, Wardrobe Right	HSTSF652424RBBFL(?) Ⓢ	255	24.3	\$3107	\$3184	\$3252

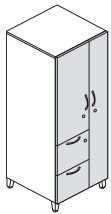

Footed Personal Tower with Laminate Fronts, Door/File/File						
65"H x 24"W x 24"D, Wardrobe Left	HSTSF652424LFFL(?) Ⓢ	255	24.3	\$3107	\$3184	\$3252
65"H x 24"W x 24"D, Wardrobe Right	HSTSF652424RFFL(?) Ⓢ	255	24.3	\$3107	\$3184	\$3252

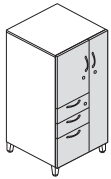

Footed Personal Tower with Laminate Fronts, Door/Box/Box/File						
50"H x 24"W x 24"D, Wardrobe Left	HSTSF502424LBBFL(?) Ⓢ	215	18.6	\$2589	\$2666	\$2724
50"H x 24"W x 24"D, Wardrobe Right	HSTSF502424RBBFL(?) Ⓢ	215	18.6	\$2589	\$2666	\$2724

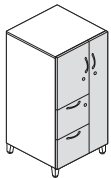

Footed Personal Tower with Laminate Fronts, Door/File/File						
50"H x 24"W x 24"D, Wardrobe Left	HSTSF502424LFFL(?) Ⓢ	215	18.6	\$2589	\$2666	\$2724
50"H x 24"W x 24"D, Wardrobe Right	HSTSF502424RFFL(?) Ⓢ	215	18.6	\$2589	\$2666	\$2724

NOTES:

- Metal chassis with laminate drawer/door fronts.
- Steel frame provides durability.
- Leveling glides can be adjusted from outside or inside the case.
- Heavy-duty, telescoping ball-bearing slides.
- Durable baked enamel finish is applied over rust-inhibiting phosphate pre-treatment.
- Three locks secure doors and drawers.
- Pencil tray standard in top box drawer.
- One box divider standard in each box drawer.
- One crossrail standard in each file drawer.
- ⓘ Available in Satin Chrome Arch only.
- ⓘ Locking units equipped with HON "One Key" interchangeable core removable locks. Keyed alike core model HF23S, in Satin, must be ordered separately. See page 634.

Ⓢ Discontinued 4/6/20.

HOW TO SPECIFY

<p>Select Model Number</p> <p>Replace (?) with handle choice</p> <p>A Satin Chrome Arch</p>	<p>Select Paint Color</p> <p>See page 464 Contain® Storage finish options</p>	<p>Select Lock Option</p> <p>L Standard Lock X Omit Lock (deduct \$60)</p>	<p>Select Laminate Option</p> <p>L1 (no upcharge)</p> <p>COGN Cognac C Harvest N Mahogany MOCH Mocha D Natural Maple PINC Pinnacle F Shaker Cherry</p> <p>L2 (\$35 upcharge)</p> <p>LLA1 Lowell Ash LNRI Natural Recon LPE1 Phantom Ecru LPT1 Portico Teak LSW1 Skyline Walnut</p>	<p>Select Foot Color</p> <p>T1 Platinum Metallic PR6 Silver</p>
<p>H S T S F 6 5 2 4 2 4 L B B F L A .</p>	<p>P .</p>	<p>L .</p>	<p>C .</p>	<p>T 1</p>



Icon Legend on page 19

Contain® Footed Metal Side Access Towers with Laminate Fronts

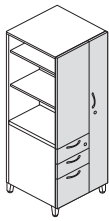

DESCRIPTION	MODEL	SHIP WEIGHT	CUBE	LIST PRICE BY PAINT GRADE		
				P1	P2	P3
Footed Side Access Tower with Laminate Fronts, Shelves/Box/Box/File						
65"H x 24"W x 24"D, Wardrobe Left	HSTSSF652424LBBFL(?) Ⓢ	255	24.3	\$2944	\$3021	\$3089
65"H x 24"W x 24"D, Wardrobe Right	HSTSSF652424RBBFL(?) Ⓢ	255	24.3	\$2944	\$3021	\$3089

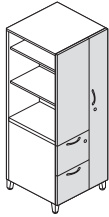

Footed Side Access Tower with Laminate Fronts, Shelves/File/File						
65"H x 24"W x 24"D, Wardrobe Left	HSTSSF652424LFFL(?) Ⓢ	255	24.3	\$2944	\$3021	\$3089
65"H x 24"W x 24"D, Wardrobe Right	HSTSSF652424RFFL(?) Ⓢ	255	24.3	\$2944	\$3021	\$3089

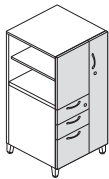

Footed Side Access Tower with Laminate Fronts, Shelves/Box/Box/File						
50"H x 24"W x 24"D, Wardrobe Left	HSTSSF502424LBBFL(?) Ⓢ	215	18.6	\$2524	\$2601	\$2659
50"H x 24"W x 24"D, Wardrobe Right	HSTSSF502424RBBFL(?) Ⓢ	215	18.6	\$2524	\$2601	\$2659

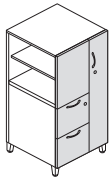

Footed Side Access Tower with Laminate Fronts, Shelves/File/File						
50"H x 24"W x 24"D, Wardrobe Left	HSTSSF502424LFFL(?) Ⓢ	215	18.6	\$2524	\$2601	\$2659
50"H x 24"W x 24"D, Wardrobe Right	HSTSSF502424RFFL(?) Ⓢ	215	18.6	\$2524	\$2601	\$2659

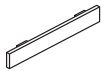

Tower Kickplates (Field Installable)						
For 24" Tower, Left	HSTAKL Ⓢ	2	0.3	\$158	\$166	\$171
For 24" Tower, Right	HSTAKR Ⓢ	2	0.3	\$158	\$166	\$171
Specify: Model.Paint						
SPECIFYING EXAMPLE: HSATKL.P						

NOTES:

- A Worksurface to Tower Bracket Kit ships standard with each model.
- Metal chassis with laminate drawer/door fronts.
- Steel frame provides durability.
- Leveling glides can be adjusted from outside or inside the case.
- Heavy-duty, telescoping ball-bearing slides.
- Durable baked enamel finish is applied over rust-inhibiting phospho pre-treatment.
- Two locks secure doors and drawers.
- Pencil tray standard in top box drawer.

- One box divider standard in each box drawer.
- One crossrail standard in each file drawer.

ⓘ Available in Satin Chrome Arch only.

ⓘ Locking units equipped with HON "One Key" interchangeable core removable locks. Keyed alike core model HF23S, in Satin, must be ordered separately. See page 634.

Ⓢ Discontinued 4/6/20.

HOW TO SPECIFY

<p>Select Model Number</p> <p>Replace (?) with handle choice</p> <p>A Satin Chrome Arch</p>	<p>Select Paint Color</p> <p>See page 464 Contain® Storage finish options</p>	<p>Select Lock Option</p> <p>L Standard Lock X Omit Lock (deduct \$60)</p>	<p>Select Laminate Option</p> <p>L1 (no upcharge) COGN Cognac C Harvest N Mahogany MOCH Mocha D Natural Maple PINC Pinnacle F Shaker Cherry L2 (\$35 upcharge) LLA1 Lowell Ash LNR1 Natural Recon LPE1 Phantom Ecru LPT1 Portico Teak LSW1 Skyline Walnut</p>	<p>Select Foot Color</p> <p>T1 Platinum Metallic PR6 Silver</p>
HSTSSF652424LBBFLA .	P .	L .	C .	T1

EMPOWER[®] Contain[®] Metal Pedestals

GSA SIN 33721



Icon Legend on page 19

WORKSTATIONS

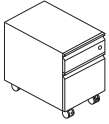

DESCRIPTION	MODEL	SHIP WEIGHT	CUBE	LIST PRICE BY PAINT GRADE		
				P1	P2	P3
Mobile Pedestal with Metal Fronts, Box/File						
21"H x 15"W x 18"D	HSPM211518BFM(?)	63.5	4.4	\$559	\$587	\$615
21"H x 15"W x 24"D	HSPM211524BFM(?)	61.9	5.7	\$599	\$627	\$655

NOTES: Ball-bearing suspension on box and file drawer. (100%) Drawers color to be interior gray steel. See page 529 for Pedestal Seat. File drawer has high sides and back for filing front to back and side to side. Counterweight standard on all mobile peds. Optional steel tops and pedestal seat cushions available. See pages 527 and 530. Pencil tray standard in top box drawer. One box divider standard in each box drawer. One crossrail standard in each file drawer.

- ! Available drawer fronts; R-Pull, A-Pull and N-Pull. A-Pull available in Satin Chrome only.
- ! Peds come with a plinth base, footed base or mobile base.

HOW TO SPECIFY

Select Model Number

Replace (?) with handle choice

- A** Satin Chrome Arch
- N** Full Face Integral
- R** Full Radius

H S P M 2 1 1 5 1 8 B F M A .

Select Paint Color

See page 464 Contain[®] Storage finish options

P .

Select Lock Option

- L** Standard Lock
- X** Omit Lock (deduct \$20)

L



Icon Legend on page 19

EMPOWER® Contain® Footed Metal Pedestals

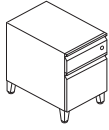

DESCRIPTION

Footed Freestanding Pedestal with Metal Fronts, Box/File

22"H x 15"W x 18"D
22"H x 15"W x 24"D

MODEL

HSPFSF221518BFM(?)
HSPFSF221524BFM(?)

SHIP WEIGHT **CUBE**

66.8 4.4
73.1 5.7

LIST PRICE BY PAINT GRADE

P1	P2	P3
\$656	\$684	\$712
\$694	\$722	\$750

NOTES: Ball-bearing suspension on box and file drawer. (100%) Drawers color to be interior gray steel. File drawer has high sides and back for filing front to back and side to side. Counterweight standard on all mobile peds. Optional steel tops and pedestal seat cushions available. See pages 527 and 530. Pencil tray standard in top box drawer. One box divider standard in each box drawer. One crossrail standard in each file drawer.

- ❗ Available drawer fronts; R-Pull, A-Pull and N-Pull. A-Pull available in Satin Chrome only.
- ❗ Peds come with a plinth base, footed base or mobile base.

DESCRIPTION

Counterweight — Freestanding Support Pedestals or Systems Support and Mobile Pedestals

MODEL	SHIP WEIGHT	CUBE	LIST PRICE
HPCW1	18	0.1	\$195

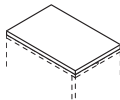

OPEN MARKET

DESCRIPTION

Pedestal Seat
15"W x 22 7/8"D x 2"H

MODEL

HPSEAT24ND

SHIP WEIGHT **CUBE** **FABRIC PRICE CODES**

10 Ⓞ	1.2	1 \$194 8 \$390
		2 \$218 9 \$421
		3 \$242 10 \$452
		4 \$266 11 \$483
		5 \$297 12 \$514
		6 \$328 L —
		7 \$359

NOTES: For seating fabrics, see pages 22-24.
SPECIFYING EXAMPLE: HPSEAT24ND.APN23

DESCRIPTION

Optional Pencil Tray

NOTES: For additional information see page 846.

MODEL **SHIP WEIGHT** **CUBE** **LIST PRICE**

HV-UT1	0.5	0.1	\$66
---------------	-----	-----	------

- ❗ For use with mobile and freestanding pedestal models.
- ❗ No specification required.

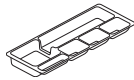

HOW TO SPECIFY

<p>Select Model Number</p> <p>Replace (?) with handle choice</p> <p>A Satin Chrome Arch N Full Face Integral R Full Radius</p> <p>H S P F S F 2 2 1 5 1 8 B F M A .</p>	<p>Select Paint Color</p> <p>See page 464 Contain® Storage finish options</p> <p>P .</p>	<p>Select Lock Option</p> <p>L Standard Lock X Omit Lock (deduct \$20)</p> <p>L .</p>	<p>Select Foot Color</p> <p>T1 Platinum Metallic PR6 Silver</p> <p>T 1</p>
--	--	---	--



Icon Legend on page 19

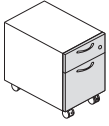

DESCRIPTION	MODEL	SHIP WEIGHT	CUBE	LIST PRICE BY PAINT GRADE		
				P1	P2	P3
Mobile Pedestal with Laminate Fronts, Box/File						
21"H x 15"W x 18"D, Arch Pull	HSPM211518BFL(?)	65.3	4.4	\$715	\$743	\$771
21"H x 15"W x 24"D, Arch Pull	HSPM211524BFL(?)	63.7	5.7	\$755	\$783	\$811

NOTES: Ball-bearing suspension on box and file drawer. (100%) Drawers color to be interior gray steel. File drawer has high sides and back for filing front to back and side to side. Counterweight standard on all mobile peds. See page 529 for Pedestal Seat. Optional pedestal seat cushions available. See page 530. Pencil tray standard in top box drawer. One box divider standard in each box drawer. One crossrail standard in each file drawer.

- ! Drawer Fronts available with Satin Chrome Arch only.
- ! Peds come with a plinth base, footed base or mobile base.

HOW TO SPECIFY

<p>Select Model Number</p> <p>Replace (?) with handle choice</p> <p>A Satin Chrome Arch</p>	<p>Select Paint Color</p> <p>See page 464 Contain® Storage finish options</p>	<p>Select Lock Option</p> <p>L Standard Lock X Omit Lock (deduct \$20)</p>	<p>Select Laminate Option</p> <p>L1 (no upcharge)</p> <p>COGN Cognac C Harvest N Mahogany MOCH Mocha D Natural Maple PINC Pinnacle F Shaker Cherry</p> <p>L2 (\$10 upcharge)</p> <p>LLA1 Lowell Ash LNRI Natural Recon LPE1 Phantom Ecru LPT1 Portico Teak LSW1 Skyline Walnut</p>
<p>H S P M 2 1 1 5 1 8 B F L A .</p>	<p>P .</p>	<p>L .</p>	<p>C</p>



Icon Legend on page 19

Contain® Footed Metal Pedestals with Laminate Fronts

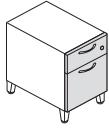

SIN 33721

DESCRIPTION	MODEL	SHIP WEIGHT	CUBE	LIST PRICE BY PAINT GRADE		
				P1	P2	P3
Footed Freestanding Pedestal with Laminate Fronts, Box/File 22"H x 15"W x 18"D, Arch Pull	HSPFSF221518BFL(?)	69.0	4.4	\$812	\$840	\$868
22"H x 15"W x 24"D, Arch Pull	HSPFSF221524BFL(?)	75.3	5.7	\$850	\$878	\$906

NOTES: Ball-bearing suspension on box and file drawer. (100%) Drawers color to be interior gray steel. File drawer has high sides and back for filing front to back and side to side. Counterweight standard on all mobile peds. See below for pedestal seat. Optional pedestal seat cushions available. See page 530. Pencil tray standard in top box drawer. One box divider standard in each box drawer. One crossrail standard in each file drawer. See Brigade® pedestals on page 615 for additional pedestal options. See pages 679-680 for Pedestal Accessories.

- ❗ Drawer Fronts available with Satin Chrome Arch only.
- ❗ Peds come with a plinth base, footed base or mobile base.

HOW TO SPECIFY

<p>Select Model Number</p> <p>Replace (?) with handle choice</p> <p>A Satin Chrome Arch</p>	<p>Select Paint Color</p> <p>See page 464 Contain® Storage finish options</p>	<p>Select Lock Option</p> <p>L Standard Lock X Omit Lock (deduct \$20)</p>	<p>Select Laminate Option</p> <p>L1 (no upcharge)</p> <p>COGN Cognac C Harvest N Mahogany MOCH Mocha D Natural Maple PINC Pinnacle F Shaker Cherry</p> <p>L2 (\$10 upcharge)</p> <p>LLA1 Lowell Ash LNRI Natural Recon LPE1 Phantom Ecrú LPT1 Portico Teak LSW1 Skyline Walnut</p>	<p>Select Foot Color</p> <p>T1 Platinum Metallic PR6 Silver</p>
<div style="display: flex; justify-content: space-between; border: 1px solid black; padding: 2px;"> HSPFSF221518BFLA </div>	<div style="display: flex; justify-content: space-between; border: 1px solid black; padding: 2px;"> P </div>	<div style="display: flex; justify-content: space-between; border: 1px solid black; padding: 2px;"> L </div>	<div style="display: flex; justify-content: space-between; border: 1px solid black; padding: 2px;"> C </div>	<div style="display: flex; justify-content: space-between; border: 1px solid black; padding: 2px;"> T1 </div>

DESCRIPTION	MODEL	SHIP WEIGHT	CUBE	FABRIC PRICE CODES		
Pedestal Seat 15"W x 22 ⁷ / ₈ "D x 2"H	HPSEAT24ND	10 Ⓞ	1.2	1 \$194	8 \$390	
NOTES: For seating fabrics, see pages 22-24.				2 \$218	9 \$421	
				3 \$242	10 \$452	
				4 \$266	11 \$483	
				5 \$297	12 \$514	
				6 \$328	L —	
				7 \$359		

HOW TO SPECIFY

<p>Select Model Number</p>	<p>Select Fabric</p> <p>See pages 462-463 for seating fabric options</p>
<div style="display: flex; justify-content: space-between; border: 1px solid black; padding: 2px;"> HPSEAT24 </div>	<div style="display: flex; justify-content: space-between; border: 1px solid black; padding: 2px;"> APN23 </div>

EMPOWER® Flagship® Mobile Pedestals

GSA SIN AS NOTED



Icon Legend on page 19

WORKSTATIONS



H15923N

SIN 33721

DESCRIPTION	MODEL	SHIP WEIGHT	CUBE	LIST PRICE BY PAINT GRADE		
				P1	P2	P3
Mobile Pedestals — Box/File 15"W x 22 ⁷ / ₈ "D x 22"H NOTES: Pencil tray standard in top box drawer. One box divider standard in each box drawer. One crossrail standard in each file drawer. File drawers have high sides for filing front-to-back. Steel ball-bearing suspension on file and box drawers. See pages 679-680 for accessories and pedestal utilization information. Arch pull available in Satin Chrome only. Choose from any of three pull options with no upcharge. Available in Arch (A), Full Face Integral (N) and Full Radius (R) Drawer Pulls. See page 612 for pull options. Equipped with HON "One Key" interchangeable core removable locks. Counterweight standard. Omit lock-option available. See page 853 for ordering instructions. See Brigade® pedestals on page 615 for additional pedestal options. See pages 679-680 for Pedestal Accessories.	H15923(?)	92	6.0	\$569	\$597	\$625

HOW TO SPECIFY

Select Model Number A Satin Chrome Arch N Full Face Integral R Full Radius H 1 5 9 2 3 A .	Select Lock Option L Lock (no upcharge) X Omit Lock (deduct \$20) X .	Select Paint Color See page 464 T 1
---	---	--

DESCRIPTION	MODEL	SHIP WEIGHT	CUBE	FABRIC PRICE CODES		
Pedestal Seat 15"W x 22 ⁷ / ₈ "D x 2"H NOTES: For seating fabrics, see pages 22-24.	HPSEAT24ND	10	1.2	1 \$194	8 \$390	
				2 \$218	9 \$421	
				3 \$242	10 \$452	
				4 \$266	11 \$483	
				5 \$297	12 \$514	
				6 \$328	L —	
				7 \$359		



HOW TO SPECIFY

Select Model Number H P S E A T 2 4 .	Select Fabric See pages 462-463 for seating fabric options A P N 2 3
---	---

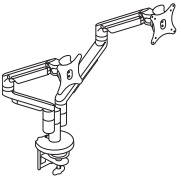
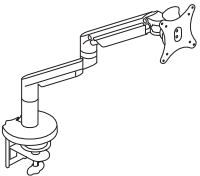
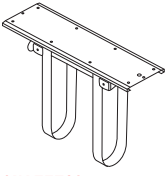

Icon Legend on page 19

	DESCRIPTION	MODEL	SHIP WEIGHT	CUBE	LIST PRICE
	<p>Dual Dynamic Monitor Arm</p> <ul style="list-style-type: none"> • 150° of rotation at base with optional 360° rotation. • Arms extend 22" and retract up to 3". • Monitor mount rotates 180° and tilts +/-30°. • Monitor can be rotated from landscape to portrait position. <p>! Arms hold monitors from 6.2-18 lbs. Optional counterweight HPACW available to support monitors as low as 5 lbs. (see page 827).</p>	HMASD	17.0 Ⓢ	1.1	\$750
	<p>Single Dynamic Monitor Arm</p> <ul style="list-style-type: none"> • 180° of rotation at base with optional 360° rotation. • Arms extend 22" and retract up to 3". • Monitor mount rotates 180° and tilts +/-30°. • Monitor can be rotated from landscape to portrait position. <p>! Arms hold monitors from 6.2-18 lbs. Optional counterweight HPACW available to support monitors as low as 5 lbs. (see page 827).</p>	HMASTS	11.5 Ⓢ	0.8	\$390
	<p>360° Swivel CPU Holder with Adjustable Straps</p> <ul style="list-style-type: none"> • Supports CPUs 3¾" wide up to 64" perimeter and holds up to 75 lbs. • 360° rotation. • Ships complete and includes necessary mounting hardware and instruction sheet. <p>! Available in Black only, no specification needed.</p>	HCPU1	7.0 Ⓢ	0.2	\$243

SIN 33721

NOTES:

- For additional information see pages 825-827.



Monitor Arms

- Arms fold back to post to allow more desktop room.
- Arms feature double extension, allowing 20"+ of back and forth movement.
- Cable management on both pole and arm assemblies.
- Counterbalance adjustment provides stability for monitors up to 17.6 lbs per arm.
- Made of high quality aluminum alloy material.
- See pages 825-826 for additional monitor arm models.

HOW TO SPECIFY

<p>Select Model Number</p>	<p>Select Finish</p> <p><i>Specify for models HMASD and HMASTS only</i></p> <p>SVR Silver BLK Black</p>
<p>HMASD</p>	<p>SVR</p>

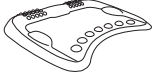
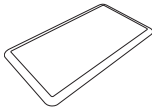
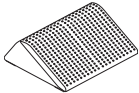

	DESCRIPTION	MODEL	SHIP WEIGHT	CUBE	LIST PRICE
	Rectangle Wobble Board — Anti-Fatigue Mat 18"D x 3"H x 22½"W ⓘ Available in Black (T) finish ONLY. Recommended weight capacity not to exceed 250 pounds. HON 5-Year Limited Warranty. SPECIFYING EXAMPLE: HVL981.T	HVL981	10.0 ⓘ	0.9	\$120
	Round Wobble Board — Anti-Fatigue Mat 18½"D x 2½"H x 18½"W ⓘ Available in Black (T) finish ONLY. Recommended weight capacity not to exceed 250 pounds. HON 5-Year Limited Warranty. SPECIFYING EXAMPLE: HVL982.T	HVL982	5.8 ⓘ	0.6	\$102
	Ergonomic Anti-Fatigue Mat 25"D x 2¾"H x 29⅞"W ⓘ Available in Black ONLY. No specification needed. SPECIFYING EXAMPLE: HBEAFM1	HBEAFM1	7.0	1.4	\$219
	Rectangle Anti-Fatigue Mat 20"D x ¾"H x 36"W ⓘ Available in Black ONLY. No specification needed. SPECIFYING EXAMPLE: HBAFM2036	HBAFM2036	5.4	0.4	\$100
	Footrest — Anti-Slip Cover 13¾"D x 5½"H x 16"W ⓘ Available in Black (T) finish ONLY. Recommended weight capacity not to exceed 250 pounds. HON 5-Year Limited Warranty. SPECIFYING EXAMPLE: HVL991.T	HVL991	7.0 ⓘ	0.9	\$82

HOW TO SPECIFY

<p>Select Model Number</p> <p>H V L 9 8 1 .</p>	<p>Select Finish</p> <p>T Black</p> <p>T</p>
---	--

SYSTEMS SHARED COMPONENTS



Systems Worksurfaces, Accelerate® Panels, Systems Overhead Storage, Voi® O-Legs and Storage shown with Lota® Task Chairs.

SYSTEMS SHARED COMPONENTS

Panel-based workstations make efficient use of space, giving your people a place of their own that's still part of the action. Modular components are easy to specify and install, so you can configure them just about any which way — and reconfigure fast when your needs change. Systems models integrate seamlessly with Abode, Abound, Accelerate, Empower and Voi models and can be configured to create freestanding or height adjustable workstations.

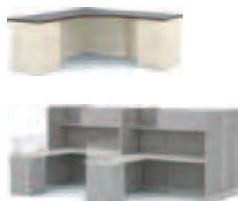

FEATURES

- Systems worksurfaces and supports can be used with Abode, Abound, Accelerate, Coordinate, Empower and Voi products.
- Systems electrical and data components can be used with Abode, Abound, Accelerate and Empower products.
- Systems storage can be used with Abound and Accelerate products.

SYSTEMS OVERHEAD AND SHELVES SPECIFYING

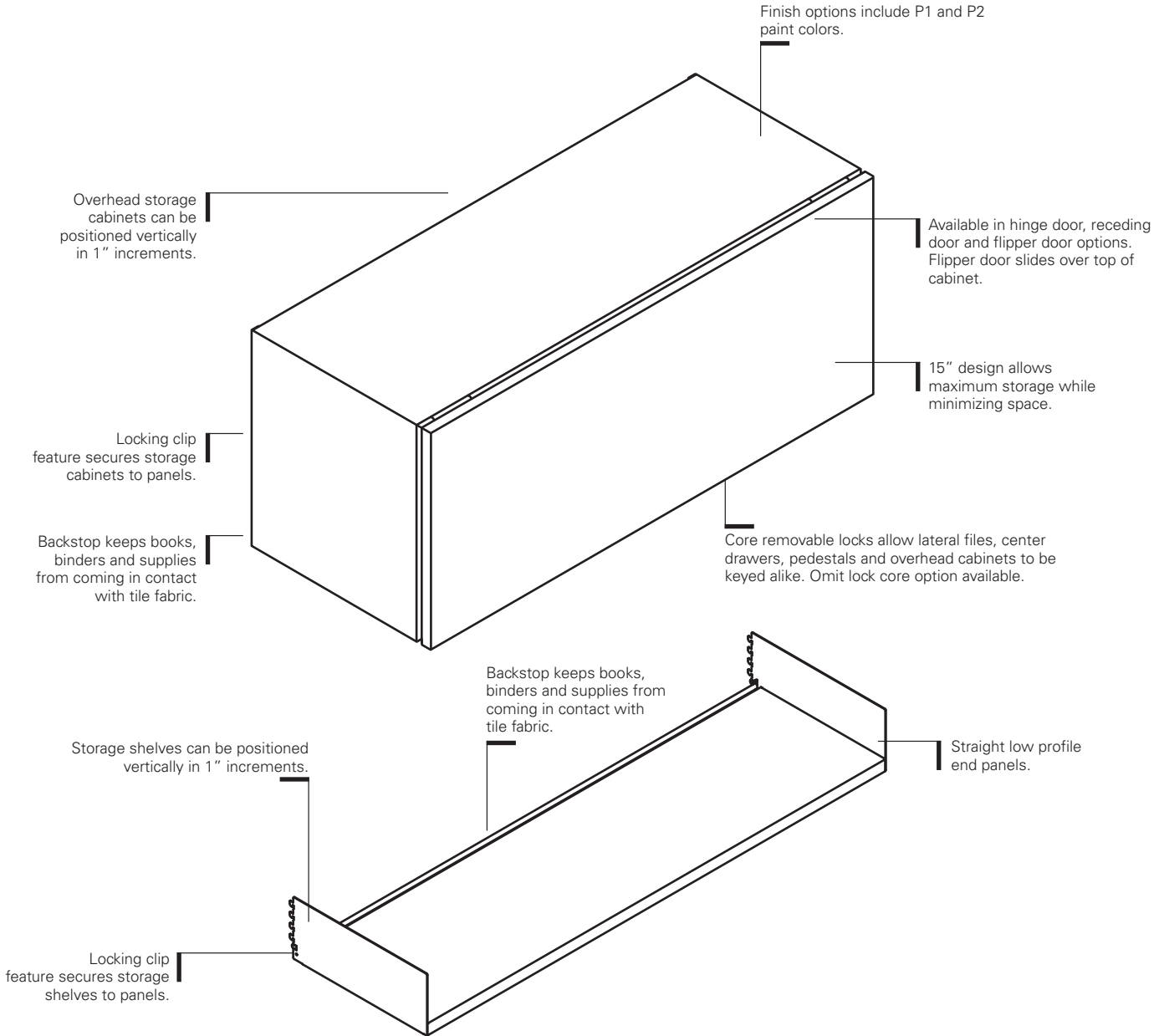

PRODUCT DIMENSIONS

Overhead Storage Cabinet

Width 24", 30", 36", 42", 48", 60"

Inside width Flipper and Receding door — $\frac{3}{8}$ " less than width
Hinged door — $1\frac{3}{4}$ " less than width

Depth $14\frac{7}{8}$ "

Inside depth $12\frac{7}{8}$ "

Height 15"

Inside height $12\frac{3}{4}$ "

Open Shelf

Width 24", 30", 36", 42", 48", 60"

Depth $14\frac{3}{8}$ "

Height $5\frac{5}{8}$ "

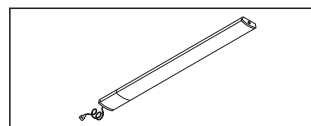

Task lights can be mounted beneath storage shelves and overhead storage cabinets.

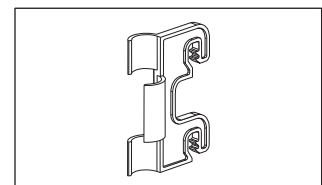

Cord retainer clips fasten into panel slots to anchor power cords. Available in black only. Clips are provided with undershelf mounted task lights.

SYSTEMS OVERHEAD AND SHELVES SPECIFYING

SPECIFICATION GUIDELINES

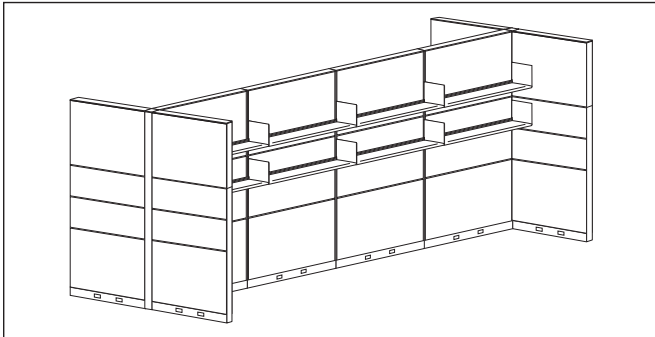

In a panel run, only two overhead storage cabinets or open storage shelves are recommended per panel side. When suspending overhead storage off-module only one storage unit per panel side is allowed.

When overhead storage units are suspended from stacking frames, the following guidelines should be adhered to:

A maximum of two overhead storage units can be suspended from each side of stacking frames on any given panel.

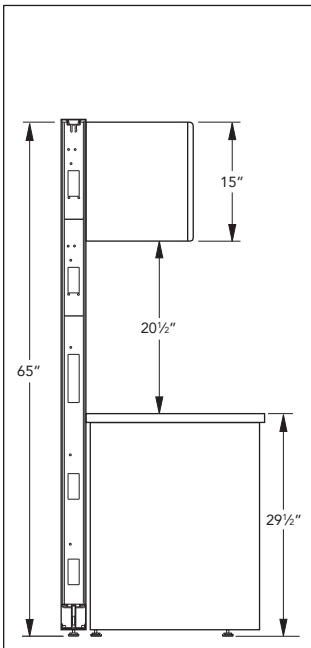

Overhead Storage cabinets and the **Open Shelf** can also be mounted to a maximum height of 65"H on all systems. Voi overheads not to be mounted on Accelerate stackers.

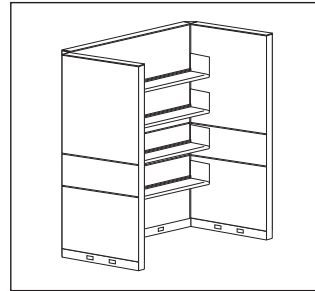

No limitation to the number of units on structural frames when units are spaced 12" apart and when the run is supported with return panels of equal height to the spine wall on each side of storage shelves or overhead storage cabinets.

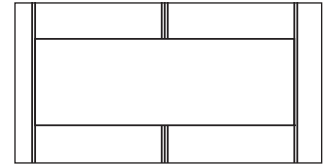

Storage shelf and overhead width must correspond with width of panel(s). It is possible to span two panels when combined panel width equals cabinet or shelf width.

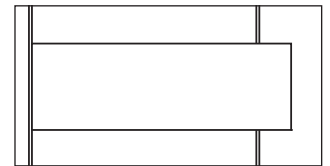

Overhead Cabinets can be mounted on a panel equal to or up to 18" narrower than cabinet.

Not applicable for ETA overheads, Voi overheads, and shelves.

SYSTEMS

Overhead and Shelves

GSA SIN 33721



Icon Legend on page 19

WORKSTATIONS

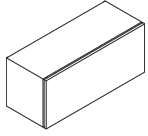

DESCRIPTION

Metal Flipper Door Overheads

24"W x 14³/₈"D x 15"H
 30"W x 14³/₈"D x 15"H
 36"W x 14³/₈"D x 15"H
 42"W x 14³/₈"D x 15"H
 48"W x 14³/₈"D x 15"H
 60"W x 14³/₈"D x 15"H
 72"W x 14³/₈"D x 15"H

MODEL

HRVOH24FM
HRVOH30FM
HRVOH36FM
HRVOH42FM
HRVOH48FM
HRVOH60FM
HRVOH72FM

SHIP WEIGHT

35
 38
 41
 46
 52
 62
 82

CUBE

3.6
 4.4
 5.3
 6.1
 6.9
 8.6
 10.6

LIST PRICE BY PAINT GRADE

P1 P2

\$542 **\$591**
\$552 **\$601**
\$577 **\$626**
\$605 **\$654**
\$632 **\$681**
\$833 **\$882**
\$955 **\$1004**

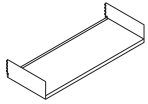

Open Shelf

24"W x 14³/₈"D x 5⁵/₈"H
 30"W x 14³/₈"D x 5⁵/₈"H
 36"W x 14³/₈"D x 5⁵/₈"H
 42"W x 14³/₈"D x 5⁵/₈"H
 48"W x 14³/₈"D x 5⁵/₈"H
 60"W x 14³/₈"D x 5⁵/₈"H
 72"W x 14³/₈"D x 5⁵/₈"H

HRVSH24
HRVSH30
HRVSH36
HRVSH42
HRVSH48
HRVSH60
HRVSH72

13 **Ⓞ**
 15 **Ⓞ**
 16 **Ⓞ**
 17 **Ⓞ**
 18 **Ⓞ**
 20
 32

1.2
 1.5
 1.8
 1.9
 2.3
 2.9
 3.6

\$233 **\$250**
\$253 **\$270**
\$269 **\$286**
\$279 **\$296**
\$291 **\$308**
\$357 **\$374**
\$466 **\$483**

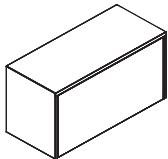

Receding Door Overhead

30"W x 13³/₈"D x 15"H
 36"W x 13³/₈"D x 15"H
 42"W x 13³/₈"D x 15"H
 48"W x 13³/₈"D x 15"H
 60"W x 13³/₈"D x 15"H

HRVOH1530RM
HRVOH1536RM
HRVOH1542RM
HRVOH1548RM
HRVOH1560RM

38
 41
 46
 52
 62

5.7
 6.8
 7.8
 8.9
 11.2

\$699 **\$752**
\$737 **\$790**
\$784 **\$837**
\$849 **\$902**
\$1287 **\$1340**

NOTES:

- Overhead Storage Cabinets with doors are standard with a factory installed core removable lock located on the underside of the cabinet.
- All units feature an anti-dislodgement device.
- 60" and 72"W units are one piece cabinet with two doors.
- Upmount kits can be used with all metal overheads.

! Keyed alike cores must be ordered separately — see page 853.

HOW TO SPECIFY

Select Model Number

HRVOH24FM

Select Paint Color

See page 441

T4







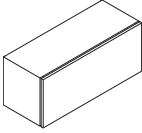
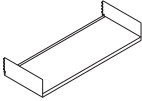

Select Lock Option

- L Lock
 - X Omit Lock (deduct \$20) (where applicable)
- See page 853



L



SYSTEMS ETA Overheads and Shelves

	DESCRIPTION	MODEL	SHIP WEIGHT	CUBE	LIST PRICE BY PAINT GRADE	
					P1	P2
	Flipper Door Overheads					
	24"W x 13"D x 15"H	HEOHRTA1524FD	21	1.6	\$426	\$475
	30"W x 13"D x 15"H	HEOHRTA1530FD	24	1.6	\$433	\$482
	36"W x 13"D x 15"H	HEOHRTA1536FD	27	1.6	\$454	\$503
	42"W x 13"D x 15"H	HEOHRTA1542FD	30	1.8	\$476	\$525
	48"W x 13"D x 15"H	HEOHRTA1548FD	33	2.1	\$496	\$545
	60"W x 13"D x 15"H	HEOHRTA1560FD	42	2.5	\$655	\$704
72"W x 13"D x 15"H	HEOHRTA1572FD	49	3.0	\$813	\$862	
	Open Shelves					
	24"W x 13"D x 5 5/8"H	HESHRTA24	10 	1.9	\$199	\$216
	30"W x 13"D x 5 5/8"H	HESHRTA30	11 	1.9	\$215	\$232
	36"W x 13"D x 5 5/8"H	HESHRTA36	12 	1.9	\$229	\$246
	42"W x 13"D x 5 5/8"H	HESHRTA42	13 	2.1	\$237	\$254
	48"W x 13"D x 5 5/8"H	HESHRTA48	14 	2.4	\$249	\$266
	60"W x 13"D x 5 5/8"H	HESHRTA60	16 	3.0	\$303	\$320
72"W x 13"D x 5 5/8"H	HESHRTA72	18 	3.5	\$358	\$375	

NOTES:

- Storage Cabinets with doors are standard with a factory installed core removable lock located on the underside of the cabinet.
 - All units feature an anti-dislodgement device.
 - Accepts under cabinet lighting.
 - ETA overheads and shelves ship flat packed.
 - Only one installer is needed to assemble an ETA overhead on a panel (all sizes).
 - Attachment brackets are attached to the back of the unit (included).
 - ETA overheads and shelves are slightly less deep than built-up models. Please note when using next to built-up models.
 - Order overhead and shelf to match the width of panel being used.
-  Keyed alike cores must be ordered separately — see page 853.
-  Cannot be used in off-modular applications because attachment bracket is attached to the back of the case and cannot be moved.

HOW TO SPECIFY

Select Model Number	Select Paint Color
	See page 441
H E O H R T A 1 5 2 4 F D .	T 1

SYSTEMS

Overhead Storage

GSA SIN 33721



Icon Legend on page 19

WORKSTATIONS

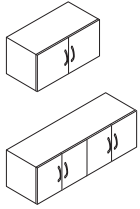

DESCRIPTION

Steel Front Hinged Door Overhead with Arch Pull

24"W x 15"D x 15"H
30"W x 15"D x 15"H
36"W x 15"D x 15"H
42"W x 15"D x 15"H
48"W x 15"D x 15"H

MODEL

HRVOHV24HMA
HRVOHV30HMA
HRVOHV36HMA
HRVOHV42HMA
HRVOHV48HMA

SHIP WEIGHT

32
36
42
52
56

CUBE

5.6
6.8
7.7
8.1
9.2

LIST PRICE BY PAINT GRADE

P1 P2

\$731 \$780
\$757 \$806
\$783 \$832
\$809 \$858
\$839 \$888

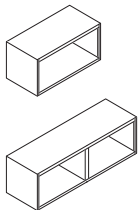

Open Storage Cabinet

24"W x 15"D x 15"H
30"W x 15"D x 15"H
36"W x 15"D x 15"H
42"W x 15"D x 15"H
48"W x 15"D x 15"H

HRVSHV24
HRVSHV30
HRVSHV36
HRVSHV42
HRVSHV48

21
26
29
32
37

5.6
6.8
7.7
8.1
9.2

\$666 \$715
\$689 \$738
\$716 \$765
\$743 \$792
\$771 \$820

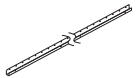

Abound®/Accelerate® Horizontal Wall Track for Overhead Storage

60"W

HTWTH

5

0.8

\$83

N/A

NOTES: Use when mounting overhead storage and when a permanent wall hanger kit is not desired. For 72"W overheads, use two wall tracks cut to 36".

ⓘ Cannot be used with ETA storage or Voi®. Can only be used with systems flipper door, receding door and hinged door overheads.

NOTES:

- Overhead Storage Cabinets with doors are standard with a factory installed core removable lock located on the underside of the cabinet.
- Upmount kits can be used with all metal overheads.

ⓘ Keyed alike cores must be ordered separately — see page 853.

HOW TO SPECIFY

Select Model Number

Select the Pull

A Satin Chrome Arch

HRVOHV24HMA

Select Lock Option

L Lock
X Omit Lock (deduct \$20) (where applicable)
See page 853

L

Select Paint Color

See page 441

T4



Icon Legend on page 19

Laminate Front Overhead Storage

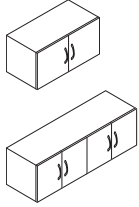

DESCRIPTION	MODEL	SHIP WEIGHT	CUBE	LIST PRICE BY PAINT GRADE	
				P1	P2
Laminate Front Hinged Door Overheads with Arch Pull					
24"W x 15"D x 15"H	HRVOHV24HLA	35	5.6	\$899	\$948
30"W x 15"D x 15"H	HRVOHV30HLA	40	6.8	\$925	\$974
36"W x 15"D x 15"H	HRVOHV36HLA	48	7.7	\$952	\$1001
42"W x 15"D x 15"H	HRVOHV42HLA	53	8.1	\$979	\$1028
48"W x 15"D x 15"H	HRVOHV48HLA	64	9.2	\$1004	\$1053

NOTES:

- Unit features metal chassis and laminate doors.
- Laminate fronts are available in L1 woodgrain only.
- Overhead Storage Cabinets with doors are standard with a factory installed core removable lock located on the underside of the cabinet.
- Upmount kits can be used with all metal overheads.

! Keyed alike cores must be ordered separately — see page 853.

HOW TO SPECIFY

<p>Select Model Number</p> <p>Select the Pull</p> <p>A Satin Chrome Arch</p>	<p>Select Lock Option</p> <p>L Lock X Omit Lock (deduct \$20) See page 853</p>	<p>Select Front Laminate Color</p> <p>L1 Woodgrain only See page 441</p>	<p>Select Case Paint Color</p> <p>See page 441</p>
<p>H R V O H V 2 4 H L A .</p>	<p>L .</p>	<p>H .</p>	<p>T 4</p>

VOI® Overhead Storage

GSA SIN 33721



Icon Legend on page 19

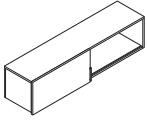

DESCRIPTION	MODEL	SHIP WEIGHT	CUBE	L1 LIST	L2 UPCHARGES	
					CABINET	DOOR
Overhead Cabinet with One Sliding Door						
36"W x 14¼"D x 14"H	HLSL1436S	39	9.7	\$999	\$25	\$20
42"W x 14¼"D x 14"H	HLSL1442S	48	9.7	\$1047	\$25	\$20
48"W x 14¼"D x 14"H	HLSL1448S	57	12.1	\$1078	\$25	\$20
60"W x 14¼"D x 14"H	HLSL1460S	69	13.3	\$1161	\$30	\$25
66"W x 14¼"D x 14"H	HLSL1466S	83	14.6	\$1282	\$30	\$25
72"W x 14¼"D x 14"H	HLSL1472S	95	15.9	\$1400	\$35	\$25

NOTES: Only available in laminate.

ⓘ Overhead and Stack-on storage units do not lock.

NOTES:

- Voi® Overhead Storage can be used with Accelerate® and Abound® panels.
- All Overhead Cabinets shown above and on next page can be used as a wall mount, panel mount or stack-on storage with O-leg.
- Can be mounted on O-legs, panel brackets or wall mount brackets. See page 542.
- are available for wall mount storage applications.
- Sliding door overhead does not ship with a pull — door overhangs chassis to slide.
- Overhead cabinets with four doors are available in laminate or mixed materials.
- For all color specifying combinations, see matrix on page 171.
- Storage cases accept binder height items.
- Storage cube fits inside stack-on storage or overhead cabinet units to provide paper management.
- Wall mount brackets specified with unit. Brackets attach to case horizontally.
- For panel mounted applications, brackets and hardware are ordered separately, see page 587. Brackets attach to panel and case is screwed into brackets. Two brackets needed for 60" unit; three brackets needed for 66" and larger.
- If Wall Bracket option is selected, \$150 upcharge applies.
- For additional information see page 844.

ⓘ Stack-on Storage must be placed over two full-height supports. Cannot be placed over non-supported sections such as returns using a flat bracket or tower-to-worksurface bracket.

HOW TO SPECIFY

<p>Select Model Number</p> <p>For locking overhead models, add an "L" suffix (\$40 upcharge per model)</p> <p>H L S L 1 4 7 2 S .</p>	<p>Select Cabinet Laminate</p> <p>See page 171</p> <p>N .</p>	<p>Select Door Laminate</p> <p>See page 171</p> <p>N .</p>	<p>Select Pull</p> <p>X No Pull</p> <p>X .</p>	<p>Specify Bracket Option</p> <p>X No Bracket W Wall Bracket (\$150 upcharge)</p> <p>W</p>
--	--	---	---	---

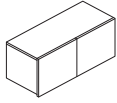

DESCRIPTION

Overhead Cabinet with Doors

36"W x 14¼"D x 14"H, 2 doors
 42"W x 14¼"D x 14"H, 2 doors
 48"W x 14¼"D x 14"H, 3 doors
 60"W x 14¼"D x 14"H, 4 doors

MODEL	SHIP WEIGHT	CUBE	L1 LIST	L2 UPCHARGES	
				CABINET	DOOR
HLSL1436D	39	9.7	\$842	\$25	\$20
HLSL1442D	48	9.7	\$937	\$25	\$20
HLSL1448D	57	12.1	\$1040	\$25	\$30
HLSL1460D	115	13.3	\$1161	\$30	N/A

❗ 2-Door and 3-Door Overhead Cabinet with Doors models HLSL1436D – HLSL1448D available in laminate only. The 60" model HLSL1460D is available in all door finish options—see "Select Door Material for 2/3/4 Door Models" below.

❗ Overhead and Stack-on storage units do not lock.

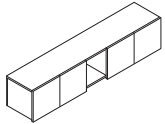

Overhead Cabinet with 4 Doors/Cubbies

66"W x 14¼"D x 14"H with 6" Cubbie
 72"W x 14¼"D x 14"H with 12" Cubbie

HLSL1466D	126	14.6	\$1282	\$30	\$30
HLSL1472D	139	15.9	\$1400	\$35	\$35

NOTES: Doors available in laminate or mixed materials.

NOTES:

- Voi® Overhead Storage can be used with Accelerate® and Abound® panels.
- All Overhead Cabinets shown above and on previous page can be used as a wall mount, panel mount or stack-on storage with O-leg.
- Can be mounted on O-legs, panel brackets or wall mount brackets. See page 542.
- are available for wall mount storage applications.
- Overhead cabinets with four doors are available in laminate or mixed materials.
- For all color specifying combinations, see matrix on page 171.
- Storage cases accept binder height items.
- Storage cube fits inside stack-on storage or overhead cabinet units to provide paper management.
- Wall mount brackets specified with unit. Brackets attach to case horizontally.
- For panel mounted applications, brackets and hardware are ordered separately, see page 587. Brackets attach to panel and case is screwed into brackets. Two brackets needed for 60" unit.
- If Wall Bracket option is selected, \$150 upcharge applies.
- ❗ Stack-on Storage must be placed over two full-height supports. Cannot be placed over non-supported sections such as returns using a flat bracket or tower-to-worksurface bracket.
- ❗ 1TG doors not available with a locking option.

HOW TO SPECIFY

<p>Select Model Number</p> <p>For locking overhead models, add an "L" suffix (\$40 upcharge per model)</p> <p>H L S L 1 4 6 0 D</p>	<p>Select Cabinet Laminate</p> <p>See page 171</p> <p>N</p>	<p>Select Door Material for 2/3/4 Door Models</p> <p>Upcharges for door selection: 4-Door \$315</p> <p>1TG Platinum Polymer with Frosted Glass</p> <p>Also available in laminate doors. See page 171.</p> <p>Not specified for models HLSL1436D – HLSL1448D. These models are available in laminate only.</p> <p>1TG</p>	<p>Select Bracket Option</p> <p>X No Bracket W Wall Bracket (\$150 upcharge)</p> <p>X</p>
---	---	---	--

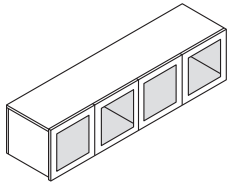

DESCRIPTION	MODEL	SHIP WEIGHT	CUBE	LIST PRICE BY LAMINATE GRADE	
				L1	L2
Overhead Cabinet with 4 Frosted, Metal Frame Doors 60"W x 14¼"D x 14"H ⓘ Must specify an X or W for attachment bracket option below.	HLSL1460M	115	11.4	\$1893	\$1923

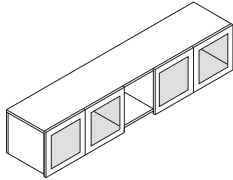

Overhead Cabinet with 4 Frosted, Metal Frame Doors 72"W x 14¼"D x 14"H with 12" Cubbie ⓘ Must specify an X or W for attachment bracket option below.	HLSL1472M	139	13.6	\$2134	\$2169
66"W x 14¼"D x 14"H with 6" Cubbie	HLSL1466M	126	12.5	\$2013	\$2043



Storage Cube 12"W x 12"D NOTES: For additional information see page 846. SPECIFYING EXAMPLE: HLSL1212.P8S	HLSL1212	1	0.3	\$294	N/A
--	-----------------	---	-----	--------------	------------

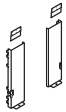

DESCRIPTION	MODEL	SHIP WEIGHT	CUBE	LIST PRICE BY PAINT GRADE	
				P1	P2
Voi® for Systems Stack-on Storage Panel Mounted Bracket Used to panel mount stack-on storage units Specify paint NOTES: Ships with one set of three brackets, which includes one right, one center and one left bracket. When using a 60"W overhead on a 60"W panel or a 72"W overhead on a 72"W panel, only two of the three brackets provided are required. SPECIFYING EXAMPLE: HLSLPMB.T1	HLSLPMB	3 ⓘ	1.0	\$131	\$141

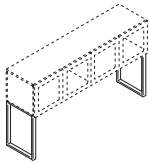

O-Leg Support for Overhead Cabinet Ships 2/pack 14⅞"D x 20½"H for 65"H Overhead Cabinet 14⅞"D x 5½"H for 50"H Overhead Cabinet	HLSL650S	8	1.1	\$468	\$472
	HLSL500S	6	1.0	\$390	\$394

NOTES:

- Voi® Overhead Storage can be used with Accelerate® and Abound® panels.
- Overhead and Stack-on storage units do not lock.
- Use O-Leg Support models for Overhead Cabinets.
- If Wall Bracket option is selected, \$150 upcharge applies.
- Storage cube fits inside stack-on storage or wall mount units to provide paper management.
- Storage Cubes are available in the following colors: Atom (P8S), Bullseye (PJF), Ember (P8P), Ion (P8N), Iris (P8J), Krypton (P8F), and Regatta (P8M).

ⓘ Stack-on Storage must be placed over two full-height supports. Cannot be placed over non-supported sections such as returns using a flat bracket or tower-to-worksurface bracket.

HOW TO SPECIFY

Select Model Number HLSL1460M . N .	Select Cabinet Laminate See page 171	Select Door Material TIG Platinum Metal Doors with Frosted Glass (no upcharge)	Select Bracket Option X No Bracket W Wall Bracket (\$150 upcharge)
---	--	--	---



Shared Overhead Storage Components

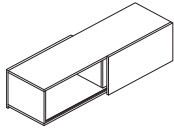

DESCRIPTION

Shared Overhead Storage — Left
 60"W x 17"D x 14"H
 72"W x 17"D x 14"H

MODEL	SHIP WEIGHT	CUBE	L1 LIST	L2 UPCHARGES	
				CABINET	DOOR
HLSL1760SOL	115	14.8	\$1277	\$20	\$40
HLSL1772SOL	139	17.0	\$1539	\$25	\$40

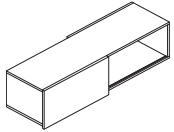

Shared Overhead Storage — Right
 60"W x 17"D x 14"H
 72"W x 17"D x 14"H

HLSL1760SOR	115	14.8	\$1277	\$20	\$40
HLSL1772SOR	139	17.0	\$1539	\$25	\$40



DESCRIPTION

Post Legs for Shared Storage
 14"H Post Legs
 22"H Post Legs

MODEL	SHIP WEIGHT	CUBE	LIST PRICE BY PAINT GRADE	
			P1	P2
HLSL140SPL	10	1.1	\$339	\$343
HLSL220SPL	13	3.7	\$375	\$379

NOTES: 14"H post legs on worksurfaces will span 35"H panel or shorter. 14"H post legs on low credenzas will span 30"H panel or shorter. 22"H post legs on worksurfaces will span 50"H panel or shorter. 22"H post legs on low credenzas will span 35"H panel or shorter. Specify paint.

SPECIFYING EXAMPLE: HLSL140SPL.T4



Panel Mount Bracket for Shared Overhead

Panel Mount Bracket for Overhead Storage — Accelerate®
 Panel Mount Bracket for Overhead Storage — Abound®
 Panel Mount Bracket for Overhead Storage — Accelerate®/Abound® 42½"H panels only

HLSLPMBSOA	4	0.1	\$136	\$140
HLSLPMBSOB	4	0.1	\$136	\$140
HLSLPMBSO42	4	0.1	\$127	\$131

NOTES: Specify paint.

SPECIFYING EXAMPLE: HLSLPMBSOA.T4

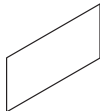

for Shared Storage
 30"W x 15"D for use with 60"W Shared Overhead
 36"W x 15"D for use with 72"W Shared Overhead

HLSL1530SOMB	6	1.0	\$132	
HLSL1536SOMB	8	1.0	\$179	

NOTES: No specification necessary.

HOW TO SPECIFY

<p>Select Model Number</p> <p>HLSL1760SOL .</p>	<p>Select Chassis Laminate</p> <p>See page 171</p> <p>N .</p>	<p>Select Door Front Laminate</p> <p>See page 171</p> <p>N .</p>	<p>Select Pull Color</p> <p>T4 Champagne Metallic T1 Platinum Metallic WHIT White</p> <p>T4</p>
--	--	---	--

<p>Select Model Number</p> <p>HLSL140SPL .</p> <p>HLSLPMBSOA .</p>	<p>Select Paint Color</p> <p>See page 171</p> <p>T4</p> <p>T4</p>
---	--

SYSTEMS

Overhead and Shelves

GSA SIN 33721



Icon Legend on page 19

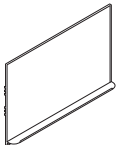

DESCRIPTION

36"W x 24"H
42"W x 24"H
48"W x 24"H

MODEL

HHMRK36
HHMRK42
HHMRK48

SHIP WEIGHT

15
17
19

CUBE

3.2
4.0
4.6

LIST PRICE

\$509
\$553
\$595

NOTES:

- Brushed aluminum finish around low-glare porcelain coated steel magnetic writing surface.
- Brushed aluminum marker tray attaches to frame.
- Width of must correspond to the width of the panel.
- will attach to the Abound and Accelerate® frame with brackets provided.
- Able to use multiple next to each other and multiple boards per panel.

No color specification required.

Porcelain cleaning instructions: For everyday cleaning, use Chlorox wipes. Use citrus cleaner if a permanent marker is used by accident. A citrus cleaner is not recommended for everyday use as it leaves residue.

HOW TO SPECIFY

Select Model Number

H H M R K 3 6

DESCRIPTION

20"W x 18"H
24"W x 18"H
30"W x 18"H
36"W x 18"H
42"W x 18"H
48"W x 18"H
60"W x 18"H
72"W x 18"H

MODEL

HETB2018
HETB2418
HETB3018
HETB3618
HETB4218
HETB4818
HETB6018
HETB7218

SHIP WEIGHT

2
3
3
8
10
12
13
15

CUBE

0.5
0.6
0.7
0.9
1.0
1.2
1.5
1.8

LIST PRICE

\$103
\$128
\$149
\$169
\$189
\$207
\$231
\$253

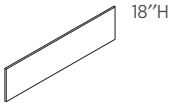

SPECIFYING EXAMPLE: HETB2018.APN15

NOTES:

- Works with both Abound® and Accelerate® panel systems.
- Specify fabric, see pages 392-393 for fabric options.

HOW TO SPECIFY

Select Model Number

H E T B 2 0 1 8 .

Select Fabric Color

A P N 1 5

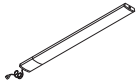

DESCRIPTION	MODEL	SHIP WEIGHT	CUBE	LIST PRICE
LED Task Lights				
17" LED Light with Power Supply (Single)	HLED17AS	1.2 Ⓔ	0.05	\$420
31" LED Light with Power Supply (Single)	HLED31AS	1.5 Ⓔ	0.09	\$565
17" LED Light with Power Supply for Daisy-chain (Starter)	HLED17A	1.0 Ⓔ	0.05	\$462
31" LED Light with Power Supply for Daisy-chain (Starter)	HLED31A	1.4 Ⓔ	0.09	\$620
17" LED Light with 8" Jumper Cord for Daisy-chain (Follower)	HLED17AUO	1.0 Ⓔ	0.03	\$377
31" LED Light with 8" Jumper Cord for Daisy-chain (Follower)	HLED31AUO	1.0 Ⓔ	0.05	\$502
Undercabinet Occupancy Sensor with 1" End to End Connector	HLEDOSA	0.2 Ⓔ	0.01	\$89

NOTES: To use the daisy chain application, must start with model HLED17A or HLED31A. No finish specification required. Attaches magnetically to underside of overhead storage, or attaches with provided screws or double-sided tape. Occupancy sensor attaches to a single or starter LED light and will automatically turn the light off after no motion is detected for 30 minutes. Just like all the LED light models, the occupancy sensor features a soft-touch on/off switch. LED task lights have a lifetime of 50,000 hours and have a dimmer feature that allows the user to adjust the amount of light output. For additional information see page 842.

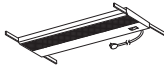

DESCRIPTION	MODEL	SHIP WEIGHT	CUBE	BASIC (NO SUFFIX REQUIRED)	CHICAGO CODE "CH"
Task Lights					
<ul style="list-style-type: none"> Slim profile design mounts recessed under storage unit and shelves with spring steel clips. T5 bulb included which contains less mercury than other types of bulbs. 9-foot black cord and switch off right rear corner. Electronic ballast for increased energy efficiency. 2 lights (HH870930) can be mounted under 60"W storage cabinets. 					
For 24"W storage cabinets or shelves, 18 ³ / ₈ "W x 3 ¹ / ₁₆ "D x 1 ¹ / ₈ "H	HH870924(?)	5.0 Ⓔ	0.4	\$227	\$287
For 30"W and 36"W storage cabinets or shelves, 22 ¹ / ₈ "W x 3 ¹ / ₁₆ "D x 1 ¹ / ₈ "H	HH870930(?)	7.0 Ⓔ	0.6	\$231	\$301
For 42"W and 48"W storage cabinets or shelves, 34 ⁵ / ₈ "W x 3 ¹ / ₁₆ "D x 1 ¹ / ₈ "H	HH870942(?)	10.0 Ⓔ	0.9	\$250	\$317
For 60"W and 72"W storage cabinets or shelves, 46 ¹ / ₂ "W x 3 ¹ / ₁₆ "D x 1 ¹ / ₈ "H	HH870960(?)	12.0 Ⓔ	1.1	\$270	\$337

NOTES: For additional information see page 842.

! Color: Black.

Chicago Code Version — Specify: Model/"CH". EXAMPLE: HH870924CH

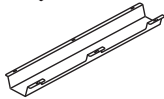
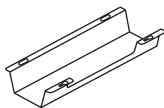

SIN 33721

DESCRIPTION	MODEL	SHIP WEIGHT	CUBE	LIST PRICE
Cable Management Troughs				
17"W — Single	HCTROUGH17	2.7 Ⓔ	0.5	\$67
17"W — 10-Pack	HCTROUGH1710	14.0 Ⓔ	0.5	\$620
36"W — Single	HCTROUGH36	4.9 Ⓔ	0.9	\$113
36"W — 10-Pack	HCTROUGH3610	30.0 Ⓔ	0.9	\$1045

- Cable management troughs ship flat packed.
- The troughs attach to underneath the worksurface with screws.
- The 17"W has one wire access cut out on the user side. The 36" has two wire access cut outs. These cut outs give users access to inside the trough without having to detach it from the worksurface.
- Color: Graphite.
- Material: Metal.
- TAA Compliant.

NOTES: For additional information see page 852.

SYSTEMS Accessories

GSA SIN 33721



Icon Legend on page 19

WORKSTATIONS

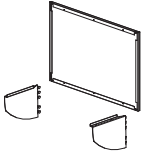

DESCRIPTION	MODEL	SHIP WEIGHT	CUBE	LIST PRICE BY PAINT GRADE	
				P1	P2
Upmount Kits for Overheads					
24"W	HRVUP24	7.0	0.3	\$155	\$173
30"W	HRVUP30	8.0	0.3	\$162	\$180
36"W	HRVUP36	10.0	0.4	\$167	\$185
42"W	HRVUP42	11.0	0.4	\$176	\$194
48"W	HRVUP48	12.0	0.5	\$183	\$201
60"W	HRVUP60	16.0	0.6	\$196	\$214

- Includes two upmount brackets, full back panel and installation hardware.
- Brackets require a clearance of 6½" below bottom of overhead cabinet.
- Full back panel adds ½" to depth of overhead case.

ⓘ Kit width must correspond to the width of the overhead case.

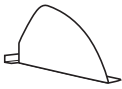

Overhead Shelf Dividers Shelf Dividers — package of 6	H38SHFDV	3.0 Ⓞ	0.2	\$145	\$156
---	-----------------	-------	-----	--------------	--------------

Specify paint

NOTES:

- Upmount Bracket allows mounting of Overhead Cabinet up to 15" above height of panel.
- Upmount Kits for overheads can be used with flipper or receding door overheads. See page 536.

ⓘ Upmount Kits not for use on Accelerate stackers.

HOW TO SPECIFY

Select Model Number	Select Paint Color
	See page 441
H 3 8 S H F D V .	T 1

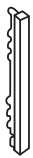

DESCRIPTION	MODEL	SHIP WEIGHT	CUBE	LIST PRICE BY PAINT GRADE	
				P1	P2
Cord Cover					
• Allows routing of task light cords.					
• Vertical height 10".	HECC10	0.7 Ⓞ	0.2	\$38	\$45
• Vertical height 15".	HECC15	1.0 Ⓞ	0.3	\$38	\$45
• Cord cover can be positioned into panel slots and used under task lights and under worksurfaces.					

Specify paint

HOW TO SPECIFY

Select Model Number	Select Paint Color
	See page 441
H E C C 1 0 .	T 1

ABOUND® Electrical and Data

WORKSTATIONS

Abound® features capabilities for cable management, including electrical, voice, and data. The 8-wire electrical system can be integrated at base pathway and beltline. The open structure of the frame allows voice and data cables to be routed both vertically and horizontally.

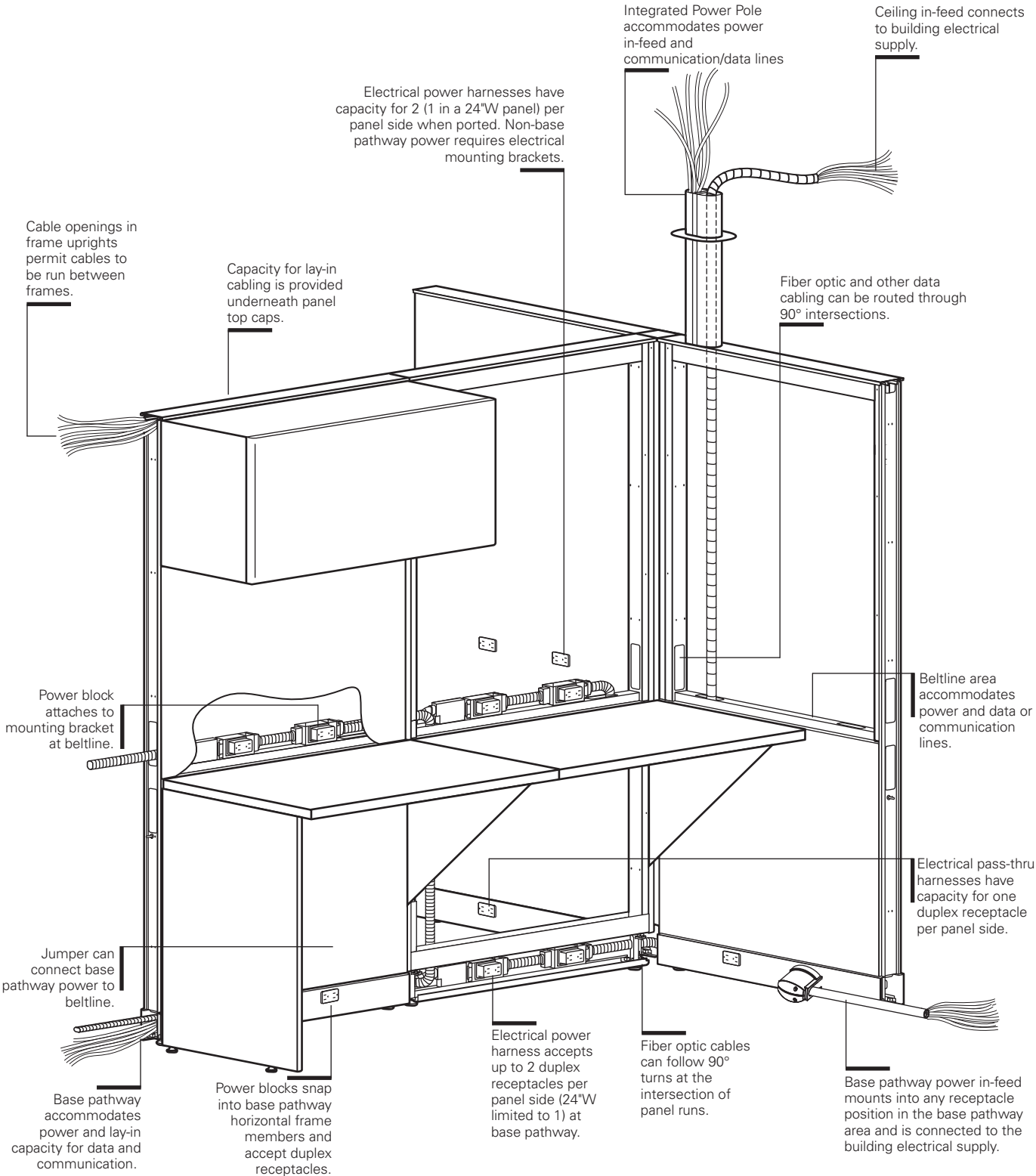

ABOUND® Electrical and Data

THE ABOUND ELECTRICAL SYSTEMS

Abound offers a choice of three electrical systems:

- Four-circuit, 3 + 1
- Four-circuit, 2 + 2
- Three-circuit, separate neutrals

All three systems utilize an 8-wire electrical system, rated at 20 amps per circuit (15 amps Canadian). See pages 553-554 for a detailed explanation of each electrical system.

Abound frames and electrical components are UL Listed. Electrical components are also CSA certified.

Installation and use of the electrical system, the number of receptacles used on a given circuit and connections to the building power supply should be in compliance with all local and national electrical codes.

Caution: Electrical equipment cords or extension cords MUST NOT BE ROUTED through cable openings in frame sides.

Abound's electrical harnesses are UL listed and are considered raceways themselves as defined by the National Electrical Code. This means there is no separation requirement between the electrical harnesses and communications cables per Sec. 800-52 of the National Electrical Code. Communication cables may be placed next to Abound's electrical components without a metal septum and will still meet the guidelines of the Telecommunications Industry Association for separation of power and data.

IN-FEEDS

Power in-feed cables deliver power from building to system. In-feed cables are housed in conduit to separate electrical system from communications and data lines.

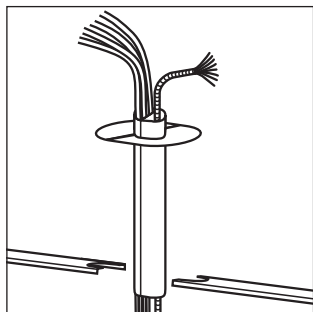

Integrated power and communications poles provide capacity for routing power supply directly through the top of any structural or stacking frame using same width trim/connector kit in place of top cap. Avoid glass or translucent tiles in upper position of frames with integrated power poles. Power pole has a cavity on each side of a center septum. When using a ceiling power in-feed, consider that the in-feed must connect into an electrical harness located in an adjacent panel. (See pages 555-556 for cable capacity.)

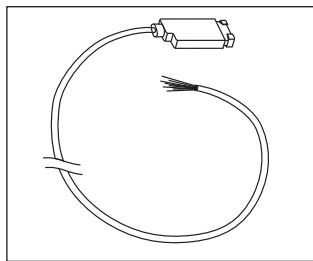

Ceiling power in-feed connects to a prewired electrical harness in the beltline or base pathway, traverses through an adjacent panel and terminates in the junction box at the top of the integrated power pole. For use with integrated power pole models HEP65 and HEP35. No portion of the flex cable can be exposed after installation.

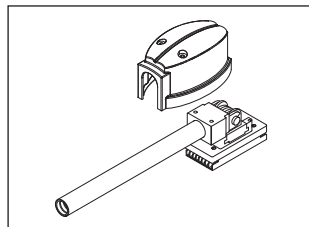

Sealtight base pathway power in-feed attaches to a receptacle opening at the base pathway. A heavy rubber sheathing shields conduit, allowing in-feed to be exposed.

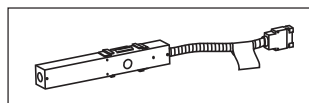

Hardwire (New York Code) power in-feed (model H871400) is used when local electrical codes require hardwire entry. When used in 24"W, 30"W and 36"W panels, power can be routed only in one direction. When used in 42", 48"W and 60"W panels, an electrical pass-thru cable or harness for that panel width can be used to route power back in the opposite direction. Unit must connect to a power or pass-thru harness positioned in the base pathway area of an adjacent panel. Customer to furnish all cabling and wiring from power entry to power source. Junction box can be positioned at any duplex receptacle location.

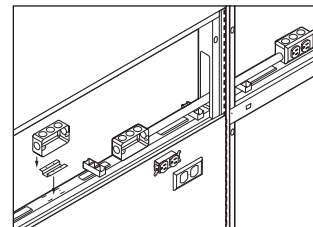

HARDWIRE (CHICAGO CODE) JUNCTION BOX

Wiring harnesses and snap connectors are not allowed in Chicago — base pathways must be comprised of all metallic components. Concealed mounting is the only option at beltline. For the base pathway, junction box (model HH873500) clips directly into receptacle locations. Customer must furnish conduit, wiring, standard duplex receptacles with metal covers for the beltline and designer-type receptacles for the base pathway. Power entry can be routed from the ceiling, via an Abound power pole, or from the floor into a junction box (model HH873500).

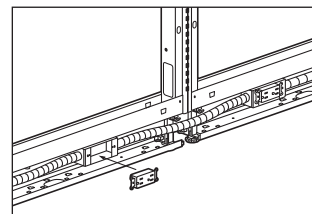

POWER

Power blocks on electrical power harness and pass-thru harness accept duplex receptacles.

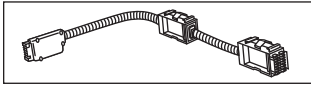

Electrical power harnesses are used to distribute power in panels. Abound electrical can be located at base pathway or beltline only. Connectors at both ends of power harnesses allow power distribution in either direction.

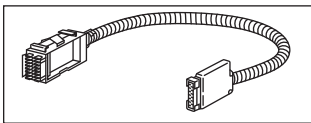

Electrical pass-thru harnesses have capacity to handle one duplex receptacle on each side of the panel when exposed.

A 60" pass-thru harness can be used to jump up to a single duplex receptacle per side at beltline and connecting to a power harness at base pathway.

Electrical power harnesses and pass-thru cables cannot be routed at 90° at beltline once frames are connected to connector blocks.

Electrical pass-thru cables distribute power through any panel where receptacles are not required. Cable length cannot be stretched.

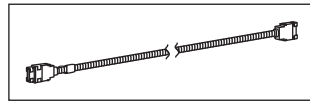

Electrical jumper cables connect power from base pathway or beltline to a harness located on any horizontal member as needed. Jumper cable plugs into power block end of electrical power harness or electrical pass-thru harness.

Model HH871366 is 66" to jump up to 30 inches vertically – base pathway to beltline or beltline to base pathway.

Jumper can also be used from beltline to adjacent beltline at 90° juncture.

POWER BLOCKS

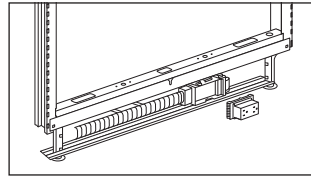

Base pathway mounting: Power blocks snap directly onto brackets in base pathway area.

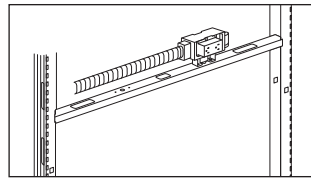

Beltline electrical mounting: For ported receptacles at beltline mount power blocks onto Electrical Mounting Brackets which screw into the panel frame. Electrical Mounting Brackets must be ordered separately. Data/Electrical Port Tiles must be used where exposed receptacles will be located.

RECEPTACLES

Duplex receptacles snap into power blocks of power harnesses or pass-through harnesses. Duplexes are available in multiple colors. Each receptacle is labeled to indicate which circuit it will be connected to.

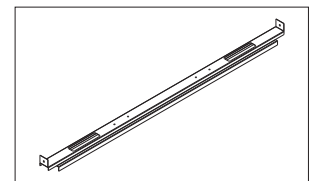
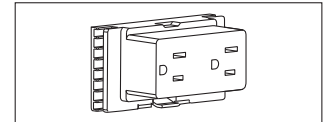

OPTIONAL STIFFENER SUPPORT Stiffener supports can be used to provide additional rigidity to a panel when fabric tiles are on both sides of the frame. May also be used for routing power/data at non-standard heights.

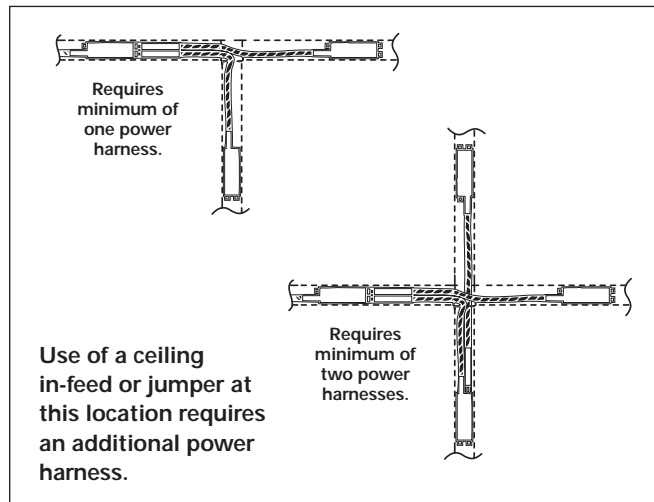

All electrical power harnesses and pass-thru harnesses will stretch 3½", allowing them to span "T" and "X" intersections and "S" extended straight connections.

ACCELERATE® Electrical and Data

Accelerate® features capabilities for cable management, including electrical, voice, and data. The 8-wire electrical system can be integrated at base pathway. See Systems electrical pages 558-564 for electrical models to be used with Accelerate® Systems products. See page 409 for Abound® frame horizontal and vertical wire capacity and page 556 for base pathway capacity.

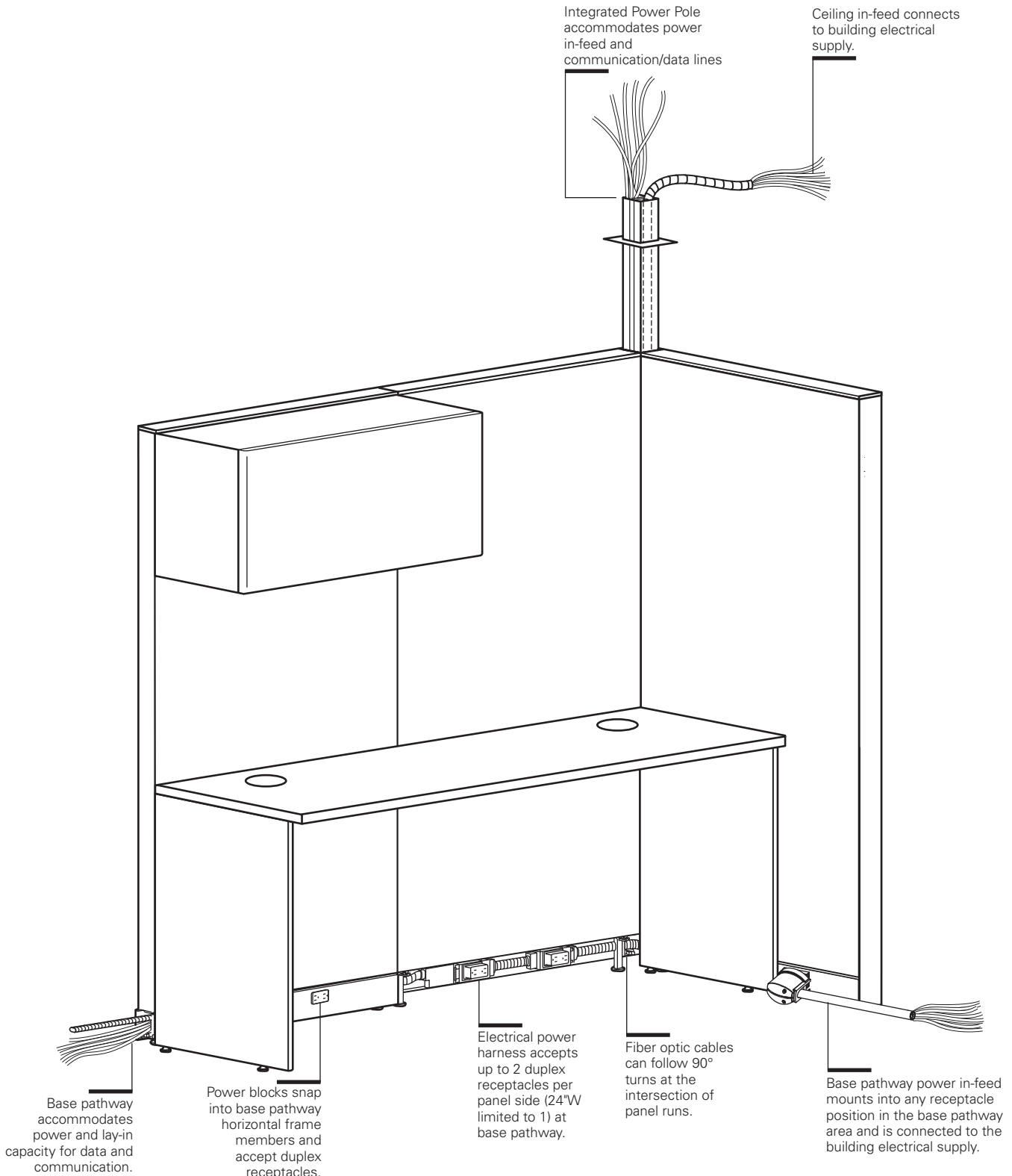

THE ACCELERATE ELECTRICAL SYSTEMS

Accelerate offers a choice of three electrical systems:

- Four-circuit, 3 + 1
- Four-circuit, 2 + 2
- Three-circuit, separate neutrals

All three systems utilize an 8-wire electrical system, rated at 20 amps per circuit (15 amps Canadian). See pages 553-554 for a detailed explanation of each electrical system.

Accelerate panels and electrical components are UL Listed. Electrical components are also CSA certified.

Installation and use of the electrical system, the number of receptacles used on a given circuit and connections to the building power supply should be in compliance with all local and national electrical codes.

Caution: Electrical equipment cords or extension cords MUST NOT BE ROUTED through cable openings in frame sides.

Accelerate's electrical harnesses are UL listed and are considered raceways themselves as defined by the National Electrical Code. This means there is no separation requirement between the electrical harnesses and communications cables per Sec. 800-52 of the National Electrical Code. Communication cables may be placed next to Accelerate's electrical components without a metal septum and will still meet the guidelines of the Telecommunications Industry Association for separation of power and data.

IN-FEEDS

Power in-feed cables deliver power from building to system. In-feed cables are housed in conduit to separate electrical system from communications and data lines.

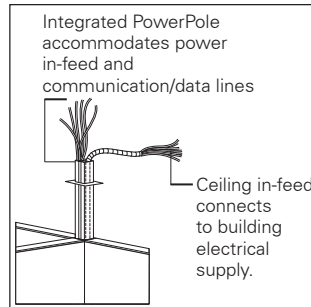

Integrated power and communications poles provide capacity for routing power supply directly through the top of any connector. When using a ceiling power in-feed, consider that the in-feed must connect into an electrical harness located in an adjacent panel. (See pages 555-556 for cable capacity.)

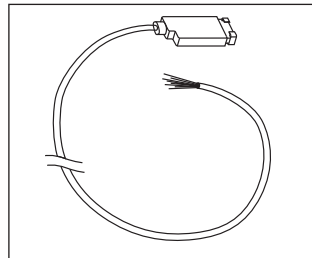

Ceiling power in-feed connects to a prewired electrical harness in the beltline or base pathway, traverses through an adjacent panel and terminates in the junction box at the top of the integrated power pole. For use with integrated power pole models HECPP. No portion of the flex cable can be exposed after installation.

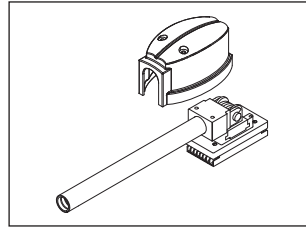

Sealtight base pathway power in-feed attaches to a receptacle opening at the base pathway. A heavy rubber sheathing shields conduit, allowing in-feed to be exposed.

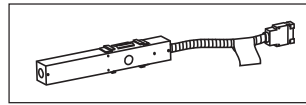

Hardwire (New York Code) power in-feed (model H871400) is used when local electrical codes require hardwire entry. When used in 24"W, 30"W and 36"W panels, power can be routed only in one direction. When used in 42", 48"W and 60"W panels, an electrical pass-thru cable or harness for that panel width can be used to route power back in the opposite direction. Unit must connect to a power or pass-thru harness positioned in the base pathway area of an adjacent panel. Customer to furnish all cabling and wiring from power entry to power source. Junction box can be positioned at any duplex receptacle location.

HARDWIRE (CHICAGO CODE) JUNCTION BOX

Wiring harnesses and snap connectors are not allowed in Chicago — base pathways must be comprised of all metallic components. Concealed mounting is the only option at beltline. For the base pathway, junction box (model HH871500) clips directly into receptacle locations. Customer must furnish conduit, wiring, standard duplex receptacles with metal covers for the beltline and designer-type receptacles for the base pathway. Power entry can be routed from the ceiling, via an Accelerate power pole, or from the floor into a junction box (model HH871500). See Systems electrical pages 558-564 for electrical models to be used with Accelerate® Systems products.

DUPLEX RECEPTACLES

For Duplex Receptacle models that can be used on Accelerate® panel systems, please see page 561.

All Systems electrical components can be found on pages 558-564.

SYSTEMS

Electrical and Data

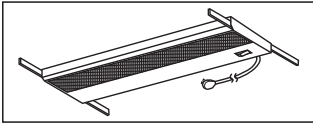

LIGHTING

Task lights can be recessed under storage cabinets or storage shelves.

Task lights in four sizes are available to correspond to cabinet or shelf width. They have 9' power cords in black, connected in the right rear corner. All models feature electronic ballast for longer bulb life and cooler operating temperature. Task lights with a fused plug to meet Chicago electrical code are also available.

Recommendation: Provide a separate circuit for task lights for proper long-term operation without RF interference to computers that may be in use.

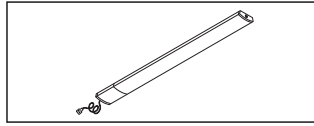

LED TASK LIGHTS

No finish specification required. Attaches magnetically to underside of overhead storage, or attaches with provided screws.

Occupancy sensor attaches to a single or starter LED light and will automatically turn the light off after no motion is detected for 30 minutes.

Just like all the LED light models, the occupancy sensor features a soft-touch on/off switch. LED task lights have a lifetime of 50,000 hours and have a dimmer feature that allows the user to adjust the amount of light output.

Daisy chain options are available. To use the daisy chain application, must start with model HLED17A or HLED31A.

VOICE/DATA RECEPTACLES

Abound not only provides space for large volumes of voice and data cables, it also offers several means of mounting commercially available voice and data components.

Commercially available modular data faceplates can be mounted in vacant base receptacle openings or can be mounted in data/electrical port tiles above or below the worksurface.

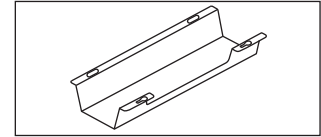

Cable management troughs attach to worksurfaces with provided screws. The graphite metal troughs are designed with cord access cut outs. These cut outs give users access to inside the trough without having to detach it from the worksurface.

SYSTEMS ELECTRICAL SPECIFYING INFORMATION

To Order:

1. Determine which electrical system you will use after consulting your electrician and computer support personnel:
 - **The Four-circuit system (4-Hot/2-Neutral/2-Ground)**
 - 3 + 1 option
 - 2 + 2 option
 - **The Three-circuit system (3-Hot/3-Neutral/2-Ground)**
2. Determine location, quantity and circuit of duplexes.
3. Determine the appropriate choice and use of Isolated, Isolated/Dedicated and Separate Neutral circuits.
4. Specify appropriate Power Harnesses* and Pass-Thru Cables.*
5. Determine the location, quantity and type of Power In-feed needed.

* Select Power Harness models (HH8712XX) and Pass-Thru Cables (HH8711XX) with the last two digits being 1" (or 2") smaller than the associate panel width.

Electrical System Options

The four-circuit, eight-wire electrical system is widely specified and trusted by hundreds of thousands of end-users. This proven system delivers four circuits for every power in-feed in either a 3 + 1 or 2 + 2 configuration. The isolated/dedicated circuits are ideal for sensitive computing equipment, while the common circuits are suitable for faxes, copiers, task lights and other peripherals.

Both the 3 + 1 and 2 + 2 systems use the same pre-wired components, making it easy to adjust as electrical needs change.

You can also choose a three-circuit, eight-wire system that has a dedicated neutral for every hot circuit. The three-circuit components have model numbers with an "A" suffix and appear in a gray box in this pricer.

Four-circuit, 3 + 1 Receptacle Option

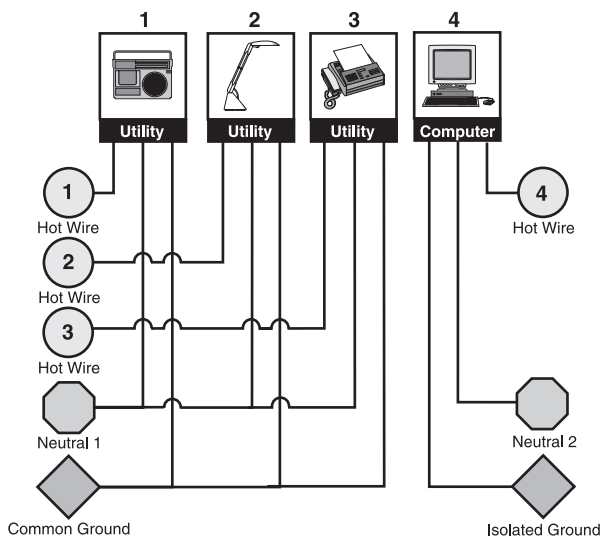

The 3 + 1 option is the electrical standard used by The HON Company for many years in most of their systems products. This wiring option provides three utility circuits plus an isolated/dedicated circuit for more sensitive equipment.

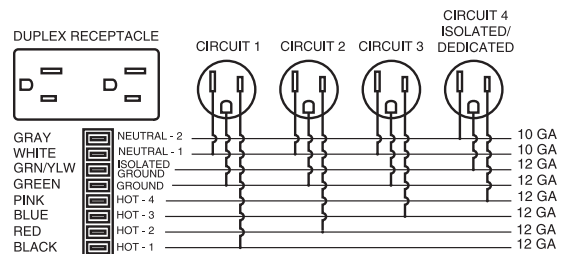

Four-circuit, 2 + 2 Receptacle Option

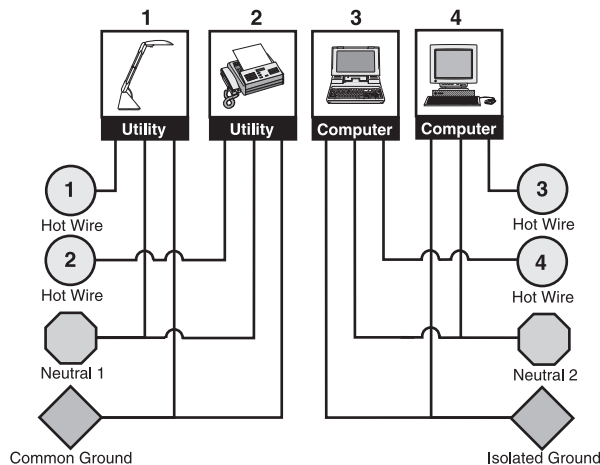

The 2 + 2 option is a wiring option that provides two utility circuits and two isolated circuits for more extensive computer usage applications.

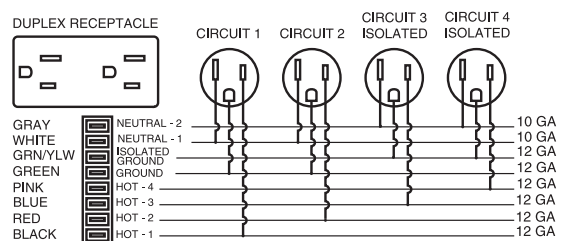

SYSTEMS ELECTRICAL SPECIFYING INFORMATION

Three-circuit, separate neutrals

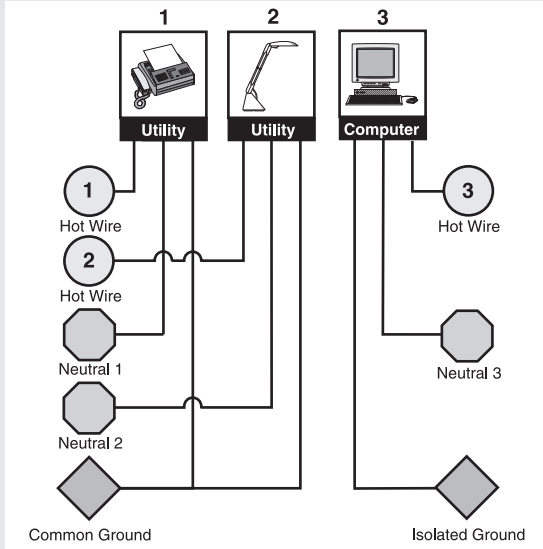

The Three-circuit, separate neutrals configuration is a wiring option that provides separate neutrals for each of the three circuits. Two circuits share a common ground, and one circuit is isolated/dedicated. The three-circuit components have model numbers with an "A" suffix and appear in a gray box in this pricer.

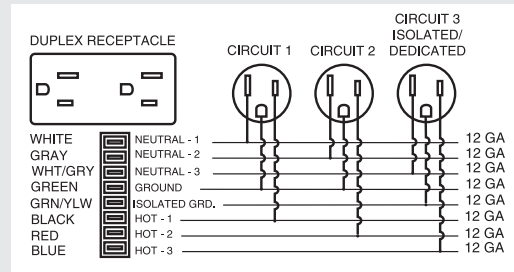

Two 8-wire, 20 AMP (15 AMP Canadian) electrical systems are offered					
Electrical System	Circuitry	Receptacle Capacity			
Four-circuit 4-Hot/2-Neutral/2-Ground (10 gauge neutral wires)	3 + 1	Common Circuit-1 HH873501	Common Circuit-2 (1) HH873502	Common Circuit-3 HH873503	Iso/Dedicated Circuit-4 HH873504
	2 + 2	Common Circuit-1 HH873501	Common Circuit-2 HH873502	Isolated Circuit-3 HH873506	Isolated Circuit-4 HH873504
Three-circuit 3-Hot/3-Neutral/2-Ground (12 gauge neutral wires)	w/separate neutrals	Common Circuit-1 HH873501A	Common Circuit-2 HH873502A	Iso/Dedicated Circuit-3 HH873503A	N/A

(1) Circuit-2 (one of the 3 common circuits sharing a neutral wire) cannot be used with a single-phase building electrical supply.

Notes:

- Four-circuit components and three-circuit components (with suffix "A") cannot be used together.
- Components of the two systems are keyed differently to prevent components of one system from being connected to components of another system.
- HON Cat. Nos. are printed on the UL labels, and components are color-coded to provide visual identification of the different components.
- Four-circuit components have black plastic parts.
- Three-circuit components have rust-colored terminal ends and receptacle backs are rust colored.

Typical power usage by the most commonly specified office equipment.

Source: Industry Analysis, Inc., Rochester, NY

EQUIPMENT	AMPS	EQUIPMENT	AMPS	EQUIPMENT	AMPS
Computers		Copiers		FAX Machines	
Personal Computer	3	Desktop Copier	15	InkJet FAX	less than 1
Notebook Computer	3	Console Copier	20	Thermal FAX	less than 1
		Copier/Duplicator	30	Plain paper FAX	8
Monitors		Printers		Task Lights	
13" Color Monitor	2	Dot Matrix	less than 1	36" T8 Fluorescent	0.2/bulb
17" Color Monitor	3	InkJet	less than 1	48" T8 Fluorescent	0.3/bulb
21" Color Monitor	4	Personal Laser or LED	8		
		Workgroup Laser or LED	15		

Duplex Receptacles



15 AMP Receptacle

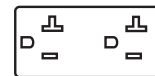

20 AMP Receptacle
(Required by some large copiers.)

SYSTEMS ELECTRICAL SPECIFYING INFORMATION

- Abound and Accelerate panels are UL listed.
- Electrical components are UL Listed and CSA Certified.
- It is the customer's responsibility to ensure that use of the pre-wired electrical system, the number of receptacles used on a given circuit, and connection to a building power source, be in compliance with all local and national electrical codes.
- Contact Customer Service for additional information.
- Pedestals and Lateral Files, positioned under worksurfaces, may render some receptacles inaccessible, and may prohibit use of grommets.
- Four-circuit components and Three-circuit components (with suffix "A") cannot be used together. See pages 553-554.
- Three-way panel connections require at least one power harness.
- 4-way panel connections require at least two power harnesses.
- ! A licensed electrician must make connections to a building electrical supply.

Definition of components:

Electrical Power Harness

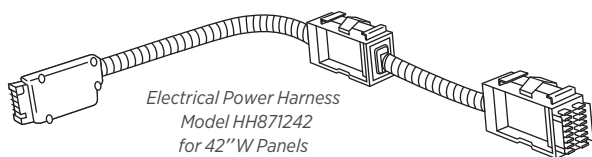

- Used to distribute power in panels.
- Power distribution in either direction.
- Specify Power Harness to match panel width.
- Double-sided: receptacles can be inserted into both sides of Power Blocks.

- ! Three-way panel connections require at least one power harness.
- ! 4-way panel connections require at least two power harnesses.

Electrical Pass-Thru Cables

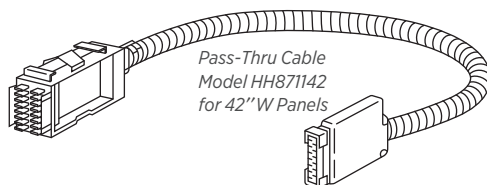

Pass-Thru Cable With Duplex Capacity:

- Use in panels where multiple receptacles are not required.
- Added feature: has capacity for one receptacle on each side of a panel. Feature offers future expansion and is an alternative to Power Harnesses.

Various Electrical Layouts



Straight Line

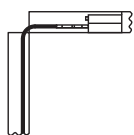

90 Degree Corner

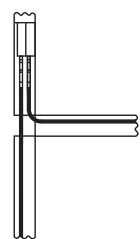

"T" Connection

When ending power in two return panels, wiring pigtails must be returned to original panel run.

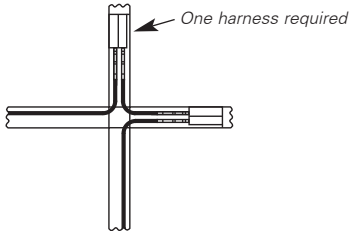

"X" or Cross Connection

To power a 4-way panel connection from one direction, specify at least two double block harnesses.

Duplex Receptacles

- 15 amp outlet configuration.
- Models HH871601 and HH871601A have a 20 amp outlet configuration.
- Fit back-to-back into the Power Block(s) of Power and Pass-Thru Harnesses.
- Labeled with the provided circuit. Circuits connected to the Isolated Ground are identified with an orange triangle; circuits that do not share a neutral or ground have an orange circuit number.

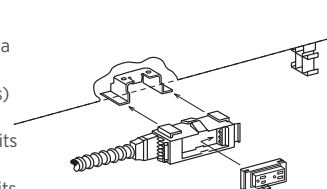

Power In-Feed (Base) Models HH879072 (72") and HH879168 (168")

- Used to connect the panel electrical system to the building electrical supply at a power block.
- Plugs into any receptacle position; can be rotated Left or Right.
- Conduit is UL listed Black Liquid-tight conduit (outside diameter is 7/8").

- ! A licensed electrician must make connections to a building electrical supply.
- ! Must be positioned through a receptacle opening in the baserail cover, prior to an electrician connecting to the power source.

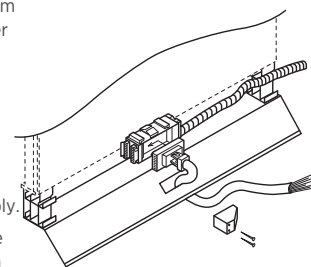

Power In-Feed Model (Ceiling) HH871912 and HH871918

- Used to connect the panel electrical system to the building electrical supply.
- ! A licensed electrician must make connections to a building electrical supply.
- ! Model uses UL recognized flex-cable conduit — no portion can be left exposed (i.e., must be in a power pole).
- ! Power Pole must be ordered separately.



HH871972

Note: In-feed cables listed above may be field-cut to desired length.

Electrical Jumper Cables

- ! When used to connect power between the base pathway and the beltline area, the jumper must be connected to a power block at one end of a run, routed into an adjacent panel that does not contain a power harness, then routed back into the panel containing a power harness or pass-thru cable and connected to a power harness in the other pathway.

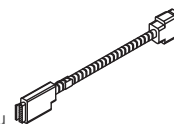

HH871366

Abound Electrical Mounting Brackets

- Use to mount ported receptacles at beltline.
- Screw into the panel frame.
- ! One mounting bracket required at beltline for each 24" W pass-thru or power harness. Two required for 30"-60" W power harness.

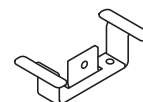

HH8988EBN

WORKING WITH CABLE MANAGEMENT

Base Pathway Receptacle Locations

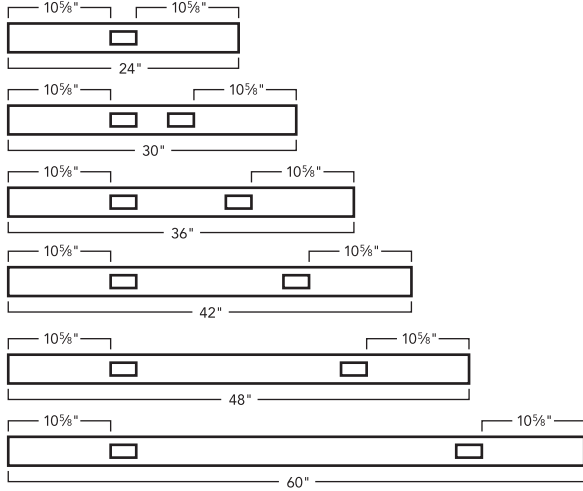

Abound® Lay-in Cable Capacity

The top and base pathway allow continuous voice and data lines to run through and between panels without interruption. Lay-in is provided for environments where systems furniture or cabling are subject to frequent change. All capacities are for Cat 6 cable with a 0.25" diameter.

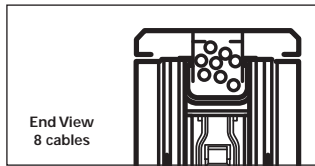

End View
8 cables
Top pathway accepts up to 8 voice/data cables (.25" dia.).

Abound® Cable Capacity

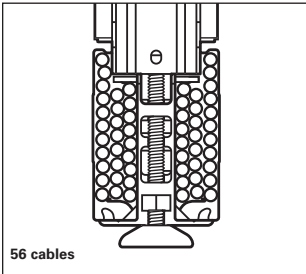

56 cables

Abound® base pathway accepts up to 56 voice/data cables (.25" dia.) (6.03 sq. in.) at 60% fill.

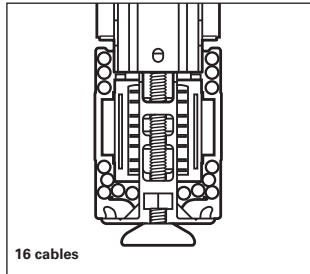

16 cables

When electrical system shares base pathway, the cable capacity in Abound is reduced to 16 cables (2.25 sq. in.). Cable quantities listed are at 60% fill ratio.

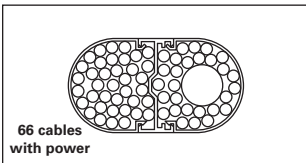

66 cables with power

Cable capacity of the power pole, in addition to electrical in-feed is 2.79 sq. in. on one side and 2.91 sq. in. on the other for a total capacity of 66 cables with power of .25" diameter.

Circuit Usage

Strategy 1

Circuits to Equipment

Assign specific uses for each of the circuits:

- For example, in a four-circuit system:
Circuit 1 – Calculators, fans, etc.
Circuit 2 – Task lights (could be wired to wall switch)
Circuit 3 – Computer monitors
Circuit 4 – CPUs

Strategy 2

Circuits to Workstations

Assign specific workstations to each of the three available circuits. Use circuit 4 for power-sensitive electronic equipment.

Placement of pedestals and lateral files may render some duplex locations inaccessible. Pedestal placement may also affect compatibility with pull-up receptacles.

Abound® Lay-In Cable Capacity

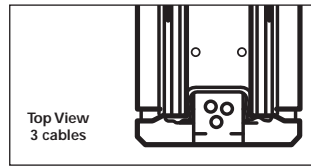

Top View
3 cables

Variable height junctions accept up to 3 voice/data cables (.25" dia.).

Accelerate® Cable Capacity

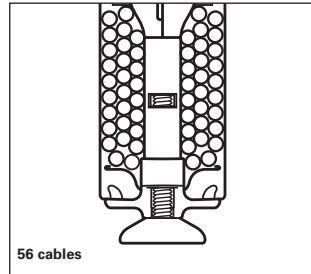

56 cables

Accelerate® base pathway accepts up to 56 voice/data cables (.25" dia.) (6.27 sq. in.) at 60% fill.

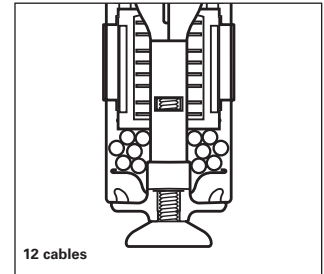

12 cables

When the electrical system shares the base pathway, the cable capacity in Accelerate® is reduced to 12 cables (.25" dia.) (2.03 sq. in.) at 60% fill ratio.

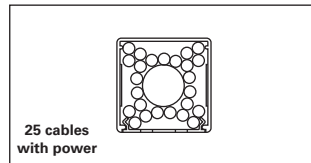

25 cables with power

Integrated Power Pole: 2" x 2" overall, 3.3"² interior accommodates a total of 25 cables with power of .25" diameter. Available in two heights: 6'6" or 13', the power pole connects via the universal connector and the overall height is the sum of the connector and the power pole. Constructed of aluminum with a powder coat paint finish in the specified color. Power pole requires a Ceiling In-Feed.

Ceiling In-Feeds: UL

listed as raceways. This means the electrical components are completely shielded and meet any requirements for separation of electrical components and communications cables per Section 800-52 of the National Electrical Code.



Icon Legend on page 19

SYSTEMS Electrical Components

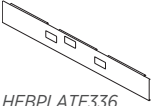
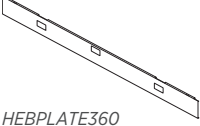
	DESCRIPTION	MODEL	SHIP WEIGHT	CUBE	LIST PRICE BY PAINT GRADE	
					P1	P2
 HEBPLATE336	Accelerate® Base Pathway Cover w/Additional Knockout					
	36"W	HEBPLATE336	7	0.4	\$72	\$82
	42"W	HEBPLATE342	8	0.4	\$74	\$84
	48"W	HEBPLATE348	9	0.4	\$77	\$87
	60"W	HEBPLATE360	11	0.5	\$88	\$98
	72"W	HEBPLATE372	14	0.6	\$98	\$108
	NOTES: Specify paint, see page 441. SPECIFYING EXAMPLE: HEBPLATE336.T4					
 HEBPLATE360	Abound® Base Pathway Cover w/Additional Knockout					
	36"W	HRVBPLATE336	7	0.4	\$72	\$82
	42"W	HRVBPLATE342	8	0.4	\$74	\$84
	48"W	HRVBPLATE348	9	0.4	\$77	\$87
	60"W	HRVBPLATE360	11	0.5	\$88	\$98
	NOTES: Specify paint, see page 391. SPECIFYING EXAMPLE: HRVBPLATE336.T4					

NOTES:

- Specify Pathways to match trim color.
- Standard raceways with two knockouts are standard on panels. If additional three knockout kickplate is ordered, the two port version can be saved or discarded.

HOW TO SPECIFY

<p>Select Model Number</p> <p>H E B P L A T E 3 3 6 .</p>	<p>Select Paint Color</p> <p>See page 441</p> <p>T 4</p>
---	--

SYSTEMS

Electrical Components

GSA SIN 33721



Icon Legend on page 19

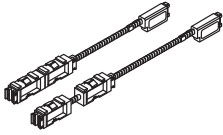

DESCRIPTION	MAX. RECEPT. CAP. PER PANEL SIDE	MODEL		SHIP WEIGHT	CUBE	LIST PRICE
		FOUR-CIRCUIT 3 + 1 2 + 2	THREE-CIRCUIT, SEPARATE NEUTRALS			
Electrical Power Harnesses, Frames — w/duplex capacity						
For 24"W	1	HH871224	HH871224A	2.0 Ⓢ	0.5	\$204
For 30"W	2	HH871230	HH871230A	2.0 Ⓢ	0.5	\$204
For 36"W	2	HH871236	HH871236A	2.5 Ⓢ	0.5	\$204
For 42"W	2	HH871242	HH871242A	3.0 Ⓢ	0.5	\$214
For 48"W	2	HH871248	HH871248A	3.0 Ⓢ	0.5	\$214
For 60"W	2	HH871260	HH871260A	3.0 Ⓢ	0.5	\$214
For 72"W (for use with Accelerate® 72"W panels only)	2	HH871272	HH871272A	5.0 Ⓢ	0.5	\$214

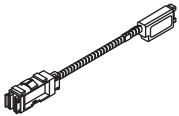

Electrical Pass-Thru Cables, Frames — w/duplex capacity						
For 24"W	1	HH871124	HH871124A	2.0 Ⓢ	0.5	\$128
For 30"W	1	HH871130	HH871130A	2.0 Ⓢ	0.5	\$128
For 36"W	1	HH871136	HH871136A	2.0 Ⓢ	0.5	\$128
For 42"W	1	HH871142	HH871142A	2.5 Ⓢ	0.5	\$134
For 48"W	1	HH871148	HH871148A	2.5 Ⓢ	0.5	\$134
For 60"W	1	HH871160	HH871160A	3.0 Ⓢ	0.5	\$134
For 72"W (for use with Accelerate® 72"W panels only)	1	HH871172	HH871172A	5.0 Ⓢ	0.5	\$134

NOTES: For use when data will be terminated in one cutout in the panel.

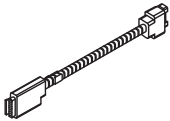

Electrical Pass-Thru Harness without Power Block						
For 24"W Frames	0	HH871024	HH871024A	2.0 Ⓢ	0.5	\$118
For 30"W Frames	0	HH871030	HH871030A	2.0 Ⓢ	0.5	\$118
For 36"W Frames	0	HH871036	HH871036A	2.0 Ⓢ	0.5	\$118
For 42"W Frames	0	HH871042	HH871042A	3.0 Ⓢ	0.5	\$123
For 48"W Frames	0	HH871048	HH871048A	3.0 Ⓢ	0.5	\$123
For 60"W Frames	0	HH871060	HH871060A	3.0 Ⓢ	0.5	\$123
For 72"W Frame Runs	0	HH871072		4.0 Ⓢ	0.5	\$170

NOTES:

- Duplex receptacles on page 561.
- Electric harnesses are intended for use with HON Systems furniture and are approved under GSA SIN 33721. When purchased separately and used without HON Systems furniture, the models are considered Open Market.



! Four-circuit components and three-circuit components (with "A" suffix) not designed to be used together. See pages 553-554.

HOW TO SPECIFY

Select Model Number	Select Color
HH871048 . P	See page 441

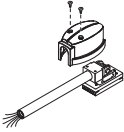
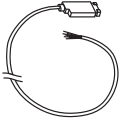
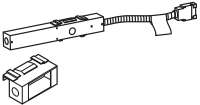

SYSTEMS Electrical Components

	DESCRIPTION	MODEL		SHIP WEIGHT	CUBE	LIST PRICE
		FOUR-CIRCUIT 3 + 1 2 + 2	THREE-CIRCUIT, SEPARATE NEUTRALS			
	Electrical Jumper Cables Jumper for up to 36" vertical jump, 66" long	HH871366	HH871366A	3.0 Ⓢ	0.5	\$138
	Power In-Feed Cables — Base In-Feed 72" long conduit, Sealtight Cable — 7/8" diameter	HH879072	HH879072A	4.5 Ⓢ	0.3	\$227
	168" long conduit, Sealtight Cable — 7/8" diameter	HH879168	HH879168A	9.0 Ⓢ	0.4	\$528
	Ceiling In-Feed 144" long conduit, Flex Cable — 7/8" dia.	HH871912	HH871912A	4.0 Ⓢ	0.5	\$235
	216" long conduit, Flex Cable — 7/8" dia.	HH871918	HH871918A	4.0 Ⓢ	0.5	\$307
	ⓘ Must be used with Power Pole. Power in-feed models HH871912 and HH871918 plug into the end of any power block. No portion of the cable can be exposed after installation.					
	Hardwire Applications					
	Hardwire Power In-feed	HH871400	HH871400A	4.0 Ⓢ	0.3	\$222
	ⓘ Customer to furnish all cabling and wiring from power entry to power source (approved for use by city of New York).					
 <i>Use when local codes require</i>	Hardwire Junction Box (6-pack)	HH871500		4.5 Ⓢ	0.1	\$472
	ⓘ For use with Accelerate® and Abound® Beltline only.					
	⚠ Hardwire Junction Boxes cannot be installed back-to-back in panel applications.					
	Hardwire Junction Box (6-pack)	HH873500		4.5 Ⓢ	0.2	\$441
	ⓘ For use with Abound® Raceway panels only.					
	NOTES: Junction Box can be positioned at any Duplex Receptacle location in 30"W or wider panels.					
	ⓘ Customer must furnish conduit, wiring and designer type receptacles. (Approved for use by city of Chicago.)					

NOTES:

- Duplex receptacles on page 561.
- ⓘ Four-circuit components and three-circuit components (with "A" suffix) not designed to be used together. See pages 553-554.
- ⓘ To connect power between the base pathway and the beltline area on Abound, four-circuit jumper cables (H8713xx) must be connected to a power block at one end of a run, routed into an adjacent panel that contains no power harness, then routed back into the panel that contains a power harness (or pass-thru cable), and connected to a power harness in the other pathway.

HOW TO SPECIFY

<p>Select Model Number</p> <p>HH871366 .</p>	<p>Select Color</p> <p>See page 441</p> <p>P</p>
--	--

SYSTEMS

Electrical Components

GSA SIN 33721



Icon Legend on page 19



DESCRIPTION

Abound® Integrated Power Pole
For 35"H-50"H Frames. Poles are 78"H.
For 65"H-95"H Frames. Poles are 52"H.

NOTES: Power Pole includes ceiling trim piece.

MODEL

SHIP WEIGHT

CUBE

LIST PRICE BY PAINT GRADE
P1

HEP35	9 Ⓢ	0.6	\$380
HEP65	6 Ⓢ	0.4	\$267



Power Pole Trim Kit (Abound® only)

24"W
30"W
36"W
42"W
48"W
60"W

HRVP24P
HRVP30P
HRVP36P
HRVP42P
HRVP48P
HRVP60P

2 Ⓢ
3 Ⓢ
4 Ⓢ
5 Ⓢ
6 Ⓢ
7 Ⓢ

0.3
0.4
0.5
0.5
0.6
0.7

\$133
\$141
\$148
\$151
\$155
\$164

DESCRIPTION

Power Pole — w/o Receptacles (Voi® only)
10'5"

• Used for routing In-Feed Cable from ceiling to panel baserail. Double cavity, plus conduit of In-Feed Cable serves as the division of electrical and communications cabling.

MODEL

SHIP WEIGHT

CUBE

LIST PRICE

HH870070	14	0.5	\$429
-----------------	----	-----	--------------



Specify paint color for HH870070, not available in Putty

DESCRIPTION

Accelerate® Integrated Power Pole
78"H x 2"W x 2"D
156"H x 2"W x 2"D

MODEL

SHIP WEIGHT

CUBE

LIST PRICE BY PAINT GRADE
P1 P2 P3

HECPP	14 Ⓢ	0.5	\$273	\$293	\$295
HECPP156	28 Ⓢ	1.0	\$662	\$682	\$684



DESCRIPTION

Receptacle Cover Replacements
Quantity 25

- ⚠ For use with Accelerate® panels only.
- ⚠ Specify Color — Available in Black (P), Muslin (T3) and Shadow (SHDW) only.

MODEL

SHIP WEIGHT

CUBE

LIST PRICE

HEREPCVR	1 Ⓢ	0.1	\$72
-----------------	-----	-----	-------------

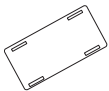

HOW TO SPECIFY

Select Model Number

Select Paint Color

See page 441

HRVP24P.

T4



Icon Legend on page 19

SYSTEMS Electrical Components



Each marked with
Circuit Number

DESCRIPTION

Abound® Duplex Receptacles

Circuit 1
Circuit 2
Circuit 3
Circuit 4

Circuit 1 — 20 amp outlet
Circuit 3 (2 + 2)

Specify color.

! Duplex receptacle models above are for use with Abound® models only.

DESCRIPTION	MODEL		SHIP WEIGHT	CUBE	LIST PRICE
	FOUR-CIRCUIT	THREE-CIRCUIT,			
	3 + 1 2 + 2	SEPARATE NEUTRALS			
Circuit 1	HH873501	HH873501A	0.5 Ⓞ	0.1	\$43
Circuit 2	HH873502	HH873502A	0.5 Ⓞ	0.1	\$43
Circuit 3	HH873503	HH873503A	0.5 Ⓞ	0.1	\$43
Circuit 4	HH873504		0.5 Ⓞ	0.1	\$43
Circuit 1 — 20 amp outlet	HH871601	HH871601A	1.0 Ⓞ	0.1	\$43
Circuit 3 (2 + 2)	HH873506		0.5 Ⓞ	0.1	\$43



Each marked with
Circuit Number

DESCRIPTION

Accelerate® Duplex Receptacles

Circuit 1
Circuit 2
Circuit 3 (except 2 + 2 — see below)
Circuit 4 — isolated, dedicated circuit

Circuit 1 (20 amp outlet configuration)
Circuit 3 (2 + 2)
Specify Paint.

NOTES: Use with Accelerate® models.

SPECIFYING EXAMPLE: HH871501.S

See page 441 for color options.

DESCRIPTION	MODEL		SHIP WEIGHT	CUBE	CORE LIST PRICE
	FOUR-CIRCUIT	THREE-CIRCUIT,			
	3 + 1 2 + 2	SEPARATE NEUTRALS			
Circuit 1	HH871501	HH871501A	1.0 Ⓞ	0.5	\$43
Circuit 2	HH871502	HH871502A	1.0 Ⓞ	0.5	\$43
Circuit 3 (except 2 + 2 — see below)	HH871503	HH871503A	1.0 Ⓞ	0.5	\$43
Circuit 4 — isolated, dedicated circuit	HH871504		1.0 Ⓞ	0.5	\$43
Circuit 1 (20 amp outlet configuration)	HH871601		1.0 Ⓞ	0.5	\$43
Circuit 3 (2 + 2)	HH871506		1.0 Ⓞ	0.5	\$43



DESCRIPTION

Data/Electrical Port Kit

Specify color

DESCRIPTION	MODEL		SHIP WEIGHT	CUBE	LIST PRICE
	FOUR-CIRCUIT	THREE-CIRCUIT,			
	3 + 1 2 + 2	SEPARATE NEUTRALS			
Data/Electrical Port Kit	HHT2DP		1.0 Ⓞ	0.1	\$24

NOTES:

• Data/Electrical Port Kit used for field installations of additional data accessories.

! Four-circuit components and three-circuit components (with "A" suffix) not designed to be used together. See pages 553-554.

Maximum Receptacle Capacity in Abound Panel Base Raceways

Widths	24	30	36	42	48	60
Maximum of 1 duplex per panel side	X					
Maximum of 2 duplexes per panel side	X	X	X	X	X	X

Duplex Color Recommended to Coordinate with Paint Color			
Paint Color	Paint Code	Duplex Color	Duplex Code
Black	P	Black	P
Brownstone	P7D	Brownstone	EY
Charcoal	S	Charcoal	S
Designer White	PJW	Designer White	DW
Fossil	P28	Charcoal	S
Greige	T5	Muslin	T3
Light Gray	Q	Loft	LOFT
Loft	LOFT	Loft	LOFT
Muslin	T3	Muslin	T3
Putty	L	Black	P
Shadow	SHDW	Muslin	T3
Silver	PR6	Titanium	TI
Titanium	P8T	Titanium	TI
Champagne Metallic	T4	Muslin	T3
Platinum Metallic	T1	Titanium	TI

Data / Electrical Port Kit Color Recommended to Coordinate with Paint Color			
Paint Color	Paint Code	Data / Port Kit Color	Data / Port Kit Code
Black	P	Black	P
Brownstone	P7D	Brownstone	EY
Charcoal	S	Charcoal	S
Designer White	PJW	Designer White	DW
Fossil	P28	Charcoal	S
Greige	T5	Muslin	T3
Light Gray	Q	Loft	LOFT
Loft	LOFT	Loft	LOFT
Muslin	T3	Muslin	T3
Putty	L	Black	P
Shadow	SHDW	Muslin	T2
Silver	PR6	Titanium	TI
Titanium	P8T	Titanium	TI
Champagne Metallic	T4	Muslin	T3
Platinum Metallic	T1	Titanium	TI

HOW TO SPECIFY

<p>Select Model Number</p> <p>HH873501 .</p>	<p>Select Color</p> <p>P</p> <p>See page 441</p>
--	--

SYSTEMS

Electrical Components

GSA SIN 33721 EXCEPT AS NOTED

ABI

Icon Legend on page 19

WORKSTATIONS

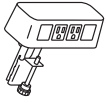

DESCRIPTION

Power & Data Center

2 Receptacles 2 Data Accessory

- Standard with two receptacles and openings for two data ports.
- 6' power cord with standard three-prong plug.
- Fits on any worksurface with a 4" overhang.
- UL Listed.

NOTES: Cable ports accommodate up to four individual voice and data outlets, and can be mounted anywhere there is an electrical receptacle opening. Data/Electrical Port Kit used for field installations of additional data accessories.

- ! Four-circuit components and three-circuit components (with "A" suffix) not designed to be used together. See pages 553-554.
- ! Duplex receptacle models shown on the previous page are for use with Abound® models only.
- ! Color finish coordinates with HON's Loft. *Specify LOFT when ordering. Example: HCOMDOME2.LOFT*

MODEL

HCOMDOME2

SHIP WEIGHT

2.5

CUBE

0.2

LIST PRICE

\$293

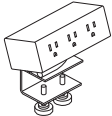

Model HPWRMOD3WC shown

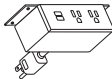

Model HPWRMOD2UWM shown

Power Modules

3 Receptacles with Worksurface Clamp

3 Receptacles with Under-Worksurface Mounting Bracket

2 Receptacles 2 USB with Worksurface Clamp

2 Receptacles 2 USB with Under-Worksurface Mounting Bracket

- 6' power cord with standard three-prong plug.
- Under-worksurface mounting bracket models work with any top that has a 5" x 5" square clearance.
- Worksurface clamp models work on any top with a 4" overhang.
- UL Listed.

NOTES: Cable ports accommodate up to four individual voice and data outlets, and can be mounted anywhere there is an electrical receptacle opening. Data/Electrical Port Kit used for field installations of additional data accessories.

- ! Four-circuit components and three-circuit components (with "A" suffix) not designed to be used together. See pages 553-554.
- ! Duplex receptacle models shown on the previous page are for use with Abound® models only.
- ! Color finish coordinates with HON's Charcoal or White. *Specify STRM for Storm and SNW for Snow when ordering. Example: HPWRMOD3WC.STRM*

HPWRMOD3WC

2.3

0.2

\$307

HPWRMOD3UWM

2.3

0.2

\$307

HPWRMOD2WC

2.3

0.2

\$491

HPWRMOD2UWM

2.3

0.2

\$491



Vertebrae

NOTES: 30"H x 3 1/8"W x 1 1/2"D. Ships unassembled.

- ! Clear finish. Specify "X" for finish option.
- SPECIFYING EXAMPLE: HMPVWM28.X**

HMPVWM28

3.0

0.3

\$221

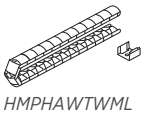

HMPHAWTWML



HMPHATFWML

Wire Managers for Height Adjustable

Workstation to Trough

Trough to Floor

- ! Wire Manager Workstation to Trough only available in black.

HMPHAWTWML

3.0

0.1

\$264

HMPHATFWML

2.0

0.3

\$249

OPEN MARKET

NOTES:

- For additional information see page 852.

HOW TO SPECIFY

Select Model Number

Select Color

See page 441

H C O M D O M E 2 .

L O F T

SYSTEMS

Electrical and Data

GSA SIN 33721 EXCEPT AS NOTED

ABI

Icon Legend on page 19

WORKSTATIONS

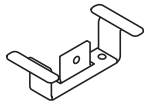

DESCRIPTION

MODEL

SHIP WEIGHT

CUBE

LIST PRICE

About Electrical Mounting Brackets (pack of 12)

HH8988EBN

3.0

0.1

\$63

1 bracket required at beltline for each pass-thru harness and 24"W power harness and 2 for 30"-60"W power harness.

Bracket for use at beltline only. Dimension of raceway mounting bracket is different and not interchangeable. Bracket height for beltline changed Q1 2019.

If adding onto product produced prior to Q1 2019, please contact HON Customer Support.

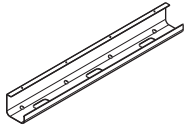

Cable Management Tray

24"
36"

HHCMT24

2.0

0.3

\$73

HHCMT36

3.0

0.4

\$90

Black only

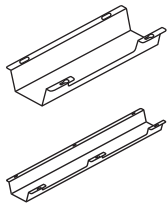

Cable Management Troughs

17"W — Single

HCTROUGH17

2.7

0.5

\$67

17"W — 10-Pack

HCTROUGH1710

14.0

0.5

\$620

36"W — Single

HCTROUGH36

4.9

0.9

\$113

36"W — 10-Pack

HCTROUGH3610

30.0

0.9

\$1045

• Cable management troughs ship flat packed.

• The troughs attach to underneath the worksurface with screws.

• The 17"W has one wire access cut out on the user side. The 36"W has two wire access cut outs. These cut outs give users access to inside the trough without having to detach it from the worksurface.

• Color: Graphite.

• Material: Metal.

• TAA Compliant.

• Slim profile design.

NOTES: For additional information see page 852.

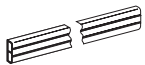

Wire Manager

• HHEM model clips to bottom of panels. (62"W)

HHEM620

10.0

0.5

\$103

• Slits in wire manager allows cable to be passed into unit.

Black only



HHTADF3

AMP Data Faceplates

Three-port flex-mode faceplate

HHTADF3

1.0

0.2

\$25

Four-port flex-mode faceplate

HHTADF4

1.0

0.2

\$25



HHTADF4

Data faceplates available in Black (E4) only.

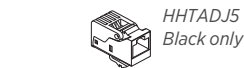

HHTADJ5

Black only

AMP RJ45 CAT 5E Jack — Black (P)

HHTADJ5

1.0

0.1

\$42

AMP RJ45 CAT 6 Jack — Black (P)

HHTADJ6

1.0

0.1

\$57

Models HHTADJ5 and HHTADJ6 snap into faceplate.

NOTES: AMP Data Faceplates attach to bottom of panel or at worksurface height in front of baserail covers for easy cable routing.

Faceplates cannot be installed back-to-back in a panel application.

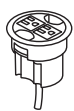

SIN 33721T

Power Hub, 3" Grommet Mount, 6' Cord

HGRMTAC

1.3

0.2

\$111

• Fits in 3" round grommet holes on the following product lines: Coordinate, Huddle, Motivate, all laminate and veneer casegoods series, and Systems Worksurfaces.

• Two grounded AC power outlets.

• Includes 6' cord with three-prong plug.

• Field installed with Plug-and-play ease.

NOTES: For additional information see page 848.

Available in black only (no color designation so use .X - Specify: HGRMTAC.X).

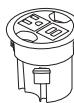

SIN 33721T

Power/USB Hub, 3" Grommet Mount

HGRMTUSB2

1.3

0.2

\$224

• One grounded AC power outlet with 2 USB ports.

• UL Listed.

NOTES: For additional information see page 848.

Available in black only (no color designation so use .X - Specify: HGRMTUSB2.X).

Working with Worksurfaces and Supports

Worksurfaces are 1½" thick with particle-board core and with top surfaces finished in high-pressure laminate. Bottom surfaces are covered with a backer sheet.

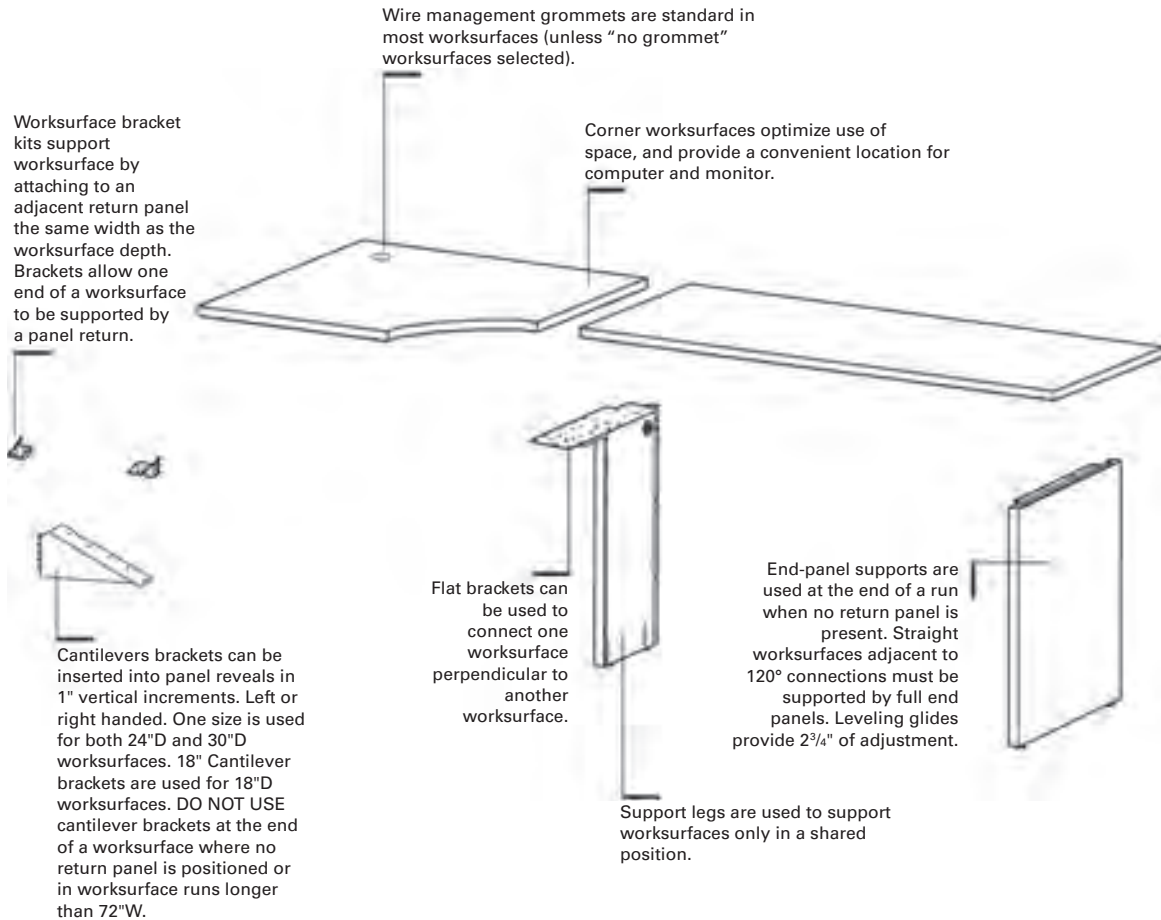

Primary worksurfaces are available in 18", 24" and 30" depths. Nominal worksurface width is equal to nominal panel width. Other support hardware is ordered separately.

Corner worksurfaces with woodgrain laminate have grain direction diagonal to adjacent worksurfaces. One rear center support bracket is included. All other support hardware is ordered separately.

Wire management grommets are standard in most worksurfaces. Worksurfaces less than 48"W have one grommet centered on edge of worksurface. Rectangular worksurfaces over 42"W have two grommets. Peninsulas have one grommet. Corner Worksurfaces have one grommet (one on each back edge). D-Shaped worksurfaces and countertops do not have grommets.

Edgeband is available on laminate tops in standard colors (customer specified) to match or complement solid, patterned, or woodgrain laminates.

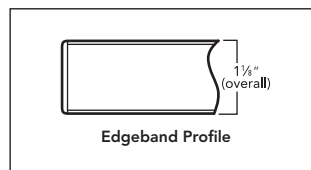

SYSTEMS

Working with Worksurfaces and Supports

Optional width worksurfaces are available for use with panel runs having a TEE or Extended Straight connection.

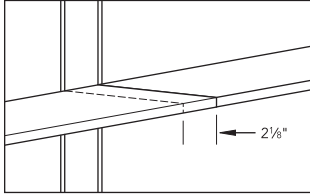

Worksurfaces can be configured at 29 1/2" with end-panel supports and support legs, or at various heights on 1" increments using specific product configurations.

Worksurface support options include:

- Open leg models
- Support column
- Flat brackets
- Worksurface bracket kit
- Cantilever bracket
- Universal support leg
- End-panel support
- Freestanding pedestal

Other worksurface supports include:

- Support columns
- External channel supports
- Support pedestals
- Pedestals with panel-to-pedestal bracket
- Desking freestanding shared leg

Support Guidelines:

- Unsupported panel runs greater than 72"W need floor support for improved stability.
- Worksurface bracket kit should be used to tie panels to worksurfaces for added stability.
- A panel run without a return needs a floor support.
- Unsupported worksurface spans of 60"W-84"W require an external worksurface support channel. It is recommended for 48"W-60"W.
- Cantilevers only to be used on worksurface runs 48"W or less.

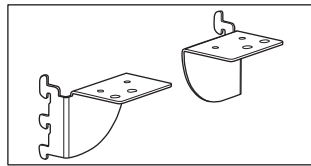

Worksurface bracket kit allows one end of a worksurface to be supported by a return panel. Return panel width must be the same as the depth of the worksurface.

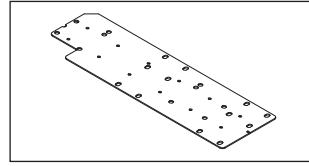

Flat brackets can be used to connect one worksurface perpendicular to another worksurface.

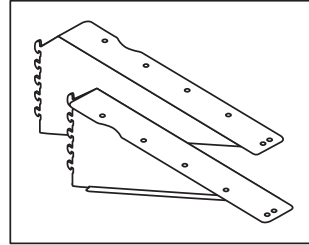

Cantilever brackets are left or right handed. They can be inserted into panel reveals in 1" vertical increments. One size is used for both 24" and 30"D worksurfaces. 18" Cantilever brackets are used for 18"D worksurfaces. Both left and right brackets are required in shared applications.

Important: Do not use cantilever brackets at the end of a worksurface where no 90° return panel is positioned.

- Do not use to support worksurfaces from which a hanging pedestal is suspended, or which a peninsula worksurface is attached.
- Do not use to support worksurfaces supported with permanent wall hanger kit.

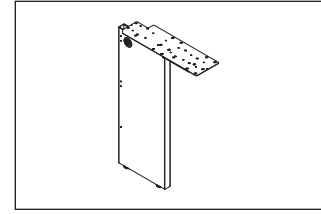

Universal support legs are used to support worksurfaces only in a shared position.

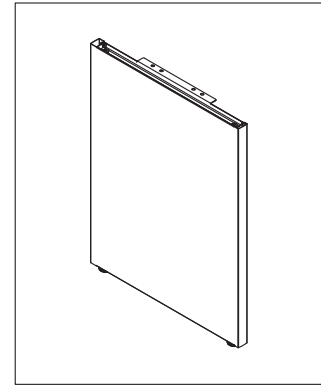

End-panel supports are used in place of return panels at the end of worksurface runs. Straight worksurfaces adjacent to 120° connections must be supported by full end panels. End-panel supports are ordered for right- or left-handed application. Leveling glides provide 1/2" of adjustment.

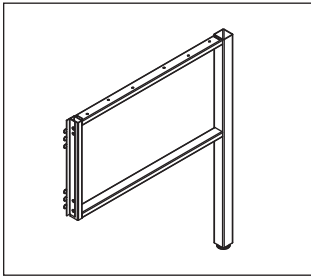

Open Leg models are used to support various worksurface configurations and include attaching hardware and leveling glides.

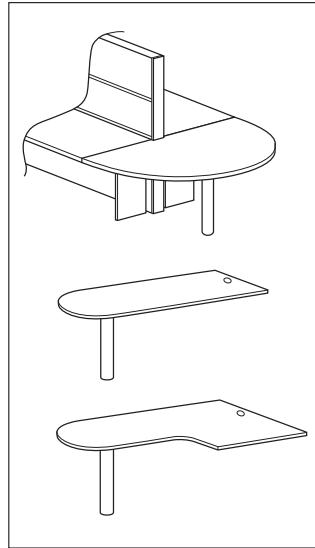

D-Shaped, Peninsula and Jetty worksurfaces require support columns (ordered separately).

Countertops are available in straight or corner configurations.

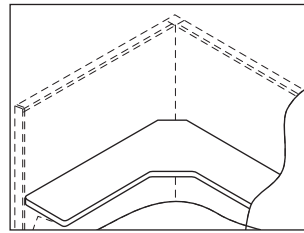

Corner shelves are available in Edgeband. Attachment brackets are included.

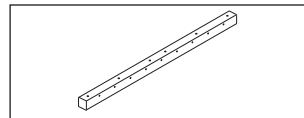

- Unsupported worksurface spans of 60"W-84"W require an external worksurface support channel. It is recommended for 48"W-60"W.

EXTERNAL CHANNEL SELECTION GUIDE

Support Combination		Rectangle Worksurface Width			
		Recommended		Required	
Worksurface End Support 1	Worksurface End Support 2	54	60	66	72
End Panel	End Panel	42"	48"	54"	60"
End Panel	Pedestal	NA	NA	NA	42"
End Panel	Worksurface Brackets	42"	48"	54"	60"
End Panel	Cantilever	42"	48"	54"	60"
End Panel	Open Leg	42"	48"	54"	60"
Pedestal	Pedestal	NA	NA	NA	NA
Pedestal	Worksurface Brackets	NA	NA	NA	42"
Pedestal	Cantilever	NA	NA	NA	42"
Pedestal	Open Leg	NA	NA	NA	42"
Worksurface Brackets	Worksurface Brackets	42"	48"	54"	60"
Worksurface Brackets	Cantilever	42"	48"	54"	60"
Worksurface Brackets	Open Leg	42"	48"	54"	60"

See page 187 for External Channel models.

Supports above are recommended for worksurfaces 54"W or 60"W. For 66"-72" worksurfaces, the supports are required.

SYSTEMS WORKSURFACES

Primary

GSA SIN 33721



Icon Legend on page 19

WORKSTATIONS

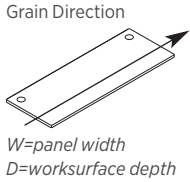

DESCRIPTION	MODEL	SHIP WEIGHT	CUBE	L1 LIST PRICE	L2 LIST PRICE
Primary and/or Return Worksurfaces					
24"W x 18"D	HWR1824P	23	2.1	\$299	\$309
30"W x 18"D	HWR1830P	28	2.1	\$309	\$319
36"W x 18"D	HWR1836P	35	2.5	\$321	\$331
42"W x 18"D	HWR1842P	39	2.8	\$333	\$343
48"W x 18"D	HWR1848P	44	3.2	\$368	\$378
54"W x 18"D	HWR1854P	48	4.0	\$408	\$423
60"W x 18"D	HWR1860P	53	4.0	\$420	\$435
66"W x 18"D	HWR1866P	65	4.7	\$450	\$465
72"W x 18"D	HWR1872P	67	4.7	\$462	\$477
24"W x 24"D	HWR2424P	31	2.2	\$305	\$315
30"W x 24"D	HWR2430P	37	2.2	\$320	\$330
36"W x 24"D	HWR2436P	46	2.5	\$346	\$361
42"W x 24"D	HWR2442P	52	2.5	\$380	\$395
48"W x 24"D	HWR2448P	58	3.3	\$404	\$419
54"W x 24"D	HWR2454P	64	4.0	\$429	\$449
60"W x 24"D	HWR2460P	70	4.0	\$477	\$497
66"W x 24"D	HWR2466P	86	4.8	\$512	\$532
72"W x 24"D	HWR2472P	89	4.8	\$529	\$549
84"W x 24"D	HWR2484P	103	5.1	\$750	\$775

NOTES:

- Worksurfaces may be used with Accelerate®, Abound® and Voi® products.
- Worksurfaces are constructed of laminate on 1½" solid core high-performance particleboard.
- Models up to 42"W are standard with one centered grommet. Models 48"W and wider are standard with two grommets.
- Accelerate® adds a "C" prefix and "T" suffix and Abound® adds a "B" prefix and "T" suffix to the Model Number for primary worksurfaces to span a TEE or EXTENDED STRAIGHT connection. Add upcharge of \$30 List per model.
- Add suffix "N" to Model Number for worksurfaces with no grommets. No upcharge.
- Woodgrain runs horizontally across surface.

- ! 18"D models are not available in Tee-Span but can be accommodated through Tailored Solutions.
- ! EXTENDED STRAIGHT worksurfaces are available with grommets only.
- ! 60"W, 66"W and 72"W worksurfaces require one or more of the following: worksurface support brackets, end panel, external channel universal support leg or pedestal support in conjunction with cantilever brackets.
- ! When a run of worksurfaces equals or exceeds 6 feet, a floor support is required for worksurface structural assurance.
- ! All worksurfaces load tested to BIFMA standards.

HOW TO SPECIFY

<p>Select Model Number</p> <p>For Tee-Span or Extended straight connection: Accelerate® adds a "C" prefix and "T" suffix (\$30 upcharge per model)</p> <p>Abound® adds a "B" prefix and "T" suffix (\$30 upcharge per model)</p> <p>No Grommet option: Add "N" suffix (no upcharge)</p> <p>HWR2424P .</p> <p>HCWR2424PT .</p> <p>HBWR2424PT .</p> <p>HWR2424PN .</p>	<p>Select Laminate</p> <p>See page 441</p> <p>A5 .</p> <p>A5 .</p> <p>A5 .</p> <p>A5 .</p>	<p>Select Edge Color</p> <p>See page 441</p> <p>K .</p> <p>K .</p> <p>K .</p> <p>K .</p>	<p>Select Grommet Color</p> <p>See page 441</p> <p>T1</p> <p>T1</p> <p>T1</p>
---	---	---	--



SYSTEMS WORKSURFACES

Primary

DESCRIPTION	MODEL	SHIP WEIGHT	CUBE	L1	L2
				LIST PRICE	LIST PRICE
Primary and/or Return Worksurfaces					
24"W x 30"D	HWR3024P	47	2.2	\$320	\$332
30"W x 30"D	HWR3030P	56	2.6	\$368	\$380
36"W x 30"D	HWR3036P	62	3.1	\$389	\$404
42"W x 30"D	HWR3042P	64	3.6	\$414	\$429
48"W x 30"D	HWR3048P	68	4.0	\$436	\$451
54"W x 30"D	HWR3054P	80	5.0	\$469	\$489
60"W x 30"D	HWR3060P	101	5.0	\$520	\$540
66"W x 30"D	HWR3066P	105	6.0	\$555	\$575
72"W x 30"D	HWR3072P	105	6.0	\$593	\$613
84"W x 30"D	HWR3084P	127	6.2	\$800	\$825

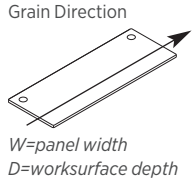

NOTES:

- Worksurfaces may be used with Accelerate®, Abound® and Voi® products.
- Worksurfaces are constructed of laminate on 1/8" solid core high-performance particleboard.
- Models up to 42"W are standard with one centered grommet. Models 48"W and wider are standard with two grommets.
- Accelerate® adds a "C" prefix and "T" suffix and Abound® adds a "B" prefix and "T" suffix to the Model Number for primary worksurfaces to span a TEE or EXTENDED STRAIGHT connection (adds 2 1/4" to width). Add upcharge of \$30 List per model.
- Add suffix "N" to Model Number for worksurfaces with no grommets. No upcharge.
- Woodgrain runs horizontally across surface.

- ! EXTENDED STRAIGHT worksurfaces are available with grommets only.
- ! 60"W, 66"W, 72"W, and 84"W worksurfaces require one or more of the following: worksurface support brackets, end panel, external channel universal support leg or pedestal support in conjunction with cantilever brackets.
- ! When a run of worksurfaces equals or exceeds 6 feet, a floor support is required for worksurface structural assurance.
- ! All worksurfaces load tested to BIFMA standards.

EXTERNAL CHANNEL SELECTION GUIDE						
Support Combination		Rectangle Worksurface Width				
Worksurface End Support 1	Worksurface End Support 2	54	60	66	72	84
End Panel	End Panel	42"	48"	54"	60"	72"
End Panel	Pedestal	NA	NA	NA	42"	48"
End Panel	Worksurface Brackets	42"	48"	54"	60"	72"
End Panel	Cantilever	42"	48"	54"	60"	72"
End Panel	Open Leg	42"	48"	54"	60"	72"
Pedestal	Pedestal	NA	NA	NA	NA	NA
Pedestal	Worksurface Brackets	NA	NA	NA	42"	48"
Pedestal	Cantilever	NA	NA	NA	42"	48"
Pedestal	Open Leg	NA	NA	NA	42"	48"
Worksurface Brackets	Worksurface Brackets	42"	48"	54"	60"	72"
Worksurface Brackets	Cantilever	42"	48"	54"	60"	72"
Worksurface Brackets	Open Leg	42"	48"	54"	60"	72"

See page 187 for External Channel models.

HOW TO SPECIFY

<p>Select Model Number</p> <p>For Tee-Span or Extended straight connection: Accelerate® adds a "C" prefix and "T" suffix (\$30 upcharge per model)</p> <p>Abound® adds a "B" prefix and "T" suffix (\$30 upcharge per model)</p> <p>No Grommet option: Add "N" suffix (no upcharge)</p> <p>HWR3024P .</p> <p>HCWR3024PT .</p> <p>HBWR3024PT .</p> <p>HWR3024PN .</p>	<p>Select Laminate</p> <p>See page 441</p> <p>A5 .</p> <p>A5 .</p> <p>A5 .</p> <p>A5 .</p>	<p>Select Edge Color</p> <p>See page 441</p> <p>K .</p> <p>K .</p> <p>K .</p> <p>K .</p>	<p>Select Grommet Color</p> <p>See page 441</p> <p>T1</p> <p>T1</p> <p>T1</p>
---	---	---	---

SYSTEMS WORKSURFACES

Wedge

GSA SIN 33721



Icon Legend on page 19

WORKSTATIONS

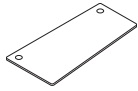
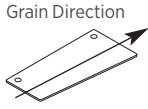

DESCRIPTION

Wedge Worksurfaces

48" A x 24" B x 30" C
 54" A x 24" B x 30" C
 60" A x 24" B x 30" C
 66" A x 24" B x 30" C
 72" A x 24" B x 30" C

MODEL

HWD244830P
HWD245430P
HWD246030P
HWD246630P
HWD247230P

SHIP WEIGHT

64
 80
 101
 105
 109

CUBE

4.8
 4.8
 4.8
 5.7
 5.7

L1 LIST PRICE

\$555
\$596
\$638
\$679
\$723

L2 LIST PRICE

\$570
\$616
\$658
\$699
\$743

Wedge Worksurfaces

48" A x 30" B x 24" C
 54" A x 30" B x 24" C
 60" A x 30" B x 24" C
 66" A x 30" B x 24" C
 72" A x 30" B x 24" C

HWD304824P
HWD305424P
HWD306024P
HWD306624P
HWD307224P

64
 80
 101
 105
 109

4.8
 4.8
 4.8
 5.7
 5.7

\$555
\$596
\$638
\$679
\$723

\$570
\$616
\$658
\$699
\$743

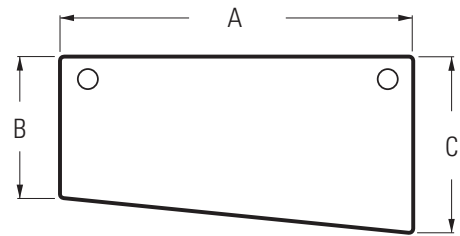
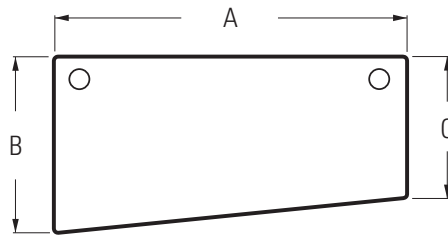

See matrix on page 569.

NOTES:

- Worksurfaces may be used with Accelerate®, Abound® and Voi® products.
 - Worksurfaces are constructed of laminate on 1½" solid core particleboard.
 - Refer to Worksurface Supports, pages 587-591.
 - Universal support leg can be used to share support when worksurfaces are placed side-by-side.
 - Add suffix "N" to Model Number for worksurfaces with no grommets. No upcharge.
 - Woodgrain runs horizontally across surface.
- ❗ 60"W, 66"W and 72"W worksurfaces require one or more of the following: worksurface support brackets, end panel, external channel universal support leg or pedestal support in conjunction with cantilever brackets. A full end panel can also be used for support in place of cantilever brackets.
- ❗ When a run of worksurfaces equals or exceeds 6 feet, a floor support is required for worksurface structural assurance.

HOW TO SPECIFY

<p>Select Model Number</p> <p>No Grommet option: Add "N" suffix (no upcharge)</p> <p>HWD244830P .</p> <p>HWD244830PN .</p>	<p>Select Laminate</p> <p>See page 441</p> <p>A5 .</p> <p>A5 .</p>	<p>Select Edge Color</p> <p>See page 441</p> <p>K .</p> <p>K .</p>	<p>Select Grommet Color</p> <p>See page 441</p> <p>T1</p>
---	---	---	--



SYSTEMS WORKSURFACES

Corner

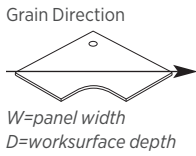

DESCRIPTION

Corner Worksurfaces with Curved User Edge

- 36"W x 24"D
- 42"W x 24"D
- 48"W x 24"D
- 42"W x 30"D
- 48"W x 30"D

MODEL

SHIP WEIGHT

CUBE

L1 LIST PRICE

L2 LIST PRICE

HWC3624P	53	3.7	\$542	\$557
HWC4224P	65	4.9	\$573	\$588
HWC4824P	76	6.3	\$644	\$659
HWC4230P	72	6.3	\$673	\$688
HWC4830P	77	6.3	\$725	\$740

- HWC3624P will not accept the H4022, H4028, or H4029 keyboard platforms.
- One small worksurface bracket standard with each worksurface.

! Corner worksurfaces must match exactly the panel behind them, i.e.: a 36" panel must be used on the back two sides of model HWC3624P.

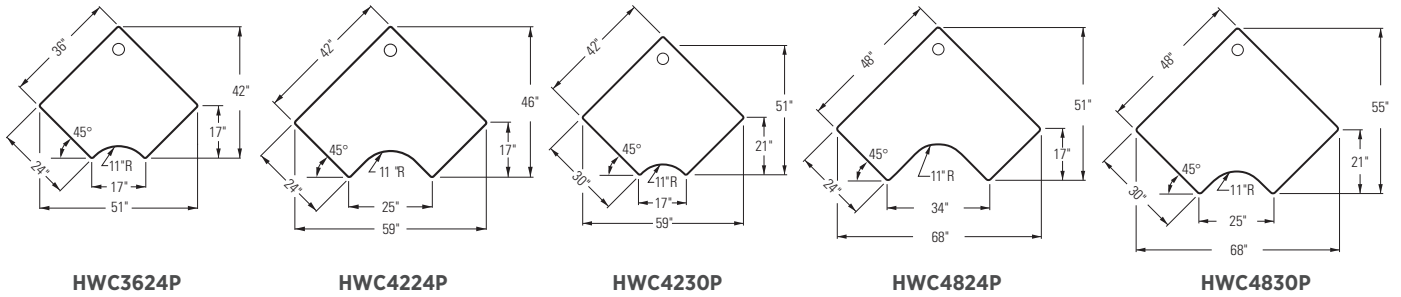

NOTES:

- Worksurfaces may be used with Accelerate®, Abound® and Voi® products.
- Add suffix **"N"** to Model Number for worksurfaces with no grommets. No upcharge.
- Worksurfaces are constructed of laminate on 1½" solid core high-performance particleboard.
- Refer to Worksurface Supports, pages 587-591.

HOW TO SPECIFY

<p>Select Model Number</p> <p>No Grommet option: Add "N" suffix (no upcharge)</p> <p>HWC3624P .</p> <p>HWC3624PN .</p>	<p>Select Laminate</p> <p>See page 441</p> <p>AS .</p> <p>AS .</p>	<p>Select Edge Color</p> <p>See page 441</p> <p>K .</p> <p>K .</p>	<p>Select Grommet Color</p> <p>See page 441</p> <p>T1</p>
--	---	---	--

SYSTEMS WORKSURFACES

Corner

GSA SIN 33721



Icon Legend on page 19

WORKSTATIONS

Grain Direction

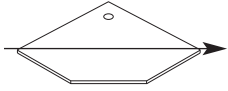

W=panel width

D=worksurface depth

DESCRIPTION

Corner Worksurfaces with Straight User Edge

36"W x 24"D

42"W x 24"D

48"W x 24"D

42"W x 30"D

48"W x 30"D

- HWCS3624P will not accept the H4022, H4028, or H4029 keyboard platforms.
- One small worksurface bracket standard with each worksurface.

❗ Corner worksurfaces must match exactly the panel behind them, i.e.: a 36" panel must be used on the back two sides of model HWCS3624P.

MODEL

HWCS3624P

HWCS4224P

HWCS4824P

HWCS4230P

HWCS4830P

SHIP WEIGHT

53

65

76

72

77

CUBE

3.7

4.9

6.3

6.3

6.3

L1 LIST PRICE

\$522

\$546

\$603

\$658

\$668

L2 LIST PRICE

\$537

\$561

\$618

\$673

\$683

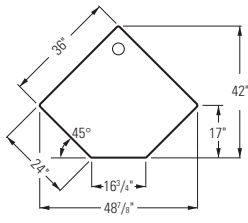

HWCS3624P

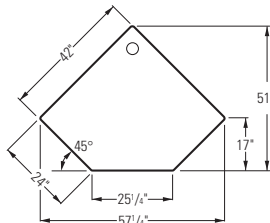

HWCS4224P

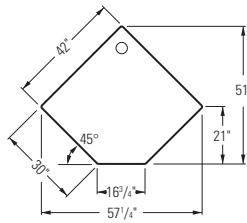

HWCS4230P

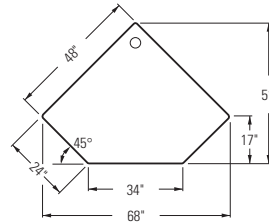

HWCS4824P

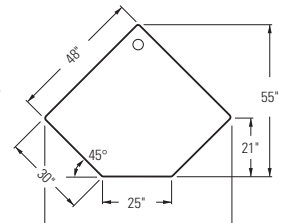

HWCS4830P

NOTES:

- Worksurfaces may be used with Accelerate®, Abound® and Voi® products.
- Add suffix "N" to Model Number for worksurfaces with no grommets. No upcharge.
- Worksurfaces are constructed of laminate on 1/8" solid core high-performance particleboard.
- Refer to Worksurface Supports, pages 587-591.

HOW TO SPECIFY

Select Model Number

No Grommet option: Add "N" suffix (no upcharge)

HWCS3624P .

HWCS3624PN .

Select Laminate

See page 441

AS .

AS .

Select Edge Color

See page 441

K .

K .

Select Grommet Color

See page 441

T1



SYSTEMS WORKSURFACES

120 Degree Corner

DESCRIPTION	MODEL	SHIP WEIGHT	CUBE	L1	L2
				LIST PRICE	LIST PRICE
Abound® and Accelerate® 120 Degree Corner Worksurfaces with Curved User Edge 36"W x 24"D 42"W x 24"D 48"W x 24"D 42"W x 30"D 48"W x 30"D W=panel width D=worksurface depth	HBWCT3624P	75	7.7	\$777	\$792
	HBWCT4224P	96	9.2	\$833	\$848
	HBWCT4824P	107	9.2	\$965	\$980
	HBWCT4230P	102	11.4	\$1094	\$1109
	HBWCT4830P	112	11.4	\$1164	\$1179

- HBWCT3624P will not accept the H4022, HE4022, H4028, or H4029 keyboard platforms.
 - One small worksurface bracket standard with each worksurface.
- ❗ Corner worksurfaces must match exactly the panel behind them, i.e.: a 36" panel must be used on the back two sides of model HBWCT3624P.

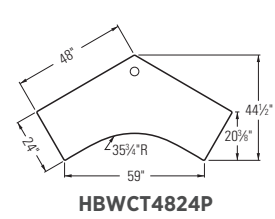
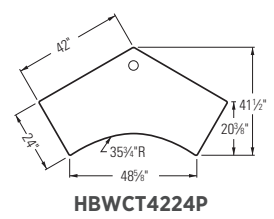
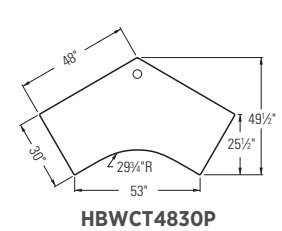
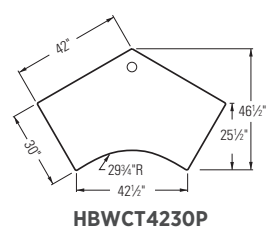
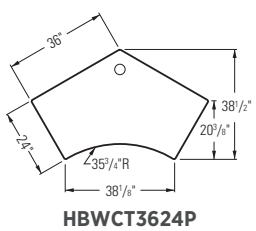
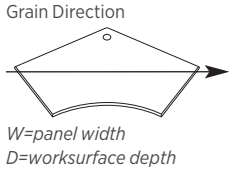

- NOTES:**
- Worksurfaces are constructed of laminate on 1/8" solid core high-performance particleboard.
 - Add suffix "N" to Model Number for worksurfaces with no grommets. No upcharge.
 - Refer to Worksurface Supports, pages 587-591.
 - If used at an end of run, full end panel needs to be ordered — see page 587.

HOW TO SPECIFY

<p>Select Model Number</p> <p>No Grommet option: Add "N" suffix (no upcharge)</p> <p>HBWCT3624P .</p> <p>HBWCT3624PN .</p>	<p>Select Laminate</p> <p>See page 441</p> <p>AS .</p> <p>AS .</p>	<p>Select Edge Color</p> <p>See page 441</p> <p>K .</p> <p>K .</p>	<p>Select Grommet Color</p> <p>See page 441</p> <p>T1</p>
---	---	---	--

SYSTEMS WORKSURFACES

Corner Cove

GSA SIN 33721



Icon Legend on page 19

Grain Direction

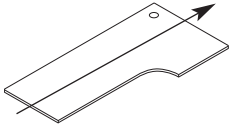

DESCRIPTION

Corner Cove Worksurfaces, Left Hand

60" A x 36" B x 24" C x 24" D
60" A x 36" B x 30" C x 24" D

60" A x 48" B x 24" C x 24" D
60" A x 48" B x 24" C x 30" D
60" A x 48" B x 30" C x 24" D
60" A x 48" B x 30" C x 30" D

72" A x 36" B x 24" C x 24" D
72" A x 36" B x 30" C x 24" D

72" A x 48" B x 24" C x 24" D
72" A x 48" B x 24" C x 30" D
72" A x 48" B x 30" C x 24" D
72" A x 48" B x 30" C x 30" D

MODEL

HWV73AALP
HWV73BALP

HWV75AALP
HWV75ABLP
HWV75BALP
HWV75BBLP

HWV93AALP
HWV93BALP

HWV95AALP
HWV95ABLP
HWV95BALP
HWV95BBLP

SHIP WEIGHT

67
76

85
94
92
99

75
83

96
107
102
112

CUBE

5.9
5.9

7.7
7.7
7.7
7.7

7.0
7.0

9.2
9.2
9.2
9.2

L1 LIST PRICE

\$609
\$631

\$668
\$691
\$691
\$716

\$668
\$691

\$834
\$857
\$857
\$884

L2 LIST PRICE

\$634
\$656

\$698
\$721
\$721
\$746

\$698
\$721

\$869
\$892
\$892
\$919

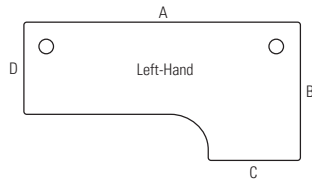

NOTES:

- Worksurfaces may be used with Accelerate®, Abound® and Voi® products.
- Worksurfaces are constructed of laminate on 1/8" solid core high-performance particleboard.
- Includes a rear-support bracket in Charcoal only.
- Add suffix **"N"** to Model Number for worksurfaces with no grommets. No upcharge.
- Refer to Worksurface Supports, pages 587-591.

! Panel-hung application requires two panels of corresponding width joined at 90°.

! When a run of worksurfaces equals or exceeds 6 feet, a floor support is required for worksurface structural assurance.

! 60"W, 66"W and 72"W worksurfaces require one or more of the following: worksurface support brackets, end panel, external channel universal support leg or pedestal support in conjunction with cantilever brackets.

HOW TO SPECIFY

Select Model Number

No Grommet option: Add **"N"** suffix (no upcharge)

HWV73AALP

HWV73AALPN

Select Laminate

See page 441

AS

AS

Select Edge Color

See page 441

K

K

Select Grommet Color

See page 441

T1



SYSTEMS WORKSURFACES

Corner Cove

DESCRIPTION	MODEL	SHIP WEIGHT	CUBE	L1	L2
				LIST PRICE	LIST PRICE
Corner Cove Worksurfaces, Right Hand 60" A x 36" B x 24" C x 24" D 60" A x 36" B x 30" C x 24" D	HWV73AARP	67	5.9	\$609	\$634
	HWV73BARP	76	5.9	\$631	\$656
60" A x 48" B x 24" C x 24" D 60" A x 48" B x 24" C x 30" D 60" A x 48" B x 30" C x 24" D 60" A x 48" B x 30" C x 30" D	HWV75AARP	85	7.7	\$668	\$698
	HWV75ABRP	94	7.7	\$691	\$721
	HWV75BARP	92	7.7	\$691	\$721
	HWV75BBRP	99	7.7	\$716	\$746
	HWV93AARP	75	7.0	\$668	\$698
HWV93BARP	83	7.0	\$691	\$721	
72" A x 48" B x 24" C x 24" D 72" A x 48" B x 24" C x 30" D 72" A x 48" B x 30" C x 24" D 72" A x 48" B x 30" C x 30" D	HWV95AARP	96	9.2	\$834	\$869
	HWV95ABRP	107	9.2	\$857	\$892
	HWV95BARP	102	9.2	\$857	\$892
	HWV95BBRP	112	9.2	\$884	\$919

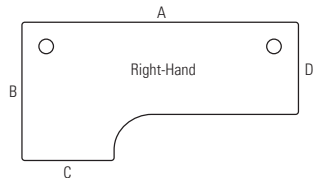
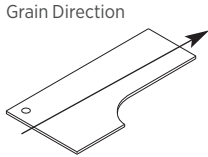

NOTES:

- Worksurfaces may be used with Accelerate®, Abound® and Voi® products.
- Worksurfaces are constructed of laminate on 1/8" solid core high-performance particleboard.
- Includes a rear-support bracket in Charcoal only.
- Add suffix **"N"** to Model Number for worksurfaces with no grommets. No upcharge.
- Refer to Worksurface Supports, pages 587-591.
- ❗ Panel-hung application requires two panels of corresponding width joined at 90°.
- ❗ When a run of worksurfaces equals or exceeds 6 feet, a floor support is required for worksurface structural assurance.
- ❗ 60"W, 66"W and 72"W worksurfaces require one or more of the following: worksurface support brackets, end panel, external channel universal support leg or pedestal support in conjunction with cantilever brackets.

HOW TO SPECIFY

<p>Select Model Number</p> <p>No Grommet option: Add "N" suffix (no upcharge)</p> <p>HWV73AARP .</p> <p>HWV73AARP N .</p>	<p>Select Laminate</p> <p>See page 441</p> <p>AS .</p> <p>AS .</p>	<p>Select Edge Color</p> <p>See page 441</p> <p>K .</p> <p>K .</p>	<p>Select Grommet Color</p> <p>See page 441</p> <p>T1</p>
---	---	---	--

SYSTEMS WORKSURFACES

Jetty / Peninsula

GSA SIN 33721



Icon Legend on page 19

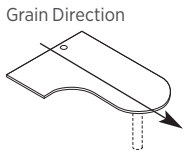

DESCRIPTION

Jetty Worksurfaces, Left Hand

- 48" A x 66" B x 24" C x 30" D
- 48" A x 66" B x 30" C x 30" D
- 48" A x 72" B x 24" C x 30" D
- 48" A x 72" B x 30" C x 30" D

! Requires support column — see page 589. Order support column separately.

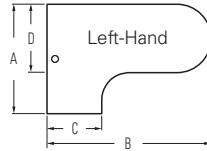

MODEL

SHIP WEIGHT

CUBE

L1 LIST PRICE

L2 LIST PRICE

HWJ58ABLP	84	9.2	\$838	\$868
HWJ58BBLP	91	9.2	\$839	\$869
HWJ59ABLP	88	9.2	\$843	\$873
HWJ59BBLP	94	9.2	\$840	\$870

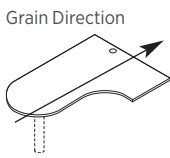

Jetty Worksurfaces, Right Hand

- 48" A x 66" B x 24" C x 30" D
- 48" A x 66" B x 30" C x 30" D
- 48" A x 72" B x 24" C x 30" D
- 48" A x 72" B x 30" C x 30" D

! Requires support column — see page 589. Order support column separately.

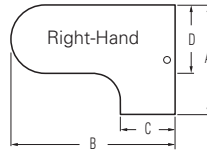

HWJ58ABRP	84	9.2	\$838	\$868
HWJ58BRRP	91	9.2	\$839	\$869
HWJ59ABRP	88	9.2	\$843	\$873
HWJ59BRRP	94	9.2	\$840	\$870

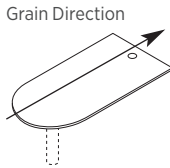

Peninsula Worksurfaces

- 60" W x 24" D
- 66" W x 24" D
- 72" W x 24" D
- 60" W x 30" D
- 66" W x 30" D
- 72" W x 30" D

! Peninsula worksurface width must correspond to the width of its support panel. Requires support column — see page 589. Order support column separately.

HWP2460P	65	4.9	\$393	\$413
HWP2466P	72	4.6	\$479	\$499
HWP2472P	95	5.5	\$540	\$560
HWP3060P	68	5.0	\$629	\$649
HWP3066P	75	6.0	\$690	\$710
HWP3072P	98	6.0	\$760	\$780

NOTES:

- Worksurfaces may be used with Accelerate®, Abound® and Voi® products.
- Worksurfaces are constructed of laminate on 1½" solid core high-performance particleboard.
- Order support column separately — see page 589.
- Can also be attached perpendicular to a primary worksurface using Flat Brackets. Do not attach to a worksurface supported with Cantilever Brackets.
- Add suffix "N" to Model Number for worksurfaces with no grommets. No upcharge.
- Refer to Worksurface Supports, pages 587-591.
- ! Not designed to be used freestanding.

HOW TO SPECIFY

<p>Select Model Number</p> <p>No Grommet option: Add "N" suffix (no upcharge)</p> <p>HWJ58ABLP .</p> <p>HWJ58ABLPN .</p>	<p>Select Laminate</p> <p>See page 441</p> <p>AS .</p> <p>AS .</p>	<p>Select Edge Color</p> <p>See page 441</p> <p>K .</p> <p>K .</p>	<p>Select Grommet Color</p> <p>See page 441</p> <p>T1</p>
---	---	---	--



Icon Legend on page 19

SYSTEMS WORKSURFACES

Half-Round / Quarter Round / 60° Wedge

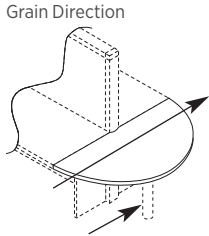

Requires Support Column — see page 589.

DESCRIPTION

Abound® Half-Round Worksurfaces

50"W x 30"D Connects to two 24"D Worksurfaces
62"W x 36"D Connects to two 30"D Worksurfaces

MODEL

HBWD2450P
HBWD3062P

SHIP WEIGHT

52
58

CUBE

5.0
6.1

L1 LIST PRICE

\$621
\$723

L2 LIST PRICE

\$636
\$743

Accelerate® Half-Round Worksurfaces

50"W x 30"D Connects to two 24"D Worksurfaces
62"W x 36"D Connects to two 30"D Worksurfaces

HCWD2450P
HCWD3062P

52
58

5.0
6.1

\$621
\$723

\$636
\$743

NOTES: Order one Support Column and two Universal Support Legs or Full End Panel — see pages 587-589.

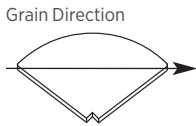
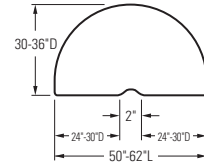

Abound® Quarter-Round Worksurfaces

24"W x 24"W Connects to two 24"D Worksurfaces
30"W x 30"W Connects to two 30"D Worksurfaces

HBWQ2424P
HBWQ3030P

18
25

2.6
3.7

\$356
\$447

\$371
\$467

Accelerate® Quarter-Round Worksurfaces

24"W x 24"W Connects to two 24"D Worksurfaces
30"W x 30"W Connects to two 30"D Worksurfaces

HCWQ2424P
HCWQ3030P

18
25

2.6
3.7

\$356
\$447

\$371
\$467

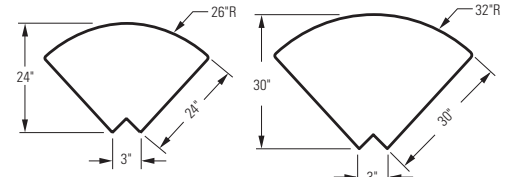

HBWQ2424P
HCWQ2424P

HBWQ3030P
HCWQ3030P

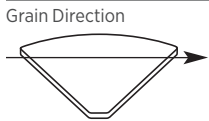

Abound® 60° Wedge Worksurfaces for use with 120 degree Universal Connector

24"W x 24"W Abound® Only
30"W x 30"W Abound® Only

HBWQT2424P
HBWQT3030P

18
25

2.6
3.7

\$395
\$459

\$410
\$479

Accelerate® 60° Wedge Worksurfaces for use with 120 degree Universal Connector

24"W x 24"W Accelerate® Only
30"W x 30"W Accelerate® Only

HCWQT2424P
HCWQT3030P

17
25

2.4
2.9

\$393
\$456

\$408
\$476

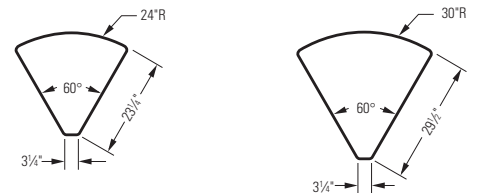

HBWQT2424P
HCWQT2424P

HBWQT3030P
HCWQT3030P

NOTES:

- Worksurfaces are constructed of laminate on 1/8" solid core high-performance particleboard.

Half-Round Worksurfaces

- Order Support Column and End Panels separately.

Quarter Round Worksurfaces

- Two Flat Brackets and one Tie Bracket included.

60° Wedge Worksurfaces

- Two flat brackets and one tie bracket included.
- Refer to Worksurface Supports, pages 587-591.

HOW TO SPECIFY

Select Model Number	Select Laminate	Select Edge Color
HBWD2450P	A5	K
HCWD2450P	A5	K

SYSTEMS COUNTERTOPS

Straight and Corner

GSA SIN 33721



Icon Legend on page 19

WORKSTATIONS

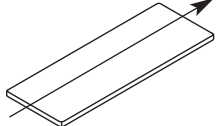
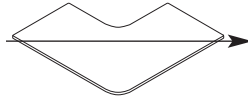
	DESCRIPTION	MODEL	SHIP WEIGHT	CUBE	L1 LIST PRICE	L2 LIST PRICE
Grain Direction 	Abound® and Accelerate® 15"D Straight Countertops					
	24"W x 15"D	HBCSR1524P	19	1.4	\$222	\$232
	30"W x 15"D	HBCSR1530P	25	1.4	\$245	\$255
	36"W x 15"D	HBCSR1536P	27	1.6	\$274	\$284
	42"W x 15"D	HBCSR1542P	32	1.8	\$282	\$292
	48"W x 15"D	HBCSR1548P	38	2.1	\$298	\$308
	60"W x 15"D	HBCSR1560P	48	2.6	\$378	\$393
	66"W x 15"D	HBCSR1566P	53	2.7	\$391	\$406
72"W x 15"D	HBCSR1572P	59	3.1	\$405	\$420	
Grain Direction 	Abound® and Accelerate® 15"D Corner Countertops					
	24"W x 24"D	HBCSR2424P	44	1.4	\$424	\$439
	30"W x 30"D	HBCSR3030P	51	1.4	\$494	\$509
	36"W x 36"D	HBCSR3636P	58	1.6	\$549	\$569

NOTES:

- Countertops constructed with high-pressure laminate.
- Specify laminate and Edgeband options color.

HOW TO SPECIFY

<p>Select Model Number</p> <p>H B C S R 1 5 2 4 P .</p>	<p>Select Laminate</p> <p>See page 441</p> <p>A 5 .</p>	<p>Select Edge Color</p> <p>See page 441</p> <p>K</p>
--	--	--



SYSTEMS COUNTERTOPS

Straight and Corner

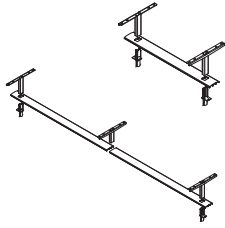

DESCRIPTION

Abound® Raised Straight Countertop Kits

	MODEL	SHIP WEIGHT	CUBE	LIST PRICE BY PAINT GRADE	
				P1	P2
24"W	HRVBR1524	5	1.0	\$133	\$150
30"W	HRVBR1530	5	1.0	\$140	\$157
36"W	HRVBR1536	6	2.0	\$148	\$165
42"W	HRVBR1542	6	2.0	\$153	\$170
48"W	HRVBR1548	7	2.0	\$159	\$176
60"W	HRVBR1560	8	2.0	\$189	\$206
66"W	HRVBR1566	8	3.0	\$202	\$219
72"W	HRVBR1572	9	3.0	\$217	\$234

! Do not order top caps for the panels the Countertop Kits will be installed on. Countertop Kits come with the necessary top caps and hardware.

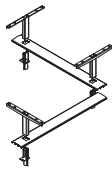

Abound® Raised Corner Countertop Kits

24"W	HRVBR1524P	5	1.0	\$167	\$184
30"W	HRVBR1530P	6	1.0	\$175	\$192
36"W	HRVBR1536P	6	2.0	\$183	\$200

! Do not order top caps for the panels the Countertop Kits will be installed on. Countertop Kits come with the necessary top caps and hardware.

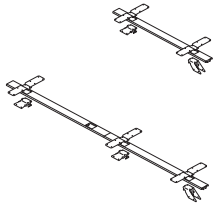

Abound® Straight Countertop Kits

24"W	HBCKIT24	5	0.7	\$50	N/A
30"W	HBCKIT30	5	0.9	\$52	N/A
36"W	HBCKIT36	6	0.9	\$54	N/A
42"W	HBCKIT42	6	1.2	\$56	N/A
48"W	HBCKIT48	7	1.4	\$58	N/A
60"W	HBCKIT60	8	1.8	\$61	N/A
66"W	HBCKIT66	8	1.8	\$63	N/A
72"W	HBCKIT72	9	1.9	\$65	N/A

! Straight Countertop Kits must match the width of the corresponding panel onto which they are installed.

! 66"W kit must be used with 30" and 36"W frames.

! 72"W kit must be used with two 36"W frames.

! Do not order top caps for the panels onto which the Countertop Kits are installed. Countertop Kits come with the necessary top caps and hardware.

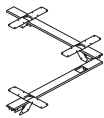

Abound® Corner Countertop Kits

24"W	HBCKKIT24	5	0.7	\$60	N/A
30"W	HBCKKIT30	6	1.0	\$67	N/A
36"W	HBCKKIT36	6	1.0	\$69	N/A

! Do not order top caps for the panels the Countertop Kits will be installed on. Countertop Kits come with the necessary top caps and hardware.

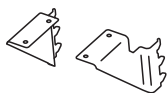

Accelerate® Countertop Bracket Kit

	HECB01	1	0.1	\$51	\$54
--	--------	---	-----	------	------

! For use with all panel heights, except 42½".

! Top caps required and specified separately from Accelerate® Countertop Bracket Kits.

Accelerate® Countertop Bracket Kit for 42½"H Panels

	HECB42	1	0.1	\$51	\$54
--	--------	---	-----	------	------

! For use with 42½"H Panels only.

! Top caps required and specified separately from Accelerate® Countertop Bracket Kits.

! Bracket kits include one right and one left hand bracket. Order two sets of brackets for the straight countertop models and three sets for the corner countertop models. To be used on Accelerate® panels only.

SPECIFYING EXAMPLE: HECB01.LOFT

HOW TO SPECIFY

<p>Select Model Number</p> <p>HRVBR1524</p>	<p>Select Paint Color</p> <p>See page 441</p> <p>A5</p>
---	---

SYSTEMS SHELVES

Corner Shelves

GSA SIN 33721 EXCEPT AS NOTED



Icon Legend on page 19

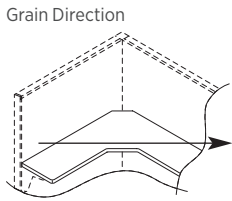

DESCRIPTION

Corner Shelves
36" x 36" x 12"D
42" x 42" x 12"D

MODEL	SHIP WEIGHT	CUBE	L1 LIST PRICE	L2 LIST PRICE
HCS3636P	33	3.6	\$403	\$423
HCS4242P	33	3.6	\$422	\$447

NOTES:

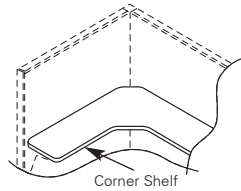

- Corner Shelves may be used with both Abound® and Accelerate® systems products.
- Diagonal leading edge = 10½"
- Diagonal depth = 22½"
- Includes panel attachment brackets.

HOW TO SPECIFY

Select Model Number	Select Laminate	Select Edge Color	Select Paint Color
See page 441	See page 441	See page 441	See page 441
HCS3636P	A5	K	T1

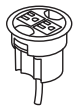

SIN 33721T

DESCRIPTION

Power Hub, 3" Grommet Mount, 6' Cord

- Fits in 3" round grommet holes on the following product lines: 10500, 10700, Coordinate and Voi desks; Systems Worksurfaces; Huddle and Motivate tables and SmartLink.
- Two grounded AC power outlets.
- Includes 6' cord with three-prong plug.
- Field installed with Plug-and-play ease.

NOTES: For additional information see page 848.

Available in black only (no color designation so use .X - Specify: HGRMTAC.X).

MODEL	SHIP WEIGHT	CUBE	LIST PRICE BY PAINT GRADE
			P1
HGRMTAC	1.3	0.2	\$111



COORDINATE™ Height Adjustable Bases

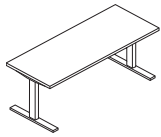

Base shown with work surface attached.

DESCRIPTION

Height Adjustable Base – 2 Stage
24”D Feet and Worksurface Brackets

MODEL SHIP WEIGHT CUBE LIST PRICE

HHAB2S2L 63 2.4 \$1006

NOTES: Base is a dual motor 2-stage design. Legs raise from 25⁵/₈” to 45¹/₄”. Base telescopes to accommodate any rectangular work surface between 24”D x 42”W and 30”D x 72”W. Supports weight capacity of 250 lbs. (excluding work surface weight). See page 583 for Voi® Worksurfaces. See page 583 for Systems Worksurfaces. For Height Adjustable Base Accessories see page 583. Foundation™, Systems, Voi®, 10500, and Preside® all have worksurfaces within this range.

⚠ When attaching a Keyboard Tray, remember to also specify a Keyboard Spacer Kit (HKBS).

⚠ Telescoping horizontal frame will extend just over 2” from underside of the work surface.

SPECIFYING EXAMPLE: HHAB2S2L.P8L

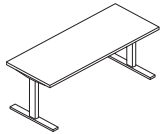

Base shown with work surface attached.

Height Adjustable Base – 3 Stage
24”D Feet and Worksurface Brackets

HHAB3S2L 67 2.4 \$1120

NOTES: Base is a dual motor 3-stage design. Legs raise from 21⁵/₈” to 47³/₄”. Base telescopes to accommodate any rectangular work surface between 24”D x 42”W and 30”D x 72”W. Supports weight capacity of 250 lbs. (excluding work surface weight). Foundation™, Systems, Voi®, 10500, and Preside® all have worksurfaces within this range.

⚠ Telescoping horizontal frame will extend just over 2” from underside of the work surface.

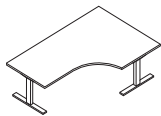

Base shown with work surface attached.

3-Leg Height Adjustable Base – 3 Stage
24”D Feet and Worksurface Brackets

HHAB3S3L 91 3.6 \$1896

NOTES: Base is a three motor 3-stage design. Legs raise from 21⁵/₈” to 47³/₄”. **The 3-leg base supports corner covers or two-piece worksurfaces 41”-72”W x 35”-72”L x 23³/₄”-30”D. 48”W 120 degree corner worksurfaces are also supported. When using two worksurfaces, the connection between the two must be over the telescoping frame. Supports weight capacity of 375 lbs. (excluding work surface weight).** Can be used with 48” 120 degree and work surface models.

⚠ When using two worksurfaces, a flat bracket is required. Bracket purchased separately — HHN831124, HHN831130 — see page 582.

⚠ 120 degree and corner worksurfaces are not reduced in size to provide clearance between panels.

⚠ Telescoping horizontal frame will extend just over 2” from underside of the work surface.

NOTES:

- Comes standard with one-touch, four memory controller with digital display; no specification needed, available in black finish only.
- **HON 5-Year Limited Warranty.**

⚠ Coordinate™ Height Adjustable Bases not compatible with 36”D rectangular worksurfaces.

HOW TO SPECIFY

<p>Select Model Number</p> <p>HHAB2S2L .</p>	<p>Select Finish</p> <p>P71 Black P8L Nickel PD8 White</p> <p>P8L</p>
---	--

COORDINATE™ Accessories

GSA SIN AS NOTED



Icon Legend on page 19

WORKSTATIONS

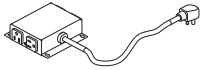

SIN 33721

DESCRIPTION

Under Worksurface Power Module – 4 Outlets, 10' Cord

- Includes 10' cord with three-prong plug.
- Fits in cable management troughs. See page 564.
- 4 outlets on side create easy access.

NOTES: Power Modules will also work with standing-height applications for 10500 Series™ and Voi® desks. For additional information see page 849.

⚠ Available in black finish only, no specification needed.

MODEL

HPWRMOD2

SHIP WEIGHT

1.5

CUBE

0.2

LIST PRICE

\$401

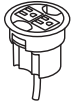

SIN 33721T

3'' Round Power Grommet – 2 Outlets, 10' Cord

- Includes 10' cord with three-prong plug.
- Fits in 3'' round grommet holes on the following product lines: Coordinate, Huddle, Motivate, all laminate and veneer casegoods series, and Systems Worksurfaces.
- Two grounded AC power outlets.
- Field installed with Plug-and-play ease.

NOTES: Power Modules will also work with standing-height applications for 10500 Series™ and Voi® desks.

⚠ Available in black finish only, no specification needed.

MODEL

HGRMTAC2

1.5

0.2

\$148



SIN 33721

Flat Bracket

24''D

30''D

⚠ Charcoal only.

⚠ Must be used if specifying 2 worksurfaces for HHAB3S3L base.

HHN831124

3.0 ~~€~~

0.3

\$64

HHN831130

3.0 ~~€~~

0.4

\$64



OPEN MARKET

Wire Managers for Height Adjustable

Trough to Floor

HMPHATFWML

2.0

0.3

\$249

HOW TO SPECIFY

Select
Model Number

H P W R M O D 2

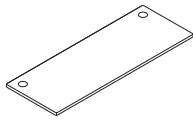

DESCRIPTION

MODEL

SHIP WEIGHT

CUBE

L1 LIST PRICE

L2 LIST PRICE

Systems Rectangle Worksurfaces for Height Adjustable Bases

46"W x 23¼"D	HHAW2448P	58	3.3	\$429	\$444
52"W x 23¼"D	HHAW2454P	64	4.0	\$451	\$471
58"W x 23¼"D	HHAW2460P	70	4.0	\$499	\$519
64"W x 23¼"D	HHAW2466P	86	4.8	\$535	\$555
70"W x 23¼"D	HHAW2472P	89	4.8	\$552	\$572

❗ Must be used as worksurfaces on Coordinate™ Height Adjustable Bases within Panel Systems, as these are 1" shorter in width on each side to provide clearance between panels and other worksurfaces.

❗ Available in all standard systems' laminate and edgebanding options. Only offered with grommets.

Specify Model.LaminateColor.EdgeColor.GrommetColor SPECIFYING EXAMPLE: HHAW2448P.A5.K.T1

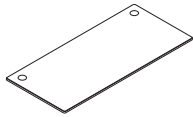

Systems Rectangle Worksurfaces for Height Adjustable Bases

46"W x 29¼"D	HHAW3048P	68	4.0	\$458	\$473
52"W x 29¼"D	HHAW3054P	80	5.0	\$491	\$511
58"W x 29¼"D	HHAW3060P	101	5.0	\$544	\$564
64"W x 29¼"D	HHAW3066P	105	6.0	\$578	\$598
70"W x 29¼"D	HHAW3072P	105	6.0	\$616	\$636

❗ Must be used as worksurfaces on Coordinate™ Height Adjustable Bases within Panel Systems, as these are 1" shorter in width on each side to provide clearance between panels and other worksurfaces.

❗ Available in all standard systems' laminate and edgebanding options. Only offered with grommets.

Specify Model.LaminateColor.EdgeColor.GrommetColor SPECIFYING EXAMPLE: HHAW3048P.A5.K.T1

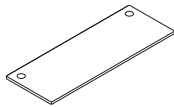

Voi® Rectangle Worksurfaces for Height Adjustable Bases

48"W x 24"D	HLSLR2448	61	3.4	\$300	\$315
54"W x 24"D	HLSLR2454	68	4.2	\$323	\$343
60"W x 24"D	HLSLR2460	75	4.2	\$351	\$371
66"W x 24"D	HLSLR2466	82	5.0	\$380	\$400
72"W x 24"D	HLSLR2472	89	5.0	\$394	\$414

48"W x 30"D	HLSLR3048	75	4.2	\$323	\$338
54"W x 30"D	HLSLR3054	84	5.1	\$360	\$380
60"W x 30"D	HLSLR3060	92	5.1	\$402	\$422
66"W x 30"D	HLSLR3066	101	6.1	\$432	\$452
72"W x 30"D	HLSLR3072	110	6.1	\$469	\$489

❗ For use with Coordinate™ Height Adjustable Bases only in Freestanding Applications, which are applications where the tables/desks are not attached or adjacent to another unit, table/desk or systems panel. The widths are true to stated dimensions. If used with Panel Systems or other than in Freestanding Applications, worksurfaces will not provide proper clearance between panels or other worksurfaces, and may cause injury or worksurface damage (not covered by warranty).

❗ Coordinate™ Height Adjustable Bases not compatible with 36"D rectangular worksurfaces.

❗ See page 188 for specifying information.

NOTES:

- Systems Rectangle Worksurfaces for Height Adjustable Bases designed for use in panel systems. Worksurface is 2" shorter in width and ¾" shorter in depth than standard worksurfaces to provide clearance between panels and other worksurfaces.

HOW TO SPECIFY

<p>Select Model Number</p> <p>See page 441</p> <p>HHAW2448P</p> <p>HLSLR2448</p>	<p>Select Laminate</p> <p>See page 441</p> <p>A5</p> <p>NN</p>	<p>Select Edge Color</p> <p>See page 441</p> <p>Specify for Systems Worksurfaces only</p> <p>K</p>	<p>Select Grommet Color</p> <p>See page 441</p> <p>Specify for Systems Worksurfaces only</p> <p>T1</p>	<p>Select Grommet Option and Color</p> <p>Specify for Voi® Worksurfaces only</p> <p>X No Grommet</p> <p>G Grommet</p> <p>If choosing the grommet option</p> <p>Select Grommet Color</p> <p>P Black</p> <p>S Charcoal</p> <p>DW Designer White</p> <p>R Greige</p> <p>LOFT Loft</p> <p>T3 Muslin</p> <p>T1 Platinum</p> <p>SD Shadow</p> <p>GR</p>
---	---	---	---	--

COORDINATE™ Worksurfaces

GSA SIN 33721



Icon Legend on page 19

WORKSTATIONS

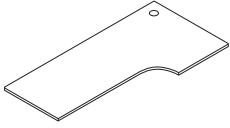

DESCRIPTION	MODEL	SHIP WEIGHT	CUBE	L1 LIST PRICE	L2 LIST PRICE
Corner Cove Worksurfaces for Height Adjustable Bases, Left Hand					
58" A x 34" B x 23" C x 23" D	HHAWV603624LP	67	6.1	\$606	\$631
70" A x 34" B x 23" C x 23" D	HHAWV723624LP	75	6.8	\$665	\$695
Corner Cove Worksurfaces for Height Adjustable Bases, Left Hand					
58" A x 46" B x 23" C x 23" D	HHAWV604824LP	85	7.4	\$665	\$695
58" A x 46" B x 29" C x 29" D	HHAWV604830LP	99	7.4	\$712	\$742
70" A x 46" B x 23" C x 23" D	HHAWV724824LP	105	8.8	\$830	\$865
70" A x 46" B x 29" C x 29" D	HHAWV724830LP	112	8.8	\$880	\$915

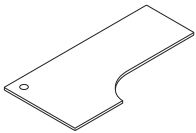
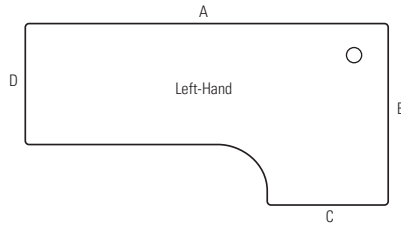

Corner Cove Worksurfaces for Height Adjustable Bases, Right Hand					
58" A x 34" B x 23" C x 23" D	HHAWV603624RP	67	6.1	\$606	\$631
70" A x 34" B x 23" C x 23" D	HHAWV723624RP	75	6.8	\$665	\$695
Corner Cove Worksurfaces for Height Adjustable Bases, Right Hand					
58" A x 46" B x 23" C x 23" D	HHAWV604824RP	85	7.4	\$665	\$695
58" A x 46" B x 29" C x 29" D	HHAWV604830RP	99	7.4	\$712	\$742
70" A x 46" B x 23" C x 23" D	HHAWV724824RP	105	8.8	\$830	\$865
70" A x 46" B x 29" C x 29" D	HHAWV724830RP	112	8.8	\$880	\$915

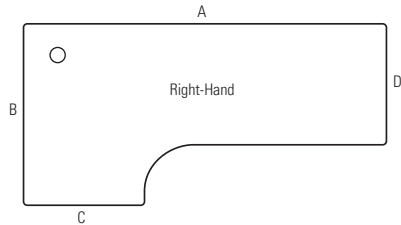

NOTES:

- Corner Cove Worksurfaces for Height Adjustable Bases designed for use in panel systems. Worksurface is 1" shorter in width and 1" shorter in depth on side of corner to provide clearance between panels and other worksurfaces.
- Use the 3-Leg Coordinate™ Base when specifying Coordinate™ Corner Cove Surfaces.

HOW TO SPECIFY

<p>Select Model Number</p> <p>HHAWV603624LP.</p>	<p>Select Laminate</p> <p>See page 441</p> <p>A5.</p>	<p>Select Edge Color</p> <p>See page 441</p> <p>K.</p>	<p>Select Grommet Color</p> <p>See page 441</p> <p>T1</p>
---	--	---	--



	DESCRIPTION	MODEL	SHIP WEIGHT	CUBE	L1 LIST PRICE	L2 LIST PRICE
	Concinnity™ Rectangle Worksurfaces					
	48"W x 24"D	HNLRC2448	40	3.1	\$274	\$289
	60"W x 24"D	HNLRC2460	50	3.9	\$325	\$345
	66"W x 24"D	HNLRC2466	55	4.2	\$353	\$373
	72"W x 24"D	HNLRC2472	60	4.6	\$366	\$386
	48"W x 30"D	HNLRC3048	50	3.9	\$301	\$316
	60"W x 30"D	HNLRC3060	62	4.7	\$369	\$389
	66"W x 30"D	HNLRC3066	69	5.2	\$395	\$415
	72"W x 30"D	HNLRC3072	75	5.6	\$429	\$449
		10500 Series™ Rectangle Worksurfaces				
48"W x 24"D		H105R2448	44	3.4	\$264	\$279
60"W x 24"D		H105R2460	55	4.2	\$311	\$331
66"W x 24"D		H105R2466	61	4.9	\$331	\$351
72"W x 24"D		H105R2472	66	4.9	\$342	\$362
48"W x 30"D		H105R3048	55	4.1	\$286	\$301
60"W x 30"D		H105R3060	69	5.2	\$349	\$369
66"W x 30"D		H105R3066	76	6.1	\$374	\$394
72"W x 30"D		H105R3072	83	6.1	\$402	\$422

NOTES:

- ❗ For use with Coordinate™ Height Adjustable Bases only in freestanding applications, which are applications where the tables/desks are not attached or adjacent to another unit, table/desk, or systems panel. The widths are true to stated dimensions. If used with Panel Systems or other than in freestanding applications, worksurfaces will not provide proper clearance between panels or other worksurfaces, and may cause injury or worksurface damage (not covered by warranty).
- ❗ Coordinate™ Height Adjustable Bases are not compatible with 36"D rectangular worksurfaces.

HOW TO SPECIFY

<p>Select Model Number</p>	<p>Select Worksurface Laminate and Edge Color</p> <p><i>For Concinnity™ Worksurfaces see page 29</i> <i>For 10500 Series™ Worksurfaces see page 236</i></p>	<p>Select Worksurface Grommet Finish</p> <p><i>Specify for Concinnity™ Worksurfaces only</i></p> <p>P Black TI Platinum X No Grommet</p>	<p>Select Worksurface Color</p> <p><i>Specify for Concinnity™ Worksurfaces only. See page 29.</i></p>
<p>H N L R C 2 4 4 8</p> <p>H 1 0 5 R 2 4 4 8</p>	<p>B H</p> <p>N N</p>	<p>P</p>	<p>H</p>

COORDINATE™

Shared Components

GSA SIN 33721



Icon Legend on page 19

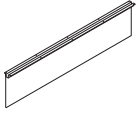

DESCRIPTION	MODEL	SHIP WEIGHT	CUBE	L1	L2
				LIST PRICE	UPCHARGE
Laminate Floating Modesty Panel					
30"W x 14"H	HLSL3014L	10	0.8	\$169	\$10
36"W x 14"H	HLSL3614L	12	0.8	\$179	\$10
42"W x 14"H	HLSL4214L	14	0.8	\$193	\$10
48"W x 14"H	HLSL4814L	16	1.1	\$212	\$12
54"W x 14"H	HLSL5414L	18	1.1	\$232	\$12
60"W x 14"H	HLSL6014L	20	1.1	\$250	\$12

NOTES: The attachment bracket and modesty panel are packaged separately.
Specify: Model.Laminate.Paint

SPECIFYING EXAMPLE: HLSL3014L.N.P (Black is the only paint option for this model)

- ⓘ When specifying the 54"W or 60"W Laminate Floating Modesty Panel, it is not necessary to specify an external channel.
- ⓘ 30"W and 36"W screens attach with L-brackets, not the external channel.

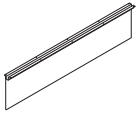

DESCRIPTION	MODEL	SHIP WEIGHT	CUBE	LIST PRICE
Mixed Material Floating Modesty Panel				
30"W x 14"H	HLSL3014MM	8	2.0	\$676
36"W x 14"H	HLSL3614MM	8	2.0	\$726
42"W x 14"H	HLSL4214MM	9	2.3	\$811
48"W x 14"H	HLSL4814MM	11	2.6	\$898
54"W x 14"H	HLSL5414MM	13	3.3	\$974
60"W x 14"H	HLSL6014MM	13	3.3	\$1113

NOTES: The attachment bracket and modesty panel are packaged separately.
Specify: Model.Mixed Material.Paint

SPECIFYING EXAMPLE: HLSL3014MM.FT01.P (Frosted Translucent mixed material and Black paint are the only options for this model)

- ⓘ When specifying the 54"W or 60"W Mixed Material Floating Modesty Panel, it is not necessary to specify an external channel.

NOTES:

- When using a floating modesty panel under the worksurface, the depth clearance for center drawers and keyboard platforms decreases by 8".

HOW TO SPECIFY

<p>Select Model Number</p>	<p>Select Mixed Material</p> <p>FT01 Frosted Translucent</p>
<p>H L S L 3 0 1 4 M M .</p>	<p>F T 0 1</p>



SYSTEMS Worksurface Supports

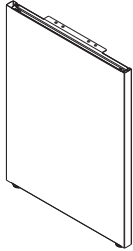

Specify paint

DESCRIPTION	MODEL	SHIP WEIGHT	CUBE	LIST PRICE BY PAINT GRADE	
				P1	P2
Abound® and Accelerate® Full End Panel*					
29½”H x 11”D — Right — Panel Mount	HRVEP1129R	16 Ⓢ	1.4	\$207	\$236
29½”H x 11”D — Left — Panel Mount	HRVEP1129L	16 Ⓢ	1.4	\$207	\$236
29½”H x 24”D — Right — Panel Mount	HRVEP2429R	21 Ⓢ	1.4	\$223	\$252
29½”H x 24”D — Left — Panel Mount	HRVEP2429L	21	1.4	\$223	\$252
29½”H x 30”D — Right — Panel Mount	HRVEP3029R	23	1.4	\$242	\$271
29½”H x 30”D — Left — Panel Mount	HRVEP3029L	23	1.4	\$242	\$271

NOTES: The use of an end panel at the end of a worksurface will increase the rigidity of the workstation. If the panel is a greater dimension than the worksurface, an end panel is required if the run of the worksurfaces is 8 feet or greater. Levelers provide 1½” vertical adjustment.

- ⚠ *Must be connected into panel slots. When an installation of worksurfaces is 8 feet or greater, a full end panel or universal support leg must be used at 90 degree panel junctions or in a shared position to support adjoining worksurfaces.
- ⚠ End panel support with bracket will attach to both Accelerate® and Abound® panels.

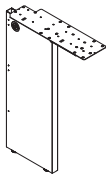

Non-handed unit
Specify paint

Abound® and Accelerate® Universal Support Leg*					
29½”H to support 24”D	HRVCLG24	16 Ⓢ	1.4	\$197	\$226
29½”H to support 30”D	HRVCLG30	17 Ⓢ	1.4	\$215	\$244

NOTES: Use at 90° panel junctions or in a shared position to support adjoining worksurfaces. Provided with flat bracket. Levelers provide 1½” vertical adjustment.

- ⚠ *Must be connected into panel slots. When an installation of worksurfaces is 8 feet or greater, a full end panel or universal support leg must be used at 90 degree panel junctions or in a shared position to support adjoining worksurfaces.

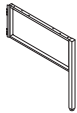

Open Leg Models*					
29½”H x 12”D	HOLEG12	7 Ⓢ	0.5	\$147	\$176
29½”H x 24”D	HOLEG24	11 Ⓢ	1.2	\$207	\$236
29½”H x 30”D	HOLEG30	15 Ⓢ	1.8	\$225	\$254

NOTES: Open leg includes attaching hardware and leveling glides. Leveling glides provide 2¼” of adjustment. Open leg is universal shared with a left- and right-hand attachment bracket.

- ⚠ *Must be connected into frame slots. Specify paint.

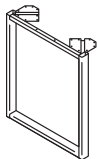

O-Leg Support for Worksurfaces					
20”D x 28½”H	HLSL2028O	15	3.7	\$292	\$296
24”D x 28½”H	HLSL2428O	17	3.7	\$316	\$320
30”D x 28½”H	HLSL3028O	19	5.4	\$352	\$356

NOTES: Ship fully assembled, 1/pack. Non-handed. Use the anti-dislodgement bracket when using a worksurface in a peninsula application with a post or O-leg.

DESCRIPTION	MODEL	SHIP WEIGHT	CUBE	LIST PRICE BY PAINT GRADE		
				P1	P2	P3
Voi® for Systems O-Leg-to-Panel Attachment Bracket						
Left handed bracket (quantity 1)	HLSLPBL	3 Ⓢ	0.4	\$100	\$104	N/A
Right handed bracket (quantity 1)	HLSLPBR	3 Ⓢ	0.4	\$100	\$104	N/A

NOTES: Used to connect Voi O-Leg to a systems panel for additional workstation rigidity. Bracket designed to work with edgeband worksurfaces only. Brackets are handed, come one per package and include self-tapping screws. Specify paint.

NOTES:

- The supports included on this page can be used with Systems and Worksurfaces.

HOW TO SPECIFY

<p>Select Model Number</p> <p>HRVEP1129R .</p>	<p>Select Paint Color</p> <p>See page 171</p> <p>T1</p>
--	---

SYSTEMS

Worksurface Supports

GSA SIN 33721



Icon Legend on page 19

WORKSTATIONS

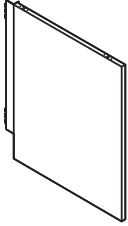

DESCRIPTION	MODEL	SHIP WEIGHT	CUBE	LIST PRICE BY PAINT GRADE	
				P1	P2
Laminate End Panel Support with Panel Bracket					
29½"H x 24"D, Left handed	HLSL2428EBL	3	2.2	\$258	\$262
29½"H x 24"D, Right handed	HLSL2428EBR	3	2.2	\$258	\$262
29½"H x 30"D, Left handed	HLSL3028EBL	3	3.2	\$274	\$278
29½"H x 30"D, Right handed	HLSL3028EBR	3	3.2	\$274	\$278

NOTES: Includes laminate end panel and brackets to attach end panel support to a panel. Order to correspond to worksurface depth. Specify laminate and paint. Can be used with Abound® and Accelerate® Systems products.

NOTES:

- The supports included on this page and on previous page can be used with Systems and Worksurfaces.

HOW TO SPECIFY

<p>Select Model Number</p> <p>H L S L 2 4 2 8 E B L .</p>	<p>Select Laminate</p> <p>L2 Laminate Upcharge \$10 See page 441</p> <p>H .</p>	<p>Select Paint Color</p> <p>See page 441</p> <p>T 1</p>
--	--	---



SYSTEMS Worksurface Supports

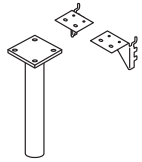

Non-handed unit
Specify paint

DESCRIPTION

Support Column*

For 29½" Height. 3" diameter.

NOTES: Used to support one end of a peninsula, round or half-round worksurface. (Includes panel support brackets.) Levelers provide 1½" vertical adjustment.

! *Brackets must be connected into panel slots.

MODEL	SHIP WEIGHT	CUBE	LIST PRICE BY PAINT GRADE	
			P1	P2

HCNLEG29	13 Ⓞ	1.1	\$217	\$244
-----------------	-------------	-----	--------------	--------------



Post Leg Base

- Single Post Leg with Hardware Pack
- Requires hardware bracket model HWSA2. Please see below for HWSA2 bracket ordering information.

HMBPOST1	18	2.3	\$294	\$306
-----------------	----	-----	--------------	--------------

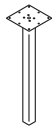

Post Leg Base

28½"H x 2" square

NOTES: Requires hardware bracket model HWSA2 when used to support a peninsula.

HLSL28P	15	1.0	\$292	\$296
----------------	----	-----	--------------	--------------

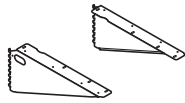

Specify paint

Accessory Cantilever*

- 18"D Pair
- 24"D Pair
- 18"D Right-Hand Cantilever
- 18"D Left-Hand Cantilever
- 24"D Right-Hand Cantilever
- 24"D Left-Hand Cantilever

HCTL182	4 Ⓞ	0.3	\$65	\$75
HCTL242	5 Ⓞ	0.3	\$84	\$94
HCTL181R	3.2 Ⓞ	0.2	\$35	\$45
HCTL181L	3.2 Ⓞ	0.2	\$35	\$45
HCTL241R	3.7 Ⓞ	0.6	\$45	\$55
HCTL241L	3.7 Ⓞ	0.6	\$45	\$55

! *Must be connected into panel slots.

! Accelerate® only: Cantilevers only to be used on worksurface runs 72"W or less.

! Use with runs 72" or less – avoid installation on only one side of a straight connection except to support corner worksurfaces. Floor support is required for runs longer than 72".

! DO NOT position at the end of a panel run where no 90 degree return panel is positioned.

! DO NOT use to support worksurfaces from which a hanging pedestal is suspended, or to which a peninsula worksurface is attached.

! DO NOT use cantilever brackets to support worksurfaces supported with permanent wall hanger kit.

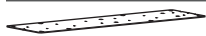

Flat Bracket

- 18"D
- 24"D
- 30"D

HHN831118	3 Ⓞ	0.2	\$63	N/A
HHN831124	3 Ⓞ	0.3	\$64	N/A
HHN831130	3 Ⓞ	0.4	\$64	N/A

NOTES: Flat Brackets can be used to connect one worksurface perpendicular to another worksurface.

! Charcoal only.

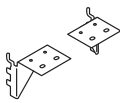

Specify paint

Worksurface Bracket Kit*

One Pair

HWSB2	1 Ⓞ	0.1	\$46	\$49
--------------	------------	-----	-------------	-------------

NOTES: Used to connect the end of a worksurface to a panel of the same width.

! Always use when the depth side of a worksurface is against a panel (return/wing panel) of the same dimension. This will increase the sturdiness of the workstation.

! *Must be connected into panel slots.

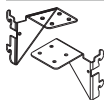

Anti-Dislodgement Bracket Kit

HWSA2	1	0.1	\$44	\$47
--------------	---	-----	-------------	-------------

NOTES: To be used with models HMBPOST1 and HLSL28P Post Leg Base.

NOTES:

- The supports included on this page can be used with Systems Worksurfaces.

HOW TO SPECIFY

<p>Select Model Number</p> <p>H C T L 2 4 2 .</p>	<p>Select Paint Color</p> <p>See page 441</p> <p>T 1</p>
--	---



Icon Legend on page 19

WORKSURFACE BRACKETS

WORKSTATIONS



DESCRIPTION	MODEL	SHIP		LIST PRICE BY PAINT GRADE		
		WEIGHT	CUBE	P1	P2	P3
Flagship® Pedestal to Panel Bracket Kit, Left	HPD2PNBRK2L	3.0	0.3	\$107	\$115	\$117
Flagship® Pedestal to Panel Bracket Kit, Right	HPD2PNBRK2R	3.0	0.3	\$107	\$115	\$117

NOTES: Bracket to attach 22⁷/₈"D pedestals to 24"D worksurface or 28⁷/₈"D pedestals to 30"D worksurface.



DESCRIPTION	MODEL	SHIP WEIGHT	CUBE	P1	P2	P3
Worksurface to Tower Bracket Kit Bracket to attach storage towers to worksurfaces.	HSTB2W1	4.0	0.6	\$76	\$89	\$100

NOTES: Replaces the need for a panel attached end panel. Standard with hardware to attach bracket to panel and worksurface.

- Bracket cannot be used as a support when placing Stack-on Storage on worksurface over bracket. Must use two full-sized supports when using Stack-on Storage.
- Not for use with systems support pedestals.

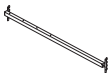

DESCRIPTION	MODEL	SHIP WEIGHT	CUBE	P1	P2	P3
Worksurface-to-Wing Panel Bracket 24"W	HWSR24	2.5	0.4	\$57	N/A	N/A
30"W	HWSR30	3.0	0.4	\$57	N/A	N/A
36"W	HWSR36	3.5	0.5	\$57	N/A	N/A
42"W	HWSR42	4.0	0.5	\$57	N/A	N/A
48"W	HWSR48	4.5	0.6	\$57	N/A	N/A

NOTES:

- To be used when the adjacent wing panel is wider than the worksurface depth.
- Specify support to the same width as your adjacent wing panel, not the depth of your worksurface.
- Support spans the entire width of the wing panel.
- Supports are non-handed.

HOW TO SPECIFY

<p>Select Model Number</p> <p>HPD2PNBRK2L .</p>	<p>Select Paint Color</p> <p>See page 441</p> <p>T1</p>
---	---



Icon Legend on page 19

SYSTEMS Worksurface Supports

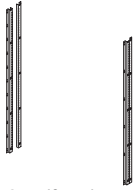

Specify paint

DESCRIPTION	MODEL	SHIP WEIGHT	CUBE	LIST PRICE BY PAINT GRADE	
				P1	P2
Abound® and Accelerate® Permanent-Wall Hanger Kit Wall Hanger Kit (2 pieces) 2 1/8"W x 1/8"D x 66"H	HRVC35PCE	6.0	0.7	\$218	\$238
Wall Hanger Kit 4 1/4"W x 1/8"D x 66"H	HRVC35PCM	3.0	0.7	\$114	\$124

NOTES: Anchor devices are not supplied with these models. Refer to Abound® or Accelerate® Installation instructions for appropriate hardware. Used to hang storage cabinets and bookshelves from permanent wall, and/or to attach worksurfaces to permanent wall.

- Attachment to masonry walls is not recommended.
- Worksurfaces should not be supported with Cantilever brackets when using Permanent-Wall Hanger Kit.

NOTES:

- Wall track has 1/8" x 1/2" slots on 1" centers.
- Customer to furnish connecting hardware. (Refer to Installation Instructions for appropriate hardware.)
- Includes a cover for top of channel.

HOW TO SPECIFY

<p>Select Model Number</p> <p>HRVC35PCE</p>	<p>Select Paint Color</p> <p>See page 441</p> <p>T1</p>
--	--

STANDING-HEIGHT WORKSURFACE SUPPORTS

GSA SIN 33721



Icon Legend on page 19

WORKSTATIONS

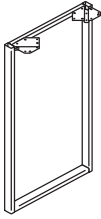

DESCRIPTION

Standing-Height O-Leg Support for Worksurfaces

24"D x 41"H

30"D x 41"H

NOTES: Ship fully assembled, 1/package. Non-handed.

MODEL

SHIP WEIGHT

CUBE

LIST PRICE BY PAINT GRADE

P1

P2

HLSL24410

16

5.3

\$424

\$430

HLSL30410

17

6.5

\$474

\$480

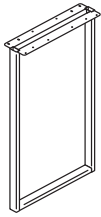

Standing-Height O-Leg Shared Support for Worksurfaces

24"D x 41"H

30"D x 41"H

NOTES: Ship fully assembled, 1/package. Non-handed.

HLSL2441SL

16

5.3

\$478

\$484

HLSL3041SL

17

6.5

\$529

\$535

NOTES:

- O-leg glides have 2" adjustability.
- Shared O-legs create a cleaner aesthetic in all applications where two legs are used side-by-side.
- O-Leg to Panel Attachment Brackets are used to connect Voi® O-Legs to a systems panel for additional worksurface rigidity.

❗ O-legs may only be attached to worksurfaces, not storage units.

HOW TO SPECIFY

Select Model Number

Select Paint Color

See page 171

HLSL24410

T1

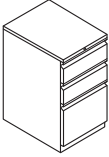
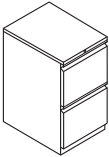
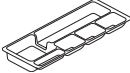

Standard Height Support Pedestals

	DESCRIPTION	MODEL	SHIP WEIGHT	CUBE	LIST PRICE BY PAINT GRADE		
					P1	P2	P3
	Standard Height Freestanding Support Pedestals — Box/Box/File						
	15"W x 19 7/8"D x 28"H	HVFB20R	89.0	7.0	\$523	\$551	\$567
	15"W x 22 7/8"D x 28"H	HVFB23R	95.0	8.0	\$538	\$566	\$583
	Standard Height Freestanding Support Pedestals — File/File						
	15"W x 19 7/8"D x 28"H	HVFF20R	88.0	7.0	\$518	\$546	\$562
	15"W x 22 7/8"D x 28"H	HVFF23R	94.0	8.0	\$533	\$561	\$578
	Optional Pencil Tray	HV-UT1	0.5	0.1	\$66	N/A	N/A
	NOTES: For additional information see page 846.						
	! For use with mobile and freestanding pedestal models shown above.						

NOTES:

- 28"H fits under all HON worksurfaces and desk shells.
- Ball-bearing suspension on file drawer (90% extension), and box drawer (90% extension on both drawers).
- File drawers have high sides for filing front-to-back.
- Available in "R" pull only.
- Pencil tray standard in top box drawer.
- One box divider standard in each box drawer.
- One crossrail standard in each file drawer.

! Freestanding models must be used under a worksurface only.

HOW TO SPECIFY

<p>Select Model Number</p> <p>H V F B 2 0 R .</p>	<p>Select Lock Option</p> <p>L Lock (no upcharge)</p> <p>L .</p>	<p>Select Paint Color</p> <p>See page 441</p> <p>P</p>
--	---	---

VOI® Laminate Support Pedestals

GSA SIN 33721



Icon Legend on page 19

WORKSTATIONS

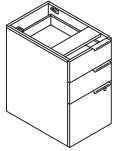

DESCRIPTION

Support Pedestals — Box/Box/File

16"W x 20"D x 28½"H
16"W x 24"D x 28½"H
16"W x 30"D x 28½"H

NOTES: Top box drawer does not lock.

MODEL	SHIP WEIGHT	CUBE	L1 LIST	L2 UPCHARGES	
				CHASSIS	FRONTS
HLSL2028B	73	7.3	\$689	\$15	\$10
HLSL2428B	85	8.5	\$762	\$20	\$10
HLSL3028B	105	10.5	\$859	\$25	\$10

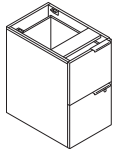

Support Pedestals — File/File

16"W x 20"D x 28½"H
16"W x 24"D x 28½"H
16"W x 30"D x 28½"H

HLSL2028F	72	7.3	\$689	\$15	\$10
HLSL2428F	84	8.5	\$762	\$20	\$10
HLSL3028F	104	10.5	\$859	\$25	\$10

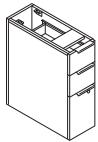

Slim Profile Pedestals — Box/Box/File

9½"W x 24"D x 28½"H
9½"W x 30"D x 28½"H

NOTES: Top box drawer does not lock.

HLSL2428S	69	6.9	\$756	\$20	\$10
HLSL3028S	56	5.6	\$831	\$25	\$10

NOTES:

- Please see Voi® section of the pricer for full Voi® laminate offering, which is compatible with all HON systems series.
 - Voi® Support and Power-Ready Pedestals can be used with worksurfaces.
 - A variety of pedestals, end panels, and O-legs can be combined to create a conventional or contemporary desk.
 - Chassis and drawer front woodgrain and solid laminates are specified separately (see SIF options below).
 - File drawers accept hanging folders in letter or legal size.
 - Multiple handle locations possible per customer preference.
 - Ships with one handle per drawer.
 - Drawer Organizer model HSLDRWORG works with box drawers.
 - Box and file drawers operate on ball-bearing suspension with full extension.
 - Adjustable hex leveling glides allow floor-standing furniture to be easily leveled without lifting the unit; glides have ¼" adjustable range.
- ❗ Pedestals ship fully assembled but must attach to a worksurface with a quick release bracket, provided. Pedestals are non-handed and are interchangeable.
- ❗ Locking units equipped with HON "One Key" interchangeable core removable locks. Keyed alike core must be ordered separately.



HOW TO SPECIFY

Select Model Number H L S L 2 0 2 8 B	Select Chassis Laminate See page 171 N	Select Drawer Front Laminate See page 171 N	Select Pull Color P Black T4 Champagne T1 Platinum PJW Designer White PR6 Silver P8X Solar Black T 4
--	--	---	---

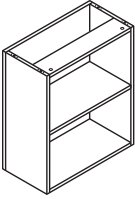

Icon Legend on page 19

Laminate Support Storage

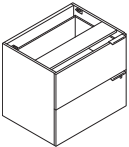
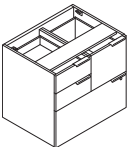
	DESCRIPTION	MODEL	SHIP WEIGHT	CUBE	L1 LIST	L2 UPCHARGES	
						CHASSIS	FRONTS
	Bookcase Support 24"W x 12"D x 28½"H 30"W x 12"D x 28½"H	HLSL240BC HLSL300BC	60 75	3.0 3.0	\$511 \$535	\$20 \$25	N/A N/A
							
	Lateral File — 2 Drawer 31⅜"W x 24"D x 28½"H	HLSL2430L	121	15.6	\$1184	\$35	\$20
	Multi File Lateral File 31⅜"W x 24"D x 28½"H NOTES: Box drawers do not lock.	HLSL2430MF	163	15.6	\$1404	\$35	\$20

NOTES:

- Voi® Support and Power-Ready Storage can be used with Systems Worksurfaces.
- Ships with one handle per drawer on all units.
- A variety of pedestals, end panels, and O-legs can be combined to create a conventional or contemporary desk.
- Bookcase can only mount exterior facing under a worksurface.
- Chassis and drawer front woodgrain and solid laminates are specified separately (see SIF options below).
- File drawers accept hanging folders in letter or legal size.
- Multiple handle locations possible per customer preference.
- Storage accessory model HLSLDRWORG works with box doors.
- Standard box drawers operate on ball-bearing suspension with full extension. File, lateral, and wide box drawers operate on ball-bearing suspension with full extension.
- Adjustable hex leveling glides allow floor-standing furniture to be easily leveled without lifting the unit; glides have 2" adjustable range.
- When using two lateral files, a 60" worksurface cannot be used, a 66" worksurface must be specified, which will show a gap.
- ! Cannot fit binders on both shelves of bookcase model HLSL240BC and HLSL300BC.
- ! Must be specified under a worksurface 60"W or wider.
- ! Locking units equipped with HON "One Key" interchangeable core removable locks. Keyed alike core must be ordered separately.

HOW TO SPECIFY

<p>Select Model Number</p> <p>H L S L 2 4 3 0 L</p>	<p>Select Chassis Laminate</p> <p>See page 171</p> <p>N</p>	<p>Select Laminate</p> <p>See page 171</p> <p>N</p>	<p>Select Pull Color</p> <p>P Black T4 Champagne T1 Platinum PJW Designer White PR6 Silver P8X Solar Black</p> <p>T 4</p>
--	--	--	---

SYSTEMS

Accessories — Paper Management /

GSA SIN 33721 EXCEPT AS NOTED



Icon Legend on page 19

WORKSTATIONS

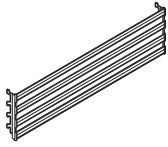

DESCRIPTION	MODEL	SHIP WEIGHT	CUBE	LIST PRICE BY PAINT GRADE		
				P1	P2	P3
Paper Management Support Bars						
24"W x 5"H	HNPBWSW24	1.3 Ⓞ	0.4	\$196	\$208	\$218
30"W x 5"H	HNPBWSW30	1.5 Ⓞ	0.5	\$209	\$221	\$231
36"W x 5"H	HNPBWSW36	2.0 Ⓞ	0.6	\$216	\$228	\$238
42"W x 5"H	HNPBWSW42	5.0 Ⓞ	0.7	\$228	\$240	\$250
48"W x 5"H	HNPBWSW48	7.0 Ⓞ	0.8	\$237	\$249	\$259
60"W x 5"H	HNPBWSW60	9.0 Ⓞ	0.9	\$269	\$281	\$291

ⓘ Recommended weight capacity not to exceed 80 pounds. Paper management bar attaches to Systems panels/frames to accommodate work flow accessories.



Paper Shelf 15"W x 9½"D x 2"H	HPPMPS	2.0 Ⓞ	0.3	\$97	\$109	\$120
---	--------	-------	-----	------	-------	-------

NOTES: Holds letter size paper and inter-office envelopes.

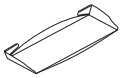

Accessory Shelf 21¾"W x 7"D x 2"H	HPPMAS	2.0 Ⓞ	0.3	\$101	\$113	\$124
---	--------	-------	-----	-------	-------	-------

NOTES: Holds office supplies and personal effects.



Phone Tray 9"W x 10¾"D x 2"H	HPPMPT	2.0 Ⓞ	0.3	\$124	\$136	\$147
--	--------	-------	-----	-------	-------	-------

NOTES: Holds telephone at optimum ergonomic angle.



CD/Pencil Holder 5¼"W x 1½"D x 5"H	HPPMPB	1.0 Ⓞ	0.2	\$101	\$113	\$124
--	--------	-------	-----	-------	-------	-------

NOTES: Can store up to 3 CD jewel cases; sticky pads or writing instruments.



Sorter Tray 6"W x 10"D x 2½"H	HPPMST	2.0 Ⓞ	0.3	\$133	\$145	\$156
---	--------	-------	-----	-------	-------	-------

NOTES: Provides 3 slots for organizing files.

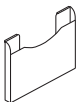

Folder Bin 12¼"W x 1¼"D x 9"H	HPPMFB	2.0 Ⓞ	0.3	\$101	\$113	\$124
---	--------	-------	-----	-------	-------	-------

NOTES: Accommodates manila envelopes and can be hung from other folder binds to maximize storage.

DESCRIPTION	MODEL	SHIP WEIGHT	CUBE	LIST PRICE
36"W x 24"H	HHRK36	15.0 Ⓞ	3.2	\$509
42"W x 24"H	HHRK42	17.0 Ⓞ	4.0	\$553
48"W x 24"H	HHRK48	19.0 Ⓞ	4.6	\$595

ⓘ No color specification required.

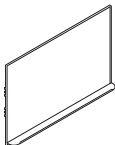

Back Pack Hook (10 per carton) 12"W x 14½"D x 1½"H	HCLA65	10.0 Ⓞ	0.1	\$94
--	--------	--------	-----	------

NOTES: Assembly; attaches to bottom of desk with (2) screws, included. For additional information see page 846.

ⓘ Available in Titanium finish only, no specification needed.

OPEN MARKET



HOW TO SPECIFY

Select Model Number

Select Paint Color

See page 824

H N P M B S W 2 4 .

P 8 S



SYSTEMS Accessories — Task Lights

	DESCRIPTION	MODEL	SHIP WEIGHT	CUBE	LIST PRICE
	Articulating Desk Lamp Articulating Desk Lamp w/ Occupancy Sensor <ul style="list-style-type: none"> • Color: Matte Silver. • Full-range dimming from 10% to 100%. • Designed for 50,000 hours of life. • Occupancy sensor is built into the head of the lamp and will automatically shut the lamp off after 6 minutes of undetected movement. • Base swivel is 180 degrees. • Uses only 5 watts of energy. • Light comes with a silver 9' 4" power cord. • Base diameter is 7.5". • 3500K Color Temperature. • 80 Color Rendering Index. • TAA Compliant. 	HLED1 HLED10C	1.2 Ⓢ 1.2 Ⓢ	6.5 6.5	\$402 \$490
	Task Desk Lamp <ul style="list-style-type: none"> • Color: Brushed Nickel. • Full-range dimming from 10% to 100%. • Designed for 50,000 hours of life. • Lamp is 15.83" tall. • Desk lamp does not articulate at base. The pivoting head provides custom positioning, as it can be twisted 360 degrees. • Uses only 5 watts of energy. • Light comes with a silver 9' 4" power cord. • Base diameter is 6.7". • 3500K Color Temperature. • 80 Color Rendering Index. • TAA Compliant. 	HLED2	0.7 Ⓢ	3.0	\$348

NOTES:

- For additional information see page 841.

HOW TO SPECIFY

Select Model Number

HLED1

SYSTEMS

Accessories — Electrical

GSA SIN 33721

ABI

Icon Legend on page 19

WORKSTATIONS

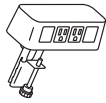

DESCRIPTION

Power & Data Center

2 Receptacles 2 Data Accessory

- Standard with two receptacles and openings for two data ports.
- 6' power cord with standard three-prong plug.
- Fits on any worksurface with a 4" overhang.
- UL Listed.

! Color finish coordinates with HON's Loft. Specify LOFT when ordering. Example: HCOMDOME2.LOFT

MODEL

HCOMDOME2

SHIP WEIGHT

2.5 **Ⓢ**

CUBE

0.2

LIST PRICE

\$293

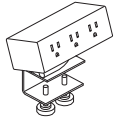

Model HPWRMOD3WC shown

Power Modules

3 Receptacles with Worksurface Clamp

3 Receptacles with Under-Worksurface Mounting Bracket

2 Receptacles 2 USB with Worksurface Clamp

2 Receptacles 2 USB with Under-Worksurface Mounting Bracket

• 6' power cord with standard three-prong plug.

• Under-worksurface mounting bracket models work with any top that has a 5" x 5" square clearance.

• Worksurface clamp models work on any top with a 4" overhang.

• UL Listed.

! Color finish coordinates with HON's Charcoal or White. Specify STRM for Storm and SNW for Snow when ordering.

Example: HPWRMOD3WC.STRM

HPWRMOD3WC

2.3 **Ⓢ**

0.2

\$307

HPWRMOD3UWM

2.3 **Ⓢ**

0.2

\$307

HPWRMOD2WC

2.3 **Ⓢ**

0.2

\$491

HPWRMOD2UWM

2.3 **Ⓢ**

0.2

\$491

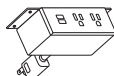

Model HPWRMOD2UWM shown

Under Worksurface Power Module — 4 Outlets, 10' Cord

HPWRMOD2

1.5

0.2

\$401

• Includes 10' cord with three-prong plug.

• Fits in cable management troughs. See page 564.

• 4 outlets on side create easy access.

NOTES: Power Modules will also work with standing-height applications for 10500 Series™ and Voi® desks.

! Available in black finish only, no specification needed.

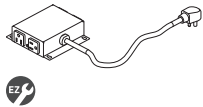

Vertebrae

HMPVWM28

3.0

0.3

\$221

NOTES: 30"H x 3 3/8"W x 1 1/2"D. Ships unassembled.

! Clear finish. Specify "X" for finish option.

SPECIFYING EXAMPLE: HMPVWM28.X

NOTES:

- For additional information see page 849.

SYSTEMS

Accessories — Monitor Arms

OPEN MARKET EXCEPT AS NOTED



Icon Legend on page 19

WORKSTATIONS

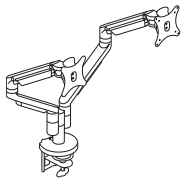

DESCRIPTION

Dual Dynamic Monitor Arm

- 150° of rotation at base with optional 360° rotation.
- Arms extend 22" and retract up to 3".
- Monitor mount rotates 180° and tilts +/-30°.
- Monitor can be rotated from landscape to portrait position.

! Arms hold monitors from 6.2-18 lbs. Optional counterweight HPACW available to support monitors as low as 5 lbs. (see page 827).

MODEL	SHIP WEIGHT	CUBE	LIST PRICE
HMASD	17.0	1.1	\$750

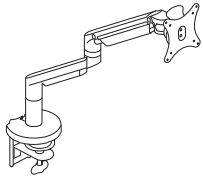

Single Dynamic Monitor Arm

- 180° of rotation at base with optional 360° rotation.
- Arms extend 22" and retract up to 3".
- Monitor mount rotates 180° and tilts +/-30°.
- Monitor can be rotated from landscape to portrait position.

! Arms hold monitors from 6.2-18 lbs. Optional counterweight HPACW available to support monitors as low as 5 lbs. (see page 827).

HMASTS	11.5	0.8	\$390
---------------	------	-----	--------------

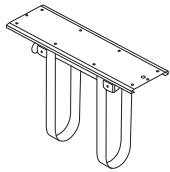

360° Swivel CPU Holder with Adjustable Straps

- Supports CPUs 3 3/4" wide up to 64" perimeter and holds up to 75 lbs.
- 360° rotation.
- Ships complete and includes necessary mounting hardware and instruction sheet.

! Available in Black only, no specification needed.

HCPU1	7.0	0.2	\$243
--------------	-----	-----	--------------

SIN 33721

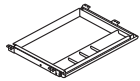

Polymer Center Drawer

- Color: Black.
- Material: ABS.
- Opening Requirements: 23"W x 16 1/4"D x 2"H.
- Retracts on 16" ball-bearing slides.
- Can be used on worksurfaces with Coordinate™ Height Adjustable Bases as long as it is attached with spacer model HKBS.
- Can store up to 25 lbs.

NOTES: For additional information see page 833.

! Black finish only, no specification needed.

HCD1	7.0	0.5	\$108
-------------	-----	-----	--------------

NOTES:

- See pages 825-826 for additional monitor arm models.

HOW TO SPECIFY

Select Model Number

HMASD

Select Finish

Specify for models HMASD and HMASTS only

SVR Silver
BLK Black

SVR

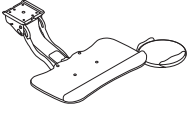
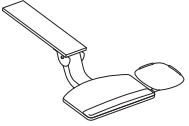
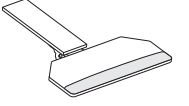
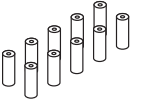

SYSTEMS Accessories — Keyboard Platforms

	DESCRIPTION	MODEL	SHIP WEIGHT	CUBE	LIST PRICE
	<p>Sit to Stand Arm with Keyboard Platform</p> <ul style="list-style-type: none"> • Sit to stand application. • No knob or lever for adjustment, simply lift into place. • One-hand tilt adjustment for maximum flexibility. • Height adjustment without levers. • +10°/-20° tilt adjustment. • Height adjustment 12½" (7" above and 5½" below). • For use on surfaces 24" or deeper. • Tilt and swivel mouse surface with gel palm rest. • Detachable palm rest. • Mouse pad can mount right or left. <p>! Black only finish, no specification needed.</p>	H2516 *	17 Ⓔ	1.6	\$618
	<p>Articulating Arm with Convertible Keyboard Platform</p> <ul style="list-style-type: none"> • 21" glide track. • Lift and lock height adjustment. • Height adjustment 7" (2½" above and 4½" below track). • Release handle for independent tilt adjustment. • Tilt: +/-15°. • Independent tilt and swivel mousing platform. • Positions platform flush with worksurface. • Mouse can be used in-line, over, or forward at platform height or above. • Mouse can be placed at platform height or above height. • Left or right handed mousing; no tools required. • Detachable palm rest. • Cord management clips included. <p>! Black only finish, no specification needed.</p>	H2107 *	16 Ⓔ	1.3	\$529
	<p>Articulating Arm with Keyboard Platform</p> <ul style="list-style-type: none"> • 17" glide track. • Spring assisted. • Height adjustment 6¼" (1¼" above and 5" below track). • Tilt: +10°/-15°. • 25" cut corner platform. • Accommodates keyboard and mouse on same level. • Detachable palm rest. • Cord management clips included. <p>! Black only finish, no specification needed.</p>	H1706 *	16 Ⓔ	1.4	\$493
	<p>Keyboard Spacer</p> <ul style="list-style-type: none"> • For use when attaching a keyboard tray to Coordinate™ and Voi® or Systems Worksurface with an external channel. • The kit includes ten cylinder spacers and ten screws. • Spacers are ¾"W x 2½"H. • Specify one kit per keyboard tray. 	HKBS	1 Ⓔ	0.8	\$90

NOTES:

• For additional information see page 829.

* De-emphasized.

HOW TO SPECIFY

Select Model Number

H 2 5 1 6

SYSTEMS Accessories

OPEN MARKET

Icon Legend on page 19

WORKSTATIONS

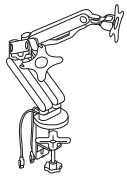
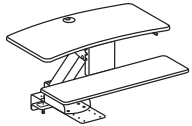
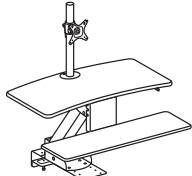
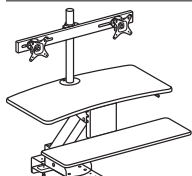
	DESCRIPTION	MODEL	SHIP WEIGHT	CUBE	LIST PRICE
	<p>Coordinate™ Portable Desktop Riser 31"D x 5'-16½"H x 35"W</p> <p>NOTES: Available in Black (BLK) or White (WHT) finish. Desktop riser dimensions (without keyboard tray): 22"D x 5'-16½"H x 35"W. Keyboard tray dimensions: 9"D x 30"W. Max loading capacity is 33 lbs for the desktop riser surface and 4 lbs for the keyboard tray. Easily transition from seated to standing positions throughout the workday. Sits atop an existing desk to create sit-to-stand functionality by raising the computer. Includes keyboard tray and surface for computer monitors. HON 5-Year Limited Warranty.</p> <p>⚠ Not intended for use on mobile workstations.</p>	HBXRISER	54.0	4.1	\$619
	<p>Dual Monitor Arm with 2 USB Ports</p> <p>NOTES: Easy adjustment. Height adjusts to 17" tall. Monitor tilt and swivel capability. Enclosed cable management. Grommet or desktop mounting. Clean appearance. In some applications the Monitor Arms may extend 12 or more inches into the worksurface. For additional information see page 825. HON 5-Year Limited Warranty.</p> <p>⚠ No specification needed.</p> <p>⚠ Cannot be used with Empower® height adjustable models.</p>	HBDMAUSB	41.9	2.6	\$441
	<p>Coordinate™ Mounted Desktop Riser</p> <p>NOTES: Does not include a monitor arm and is suitable for laptops and/or monitors on their original stands.</p> <p>⚠ No specification needed.</p>	HS1100	60.0 Ⓞ	3.2	\$664
	<p>Coordinate™ Mounted Desktop Riser with Single Monitor Arm</p> <p>NOTES: Includes a monitor arm for a single monitor.</p> <p>⚠ No specification needed.</p>	HS1101	62.0 Ⓞ	3.2	\$777
	<p>Coordinate™ Mounted Desktop Riser with Dual Monitor Arm</p> <p>NOTES: Includes a monitor arm for dual monitors.</p> <p>⚠ No specification needed.</p>	HS1102	63.0 Ⓞ	3.2	\$883

NOTES FOR HS1100, HS1101, HS1102:

- These products are designed to allow the user to transition from seating position to standing position throughout the workday.
- Gas-assist lever-operated mechanism with positive stop.
- Clamp mount compatible with worksurfaces depths of 20"-30". 20" is for systems only.
- Clamp requires 3.5" of clearance along back edge of worksurface.
- Black seamless worksurfaces.
- Silver powder coated metal components.
- Lowers below worksurface level on 24" and 30"D worksurfaces.
- All models contain a large primary worksurface and a smaller keyboard / mouse surface.
- Beveled edges for sleek appearance and comfort while typing.
- Monitor arms include height, width, and swivel adjustment.
- For additional information see page 838.

- Not for use under overhead storage, with flush mounted modesty panels, or worksurfaces thinner than 1".
- ⚠ Not recommended for use on mobile (castered) worksurfaces.

MOUNTING AND COMPATIBILITY FOR HS1100, HS1101, HS1102:

- This product is intended to be installed on commercial-grade worksurfaces in good condition.
- Compatible with freestanding worksurfaces 24"-30"D or panel-supported worksurfaces 24"-30"D.
- Not for use on mobile worksurfaces.

Clamp Mount

Use when 3.5" minimum overhang is available

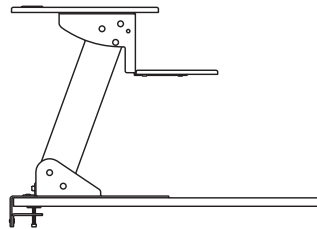

Screw Mount

Use when no overhang is available. Worksurface must be minimum 1" thick.

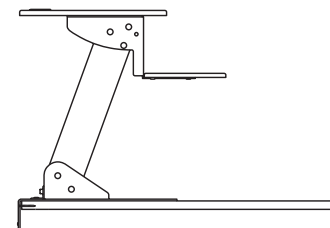

HOW TO SPECIFY

Select Model Number



Select Finish

BLK Black
WHT White

HBXRISER.

BLK

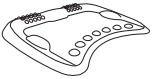
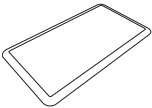
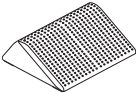

	DESCRIPTION	MODEL	SHIP WEIGHT	CUBE	LIST PRICE
	Rectangle Wobble Board — Anti-Fatigue Mat 18"D x 3"H x 22¼"W ⓘ Available in Black (T) finish ONLY. Recommended weight capacity not to exceed 250 pounds. HON 5-Year Limited Warranty. SPECIFYING EXAMPLE: HVL981.T	HVL981	10.0 Ⓔ	0.9	\$120
	Round Wobble Board — Anti-Fatigue Mat 18½"D x 2⅝"H x 18½"W ⓘ Available in Black (T) finish ONLY. Recommended weight capacity not to exceed 250 pounds. HON 5-Year Limited Warranty. SPECIFYING EXAMPLE: HVL982.T	HVL982	5.8 Ⓔ	0.6	\$102
	Ergonomic Anti-Fatigue Mat 25"D x 2¾"H x 29⅞"W ⓘ Available in Black ONLY. No specification needed. SPECIFYING EXAMPLE: HBEAFM1	HBEAFM1	7.0	1.4	\$219
	Rectangle Anti-Fatigue Mat 20"D x ¾"H x 36"W ⓘ Available in Black ONLY. No specification needed. SPECIFYING EXAMPLE: HBAFM2036	HBAFM2036	5.4	0.4	\$100
	Footrest — Anti-Slip Cover 13¾"D x 5½"H x 16"W ⓘ Available in Black (T) finish ONLY. Recommended weight capacity not to exceed 250 pounds. HON 5-Year Limited Warranty. SPECIFYING EXAMPLE: HVL991.T	HVL991	7.0 Ⓔ	0.9	\$82

HOW TO SPECIFY

<p>Select Model Number</p> <p>H V L 9 8 1 . T</p>	<p>Select Finish</p> <p>T Black</p>
---	-------------------------------------



Versé® Panels shown with SmartLink® Value Mobile Storage, Between™ Multi-Purpose Table, Motivate® Stacking Chair, and Hand Sanitizer Station.

VERSÉ®

Create more personal space in open areas with the Versé panel system. Easily connected and endlessly reconfigurable, Versé panels can maintain sightlines or maximize privacy, and keep frequently used items conveniently within reach. It's the smart long-term investment to support short-term work environments that are constantly changing.



FEATURES

- A variety of Versé panel widths and heights easily connect to one another to form workstations or offer privacy as space dividers. Available in sizes ranging from 24"-72"W and 42"-72"H.
- Steel hanging shelf hangs off the top of a Versé panel.
- Choose from three paint options to customize your office space.

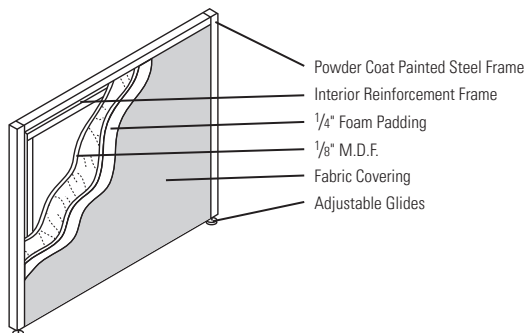
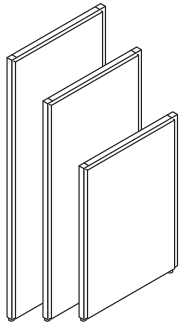
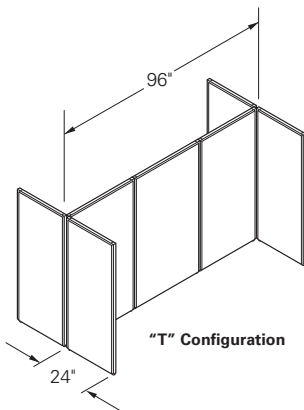
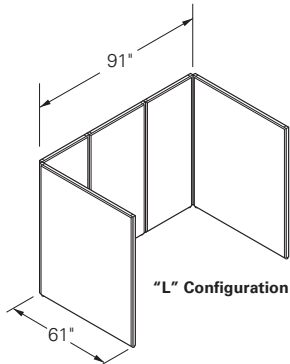

FEATURES

Panels

- Use Versé as a privacy panel (stand-alone) to create space division.

QuickConnect

(See page 608 for more details on this hardware.)

- Our QuickConnect connectors allow for easy installation. Simply snap on the connectors at the top and bottom of the panel and slide the panels together. There are only two connectors to specify for almost all configurations.

Storage

- Shelving capabilities. Each shelf width must match width of panel.

PANEL DIMENSIONS AND GROWTH ALLOWANCES

- All panel runs must be supported at each end of the panel run and supported at least every 8' within the panel run (maximum of 8' between supports).
- Support can be in the form of an adjustable wall bracket or return panel at 90° to the run.
- When using an "L" configuration, the return panel must measure at least 60% (minimum 36") of the unsupported run.
- When using a "T" configuration, each return panel must measure at least 20% of the unsupported run.
- Return panels can be no more than 24" lower than the panel height in the unsupported run.
- When used in conjunction with hanging shelves, panel width must match width of shelf.

VERSÉ PANELS

Includes

- Adjustable glides with all panels.

What Do I Need?

- QuickConnect Connectors.

Special Notes

- Versé panels feature a soft, padded look.
- Panels packed two per carton when possible.

VERSÉ® Panel System

Connection Type	Connectors Needed
Straight	1 pair – 180°
2-way (L)	1 pair – 90°
3-way (T)	2 pair – 90°
4-way (X)	3 pair – 90°

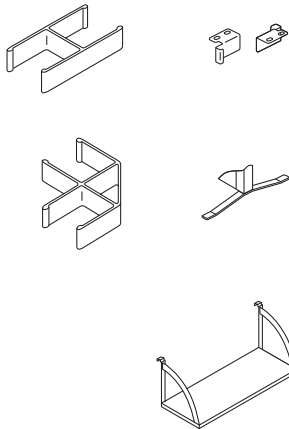

CONNECTING HARDWARE

Versé QuickConnect User Instructions

- Versé QuickConnect is easy to install. Simply snap on the connectors at the top and bottom of the panel and slide the panels together. There are only two connectors to specify for almost all configurations, including multi-height connections.
- 180° Straight Connector – use when connecting two panels together for a straight connection or for multi-height straight connections.
- 90° Corner Connector – use for 2-way, 3-way and 4-way corner connections. Only one pair is needed per corner connection or for multi-height corner connections.

HARDWARE

Special Notes

- Connectors add to the overall dimensions of the panel installation.
- These connector dimensions are important when space planning and sizing your panel layout.
- All hardware items may ship by a parcel service.
- Use HBV-PBS bracket with freestanding furniture for optimal workstation rigidity.

SHELVES

- Steel shelves are 14½" high.
- End brackets included.
- Must match panel width.
- Easy assembly; no tools required.

PANEL FABRIC & PAINT ORDERING CODES

PRICE CODE A	
CENTURION*	CU
◆ Apricot	CU47
◆ Bark	CU25
◆ Black	CU10
◆ Espresso	CU49
◆ Fog	CU03
◆ Frost	CU22
◆ Goldenrod	CU27
◆ Indigo	CU06
◆ Iris	CU50
◆ Iron Ore	CU19
◆ Jade	CU83
◆ Marsala	CU63
◆ Morel	CU24
◆ Navy	CU98
◆ Peacock	CU97
◆ Pear	CU84
◆ Ruby	CU67
◆ Sapphire	CU09

PRICE CODE A <i>continued</i>	
CONTOURETT POLYURETHANE*	VUR
◆ Baltic	VUR94
◆ Beach	VUR23
◆ Black	VUR10
◆ Bordeaux	VUR63
◆ Buff	VUR22
◆ Cloud	VUR18
◆ Coffee Bean	VUR49
◆ Crater	VUR51
◆ Flame	VUR62
◆ Graphite	VUR19
◆ Iron	VUR20
◆ Luggage	VUR26
◆ Marine	VUR92
◆ Navy	VUR95
◆ Nimbus	VUR93
◆ Ocean	VUR96
◆ Pumpkin	VUR42

PRICE CODE A <i>continued</i>	
CONTOURETT POLYURETHANE*	VUR
◆ Quarry	VUR24
◆ Red	VUR64
◆ Safari	VUR27
◆ Sage	VUR82
◆ Steel	VUR21
◆ Storm	VUR17
◆ Taupe	VUR28
◆ Trunk	VUR50
JAX*	JAX
◆ Blue	JAX05
◆ Graphite	JAX01
◆ Grey	JAX02
◆ Lead	JAX03
◆ Navy	JAX06
◆ Succulent	JAX07
◆ Taupe	JAX04

PRICE CODE A <i>continued</i>	
SEAWAY	2310
◆ Grey	2310GRE

PAINTS ORDERING CODES (Panel, T-base, Shelf and Connectors)	
Black	P
Light Gray	Q
Putty	L

* Centurion, Contourett, and Jax fabrics are only able to exceed 54" in one direction (vertically or horizontally), not both directions.

! To clean Versé Panels with Contourett use a 1:5 diluted bleach and water mixture or Virex II 256. Leave cleaning solution on for at least 30 seconds but no longer than two minutes. Thoroughly remove the solution from the surface with a clean cloth and warm water. May cause discoloration if left on the surface longer than the suggested time or not removed after sanitizing.

◆◆◆ For lead time information see page 19.

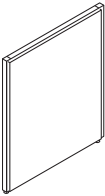
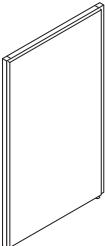
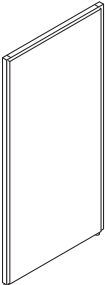
	DESCRIPTION	MODEL	SHIP WEIGHT	CUBE	LIST PRICE
	42" H Panel				
	42" H x 24" W	HBV-P4224	18	1.8	\$301
	42" H x 30" W	HBV-P4230	22	2.2	\$311
	42" H x 36" W	HBV-P4236	24	2.7	\$315
	42" H x 42" W	HBV-P4242	33	3.1	\$318
	42" H x 48" W	HBV-P4248	34	3.6	\$333
	42" H x 60" W	HBV-P4260	36	4.4	\$359
	42" H x 72" W	HBV-P4272	48	5.3	\$410
NOTES: All panels include adjustable glides.					
	60" H Panel				
	60" H x 24" W	HBV-P6024	30	2.5	\$335
	60" H x 30" W	HBV-P6030	33	3.2	\$346
	60" H x 36" W	HBV-P6036	35	3.8	\$347
	60" H x 42" W	HBV-P6042	37	4.4	\$364
	60" H x 48" W	HBV-P6048	42	5.0	\$370
	60" H x 60" W	HBV-P6060	54	6.4	\$386
	60" H x 72" W	HBV-P6072	60	7.5	\$452
NOTES: All panels include adjustable glides.					
	72" H Panel				
	72" H x 24" W	HBV-P7224	39	3.0	\$376
	72" H x 30" W	HBV-P7230	40	3.8	\$384
	72" H x 36" W	HBV-P7236	44	4.5	\$404
	72" H x 42" W	HBV-P7242	46	5.2	\$422
	72" H x 48" W	HBV-P7248	50	6.0	\$432
	72" H x 60" W	HBV-P7260	62	7.5	\$477
NOTES: All panels include adjustable glides.					

NOTES:

- **HON 5-Year Limited Warranty.**
- Panels offer privacy as room dividers or in desk-wrap applications.
- Panels feature 1" powder coat painted steel frame construction with interior reinforcement, 1/4" foam padding and 1/8" M.D.F.
- All panels include adjustable glides.
- To free-stand a single Versé panel or to stabilize the end of a panel run, order T-base stabilizing foot shown on page 608.
- See page 606 for available fabrics and finishes.

HOW TO SPECIFY











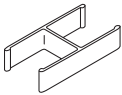

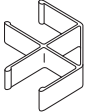



<p>Select Model Number</p> <p>HBV - P 4 2 2 4</p>	<p>Select Upholstery</p> <p>See page 606</p> <p>2 3 1 0 G R E</p>	<p>Select Trim Color</p> <p>P Black Q Light Gray L Putty</p> <p>See page 606</p> <p>P</p>
--	--	--

VERSÉ® Panel System

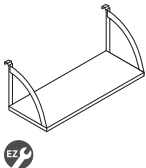
OPEN MARKET

Icon Legend on page 19

WORKSTATIONS

	DESCRIPTION	MODEL	SHIP WEIGHT	CUBE	LIST PRICE
	180° QuickConnect Straight Panel Connector Pair NOTES: 180° connector to be used to connect two panels in a straight connection or for multi-height straight connections.	HBV-QC180	0.1 	0.3	\$24
	90° QuickConnect Panel Connector Pair NOTES: 90° connector to be used for 2-way, 3-way or 4-way corner connections, or for multi-height connections.	HBV-QC90	0.1 	0.3	\$24
	Wall Bracket	HBV-PWB1	0.2 	0.3	\$51
	Panel-to-Worksurface Bracket Pair	HBV-PBS	0.3 	0.3	\$44
	T-Base Stabilizing Foot 18¾" long NOTES: Adds 1¼" to the height of the panel.	HBV-TBASE	6.0 	0.3	\$47
	Hanging Shelves 24"W x 12¾"D 30"W x 12¾"D 36"W x 12¾"D 42"W x 12¾"D 48"W x 12¾"D 60"W x 12¾"D NOTES: Shelves hang over the top of panels. Supporting panel must match the width of the shelf.	HBV-VSH24 HBV-VSH30 HBV-VSH36 HBV-VSH42 HBV-VSH48 HBV-VSH60	9.0  10.0  12.0  13.0  14.0  19.0 	1.2 1.5 1.8 2.0 2.3 2.9	\$192 \$213 \$234 \$251 \$286 \$327

NOTES:

- HON 5-Year Limited Warranty.
- T-base stabilizing foot optional.
- Extruded aluminum connectors are sold in pairs and are used at top and bottom of panels.
- Shelves hang over the top of panels; the supporting panel must match the width of the shelf.
- Shelves feature steel construction with powder coat paint finish.
- Shelves ship easy to assemble - no tools required.
- See page 606 for available fabrics and finishes.

HOW TO SPECIFY

<p>Select Model Number</p>	<p>Select Trim Color</p> <p>See page 606</p>
<p>HBV-QC180</p>	<p>P</p>

OVERVIEW OF PERSONAL STORAGE AND PEDESTALS

LATERAL FILES

Advantages:

a) The most efficient means of conventional filing; b) Ideal for active filing in workstations, where higher volume capacity is necessary and retrieval is frequent

Considerations:

2-drawer steel lateral files fit under standard-height worksurfaces when using panel systems.

VERTICAL FILES

Advantages:

a) Economical; b) The most widely used filing method; c) requires minimal floor space

Considerations:

Vertical files are best suited for long-term storage, where retrieval is less frequent. For larger banks of files, lateral files are more space-efficient than vertical files.

BOOKCASES

Advantages:

a) These units are ideal for binders, reference books or other items; b) Available with your choice of fixed or movable shelves

Considerations:

If working with panel systems, it is more attractive to specify units that are lower than the panel height.

FILING TECHNIQUES

Type	Standing Files	Hanging Files
Advantages	Inexpensive. Uses existing file folders.	Easier organization and identification of the file folders. Files viewed from top. Remaining files hold their place when folders are removed. Easier to re-stock.
Requirements	Follower block or Dividers	Hangrails or high-drawer sides
Can be used in	<ul style="list-style-type: none"> Vertical files (front-to-back only) Lateral files (side-to-side only in drawers) Shelf files (side-to-side only) 	<ul style="list-style-type: none"> Vertical files (front-to-back only) Lateral files (front-to-back or side-to-side in drawers)

Contain®/Flagship®/Brigade® Series Pedestals Utilization with 38000 Series and 66000 Series.

Pedestal Depths	Abound® and Accelerate® Panel-Hung Worksurfaces			66000 StationMaster		38000 Series Modular Desks		
	18" Deep	24" Deep	30" Deep	24" Deep	29½" Deep	24" Deep	30" Deep	36" Deep
16¾" Deep	•	•	•	•	•	•	•	•
22⅞" Deep		•	•		•	•*	•	•
28⅞" Deep			•				•	•

* Cannot attach 22⅞"D Hanging Pedestal.

WORKING WITH STORAGE PEDESTALS

Storage Pedestals are available in 5 styles:

- Box/File Mobile.....(Model Nos. beginning with HSPM)
- Freestanding(Model Nos. beginning with HSPF)
- Hanging(Model Nos. beginning with HSPH)
- Worksurface Supporting**(Model Nos. beginning with HSPS)
- Under Worksurface Mobile.....(Model Nos. beginning with HSPM)

Worksurface height supporting pedestals have a taller base plate, resulting in a taller overall cabinet height. Consideration must be made to ensure that units align visually with each other. The accompanying chart will help you select the correct pedestal for your application.

Pedestal Models (Nos. begin with)	Style	Overall Height	Base Height	Spacer Required Below Worksurface
HSPM or H15	Box/File mobile	22⅞"	N/A	N/A
HSPF	Freestanding	28"	3½"	NO
HSPH or H14	Hanging	19½"	N/A	N/A
HSPS or H19 or H36	Worksurface supporting**	28"	3⅞"	NO
HSPM or H18 or H33	Under Worksurface mobile	28"	3⅞"	NO

** Units will support conventional 29½"H worksurfaces, WITHOUT SPACERS.

LATERAL FILING OPTIONS

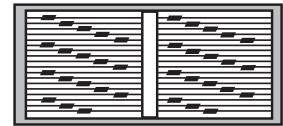

Front-to-back filing:

30" wide files*: 30½" of filing with letter/letter rows.

36" wide files*: 30½" of filing with letter/letter, legal/legal, or letter/legal rows.

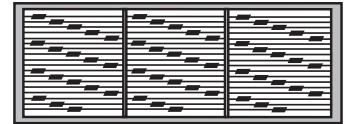

42" wide files**: 45¾" of filing with 3 rows letter or 30½" of 2 rows legal, or 2 standard printout rows.

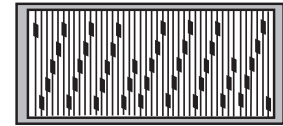

Side-to-side filing:

30" wide files: 27" of filing with letter or legal.

36" wide files: 33" of filing with letter or legal.

42" wide files: 39" of filing with letter or legal.

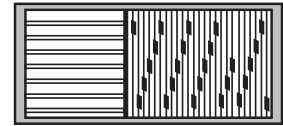

Combination filing:

(front-to-back with side-to-side in one drawer)

30" wide files: not recommended.

36" wide files: 15¼" of front-to-back filing and 20¼" of side-to-side legal filing.

42" wide files: 15¼" of front-to-back filing and 26¼" of side-to-side legal filing.

* Requires H919491 optional hangrails.

** Requires H919492 optional hangrails.

HON LATERAL FILES AT A GLANCE

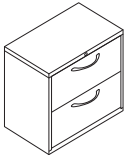

Flagship®

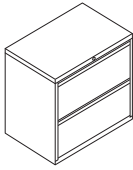

**Brigade®
Model H872L**

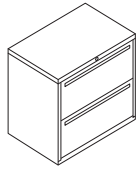

**Brigade®
Model H772L**

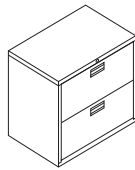

**Brigade®
Model H672L**



400 Series

Flagship Series lateral files are 18"D.
Brigade® 800, 700, 600 and 500 Series lateral files are all 18"D.

STORAGE

Series	Widths Available	Heights Available	Suspension Style	Usage	Pull	Safety Interlock	Lock	Features
Flagship, Brigade® 800, 700, 600	30" 36" 42"	2 dwr 3 dwr 4 dwr 5 dwr	Heavy-Duty ball-bearing (telescoping)	Intensive	Flagship Series 3 Pulls available. See page 612. Brigade® 800 Series Full-width radius designer style with magnetic label holders Brigade® 700 Series Full-width designer style with magnetic label holders Brigade® 600 Series Anodized Aluminum with label magnetic holder	Positive Mechanical	Core removable	<ul style="list-style-type: none"> • 4 leveling glides • 2 hangrails per drawer • Rack resistant case reinforcement
400	30" 36"	2 dwr 4 dwr	Ball-bearing	Moderate	Color-matched polymer Monochromatic drawer pulls	Positive Mechanical	Core removable	<ul style="list-style-type: none"> • 2 leveling glides

All products meet or exceed ANSI/BIFMA and ISTA performance standards.

HON VERTICAL FILES AT A GLANCE

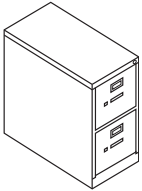

Model H212

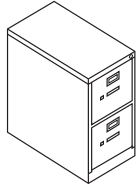

Model H312



Model H512

Vertical files listed below meet or exceed ANSI/BIFMA and ISTA performance standards. They are available in 15"W letter and 18¼"W legal widths.

Series	Depth	Heights Available	Suspension Style	Lock	Accepts Hanging Files	Features
210 Series	28½"	2 dwr 4 dwr 5 dwr	Three-part telescoping, ball-bearing steel suspension	INCLUDED core removable	YES (Hangrails not required)	Spring-loaded follower block
310 Series	26½"	2 dwr 4 dwr 5 dwr	Three-part telescoping, ball-bearing steel suspension	INCLUDED core removable	YES (Hangrails not required)	Spring-loaded follower block
510 Series	25"	2 dwr 4 dwr	Three-part telescoping, ball-bearing steel suspension	INCLUDED core removable	YES (Hangrails not required)	Adjustable wire follower

STORAGE AND FILES ORDERING INFORMATION

STORAGE

CONTAIN® PRODUCT

L1 LAMINATES CODES

Woodgrain

- ◆ Bourbon Cherry H
- ◆ Cognac COGN
- ◆ Florence Walnut LFW1
- ◆ Harvest C
- ◆ Kingswood Walnut LK11
- ◆ Mahogany N
- ◆ Mocha MOCH
- ◆ Natural Maple D
- ◆ Pinnacle PINC
- ◆ Shaker Cherry F

L2 LAMINATES CODES

Woodgrain

- ◆ Lowell Ash LLA1
- ◆ Natural Recon LNR1
- ◆ Phantom Ecru LPE1
- ◆ Portico Teak LPT1
- ◆ Skyline Walnut LSW1

OPTIONAL LAMINATE TOPS FOR LATERAL FILES AND CONTAIN® CREDENZAS

L1 LAMINATES CODES

Woodgrain

- ◆ Bourbon Cherry H
- ◆ Cognac COGN
- ◆ Florence Walnut LFW1
- ◆ Harvest C
- ◆ Kingswood Walnut LK11
- ◆ Mahogany N
- ◆ Mocha MOCH
- ◆ Natural Maple D
- ◆ Pinnacle PINC
- ◆ Shaker Cherry F
- ◆ Sterling Ash LSA1

Solid

- ◆ Charcoal S
- ◆ Designer White LDW1
- ◆ Loft LOFT

Patterned

- ◆ Sheer Mesh* A5
- ◆ Silver Mesh* B9
- ◆ Steel Mesh* A9
- ◆ Canyon Zephyr K9
- ◆ Desert Zephyr K8
- ◆ Shadow Zephyr K1
- ◆ Gray* G2
- ◆ White* G1

L2 LAMINATES CODES

Woodgrain

- ◆ Lowell Ash LLA1
- ◆ Natural Recon LNR1
- ◆ Phantom Ecru LPE1
- ◆ Portico Teak LPT1
- ◆ Skyline Walnut LSW1

OPTIONAL LAMINATE TOPS FOR STEEL BOOKCASES

L1 LAMINATES CODES

Woodgrain

- ◆ Bourbon Cherry H
- ◆ Florence Walnut LFW1
- ◆ Harvest C
- ◆ Kingswood Walnut LK11
- ◆ Mahogany N
- ◆ Natural Maple D
- ◆ Shaker Cherry F
- ◆ Sterling Ash LSA1

Solid

- ◆ Charcoal S
- ◆ Designer White LDW1

Patterned

- ◆ Sheer Mesh* A5
- ◆ Silver Mesh* B9
- ◆ Steel Mesh* A9
- ◆ Canyon Zephyr K9
- ◆ Desert Zephyr K8
- ◆ Shadow Zephyr K1
- ◆ Gray* G2
- ◆ White* G1

1870 SERIES BOOKCASES

L1 LAMINATES CODES

Woodgrain

- ◆ Cognac COGN
- ◆ Harvest C
- ◆ Mahogany N

FLAGSHIP®, CONTAIN® PRODUCT, BRIGADE PEDESTALS, BRIGADE 800, 700, 600 LATERAL FILES, 210, 310/H320, AND 510 SERIES VERTICAL FILES, BRIGADE STORAGE CABINETS, BRIGADE STEEL BOOKCASES

PAINTS CODES

P1

- ◆ Black P
- ◆ Brownstone P7D
- ◆ Charcoal S
- ◆ Designer White PJW
- ◆ Fossil P28
- ◆ Greige T5
- ◆ Light Gray Q
- ◆ Loft LOFT
- ◆ Muslin T3
- ◆ Putty L
- ◆ Shadow* SHDW
- ◆ Titanium P8T

P2

- ◆ Champagne Metallic T4
- ◆ Platinum Metallic T1
- ◆ Silver** PR6
- ◆ Solar Black** P8X

400 SERIES LATERAL, FLAMESAFE FILES

PAINTS CODES

P1

- ◆ Black P
- ◆ Light Gray Q
- ◆ Loft LOFT
- ◆ Putty L

PULL OPTIONS FOR CONTAIN® AND FLAGSHIP® STORAGE

Suffix "A"



Satin Chrome Arch Pull

Suffix "N"



Full Face Integral Drawer Pull

Suffix "R"



Full Radius Drawer Pull

NOTES: Arch pulls available in Satin Chrome only.

* Laminate colors will have the following pre-set edgeband colors:

** Only available on Flagship® Pedestals and Contain®.

Laminate	Edge
Sheer Mesh	Muslin
Silver Mesh	Loft
Steel Mesh	Charcoal
Gray	Charcoal
White	Charcoal

Edgeband matches top except as noted.

For Champagne Metallic Paint, Muslin is the suggested edgeband color. When Champagne Metallic Paint is selected, pulls are standard in Muslin.

- The HON Company has elected to discontinue the HON Choice paint program, as of 12/31/2018, and roll it into our standard specials process.
- A special request will need to be submitted to receive pricing and order information.

◆◆◆ For lead time information see page 19.

* De-emphasized

BRIGADE®



Brigade® Storage.

STORAGE

BRIGADE®

You don't need an army to bring order to your office. Just a brigade. Sturdily built to rigorous specifications, our Brigade storage is ready to serve any organization needing top-quality storage. With welded construction and features like heavy-duty steel ball-bearing suspensions, it outlasts and outperforms most build-it-yourself options. Brigade was built to soldier on.



FEATURES

- Clean, straightforward design complements and blends in with any workspace.
- Optional laminate tops provide extra surface area for technology tools, collating or stand-up work.
- With a combination of reasonable pricing and high quality, Brigade is a value that's hard to beat.
- Heavy-duty Steel ball-bearing drawer suspensions operate easily and quietly.
- Mechanical interlock prevents more than one drawer from being opened at a time, for stability.

BRIGADE® ORDERING INFORMATION

STORAGE

BRIGADE PRODUCTS

PAINTS CODES

P1

- ◆ Black P
- ◆ Brownstone P7D
- ◆ Charcoal S
- ◆ Designer White PJW
- ◆ Fossil P28
- ◆ Greige T5
- ◆ Light Gray Q
- ◆ Loft LOFT
- ◆ Muslin T3
- ◆ Putty L
- ◆ Shadow * SHDW
- ◆ Titanium P8T

P2

- ◆ Champagne Metallic T4
- ◆ Platinum Metallic T1

OPTIONAL LAMINATE TOPS FOR LATERAL FILES AND CONTAIN® CREDENZAS

L1 LAMINATES CODES

Woodgrain

- ◆ Bourbon Cherry H
- ◆ Cognac COGN
- ◆ Florence Walnut LFW1
- ◆ Harvest C
- ◆ Kingswood Walnut LK11
- ◆ Mahogany N
- ◆ Mocha MOCH
- ◆ Natural Maple D
- ◆ Pinnacle PINC
- ◆ Shaker Cherry F
- ◆ Sterling Ash LSA1

Solid

- ◆ Charcoal S
- ◆ Designer White LDW1
- ◆ Loft LOFT

Patterned

- ◆ Sheer Mesh* A5
- ◆ Silver Mesh* B9
- ◆ Steel Mesh* A9
- ◆ Canyon Zephyr K9
- ◆ Desert Zephyr K8
- ◆ Shadow Zephyr K1
- ◆ Gray* G2
- ◆ White* G1

L2 LAMINATES CODES

Woodgrain

- ◆ Lowell Ash LLA1
- ◆ Natural Recon LNRI
- ◆ Phantom Ecu LPE1
- ◆ Portico Teak LPT1
- ◆ Skyline Walnut LSW1

For Champagne Metallic Paint, Muslin is the suggested edgeband color.

- The HON Company has elected to discontinue the HON Choice paint program, as of 12/31/2018, and roll it into our standard specials process.
- A special request will need to be submitted to receive pricing and order information.

* Laminate colors will have the following pre-set edgeband colors:

Laminate	Edge
Sheer Mesh	Muslin
Silver Mesh	Loft
Steel Mesh	Charcoal
Gray	Charcoal
White	Charcoal

Edgeband matches top except as noted.

◆◆◆ For lead time information see page 19.

* De-emphasized



Icon Legend on page 19

BRIGADE® Standard Height Pedestals

	DESCRIPTION	MODEL	SHIP WEIGHT	CUBE	LIST PRICE BY PAINT GRADE		
					P1	P2	P3
	Standard Height Mobile Pedestals — Box/Box/File						
	15"W x 19 7/8"D x 28"H	H33720(?)	73	6.6	\$591	\$619	\$647
	15"W x 22 7/8"D x 28"H	H33723(?)	77	7.5	\$610	\$638	\$666
	Standard Height Mobile Pedestals — File/File						
	15"W x 19 7/8"D x 28"H	H33820(?)	73	6.6	\$585	\$613	\$641
	15"W x 22 7/8"D x 28"H	H33823(?)	77	7.5	\$604	\$632	\$660
	Standard Height Freestanding Support Pedestals — Box/Box/File						
	15"W x 19 7/8"D x 28"H	H36720(?)	61	6.6	\$581	\$609	\$637
	15"W x 22 7/8"D x 28"H	H36723(?)	83	7.5	\$602	\$630	\$658
	Standard Height Freestanding Support Pedestals — File/File						
	15"W x 19 7/8"D x 28"H	H36820(?)	61	6.6	\$576	\$604	\$632
	15"W x 22 7/8"D x 28"H	H36823(?)	83	7.5	\$596	\$624	\$652

STORAGE

NOTES:

- 28"H fits under all HON worksurfaces and desk shells.
 - Pencil tray standard in top box drawer.
 - One box divider standard in each box drawer.
 - One crossrail standard in each file drawer.
 - Ball-bearing suspension on file and box drawers with 90% extension.
 - File drawers have high sides for filing front-to-back.
 - See pages 679-680 for accessories and pedestal utilization information.
 - Equipped with HON "One Key" interchangeable core removable locks.
 - Front casters are fixed, rear casters swivel on mobile pedestals.
 - "N" Pull matches Brigade 700 Series lateral file pull.
 - "R" pull matches Brigade 800 Series Lateral Pull.
 - See pages 679-680 for Pedestal Accessories. Additional Flagship pedestal models on pages 652-653.
- ! Freestanding support pedestals that are not positioned and attached under a worksurface, require a counterweight kit found on page 679.

HOW TO SPECIFY

<p>Select Model Number</p> <p>Select the Pull</p> <p>N Full Face Integral R Full Radius</p> <p>H 3 3 7 2 0 R</p>	<p>Select Lock Option</p> <p>L Lock</p> <p>L</p>	<p>Select Paint Color</p> <p>See page 614</p> <p>P</p>
---	--	--

BRIGADE® 800 SERIES Lateral Files w/Drawers

GSA SIN 33721



Icon Legend on page 19

STORAGE



DESCRIPTION

Lateral File — 2 Drawer

30"W x 18"D x 28"H
36"W x 18"D x 28"H
42"W x 18"D x 28"H

MODEL

SHIP WEIGHT

CUBE

LIST PRICE BY PAINT GRADE

P1

P2

P3

H872	121	12.2	\$789	\$822	\$856
H882	131	14.3	\$882	\$915	\$949
H892	141	16.7	\$1020	\$1053	\$1087



Lateral File — 3 Drawer

30"W x 18"D x 39¹/₈"H
36"W x 18"D x 39¹/₈"H
42"W x 18"D x 39¹/₈"H

H873	158	16.4	\$1121	\$1154	\$1188
H883	175	19.1	\$1250	\$1283	\$1317
H893	190	22.4	\$1450	\$1483	\$1517

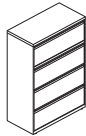

Lateral File — 4 Drawer

30"W x 18"D x 52¹/₂"H
36"W x 18"D x 52¹/₂"H
42"W x 18"D x 52¹/₂"H

H874	197	21.4	\$1359	\$1426	\$1492
H884	217	25.1	\$1541	\$1608	\$1674
H894	232	29.4	\$1769	\$1836	\$1902

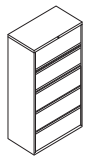

Lateral File — 5 Drawer

30"W x 18"D x 64¹/₄"H
36"W x 18"D x 64¹/₄"H
42"W x 18"D x 64¹/₄"H

H875	199	25.8	\$1805	\$1872	\$1938
H885	215	30.1	\$2032	\$2099	\$2165
H895	244	35.3	\$2347	\$2414	\$2480

NOTES: Top drawer is a roll-out shelf.

NOTES:

- 30", 36" & 42" case widths with drawers, 18" case depth.
- Flush top and sides.
- Reinforced case construction.
- Four adjustable leveling glides.
- Full-width radius designer style pull.
- Features drawer extension restraint; mechanical interlock inhibits the extension of more than one drawer at a time.
- Three-part, telescoping, steel ball-bearing suspension.
- Two adjustable hangrails per drawer for side-to-side filing.
- Counterweight included where applicable to meet ANSI/BIFMA stability requirements.
- Lock mechanism secures both sides of drawer.
- Baked enamel finish over rust-inhibiting phosphate pre-treatment.
- Equipped with HON "One Key" interchangeable core removable locks.
- Optional laminate tops and accessories — see page 676.
- See page 676 for Lateral File Accessories.

! Keyed alike cores must be ordered separately — see page 853.

HOW TO SPECIFY

<p>Select Model Number</p> <p>H 8 7 2 .</p>	<p>Select Lock Option</p> <p>L Lock</p> <p>L .</p>	<p>Select Paint Color</p> <p>See page 614</p> <p>T 1</p>
--	---	---



Icon Legend on page 19

BRIGADE® 800 SERIES Lateral Files w/Storage

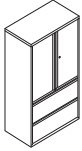

DESCRIPTION

Lateral File w/Storage — 2 Drawer

30"W x 18"D x 64¼"H
 36"W x 18"D x 64¼"H
 42"W x 18"D x 64¼"H

MODEL	SHIP WEIGHT	CUBE	LIST PRICE BY PAINT GRADE		
			P1	P2	P3
H875LS	174	27.5	\$1449	\$1516	\$1582
H885LS	210	32.9	\$1597	\$1664	\$1730
H895LS	228	38.0	\$1824	\$1891	\$1957

NOTES:

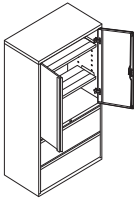

- 30", 36" & 42" case widths, 18" case depth.
- 46¼"H case - matches height of 800 Series 5 Drawer laterals.
- Bottom two openings are lateral drawers, remainder of case is storage shelves.
- Lateral file drawer features are same as 800 Series Laterals shown on previous page.
- Inside dimension of storage case is 36¼"H. Includes 2 adjustable shelves, adjustable in 2" increments. Bottom shelves accept two rows of 3-ring binders; top opening measures: 10¼".
- Storage case is standard with 2 hinged doors. Door pulls match lateral file drawer pulls.
- Equipped with HON "One Key" interchangeable core removable locks. Locks on storage case and lateral file are keyed alike. Lateral file drawers lock independently from storage case.
- Four adjustable leveling glides.
- See page 676 for Lateral File Accessories and page 621 for Wire Dividers.

STORAGE

HOW TO SPECIFY

<p>Select Model Number</p> <p>H 8 7 5 L S .</p>	<p>Select Lock Option</p> <p>L Lock</p> <p>L .</p>	<p>Select Paint Color</p> <p>See page 614</p> <p>T 1</p>
--	---	---

BRIGADE® 700 SERIES

Lateral Files w/Drawers

GSA SIN 33721



Icon Legend on page 19

STORAGE

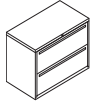

DESCRIPTION

Lateral File — 2 Drawer (locking)

30"W x 18"D x 28"H
36"W x 18"D x 28"H
42"W x 18"D x 28"H

MODEL	SHIP WEIGHT	CUBE	LIST PRICE BY PAINT GRADE		
			P1	P2	P3
H772	121	12.2	\$789	\$822	\$856
H782	131	14.3	\$882	\$915	\$949
H792	141	16.7	\$1020	\$1053	\$1087

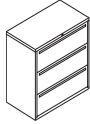

Lateral File — 3 Drawer (locking)

30"W x 18"D x 39¹/₈"H
36"W x 18"D x 39¹/₈"H
42"W x 18"D x 39¹/₈"H

H773	158	16.4	\$1121	\$1154	\$1188
H783	175	19.1	\$1250	\$1283	\$1317
H793	190	22.4	\$1450	\$1483	\$1517

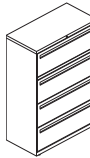

Lateral File — 4 Drawer (locking)

30"W x 18"D x 52¹/₂"H
36"W x 18"D x 52¹/₂"H
42"W x 18"D x 52¹/₂"H

H774	197	21.4	\$1359	\$1426	\$1492
H784	217	25.1	\$1541	\$1608	\$1674
H794	232	29.4	\$1769	\$1836	\$1902

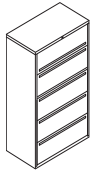

Lateral File — 5 Drawer (locking)

30"W x 18"D x 64¹/₄"H
36"W x 18"D x 64¹/₄"H
42"W x 18"D x 64¹/₄"H

H775	199	25.8	\$1805	\$1872	\$1938
H785	215	30.1	\$2032	\$2099	\$2165
H795	244	35.3	\$2347	\$2414	\$2480

NOTES: Top drawer is a roll-out shelf.

NOTES:

- 30", 36" & 42" case widths with drawers, 18" case depth.
- Flush top and sides.
- Reinforced case construction.
- Four adjustable leveling glides.
- Full-face integral drawer pulls.
- Features drawer extension restraint; mechanical interlock inhibits the extension of more than one drawer at a time.
- Three-part, telescoping, steel ball-bearing suspension.
- Two adjustable hangrails per drawer/rollout shelf for side-to-side filing.
- Counterweight included where applicable to meet ANSI/BIFMA stability requirements.
- Lock mechanism secures both sides of drawer.
- Baked enamel finish over rust-inhibiting phosphate pre-treatment.
- Optional laminate tops and accessories — see page 676.
- Equipped with HON "One Key" interchangeable core removable locks.
- See page 676 for Lateral File Accessories.

! Keyed alike cores must be ordered separately — see page 853.

HOW TO SPECIFY

<p>Select Model Number</p> <p>H 7 7 2 .</p>	<p>Select Lock Option</p> <p>L Lock</p> <p>L .</p>	<p>Select Paint Color</p> <p>See page 614</p> <p>T 1</p>
---	--	--



Icon Legend on page 19

BRIGADE® 700 SERIES Lateral Files w/Storage

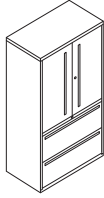

DESCRIPTION

Lateral File w/Storage — 2 Drawer
 30"W x 18"D x 64¼"H
 36"W x 18"D x 64¼"H
 42"W x 18"D x 64¼"H

MODEL	SHIP WEIGHT	CUBE	LIST PRICE BY PAINT GRADE		
			P1	P2	P3
H775LS	175	27.5	\$1449	\$1516	\$1582
H785LS	211	32.9	\$1597	\$1664	\$1730
H795LS	230	38.0	\$1824	\$1891	\$1957

NOTES:

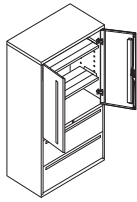

- 30", 36" & 42" case widths, 18" case depth.
- 64¼"H case - matches height of 700 Series 5 Drawer laterals.
- Bottom two openings are lateral drawers, remainder of case is storage shelves.
- Lateral file drawer features are same as 700 Series Laterals shown on previous page.
- Inside dimension of storage case is 36¼"H. Includes 2 adjustable shelves, adjustable in 2" increments. Bottom shelves accept two rows of 3-ring binders; top opening measures: 10¼".
- Storage case is standard with 2 hinged doors. Door pulls match lateral file drawer pulls.
- Equipped with HON "One Key" interchangeable core removable locks. Locks on storage case and lateral file are keyed alike. Lateral file drawers lock independently from storage case.
- Four adjustable leveling glides.
- See page 676 for Lateral File Accessories and page 621 for Wire Dividers.

STORAGE

HOW TO SPECIFY

<p>Select Model Number</p> <p>H 7 7 5 L S .</p>	<p>Select Lock Option</p> <p>L Lock</p> <p>L .</p>	<p>Select Paint Color</p> <p>See page 614</p> <p>T 1</p>
--	---	---

BRIGADE® 600 SERIES Lateral Files w/Drawers

GSA SIN 33721



Icon Legend on page 19

STORAGE

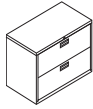

DESCRIPTION

Lateral File — 2 Drawer

30"W x 18"D x 28"H
36"W x 18"D x 28"H
42"W x 18"D x 28"H

MODEL	SHIP WEIGHT	CUBE	LIST PRICE BY PAINT GRADE		
			P1	P2	P3
H672	121	12.2	\$728	\$761	\$795
H682	131	14.3	\$783	\$816	\$850
H692	141	16.7	\$924	\$957	\$991



Lateral File — 3 Drawer

30"W x 18"D x 39½"H
36"W x 18"D x 39½"H
42"W x 18"D x 39½"H

H673	158	16.4	\$1000	\$1033	\$1067
H683	175	19.1	\$1094	\$1127	\$1161
H693	190	22.4	\$1285	\$1318	\$1352

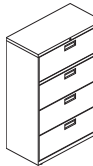

Lateral File — 4 Drawer

30"W x 18"D x 52½"H
36"W x 18"D x 52½"H
42"W x 18"D x 52½"H

H674	197	21.4	\$1242	\$1309	\$1375
H684	217	25.1	\$1358	\$1425	\$1491
H694	232	29.4	\$1610	\$1677	\$1743

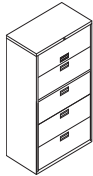

Lateral File — 5 Drawer

30"W x 18"D x 64¼"H
36"W x 18"D x 64¼"H
42"W x 18"D x 64¼"H

H675	199	25.8	\$1650	\$1717	\$1783
H685	215	30.1	\$1764	\$1831	\$1897
H695	244	35.3	\$2128	\$2195	\$2261

NOTES: Top drawer is a roll-out shelf.

NOTES:

- 30", 36" & 42" case widths with drawers, 18" case depth.
- Flush top and sides.
- Reinforced case construction.
- Four adjustable leveling glides.
- Features drawer extension restraint; mechanical interlock inhibits the extension of more than one drawer at a time.
- Three-part, telescoping, steel ball-bearing suspension.
- Two adjustable hangrails per drawer/roll-out shelf for side-to-side filing.
- Counterweight included where applicable to meet ANSI/BIFMA stability requirements.
- Lock mechanism secures both sides of drawer.
- Baked enamel finish over rust-inhibiting phosphate pre-treatment.
- Bright anodized aluminum recessed drawer pull.
- Equipped with HON "One Key" interchangeable core removable locks.
- Optional laminate tops and accessories — see page 676.
- See page 676 for Lateral File Accessories.

! Keyed alike cores must be ordered separately — see page 853.

HOW TO SPECIFY

Select Model Number <input type="text" value="H672"/>	Select Lock Option <input type="text" value="L"/>	Select Paint Color See page 614 <input type="text" value="T1"/>
---	---	--



Icon Legend on page 19

BRIGADE[®] Metal Dividers

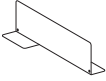
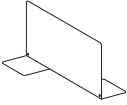
	DESCRIPTION	MODEL	SHIP WEIGHT	CUBE	LIST PRICE P1
	Metal Box Divider				
	10 pack	HSCABD10	7	0.7	\$167
	2 pack	HSCABD02	2	0.7	\$42
<p>! Metal dividers available in Black only. No need to specify.</p>					
	Metal File Divider				
	10 pack	HSCAFD10	12	0.7	\$199
	2 pack	HSCAFD02	3	0.7	\$52
<p>! Metal dividers available in Black only. No need to specify.</p>					

STORAGE

HOW TO SPECIFY

Select
Model Number

H S C A B D 1 0

BRIGADE® Steel Bookcases

GSA SIN 33721



Icon Legend on page 19

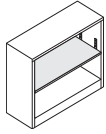

Shaded shelves
are adjustable.

DESCRIPTION

Steel Bookcase

34½"W x 12⅝"D x 29"H, 2-Shelf
34½"W x 12⅝"D x 41"H, 3-Shelf
34½"W x 12⅝"D x 59"H, 4-Shelf
34½"W x 12⅝"D x 71"H, 5-Shelf
34½"W x 12⅝"D x 81⅝"H, 6-Shelf

MODEL	SHIP WEIGHT	CUBE	LIST PRICE BY PAINT GRADE		
			P1	P2	P3
HS30ABC	44	9.6	\$252	\$285	\$319
HS42ABC	57	13.3	\$302	\$335	\$369
HS60ABC	77	18.9	\$451	\$518	\$584
HS72ABC	87	22.6	\$514	\$581	\$647
HS82ABC	97	27.5	\$744	\$811	\$877

Extra Shelf for all Models

NOTES: Edge is ¾" thick. Specify: Paint

HB9	7 Ⓞ	0.3	\$85	\$98	\$108
-----	-----	-----	------	------	-------

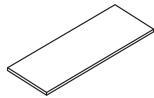

STORAGE

NOTES:

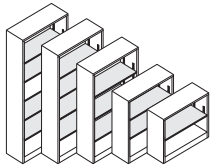

- Available in 2, 3, 4, 5, and 6 shelf models.
- Inside shelf depth is 12⅝".
- Bookcase shelves easily adjust in ½" increments (shaded shelves are adjustable).
- Optional laminate tops available.
- Baked enamel finish over rust-inhibiting phosphate pre-treatment.

HOW TO SPECIFY

Select Model Number

HS30ABC .

Select Paint Color

See page 614

P

DESCRIPTION

Laminate Top for all Models

NOTES: Specify: Laminate

MODEL	SHIP WEIGHT	CUBE	LIST PRICE
H511596	16 Ⓞ	0.7	\$256

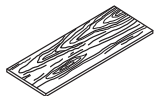

HOW TO SPECIFY

Select Model Number

H511596 .

Select Laminate

See page 614

N



Icon Legend on page 19

BRIGADE® Storage Cabinets

STORAGE

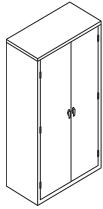

71³/₄" High

DESCRIPTION

Storage Cabinets

36"W x 18¹/₈"D x 72"H
36"W x 24¹/₈"D x 72"H

NOTES: Includes 5 adjustable shelves.

MODEL	SHIP WEIGHT	CUBE	LIST PRICE BY PAINT GRADE		
			P1	P2	P3
HSC1872	131	36.5	\$994	\$1061	\$1127
HSC2472	149	46.7	\$1247	\$1314	\$1380

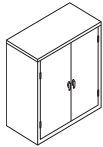

41³/₄" High

Storage Cabinet

36"W x 18¹/₈"D x 41³/₄"H

NOTES: Includes 2 adjustable shelves.

HSC1842	82	21.8	\$840	\$885	\$929
----------------	----	------	--------------	--------------	--------------

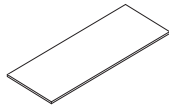

Additional Shelves

36"W x 18"D
36"W x 24"D

HAS18	6 Ⓢ	0.6	\$118	\$131	\$141
HAS24	8 Ⓢ	0.7	\$147	\$160	\$170

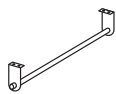

Conversion Kit

Hanging Bar and brackets to convert a Storage Cabinet into a Wardrobe Cabinet.

HWC72	5 Ⓢ	0.4	\$109		
--------------	------------	-----	--------------	--	--

NOTES: Necessary hardware included to screw into shelf.

❗ For use on 72"H HSC Model Storage Cabinets shown above, only.

❗ Anodized Aluminum finish only. No need to specify paint color.

SPECIFY: HWC72

NOTES:

- Product shipped fully assembled.
- All shelves are adjustable in 2" increments.
- Stretch-wrap cartoning.
- Flush top.
- Two adjustable leveling glides standard.
- Reinforced base.
- One locking handle, one fixed handle.
- Adjustable shelves.
- Doors have vertical stiffener standard.
- Positive door stops.
- Equipped with HON "One Key" interchangeable core removable locks.

❗ Keyed alike cores must be ordered separately – see page 853.

HOW TO SPECIFY

<p>Select Model Number</p> <p>H S C 2 4 7 2 .</p>	<p>Select Lock Option</p> <p>L Lock</p> <p>L .</p>	<p>Select Paint Color</p> <p>See page 614</p> <p>P</p>
--	---	---

CONTAIN®

STORAGE



Contain® Storage shown with Ignition® Task Chair and Ceres® Guest Seating.

⊗ Contain® Towers and Credenzas underwent a base model transition earlier this year and new models were introduced. For current models and pricing please reference the new Contain® Pricer here.

CONTAIN®

Harder-working storage. That's what you need. So we re-examined it from the inside out and developed our new Contain storage solutions. With a variety of shapes and sizes, functions and configurations, Contain can help you expand your capabilities for storage, efficiency and collaboration — and elevate your aesthetic too.



FEATURES

- Combine metal, laminate and color to create a unique and unified look for your office.
- All Contain models are available with a homey footed base or a kickplate for a more geometric look.
- Pair low credenzas and pedestals with seat cushions to turn any space into a collaborative hub.

CONTAIN® ORDERING INFORMATION

CONTAIN® PRODUCTS

PAINTS CODES

P1	
◆ Black	P
◆ Brownstone	P7D
◆ Charcoal	S
◆ Designer White	PJW
◆ Fossil	P28
◆ Greige	T5
◆ Light Gray	Q
◆ Loft	LOFT
◆ Muslin	T3
◆ Putty	L
◆ Shadow*	SHDW
◆ Titanium	P8T
P2	
◆ Champagne Metallic	T4
◆ Platinum Metallic	T1
◆ Silver	PR6
◆ Solar Black	P8X

CONTAIN® PRODUCTS

L1 LAMINATES CODES

Woodgrain	
◆ Bourbon Cherry	H
◆ Cognac	COGN
◆ Florence Walnut	LFW1
◆ Harvest	C
◆ Kingswood Walnut	LK11
◆ Mahogany	N
◆ Mocha	MOCH
◆ Natural Maple	D
◆ Pinnacle	PINC
◆ Shaker Cherry	F
L2 LAMINATES CODES	
Woodgrain	
◆ Lowell Ash	LLA1
◆ Natural Recon	LNRI
◆ Phantom Ecu	LPE1
◆ Portico Teak	LPT1
◆ Skyline Walnut	LSW1

OPTIONAL LAMINATE TOPS FOR LATERAL FILES AND CONTAIN® CREDENZAS

L1 LAMINATES CODES

Woodgrain	
◆ Bourbon Cherry	H
◆ Cognac	COGN
◆ Florence Walnut	LFW1
◆ Harvest	C
◆ Kingswood Walnut	LK11
◆ Mahogany	N
◆ Mocha	MOCH
◆ Natural Maple	D
◆ Pinnacle	PINC
◆ Shaker Cherry	F

Solid	
◆ Charcoal	S
◆ Designer White	LDW1
◆ Loft	LOFT

Patterned	
◆ Sheer Mesh*	A5
◆ Silver Mesh*	B9
◆ Steel Mesh*	A9
◆ Canyon Zephyr	K9
◆ Desert Zephyr	K8
◆ Shadow Zephyr	K1
◆ Gray*	G2
◆ White*	G1

L2 LAMINATES CODES

Woodgrain	
◆ Lowell Ash	LLA1
◆ Natural Recon	LNRI
◆ Phantom Ecu	LPE1
◆ Portico Teak	LPT1
◆ Skyline Walnut	LSW1

NOTES: L2 Upcharges are \$20 for credenzas, \$35 for towers, and \$10 for pedestals.

PULL OPTIONS FOR CONTAIN® AND FLAGSHIP® STORAGE

Suffix "A"



Satin Chrome Arch Pull

Suffix "N"



Full Face Integral Drawer Pull

Suffix "R"



Full Radius Drawer Pull

NOTES: Arch pulls available in Satin Chrome only.

* Laminate colors will have the following pre-set edgeband colors:

Laminate	Edge
Sheer Mesh	Muslin
Silver Mesh	Loft
Steel Mesh	Charcoal
Gray	Charcoal
White	Charcoal

Edgeband matches top except as noted.

For Champagne Metallic Paint, Muslin is the suggested edgeband color. When Champagne Metallic Paint is selected, pulls are standard in Muslin.

◆◆◆ For lead time information see page 19.

* De-emphasized

CONTAIN[®] Metal Storage

METAL CRENZAS WITH PANEL FRAMES

Guidelines for using Contain[®] Credenzas in place of standard panel systems configurations

Side-mounted Credenzas

Use 1 storage-to-panel bracket set.

The minimum credenza size is 22"H x 36"W x 18"D.

With a mid-run floor support, the maximum panel run is 144".

Without a mid-run panel attached floor support, the maximum panel run is 96".

Overheads and shelves cannot be used with 22"H side mounted credenzas.

Worksurfaces (if specified) must be mounted on the same side of the parent run as the credenzas.

Panel frame maximum height is 68".

Counterweight is required, if using unit with drawers.

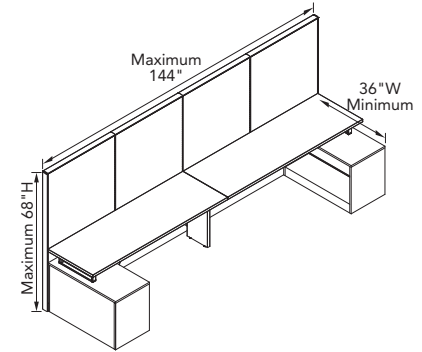

Back-mounted Credenzas — Modular

Use 2 storage-to-panel bracket sets per Credenza — 2 LH and 2 RH.

The minimum credenza size is 22"H x 36"W x 18"D.

The maximum panel run between back-mounted credenzas is 60".

Overheads and shelves cannot be used with 22"H back mounted credenzas.

Worksurfaces (if specified) must be mounted on the same side of the parent run as the credenzas.

Panel frame maximum height is 68".

Counterweights are required in a single side run configuration as shown.

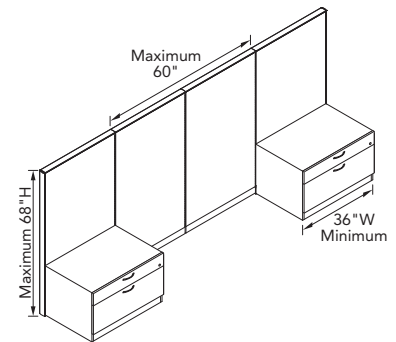

Side-mounted Credenzas — with Return Panel

Use 1 storage-to-panel bracket on Credenza LH or RH of set.

The minimum credenza size is 22"H x 36"W x 18"D.

The minimum size for panel return is 35"H x 36"W.

With a mid-run panel attached floor support, the maximum panel run is 144".

Without a mid-run floor support, the maximum panel run is 96".

Overheads and shelves cannot be used with 22"H side mounted credenzas.

Worksurfaces (if specified) must be mounted on the same side of the parent run as the credenzas.

Panel frame maximum height is 68".

Counterweight is required, if using unit with drawers.

Mid-run floor support options include:

Back-to-Back Credenzas

Panel Attached O-legs

Panel Attached Support Legs

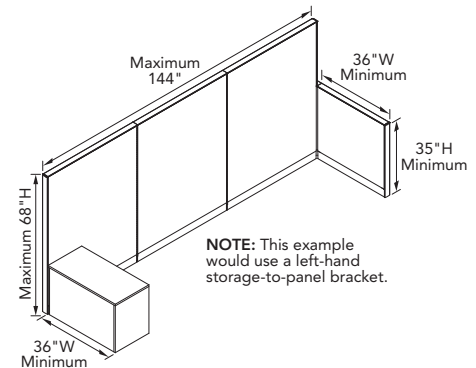

COUNTERWEIGHT REQUIREMENTS FOR CONTAIN[®] CRENZAS

Series	24"W Box/File Unit	30"W Box/File Unit	36"W Box/File Unit	42"W Combo Unit	48"W Combo Unit	60"W Combo Unit	72"W Combo Unit
18"D	HSCACW35 35 lbs. (two 12½ lb. and two 5 lb. counterweights)	HSCACW50 50 lbs. (four 12½ lb. counterweights)	HSCACW50 50 lbs. (four 12½ lb. counterweights)	HSCACW25 25 lbs. (two 12½ lb. counterweights)	HSCACW25 25 lbs. (two 12½ lb. counterweights)	HSCACW35 35 lbs. (two 12½ lb. and two 5 lb. counterweights)	HSCACW35 35 lbs. (two 12½ lb. and two 5 lb. counterweights)

Counterweight is not required if credenzas are used within a standard Systems set up and attached with the Credenza Storage-to-Panel Brackets.



Icon Legend on page 19

CONTAIN[®] Metal Credenzas

	DESCRIPTION	MODEL	SHIP WEIGHT	CUBE	LIST PRICE BY PAINT GRADE		
					P1	P2	P3
	Low Credenza, Box/Lateral Left, Open Shelf Right						
	72"W x 18"D x 22"H	HSCBX227218RBFOM(?) ⓧ	150	20.7	\$1921	\$1988	\$2056
	60"W x 18"D x 22"H	HSCBX226018RBFOM(?) ⓧ	130	17.3	\$1733	\$1800	\$1868
	48"W x 18"D x 22"H	HSCBX224818RBFOM(?) ⓧ	111	14.0	\$1598	\$1665	\$1733
	Low Credenza, Box/Lateral Right, Open Shelf Left						
	72"W x 18"D x 22"H	HSCBX227218LBFOM(?) ⓧ	150	20.7	\$1921	\$1988	\$2056
	60"W x 18"D x 22"H	HSCBX226018LBFOM(?) ⓧ	130	17.3	\$1733	\$1800	\$1868
	48"W x 18"D x 22"H	HSCBX224818LBFOM(?) ⓧ	111	14.0	\$1598	\$1665	\$1733
	Low Credenza, Box/Lateral						
	36"W x 18"D x 22"H	HSCBX223618BFM(?) ⓧ	87	10.6	\$1175	\$1208	\$1243
	30"W x 18"D x 22"H	HSCBX223018BFM(?) ⓧ	76	9.0	\$1125	\$1158	\$1193
	Open Shelf						
	36"W x 18"D x 22"H	HSCBX2236180 ⓧ	66	10.6	\$836	\$869	\$904
	30"W x 18"D x 22"H	HSCBX2230180 ⓧ	60	9.0	\$771	\$804	\$839

STORAGE

NOTES:

- Metal chassis and drawer fronts.
 - Lateral and wide box drawers operate on ball-bearing suspension with full extension.
 - Steel ball-bearing drawer suspensions.
 - Ships complete with standard kickplate.
 - Field installable counterweight sold separately.
 - File drawers accept hanging folders in letter or legal size.
 - Steel frame provides durability.
 - Use with laminate tops and credenza seat cushions. Order separately — see pages 634-635.
- ⓘ Locking units equipped with HON "One Key" interchangeable core removable locks. Keyed alike core model HF23S, in Satin, must be ordered separately. See page 634.
- ⓧ Discontinued 4/6/20.

HOW TO SPECIFY



<p>Select Model Number</p> <p>Replace (?) with handle choice</p> <p>A Satin Chrome Arch N Full Face Integral R Full Radius Pull</p> <p>Pull not specified for Open Shelf models</p>	<p>Select Paint Color</p> <p>See page 625</p>	<p>Select Lock Option</p> <p>L Standard Lock X Omit Lock (deduct \$20)</p> <p>Not specified for models HSCBX2236180 and HSCBX2230180</p>
<p>H S C B X 2 2 7 2 1 8 R B F O M A .</p>	<p>P .</p>	<p>L</p>

CONTAIN[®] Footed Metal Credenzas

GSA SIN 33721

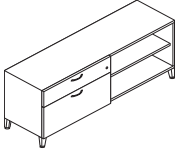
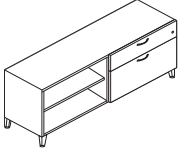

Icon Legend on page 19

	DESCRIPTION	MODEL	SHIP WEIGHT	CUBE	LIST PRICE BY PAINT GRADE		
					P1	P2	P3
	Footed Low Credenza, Box/Lateral Left, Open Shelf Right						
	72"W x 18"D x 22"H	HSCSF227218RBFOM(?) ⓧ	150	17.7	\$2076	\$2143	\$2211
	60"W x 18"D x 22"H	HSCSF226018RBFOM(?) ⓧ	130	14.9	\$1889	\$1956	\$2024
	48"W x 18"D x 22"H	HSCSF224818RBFOM(?) ⓧ	111	12.0	\$1723	\$1790	\$1858
	Footed Low Credenza, Box/Lateral Right, Open Shelf Left						
	72"W x 18"D x 22"H	HSCSF227218LBFOM(?) ⓧ	150	17.7	\$2076	\$2143	\$2211
	60"W x 18"D x 22"H	HSCSF226018LBFOM(?) ⓧ	130	14.9	\$1889	\$1956	\$2024
	48"W x 18"D x 22"H	HSCSF224818LBFOM(?) ⓧ	111	12.0	\$1723	\$1790	\$1858
	Footed Low Credenza, Box/Lateral						
	36"W x 18"D x 22"H	HSCSF223618BFM(?) ⓧ	87	9.1	\$1299	\$1332	\$1367
	30"W x 18"D x 22"H	HSCSF223018BFM(?) ⓧ	76	7.7	\$1249	\$1282	\$1317
	Footed Open Shelf						
	36"W x 18"D x 22"H	HSCSF223618O ⓧ	66	9.1	\$961	\$994	\$1029
	30"W x 18"D x 22"H	HSCSF223018O ⓧ	60	7.7	\$895	\$928	\$963

NOTES:

- Lateral and wide box drawers operate on ball-bearing suspension with full extension.
- Steel ball-bearing drawer suspensions.
- Ships complete with standard footed base.
- Field installable counterweight sold separately.
- File drawers accept hanging folders in letter or legal size.
- Steel frame provides durability.
- Feet are shipped with the credenza unit and are easily assembled.
- Use with laminate tops and credenza seat cushions. Order separately — see pages 634-635.

⚠ Locking units equipped with HON "One Key" interchangeable core removable locks. Keyed alike core model HF23S, in Satin, must be ordered separately. See page 634.

ⓧ Discontinued 4/6/20.

HOW TO SPECIFY

Select Model Number Replace (?) with handle choice A Satin Chrome Arch N Full Face Integral R Full Radius Pull Pull not specified for Open Shelf models	Select Paint Color See page 625	Select Lock Option L Standard Lock X Omit Lock (deduct \$20) Not specified for models HSCSF223618O and HSCSF223018O	Select Foot Color T1 Platinum Metallic PR6 Silver
H S C S F 2 2 7 2 1 8 R B F O M A .	P .	L .	T 1



Icon Legend on page 19

Metal Credenzas with Laminate Fronts

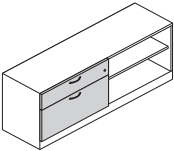
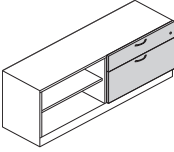
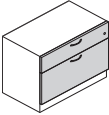
	DESCRIPTION	MODEL	SHIP WEIGHT	CUBE	LIST PRICE BY PAINT GRADE		
					P1	P2	P3
	Metal Low Credenza, Laminated Front, Box/Lateral Left, Open Shelf Right						
	72"W x 18"D x 22"H	HSCBX227218RBFOL(?) ⓧ	152	20.7	\$2131	\$2198	\$2266
	60"W x 18"D x 22"H	HSCBX226018RBFOL(?) ⓧ	132	17.3	\$1943	\$2010	\$2078
	48"W x 18"D x 22"H	HSCBX224818RBFOL(?) ⓧ	113	14.0	\$1808	\$1875	\$1943
	! Replace (?) with handle choice. Available in Satin Chrome Arch only.						
	Metal Low Credenza, Laminated Front, Box/Lateral Right, Open Shelf Left						
	72"W x 18"D x 22"H	HSCBX227218LBFOL(?) ⓧ	152	20.7	\$2131	\$2198	\$2266
	60"W x 18"D x 22"H	HSCBX226018LBFOL(?) ⓧ	132	17.3	\$1943	\$2010	\$2078
	48"W x 18"D x 22"H	HSCBX224818LBFOL(?) ⓧ	113	14.0	\$1808	\$1875	\$1943
	! Replace (?) with handle choice. Available in Satin Chrome Arch only.						
	Metal Low Credenza, Laminated Front Box/Lateral						
	36"W x 18"D x 22"H	HSCBX223618BFL(?) ⓧ	89	10.6	\$1385	\$1418	\$1453
	30"W x 18"D x 22"H	HSCBX223018BFL(?) ⓧ	76	9.0	\$1335	\$1368	\$1403
	! Replace (?) with handle choice. Available in Satin Chrome Arch only.						

STORAGE

NOTES:

- Lateral and wide box drawers operate on ball-bearing suspension with full extension.
- Steel ball-bearing drawer suspensions.
- Ships complete with standard kickplate.
- Field installable counterweight sold separately.
- File drawers accept hanging folders in letter or legal size.
- Steel frame provides durability.
- Use with laminate tops and credenza seat cushions. Order separately — see pages 634-635.

! Available in Satin Chrome Arch only.

! Locking units equipped with HON "One Key" interchangeable core removable locks. Keyed alike core model HF23S, in Satin, must be ordered separately. See page 634.

ⓧ Discontinued 4/6/20.

HOW TO SPECIFY

<p>Select Model Number</p> <p>Replace (?) with handle choice</p> <p>A Satin Chrome Arch</p>	<p>Select Paint Color</p> <p>See page 625</p>	<p>Select Lock Option</p> <p>L Standard Lock X Omit Lock (deduct \$20)</p>	<p>Select Laminate Option</p> <p>See page 625</p>
H S C B X 2 2 7 2 1 8 R B F O L A .	P .	L .	C



Icon Legend on page 19

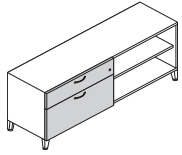

DESCRIPTION

MODEL

SHIP WEIGHT

CUBE

LIST PRICE BY PAINT GRADE

P1

P2

P3

Footed Low Credenza, Laminate Front, Box/Lateral Left, Open Shelf Right

72"W x 18"D x 22"H

HSCSF227218RBFOL(?) ⓧ

152

17.7

\$2287

\$2354

\$2422

60"W x 18"D x 22"H

HSCSF226018RBFOL(?) ⓧ

132

14.9

\$2097

\$2164

\$2232

48"W x 18"D x 22"H

HSCSF224818RBFOL(?) ⓧ

113

12.0

\$1932

\$1999

\$2067

! Replace (?) with handle choice. Available in Satin Chrome Arch only.

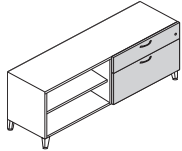

Footed Low Credenza, Laminate Front, Box/Lateral Right, Open Shelf Left

72"W x 18"D x 22"H

HSCSF227218LBFOL(?) ⓧ

152

17.7

\$2287

\$2354

\$2422

60"W x 18"D x 22"H

HSCSF226018LBFOL(?) ⓧ

132

14.9

\$2097

\$2164

\$2232

48"W x 18"D x 22"H

HSCSF224818LBFOL(?) ⓧ

113

12.0

\$1932

\$1999

\$2067

! Replace (?) with handle choice. Available in Satin Chrome Arch only.

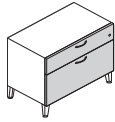

Footed Low Credenza, Laminate Front Box/Lateral

36"W x 18"D x 22"H

HSCSF223618BFL(?) ⓧ

89

9.1

\$1509

\$1542

\$1577

30"W x 18"D x 22"H

HSCSF223018BFL(?) ⓧ

78

7.7

\$1460

\$1493

\$1528

! Replace (?) with handle choice. Available in Satin Chrome Arch only.

NOTES:

- Lateral and wide box drawers operate on ball-bearing suspension with full extension.
- Steel ball-bearing drawer suspensions.
- Ships complete with standard footed base.
- Field installable counterweight sold separately.
- File drawers accept hanging folders in letter or legal size.
- Steel frame provides durability.
- Feet are shipped with the credenza unit and are easily assembled.
- Use with laminate tops and credenza seat cushions. Order separately — see pages 634-635.

! Available in Satin Chrome Arch only.

! Locking units equipped with HON "One Key" interchangeable core removable locks. Keyed alike core model HF23S, in Satin, must be ordered separately. See page 634.



ⓧ Discontinued 4/6/20.

HOW TO SPECIFY

<p>Select Model Number</p> <p>Replace (?) with handle choice</p> <p>A Satin Chrome Arch</p>	<p>Select Paint Color</p> <p>See page 625</p>	<p>Select Lock Option</p> <p>L Standard Lock X Omit Lock (deduct \$20)</p>	<p>Select Laminate Option</p> <p>See page 625</p>	<p>Select Foot Color</p> <p>T1 Platinum Metallic PR6 Silver</p>
H S C S F 2 2 7 2 1 8 R B F O L A .	P .	L .	C .	T 1

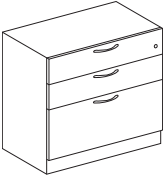

Icon Legend on page 19

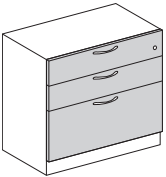
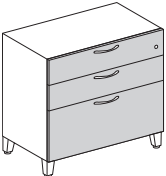
	DESCRIPTION	MODEL	SHIP WEIGHT	CUBE	LIST PRICE BY PAINT GRADE		
					P1	P2	P3
	Box/Box/File 30"W x 18"D x 28"H	HSFCBX283018BBFM(?) Ⓢ	90	11.3	\$1301	\$1334	\$1369
	Footed, Box/Box/File 30"W x 18"D x 28"H	HSFCSF283018BBFM(?) Ⓢ	90	11.3	\$1430	\$1463	\$1498
	Box/Box/File, Laminate Front Base 30"W x 18"D x 28"H ⓘ Available in Satin Chrome Arch only.	HSFCBX283018BBFLA Ⓢ	90	11.3	\$1496	\$1529	\$1564
	Footed, Box/Box/File, Laminate Front 30"W x 18"D x 28"H ⓘ Available in Satin Chrome Arch only.	HSFCSF283018BBFLA Ⓢ	90	11.3	\$1626	\$1659	\$1694

STORAGE

NOTES:

- Lateral and wide box drawers operate on ball-bearing suspension with full extension.
- Steel ball-bearing drawer suspensions.
- Field installable counterweight sold separately.
- File drawers accept hanging folders in letter or legal size.
- Steel frame provides durability.

ⓘ Locking units equipped with HON "One Key" interchangeable core removable locks.

Ⓢ Discontinued 4/6/20.

HOW TO SPECIFY

<p>Select Model Number</p> <p>Replace (?) with handle choice</p> <p>A Satin Chrome Arch N Full Face Integral R Full Radius Pull</p>	<p>Select Paint Color</p> <p>See page 625</p>	<p>Select Lock Option</p> <p>L Standard Lock X Omit Lock (deduct \$20)</p>	<p>Select Laminate Option</p> <p>See page 625</p>
<p>H S F C B X 2 8 3 0 1 8 B B F M A .</p>	<p>P .</p>	<p>L .</p>	<p>C</p>



CONTAIN[®] Lateral Files

OPEN MARKET

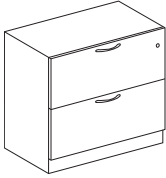

Icon Legend on page 19

STORAGE

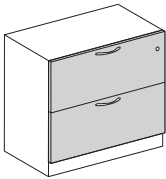
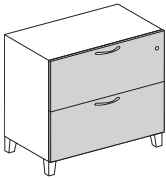
	DESCRIPTION	MODEL	SHIP WEIGHT	CUBE	LIST PRICE BY PAINT GRADE		
					P1	P2	P3
	2 Drawer Lateral 30"W x 18"D x 28"H 36"W x 18"D x 28"H	HSLBX283018FFM(?) ⓧ HSLBX283618FFM(?) ⓧ	90 101	11.3 13.4	\$1012 \$1190	\$1045 \$1223	\$1080 \$1258
	! Replace (?) with handle choice.						
	Footed 2 Drawer Lateral 30"W x 18"D x 28"H 36"W x 18"D x 28"H	HLSLF283018FFM(?) ⓧ HLSLF283618FFM(?) ⓧ	90 101	11.3 13.4	\$1185 \$1309	\$1218 \$1342	\$1253 \$1377
	2 Drawer Lateral, Laminate Front 30"W x 18"D x 28"H 36"W x 18"D x 28"H	HSLBX283018FFLA ⓧ HSLBX283618FFLA ⓧ	98 109	11.3 13.4	\$1254 \$1367	\$1287 \$1400	\$1322 \$1435
	! Available in Satin Chrome Arch only.						
	Footed 2 Drawer Lateral, Laminate Front 30"W x 18"D x 28"H 36"W x 18"D x 28"H	HLSLF283018FFLA ⓧ HLSLF283618FFLA ⓧ	98 109	11.3 13.4	\$1367 \$1504	\$1400 \$1537	\$1435 \$1572
	! Available in Satin Chrome Arch only.						

NOTES:

- Lateral and wide box drawers operate on ball-bearing suspension with full extension.
- Steel ball-bearing drawer suspensions.
- Field installable counterweight sold separately.
- File drawers accept hanging folders in letter or legal size.
- Steel frame provides durability.

! Locking units equipped with HON "One Key" interchangeable core removable locks.

ⓧ Discontinued 4/6/20.

HOW TO SPECIFY

<p>Select Model Number</p> <p>Replace (?) with handle choice</p> <p>A Satin Chrome Arch N Full Face Integral R Full Radius Pull</p>	<p>Select Paint Color</p> <p>See page 625</p>	<p>Select Lock Option</p> <p>L Standard Lock X Omit Lock (deduct \$20)</p>	<p>Select Laminate Option</p> <p>See page 625</p>
<p>H S L B X 2 8 3 0 1 8 F F M A .</p>	<p>P .</p>	<p>L .</p>	<p>C</p>



Icon Legend on page 19

CONTAIN® Lateral File Accessories

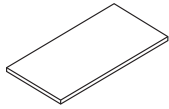

SIN 33721

DESCRIPTION

Credenza Laminate Top — Square Edge

- 72"W x 18"D x 1½" Thick
- 60"W x 18"D x 1½" Thick
- 48"W x 18"D x 1½" Thick
- 36"W x 18"D x 1½" Thick
- 30"W x 18"D x 1½" Thick

MODEL	SHIP WEIGHT	CUBE	LIST PRICE BY LAMINATE GRADE	
			L1	L2
H919472	48	3.5	\$802	\$817
H919460	32	3.0	\$683	\$698
H919448	31	2.6	\$599	\$609
H919436	25 Ⓞ	1.8	\$495	\$505
H919430	20 Ⓞ	1.6	\$395	\$405

NOTES: Square-edge laminate tops provide a finished look to credenzas.

ⓘ Specify laminate only.

SPECIFYING EXAMPLE: H919448.C



OPEN MARKET

DESCRIPTION

Front to Back Hangrail Kits

15"D for 24"D Credenza or 18"D Lateral

ⓘ No specification needed.

MODEL	SHIP WEIGHT	CUBE	LIST PRICE
HSCAHR15	0.1	0.2	\$21

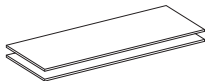

OPEN MARKET

Counterweight for Contain 28"H Laterals

- 50 lbs for 30" Lateral
- 57½ lbs for 36" Lateral

HSLACW50	2.0	55.0	\$203
HSLACW57	2.0	63.0	\$213

STORAGE

HOW TO SPECIFY

<p>Select Model Number</p> <p>H 9 1 9 4 7 2 .</p>	<p>Select Laminate Color</p> <p>See page 625</p> <p>C</p>
<p>Select Model Number</p> <p>H S L A C W 5 0 .</p>	<p>Select Paint Color</p> <p>See page 625</p> <p>S</p>

CONTAIN® Metal Credenzas Accessories

GSA SIN 33721



Icon Legend on page 19

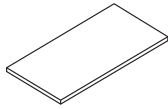

DESCRIPTION	MODEL	SHIP WEIGHT	CUBE	LIST PRICE BY LAMINATE GRADE	
				L1	L2
Credenza Laminate Top — Square Edge					
72"W x 18"D x 1/8" Thick	H919472	48.0	3.5	\$802	\$817
60"W x 18"D x 1/8" Thick	H919460	32.0	3.0	\$683	\$698
48"W x 18"D x 1/8" Thick	H919448	31.0	2.6	\$599	\$609
36"W x 18"D x 1/8" Thick	H919436	25.0 Ⓢ	1.8	\$495	\$505
30"W x 18"D x 1/8" Thick	H919430	20.0 Ⓢ	1.6	\$395	\$405

NOTES: Square-edge laminate tops provide a finished look to credenzas.

! Specify laminate only.

SPECIFYING EXAMPLE: H919448.C

STORAGE

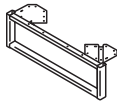

DESCRIPTION	MODEL	SHIP WEIGHT	CUBE	LIST PRICE BY PAINT GRADE		
				P1	P2	P3
Worksurface O-Leg						
30"W x 6 1/2"H	HSCAWS6530	7.0	1.0	\$225	\$235	\$240
24"W x 6 1/2"H	HSCAWS6524	6.0	1.0	\$188	\$198	\$203
20"W x 6 1/2"H	HSCAWS6520	5.0	1.0	\$162	\$172	\$177

NOTES: Worksurfaces with O-Legs may be placed upon Low Credenzas to create layering.

! Specify paint only.

SPECIFYING EXAMPLE: HSCAWS6530.S



Credenza Kickplates						
For 36" Box/File Model	HSCK36BF	3.0	0.5	\$129	\$139	\$154
For 30" Box/File Model	HSCK30BF	2.0	0.4	\$119	\$129	\$144
For 24" Box/File Model	HSCK24BF	2.0	0.4	\$106	\$116	\$131
For 36" Open File Model	HSCK36O	3.0	0.5	\$129	\$139	\$154
For 30" Open File Model	HSCK30O	2.0	0.4	\$119	\$129	\$144

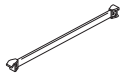

Credenza Hangrail Kits						
12" for front-to-back filing	HSCAHR12	1.0 Ⓢ	0.4	\$18	N/A	N/A

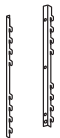

Credenza Storage-to-Panel Bracket	HSCAPB	0.2 Ⓢ	0.4	\$195	\$207	\$215
--	---------------	--------------	-----	--------------	--------------	--------------

Credenza Counterweight Kit

HSCACW50	55.0 Ⓢ	2.0	\$217	N/A	N/A
HSCACW35	40.0 Ⓢ	2.0	\$196	N/A	N/A
HSCACW25	30.0 Ⓢ	2.0	\$174	N/A	N/A

NOTES: Field installable counterweight sold separately.

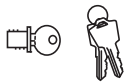

Removable Lock Core Kit—Satin	HF23S	0.2 Ⓢ	0.1	\$40	N/A	N/A
--------------------------------------	--------------	--------------	-----	-------------	------------	------------

• Use when specifying omit lock application.

• Specify quantity of each key number from 101E-225E.

• Includes: 1-core, 2-keys, 1-core removal tool and instructions.

• Removable lock core kits with specific key number must be ordered to facilitate keying alike in the field.

• For specific models, look for the Omit Lock Core icon throughout this publication.

NOTES: If key number isn't specified, number will be at random. Core matches manufactured lock on Contain® product but can be used with Contain® metal casegoods and laminate product.

HOW TO SPECIFY

Select Model Number

H 9 1 9 4 4 8 .

Select Laminate Color

See page 625

C

Select Model Number

H S C A W S 6 5 3 0 .

Select Paint Color

See page 625

S



CONTAIN[®] Metal Credenzas Accessories

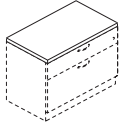

DESCRIPTION	MODEL	SHIP													
		WEIGHT	CUBE	1	2	3	4	5	6	7	8	9	10	11	12
Credenza Cushion 36"W x 18"D for 36", 60", and 72" Credenzas	HSCAUC1836	16.3	1.6	\$278	\$316	\$354	\$393	\$442	\$492	\$542	\$591	\$641	\$690	\$740	\$790
30"W x 18"D for 30", 48", and 60" Credenzas	HSCAUC1830	16.3	1.6	\$259	\$297	\$335	\$374	\$423	\$473	\$523	\$572	\$622	\$671	\$721	\$771
24"W x 18"D for 48" Credenzas	HSCAUC1824	16.3	1.9	\$242	\$280	\$318	\$357	\$406	\$456	\$506	\$555	\$605	\$654	\$704	\$754

NOTES: See pages 22-24 for available fabrics.
SPECIFYING EXAMPLE: HSCAUC1836.APN23

NOTES:

- For matching Pedestal Seats, see page 646.
- Credenza Cushions are available in 24", 30" and 36" size options.
- Choose from multiple upholstery options, see pages 22-24.

HOW TO SPECIFY

Select Model Number	Select Fabric
	See pages 22-24
H S C A U C 1 8 3 6 .	A B 1 0

	DESCRIPTION	MODEL	SHIP WEIGHT	CUBE	LIST PRICE
					P1
	Metal Box Divider				
	10 pack	HSCABD10	7	0.7	\$167
	2 pack	HSCABD02	2	0.7	\$42
! Metal dividers available in Black only. No need to specify.					
	Metal File Divider				
	10 pack	HSCAFD10	12	0.7	\$199
	2 pack	HSCAFD02	3	0.7	\$52
! Metal dividers available in Black only. No need to specify.					

CONTAIN[®] Metal Personal Towers

GSA SIN 33721



Icon Legend on page 19

STORAGE

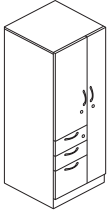

DESCRIPTION	MODEL	SHIP WEIGHT	CUBE	LIST PRICE BY PAINT GRADE		
				P1	P2	P3
Personal Tower with Metal Fronts, Door/Box/Box/File						
65"H x 24"W x 24"D, Wardrobe Left	HSTBX652424LBBFM(?) ⓧ	255	25.6	\$2617	\$2694	\$2762
65"H x 24"W x 24"D, Wardrobe Right	HSTBX652424RBBFM(?) ⓧ	255	25.6	\$2617	\$2694	\$2762
50"H x 24"W x 24"D, Wardrobe Left	HSTBX502424LBBFM(?) ⓧ	215	19.8	\$2146	\$2223	\$2281
50"H x 24"W x 24"D, Wardrobe Right	HSTBX502424RBBFM(?) ⓧ	215	19.8	\$2146	\$2223	\$2281

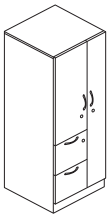

DESCRIPTION	MODEL	SHIP WEIGHT	CUBE	LIST PRICE BY PAINT GRADE		
				P1	P2	P3
Personal Tower with Metal Fronts, Door/File/File						
65"H x 24"W x 24"D, Wardrobe Left	HSTBX652424LFFM(?) ⓧ	255	25.6	\$2617	\$2694	\$2762
65"H x 24"W x 24"D, Wardrobe Right	HSTBX652424RFFM(?) ⓧ	255	25.6	\$2617	\$2694	\$2762
50"H x 24"W x 24"D, Wardrobe Left	HSTBX502424LFFM(?) ⓧ	215	19.8	\$2146	\$2223	\$2281
50"H x 24"W x 24"D, Wardrobe Right	HSTBX502424RFFM(?) ⓧ	215	19.8	\$2146	\$2223	\$2281

NOTES:

- Metal chassis and drawer fronts.
- Steel frame provides durability.
- Leveling glides can be adjusted from outside or inside the case.
- Heavy-duty, telescoping ball-bearing slides.
- Durable baked enamel finish is applied over rust-inhibiting phosphate pre-treatment.
- Three locks secure doors and drawers.
- Pencil tray standard in top box drawer.
- One box divider standard in each box drawer.
- One crossrail standard in each file drawer.

⚠ Locking units equipped with HON "One Key" interchangeable core removable locks. Keyed alike core model HF23S, in Satin, must be ordered separately. See page 634.

ⓧ Discontinued 4/6/20.

HOW TO SPECIFY

Select Model Number

Replace (?) with handle choice

- A** Satin Chrome Arch
- N** Full Face Integral
- R** Full Radius

Select Paint Color

See page 625

Select Lock Option

- L** Standard Lock
- X** Omit Lock (deduct \$60)

H S T B X 6 5 2 4 2 4 L B B F M A . P . L



Icon Legend on page 19

CONTAIN[®] Metal Side Access Towers

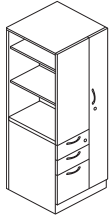

DESCRIPTION	MODEL	SHIP WEIGHT	CUBE	LIST PRICE BY PAINT GRADE		
				P1	P2	P3
Side Access Tower with Metal Fronts, Shelves/Box/Box/File						
65"H x 24"W x 24"D, Wardrobe Left	HSTSBX652424LBBFM(?) Ⓢ	255	25.6	\$2454	\$2531	\$2599
65"H x 24"W x 24"D, Wardrobe Right	HSTSBX652424RBBFM(?) Ⓢ	255	25.6	\$2454	\$2531	\$2599
50"H x 24"W x 24"D, Wardrobe Left	HSTSBX502424LBBFM(?) Ⓢ	215	19.8	\$2082	\$2159	\$2217
50"H x 24"W x 24"D, Wardrobe Right	HSTSBX502424RBBFM(?) Ⓢ	215	19.8	\$2082	\$2159	\$2217

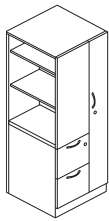

DESCRIPTION	MODEL	SHIP WEIGHT	CUBE	LIST PRICE BY PAINT GRADE		
				P1	P2	P3
Side Access Tower with Metal Fronts, Shelves/File/File						
65"H x 24"W x 24"D, Wardrobe Left	HSTSBX652424LFFM(?) Ⓢ	255	25.6	\$2454	\$2531	\$2599
65"H x 24"W x 24"D, Wardrobe Right	HSTSBX652424RFFM(?) Ⓢ	255	25.6	\$2454	\$2531	\$2599
50"H x 24"W x 24"D, Wardrobe Left	HSTSBX502424LFFM(?) Ⓢ	215	19.8	\$2082	\$2159	\$2217
50"H x 24"W x 24"D, Wardrobe Right	HSTSBX502424RFFM(?) Ⓢ	215	19.8	\$2082	\$2159	\$2217

STORAGE

NOTES:

- A Worksurface to Tower Bracket Kit ships standard with each model.
- Metal chassis and drawer fronts.
- Steel frame provides durability.
- Leveling glides can be adjusted from outside or inside the case.
- Heavy-duty, telescoping ball-bearing slides.
- Durable baked enamel finish is applied over rust-inhibiting phosphate pre-treatment.
- Two locks secure doors and drawers.
- Pencil tray standard in top box drawer.
- One box divider standard in each box drawer.
- One crossrail standard in each file drawer.

ⓘ Locking units equipped with HON "One Key" interchangeable core removable locks. Keyed alike core model HF23S, in Satin, must be ordered separately. See page 634.

Ⓢ Discontinued 4/6/20.

HOW TO SPECIFY

<p>Select Model Number</p> <p>Replace (?) with handle choice</p> <p>A Satin Chrome Arch N Full Face Integral R Full Radius</p>	<p>Select Paint Color</p> <p>See page 625</p>	<p>Select Lock Option</p> <p>L Standard Lock X Omit Lock (deduct \$60)</p>
<p>H S T S B X 6 5 2 4 2 4 L B B F M A .</p>	<p>P .</p>	<p>L</p>



Icon Legend on page 19

STORAGE

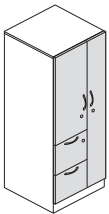
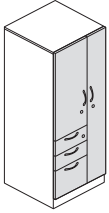

DESCRIPTION	MODEL	SHIP WEIGHT	CUBE	LIST PRICE BY PAINT GRADE		
				P1	P2	P3
Personal Tower with Laminate Fronts, Door/Box/Box/File						
65"H x 24"W x 24"D, Wardrobe Left	HSTBX652424LBBFL(?)	255	25.6	\$2987	\$3064	\$3132
65"H x 24"W x 24"D, Wardrobe Right	HSTBX652424RBBFL(?)	255	25.6	\$2987	\$3064	\$3132
Personal Tower with Laminate Fronts, Door/File/File						
65"H x 24"W x 24"D, Wardrobe Left	HSTBX652424LFFL(?)	255	25.6	\$2987	\$3064	\$3132
65"H x 24"W x 24"D, Wardrobe Right	HSTBX652424RFFL(?)	255	25.6	\$2987	\$3064	\$3132
50"H x 24"W x 24"D, Wardrobe Left	HSTBX502424LBBFL(?)	215	19.8	\$2468	\$2545	\$2603
50"H x 24"W x 24"D, Wardrobe Right	HSTBX502424RBBFL(?)	215	19.8	\$2468	\$2545	\$2603
50"H x 24"W x 24"D, Wardrobe Left	HSTBX502424LFFL(?)	215	19.8	\$2468	\$2545	\$2603
50"H x 24"W x 24"D, Wardrobe Right	HSTBX502424RFFL(?)	215	19.8	\$2468	\$2545	\$2603

NOTES:

- Metal chassis with laminate drawer/door fronts.
- Steel frame provides durability.
- Leveling glides can be adjusted from outside or inside the case.
- Heavy-duty, telescoping ball-bearing slides.
- Durable baked enamel finish is applied over rust-inhibiting phosphate pre-treatment.
- Three locks secure doors and drawers.
- Pencil tray standard in top box drawer.
- One box divider standard in each box drawer.
- One crossrail standard in each file drawer.

ⓘ Available in Satin Chrome Arch only.

ⓘ Locking units equipped with HON "One Key" interchangeable core removable locks. Keyed alike core model HF23S, in Satin, must be ordered separately. See page 634.

ⓧ Discontinued 4/6/20.

HOW TO SPECIFY

<p>Select Model Number</p> <p>Replace (?) with handle choice</p> <p>A Satin Chrome Arch</p>	<p>Select Paint Color</p> <p>See page 625</p>	<p>Select Lock Option</p> <p>L Standard Lock X Omit Lock (deduct \$60)</p>	<p>Select Laminate Option</p> <p>See page 625</p>
H S T B X 6 5 2 4 2 4 L B B F L A .	P .	L .	C



Icon Legend on page 19

Metal Side Access Towers with Laminate Fronts

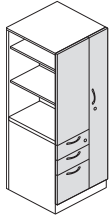

DESCRIPTION	MODEL	SHIP WEIGHT	CUBE	LIST PRICE BY PAINT GRADE		
				P1	P2	P3
Side Access Tower with Laminate Fronts, Shelves/Box/Box/File						
65"H x 24"W x 24"D, Wardrobe Left	HSTSBX652424LBBFL(?) Ⓢ	255	25.6	\$2824	\$2901	\$2969
65"H x 24"W x 24"D, Wardrobe Right	HSTSBX652424RBBFL(?) Ⓢ	255	25.6	\$2824	\$2901	\$2969
50"H x 24"W x 24"D, Wardrobe Left	HSTSBX502424LBBFL(?) Ⓢ	215	19.8	\$2404	\$2481	\$2539
50"H x 24"W x 24"D, Wardrobe Right	HSTSBX502424RBBFL(?) Ⓢ	215	19.8	\$2404	\$2481	\$2539

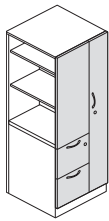

DESCRIPTION	MODEL	SHIP WEIGHT	CUBE	LIST PRICE BY PAINT GRADE		
				P1	P2	P3
Side Access Tower with Laminate Fronts, Shelves/File/File						
65"H x 24"W x 24"D, Wardrobe Left	HSTSBX652424LFFL(?) Ⓢ	255	25.6	\$2824	\$2901	\$2969
65"H x 24"W x 24"D, Wardrobe Right	HSTSBX652424RFFL(?) Ⓢ	255	25.6	\$2824	\$2901	\$2969
50"H x 24"W x 24"D, Wardrobe Left	HSTSBX502424LFFL(?) Ⓢ	215	19.8	\$2404	\$2481	\$2539
50"H x 24"W x 24"D, Wardrobe Right	HSTSBX502424RFFL(?) Ⓢ	215	19.8	\$2404	\$2481	\$2539

STORAGE

NOTES:

- A Worksurface to Tower Bracket Kit ships standard with each model.
- Metal chassis with laminate drawer/door fronts.
- Steel frame provides durability.
- Leveling glides can be adjusted from outside or inside the case.
- Heavy-duty, telescoping ball-bearing slides.
- Durable baked enamel finish is applied over rust-inhibiting phosphate pre-treatment.
- Two locks secure doors and drawers.
- Pencil tray standard in top box drawer.
- One box divider standard in each box drawer.
- One crossrail standard in each file drawer.

ⓘ Available in Satin Chrome Arch only.

ⓘ Locking units equipped with HON "One Key" interchangeable core removable locks. Keyed alike core model HF23S, in Satin, must be ordered separately. See page 634.

Ⓢ Discontinued 4/6/20.

HOW TO SPECIFY

<p>Select Model Number</p> <p>Replace (?) with handle choice</p> <p>A Satin Chrome Arch</p>	<p>Select Paint Color</p> <p>See page 625</p>	<p>Select Lock Option</p> <p>L Standard Lock X Omit Lock (deduct \$60)</p>	<p>Select Laminate Option</p> <p>See page 625</p>
HSTSBX652424LBBFLA	P	L	C

CONTAIN[®] Footed Metal Personal Towers

GSA SIN 33721



Icon Legend on page 19

STORAGE

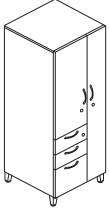

DESCRIPTION	MODEL	SHIP WEIGHT	CUBE	LIST PRICE BY PAINT GRADE		
				P1	P2	P3
Footed Personal Tower with Metal Fronts, Door/Box/Box/File						
65"H x 24"W x 24"D, Wardrobe Left	HSTSF652424LBBFM(?) ⓧ	255	24.3	\$2736	\$2813	\$2881
65"H x 24"W x 24"D, Wardrobe Right	HSTSF652424RBBFM(?) ⓧ	255	24.3	\$2736	\$2813	\$2881
50"H x 24"W x 24"D, Wardrobe Left	HSTSF502424LBBFM(?) ⓧ	215	18.6	\$2267	\$2344	\$2402
50"H x 24"W x 24"D, Wardrobe Right	HSTSF502424RBBFM(?) ⓧ	215	18.6	\$2267	\$2344	\$2402

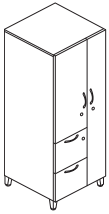

Footed Personal Tower with Metal Fronts, Door/File/File						
65"H x 24"W x 24"D, Wardrobe Left	HSTSF652424LFFM(?) ⓧ	255	24.3	\$2736	\$2813	\$2881
65"H x 24"W x 24"D, Wardrobe Right	HSTSF652424RFFM(?) ⓧ	255	24.3	\$2736	\$2813	\$2881
50"H x 24"W x 24"D, Wardrobe Left	HSTSF502424LFFM(?) ⓧ	215	18.6	\$2267	\$2344	\$2402
50"H x 24"W x 24"D, Wardrobe Right	HSTSF502424RFFM(?) ⓧ	215	18.6	\$2267	\$2344	\$2402

NOTES:

- Metal chassis and drawer fronts.
- Steel frame provides durability.
- Leveling glides can be adjusted from outside or inside the case.
- Heavy-duty, telescoping ball-bearing slides.
- Durable baked enamel finish is applied over rust-inhibiting phosphate pre-treatment.
- Three locks secure doors and drawers.
- Pencil tray standard in top box drawer.
- One box divider standard in each box drawer.
- One crossrail standard in each file drawer.

⚠ Locking units equipped with HON "One Key" interchangeable core removable locks. Keyed alike core model HF23S, in Satin, must be ordered separately. See page 634.

ⓧ Discontinued 4/6/20.

HOW TO SPECIFY

Select Model Number

Replace (?) with handle choice

- A** Satin Chrome Arch
- N** Full Face Integral
- R** Full Radius

H S T S F 6 5 2 4 2 4 L B B F M A .

Select Paint Color

See page 625

P .

Select Lock Option

- L** Standard Lock
- X** Omit Lock (deduct \$60)

L .

Select Foot Color

- T1** Platinum Metallic
- PR6** Silver

T 1



Icon Legend on page 19

Footed Metal Side Access Towers

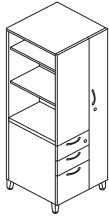

DESCRIPTION	MODEL	SHIP WEIGHT	CUBE	LIST PRICE BY PAINT GRADE		
				P1	P2	P3
Footed Side Access Tower with Metal Fronts, Shelves/Box/Box/File						
65”H x 24”W x 24”D, Wardrobe Left	HSTSSF652424LBBFM(?) Ⓢ	255	24.3	\$2573	\$2650	\$2718
65”H x 24”W x 24”D, Wardrobe Right	HSTSSF652424RBBFM(?) Ⓢ	255	24.3	\$2573	\$2650	\$2718
50”H x 24”W x 24”D, Wardrobe Left	HSTSSF502424LBBFM(?) Ⓢ	215	18.6	\$2202	\$2279	\$2337
50”H x 24”W x 24”D, Wardrobe Right	HSTSSF502424RBBFM(?) Ⓢ	215	18.6	\$2202	\$2279	\$2337

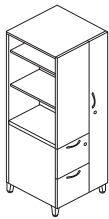

Footed Side Access Tower with Metal Fronts, Shelves/File/File						
65”H x 24”W x 24”D, Wardrobe Left	HSTSSF652424LFFM(?) Ⓢ	255	24.3	\$2573	\$2650	\$2718
65”H x 24”W x 24”D, Wardrobe Right	HSTSSF652424RFFM(?) Ⓢ	255	24.3	\$2573	\$2650	\$2718
50”H x 24”W x 24”D, Wardrobe Left	HSTSSF502424LFFM(?) Ⓢ	215	18.6	\$2202	\$2279	\$2337
50”H x 24”W x 24”D, Wardrobe Right	HSTSSF502424RFFM(?) Ⓢ	215	18.6	\$2202	\$2279	\$2337

STORAGE

NOTES:

- A Worksurface to Tower Bracket Kit ships standard with each model.
- Metal chassis and drawer fronts.
- Steel frame provides durability.
- Leveling glides can be adjusted from outside or inside the case.
- Heavy-duty, telescoping ball-bearing slides.
- Durable baked enamel finish is applied over rust-inhibiting phosphate pre-treatment.
- Two locks secure doors and drawers.
- Pencil tray standard in top box drawer.
- One box divider standard in each box drawer.
- One crossrail standard in each file drawer.

ⓘ Locking units equipped with HON “One Key” interchangeable core removable locks. Keyed alike core model HF23S, in Satin, must be ordered separately. See page 634.

Ⓢ Discontinued 4/6/20.

HOW TO SPECIFY

<p>Select Model Number</p> <p>Replace (?) with handle choice</p> <p>A Satin Chrome Arch N Full Face Integral R Full Radius</p>	<p>Select Paint Color</p> <p>See page 625</p>	<p>Select Lock Option</p> <p>L Standard Lock X Omit Lock (deduct \$60)</p>	<p>Select Foot Color</p> <p>T1 Platinum Metallic PR6 Silver</p>
<p>H S T S S F 6 5 2 4 2 4 L B B F M A .</p>	<p>P .</p>	<p>L .</p>	<p>T 1</p>



Icon Legend on page 19

STORAGE

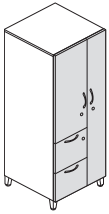
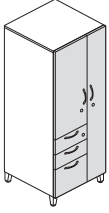

DESCRIPTION	MODEL	SHIP WEIGHT	CUBE	LIST PRICE BY PAINT GRADE		
				P1	P2	P3
Footed Personal Tower with Laminate Fronts, Door/Box/Box/File						
65"H x 24"W x 24"D, Wardrobe Left	HSTSF652424LBBFL(?) Ⓢ	255	24.3	\$3107	\$3184	\$3252
65"H x 24"W x 24"D, Wardrobe Right	HSTSF652424RBBFL(?) Ⓢ	255	24.3	\$3107	\$3184	\$3252
50"H x 24"W x 24"D, Wardrobe Left	HSTSF502424LBBFL(?) Ⓢ	215	18.6	\$2589	\$2666	\$2724
50"H x 24"W x 24"D, Wardrobe Right	HSTSF502424RBBFL(?) Ⓢ	215	18.6	\$2589	\$2666	\$2724
Footed Personal Tower with Laminate Fronts, Door/File/File						
65"H x 24"W x 24"D, Wardrobe Left	HSTSF652424LFFL(?) Ⓢ	255	24.3	\$3107	\$3184	\$3252
65"H x 24"W x 24"D, Wardrobe Right	HSTSF652424RFFL(?) Ⓢ	255	24.3	\$3107	\$3184	\$3252
50"H x 24"W x 24"D, Wardrobe Left	HSTSF502424LFFL(?) Ⓢ	215	18.6	\$2589	\$2666	\$2724
50"H x 24"W x 24"D, Wardrobe Right	HSTSF502424RFFL(?) Ⓢ	215	18.6	\$2589	\$2666	\$2724

NOTES:

- Metal chassis with laminate drawer/door fronts.
 - Steel frame provides durability.
 - Leveling glides can be adjusted from outside or inside the case.
 - Heavy-duty, telescoping ball-bearing slides.
 - Durable baked enamel finish is applied over rust-inhibiting phosphate pre-treatment.
 - Three locks secure doors and drawers.
 - Pencil tray standard in top box drawer.
 - One box divider standard in each box drawer.
 - One crossrail standard in each file drawer.
- ⓘ Available in Satin Chrome Arch only.
- ⓘ Locking units equipped with HON "One Key" interchangeable core removable locks. Keyed alike core model HF23S, in Satin, must be ordered separately. See page 634.
- Ⓢ Discontinued 4/6/20.

HOW TO SPECIFY

<p>Select Model Number</p> <p>Replace (?) with handle choice</p> <p>A Satin Chrome Arch</p>	<p>Select Paint Color</p> <p>See page 625</p>	<p>Select Lock Option</p> <p>L Standard Lock X Omit Lock (deduct \$60)</p>	<p>Select Laminate Option</p> <p>See page 625</p>	<p>Select Foot Color</p> <p>T1 Platinum Metallic PR6 Silver</p>
H S T S F 6 5 2 4 2 4 L B B F L A .	P .	L .	C .	T 1



Icon Legend on page 19

Footed Metal Side Access Towers with Laminate Fronts

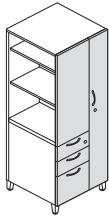

DESCRIPTION	MODEL	SHIP WEIGHT	CUBE	LIST PRICE BY PAINT GRADE		
				P1	P2	P3
Footed Side Access Tower with Laminate Fronts, Shelves/Box/Box/File						
65"H x 24"W x 24"D, Wardrobe Left	HSTSSF652424LBBFL(?) Ⓢ	255	24.3	\$2944	\$3021	\$3089
65"H x 24"W x 24"D, Wardrobe Right	HSTSSF652424RBBFL(?) Ⓢ	255	24.3	\$2944	\$3021	\$3089
50"H x 24"W x 24"D, Wardrobe Left	HSTSSF502424LBBFL(?) Ⓢ	215	18.6	\$2524	\$2601	\$2659
50"H x 24"W x 24"D, Wardrobe Right	HSTSSF502424RBBFL(?) Ⓢ	215	18.6	\$2524	\$2601	\$2659

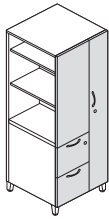

Footed Side Access Tower with Laminate Fronts, Shelves/File/File						
65"H x 24"W x 24"D, Wardrobe Left	HSTSSF652424LFFL(?) Ⓢ	255	24.3	\$2944	\$3021	\$3089
65"H x 24"W x 24"D, Wardrobe Right	HSTSSF652424RFFL(?) Ⓢ	255	24.3	\$2944	\$3021	\$3089
50"H x 24"W x 24"D, Wardrobe Left	HSTSSF502424LFFL(?) Ⓢ	215	18.6	\$2524	\$2601	\$2659
50"H x 24"W x 24"D, Wardrobe Right	HSTSSF502424RFFL(?) Ⓢ	215	18.6	\$2524	\$2601	\$2659



Tower Kickplates (Field Installable)						
For 24" Tower, Left	HSTAKL Ⓢ	2	0.3	\$158	\$166	\$171
For 24" Tower, Right	HSTAKR Ⓢ	2	0.3	\$158	\$166	\$171
Specify: Model.Paint						
SPECIFYING EXAMPLE: HSATKL.P						

NOTES:

- A Worksurface to Tower Bracket Kit ships standard with each model.
- Metal chassis with laminate drawer/door fronts.
- Steel frame provides durability.
- Leveling glides can be adjusted from outside or inside the case.
- Heavy-duty, telescoping ball-bearing slides.
- Durable baked enamel finish is applied over rust-inhibiting phosphate pre-treatment.
- Two locks secure doors and drawers.
- Pencil tray standard in top box drawer.
- One box divider standard in each box drawer.
- One crossrail standard in each file drawer.

ⓘ Available in Satin Chrome Arch only.

ⓘ Locking units equipped with HON "One Key" interchangeable core removable locks. Keyed alike core model HF23S, in Satin, must be ordered separately. See page 634.

Ⓢ Discontinued 4/6/20.

STORAGE

HOW TO SPECIFY

<p>Select Model Number</p> <p>Replace (?) with handle choice</p> <p>A Satin Chrome Arch</p>	<p>Select Paint Color</p> <p>See page 625</p>	<p>Select Lock Option</p> <p>L Standard Lock X Omit Lock (deduct \$60)</p>	<p>Select Laminate Option</p> <p>See page 625</p>	<p>Select Foot Color</p> <p>T1 Platinum Metallic PR6 Silver</p>
H S T S S F 6 5 2 4 2 4 L B B F L A .	P .	L .	C .	T 1

CONTAIN[®] Metal Pedestals

GSA SIN 33721



Icon Legend on page 19

STORAGE

	DESCRIPTION	MODEL	SHIP WEIGHT	CUBE	LIST PRICE BY PAINT GRADE		
					P1	P2	P3
	Hanging Pedestal with Metal Fronts, Box/File						
	18"H x 15"W x 18"D	HSPH181518BFM(?) ⓧ	35.8	4.4	\$559	\$587	\$615
	18"H x 15"W x 24"D	HSPH181524BFM(?) ⓧ	39.3	5.7	\$595	\$623	\$651
	18"H x 15"W x 30"D	HSPH181530BFM(?) ⓧ	45.6	6.4	\$629	\$657	\$685
	Mobile Pedestal with Metal Fronts, Box/File						
	21"H x 15"W x 18"D	HSPM211518BFM(?) ⓧ	63.5	4.4	\$559	\$587	\$615
	21"H x 15"W x 24"D	HSPM211524BFM(?) ⓧ	61.9	5.7	\$599	\$627	\$655
	Mobile Pedestal with Metal Fronts, Box/Box/File						
	27"H x 15"W x 18"D	HSPM271518BBFM(?) ⓧ	63.4	5.3	\$723	\$751	\$779
	27"H x 15"W x 24"D	HSPM271524BBFM(?) ⓧ	71.9	6.6	\$763	\$791	\$819
	27"H x 15"W x 30"D	HSPM271530BBFM(?) ⓧ	83.6	8.2	\$803	\$831	\$859
	Mobile Pedestal with Metal Fronts, File/File						
	27"H x 15"W x 18"D	HSPM271518FFM(?) ⓧ	60.9	5.3	\$723	\$751	\$779
	27"H x 15"W x 24"D	HSPM271524FFM(?) ⓧ	65.7	6.6	\$763	\$791	\$819
	27"H x 15"W x 30"D	HSPM271530FFM(?) ⓧ	75.2	8.2	\$803	\$831	\$859
	Plinth Support Pedestal with Metal Fronts, Box/Box/File						
	28"H x 15"W x 18"D	HSPSBX281518BBFM(?) ⓧ	50.4	5.9	\$699	\$727	\$755
	28"H x 15"W x 24"D	HSPSBX281524BBFM(?) ⓧ	58.6	7.5	\$738	\$766	\$794
	28"H x 15"W x 30"D	HSPSBX281530BBFM(?) ⓧ	69.8	9.3	\$778	\$806	\$834
	Plinth Support Pedestal with Metal Fronts, File/File						
	28"H x 15"W x 18"D	HSPSBX281518FFM(?) ⓧ	45.1	5.9	\$699	\$727	\$755
	28"H x 15"W x 24"D	HSPSBX281524FFM(?) ⓧ	52.1	7.5	\$738	\$766	\$794
	28"H x 15"W x 30"D	HSPSBX281530FFM(?) ⓧ	61.1	9.3	\$778	\$806	\$834

NOTES:

- Ball-bearing suspension on box and file drawer. (100%)
- Drawers color to be interior gray steel.
- See page 646 for Pedestal Seat.
- File drawer has high sides and back for filing front to back and side to side.
- Counterweight standard on all mobile peds.
- Pencil tray standard in top box drawer.
- One box divider standard in each box drawer.
- One crossrail standard in each file drawer.
- 24"D and 30"D pedestals accommodate legal files side to side.
- ⓘ A-Pull available in Satin Chrome only.
- ⓘ Locking units equipped with HON "One Key" interchangeable core removable locks. Keyed alike core model HF23S, in Satin, must be ordered separately. See page 634.
- ⓧ Discontinued 4/6/20.

HOW TO SPECIFY

<p>Select Model Number</p> <p>Replace (?) with handle choice</p> <p>A Satin Chrome Arch N Full Face Integral R Full Radius</p> <p>H S P H 1 8 1 5 1 8 B F M A .</p>	<p>Select Paint Color</p> <p>See page 625</p> <p>P .</p>	<p>Select Lock Option</p> <p>L Standard Lock X Omit Lock (deduct \$20)</p> <p>L</p>
---	---	--



Icon Legend on page 19

CONTAIN[®] Footed Metal Pedestals

	DESCRIPTION	MODEL	SHIP WEIGHT	CUBE	LIST PRICE BY PAINT GRADE		
					P1	P2	P3
	Footed Freestanding Pedestal with Metal Fronts, Box/File						
	22"H x 15"W x 18"D 22"H x 15"W x 24"D	HSPFSF221518BFM(?) HSPFSF221524BFM(?)	66.8 73.1	4.4 5.7	\$656 \$694	\$684 \$722	\$712 \$750
	Footed Support Pedestal with Metal Fronts, Box/Box/File						
	28"H x 15"W x 18"D 28"H x 15"W x 24"D 28"H x 15"W x 30"D	HSPSSF281518BBFM(?) HSPSSF281524BBFM(?) HSPSSF281530BBFM(?)	49.8 57.4 68.3	5.3 6.6 8.2	\$821 \$858 \$899	\$849 \$886 \$927	\$877 \$914 \$955
	Footed Support Pedestal with Metal Fronts, File/File						
	28"H x 15"W x 18"D 28"H x 15"W x 24"D 28"H x 15"W x 30"D	HSPSSF281518FFM(?) HSPSSF281524FFM(?) HSPSSF281530FFM(?)	47.3 54.3 60.0	5.3 6.6 8.2	\$821 \$858 \$899	\$849 \$886 \$927	\$877 \$914 \$955
	Flush Pedestal Kickplates (Field Installable)	HSPAK15	2.0	0.2	\$108	\$116	\$121
	Specify: Model.Paint SPECIFYING EXAMPLE: HSPAK.P						

STORAGE

NOTES:

- Ball-bearing suspension on box and file drawer. (100%)
- Drawers color to be interior gray steel.
- File drawer has high sides and back for filing front to back and side to side.
- Counterweight standard on all mobile peds.
- See page 646 for Pedestal Seat.
- Pencil tray standard in top box drawer.
- One box divider standard in each box drawer.
- One crossrail standard in each file drawer.
- 24"D and 30"D pedestals accommodate legal files side to side.
- ! A-Pull available in Satin Chrome only.
- ! Locking units equipped with HON "One Key" interchangeable core removable locks. Keyed alike core model HF23S, in Satin, must be ordered separately. See page 634.

HOW TO SPECIFY

<p>Select Model Number</p> <p>Replace (?) with handle choice</p> <p>A Satin Chrome Arch N Full Face Integral R Full Radius</p> <p>H S P F S F 2 2 1 5 1 8 B F M A .</p>	<p>Select Paint Color</p> <p>See page 625</p> <p>P .</p>	<p>Select Lock Option</p> <p>L Standard Lock X Omit Lock (deduct \$20)</p> <p>L .</p>	<p>Select Foot Color</p> <p>T1 Platinum Metallic PR6 Silver</p> <p>T 1</p>
---	---	--	---

CONTAIN[®] Footed Metal Pedestals

GSA SIN AS NOTED



Icon Legend on page 19

	DESCRIPTION	MODEL	SHIP WEIGHT	CUBE	LIST PRICE
SIN 33721	Counterweight — Freestanding Support Pedestals or Systems Support and Mobile Pedestals	HPCW1	18	0.1	\$195

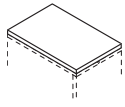

OPEN MARKET

DESCRIPTION	MODEL	SHIP WEIGHT	CUBE	FABRIC PRICE CODES			
Pedestal Seat 15"W x 22 ⁷ / ₈ "D x 2"H NOTES: For seating fabrics, see pages 22-24. SPECIFYING EXAMPLE: HPSEAT24ND.APN23	HPSEAT24ND	10	1.2	1	\$194	8	\$390
				2	\$218	9	\$421
				3	\$242	10	\$452
				4	\$266	11	\$483
				5	\$297	12	\$514
				6	\$328	L	—
				7	\$359		

STORAGE

HOW TO SPECIFY

Select Model Number	Select Fabric See pages 22-24 for seating fabric options
H P S E A T 2 4 .	A P N 2 3



Icon Legend on page 19

Metal Pedestals with Laminate Fronts

	DESCRIPTION	MODEL	SHIP WEIGHT	CUBE	LIST PRICE BY PAINT GRADE		
					P1	P2	P3
	Hanging Pedestal with Laminate Fronts, Box/File						
	18"H x 15"W x 18"D, Arch Pull	HSPH181518BFL(?)	37.6	4.4	\$715	\$743	\$771
	18"H x 15"W x 24"D, Arch Pull	HSPH181524BFL(?)	43.9	5.7	\$750	\$778	\$806
	18"H x 15"W x 30"D, Arch Pull	HSPH181530BFL(?)	53.0	6.4	\$785	\$813	\$841
	Mobile Pedestal with Laminate Fronts, Box/File						
	21"H x 15"W x 18"D, Arch Pull	HSPM211518BFL(?)	65.3	4.4	\$715	\$743	\$771
	21"H x 15"W x 24"D, Arch Pull	HSPM211524BFL(?)	63.7	5.7	\$755	\$783	\$811
	Mobile Pedestal with Laminate Fronts, Box/Box/File						
	27"H x 15"W x 18"D, Arch Pull	HSPM271518BBFL(?)	65.0	5.3	\$928	\$956	\$984
	27"H x 15"W x 24"D, Arch Pull	HSPM271524BBFL(?)	73.5	6.6	\$966	\$994	\$1022
	27"H x 15"W x 30"D, Arch Pull	HSPM271530BBFL(?)	85.2	8.2	\$1008	\$1036	\$1064
	Mobile Pedestal with Laminate Fronts, File/File						
	27"H x 15"W x 18"D, Arch Pull	HSPM271518FFL(?)	63.4	5.3	\$928	\$956	\$984
	27"H x 15"W x 24"D, Arch Pull	HSPM271524FFL(?)	68.1	6.6	\$966	\$994	\$1022
	27"H x 15"W x 30"D, Arch Pull	HSPM271530FFL(?)	77.6	8.2	\$1008	\$1036	\$1064
	Plinth Support Pedestal with Laminate Fronts, Box/Box/File						
	28"H x 15"W x 18"D, Arch Pull	HSPSBX281518BBFL(?)	51.7	5.9	\$904	\$932	\$960
	28"H x 15"W x 24"D, Arch Pull	HSPSBX281524BBFL(?)	59.9	7.5	\$942	\$970	\$998
	28"H x 15"W x 30"D, Arch Pull	HSPSBX281530BBFL(?)	71.1	9.3	\$983	\$1011	\$1039
	Plinth Support Pedestal with Laminate Fronts, File/File						
	28"H x 15"W x 18"D, Arch Pull	HSPSBX281518FFL(?)	47.6	5.9	\$904	\$932	\$960
	28"H x 15"W x 24"D, Arch Pull	HSPSBX281524FFL(?)	54.6	7.5	\$942	\$970	\$998
	28"H x 15"W x 30"D, Arch Pull	HSPSBX281530FFL(?)	63.6	9.3	\$983	\$1011	\$1039

STORAGE

NOTES:

- Ball-bearing suspension on box and file drawer. (100%)
- Drawers color to be interior gray steel.
- File drawer has high sides and back for filing front to back and side to side.
- Counterweight standard on all mobile peds.
- See page 646 for Pedestal Seat.
- Pencil tray standard in top box drawer.
- One box divider standard in each box drawer.
- One crossrail standard in each file drawer.
- 24"D and 30"D pedestals accommodate legal files side to side.

! Drawer Fronts available with Satin Chrome Arch only.

! Locking units equipped with HON "One Key" interchangeable core removable locks. Keyed alike core model HF23S, in Satin, must be ordered separately. See page 634.

HOW TO SPECIFY

<p>Select Model Number</p> <p>Replace (?) with handle choice</p> <p>A Satin Chrome Arch</p> <p>H S P H 1 8 1 5 1 8 B F L A .</p>	<p>Select Paint Color</p> <p>See page 625</p> <p>P .</p>	<p>Select Lock Option</p> <p>L Standard Lock X Omit Lock (deduct \$20)</p> <p>L .</p>	<p>Select Laminate Option</p> <p>See page 625</p> <p>C</p>
--	---	--	---



Icon Legend on page 19

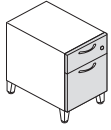

DESCRIPTION

MODEL

SHIP WEIGHT

CUBE

LIST PRICE BY PAINT GRADE

P1

P2

P3

Footed Freestanding Pedestal with Laminate Fronts, Box/File

22"H x 15"W x 18"D, Arch Pull
22"H x 15"W x 24"D, Arch Pull

HSPFSF221518BFL(?)
HSPFSF221524BFL(?)

69.0
75.3

4.4
5.7

\$812
\$850

\$840
\$878

\$868
\$906

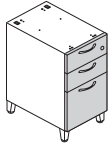

Footed Support Pedestal with Laminate Fronts, Box/Box/File

28"H x 15"W x 18"D, Arch Pull
28"H x 15"W x 24"D, Arch Pull
28"H x 15"W x 30"D, Arch Pull

HSPSSF281518BBFL(?)
HSPSSF281524BBFL(?)
HSPSSF281530BBFL(?)

51.4
59.0
69.9

5.3
6.6
8.2

\$1024
\$1063
\$1102

\$1052
\$1091
\$1130

\$1080
\$1119
\$1158

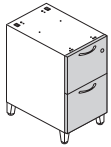

Footed Support Pedestal with Laminate Fronts, File/File

28"H x 15"W x 18"D, Arch Pull
28"H x 15"W x 24"D, Arch Pull
28"H x 15"W x 30"D, Arch Pull

HSPSSF281518FFL(?)
HSPSSF281524FFL(?)
HSPSSF281530FFL(?)

49.7
56.7
62.4

5.3
6.6
8.2

\$1024
\$1063
\$1102

\$1052
\$1091
\$1130

\$1080
\$1119
\$1158

STORAGE

NOTES:

- Ball-bearing suspension on box and file drawer. (100%)
- Drawers color to be interior gray steel.
- File drawer has high sides and back for filing front to back and side to side.
- Counterweight standard on all mobile peds.
- See page 646 for Pedestal Seat.
- Pencil tray standard in top box drawer.
- One box divider standard in each box drawer.
- One crossrail standard in each file drawer.
- 24"D and 30"D pedestals accommodate legal files side to side.

! Drawer Fronts available with Satin Chrome Arch only.

! Locking units equipped with HON "One Key" interchangeable core removable locks. Keyed alike core model HF23S, in Satin, must be ordered separately. See page 634.

HOW TO SPECIFY

<p>Select Model Number</p> <p>Replace (?) with handle choice</p> <p>A Satin Chrome Arch</p>	<p>Select Paint Color</p> <p>See page 625</p>	<p>Select Lock Option</p> <p>L Standard Lock X Omit Lock (deduct \$20)</p>	<p>Select Laminate Option</p> <p>See page 625</p>	<p>Select Foot Color</p> <p>T1 Platinum Metallic PR6 Silver</p>
H S P F S F 2 2 1 5 1 8 B F L A .	P .	L .	C .	T 1



Footed Metal Pedestals with Laminate Fronts

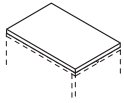

DESCRIPTION

Pedestal Seat
15"W x 22⁷/₈"D x 2"H

NOTES: For seating fabrics, see pages 22-24.
SPECIFYING EXAMPLE: HPSEAT24ND.APN23

MODEL	SHIP WEIGHT	CUBE	FABRIC PRICE CODES			
HPSEAT24ND	10	1.2	1	\$194	8	\$390
			2	\$218	9	\$421
			3	\$242	10	\$452
			4	\$266	11	\$483
			5	\$297	12	\$514
			6	\$328	L	—
			7	\$359		

NOTES:

- See Brigade® pedestals on page 615 for additional pedestal options. See pages 679-680 for Pedestal Accessories.

STORAGE

HOW TO SPECIFY

<p>Select Model Number</p> <p>HPSEAT24.</p>	<p>Select Fabric</p> <p>See pages 22-24 for seating fabric options</p> <p>APN23</p>
--	--

FLAGSHIP®

STORAGE



Flagship® Modular Storage.

FLAGSHIP®

Pedestals in more than 40 styles. Lateral files in 15 sizes. These are just some of the reasons why Flagship is one of HON's top metal storage collections, and why HON is America's filing and storage leader. Today's offices run on information, and Flagship helps them sort, store and share every bit of it — plus all of the personal items and daily supplies employees depend on. It's the best-built storage available from any manufacturer at any price.



FEATURES

- Rugged, high-quality construction makes HON America's leader in filing and storage.
- ColorCorrect® lets you match your Flagship storage to many office furniture manufacturers.
- Add seat cushions to mobile pedestals for short-term, stow-away guest seating.
- Modular Storage with bins for easy access and customization.
- Lateral files with storage cabinets not only corral all your info, they double as collaborative hubs.
- Squeeze more storage capacity into a smaller workstation footprint by using pedestals as worksurface supports.
- Archival filing doesn't have to be stuffy. Outfit any open space with a wall full of storage, available at a moment's notice.

FLAGSHIP® ORDERING INFORMATION

FLAGSHIP® PRODUCTS

PAINTS CODES

P1	
◆ Black	P
◆ Brownstone	P7D
◆ Charcoal	S
◆ Designer White	PJW
◆ Fossil	P28
◆ Greige	T5
◆ Light Gray	Q
◆ Loft	LOFT
◆ Muslin	T3
◆ Putty	L
◆ Shadow *	SHDW
◆ Titanium	P8T
P2	
◆ Champagne Metallic	T4
◆ Platinum Metallic	T1

OPTIONAL LAMINATE TOPS FOR LATERAL FILES

L1 LAMINATES CODES

Woodgrain	
◆ Bourbon Cherry	H
◆ Cognac	COGN
◆ Florence Walnut	LFW1
◆ Harvest	C
◆ Kingswood Walnut	LK11
◆ Mahogany	N
◆ Mocha	MOCH
◆ Natural Maple	D
◆ Pinnacle	PINC
◆ Shaker Cherry	F
Solid	
◆ Charcoal	S
◆ Designer White	LDW1
◆ Loft	LOFT

Patterned	
◆ Sheer Mesh*	A5
◆ Silver Mesh*	B9
◆ Steel Mesh*	A9
◆ Canyon Zephyr	K9
◆ Desert Zephyr	K8
◆ Shadow Zephyr	K1
◆ Gray*	G2
◆ White*	G1

L2 LAMINATES CODES

Woodgrain	
◆ Lowell Ash	LLA1
◆ Natural Recon	LNRI
◆ Phantom Ecru	LPE1
◆ Portico Teak	LPT1
◆ Skyline Walnut	LSW1

PULL OPTIONS FOR CONTAIN® AND FLAGSHIP® STORAGE

Suffix "A"



Satin Chrome
Arch Pull

Suffix "N"



Full Face Integral
Drawer Pull

Suffix "R"



Full Radius
Drawer Pull

NOTES: Arch pulls available in Satin Chrome only.

* Laminate colors will have the following pre-set edgeband colors:

<i>Laminate</i>	<i>Edge</i>
Sheer Mesh	Muslin
Silver Mesh	Loft
Steel Mesh	Charcoal
Gray	Charcoal
White	Charcoal

Edgeband matches top except as noted.

For Champagne Metallic Paint, Muslin is the suggested edgeband color. When Champagne Metallic Paint is selected, pulls are standard in Muslin.

◆◆◆ For lead time information see page 19.

* De-emphasized



STORAGE

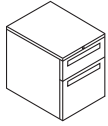

DESCRIPTION

Hanging Pedestals — Box/File

15"W x 16 7/8"D x 19 1/2"H
15"W x 22 7/8"D x 19 1/2"H

MODEL

SHIP WEIGHT

CUBE

LIST PRICE BY PAINT GRADE

P1

P2

P3

H14917(?)	41	4.4	\$530	\$558	\$586
H14923(?)	48	6.0	\$564	\$592	\$620

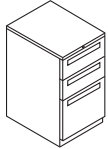

Standard Height Mobile Pedestals — Box/Box/File

15"W x 16 7/8"D x 28"H
15"W x 22 7/8"D x 28"H
15"W x 28 7/8"D x 28"H

H18717(?)	76	5.9	\$679	\$707	\$735
H18723(?)	88	8.0	\$730	\$758	\$786
H18730(?)	102	9.8	\$784	\$812	\$840

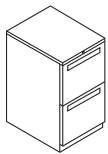

Standard Height Mobile Pedestals — File/File

15"W x 16 7/8"D x 28"H
15"W x 22 7/8"D x 28"H
15"W x 28 7/8"D x 28"H

H18817(?)	72	5.9	\$673	\$701	\$729
H18823(?)	85	8.0	\$723	\$751	\$779
H18830(?)	98	9.8	\$777	\$805	\$833



Standard Height Freestanding Support Pedestals — Box/Box/File

15"W x 16 7/8"D x 28"H
15"W x 22 7/8"D x 28"H
15"W x 28 7/8"D x 28"H

H19717(?)	59	5.9	\$668	\$696	\$724
H19723(?)	73	8.0	\$719	\$747	\$775
H19730(?)	87	9.8	\$773	\$801	\$829

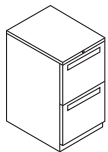

Standard Height Freestanding Support Pedestals — File/File

15"W x 16 7/8"D x 28"H
15"W x 22 7/8"D x 28"H
15"W x 28 7/8"D x 28"H

H19817(?)	55	5.9	\$661	\$689	\$717
H19823(?)	70	8.0	\$712	\$740	\$768
H19830(?)	83	9.8	\$765	\$793	\$821

NOTES:

- 28"H fits under all HON worksurfaces and desk shells.
- 22 7/8"D and 28 7/8"D pedestals accommodate legal files side to side.
- Pencil tray standard in top box drawer.
- One box divider standard in each box drawer.
- One crossrail standard in each file drawer.
- Steel ball-bearing suspension on file and box drawers.
- Full extension on all drawers.
- File drawers have high sides for filing front-to-back.
- See pages 679-680 for accessories and pedestal utilization information.
- Equipped with HON "One Key" interchangeable core removable locks.
- Hanging units are mounted using keyhole slots in top of pedestals; all hardware provided.
- Arch pull available in Satin Chrome only.
- Available in Arch (A), Full Face Integral (N) and Full Radius (R) Drawer Pulls. See page 612 for pull options.
- Choose from any of three pull options with no upcharge.
- Counterweight standard in mobile pedestals.
- Omit lock-option available. See page 853 for ordering instructions.
- See Brigade® pedestals on page 615 for additional pedestal options. See pages 679-680 for Pedestal Accessories.

! Freestanding support pedestals that are not positioned and attached under a worksurface require a counterweight kit found on page 679.

HOW TO SPECIFY

<p>Select Model Number</p> <p>A Satin Chrome Arch N Full Face Integral R Full Radius</p> <p>H 1 4 9 1 7 A</p>	<p>Select Lock Option</p> <p>L Lock (no upcharge) X Omit Lock (deduct \$20)</p> <p>L</p>	<p>Select Paint Color</p> <p>See page 651</p> <p>P</p>
---	--	--



FLAGSHIP® Mobile Pedestals



H15923N

SIN 33721

DESCRIPTION

Mobile Pedestals — Box/File
15"W x 22⁷/₈"D x 22"H

MODEL	SHIP WEIGHT	CUBE	LIST PRICE BY PAINT GRADE		
			P1	P2	P3
H15923(?)	92	6.0	\$569	\$597	\$625

NOTES:

- Pencil tray standard in top box drawer.
- One box divider standard in each box drawer.
- One crossrail standard in each file drawer.
- File drawers have high sides for filing front-to-back.
- Steel ball-bearing suspension on file drawer, and box drawer.
- See pages 679-680 for accessories and pedestal utilization information.
- Arch pull available in Satin Chrome only.
- Choose from any of three pull options with no upcharge.
- Available in Arch (A), Full Face Integral (N) and Full Radius (R) Drawer Pulls. See page 651 for pull options.
- Equipped with HON "One Key" interchangeable core removable locks.
- Counterweight standard.
- Omit lock-option available. See page 853 for ordering instructions.

HOW TO SPECIFY

<p>Select Model Number</p> <p>A Satin Chrome Arch N Full Face Integral R Full Radius</p> <p>H 1 5 9 2 3 A .</p>	<p>Select Lock Option</p> <p>L Lock (no upcharge) X Omit Lock (deduct \$20)</p> <p>X .</p>	<p>Select Paint Color</p> <p>See page 651</p> <p>T 1</p>
--	---	---

DESCRIPTION

Pedestal Seat
15"W x 22⁷/₈"D x 2"H
NOTES: For seating fabrics, see pages 22-24.

MODEL	SHIP WEIGHT	CUBE	FABRIC PRICE CODES			
HPSEAT24ND	10 Ⓢ	1.2	1 \$194	8 \$390	2 \$218	9 \$421
			3 \$242	10 \$452	4 \$266	11 \$483
			5 \$297	12 \$514	6 \$328	L —
			7 \$359			

OPEN MARKET

NOTES:

- See Brigade® pedestals on page 615 for additional pedestal options. See pages 679-680 for Pedestal Accessories.

HOW TO SPECIFY

<p>Select Model Number</p> <p>H P S E A T 2 4 .</p>	<p>Select Fabric</p> <p>See pages 22-24 for seating fabric options</p> <p>A P N 2 3</p>
--	--

STORAGE

FLAGSHIP®

18" Deep Lateral Files with Drawers

GSA SIN 33721



Icon Legend on page 19

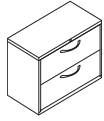

Standard Height

DESCRIPTION

Standard Height Lateral File — 2 Drawer

30"W x 18"D x 28"H
36"W x 18"D x 28"H
42"W x 18"D x 28"H

MODEL

H9170(?)
H9180(?)
H9190(?)

SHIP WEIGHT

138
156
177

CUBE

12.3
14.5
16.8

LIST PRICE BY PAINT GRADE

P1 **P2** **P3**

\$960 **\$993** **\$1027**
\$1062 **\$1095** **\$1129**
\$1228 **\$1261** **\$1295**

Lateral File — 3 Drawer

30"W x 18"D x 39¹/₈"H
36"W x 18"D x 39¹/₈"H
42"W x 18"D x 39¹/₈"H

H9173(?)
H9183(?)
H9193(?)

150
174
197

16.9
20.0
23.2

\$1259 **\$1292** **\$1326**
\$1413 **\$1446** **\$1480**
\$1634 **\$1667** **\$1701**

Lateral File w/o Posting Shelf — 4 Drawer

30"W x 18"D x 52¹/₂"H
36"W x 18"D x 52¹/₂"H
42"W x 18"D x 52¹/₂"H

H9174(?)
H9184(?)
H9194(?)

176
198
213

22.1
26.2
30.3

\$1585 **\$1652** **\$1718**
\$1800 **\$1867** **\$1933**
\$2065 **\$2132** **\$2198**

Lateral File w/o Posting Shelf — 5 Drawer

30"W x 18"D x 64¹/₄"H
36"W x 18"D x 64¹/₄"H
42"W x 18"D x 64¹/₄"H

H9175(?)
H9185(?)
H9195(?)

203
238
264

26.8
31.8
36.8

\$2025 **\$2092** **\$2158**
\$2280 **\$2347** **\$2413**
\$2644 **\$2711** **\$2777**

NOTES: Top drawer is a roll-out shelf.

STORAGE

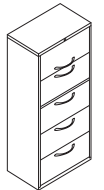
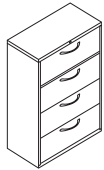
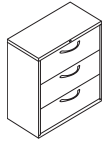

NOTES:

- 28"H lateral fit under standard 38000 Series and worksurfaces.
- Flush top and sides.
- Reinforced case construction.
- Lock mechanism serves both sides of drawer.
- Equipped with HON "One Key" interchangeable core removable locks.
- Counterweight included where applicable to meet ANSI/BIFMA stability requirements.
- Three-part, telescoping, steel ball-bearing suspension.
- Features drawer extension restraint; mechanical interlock inhibits the extension of more than one drawer at a time.
- Optional laminate tops and accessories — see page 676.
- Matching Pedestals — see page 652.
- Omit lock-option available. See page 853 for ordering instructions.
- Arch pull available in Satin Chrome only.
- Choose from any of three pull options with no upcharge.
- Available in Arch (A), Full Face Integral (N) and Full Radius (R) Drawer Pulls. See below and page 651 for pull options.
- See page 676 for Lateral File Accessories.

HOW TO SPECIFY

<p>Select Model Number</p> <p>Select the Pull</p> <p>A Satin Chrome Arch N Full Face Integral R Full Radius</p> <p>H 9 1 7 0 A</p>	<p>Select Lock Option</p> <p>L Lock (no upcharge) X Omit Lock (deduct \$20)</p> <p>L</p>	<p>Select Paint Color</p> <p>See page 651</p> <p>P</p>
--	--	--



Icon Legend on page 19

FLAGSHIP[®] Lateral File with Storage

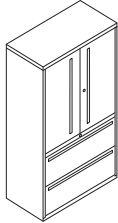

Model H9185LSN shown

DESCRIPTION

Lateral Files with Storage and Hinged Doors
36"W x 18"D x 64¼"H

MODEL	SHIP WEIGHT	CUBE	LIST PRICE BY PAINT GRADE		
			P1	P2	P3
H9185LS(?)	203	31.8	\$2185	\$2252	\$2318

NOTES: Lateral File drawers lock independently from storage case.

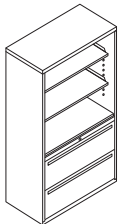

Model H9185LSNN shown

Lateral Files with Open Shelves, No Doors
36"W x 18"D x 64¼"H

H9185LSN(?)	184	31.8	\$1994	\$2061	\$2127
-------------	-----	------	--------	--------	--------

STORAGE

NOTES:

- 64¼"H models complement Flagship lateral file heights.
- Equipped with HON "One Key" interchangeable core removable locks. Locks on storage cabinet doors and lateral file are keyed alike.
- Three-part, telescoping, steel ball-bearing suspension.
- Includes two adjustable shelves, adjustable in 2" increments.
- Lock mechanism serves both sides of drawer.
- Features drawer extension restraint; mechanical interlock inhibits the extension of more than one drawer at a time.
- Wire management grommet in back of unit.
- Omit lock-option available. See page 853 for ordering instructions.
- Flush top and sides.
- Choose from any of three pull options with no upcharge.
- Arch pull available in Satin Chrome only.
- Available in Arch (A), Full Face Integral (N) and Full Radius (R) Drawer Pulls. See page 651 for pull options.

HOW TO SPECIFY

<p>Select Model Number</p> <p>Select the Pull</p> <p>A Satin Chrome Arch N Full Face Integral R Full Radius</p> <p>H 9 1 8 5 L S A .</p>	<p>Select Lock Option</p> <p>L Lock (no upcharge) X Omit Lock (deduct \$40 for models H91756LS and H9185LS) (deduct \$20 for models H9175LSN and H9185LSN)</p> <p>X .</p>	<p>Select Paint Color</p> <p>See page 651</p> <p>P</p>
--	--	---

FLAGSHIP® Modular Storage

GSA SIN 33721



Icon Legend on page 19

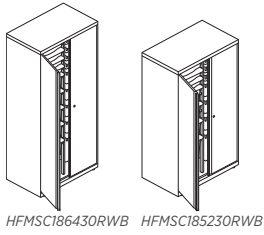

DESCRIPTION

Modular Storage Cabinet

- 18"D x 28"H x 30"W
- 18"D x 39½"H x 30"W
- 18"D x 52½"H x 30"W
- 18"D x 64¼"H x 30"W

MODEL	SHIP WEIGHT	CUBE	LIST PRICE BY PAINT GRADE		
			P1	P2	P3
HFMSC182830RWB	119	12.0	\$1035	\$1068	\$1102
HFMSC183930RWB	138	16.2	\$1254	\$1287	\$1321
HFMSC185230RWB	176	22.4	\$1514	\$1581	\$1647
HFMSC186430RWB	184	28.2	\$1766	\$1833	\$1899

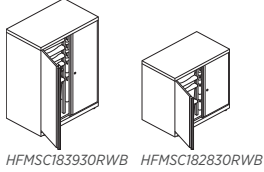

STORAGE

NOTES:

- Shipped fully assembled.
- Pre-configured trays and rails are included, see chart below.
- Additional Tray Kits may be purchased separately.
- Full radius handle on both doors.
- Four adjustable leveling glides standard.
- Reinforced top and base.
- Equipped with HON "One Key" interchangeable core removable locks standard.
- Doors have vertical stiffener standard.
- Positive door stops.
- Meets or exceeds ANSI/BIFMA and ISTA standards.
- Certified SCS Indoor Advantage Gold.

Pre-Configured Cabinets/Tray Kits

64" High Cabinet		52" High Cabinet		39" High Cabinet		28" High Cabinet	
1	2	1	2	1	2	1	2
3	4	3	4	3	4	3	4
5	6	5	6	5	6	5	6
7	8	7	8	7	8	7	8
1	2	1	2	1	2	1	2
3	4	3	4	3	4	3	4
5	6	5	6	5	6	5	6
7	8	7	8	7	8	7	8
1	2	1	2	1	2	1	2
						3	4

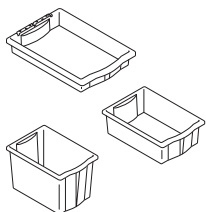

DESCRIPTION

Accessories — Tray Kit

- 3"H, 2 bins and 4 rails
- 6"H, 2 bins and 4 rails
- 12"H, 2 bins and 4 rails

NOTES: Modular Storage Cabinets come with rails and bins. Additional bins and rails may be ordered in sets of 2. Availability and usage are outlined below.

MODEL	SHIP WEIGHT	CUBE	LIST PRICE
HFMBIN3	7 Ⓢ	4.0	\$50
HFMBIN6	10 Ⓢ	4.5	\$62
HFMBIN12	12 Ⓢ	5.0	\$73

NOTES:

- Tray height options include: 3", 6", 12".
- Trays may only be used in 12" width single column/section only.
- All trays are suspended off a pair of storage rails, trays slide easily in and out and are removable.
- Trays and storage rails are field installed and may be easily reconfigured.
- Front and rear handles are integrated for easy handling/transport.
- Translucent material provides visibility to contents.

HOW TO SPECIFY

Select Model Number

H F M S C 1 8 6 4 3 0 R W B .

Select Lock Option

- L Lock (no upcharge)
 - X Omit Lock (deduct \$20)
- See page 853 for omit lock ordering instructions

L .

Select Glide

- G Glide

G .

Select Paint Color

See page 651

L D W 1

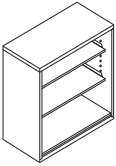
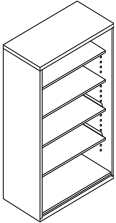

	DESCRIPTION	MODEL	SHIP WEIGHT	CUBE	LIST PRICE BY PAINT GRADE		
					P1	P2	P3
	3 Shelf 36"W x 18"D x 39½"H	HFSC183640W	100	20.0	\$856	\$889	\$923
	5 Shelf 36"W x 18"D x 64¼"H NOTES: 64¼"H models complement Flagship lateral file heights.	HFSC183664W	148	31.8	\$1269	\$1336	\$1402

STORAGE

NOTES:

- Flush top and sides.
- Reinforced case construction.
- Shelves adjust in 2" increments.
- Wire management grommet in back of unit.

HOW TO SPECIFY

<p>Select Model Number</p> <p>H F S C 1 8 3 6 4 0 W .</p>	<p>Select Paint Color</p> <p>See page 651</p> <p>P</p>
--	---

FLAGSHIP® Storage Cabinets

GSA SIN 33721



Icon Legend on page 19

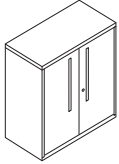

Model HFSC183640N shown

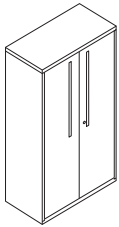

Model HFSC183664N shown

DESCRIPTION	MODEL	SHIP WEIGHT	CUBE	LIST PRICE BY PAINT GRADE		
				P1	P2	P3
Storage Cabinets 36"W x 18"D x 39 7/8"H (with lock) 2 adjustable shelves	HFSC183640(?)	119	20.0	\$1061	\$1128	\$1194
36"W x 18"D x 64 1/4"H (with lock) 4 adjustable shelves NOTES: 64 1/4"H models complement Flagship lateral file heights.	HFSC183664(?)	184	31.8	\$1546	\$1613	\$1679

NOTES:

- Flush top and sides.
- Reinforced case construction.
- Includes adjustable shelves, adjustable in 2" increments.
- Arch pull available in Satin Chrome only.
- Choose from any of three pull options with no upcharge.
- Available in Arch (A), Full Face Integral (N) and Full Radius (R) Drawer Pulls. See below and page 651 for pull options.
- Four adjustable leveling glides are standard.
- Equipped with HON "One Key" interchangeable core removable locks.
- Wire management grommet in back of unit.
- Omit lock-option available. See page 853 for ordering instructions.

HOW TO SPECIFY

<p>Select Model Number</p> <p>Select the Pull</p> <p>A Satin Chrome Arch N Full Face Integral R Full Radius</p> <p>H F S C 1 8 3 6 4 0 A .</p>	<p>Select Lock Option</p> <p>L Lock (no upcharge) X Omit Lock (deduct \$20)</p> <p>L .</p>	<p>Select Paint Color</p> <p>See page 651</p> <p>P</p>
---	--	---

FLAMESAFE™ ORDERING INFORMATION

FLAMESAFE™ PRODUCTS

PAINTS CODES

P1

- ◆ Black P
- ◆ Light Gray Q
- ◆ Putty L

STORAGE

◆◆◆ For lead time information see page 19.

FLAMESAFE™ Fire-Resistant Files

OPEN MARKET



Icon Legend on page 19

STORAGE



DESCRIPTION

Vertical File — 2-Drawer, Letter
17³/₄"W x 25"D x 27³/₄"H

MODEL SHIP WEIGHT CUBE LIST PRICE

H52 320 10.0 \$3508

Vertical File — 2-Drawer, Legal
20³/₄"W x 25"D x 27³/₄"H

H52C 341 13.0 \$3598

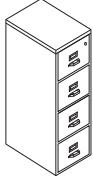

Vertical File — 4-Drawer, Letter
17³/₄"W x 25"D x 52³/₄"H

H54 546 17.0 \$5401

Vertical File — 4-Drawer, Legal
20³/₄"W x 25"D x 52³/₄"H

H54C 596 21.0 \$5514

NOTES:

- Full suspension.
- Non-asbestos.
- Follower block standard (spring-loaded).
- Chrome drawer pulls, thumb latch and label holder.
- Rated: Filing Device Class 350, 1700° for one hour with drop test.
- UL listed.
- High drawer sides.
- Available in Putty, Black and Gray only; see page 659.
- Insulated in drawer face and between drawers.
- **Full Lifetime Warranty.**

! Lock is NOT core removable.

HOW TO SPECIFY

Select Model Number <input type="text" value="H52"/>	Select Lock Option <input type="text" value="P"/>	Select Paint Color See page 659 <input type="text" value="P"/>
--	---	---

DESCRIPTION

Lateral File — 2-Drawer
31¹/₈"W x 22¹/₈"D x 27³/₄"H

MODEL SHIP WEIGHT CUBE LIST PRICE

H32 436 11.0 \$5167



Lateral File — 4-Drawer
31¹/₈"W x 22¹/₈"D x 52³/₄"H

H34 723 26.0 \$7797

NOTES: Lateral Drawer inside dimensions: 25³/₈"W x 15¹/₈"D x 10³/₈"H

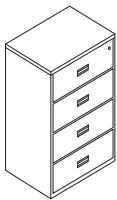

NOTES:

- Telescoping suspension.
- Non-asbestos.
- Available in Putty, Black and Gray only; see page 659.
- Rated: Filing Device Class 350, 1700° for one hour with drop test.
- Insulated in drawer face and between drawers.
- UL listed.
- 4 hangrails per opening, standard.
- Black, plastic recessed drawer pulls.
- **Full Lifetime Warranty.**

! Lock is NOT core removable.

HOW TO SPECIFY

Select Model Number <input type="text" value="H32"/>	Select Lock Option <input type="text" value="P"/>	Select Paint Color P Black Q Light Gray L Putty <input type="text" value="P"/>
--	---	---



Customized Filing Solutions with Fuse™.

FUSE™

Who says storage has to be boring? With a completely modern take on form and function, not to mention an ultra-cool color palette, Fuse storage adds personality to any home office or corporate workspace. With personal storage space for just about everything, Fuse keeps you organized even in small spaces.



FEATURES

- Designed to make the most of the compressed footprint of desking, benching and height-adjustable workstations.
- Extra thick, low profile case provides increased strength and durability while providing a modern 360-degree aesthetic for your storage needs.
- Extended height drawers give you the extra capacity to neatly store what matters most to you.
- Add a pop of color with an optional two-tone design to give new meaning to personal space.
- Alcove for stowing backpack, purse, bag, or other personal items.
- Rear casters swivel and front casters are fixed for easier mobility.
- Casters are designed to clear the top of Coordinate™ feet.
- File drawer has high sides to allow front-to-back filing for 15" wide models.
- Side-to-side filing uses file bars for support for 10" wide models.
- Standard core removable locks make rekeying a breeze.

FUSE™ ORDERING INFORMATION

STORAGE

FUSE™ PRODUCTS

PAINTS CODES

P1

- ◆ Black P
- ◆ Brownstone P7D
- ◆ Designer White PJW
- ◆ Charcoal P02
- ◆ Fossil*** P28
- ◆ Greige T5
- ◆ Loft LOFT
- ◆ Muslin T3
- ◆ Titanium P8T

P2*

- ◆ Champagne Metallic T4
- ◆ Silver PR6
- ◆ Solar Black P8X

P3**

- ◆ Atom P8S
- ◆ Blossom*** P8K
- ◆ Bullseye PJF
- ◆ Cabernet*** P7T
- ◆ Conifer*** P8H
- ◆ Ember P8P
- ◆ Ion P8N
- ◆ Iris P8J
- ◆ Krypton P8F
- ◆ Regatta P8M
- ◆ Succulent*** P8A

PULLS

- ◆ Square Silver SPR6
- ◆ Linear Silver LPR6
- ◆ Linear Black LP

WORKPLACE TOOLS

- ◆ Designer White DW

PULL OPTIONS FOR FUSE™ STORAGE



Square



Linear

*P2 upcharges \$18 for each dot option selected.

**P3 upcharges \$40 for each dot option selected.

***TREND COLORS: These colors are intended to be an inspirational option for the trending market. Product application is limited and color availability is approximately two years to coincide with evolving workplace trends.

- The HON Company has elected to discontinue the HON Choice paint program, as of 12/31/2018, and roll it into our standard specials process.
- A special request will need to be submitted to receive pricing and order information.

◆◆◆ For lead time information see page 19.

Fuse Pedestal Functionality with Workplace Tools

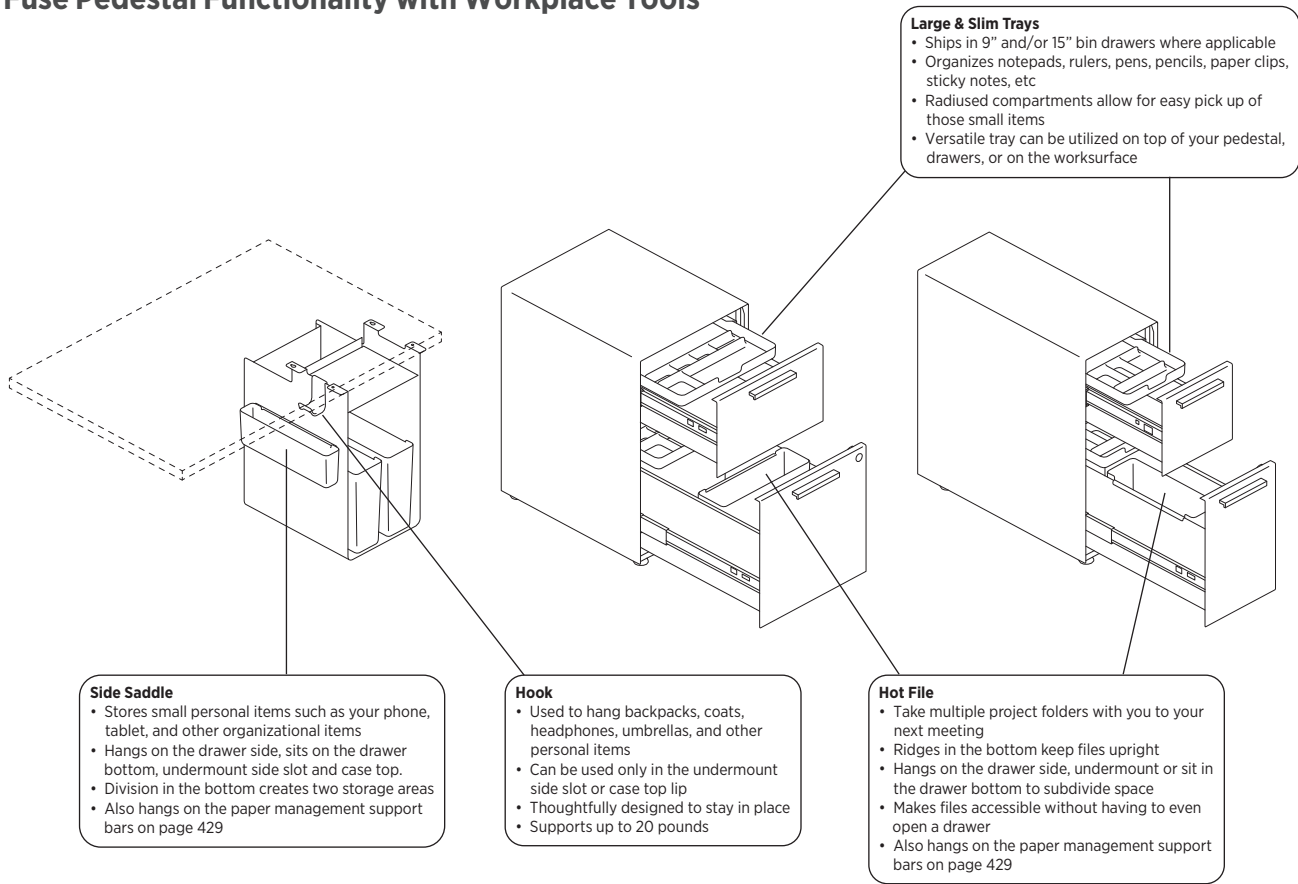

Configuration Options - Fuse

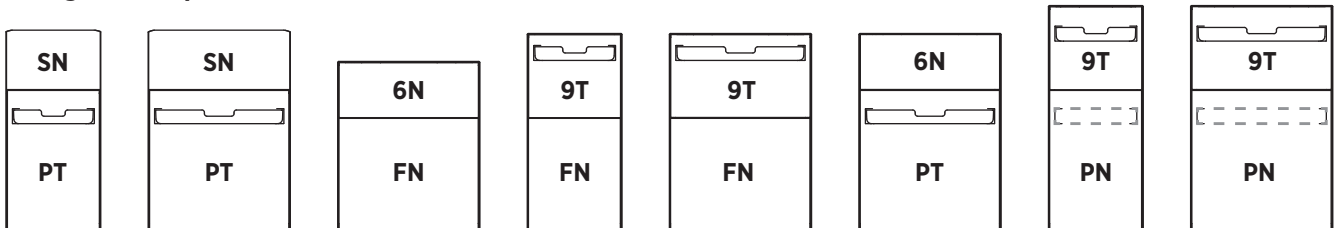

Legend

- 6N = 6" Box No Tray
- 9T = 9" Box Bin with Tray
- SN = Alcove
- FN = 12" File No Tray
- PN = 15" File No Tray
- PT = 15" Bin with Tray

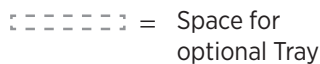
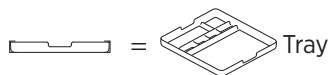

FUSE™ Mobile Pedestals

OPEN MARKET



Icon Legend on page 19

STORAGE

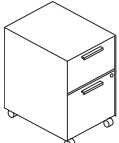
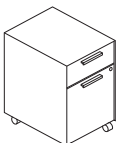
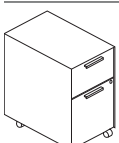
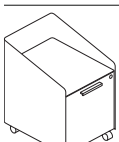
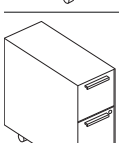
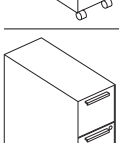
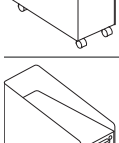
	DESCRIPTION	MODEL	SHIP WEIGHT	CUBE	LIST PRICE
	Mobile Pedestal, 6" Box/12" File 15"W x 19"D x 20 ³ / ₈ "H 15"W x 23"D x 20 ³ / ₈ "H	HAPMAP196NFN	48	5.0	\$599
		HAPMAP236NFN	54	5.9	\$643
	NOTES: No tray, Specification of tray color not required.				
	Mobile Pedestal, 9" Bin with Tray/12" File 15"W x 19"D x 23 ³ / ₈ "H 15"W x 23"D x 23 ³ / ₈ "H	HAPMBP199TFN	53	5.7	\$675
		HAPMBP239TFN	58	6.7	\$722
	Mobile Pedestal, 6" Box/15" Bin with Tray 15"W x 19"D x 23 ³ / ₈ "H 15"W x 23"D x 23 ³ / ₈ "H	HAPMBP196NPT	53	5.7	\$675
		HAPMBP236NPT	58	6.7	\$722
	Mobile Pedestal, 9" Bin with Tray/15" Bin 15"W x 19"D x 26 ³ / ₈ "H 15"W x 23"D x 26 ³ / ₈ "H	HAPMCP199TPN	58	6.4	\$727
		HAPMCP239TPN	62	7.5	\$773
	Mobile Pedestal, Alcove/15" File with Tray 15"W x 19"D x 21 ¹ / ₂ "H	HAPMBP19SNPT	58	5.7	\$628
	NOTES: Top matches drawer color.				
	Slim Mobile Pedestal, 9" Bin with Tray/12" File 10"W x 23"D x 23 ³ / ₈ "H	HAPMBS239TFN	47	4.9	\$687
	Slim Mobile Pedestal, 9" Bin with Tray/15" Bin 10"W x 23"D x 26 ³ / ₈ "H	HAPMCS239TPN	52	5.4	\$739
	Slim Mobile Pedestal, Alcove/15" Bin with Tray 10"W x 23"D x 21 ¹ / ₂ "H	HAPMBS23SNPT	43	4.9	\$640
	NOTES: Top matches drawer color.				

HOW TO SPECIFY

Select Model Number H A P M A P 1 9 6 N F N .	Select Pull Option SPR6 Square Silver LPR6 Linear Silver LP Linear Black	Select Case Color See page 662 P2 upcharge (+ \$18) P3 upcharge (+ \$40)	Select Drawer Color See page 662 P2 upcharge (+ \$18) P3 upcharge (+ \$40)	Select Tray Color DW Designer White	Select Lock Option L Standard Lock X Omit Lock (deduct \$20)
---	--	--	--	---	---



Icon Legend on page 19

Freestanding Pedestals

	DESCRIPTION	MODEL	SHIP WEIGHT	CUBE	LIST PRICE
	Freestanding Pedestal, 9" Bin with Tray/12" File 15"W x 19"D x 21"H 15"W x 23"D x 21"H	HAPGBP199TFN	53	5.7	\$656
		HAPGBP239TFN	58	5.7	\$701
	Freestanding Pedestal, 6" Box/15" Bin with Tray 15"W x 19"D x 21"H 15"W x 23"D x 21"H	HAPGBP196NPT	53	5.7	\$656
		HAPGBP236NPT	58	5.7	\$701
	Freestanding Pedestal, 9" Bin with Tray/15" Bin 15"W x 19"D x 24"H 15"W x 23"D x 24"H	HAPGCP199TPN	58	5.7	\$706
		HAPGCP239TPN	62	5.7	\$751
	Freestanding Pedestal, Alcove/15" Bin with Tray 15"W x 19"D x 21"H NOTES: Top matches drawer color.	HAPGBP19SNPT	45	5.7	\$610
	Slim Freestanding Pedestal, 9" Bin with Tray/12" File 10"W x 23"D x 21"H	HAPGBS239TFN	47	5.7	\$667
	Slim Freestanding Pedestal, 9" Bin with Tray/15" Bin 10"W x 23"D x 24"H	HAPGCS239TPN	52	5.4	\$717
	Slim Freestanding Pedestal, Alcove/15" Bin with Tray 10"W x 23"D x 21"H NOTES: Top matches drawer color.	HAPGBS23SNPT	43	4.9	\$621

STORAGE

HOW TO SPECIFY

Select Model Number H A P G B P 1 9 9 T F N .	Select Pull Option SPR6 Square Silver LPR6 Linear Silver LP Linear Black	Select Case Color See page 662 P2 upcharge (+ \$18) P3 upcharge (+ \$40)	Select Drawer Color See page 662 P2 upcharge (+ \$18) P3 upcharge (+ \$40)	Select Tray Color DW Designer White	Select Lock Option L Standard Lock X Omit Lock (deduct \$20)
---	--	--	--	---	---

FUSE™ Pedestal Cushion

OPEN MARKET



Icon Legend on page 19

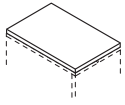

DESCRIPTION

Seat Cushion
For 19"D Pedestal

MODEL

HAESC19

SHIP WEIGHT

6

CUBE

1.0

FABRIC PRICE CODES

1	\$185	8	\$323
2	\$209	9	\$341
3	\$233	10	\$359
4	\$251	11	\$377
5	\$269	12	\$395
6	\$287	L	—
7	\$305		

STORAGE

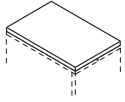

Seat Cushion
For 23"D Pedestal

HPSEAT24ND

10

1.2

1	\$194	8	\$390
2	\$218	9	\$421
3	\$242	10	\$452
4	\$266	11	\$483
5	\$297	12	\$514
6	\$328	L	—
7	\$359		

HOW TO SPECIFY

Select
Model Number

Select
Fabric

See pages 22-24 for seating fabric options

HAESC19

CU10

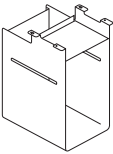
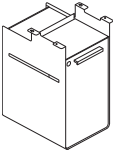

FUSE™ Undermount Storage

	DESCRIPTION	MODEL	SHIP WEIGHT	CUBE	LIST PRICE
	Undermount Storage Cubby NOTES: No need to specify door color or lock option.	HAUFO15N	19	3.3	\$364
	Undermount Storage Cubby with Locking Door Right-Hinged Left-Hinged NOTES: Right-Hinged shown.	HAUFHR15N HAUFHL15N	24 24	3.3 3.3	\$432 \$432

NOTES:

- Compatible with all HON benching, desking, and height adjustable tables, except where required space is unavailable.
 - Ensure weight limit of height adjustable table system is considered before adding undermount storage.
 - Open and hinged door units contain a side slot on each side which can be used to hang Workplace Tools.
 - Can accommodate two Hot Files, HAEHF, side-by-side.
 - 42 lb. storage capacity based on BIFMA loading standards.
- ⓘ Workplace Tools trays will not fit in cubby.

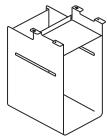

HAUFO15N
Undermount Open Cubby

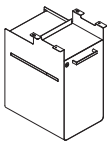
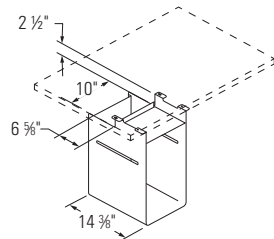

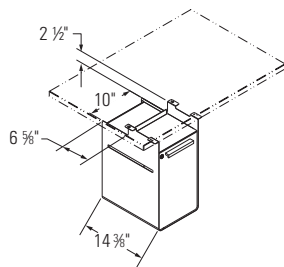

HAUFHR15N
Undermount Storage Cubby
with Locking Door

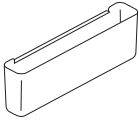

HOW TO SPECIFY

<p>Select Model Number</p> <p>HAUFO15N .</p>	<p>Select Case Color</p> <p>See page 662 P2 upcharge (+ \$18) P3 upcharge (+ \$40)</p> <p>P .</p>	<p>Select Door Color</p> <p>See page 662 P2 upcharge (+ \$18) P3 upcharge (+ \$40)</p> <p>S .</p>	<p>Select Lock Option</p> <p>L Standard Lock X Omit Lock (deduct \$20)</p> <p>L</p>
---	--	--	--

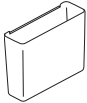
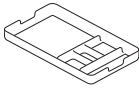
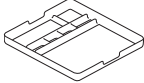
	DESCRIPTION	MODEL	SHIP WEIGHT	CUBE	LIST PRICE
	Side Saddle 12¼"W x 2½"D x 4"H	HAESS	0.6	0.1	\$36
	Hook 1⅝"W x 2¼"D x 3¼"H	HAECBH	0.1	0.1	\$24
	Hot File 12¼"W x 3⅞"D x 9½"H	HAEHF	0.7	1.5	\$54
	Slim Tray 8½"W x 14⅞"D x 1½"H	HAEST	1.0	0.2	\$48
	Large Tray 13½"W x 14⅞"D x 1½"H	HAELT	1.5	0.2	\$54

NOTES:

- Side Saddle and Hot File work on Paper Management Support Bars on page 429.
- Hook weight limit 20 lbs.

HOW TO SPECIFY

Select Model Number	Select Color
HAESS.	DW Designer White

400 SERIES



400 Series Lateral Files.

STORAGE

400 SERIES

Economical 400 Series lateral files from HON offer features not often found on competitors' files, such as a tamper-resistant enclosed base and factory-installed counterweights on two- and four-drawer cabinets to stabilize the center of gravity when a drawer is opened. Even the removable lock core system stands out among higher-priced rivals.



FEATURES

- Lateral files have counterweights for stability and a two-sided lock mechanism that resists tampering.
- Removable lock core can be changed as security needs require.
- Leveling glides compensate for uneven floors.
- Heavy-duty Steel ball-bearing drawer suspensions operate easily and quietly.
- Four vertical reinforcements keep the cabinet sturdy and the drawers gliding smoothly.
- Drawer handle design coordinates with HON Metro Classic Steel desks.

400 SERIES Lateral Files

OPEN MARKET

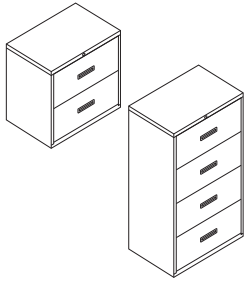

DESCRIPTION

Steel Lateral Files

- 30"W x 18"D x 28"H — 2 Drawer
- 30"W x 18"D x 53½"H — 4 Drawer
- 36"W x 18"D x 28"H — 2 Drawer
- 36"W x 18"D x 53½"H — 4 Drawer

NOTES: Drawers lock. Features ball-bearing slide suspensions.

MODEL	SHIP WEIGHT	CUBE	LIST PRICE
H432	109	12.4	\$627
H434	169	22.1	\$924
H482	124	12.4	\$655
H484	185	22.1	\$1055

STORAGE

NOTES:

- Reinforced case construction.
- Two adjustable leveling glides in front corners.
- Baked enamel finish.
- Monochromatic drawer pulls.
- **HON 5-Year Limited Warranty.**

HOW TO SPECIFY

Select
Model Number

H 4 3 2 .

Select
Lock Option

L Lock

L .

Select
Paint Color

- P Black
- Q Light Gray
- LOFT Loft
- L Putty

P .

VERTICAL FILES



310 Series Verticals with Perpetual® Seating.

STORAGE

VERTICAL FILES

Have lots to store but not a lot to spend? HON has a lot of filing solutions to fit your budget. Perfect for small businesses, home and professional offices, schools and more, HON's vertical files are value priced and available in multiple styles and sizes.



FEATURES

- Our vertical filing cabinets offer both legal and letter drawer sizes to accommodate all your filing needs.
- HON One Key core removable locks can be changed or interchanged as security demands change.
- Double-walled front kickplate stands up to impact.
- High drawer sides support hanging file folders, eliminating the need for extra-cost hangrails.

VERTICAL FILES ORDERING INFORMATION

210, 310, H320 & 510 VERTICAL FILES

PAINTS CODES

P1

- ◆ Black P
- ◆ Brownstone P7D
- ◆ Charcoal S
- ◆ Designer White PJW
- ◆ Fossil P28
- ◆ Greige T5
- ◆ Light Gray Q
- ◆ Loft LOFT
- ◆ Muslin T3
- ◆ Putty L
- ◆ Shadow SHDW
- ◆ Titanium P8T

P2

- ◆ Champagne Metallic T4
- ◆ Platinum Metallic T1

STORAGE

For Champagne Metallic Paint, Muslin is the suggested edgeband color.

◆◆◆ For lead time information see page 19.



Icon Legend on page 19

210 SERIES Vertical Files

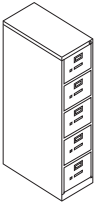
	DESCRIPTION	MODEL	SHIP WEIGHT	CUBE	LIST PRICE BY PAINT GRADE		
					P1	P2	P3
	Vertical File — 2 Drawer 15"W x 28½"D x 29"H, Letter 18¼"W x 28½"D x 29"H, Legal	H212 H212C	65 71	11.92 14.06	\$787 \$956	\$815 \$984	\$843 \$1012
	Vertical File — 4 Drawer 15"W x 28½"D x 52"H, Letter 18¼"W x 28½"D x 52"H, Legal	H214 H214C	114 123	19.64 23.18	\$1022 \$1214	\$1067 \$1259	\$1111 \$1303
	Vertical File — 5 Drawer 15"W x 28½"D x 60"H, Letter 18¼"W x 28½"D x 60"H, Legal	H215 H215C	136 145	22.31 26.33	\$1366 \$1623	\$1411 \$1668	\$1455 \$1712

STORAGE

NOTES:

- High capacity file, 28½" Case depth with 27 front-to-back filing inches per drawer.
- Letter or legal sizes available.
- Three-part, telescoping, steel ball-bearing suspension.
- Bright aluminum drawer pulls, label holders and thumb latch.
- Standard interchangeable core removable locks. Equipped with HON "One Key" system.
- Accepts hanging files. High drawer sides hold hanging file folders without use of hangrails.
- Spring loaded follower block with positive side-action positioning is adjustable on 5/8" centers.
- Baked enamel finish over rust-inhibiting phosphate pre-treatment.
- See page 677 for Vertical File Accessories.

ⓘ Keyed alike cores must be ordered separately — see page 853.

HOW TO SPECIFY

<p>Select Model Number</p> <p>H 2 1 2 .</p>	<p>Select Lock Option</p> <p>P Lock</p> <p>P .</p>	<p>Select Paint Color</p> <p>See page 672</p> <p>T 1</p>
--	---	---

310 SERIES Vertical Files

GSA SIN 33721



Icon Legend on page 19

STORAGE



DESCRIPTION

Vertical File — 2 Drawer
15"W x 26½"D x 29"H, Letter
18¼"W x 26½"D x 29"H, Legal

MODEL

H312
H312C

SHIP WEIGHT

60
66

CUBE

9.2
13.2

LIST PRICE BY PAINT GRADE

P1 P2 P3

\$477 \$505 \$533
\$605 \$633 \$661

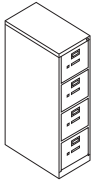

Vertical File — 4 Drawer
15"W x 26½"D x 52"H, Letter
18¼"W x 26½"D x 52"H, Legal

H314
H314C

107
116

16.03
21.76

\$648 \$693 \$737
\$792 \$837 \$881

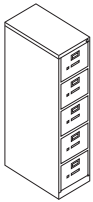

Vertical File — 5 Drawer
15"W x 26½"D x 60"H, Letter
18¼"W x 26½"D x 60"H, Legal

H315
H315C

128
137

20.94
24.72

\$951 \$996 \$1040
\$1131 \$1176 \$1220

NOTES:

- 26½" Case depth with 25 front-to-back filing inches per drawer.
- Letter or legal sizes available.
- Three-part, telescoping, steel ball-bearing suspension.
- Bright aluminum drawer pulls, label holders and thumb latch.
- Standard interchangeable core removable locks. Equipped with HON "One Key" system.
- Accepts hanging files. High drawer sides hold hanging file folders without use of hangrails.
- Spring loaded follower block with positive side-action positioning is adjustable on ⅝" centers.
- Baked enamel finish over rust-inhibiting phosphate pre-treatment.
- See page 677 for Vertical File Accessories.

! Keyed alike cores must be ordered separately — see page 853.

HOW TO SPECIFY

<p>Select Model Number</p> <p>H 3 1 2 .</p>	<p>Select Lock Option</p> <p>P Lock</p> <p>P .</p>	<p>Select Paint Color</p> <p>See page 672</p> <p>T 1</p>
--	---	---



Icon Legend on page 19

510 SERIES Vertical Files

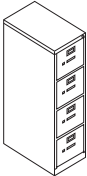
	DESCRIPTION	MODEL	SHIP WEIGHT	CUBE	LIST PRICE BY PAINT GRADE		
					P1	P2	P3
	Vertical File — 2 Drawer						
	15"W x 25"D x 29"H, Letter 18¼"W x 25"D x 29"H, Legal	H512	58	8.12	\$414	\$442	\$470
		H512C	63	9.71	\$531	\$559	\$587
	Vertical File — 4 Drawer						
	15"W x 25"D x 52"H, Letter 18¼"W x 25"D x 52"H, Legal	H514	102	17.42	\$559	\$604	\$648
		H514C	112	20.65	\$686	\$731	\$775

STORAGE

NOTES:

- 25" Case depth with 23½" front-to-back filing inches per drawer.
 - Letter and legal sizes are available.
 - Three-part telescoping, ball-bearing steel suspension.
 - Bright aluminum drawer pulls, label holders and thumb latch.
 - Standard interchangeable core removable locks. Equipped with HON "One Key" system.
 - Accepts hanging files. High drawer sides hold hanging file folders without use of hangrails.
 - Adjustable wire follower.
 - Baked enamel finish over rust-inhibiting phosphate pre-treatment.
- ! Keyed alike cores must be ordered separately — see page 853.

HOW TO SPECIFY

<p>Select Model Number</p> <p>H 5 1 2 .</p>	<p>Select Lock Option</p> <p>P Lock</p> <p>P .</p>	<p>Select Paint Color</p> <p>See page 672</p> <p>T 1</p>
--	---	---

LATERAL FILE ACCESSORIES

GSA SIN 33721



Icon Legend on page 19

STORAGE

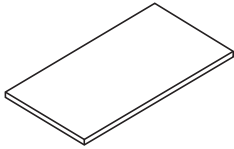

DESCRIPTION

Square Edge Laminate Top

- 30"W x 18"D x 1/8" Thick
- 36"W x 18"D x 1/8" Thick
- 42"W x 18"D x 1/8" Thick
- 60"W x 18"D x 1/8" Thick
- 66"W x 18"D x 1/8" Thick
- 72"W x 18"D x 1/8" Thick

MODEL

- H919430**
- H919436**
- H919442**
- H919460**
- H919466**
- H919472**

SHIP WEIGHT

- 20.0
- 25.0
- 30.0
- 32.0
- 40.0
- 48.0

CUBE

- 1.6
- 1.8
- 2.1
- 3.0
- 3.2
- 3.5

L1 LIST PRICE

- \$395**
- \$495**
- \$541**
- \$683**
- \$781**
- \$802**

L2 UPCHARGE

- \$10**
- \$10**
- \$10**
- \$15**
- \$15**
- \$15**

NOTES: Compatible with Flagship® and Brigade® 18"D Lateral Files only. Laminate tops are abrasion- and stain-resistant laminate.

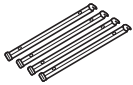

Single Rail Hanging File Racks (4/pack)

H919491

1.0

0.4

\$64

N/A

NOTES: For front-to-back filing — 30"W, 36"W and 42"W files. Order one package per drawer for 42"W files. One package will do two 30"W or 36"W file drawers. Racks span between 15 1/4"W rails. Hanging file racks and dividers available in Gray only.

Gray only.

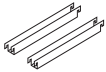

Double-Rail Hanging File Racks (2/pack)

H919492

1.5

0.4

\$64

N/A

NOTES: For 3 rows front-to-back — 42"W files. Order one package per drawer. Racks span between 15 1/4"W rails. Hanging file racks and dividers available in Gray only.

Gray only.

NOTES:

- Compatible with Flagship®, Brigade® 800, 700, 600, and 500 Series Lateral Files.

HOW TO SPECIFY

<p>Select Model Number</p> <p>H 9 1 9 4 3 0 .</p>	<p>Select Laminate</p> <p>See page 612</p> <p>N</p>
---	---

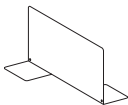

DESCRIPTION

Metal File Divider

- 10 pack
- 2 pack

MODEL

- HSCAFD10**
- HSCAFD02**

SHIP WEIGHT

- 12
- 3

CUBE

- 0.7
- 0.7



LIST PRICE

- \$199**
- \$52**

Metal dividers available in Black only. No need to specify.

VERTICAL FILE ACCESSORIES

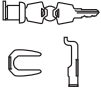
Icon Legend on page 19

	DESCRIPTION	MODEL	SHIP WEIGHT	CUBE	LIST PRICE
	Follower Block (4/pack)				
	Legal	HF60	8.0 	0.6	\$101
	Letter	HF50	7.0 	0.5	\$95
SIN 33721					
	Chrome Core Removable Lock Kit (Field installable)	HF24	0.2 	0.2	\$58
	Specify key number from 101E-225E. Lock info page 853.				
	Bulk Package — 6 HF24 Lock Kits (Individually shrink wrapped)	HF246	1.2 	0.2	\$270
	Lock info page 853.				
	OPEN MARKET				

STORAGE

HOW TO SPECIFY

Select Model Number

HF60

MOBILE PEDESTALS



Icon Legend on page 19

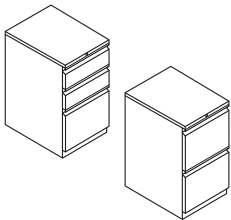

DESCRIPTION

Mobile Pedestal
15"W x 20"D x 28"H, Box/Box/File
15"W x 20"D x 28"H, File/File

MODEL SHIP WEIGHT CUBE LIST PRICE

HBMP2B	60	6.9	\$419
HBMP2F	60	6.9	\$419

STORAGE

NOTES:

- Pencil tray standard in top box drawer.
- One box divider standard in each box drawer.
- One crossrail standard in each file drawer.
- Ball-bearing suspension with 90% extension.
- Steel frame construction for everyday use.
- **HON 5-Year Limited Warranty.**

HOW TO SPECIFY

<p>Select Model Number</p> <p>H B M P 2 B .</p>	<p>Select Paint Color</p> <p>P Black Q Light Gray L Putty</p> <p>P</p>
--	---



Icon Legend on page 19

PEDESTAL ACCESSORIES

STORAGE

	DESCRIPTION	MODEL	SHIP WEIGHT	CUBE	LIST PRICE
	Counterweight — Freestanding Support Pedestals or Systems Support and Mobile Pedestals	HPCW1	18.0	0.1	\$195
	Follower Block — 1-Pack. Gray only.	HF80	1.0	0.3	\$49
	Double-Rail Hanging File Racks — 2-Pack. Gray only (for side-to-side).	H519495	0.5	0.5	\$33
	Adjustable Glides — 4-Pack Field-installable, used to convert mobile pedestals to freestanding support pedestals.	H20040AG	1.0	0.6	\$62
	NOTES: Hardware included. Compatible with Contain®.				
	Caster Package — Field Installable Four Casters (2 swivel, 2 fixed)	H1050CST	1.0	0.6	\$44
	NOTES: Used to convert Freestanding Support Pedestals to Mobile Pedestals. Does not work on Contain® or Flagship® B/F mobile pedestals. Not designed to be used on pedestals without a counterweight.				
	Lock Core Replacement Kit — Chrome (Specify quantity of each key number from 101E-225E.) Contains one core, two keys, one core removable tool and instructions. Refer to page 853.	HF23C	0.1	0.1	\$42
	SIN 33721 Master Key (one key) — Available to authorized dealers only.	HF22	0.1	0.1	\$25
	OPEN MARKET				

NOTES:

- Compatible with Flagship®, Brigade® and Systems Support Pedestals.

HOW TO SPECIFY

Select Model Number

HF23C

	DESCRIPTION	MODEL	SHIP WEIGHT	CUBE	FABRIC PRICE CODES																												
<p>OPEN MARKET</p>	Pedestal Seat 15"W x 18"D x 2"H NOTES: For seating fabrics, see pages 22-24. Works with Contain® and Flagship® Pedestals.	HPSEAT18ND	16.3	0.9	<table border="0"> <tr><td>1</td><td>\$165</td><td>8</td><td>\$361</td></tr> <tr><td>2</td><td>\$189</td><td>9</td><td>\$392</td></tr> <tr><td>3</td><td>\$213</td><td>10</td><td>\$423</td></tr> <tr><td>4</td><td>\$237</td><td>11</td><td>\$454</td></tr> <tr><td>5</td><td>\$268</td><td>12</td><td>\$485</td></tr> <tr><td>6</td><td>\$299</td><td>L</td><td>—</td></tr> <tr><td>7</td><td>\$330</td><td></td><td></td></tr> </table>	1	\$165	8	\$361	2	\$189	9	\$392	3	\$213	10	\$423	4	\$237	11	\$454	5	\$268	12	\$485	6	\$299	L	—	7	\$330		
	1	\$165	8	\$361																													
2	\$189	9	\$392																														
3	\$213	10	\$423																														
4	\$237	11	\$454																														
5	\$268	12	\$485																														
6	\$299	L	—																														
7	\$330																																
<p>OPEN MARKET</p>	Pedestal Seat 15"W x 22 7/8"D x 2"H NOTES: For seating fabrics, see pages 22-24. Works with Contain® and Flagship® Pedestals.	HPSEAT24ND	10.0	1.2	<table border="0"> <tr><td>1</td><td>\$194</td><td>8</td><td>\$390</td></tr> <tr><td>2</td><td>\$218</td><td>9</td><td>\$421</td></tr> <tr><td>3</td><td>\$242</td><td>10</td><td>\$452</td></tr> <tr><td>4</td><td>\$266</td><td>11</td><td>\$483</td></tr> <tr><td>5</td><td>\$297</td><td>12</td><td>\$514</td></tr> <tr><td>6</td><td>\$328</td><td>L</td><td>—</td></tr> <tr><td>7</td><td>\$359</td><td></td><td></td></tr> </table>	1	\$194	8	\$390	2	\$218	9	\$421	3	\$242	10	\$452	4	\$266	11	\$483	5	\$297	12	\$514	6	\$328	L	—	7	\$359		
	1	\$194	8	\$390																													
2	\$218	9	\$421																														
3	\$242	10	\$452																														
4	\$266	11	\$483																														
5	\$297	12	\$514																														
6	\$328	L	—																														
7	\$359																																

HOW TO SPECIFY

Select Model Number

Select Fabric

See pages 22-24 for seating fabric options

HPSEAT24 . APN23

PEDESTAL ACCESSORIES

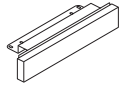

DESCRIPTION

Flush Front Kick Plate
For 28"H Flagship® Pedestals

MODEL	SHIP WEIGHT	CUBE	LIST PRICE BY PAINT GRADE		
			P1	P2	P3
HKP2800	3 Ⓞ	0.2	\$112	\$120	\$125

NOTES:

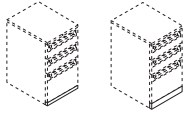

- Mounts to base of pedestal to provide a flush appearance to coordinate with laterals, file centers and storage towers.
- Kick plate is field-installable.

DESCRIPTION

Optional Pencil Tray

NOTES: For additional information see page 846.

- ⓘ For use with mobile and freestanding pedestal models.
- ⓘ No specification required.

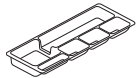

MODEL	SHIP WEIGHT	CUBE	LIST PRICE
HV-UT1	0.5	0.1	\$66

HOW TO SPECIFY

Select Model Number HKP2800	Select Paint Color See page 612 P
---------------------------------------	--

LAMINATE BOOKCASES

1870 Series Bookcases.



LAMINATE BOOKCASES

These sturdy laminate bookcases coordinate with most HON laminate desks. The scratch-, spill- and stain-resistant laminate will ensure that they keep their good looks.

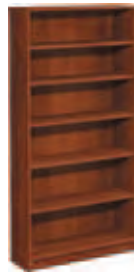

1870 SERIES FEATURES

- Shelves adjust on 1/4" increments.
- Leveling glides keep them nicely aligned, even if the floor isn't.
- Easy to assemble, using high-precision cam-locks and wood dowels, with no glue needed.

10500 SERIES FEATURES

- Ship fully assembled and ready to use.
- Adjustable leveling glides compensate for uneven floors.
- Available in a broad palette of laminate colors.



BOOKCASES ORDERING INFORMATION

10500 SERIES™ BOOKCASES

L1 LAMINATES CODES

Woodgrain

- ◆ Bourbon Cherry H
- ◆ Cognac COGN
- ◆ Florence Walnut LFW1
- ◆ Harvest C
- ◆ Kingswood Walnut LK11
- ◆ Mahogany N
- ◆ Mocha MOCH
- ◆ Natural Maple D
- ◆ Pinnacle PINC
- ◆ Shaker Cherry F

Solid

- ◆ Black P
- ◆ Charcoal S
- ◆ Designer White LDW1
- ◆ Loft LOFT

Patterned Top*

- ◆ Sheer Mesh A5
- ◆ Silver Mesh B9
- ◆ Canyon Zephyr K9
- ◆ Desert Zephyr K8
- ◆ Grey Tigris L6

L2 LAMINATES CODES

Woodgrain

- ◆ Lowell Ash LLA1
- ◆ Natural Recon LNR1
- ◆ Phantom Ecru LPE1
- ◆ Portico Teak LPT1
- ◆ Skyline Walnut LSW1

1870 SERIES BOOKCASES

L1 LAMINATES CODES

Woodgrain

- ◆ Cognac COGN
- ◆ Harvest C
- ◆ Mahogany N

* NOTE: For patterned top laminates, select one of the following for the edgeband around the top, the shelves and vertical panels — Black (P), Bourbon Cherry (H), Designer White (DW), Charcoal (S), Cognac (COGN), Harvest (C), Mahogany (N), Mocha (MOCH), Natural Maple (D), Pinnacle (PINC), Shaker Cherry (F).

◆◆◆ For lead time information see page 19.



10500 SERIES™ Laminate Bookcases

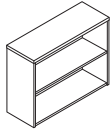

DESCRIPTION

Laminate Bookcase

- 36"W x 13 1/8"D x 29 3/8"H, 2-Shelf
- 36"W x 13 1/8"D x 43 3/8"H, 3-Shelf
- 36"W x 13 1/8"D x 57 1/8"H, 4-Shelf
- 36"W x 13 1/8"D x 71"H, 5-Shelf

MODEL	SHIP WEIGHT	CUBE	L1 LIST PRICE	L2 LIST PRICE
H105532	90	11.0	\$474	\$489
H105533	122	15.6	\$602	\$622
H105534	156	20.2	\$710	\$735
H105535	187	25.1	\$825	\$855

NOTES: Ships fully assembled. Fixed shelves. Inside shelf dimensions on all units are 33 1/4"W x 11 1/4"D x 12 1/4"H.

10500 Series™ Laminate Bookcases

- Available Laminate Colors:

Woodgrain	Solid	Patterned Top*	Two-Tone (Top/Chassis)
<p><i>L1 Laminates:</i> Bourbon Cherry (HH) Cognac (COGNCOGN) Harvest (CC) Mahogany (NN) Mocha (MOCHMOCH) Natural Maple (DD) Pinnacle (PINCPINC) Shaker Cherry (FF)</p> <p><i>L2 Laminates:</i> Lowell Ash (LLA1) Natural Recon (LNR1) Phantom Ecru (LPE1) Portico Teak (LPT1) Skyline Walnut (LSW1)</p>	<p>Black (PP) Charcoal (SS) Designer White (LDWILDW1) Loft (LOFTLOFT)</p>	<p>Canyon Zephyr (K9) Desert Zephyr (K8) Grey Tigris (L6) Sheer Mesh (A5) Silver Mesh (B9)</p> <p>*Patterned Laminates are available with the following chassis/edgebanding laminate selection: Black (P) Bourbon Cherry (H) Charcoal (S) Designer White (LDW1) Harvest (CC) Loft (LOFT) Mahogany (N) Natural Maple (D) Shaker Cherry (F)</p> <p>Edgebanding around top will match chassis laminate color selected.</p>	<p>Top and edgebanding are the same, chassis is different laminate color:</p> <p>Black/Charcoal (PS) Black/Designer White (PLDW1) Black/Loft (PLOFT) Bourbon Cherry/Black (HP) Bourbon Cherry/Charcoal (HS) Bourbon Cherry/Designer White (HLDW1) Bourbon Cherry/Loft (HLOFT) Charcoal/Black (SP) Charcoal/Designer White (SLDW1) Cognac/Black (COGNP) Cognac/Charcoal (COGNS) Cognac/Designer White (COGNLDW1) Cognac/Loft (COGNLOFT) Designer White/Black (LDWIP) Designer White/Bourbon Cherry (LDWIH) Designer White/Charcoal (LDWIS) Designer White/Cognac (LDWICOGN) Designer White/Harvest (LDWIC) Designer White/Loft (LDWILOFT) Designer White/Lowell Ash (LDWILLA10) Designer White/Mahogany (LDWIN) Designer White/Mocha (LDWIMUCH) Designer White/Natural Maple (LDWID) Designer White/Natural Recon (LDWILNR1) Designer White/Phantom Ecru (LDWILPE1) Designer White/Pinnacle (LDWIPINC) Designer White/Portico Teak (LDWILPTI) Designer White/Shaker Cherry (LDWIF) Designer White/Skyline Walnut (LDWILSW1) Harvest/Black (CP) Harvest/Charcoal (CS) Harvest/Designer White (CLDW1) Harvest/Loft (CLOFT) Loft/Black (LOFTP) Loft/Charcoal (LOFTS) Loft/Designer White (LOFTLDW1) Lowell Ash/Black (LLAIP) Lowell Ash/Charcoal (LLA1S) Lowell Ash/Designer White (LLA1LDW1) Lowell Ash/Loft (LLA1LOFT)</p> <p>Mahogany/Black (NP) Mahogany/Charcoal (NS) Mahogany/Designer White (NLDW1) Mahogany/Loft (NLOFT) Mocha/Black (MOCHP) Mocha/Charcoal (MOCHS) Mocha/Designer White (MOCHLDW1) Mocha/Loft (MOCHLOFT) Natural Maple/Black (DP) Natural Maple/Charcoal (DS) Natural Maple/Designer White (DLDW1) Natural Maple/Loft (DLOFT) Natural Recon/Black (LNRIP) Natural Recon/Charcoal (LNRIS) Natural Recon/Designer White (LNR1LDW1) Natural Recon/Loft (LNR1LOFT) Phantom Ecru/Black (LPEIP) Phantom Ecru/Charcoal (LPEIS) Phantom Ecru/Designer White (LPE1LDW1) Phantom Ecru/Loft (LPE1LOFT) Pinnacle/Black (PINCP) Pinnacle/Charcoal (PINCS) Pinnacle/Designer White (PINCLDW1) Pinnacle/Loft (PINCLLOFT) Portico Teak/Black (LPTIP) Portico Teak/Charcoal (LPTIS) Portico Teak/Designer White (LPT1LDW1) Portico Teak/Loft (LPT1LOFT) Shaker Cherry/Black (FP) Shaker Cherry/Charcoal (FS) Shaker Cherry/Designer White (FLDW1) Shaker Cherry/Loft (FLOFT) Skyline Walnut/Black (LSWIP) Skyline Walnut/Charcoal (LSWIS) Skyline Walnut/Designer White (LSW1LDW1) Skyline Walnut/Loft (LSW1LOFT)</p>

Patterned Top

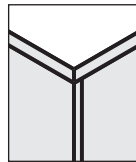
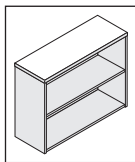

Edgeband Around Top/Laminate Base

Two-Tone Laminate Top/Edgebanding

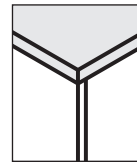
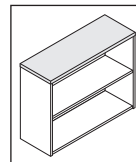

Laminate Base

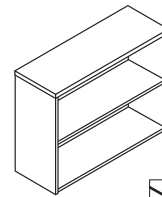

Square Corner Edge Detail



NOTES:

- 10500 Series™ Casegoods smooth, flat edge detail (see pages 244-288) complements many furniture designs.
- Fully finished back.
- Replaces 1980 Series Laminate Bookcases.

- Bottom shelf, top and end panels are 1 1/8" thick. Interior shelves are 3/4" thick.
- All surfaces finished in abrasion- and stain-resistant thermal-fused laminate over solid core high-performance particleboard.
- Adjustable hex leveling glides allow floor-standing bookcases to be easily leveled without lifting the unit; glides have 3/4" adjustable range.

HOW TO SPECIFY

<p>Select Model Number</p> <p>H 1 0 5 5 3 2 .</p>	<p>Select Laminate</p> <p>See page 682</p> <p>N N</p>
---	---

1870 SERIES Laminate Bookcases

GSA SIN 33721



Icon Legend on page 19

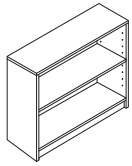

DESCRIPTION

Laminate Bookcase

- 36"W x 11½"D x 29⅞"H, 2-Shelf (1 adjustable)
- 36"W x 11½"D x 36⅞"H, 3-Shelf (2 adjustable)
- 36"W x 11½"D x 48¾"H, 4-Shelf (3 adjustable)
- 36"W x 11½"D x 60⅞"H, 5-Shelf (3 adjustable)
- 36"W x 11½"D x 72⅝"H, 6-Shelf (4 adjustable)
- 36"W x 11½"D x 84"H, 6-Shelf (4 adjustable)

MODEL

SHIP WEIGHT

CUBE

LIST PRICE

H1871	48	1.5	\$249
H1872	60	1.7	\$276
H1874	77	2.6	\$334
H1875	92	2.8	\$392
H1876	109	3.4	\$450
H1877	124	4.5	\$511

Set of doors with hinges used to conceal lower shelf contents
36"W x 25¾"H

H1801

23 **Ⓢ**

1.0

\$206

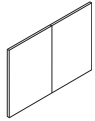

STORAGE

NOTES:

- Square edge profile complements many different furniture designs.
- Abrasion- and stain-resistant laminate, over durable solid core, high-performance particleboard.
- ¾" thick shelves adjust in ¼" increments to suit a variety of storage needs (two shelves are fixed in 5- and 6-shelf units).
- Cam-lock fasteners and wood dowels ensure pieces go together easily and precisely.
- Equipped with four adjustable leveling glides.
- Shelves will deflect under large amounts of weight.
- ⅝" hardboard back panel.
- All bookcases are 36"W x 11½"D.
- Optional doors available to conceal lower shelf contents.
- Choose from Harvest or Mahogany.
- Easy-to-assemble instructions included.

! Designed to be used in small office-home office applications.

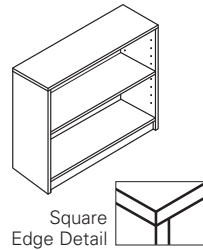

Square Edge Detail

HOW TO SPECIFY

Select Model Number

Select Laminate

- COGN** Cognac
- C** Harvest
- N** Mahogany

H 1 8 7 1 .

N

ARRANGE®



Arrange® Tables shown with Flock® Seating.

TABLES

ARRANGE®

Non-traditional workspace? Transform it with Arrange tables. Ideal for cafés and other collaborative spaces, Arrange tables are available in seated, counter and standing-heights, and can accommodate anywhere from two to eight people. With four tabletop shapes and more than 40 different finish options, you can create a unique and usable space that brings people together.



FEATURES

- Simple, clean design coordinates nicely with other HON furniture.
- The traditional x-base can be updated with a disc shroud.
- Tables come with optional cord grommets and outlets to accommodate a wide range of technical needs — or none at all.
- Aluminum bases are durable, long-lasting and lightweight, making it easy to move and rearrange floor plans.
- Laminate surfaces are durable and resist scratches, spills and stains.

ARRANGE® CAFÉ TABLES ORDERING INFORMATION

TABLES

LAMINATE

TOPS/L1 LAMINATES CODES

Woodgrain

- ◆ Bourbon Cherry **H**
- ◆ Cognac **COGN**
- ◆ Florence Walnut **LFW1**
- ◆ Harvest **C**
- ◆ Kingswood Walnut **LKI1**
- ◆ Mahogany **N**
- ◆ Mocha **MOCH**
- ◆ Natural Maple **D**
- ◆ Pinnacle **PINC**
- ◆ Shaker Cherry **F**
- ◆ Sterling Ash **LSA1**

Solid

- ◆ Black **P**
- ◆ Charcoal **S**
- ◆ Designer White **LDW1**
- ◆ Loft **LOFT**

Patterned

- ◆ Sheer Mesh **A5**
- ◆ Silver Mesh **B9**
- ◆ Steel Mesh **A9**
- ◆ Canyon Zephyr **K9**
- ◆ Desert Zephyr **K8**
- ◆ Shadow Zephyr **K1**
- ◆ Gray **G2**
- ◆ Grey Tigris **L6**
- ◆ White **G1**
- ◆ Whitestone **K4**

TOPS/L2 LAMINATES CODES

Woodgrain

- ◆ Lowell Ash **LLA1**
- ◆ Natural Recon **LNR1**
- ◆ Phantom Ecu **LPE1**
- ◆ Portico Teak **LPT1**
- ◆ Skyline Walnut **LSW1**

PAINT

PAINT CODES

P1

- ◆ Textured Black **BLCK**
- ◆ Textured Brownstone **P7J**
- ◆ Textured Charcoal **P7A**
- ◆ Textured Designer White ... **PK7**
- ◆ Textured Loft **P7L**
- ◆ Textured Muslin **P7M**
- ◆ Textured Titanium **P8V**

P2

- ◆ Solar Black **P8X**
- ◆ Textured Platinum
Metallic **PLAT**
- ◆ Textured Silver **PR8**

EDGE BAND

EDGE BAND CODES

- ◆ Black **P**
- ◆ Bourbon Cherry **H**
- ◆ Charcoal **S**
- ◆ Cognac **COGN**
- ◆ Designer White **DW**
- ◆ Florence Walnut **FW**
- ◆ Greige **R**
- ◆ Harvest **C**
- ◆ Kingswood Walnut **KI**
- ◆ Loft **LOFT**
- ◆ Lowell Ash **DL**
- ◆ Mahogany **N**
- ◆ Mocha **MOCH**
- ◆ Muslin **T**
- ◆ Natural Maple **D**
- ◆ Natural Recon **NR**
- ◆ Phantom Ecu **PE**
- ◆ Pinnacle **PINC**
- ◆ Platinum **K**
- ◆ Portico Teak **DP**
- ◆ Shadow * **SHDW**
- ◆ Shaker Cherry **F**
- ◆ Skyline Walnut **SW**
- ◆ Sterling Ash **SA**

Recommended Edgeband Color Selection:

Laminate		Edgeband	
Bourbon Cherry	H	Bourbon Cherry	H
Cognac	COGN	Cognac	COGN
Florence Walnut	LFW1	Florence Walnut	FW
Grey Tigris	L6	Greige	R
Harvest	C	Harvest	C
Kingswood Walnut	LKI1	Kingswood Walnut	KI
Mahogany	N	Mahogany	N
Mocha	MOCH	Mocha	MOCH
Natural Maple	D	Natural Maple	D
Pinnacle	PINC	Pinnacle	PINC
Shaker Cherry	F	Shaker Cherry	F
Sterling Ash	LSA1	Sterling Ash	SA
Black	P	Black	P
Charcoal	S	Charcoal	S
Designer White	LDW1	Designer White	DW
Whitestone	K4	Muslin	T
Sheer Mesh	A5	Muslin	T
Silver Mesh	B9	Loft	LOFT
Steel Mesh	A9	Charcoal	S
Canyon Zephyr	K9	Greige	R
Desert Zephyr	K8	Greige	R
Shadow Zephyr	K1	Loft	LOFT
Lowell Ash	LLA1	Lowell Ash	DL
Natural Recon	LNR1	Natural Recon	NR
Phantom Ecu	LPE1	Phantom Ecu	PE
Portico Teak	LPT1	Portico Teak	DP
Skyline Walnut	LSW1	Skyline Walnut	SW
Loft	LOFT	Loft	LOFT



◆◆◆ For lead time information see page 19.

* De-emphasized

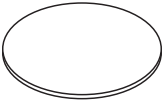

Icon Legend on page 19

ARRANGE[®] Café Table Tops

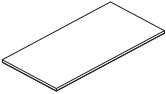
	DESCRIPTION	MODEL	SHIP WEIGHT	CUBE	LIST PRICE BY LAMINATE GRADE	
					L1	L2
	Café Round Table Tops					
	24"W Round Top	HCTRND24	19	1.9	\$313	\$328
	30"W Round Top	HCTRND30	31	2.9	\$337	\$352
	36"W Round Top	HCTRND36	44	4.0	\$367	\$382
	42"W Round Top	HCTRND42	57	5.4	\$435	\$455
	48"W Round Top	HCTRND48	71	7.2	\$474	\$494
	Square Table Tops					
	24"W Square Top	HCTSQR24	19	2.2	\$298	\$313
	30"W Square Top	HCTSQR30	31	2.9	\$321	\$336
	36"W Square Top	HCTSQR36	44	4.1	\$350	\$365
	42"W Square Top	HCTSQR42	57	5.6	\$416	\$436
	Soft Square Table Tops					
	24"W Soft Square Top	HCTSFT24	19	1.9	\$313	\$328
	30"W Soft Square Top	HCTSFT30	31	2.9	\$337	\$352
	36"W Soft Square Top	HCTSFT36	44	4.0	\$367	\$382
	42"W Soft Square Top	HCTSFT42	57	5.4	\$435	\$455
	48"W Soft Square Top	HCTSFT48	71	7.2	\$474	\$494
	Rectangle Table Tops					
	24"W x 48"D Rectangle Top	HCTRECT2448	36	3.6	\$355	\$370
	24"W x 60"D Rectangle Top	HCTRECT2460	44	4.4	\$389	\$404
	24"W x 72"D Rectangle Top	HCTRECT2472	56	4.9	\$412	\$432
	30"W x 48"D Rectangle Top	HCTRECT3048	51	4.4	\$367	\$382
	30"W x 60"D Rectangle Top	HCTRECT3060	63	5.4	\$412	\$427
	30"W x 72"D Rectangle Top	HCTRECT3072	75	6.0	\$457	\$477

TABLES

NOTES:

- 2 grommet cutouts on Rectangles which will be positioned over the installed bases.

HOW TO SPECIFY

<p>Select Model Number</p> <p>H C T R N D 2 4 .</p>	<p>Select Grommet Option</p> <p>G Round Grommet (\$15 upcharge) N No Grommet Upcharge doubles for HCTRECT models</p> <p>G .</p>	<p>Select Laminate</p> <p>See page 686</p> <p>C .</p>	<p>Select Edge Color</p> <p>See page 686</p> <p>C</p>
--	--	--	--

ARRANGE[®] Café Table Bases

GSA SIN 33721



Icon Legend on page 19

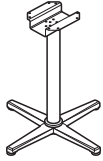

DESCRIPTION

Café Table Bases — X-Base

Seated Height X-base for 24"-30"D Surfaces
Seated Height X-base for 36"D Surfaces
Seated Height X-base for 42"-48"D Surfaces

MODEL	SHIP WEIGHT	CUBE	LIST PRICE	P2 UPCHARGE
HCT29SX	22	3.3	\$475	\$20
HCT29MX	23	3.3	\$528	\$20
HCT29LX	25	3.3	\$580	\$20
HCT36SX	24	4.6	\$528	\$20
HCT36MX	25	4.6	\$580	\$20
HCT36LX	27	4.6	\$633	\$20
HCT42SX	25	4.6	\$580	\$20
HCT42MX	26	4.6	\$633	\$20
HCT42LX	27	4.6	\$685	\$20

Counter-Height X-base for 24"-30"D Surfaces
Counter-Height X-base for 36"D Surfaces
Counter-Height X-base for 42"-48"D Surfaces

Café-Height X-base for 24"-30"D Surfaces
Café-Height X-base for 36"D Surfaces
Café-Height X-base for 42"-48"D Surfaces

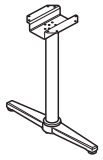

Café Table Bases — T-Leg Base

Seated Height T-legs for 24"D Surfaces (2 bases incl.)
Seated Height T-legs for 30"D Surfaces (2 bases incl.)

Counter-Height T-legs for 24"D Surfaces (2 bases incl.)
Counter-Height T-legs for 30"D Surfaces (2 bases incl.)

Café-Height T-legs for 24"D Surfaces (2 bases incl.)
Café-Height T-legs for 30"D Surfaces (2 bases incl.)

HCT29ST	33	3.3	\$644	\$20
HCT29MT	34	3.3	\$717	\$20
HCT36ST	36	4.6	\$693	\$20
HCT36MT	37	4.6	\$747	\$20
HCT42ST	37	4.6	\$742	\$20
HCT42MT	38	4.6	\$797	\$20

NOTES:

- Wire management is standard through table column.
- Adjustable glides available on all feet.





HOW TO SPECIFY

Select Model Number HCT29SX	Select Paint Color See page 686 BLCK
---------------------------------------	---

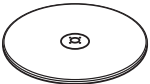

Icon Legend on page 19

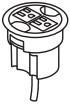
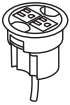
ARRANGE[®] Café Accessories

	DESCRIPTION	MODEL	SHIP WEIGHT	CUBE	LIST PRICE
 SIN 33721 	Café Table Bases — Disc Shroud Small Disc Shroud for bases that support 24"-30" Surfaces Medium Disc Shroud for bases that support 36" Surfaces Large Disc Shroud for bases that support 42"-48" Surfaces	HCTSDS HCTMDS HCTLDS	9.0 12.0 17.0	2.0 2.4 3.4	\$94 \$108 \$125
	NOTES: Shroud is used as an optional accessory to provide the aesthetic of a disc base. Shroud can be added to existing X-base configurations to provide a new and updated aesthetic. Shroud is made of 18 gauge steel.				
	! Shroud to be used in conjunction with X-bases only and cannot be used with a T-leg configuration.				
	! Shroud cannot be used as a support piece by itself.				
	Power Hub, 3" Grommet Mount, 6' Cord	HGRMTAC	1.3	0.2	\$111
	NOTES: For additional information see page 848. ! Available in black only (no color designation so use .X - Specify: HGRMTAC.X).				
 	Power Hub, 3" Grommet Mount, 10' Cord	HGRMTAC2	1.5	0.2	\$148
	NOTES: For additional information see page 848. ! Available in black finish only, no specification needed.				

TABLES

NOTES:

! HGRMTUSB2 is not compatible with Arrange[®] bases.

HOW TO SPECIFY

<p>Select Model Number</p>	<p>Select Paint Color</p> <p><i>For HCTSDS, HCTMDS and HCTLDS models only</i></p> <p>See page 686</p>
<div style="display: flex; gap: 5px;"> <div style="border: 1px solid black; padding: 2px;">H</div> <div style="border: 1px solid black; padding: 2px;">C</div> <div style="border: 1px solid black; padding: 2px;">T</div> <div style="border: 1px solid black; padding: 2px;">S</div> <div style="border: 1px solid black; padding: 2px;">D</div> <div style="border: 1px solid black; padding: 2px;">S</div> </div>	<div style="display: flex; gap: 5px;"> <div style="border: 1px solid black; padding: 2px;">B</div> <div style="border: 1px solid black; padding: 2px;">L</div> <div style="border: 1px solid black; padding: 2px;">C</div> <div style="border: 1px solid black; padding: 2px;">K</div> </div>

BETWEEN™ TABLES

TABLES



Between™ Tables shown with Ignition® ReActiv® Back Seating.

BETWEEN™ TABLES

The rise of mobile workers. Increased desire for socialization. Escalating real estate costs. These trends are driving inventive ways of getting the job done. This new approach requires getting the most out of every inch of space by adding versatile tables that add value and increase productivity. Whether you're working here, there or anywhere Between, this table collection's got you covered.



FEATURES

- Choose from round, square and soft square tops.
- 1/8" thick worksurface provides a sturdy foundation for work.
- Scratch-, spill- and stain-resistant laminate stands up to heavy use.
- Easily attach a base using pre-drilled holes.

BETWEEN™ ORDERING INFORMATION

LAMINATE

TOPS/L1 LAMINATES CODES

Woodgrain

- ◆ Bourbon Cherry H
- ◆ Cognac COGN
- ◆ Florence Walnut LFW1
- ◆ Harvest C
- ◆ Kingswood Walnut LK11
- ◆ Mahogany N
- ◆ Mocha MOCH
- ◆ Natural Maple D
- ◆ Pinnacle PINC
- ◆ Shaker Cherry F
- ◆ Sterling Ash LSA1

Solid

- ◆ Black P
- ◆ Charcoal S
- ◆ Designer White LDW1
- ◆ Loft LOFT

Patterned

- ◆ Sheer Mesh A5
- ◆ Silver Mesh B9
- ◆ Steel Mesh A9
- ◇ Canyon Zephyr K9
- ◇ Desert Zephyr K8
- ◇ Shadow Zephyr K1
- ◇ Whitestone K4

TOPS/L2 LAMINATES CODES

Woodgrain

- ◆ Lowell Ash LLA1
- ◆ Natural Recon LNRI
- ◆ Phantom Ecru LPE1
- ◆ Portico Teak LPT1
- ◆ Skyline Walnut LSW1

PAINT

PAINT CODES

P1

- ◆ Black P71
- ◆ Black Mica Texture P6P
- ◆ Brownstone P7D
- ◆ Charcoal P02
- ◆ Designer White PJW
- ◆ Fossil P28
- ◆ Greige T5
- ◆ Loft LOFT
- ◆ Muslin T3
- ◆ Textured Brownstone P7J
- ◆ Textured Charcoal P7A
- ◆ Textured Designer White ... PK7
- ◆ Textured Loft P7L
- ◆ Textured Muslin P7M
- ◆ Textured Titanium P8V
- ◆ Titanium P8T

P2

- ◆ Silver PR6
- ◆ Textured Silver PR8

EDGE BAND

EDGE BAND CODES

- ◆ Black P
- ◆ Bourbon Cherry H
- ◆ Charcoal S
- ◆ Cognac COGN
- ◆ Designer White DW
- ◆ Florence Walnut FW
- ◇ Greige R
- ◆ Harvest C
- ◆ Kingswood Walnut KI
- ◆ Loft LOFT
- ◆ Lowell Ash DL
- ◆ Mahogany N
- ◆ Mocha MOCH
- ◇ Muslin T
- ◆ Natural Maple D
- ◆ Natural Recon NR
- ◆ Phantom Ecru PE
- ◆ Pinnacle PINC
- ◆ Platinum K
- ◆ Portico Teak DP
- ◇ Shadow SHDW
- ◆ Shaker Cherry F
- ◆ Skyline Walnut SW
- ◆ Sterling Ash SA

Recommended Edgeband Color Selection:

Laminate		Edgeband	
Bourbon Cherry	H	Bourbon Cherry	H
Cognac	COGN	Cognac	COGN
Florence Walnut	LFW1	Florence Walnut	FW
Harvest	C	Harvest	C
Kingswood Walnut	LK11	Kingswood Walnut	KI
Mahogany	N	Mahogany	N
Mocha	MOCH	Mocha	MOCH
Natural Maple	D	Natural Maple	D
Pinnacle	PINC	Pinnacle	PINC
Shaker Cherry	F	Shaker Cherry	F
Sterling Ash	LSA1	Sterling Ash	SA
Black	P	Black	P
Charcoal	S	Charcoal	S
Designer White	LDW1	Designer White	DW
Whitestone	K4	Muslin	T
Sheer Mesh	A5	Muslin	T
Silver Mesh	B9	Loft	LOFT
Steel Mesh	A9	Charcoal	S
Canyon Zephyr	K9	Greige	R
Desert Zephyr	K8	Greige	R
Shadow Zephyr	K1	Loft	LOFT
Lowell Ash	LLA1	Lowell Ash	DL
Natural Recon	LNRI	Natural Recon	NR
Phantom Ecru	LPE1	Phantom Ecru	PE
Portico Teak	LPT1	Portico Teak	DP
Skyline Walnut	LSW1	Skyline Walnut	SW
Loft	LOFT	Loft	LOFT

◆◆◆ For lead time information see page 19.

* De-emphasized

BETWEEN™ Table Tops

GSA SIN 33721

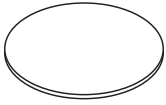
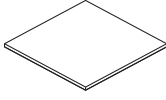
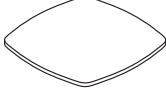

Icon Legend on page 19

	DESCRIPTION	MODEL	SHIP WEIGHT	CUBE	LIST PRICE BY LAMINATE GRADE	
					L1	L2
	Round Table Tops					
	30"W Round Top	HBTRND30	31	2.9	\$310	\$325
	36"W Round Top	HBTRND36	44	4.0	\$338	\$354
	42"W Round Top	HBTRND42	57	5.4	\$401	\$421
	Square Table Tops					
	30"W Square Top	HBTSQR30	31	2.9	\$295	\$309
	36"W Square Top	HBTSQR36	44	4.1	\$323	\$339
	42"W Square Top	HBTSQR42	57	5.6	\$383	\$402
	Soft Square Table Tops					
	30"W Soft Square Top	HBTSFT30	31	2.9	\$310	\$325
	36"W Soft Square Top	HBTSFT36	44	4.0	\$338	\$354
	42"W Soft Square Top	HBTSFT42	57	5.4	\$401	\$421

TABLES

HOW TO SPECIFY

Select Model Number HBTRND30	Select Grommet Option N No Grommet	Select Laminate See page 691 C	Select Edge Color See page 691 C
--	--	---	---

OPEN MARKET EXCEPT AS NOTED



Icon Legend on page 19

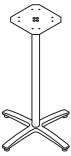

BETWEEN™ Table Bases

	DESCRIPTION	MODEL	SHIP WEIGHT	CUBE	LIST PRICE
	X-Base				
	Seated Height X-base for Support of 30", 36" Tops	HBTTX30S	27	5.2	\$298
	Seated Height X-base for Support of 42" Tops	HBTTX30L	29	5.2	\$437
	Standing-Height X-base for Support of 30", 36" Tops	HBTTX42S	30	5.2	\$359
	Standing-Height X-base for 42" Tops	HBTTX42L	34	5.2	\$500

SIN 33721

NOTES:

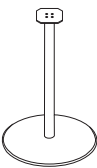
- Seated Height (30¾" to top of surface).
- Café-Height (42¼" to top of surface).
- Adjustable glides with ¼" adjustment available on all feet.

	Seated Height Disc Base ! Disc Base not for use with 42" square top.	HBTTD30	24	3.3	\$359
	Standing-Height Disc Base ! Disc Base not for use with 42" square top.	HBTTD42	27	3.3	\$424
	Counterweight Kit for Disc Base ! Required for use with 42" round and soft square tops. Optional for smaller top sizes.	HBTCW	16	0.2	\$142

NOTES:

- Seated Height (29" to top of surface).
- Café-Height (42" to top of surface).
- Counterweight Kit required when using disc base with 42" round or soft square tops. Kit can be used for added stability on 30" or 36" round, square, and soft square tops if desired.

HOW TO SPECIFY

<p>Select Model Number</p>	<p>Select Paint Color</p> <p>P7J Textured Brownstone P7A Textured Charcoal PK7 Textured Designer White P7L Textured Loft P7M Textured Muslin PR8 Textured Silver (\$20 upcharge) P8V Textured Titanium P6P Black Mica Texture</p>
<p>HBTTX30S</p>	<p>PR8</p>

TABLES

BETWEEN™ Rectangular Table Tops

OPEN MARKET



Icon Legend on page 19

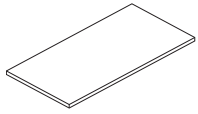

DESCRIPTION

Rectangular Table Tops

48"W x 24"D
60"W x 24"D
72"W x 24"D

MODEL

HMPTT2448
HMPTT2460
HMPTT2472

SHIP WEIGHT

45
57
68

CUBE

3.7
4.5
5.0

LIST PRICE BY LAMINATE GRADE

L1

\$342
\$379
\$419

L2

\$359
\$398
\$440

48"W x 30"D
60"W x 30"D
72"W x 30"D

HMPTT3048
HMPTT3060
HMPTT3072

57
71
85

4.4
5.4
6.0

\$357
\$391
\$446

\$375
\$411
\$468

NOTES:

- HON 5-Year Limited Warranty.

HOW TO SPECIFY

Select Model Number

H M P T T 2 4 4 8 .

Select Grommet Option

N No Grommet

N .

Select Laminate

See page 691

C .

Select Edge Color

See page 691

C .

TABLES

BETWEEN™ Table Bases for Rectangular Tops

OPEN MARKET



Icon Legend on page 19

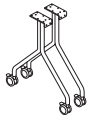

DESCRIPTION

Fixed Leg

MODEL

HMPTBFX

SHIP WEIGHT

27

CUBE

6.3

LIST PRICE

\$260

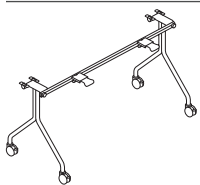

DESCRIPTION

Nesting Base

For use with 48"W Rectangular Tops
For use with 60"W and 72"W Rectangular Tops

MODEL

HMPTBNSS
HMPTBNSL

18
19

6.3
6.3

\$300
\$320

NOTES:

- Tops and bases ship in separate cartons.
- HON 5-Year Limited Warranty.

HOW TO SPECIFY

Select Model Number

H M P T B F X .

Select Paint Color

P71 Black
P7D Brownstone
P02 Charcoal
PJW Designer White
P28 Fossil
LOFT Loft
T3 Muslin
PR6 Silver (\$20 upcharge)
P8T Titanium

P 7 1



Icon Legend on page 19

BETWEEN™ Nesting Tables

	DESCRIPTION	MODEL	SHIP WEIGHT	CUBE	LIST PRICE
	Nesting Table				
	48"W x 24"D	HMPT2448NS	69	8.9	\$578
	60"W x 24"D	HMPT2460NS	81	10.7	\$629
	72"W x 24"D	HMPT2472NS	92	12.4	\$665
	48"W x 30"D	HMPT3048NS	81	10.9	\$591
	60"W x 30"D	HMPT3060NS	95	13.1	\$640
	72"W x 30"D	HMPT3072NS	109	15.0	\$689

NOTES:

- Top and base ship in one carton.
- Limited finishes available on single-carton tables.
- **HON 5-Year Limited Warranty.**

HOW TO SPECIFY

<p>Select Model Number</p> <p>HMPT2448NS</p>	<p>Select Grommet Option</p> <p>N No Grommet</p> <p>N</p>	<p>Select Laminate/Edge</p> <p>B9LOFT Silver Mesh/Loft Edge FF Shaker Cherry/Shaker Cherry Edge PINCINC Pinnacle/Pinnacle Edge</p> <p>B9LOFT</p>	<p>Select Base Paint</p> <p>P71 Black</p> <p>P71</p>
---	--	---	---

TABLES



Icon Legend on page 19

BETWEEN™ Shared Components

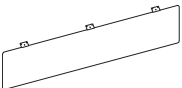
	DESCRIPTION	MODEL	SHIP WEIGHT	CUBE	LIST PRICE BY PAINT GRADE	
					P1	P2
	Universal Modesty Panel					
	For 48"W Between™ Tables	HMTUMOD38	11	2.2	\$220	\$240
	For 60"/72"W Between™ Tables	HMTUMOD50	14	3.1	\$242	\$262

NOTES:

- Table Modesty Panels are hinged for use with Nesting Table models.

HOW TO SPECIFY

<p>Select Model Number</p> <p>HMTUMOD38</p>	<p>Select Paint Color</p> <p>See page 752 \$20 upcharge per model, for P2 paint</p> <p>T1</p>
--	--



Icon Legend on page 19

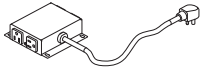

DESCRIPTION

Under Worksurface Power Module

NOTES: For additional information see page 849.

MODEL

HPWRMOD2

SHIP WEIGHT

1.5

CUBE

0.2

LIST PRICE

\$401

HOW TO SPECIFY

Select
Model Number

HPWRMOD2

BUILD™



Build™ Tables shown with SmartLink® Seating.

TABLES

The Build™ series has added new products in 2020 that are not featured in this pricer. Specifying model logic has also changed. Please refer to the new pricer for the new products and specification.

BUILD™

Today's smartest workspaces have the flexibility needed to adapt to the new and evolving ways people work. Working. Focusing. Sharing. Training. Build tables can keep up with it all. And with 12 lightweight, interchangeable table shapes, Build gives you the foundation for building a more productive workplace.



FEATURES

- 12 unique shapes to mix and match — Rectangle, Half-Round, Wisp, Ribbon, Kite, Tide, Dart, Snap, Round, Square, Trapezoid and Arc.
- Height adjustable tables adapt to your changing work style throughout the day.
- In addition to all standard HON laminates, Build tops are available in bright, bold laminates.
- Dry-Erase finish also available on Build tables.
- Legs adjust from 22"H to 34"H in 1" increments.
- Optional casters allow for easy movement on all surfaces.

BUILD™ ORDERING INFORMATION

LAMINATE

L1 LAMINATES CODES

Woodgrain

- ◆ Bourbon Cherry H
- ◆ Cognac COGN
- ◆ Florence Walnut LFW1
- ◆ Harvest C
- ◆ Kingswood Walnut LK11
- ◆ Loft LOFT
- ◆ Mahogany N
- ◆ Mocha MOCH
- ◆ Natural Maple D
- ◆ Pinnacle PINC
- ◆ Shaker Cherry F
- ◆ Sterling Ash LSA1

Solid

- ◆ Black P
- ◆ Charcoal S
- ◆ Designer White LDW1
- ◆ Loft LOFT

Patterned

- ◆ Sheer Mesh A5
- ◆ Silver Mesh B9
- ◆ Steel Mesh A9
- ◆ Canyon Zephyr K9
- ◆ Desert Zephyr K8
- ◆ Shadow Zephyr K1
- ◆ Battleship LBT1
- ◆ Blue Agave * LBA1
- ◆ Gray G2
- ◆ Grey Tigris L6
- ◆ Kiwi * LKW1
- ◆ Moroccan LMN1
- ◆ Mushroom LMH1
- ◆ Neon Carrot LNC1
- ◆ Pomegranate * LBG1
- ◆ Tangerine * LTG1
- ◆ Tennis Ball LTB1
- ◆ White G1
- ◆ Whitestone K4

L2 LAMINATES CODES

Woodgrain

- ◆ Lowell Ash LLA1
- ◆ Natural Recon LNR1
- ◆ Phantom Ecru LPE1
- ◆ Portico Teak LPT1
- ◆ Skyline Walnut LSW1

L5 LAMINATES CODES

- ◆ White FMQ1

PAINT

PAINT CODES

P1

- ◆ Black P

P2

- ◆ Platinum Metallic T1

T-MOLD

T-MOLD CODES

Woodgrain

- ◆ Cognac COGN
- ◆ Florence Walnut FW
- ◆ Kingswood Walnut KI
- ◆ Lowell Ash DL
- ◆ Mahogany N
- ◆ Mocha MOCH
- ◆ Natural Maple D
- ◆ Natural Recon NR
- ◆ Phantom Ecru PE
- ◆ Pinnacle PINC
- ◆ Portico Teak DP
- ◆ Shaker Cherry F
- ◆ Skyline Walnut SW
- ◆ Sterling Ash SA

Solid

- ◆ Atom AT
- ◆ Black P
- ◆ Bullseye BY
- ◆ Charcoal S
- ◆ Designer White DW
- ◆ Ember MR
- ◆ Greige R
- ◆ Ion IO
- ◆ Iris IR
- ◆ Krypton KT
- ◆ Loft LOFT
- ◆ Muslin T
- ◆ Platinum K
- ◆ Regatta RE

◆◆◆ For lead time information see page 19.

* De-emphasized



Icon Legend on page 19

BUILD™ Configurations

QTY	DESCRIPTION	MODEL	LIST PRICE	PRICE EXTENSION
1	Tide Table with 4-Pack Adjustable Post Legs 54"W x 54"D	HETD-54E-4L	\$775	\$775
4	Snap Table with 4-Pack Adjustable Post Legs 54"W x 54"D	HESNP-54E-4L	\$668	\$2,672
TOTAL:				\$3,447

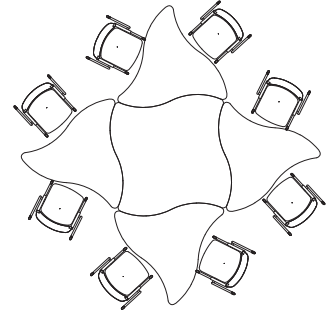

QTY	DESCRIPTION	MODEL	LIST PRICE	PRICE EXTENSION
1	Tide Table with 4-Pack Adjustable Post Legs 54"W x 54"D	HETD-54E-4L	\$775	\$775
8	Dart Table with 4-Pack Adjustable Post Legs 66"W x 27"D	HEDRT-2766E-4L	\$609	\$4,872
TOTAL:				\$5,647

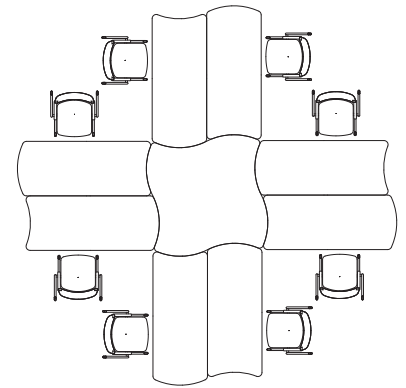

TABLES

QTY	DESCRIPTION	MODEL	LIST PRICE	PRICE EXTENSION
2	Snap Table with 4-Pack Adjustable Post Legs 54"W x 54"D	HESNP-54E-4L	\$668	\$1,336
1	Ribbon Table with 4-Pack Adjustable Post Legs 54"W x 30"D	HESW-3054E-4L	\$603	\$603
TOTAL:				\$1,939

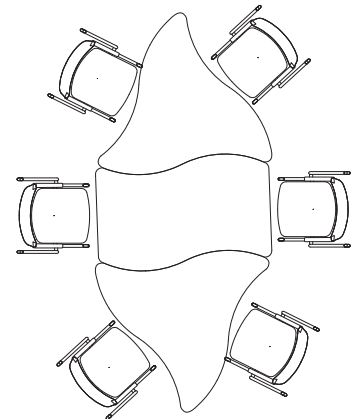

BUILD™ Configurations



Icon Legend on page 19

QTY	DESCRIPTION	MODEL	LIST PRICE	PRICE EXTENSION
1	Snap Table with 4-Pack Adjustable Post Legs 54"W x 54"D	HESNP-54E-4L	\$668	\$668
3	Motivate® Nesting/Stacking Chair; Plastic Shell w/Arms	HMN1	\$508	\$1,524
TOTAL:			\$2,192	

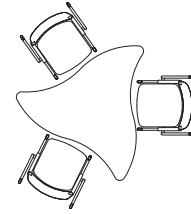

3 PEOPLE / 1 TABLE

QTY	DESCRIPTION	MODEL	LIST PRICE	PRICE EXTENSION
2	Snap Table with 4-Pack Adjustable Post Legs 54"W x 54"D	HESNP-54E-4L	\$668	\$1,336
4	Motivate® Nesting/Stacking Chair; Plastic Shell w/Arms	HMN1	\$508	\$2,032
TOTAL:			\$3,368	

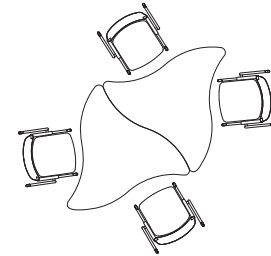

4 PEOPLE / 2 TABLES

QTY	DESCRIPTION	MODEL	LIST PRICE	PRICE EXTENSION
3	Snap Table with 4-Pack Adjustable Post Legs 54"W x 54"D	HESNP-54E-4L	\$668	\$2,004
5	Motivate® Nesting/Stacking Chair; Plastic Shell w/Arms	HMN1	\$508	\$2,540
TOTAL:			\$4,544	

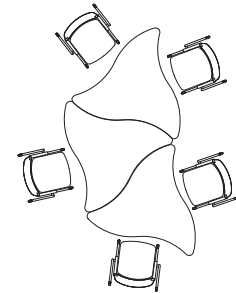

5 PEOPLE / 3 TABLES

QTY	DESCRIPTION	MODEL	LIST PRICE	PRICE EXTENSION
4	Snap Table with 4-Pack Adjustable Post Legs 54"W x 54"D	HESNP-54E-4L	\$668	\$2,672
6	Motivate® Nesting/Stacking Chair; Plastic Shell w/Arms	HMN1	\$508	\$3,048
TOTAL:			\$5,720	

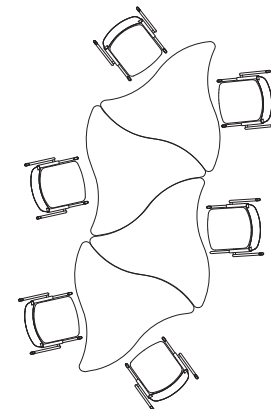

6 PEOPLE / 4 TABLES



Icon Legend on page 19

BUILD™ Configurations

QTY	DESCRIPTION	MODEL	LIST PRICE	PRICE EXTENSION
4	Tide Table with 4-Pack Adjustable Post Legs 54"W x 54"D	HETD-54E-4L	\$775	\$3,100
8	Motivate® Nesting/Stacking Chair; Plastic Shell w/Arms	HMN1	\$508	\$4,064
TOTAL:				\$7,164

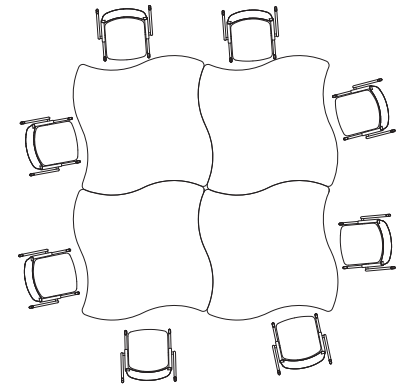

8 PEOPLE / 4 TABLES

QTY	DESCRIPTION	MODEL	LIST PRICE	PRICE EXTENSION
2	Tide Table with 4-Pack Adjustable Post Legs 54"W x 54"D	HETD-54E-4L	\$775	\$1,550
6	Motivate® Nesting/Stacking Chair; Plastic Shell w/Arms	HMN1	\$508	\$3,048
TOTAL:				\$4,598

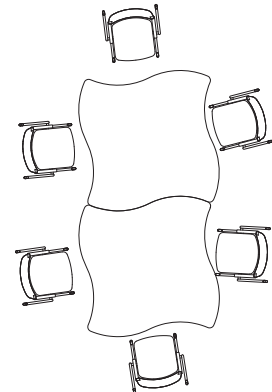

6 PEOPLE / 2 TABLES

QTY	DESCRIPTION	MODEL	LIST PRICE	PRICE EXTENSION
1	Tide Table with 4-Pack Adjustable Post Legs 54"W x 54"D	HETD-54E-4L	\$775	\$775
4	Motivate® Nesting/Stacking Chair; Plastic Shell w/Arms	HMN1	\$508	\$2,032
TOTAL:				\$2,807

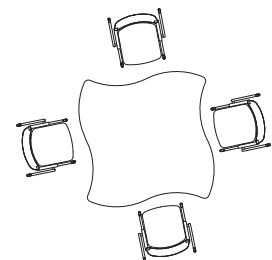

4 PEOPLE / 1 TABLE

TABLES

BUILD™ Configurations



Icon Legend on page 19

QTY	DESCRIPTION	MODEL	LIST PRICE	PRICE EXTENSION
2	Wisp Table with 4-Pack Adjustable Post Legs 54"W x 30"D	HESN-3054E-4L	\$653	\$1,306
2	Dart Table with 4-Pack Adjustable Post Legs 66"W x 27"D	HEDRT-2766E-4L	\$609	\$1,218
8	Motivate® Nesting/Stacking Chair; Plastic Shell w/Arms	HMN1	\$508	\$4,064
TOTAL:			\$6,588	

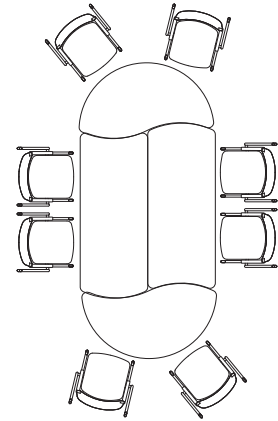

8 PEOPLE / 4 TABLES

QTY	DESCRIPTION	MODEL	LIST PRICE	PRICE EXTENSION
5	Dart Table with 4-Pack Adjustable Post Legs 66"W x 27"D	HEDRT-2766E-4L	\$609	\$3,045
10	Motivate® Nesting/Stacking Chair; Plastic Shell w/Arms	HMN1	\$508	\$5,080
TOTAL:			\$8,125	

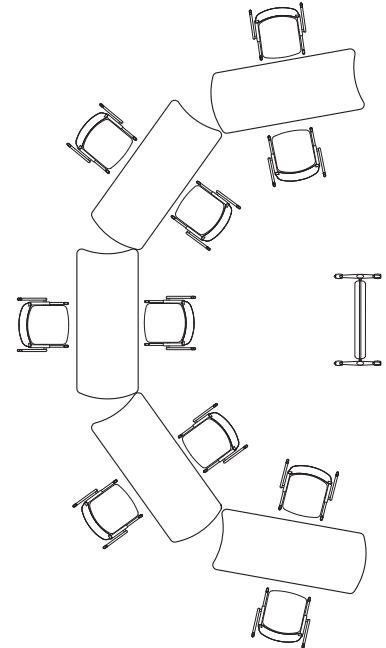

10 PEOPLE / 5 TABLES

TABLES



Icon Legend on page 19

BUILD™ Configurations

QTY	DESCRIPTION	MODEL	LIST PRICE	PRICE EXTENSION
1	Kite Table with 4-Pack Adjustable Post Legs 50"W x 30"D	HESA-3050E-4L	\$668	\$668
1	Motivate® Four-Leg Stack Chair; Plastic Shell w/Arms (Set of 2)	HMG1	\$608	\$608
TOTAL:			\$1,276	

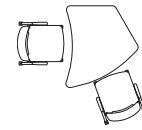

2 PEOPLE / 1 TABLE

QTY	DESCRIPTION	MODEL	LIST PRICE	PRICE EXTENSION
3	Kite Table with 4-Pack Adjustable Post Legs 50"W x 30"D	HESA-3050E-4L	\$668	\$2,004
6	Motivate® Nesting/Stacking Chair; Plastic Shell w/Arms	HMN1	\$508	\$3,048
TOTAL:			\$5,052	

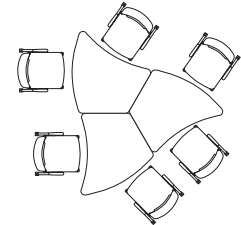

6 PEOPLE / 3 TABLES

QTY	DESCRIPTION	MODEL	LIST PRICE	PRICE EXTENSION
3	Kite Table with 4-Pack Adjustable Post Legs 50"W x 30"D	HESA-3050E-4L	\$668	\$2,004
8	Motivate® Nesting/Stacking Chair; Plastic Shell w/Arms	HMN1	\$508	\$4,064
TOTAL:			\$6,068	

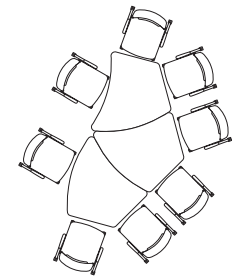

8 PEOPLE / 3 TABLES

QTY	DESCRIPTION	MODEL	LIST PRICE	PRICE EXTENSION
2	Kite Table with 4-Pack Adjustable Post Legs 50"W x 30"D	HESA-3050E-4L	\$668	\$1,336
4	Motivate® Nesting/Stacking Chair; Plastic Shell w/Upholstered Seat/Arms	HMN2	\$572	\$2,288
TOTAL:			\$3,624	

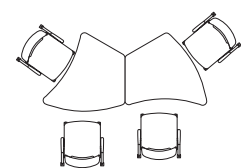

4 PEOPLE / 2 TABLES

QTY	DESCRIPTION	MODEL	LIST PRICE	PRICE EXTENSION
6	Kite Table with 4-Pack Adjustable Post Legs 50"W x 30"D	HESA-3050E-4L	\$668	\$4,008
8	Motivate® Nesting/Stacking Chair; Plastic Shell w/Upholstered Seat/Arms	HMN2	\$572	\$4,576
TOTAL:			\$8,584	

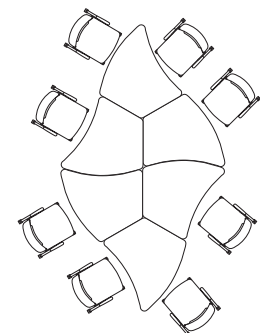

8 PEOPLE / 6 TABLES

TABLES

BUILD™ Configurations



Icon Legend on page 19

QTY	DESCRIPTION	MODEL	LIST PRICE	PRICE EXTENSION
6	Kite Table with 4-Pack Adjustable Post Legs 50"W x 30"D	HESA-3050E-4L	\$668	\$4,008
6	Motivate® Four-Leg Stack Chair; Plastic Shell/Armless (Set of 2)	HMG1	\$548	\$3,288
TOTAL:			\$7,296	

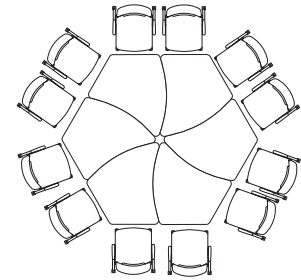

12 PEOPLE / 6 TABLES

QTY	DESCRIPTION	MODEL	LIST PRICE	PRICE EXTENSION
1	Wisp Table with 4-Pack Adjustable Post Legs 54"W x 30"D	HESN-3054E-4L	\$653	\$653
4	Motivate® Nesting/Stacking Chair; Plastic Shell w/Arms	HMN1	\$508	\$2,032
TOTAL:			\$2,685	

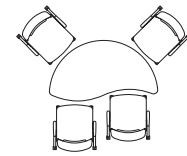

4 PEOPLE / 1 TABLE

QTY	DESCRIPTION	MODEL	LIST PRICE	PRICE EXTENSION
2	Wisp Table with 4-Pack Adjustable Post Legs 54"W x 30"D	HESN-3054E-4L	\$653	\$1,306
4	Motivate® Nesting/Stacking Chair; Plastic Shell w/Upholstered Seat & Back w/Arms	HMN2	\$642	\$2,568
TOTAL:			\$3,874	

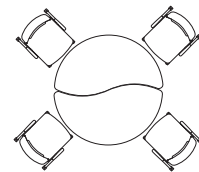

4 PEOPLE / 2 TABLES

QTY	DESCRIPTION	MODEL	LIST PRICE	PRICE EXTENSION
3	Wisp Table with 4-Pack Adjustable Post Legs 54"W x 30"D	HESN-3054E-4L	\$653	\$1,959
6	Motivate® Nesting/Stacking Chair; Plastic Shell w/Upholstered Seat/Arms	HMN2	\$572	\$3,432
TOTAL:			\$5,391	

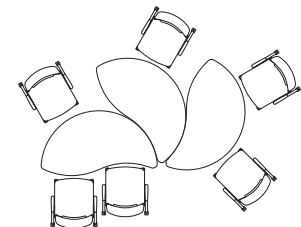

6 PEOPLE / 3 TABLES

QTY	DESCRIPTION	MODEL	LIST PRICE	PRICE EXTENSION
4	Wisp Table with 4-Pack Adjustable Post Legs 54"W x 30"D	HESN-3054E-4L	\$653	\$2,612
7	Motivate® Nesting/Stacking Chair; Plastic Shell w/Arms	HMN1	\$508	\$3,556
TOTAL:			\$6,168	

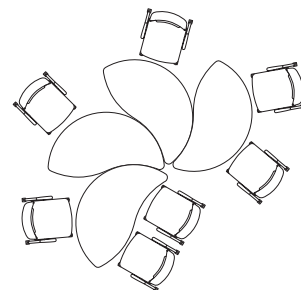

7 PEOPLE / 4 TABLES

TABLES



Icon Legend on page 19

BUILD™ Configurations

QTY	DESCRIPTION	MODEL	LIST PRICE	PRICE EXTENSION
6	Wisp Table with 4-Pack Adjustable Post Legs 54"W x 30"D	HESN-3054E-4L	\$653	\$3,918
6	Motivate® Nesting/Stacking Chair; Plastic Shell w/Arms	HMN1	\$508	\$3,048
TOTAL:			\$6,966	

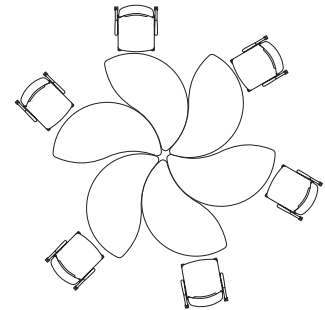

6 PEOPLE / 6 TABLES

QTY	DESCRIPTION	MODEL	LIST PRICE	PRICE EXTENSION
1	Ribbon Table with 4-Pack Adjustable Post Legs 54"W x 30"D	HESW-3054E-4L	\$603	\$603
6	Motivate® Nesting/Stacking Chair; Plastic Shell w/Upholstered Seat & Back w/Arms	HMN2	\$642	\$3,852
TOTAL:			\$4,455	

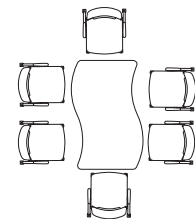

6 PEOPLE / 1 TABLE

QTY	DESCRIPTION	MODEL	LIST PRICE	PRICE EXTENSION
2	Ribbon Table with 4-Pack Adjustable Post Legs 54"W x 30"D	HESW-3054E-4L	\$603	\$1,206
8	Motivate® Nesting/Stacking Chair; Plastic Shell w/Arms	HMN1	\$508	\$4,064
TOTAL:			\$5,270	

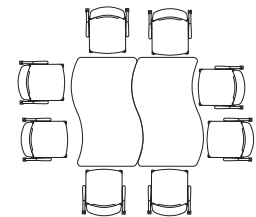

8 PEOPLE / 2 TABLES

QTY	DESCRIPTION	MODEL	LIST PRICE	PRICE EXTENSION
4	Ribbon Table with 4-Pack Adjustable Post Legs 54"W x 30"D	HESW-3054E-4L	\$603	\$2,412
6	Motivate® Four-Leg Stack Chair; Plastic Shell/Armless (Set of 2)	HMG1	\$548	\$3,288
TOTAL:			\$5,700	

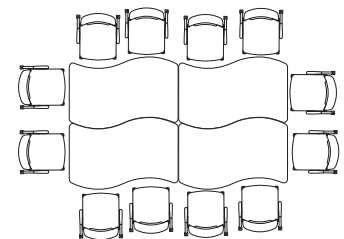

12 PEOPLE / 4 TABLES

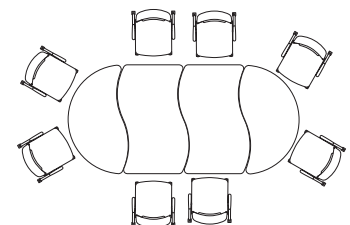

QTY	DESCRIPTION	MODEL	LIST PRICE	PRICE EXTENSION
2	Ribbon Table with 4-Pack Adjustable Post Legs 54"W x 30"D	HESW-3054E-4L	\$603	\$1,206
2	Wisp Table with 4-Pack Adjustable Post Legs 54"W x 30"D	HESN-3054E-4L	\$653	\$1,306
8	Motivate® Nesting/Stacking Chair; Plastic Shell w/Upholstered Seat/Arms	HMN2	\$572	\$4,576
TOTAL:			\$7,088	



8 PEOPLE / 4 TABLES

TABLES

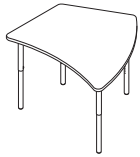

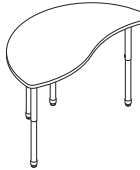
	DESCRIPTION	MODEL	SHIP WEIGHT	CUBE	LIST PRICE BY LAMINATE GRADE		
					L1	L2	L5
	Kite Table with 4 Adjustable Post Legs 40"W x 24"D 50"W x 30"D ⓘ Can be used with other Kite Tables of same size only.	HESA-2440E-4L	49	5.2	\$649	\$664	\$709
		HESA-3050E-4L	69	7.1	\$668	\$688	\$748
	Ribbon Table with 4 Adjustable Post Legs 54"W x 30"D NOTES: Ribbon, Wisp, Snap, Tide and Dart can all be used together.	HESW-3054E-4L	84	5.9	\$603	\$623	\$683
	Wisp Table with 4 Adjustable Post Legs 54"W x 30"D NOTES: Ribbon, Wisp, Snap, Tide and Dart can all be used together.	HESN-3054E-4L	82	5.9	\$653	\$673	\$733

NOTES:

- Legs adjust from 22-34" in 1" increments with a simple set screw.
- Specify paint for upper portion of leg, bottom is chrome.
- Quick set bracket factory installed for easy leg location and installation.
- Optional casters allow for tables to be easily reconfigured.
- Top and base are specified together, but shipped separately.

HOW TO SPECIFY

Select Model Number H E S A - 2 4 4 0 E - 4 L .	Select Grommet N .	Select Laminate Color See page 698 H .	Select T-Mold Color See page 698 P .	Select Paint Color See page 698 P .
---	------------------------------	---	---	--

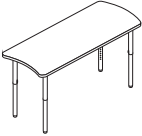
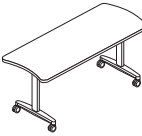

Icon Legend on page 19

	DESCRIPTION	MODEL	SHIP WEIGHT	CUBE	LIST PRICE BY LAMINATE GRADE		
					L1	L2	L5
	Tide Table with 4 Adjustable Post Legs 54"W x 54"D NOTES: Ribbon, Wisp, Snap, Tide and Dart can all be used together.	HETD-54E-4L	125	10.2	\$775	\$803	\$912
	Dart Table with 4 Adjustable Post Legs 66"W x 27"D NOTES: Ribbon, Wisp, Snap, Tide and Dart can all be used together.	HEDRT-2766E-4L	105	7.2	\$609	\$629	\$707
	Dart Table with Nesting Base 66"W x 27"D NOTES: Ribbon, Wisp, Snap, Tide and Dart can all be used together. ! HEDRT-2766E-NS has a height difference of 1/2" when used with Build™ Post Leg models.	HEDRT-2766E-NS	113	8.7	\$1027	\$1047	\$1125

NOTES:

- Legs adjust from 22-34" in 1" increments with a simple set screw.
- Specify paint for upper portion of leg, bottom is chrome.
- Quick set bracket factory installed for easy leg location and installation.
- Optional casters allow for tables to be easily reconfigured.
- Top and base are specified together, but shipped separately.

HOW TO SPECIFY

Select Model Number	Select Grommet N No Grommet	Select Laminate Color See page 698	Select T-Mold Color See page 698	Select Paint Color See page 698
H E T D - 5 4 E - 4 L .	N .	H .	P .	P .

Select Model Number	Select Grommet N No Grommet	Select Laminate Color See page 698	Select T-Mold Color See page 698	Select Caster C Caster ONLY	Select Paint Color See page 698
H E D R T - 2 7 6 6 E - N S .	N .	L B A 1 .	K .	C .	T 1 .



DESCRIPTION

Snap Table with 3 Adjustable Post Legs
54"W x 54"D

MODEL

HESNP-54E-4L

SHIP WEIGHT

65

CUBE

7.7

LIST PRICE BY LAMINATE GRADE

L1

\$668

L2

\$691

L5

\$780

NOTES: Ribbon, Wisp, Snap, Tide and Dart can all be used together. Only 3 legs needed. If ordering multiple Snap Tables, please order table top and legs separately. See models and chart below for ordering information.



Snap Table Top

54"W x 54"D

HESNP54E

46

6.5

\$473

\$496

\$585

NOTES: Top only. Must order with Adjustable Post Legs below (HEB4LEG). See models and chart below for ordering information.

Specify: Model.Grommet.Laminate.T-Mold

SPECIFYING EXAMPLE: HESNP54E.N.H.P.P

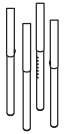

Adjustable Post Legs 4-Pack

22"-34"H

HEB4LEG

19

1.2

\$195

N/A

N/A

NOTES: Legs only. Must order with Snap Table Top above (Model HESNP54E). Only 3 legs needed. See models and chart below for ordering information. Specify upper-leg paint color.

! Must be ordered with a configurable end product. If ordered separately, not on GSA contract.

SPECIFYING EXAMPLE: HEB4LEG.P

NOTES:





- Legs adjust from 22-34" in 1" increments with a simple set screw.
- Specify paint for upper portion of leg, bottom is chrome.
- Quick set bracket factory installed for easy leg location and installation.
- Optional casters allow for tables to be easily reconfigured.
- Top and base are specified together, but shipped separately.

SNAP TABLES	LEGS NEEDED	ADJUSTABLE POST LEGS 4-PACKS
1	3	1
2	6	2
3	9	3
4	12	3
5	15	4
6	18	5
7	21	6
8	24	6
9	27	7
10	30	8

HOW TO SPECIFY

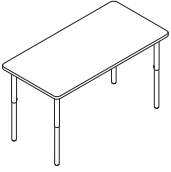
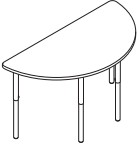
<p>Select Model Number</p> <p>H E S N P - 5 4 E - 4 L .</p>	<p>Select Grommet</p> <p>N No Grommet</p> <p>N .</p>	<p>Select Laminate Color</p> <p>See page 698</p> <p>H .</p>	<p>Select T-Mold Color</p> <p>See page 698</p> <p>P .</p>	<p>Select Paint Color</p> <p>See page 698</p> <p>P .</p>
--	---	--	--	---

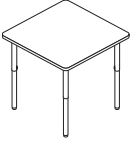

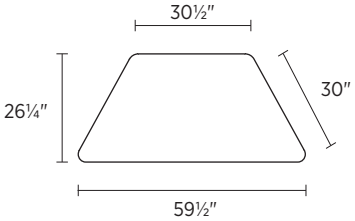
	DESCRIPTION	MODEL	SHIP WEIGHT	CUBE	LIST PRICE BY LAMINATE GRADE		
					L1	L2	L5
	Rectangle Table with 4 Adjustable Post Legs						
	48"W x 24"D	HETR-2448E-4L	64.0	4.9	\$543	\$558	\$603
	60"W x 24"D	HETR-2460E-4L	76.0	5.7	\$579	\$599	\$659
	72"W x 24"D	HETR-2472E-4L	87.0	6.2	\$621	\$641	\$701
	48"W x 30"D	HETR-3048E-4L	80.5	5.7	\$557	\$572	\$617
	60"W x 30"D	HETR-3060E-4L	90.0	6.2	\$591	\$611	\$671
	72"W x 30"D	HETR-3072E-4L	104.0	6.7	\$648	\$668	\$728
	Half-Round Table with 4 Adjustable Post Legs						
	60"W x 30"D	HESH-3060E-4L	88.0	7.3	\$632	\$652	\$712
NOTES: Can be used with other Rectangle and Half-Round Tables (30"D Rectangles, 60"W Rectangles, and 60"W x 30"D Half-Rounds).							
	Arc Table with 4 Adjustable Post Legs						
	72"W x 48"D	HESKD-7248E-4L	130.7	8.5	\$858	\$878	\$938
	Round Table with 4 Adjustable Post Legs						
	42" Diameter	HERD-42E-4L	70.0	6.1	\$504	\$519	\$577
	48" Diameter	HERD-48E-4L	85.0	7.5	\$544	\$561	\$626
	Square Table with 4 Adjustable Post Legs						
	36"W x 36"D	HESQ-36E-4L	65.0	4.9	\$458	\$471	\$520
	42"W x 42"D	HESQ-42E-4L	80.0	6.1	\$533	\$549	\$613
	48"W x 48"D	HESQ-48E-4L	95.0	7.5	\$564	\$582	\$651
	Trapezoid Table with 4 Adjustable Post Legs						
		HETZ-3060E-4L	77.1	4.7	\$523	\$539	\$600
							

NOTES:

- Legs adjust from 22-34" in 1" increments with a simple set screw.
- Specify paint for upper portion of leg, bottom is chrome.
- Bracket welded to leg to allow for easy installation.
- Quick set bracket factory installed for easy leg location and installation.
- Optional casters allow for tables to be easily reconfigured.
- Top and base are specified together, but shipped separately.

HOW TO SPECIFY

Select Model Number	Select Grommet	Select Laminate Color	Select T-Mold Color	Select Paint Color
H E T R - 2 4 4 8 E - 4 L .	N No Grommet	See page 698	See page 698	See page 698
	N .	H .	P .	P .



DESCRIPTION

Locking Casters, 4-Pack

- Black only
- 4 casters per pack
- Caster pack adds 1 1/8" to the overall height.
- All casters lockable
- Threaded attachment bolts
- Can retrofit on Build™ units with glides.

! On 4-leg Build™ tables, can utilize 2 casters and 2 glides for easy repositioning of tables.

MODEL

HHABCASTER

SHIP WEIGHT

1.0

CUBE

0.1

LIST PRICE

\$75



Ganging Hardware

- Includes two ganging links and two screws
- No color designator when specifying. *Example: HMAGANG.*

HMAGANG

1.0 **Ⓢ**

0.1

\$89

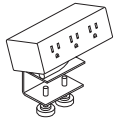

Model HPWRMOD3WC shown

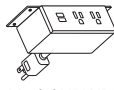

Model HPWRMOD2UWM shown

Power Modules

- 3 Receptacles with Worksurface Clamp
- 3 Receptacles with Under-Worksurface Mounting Bracket
- 2 Receptacles 2 USB with Worksurface Clamp
- 2 Receptacles 2 USB with Under-Worksurface Mounting Bracket

- 6' power cord with standard three-prong plug.
- Under-worksurface mounting bracket models work with any top that has a 5" x 5" square clearance.
- Worksurface clamp models work on any top with a 4" overhang.
- UL Listed.

NOTES: For additional information see page 849.

! Finish choices coordinate with HON's Charcoal or Designer White. *Specify STRM for Storm or SNW for Snow. Example: HPWRMOD3WC.STRM.*

HPWRMOD3WC

2.3 **Ⓢ**

0.2

\$307

HPWRMOD3UWM

2.3 **Ⓢ**

0.2

\$307

HPWRMOD2WC

2.3 **Ⓢ**

0.2

\$491

HPWRMOD2UWM

2.3 **Ⓢ**

0.2

\$491

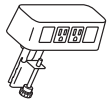

Power & Data Center

- 2 Receptacles 2 Data Accessory
- Standard with two receptacles and openings for two data ports.
- 6' power cord with standard three-prong plug.
- Fits on any worksurface with a 4" overhang.
- UL Listed.

NOTES: For additional information see page 849.

! Color finish coordinates with HON's Loft. *Specify LOFT when ordering. Example: HCOMDOME2.LOFT*

HCOMDOME2

2.5 **Ⓢ**

0.2

\$293



Under Worksurface Power Module — 4 Outlets, 10' Cord

- Includes 10' cord with three-prong plug.
- Fits in cable management troughs. See page 742.
- 4 outlets on side create easy access.

NOTES: Power Modules will also work with standing-height applications for 10500 Series™ and Voi® desks. For additional information see page 849.

! Available in black finish only, no specification needed.

HPWRMOD2

1.5

0.2

\$401

HOW TO SPECIFY

Select Model Number

H H A B C A S T E R

CANTILEVER TABLE



Icon Legend on page 19

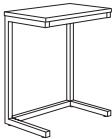

DESCRIPTION

Cantilever Table
17½"W x 9½"D x 20¾"H

MODEL SHIP WEIGHT CUBE LIST PRICE

HML8858 12.8 1.1 \$183

NOTES:

- Welded brackets increase overall strength.
- Single-piece, cross beam construction creates greater durability.
- Scratch-, spill- and stain-resistant laminate stands up to heavy use.
- **HON 5-Year Limited Warranty.**

TABLES

HOW TO SPECIFY

Select Model Number	Select Finish
H M L 8 8 5 8 .	P Black
	P

COORDINATE™



Coordinate™ Base shown with Solve® Task Chairs and Accelerate® Panels.

TABLES

COORDINATE™

Sit-to-stand working is easy when you have table with the power to move with you. The human body wasn't meant to sit for hours on end; and as your body's needs change throughout the day, these height adjustable tables change with you — the height range is different from the 2 stage and 3 stage bases.

Warranty is 5 years.



FEATURES

- The standard memory control, with digital display, quickly and easily adjusts to one of four preset heights.
- Telescoping table base can accommodate work surfaces from 48"–72" wide on the 2-leg model, and from 24"–30" deep.
- Available in 2- and 3-leg base options to accommodate your layout preferences.
- Nickel finish matches any neutral HON paint or finish color.

COORDINATE™ Height Adjustable Bases

OPEN MARKET



Icon Legend on page 19

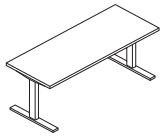

Base shown with work surface attached.

DESCRIPTION

Coordinate™ Height Adjustable Base – 2 Stage
24”D Feet and Worksurface Brackets

MODEL

HHAB2S2L

SHIP WEIGHT

63

CUBE

2.4

LIST PRICE

\$1006

NOTES: Base is a dual motor 2-stage design. Legs raise from 25⁵/₈” to 45³/₄”. Base telescopes to accommodate any rectangular work surface between 24”D x 42”W and 30”D x 72”W. Supports weight capacity of 250 lbs. (excluding work surface weight). See page 718 for Voi® Worksurfaces. See page 718 for Systems Worksurfaces. For Height Adjustable Base Accessories see page 716. Foundation™, Systems, Voi®, 10500, and Preside® all have work surfaces within this range. Comes standard with one-touch, four memory controller with digital display; no specification needed, available in black finish only. **HON 5-Year Limited Warranty.**

⚠ When attaching a Keyboard Tray, remember to also specify a Keyboard Spacer Kit (HKBS).

⚠ Telescoping horizontal frame will extend just over 2” from underside of the work surface.

SPECIFYING EXAMPLE: HHAB2S2L.P8L

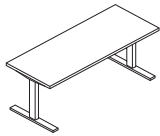

Base shown with work surface attached.

Coordinate™ Height Adjustable Base – 3 Stage
24”D Feet and Worksurface Brackets

HHAB3S2L

67

2.4

\$1120

NOTES: Base is a dual motor 3-stage design. Legs raise from 21⁵/₈” to 47³/₄”. Base telescopes to accommodate any rectangular work surface between 24”D x 42”W and 30”D x 72”W. Supports weight capacity of 250 lbs. (excluding work surface weight). Foundation™, Systems, Voi®, 10500, and Preside® all have work surfaces within this range. Comes standard with one-touch, four memory controller with digital display; no specification needed, available in black finish only. **HON 5-Year Limited Warranty.**

⚠ Telescoping horizontal frame will extend just over 2” from underside of the work surface.

TABLES

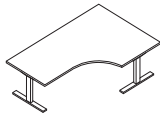

Base shown with work surface attached.

Coordinate™ 3-Leg Height Adjustable Base – 3 Stage
24”D Feet and Worksurface Brackets

HHAB3S3L

91

3.6

\$1896

NOTES: Base is a three motor 3-stage design. Legs raise from 21⁵/₈” to 47³/₄”. **The 3-leg base supports corner covers or two-piece work surfaces 41”-72”W x 35”-72”L x 23³/₄”-30”D. 48”W 120 degree corner work surfaces are also supported. When using two work surfaces, the connection between the two must be over the telescoping frame. Supports weight capacity of 375 lbs. (excluding work surface weight).** Can be used with 48” 120 degree and work surface models. Comes standard with one-touch, four memory controller with digital display; no specification needed, available in black finish only. **HON 5-Year Limited Warranty.**

⚠ When using two work surfaces, a flat bracket is required. Bracket purchased separately — HHN831124, HHN831130 — see page 589.

⚠ Telescoping horizontal frame will extend just over 2” from underside of the work surface.

NOTES:

⚠ Coordinate™ Height Adjustable Bases not compatible with 36”D rectangular work surfaces.

HOW TO SPECIFY

<p>Select Model Number</p> <p>HHAB2S2L.P8L</p>	<p>Select Finish</p> <p>P71 Black P8L Nickel PD8 White</p> <p>P8L</p>
---	--

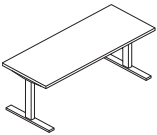
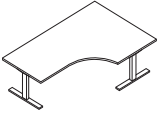

COORDINATE™ Height Adjustable Bases

	DESCRIPTION	MODEL	SHIP WEIGHT	CUBE	LIST PRICE
 <p>Base shown with work surface attached.</p>	<p>Coordinate™ Height Adjustable Base – 3 Stage 24”D Feet and Worksurface Brackets</p> <p>NOTES: Base is a dual motor 3-stage design. Legs raise from 21⁵/₈” to 47³/₄”. Base telescopes to accommodate any rectangular work surface between 24”D x 42”W and 30”D x 72”W. Supports weight capacity of 250 lbs. (excluding work surface weight). Foundation™, Systems, Voi®, 10500, and Preside® all have work surfaces within this range.</p> <p>⚠ Telescoping horizontal frame will extend just over 2” from underside of the work surface.</p>	<p>HHAB3S2L-G *</p>	67	2.4	\$1153
 <p>Base shown with work surface attached.</p>	<p>Coordinate™ 3-Leg Height Adjustable Base – 3 Stage 24”D Feet and Worksurface Brackets</p> <p>NOTES: Base is a three motor 3-stage design. Legs raise from 21⁵/₈” to 47³/₄”. The 3-leg base supports corner covers or two-piece work surfaces 41”-72”W x 35”-72”L x 23¹/₄”-30”D. 48”W 120 degree corner work surfaces are also supported. When using two work surfaces, the connection between the two must be over the telescoping frame. Supports weight capacity of 375 lbs. (excluding work surface weight). Can be used with 48” 120 degree and work surface models.</p> <p>⚠ When using two work surfaces, a flat bracket is required. Bracket purchased separately — HHN831124, HHN831130 — see page 589.</p> <p>⚠ Telescoping horizontal frame will extend just over 2” from underside of the work surface.</p>	<p>HHAB3S3L-G *</p>	91	3.6	\$1951

NOTES:

- ⚠ Coordinate™ Height Adjustable Bases not compatible with 36”D rectangular work surfaces.
- * De-emphasized.

HOW TO SPECIFY

<p>Select Model Number</p>	<p>Select Finish</p> <p>P71 Black P8L Nickel PD8 White</p>
<p>HHAB3S2L-G</p>	<p>P8L</p>

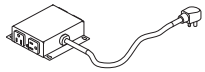

SIN 33721



DESCRIPTION

Under Worksurface Power Module – 4 Outlets, 10' Cord

- Includes 10' cord with three-prong plug.
- Fits in cable management troughs. See page 742.
- 4 outlets on side create easy access.

NOTES: Power Modules will also work with standing-height applications for 10500 Series™ and Voi® desks. For additional information see page 849.

ⓘ Available in black finish only, no specification needed.

MODEL

HPWRMOD2

SHIP WEIGHT

1.5

CUBE

0.2

LIST PRICE

\$401

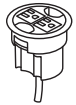

SIN 33721T



3" Round Power Grommet – 2 Outlets, 10' Cord

- Includes 10' cord with three-prong plug.
- Fits in 3" round grommet holes.
- Two grounded AC power outlets.
- Field installed with Plug-and-play ease.

ⓘ Available in black finish only, no specification needed.

HGRMTAC2

1.5

0.2

\$148



SIN 33721T



Power/USB Hub, 3" Grommet Mount

- One grounded AC power outlet with 2 USB ports.
- UL Listed.

NOTES: For additional information see page 848.

ⓘ Available in black only (no color designation so use .X – Specify: HGRMTUSB2.X).

HGRMTUSB2

1.3 ⓘ

0.2

\$224



**Wire Managers for Height Adjustable
Trough to Floor**

HMPHATFWML

2.0

0.3

\$249

OPEN MARKET

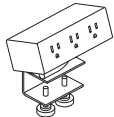

Model HPWRMOD3WC shown

SIN 33721

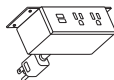

Model HPWRMOD2UWM shown

SIN 33721

Power Modules

- 3 Receptacles with Worksurface Clamp
- 3 Receptacles with Under-Worksurface Mounting Bracket
- 2 Receptacles 2 USB with Worksurface Clamp
- 2 Receptacles 2 USB with Under-Worksurface Mounting Bracket

- 6' power cord with standard three-prong plug.
- Under-worksurface mounting bracket models work with any top that has a 5" x 5" square clearance.
- Worksurface clamp models work on any top with a 4" overhang.
- UL Listed.

NOTES: For additional information see page 849.

ⓘ Finish choices coordinate with HON's Charcoal or Designer White. Specify STRM for Storm or SNW for Snow.
Example: HPWRMOD3WC.STRM.

HPWRMOD3WC

2.3 ⓘ

0.2

\$307

HPWRMOD3UWM

2.3 ⓘ

0.2

\$307

HPWRMOD2WC

2.3 ⓘ

0.2

\$491

HPWRMOD2UWM

2.3 ⓘ

0.2

\$491

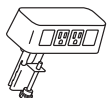

SIN 33721

Power & Data Center

- 2 Receptacles 2 Data Accessory
- Standard with two receptacles and openings for two data ports.
- 6' power cord with standard three-prong plug.
- Fits on any worksurface with a 4" overhang.
- UL Listed.

NOTES: For additional information see page 849.

ⓘ Color finish coordinates with HON's Loft. Specify LOFT when ordering. Example: HCOMDOME2.LOFT.

HCOMDOME2

2.5 ⓘ

0.2

\$293

HOW TO SPECIFY

Select
Model Number

H P W R M O D 2

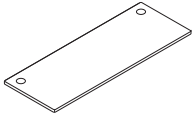

DESCRIPTION	MODEL	SHIP WEIGHT	CUBE	LIST PRICE BY LAMINATE GRADE	
				L1	L2
Systems Rectangle Worksurfaces for Height Adjustable Bases					
46¾"W x 23"D	HHAW2448P	58	3.3	\$429	\$444
52"W x 23"D	HHAW2454P	64	4.0	\$451	\$471
58"W x 23"D	HHAW2460P	70	4.0	\$499	\$519
64"W x 23"D	HHAW2466P	86	4.8	\$535	\$555
70"W x 23"D	HHAW2472P	89	4.8	\$552	\$572

❗ Must be used as worksurfaces on Coordinate™ Height Adjustable Bases within Panel Systems, as these are 1" shorter in width on each side to provide clearance between panels and other worksurfaces.

❗ Available in all standard systems' laminate and edgebanding options. Only offered with grommets.

Specify Model.LaminateColor.EdgeColor.GrommetColor SPECIFYING EXAMPLE: HHAW2448P.A5.K.T1

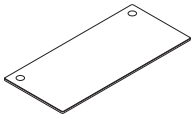

DESCRIPTION	MODEL	SHIP WEIGHT	CUBE	LIST PRICE BY LAMINATE GRADE	
				L1	L2
Systems Rectangle Worksurfaces for Height Adjustable Bases					
46¾"W x 29"D	HHAW3048P	68	4.0	\$458	\$473
52"W x 29"D	HHAW3054P	80	5.0	\$491	\$511
58"W x 29"D	HHAW3060P	101	5.0	\$544	\$564
64"W x 29"D	HHAW3066P	105	6.0	\$578	\$598
70"W x 29"D	HHAW3072P	105	6.0	\$616	\$636

❗ Must be used as worksurfaces on Coordinate™ Height Adjustable Bases within Panel Systems, as these are 1" shorter in width on each side to provide clearance between panels and other worksurfaces.

❗ Available in all standard systems' laminate and edgebanding options. Only offered with grommets.

Specify Model.LaminateColor.EdgeColor.GrommetColor SPECIFYING EXAMPLE: HHAW3048P.A5.K.T1

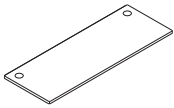

DESCRIPTION	MODEL	SHIP WEIGHT	CUBE	LIST PRICE BY LAMINATE GRADE	
				L1	L2
Voi® Rectangle Worksurfaces for Height Adjustable Bases					
48"W x 24"D	HLSLR2448	61	3.4	\$300	\$315
54"W x 24"D	HLSLR2454	68	4.2	\$323	\$343
60"W x 24"D	HLSLR2460	75	4.2	\$351	\$371
66"W x 24"D	HLSLR2466	82	5.0	\$380	\$400
72"W x 24"D	HLSLR2472	89	5.0	\$394	\$414
48"W x 30"D	HLSLR3048	75	4.2	\$323	\$338
54"W x 30"D	HLSLR3054	84	5.1	\$360	\$380
60"W x 30"D	HLSLR3060	92	5.1	\$402	\$422
66"W x 30"D	HLSLR3066	101	6.1	\$432	\$452
72"W x 30"D	HLSLR3072	110	6.1	\$469	\$489

❗ For use with Coordinate™ Height Adjustable Bases only in Freestanding Applications, which are applications where the tables/desks are not attached or adjacent to another unit, table/desk or systems panel. The widths are true to stated dimensions. If used with Panel Systems or other than in Freestanding Applications, worksurfaces will not provide proper clearance between panels or other worksurfaces, and may cause injury or work surface damage (not covered by warranty).

❗ Coordinate™ Height Adjustable Bases not compatible with 36"D rectangular worksurfaces

❗ See page 188 for specifying information.

NOTES:

- Systems Rectangle Worksurfaces for Height Adjustable Bases designed for use in panel systems. Work surface is 2" shorter in width and 1" shorter in depth to provide clearance between panels and other worksurfaces.

HOW TO SPECIFY

<p>Select Model Number</p> <p>HHAW2448P</p> <p>HLSLR2448</p>	<p>Select Laminate</p> <p>See page 698</p> <p>*For Voi® Worksurfaces only, see page 171</p> <p>A5</p> <p>NN</p>	<p>Select Edge Color</p> <p>See page 698</p> <p>Specify for Systems Worksurfaces only</p> <p>K</p>	<p>Select Grommet Color</p> <p>See page 698</p> <p>Specify for Systems Worksurfaces only</p> <p>T1</p>	<p>Select Grommet Option and Color</p> <p>Specify for Voi® Worksurfaces only</p> <p>X No Grommet</p> <p>G Grommet</p> <p>If choosing the grommet option</p> <p>Select Grommet Color</p> <p>P Black Grommet</p> <p>DW Designer White</p> <p>T5 Greige Grommet</p> <p>T1 Platinum Grommet</p> <p>GT5</p>
---	--	---	---	---

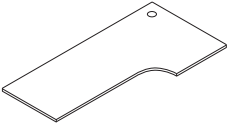
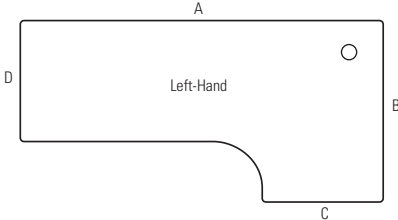
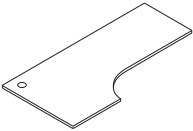
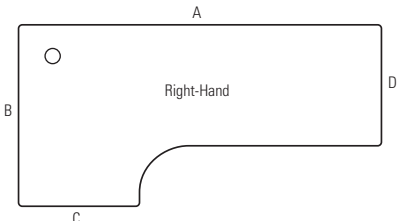

DESCRIPTION	MODEL	SHIP WEIGHT	CUBE	L1 LIST PRICE	L2 LIST PRICE	
 <p>Corner Cove Worksurfaces for Height Adjustable Bases, Left Hand 58" A x 34" B x 23" C x 23" D 70" A x 34" B x 23" C x 23" D</p> <p>58" A x 46" B x 23" C x 23" D 58" A x 46" B x 29" C x 29" D 70" A x 46" B x 23" C x 23" D 70" A x 46" B x 29" C x 29" D</p> 	HHAWV603624LP	67	6.1	\$606	\$631	
	HHAWV723624LP	75	6.8	\$665	\$695	
	HHAWV604824LP	85	7.4	\$665	\$695	
	HHAWV604830LP	99	7.4	\$712	\$742	
	HHAWV724824LP	105	8.8	\$830	\$865	
	HHAWV724830LP	112	8.8	\$880	\$915	
	 <p>Corner Cove Worksurfaces for Height Adjustable Bases, Right Hand 58" A x 34" B x 23" C x 23" D 70" A x 34" B x 23" C x 23" D</p> <p>58" A x 46" B x 23" C x 23" D 58" A x 46" B x 29" C x 29" D 70" A x 46" B x 23" C x 23" D 70" A x 46" B x 29" C x 29" D</p> 	HHAWV603624RP	67	6.1	\$606	\$631
		HHAWV723624RP	75	6.8	\$665	\$695
		HHAWV604824RP	85	7.4	\$665	\$695
		HHAWV604830RP	99	7.4	\$712	\$742
HHAWV724824RP		105	8.8	\$830	\$865	
HHAWV724830RP		112	8.8	\$880	\$915	

TABLES

NOTES:

- Corner Cove Worksurfaces for Height Adjustable Bases designed for use in panel systems. Worksurface is 1" shorter in width and 1" shorter in depth on side of corner to provide clearance between panels and other worksurfaces.
- Use the 3-Leg Coordinate™ Base when specifying Coordinate™ Corner Cove Surfaces.

HOW TO SPECIFY

<p>Select Model Number</p> <p>HHAWV603624LP.</p>	<p>Select Laminate</p> <p>See page 698</p> <p>A5.</p>	<p>Select Edge Color</p> <p>See page 698</p> <p>K.</p>	<p>Select Grommet Color</p> <p>See page 698</p> <p>T1</p>
---	--	---	--



	DESCRIPTION	MODEL	SHIP WEIGHT	CUBE	L1 LIST PRICE	L2 LIST PRICE
	Concinnity™ Rectangle Worksurfaces					
	48"W x 24"D	HNLRC2448	40	3.1	\$274	\$289
	60"W x 24"D	HNLRC2460	50	3.9	\$325	\$345
	66"W x 24"D	HNLRC2466	55	4.2	\$353	\$373
	72"W x 24"D	HNLRC2472	60	4.6	\$366	\$386
	48"W x 30"D	HNLRC3048	50	3.9	\$301	\$316
	60"W x 30"D	HNLRC3060	62	4.7	\$369	\$389
	66"W x 30"D	HNLRC3066	69	5.2	\$395	\$415
	72"W x 30"D	HNLRC3072	75	5.6	\$429	\$449
		10500 Series™ Rectangle Worksurfaces				
48"W x 24"D		H105R2448	44	3.4	\$264	\$279
60"W x 24"D		H105R2460	55	4.2	\$311	\$331
66"W x 24"D		H105R2466	61	4.9	\$331	\$351
72"W x 24"D		H105R2472	66	4.9	\$342	\$362
48"W x 30"D		H105R3048	55	4.1	\$286	\$301
60"W x 30"D		H105R3060	69	5.2	\$349	\$369
66"W x 30"D		H105R3066	76	6.1	\$374	\$394
72"W x 30"D		H105R3072	83	6.1	\$402	\$422

NOTES:

- ❗ For use with Coordinate™ Height Adjustable Bases only in freestanding applications, which are applications where the tables/desks are not attached or adjacent to another unit, table/desk, or systems panel. The widths are true to stated dimensions. If used with Panel Systems or other than in freestanding applications, worksurfaces will not provide proper clearance between panels or other worksurfaces, and may cause injury or worksurface damage (not covered by warranty).
- ❗ Coordinate™ Height Adjustable Bases are not compatible with 36"D rectangular worksurfaces.

HOW TO SPECIFY

<p>Select Model Number</p> <p>H N L R C 2 4 4 8</p> <p>H 1 0 5 R 2 4 4 8</p>	<p>Select Worksurface Laminate and Edge Color</p> <p><i>For Concinnity™ Worksurfaces see page 29</i> <i>For 10500 Series™ Worksurfaces see page 236</i></p> <p>B H</p> <p>N N</p>	<p>Select Worksurface Grommet Finish</p> <p><i>Specify for Concinnity™ Worksurfaces only</i></p> <p>P Black TI Platinum X No Grommet</p> <p>P</p>	<p>Select Worksurface Color</p> <p><i>Specify for Concinnity™ Worksurfaces only. See page 29.</i></p> <p>H</p>
---	--	--	---



Icon Legend on page 19

SYSTEMS WORKSURFACES

120 Degree Corner

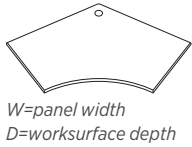

DESCRIPTION	MODEL	SHIP WEIGHT	CUBE	L1 LIST PRICE	L2 LIST PRICE
Abound® and Accelerate® 120 Degree Corner Worksurfaces with Curved User Edge					
42"W x 24"D	HBWCT4224P	96	9.2	\$833	\$848
48"W x 24"D	HBWCT4824P	107	9.2	\$965	\$980
42"W x 30"D	HBWCT4230P	102	11.4	\$1094	\$1109
48"W x 30"D	HBWCT4830P	112	11.4	\$1164	\$1179

- One small worksurface bracket standard with each worksurface.
- ❗ Corner worksurfaces must match exactly the panel behind them, i.e.: a 42" panel must be used on the back two sides of model HBWCT4224P.

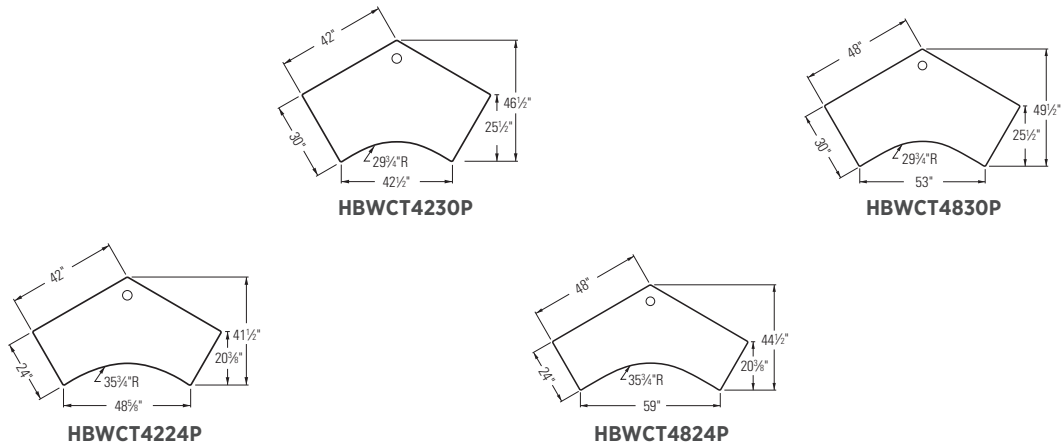

- NOTES:**
- Worksurfaces are constructed of laminate on 1/8" solid core high-performance particleboard.
 - Add suffix **"N"** to Model Number for worksurfaces with no grommets. No upcharge.
 - Cannot use keyboard tray or pedestal under 120 degree corner worksurface.
 - Refer to Worksurface Supports, pages 587-591.
 - If used at an end of run, full end panel needs to be ordered — see page 587.

HOW TO SPECIFY

<p>Select Model Number</p> <p>No Grommet option: Add "N" suffix (no upcharge)</p> <p>HBWCT4224P .</p> <p>HBWCT4224PN .</p>	<p>Select Laminate</p> <p>See page 441</p> <p>AS .</p> <p>AS .</p>	<p>Select Edge Color</p> <p>See page 441</p> <p>K .</p> <p>K .</p>	<p>Select Grommet Color</p> <p>See page 441</p> <p>T1</p>
--	---	---	--

TABLES

COORDINATE™ Shared Components

GSA SIN 33721



Icon Legend on page 19

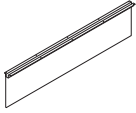

DESCRIPTION	MODEL	SHIP WEIGHT	CUBE	L1	L2
				LIST PRICE	UPCHARGE
Laminate Floating Modesty Panel					
30"W x 14"H	HLSL3014L	10	0.8	\$169	\$10
36"W x 14"H	HLSL3614L	12	0.8	\$179	\$10
42"W x 14"H	HLSL4214L	14	0.8	\$193	\$10
48"W x 14"H	HLSL4814L	16	1.1	\$212	\$12
54"W x 14"H	HLSL5414L	18	1.1	\$232	\$12
60"W x 14"H	HLSL6014L	20	1.1	\$250	\$12

NOTES: The attachment bracket and modesty panel are packaged separately.
Specify: Model.Laminate.Paint

SPECIFYING EXAMPLE: HLSL3014L.N.P (Black is the only paint option for this model)

- ⓘ When specifying the 54"W or 60"W Laminate Floating Modesty Panel, it is not necessary to specify an external channel.
- ⓘ 30"W and 36"W screens attach with L-brackets, not the external channel.

DESCRIPTION	MODEL	SHIP WEIGHT	CUBE	LIST PRICE
Mixed Material Floating Modesty Panel				
30"W x 14"H	HLSL3014MM	8	2.0	\$676
36"W x 14"H	HLSL3614MM	8	2.0	\$726
42"W x 14"H	HLSL4214MM	9	2.3	\$811
48"W x 14"H	HLSL4814MM	11	2.6	\$898
54"W x 14"H	HLSL5414MM	13	3.3	\$974
60"W x 14"H	HLSL6014MM	13	3.3	\$1113

NOTES: The attachment bracket and modesty panel are packaged separately.
Specify: Model.Mixed Material.Paint

SPECIFYING EXAMPLE: HLSL3014MM.FT01.P (Frosted Translucent mixed material and Black paint are the only options for this model)

- ⓘ When specifying the 54"W or 60"W Mixed Material Floating Modesty Panel, it is not necessary to specify an external channel.

FLOATING MODESTY PANELS – MODEL SELECTION GUIDE				
Rectangle Worksurface Width				
72 in	66 in	60 in	48 in	42 in
HLSL6014	HLSL5414	HLSL4814	HLSL3614	HLSL3014

NOTES:

- When using a floating modesty panel under the worksurface, the depth clearance for center drawers and keyboard platforms decreases by 8".

HOW TO SPECIFY

<p>Select Model Number</p> <p>HLSL3014MM</p>	<p>Select Mixed Material</p> <p>FT01 Frosted Translucent</p> <p>FT01</p>
---	--

Desktop Riser & Sit-to-Stand Devices

Icon Legend on page 19

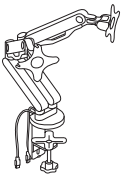
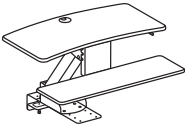
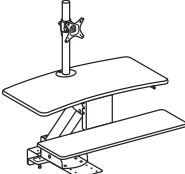
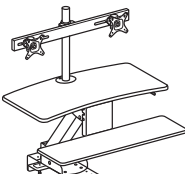
	DESCRIPTION	MODEL	SHIP WEIGHT	CUBE	LIST PRICE
	<p>Portable Desktop Riser 31"D x 5'-16½"H x 35"W</p> <p>NOTES: Available in Black (BLK) or White (WHT) finish. Desktop riser dimensions (without keyboard tray): 22"D x 5'-16½"H x 35"W. Keyboard tray dimensions: 9"D x 30"W. Max loading capacity is 33 lbs for the desktop riser surface and 4 lbs for the keyboard tray. Easily transition from seated to standing positions throughout the workday. Sits atop an existing desk to create sit-to-stand functionality by raising the computer. Includes keyboard tray and surface for computer monitors. HON 5-Year Limited Warranty.</p> <p>⚠ Not intended for use on mobile workstations.</p>	HBXRISER	54.0	4.1	\$619
	<p>Dual Monitor Arm with 2 USB Ports</p> <p>NOTES: Easy adjustment. Height adjusts to 17" tall. Monitor tilt and swivel capability. Enclosed cable management. Grommet or desktop mounting. Clean appearance. In some applications the Monitor Arms may extend 12 or more inches into the worksurface. For additional information see page 825. HON 5-Year Limited Warranty.</p> <p>⚠ No specification needed.</p>	HBDMAUSB	41.9	2.6	\$441
	<p>Mounted Desktop Riser</p> <p>NOTES: Does not include a monitor arm and is suitable for laptops and/or monitors on their original stands.</p> <p>⚠ No specification needed.</p>	HS1100	60.0 Ⓞ	3.2	\$664
	<p>Mounted Desktop Riser with Single Monitor Arm</p> <p>NOTES: Includes a monitor arm for a single monitor.</p> <p>⚠ No specification needed.</p>	HS1101	62.0 Ⓞ	3.2	\$777
	<p>Mounted Desktop Riser with Dual Monitor Arm</p> <p>NOTES: Includes a monitor arm for dual monitors.</p> <p>⚠ No specification needed.</p>	HS1102	63.0 Ⓞ	3.2	\$883

TABLES

NOTES FOR HS1100, HS1101, HS1102:

- These products are designed to allow the user to transition from seating position to standing position throughout the workday.
- Gas-assist lever-operated mechanism with positive stop.
- Clamp mount compatible with worksurfaces depths of 20"-30". 20" is for systems only.
- Clamp requires 3.5" of clearance along back edge of worksurface.
- Black seamless worksurfaces.
- Silver powder coated metal components.
- Lowers below worksurface level on 24" and 30"D worksurfaces.
- All models contain a large primary worksurface and a smaller keyboard / mouse surface.
- Beveled edges for sleek appearance and comfort while typing.
- Monitor arms include height, width, and swivel adjustment.
- For additional information see page 838.

- Not for use under overhead storage, with flush mounted modesty panels, or worksurfaces thinner than 1".
- ⚠ Not recommended for use on mobile (castered) worksurfaces.

MOUNTING AND COMPATIBILITY FOR HS1100, HS1101, HS1102:

- This product is intended to be installed on commercial-grade worksurfaces in good condition.
- Compatible with freestanding worksurfaces 24"-30"D or panel-supported worksurfaces 24"-30"D.
- Not for use on mobile worksurfaces.

Clamp Mount

Use when 3.5" minimum overhang is available

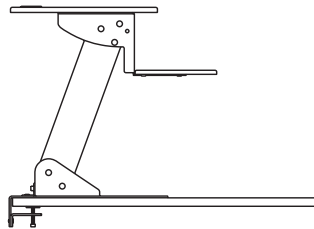

Screw Mount

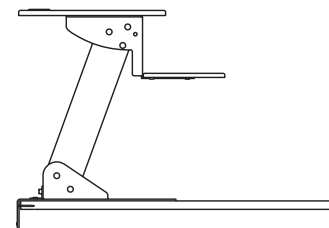

Use when no overhang is available. Worksurface must be minimum 1" thick.



HOW TO SPECIFY

<p>Select Model Number</p> <p>HBXRISER.</p>	<p>Select Finish</p> <p>BLK Black WHT White</p> <p>BLK</p>
--	---

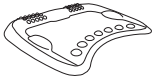
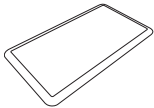
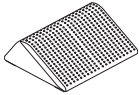

	DESCRIPTION	MODEL	SHIP WEIGHT	CUBE	LIST PRICE
	Rectangle Wobble Board — Anti-Fatigue Mat 18"D x 3"H x 22½"W ⓘ Available in Black (T) finish ONLY. Recommended weight capacity not to exceed 250 pounds. HON 5-Year Limited Warranty. SPECIFYING EXAMPLE: HVL981.T	HVL981	10.0 Ⓢ	0.9	\$120
	Round Wobble Board — Anti-Fatigue Mat 18½"D x 2½"H x 18½"W ⓘ Available in Black (T) finish ONLY. Recommended weight capacity not to exceed 250 pounds. HON 5-Year Limited Warranty. SPECIFYING EXAMPLE: HVL982.T	HVL982	5.8 Ⓢ	0.6	\$102
	Ergonomic Anti-Fatigue Mat 25"D x 2¾"H x 29⅞"W ⓘ Available in Black ONLY. No specification needed. HON 5-Year Limited Warranty. SPECIFYING EXAMPLE: HBEAFM1	HBEAFM1	7.0	1.4	\$219
	Rectangle Anti-Fatigue Mat 20"D x ¾"H x 36"W ⓘ Available in Black ONLY. No specification needed. HON 5-Year Limited Warranty. SPECIFYING EXAMPLE: HBAFM2036	HBAFM2036	5.4	0.4	\$100
	Footrest — Anti-Slip Cover 13¾"D x 5½"H x 16"W ⓘ Available in Black (T) finish ONLY. Recommended weight capacity not to exceed 250 pounds. HON 5-Year Limited Warranty. SPECIFYING EXAMPLE: HVL991.T	HVL991	7.0 Ⓢ	0.9	\$82

HOW TO SPECIFY

Select Model Number <div style="display: flex; gap: 5px;"> <div style="border: 1px solid black; padding: 2px;">H</div> <div style="border: 1px solid black; padding: 2px;">V</div> <div style="border: 1px solid black; padding: 2px;">L</div> <div style="border: 1px solid black; padding: 2px;">9</div> <div style="border: 1px solid black; padding: 2px;">8</div> <div style="border: 1px solid black; padding: 2px;">1</div> </div>	Select Finish T Black
---	---------------------------------

FLOCK®



TABLES

FLOCK®

Great things happen when people come together, and Flock Collaborative Tables create the places that help make that possible. Quiet corners. Vibrant communal areas. Beautiful, comfortable spaces where clean lines and distinctive geometric design improve productivity and inspire big ideas. Choose from a variety of mix-and-match shapes and sizes to design spaces where your Flock will flourish.



FEATURES

- Flock Tables coordinate seamlessly with Flock Seating to support collaborative areas in any workplace.
- Choose from Square, Round, Rectangle or Racetrack shaped table tops.
- Table bases available in multiple heights and styles.
- Add convenient options like integrated power, cord grommets and tablet pedestals, and Flock is ready to work.
- Configurable and scalable, Flock Tables offer smaller footprints to better fit compact spaces.

FLOCK® COLLABORATIVE TABLES ORDERING INFORMATION

TABLES

LAMINATE

TOPS/L1 LAMINATES CODES

Woodgrain

- ◆ Bourbon Cherry **H**
- ◆ Cognac **COGN**
- ◆ Florence Walnut **LFW1**
- ◆ Harvest **C**
- ◆ Kingswood Walnut **LK11**
- ◆ Mahogany **N**
- ◆ Mocha **MOCH**
- ◆ Natural Maple **D**
- ◆ Pinnacle **PINC**
- ◆ Shaker Cherry **F**
- ◆ Sterling Ash **LSA1**

Solid

- ◆ Black **P**
- ◆ Charcoal **S**
- ◆ Designer White **LDW1**
- ◆ Loft **LOFT**

Patterned

- ◆ Sheer Mesh **A5**
- ◆ Silver Mesh **B9**
- ◆ Steel Mesh **A9**
- ◆ Canyon Zephyr **K9**
- ◆ Desert Zephyr **K8**
- ◆ Shadow Zephyr **K1**
- ◆ Whitestone **K4**

TOPS/L2 LAMINATES CODES

Woodgrain

- ◆ Lowell Ash **LLA1**
- ◆ Natural Recon **LNRI**
- ◆ Phantom Ecreu **LPE1**
- ◆ Portico Teak **LPT1**
- ◆ Skyline Walnut **LSW1**

PAINT

PAINT CODES

P1

- ◆ Textured Charcoal **P7A**

P2

- ◆ Textured Silver **PR8**

EDGE BAND

EDGE BAND CODES

- ◆ Black **P**
- ◆ Bourbon Cherry **H**
- ◆ Charcoal **S**
- ◆ Cognac **COGN**
- ◆ Designer White **DW**
- ◆ Florence Walnut **FW**
- ◆ Greige **R**
- ◆ Harvest **C**
- ◆ Kingswood Walnut **KI**
- ◆ Loft **LOFT**
- ◆ Lowell Ash **DL**
- ◆ Mahogany **N**
- ◆ Mocha **MOCH**
- ◆ Muslin **T**
- ◆ Natural Maple **D**
- ◆ Natural Recon **NR**
- ◆ Phantom Ecreu **PE**
- ◆ Pinnacle **PINC**
- ◆ Platinum **K**
- ◆ Portico Teak **DP**
- ◆ Shadow * **SHDW**
- ◆ Shaker Cherry **F**
- ◆ Skyline Walnut **SW**
- ◆ Sterling Ash **SA**

Recommended Edgeband Color Selection:

Laminate		Edgeband	
Bourbon Cherry	H	Bourbon Cherry	H
Cognac	COGN	Cognac	COGN
Florence Walnut	LFW1	Florence Walnut	FW
Harvest	C	Harvest	C
Kingswood Walnut	LK11	Kingswood Walnut	KI
Mahogany	N	Mahogany	N
Mocha	MOCH	Mocha	MOCH
Natural Maple	D	Natural Maple	D
Pinnacle	PINC	Pinnacle	PINC
Shaker Cherry	F	Shaker Cherry	F
Sterling Ash	LSA1	Sterling Ash	SA
Black	P	Black	P
Charcoal	S	Charcoal	S
Designer White	LDW1	Designer White	DW
Whitestone	K4	Muslin	T
Sheer Mesh	A5	Muslin	T
Silver Mesh	B9	Loft	LOFT
Steel Mesh	A9	Charcoal	S
Canyon Zephyr	K9	Greige	R
Desert Zephyr	K8	Greige	R
Shadow Zephyr	K1	Loft	LOFT
Lowell Ash	LLA1	Lowell Ash	DL
Natural Recon	LNRI	Natural Recon	NR
Phantom Ecreu	LPE1	Phantom Ecreu	PE
Portico Teak	LPT1	Portico Teak	DP
Skyline Walnut	LSW1	Skyline Walnut	SW
Loft	LOFT	Loft	LOFT

◆◆◆ For lead time information see page 19.

* De-emphasized

COLLABORATIVE SOLUTIONS TABLE SPECIFYING INFORMATION

TOP SHAPES

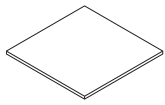

Square



Round

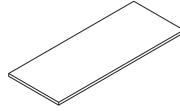

Rectangle



Racetrack

TABLE BASES

For 18"H Tables



T-Leg Style

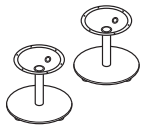

Disc Style

For 29½"H Tables



X-Style



Disc Style

For 41"H Standing-Height Tables

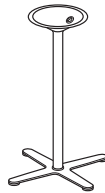

X-Style

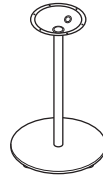

Disc Style

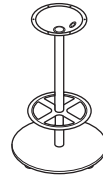

Disc Style with Footring

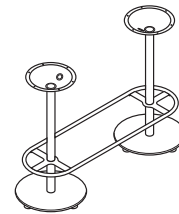

Disc Style with Footring

TABLES



Personal Table



Tablet Accessory

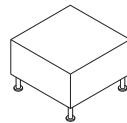

Cube Table



Cylinder Table

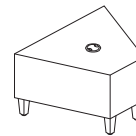

Wedge Table

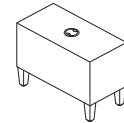

Rectangle Table

GROMMET MATRIX — ALL TABLES/TOPS

TOP WIDTH	NO GROMMET	1-3" ROUND GROMMET CENTERED	2-3" ROUND GROMMET LEFT & RIGHT
SIF OPTION CODE	N	G	G
24" Cube	YES	YES	N/A
26" Cylinder	YES	YES	N/A
18" Personal	N/A	N/A	N/A
30" Square/Round	YES	YES	N/A
36" Square/Round	YES	YES	N/A
60" Rectangle/Racetrack	YES	N/A	YES
72" Rectangle/Racetrack	YES	N/A	YES
84" Rectangle/Racetrack	YES	N/A	YES
96" Rectangle/Racetrack	YES	N/A	YES

NOTES: 3" round grommet color will need to be specified for tops. Grommet will coordinate with paint color specified for cube/cylinder tables. Charcoal grommets will be used with Textured Charcoal paint and Platinum Metallic grommets will be used with Textured Silver paint.

Grommet options can be used in conjunction with accessory ports on cube/cylinder tables. Grommet models HGRMTAC and HGRMTDATA on page 732 can also be used with Flock® tables.

3" ROUND GROMMET LOCATIONS



24", 30", 36" Square



All Rectangle Sizes



26", 30", 36" Round



All Racetrack Sizes

ACCESSORY PORT LOCATIONS

Only applies to models HFTLS24 and HFTLD26.

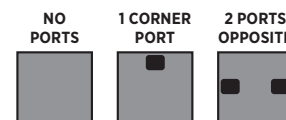

0

1

2

NOTES:

Port location 1 allows for one tablet accessory — see model on pages 730-731.

Port location 2 allows for two tablet accessories — see model on pages 730-731.

FLOCK® Collaborative Laminate Table Tops

GSA SIN 33721



Icon Legend on page 19

	DESCRIPTION	MODEL	SHIP WEIGHT	CUBE	LIST PRICE BY LAMINATE GRADE	
					L1	L2
	Laminate Table Tops					
	36" Square Top	HFTLS36	45	1.2	\$428	\$448
	30" Square Top	HFTLS30	32	1.0	\$380	\$400
	36" Round Top	HFTLD36	35	1.2	\$428	\$448
	30" Round Top	HFTLD30	25	1.0	\$380	\$400
	96"W x 33"D Rectangle Top	HFTLC3396	105	2.9	\$757	\$792
	84"W x 33"D Rectangle Top	HFTLC3384	90	2.5	\$647	\$677
	72"W x 33"D Rectangle Top	HFTLC3372	78	2.2	\$541	\$566
	60"W x 24"D Rectangle Top	HFTLC2460	47	1.3	\$396	\$411
	96"W x 33"D Racetrack Top	HFTLA3396	101	2.9	\$757	\$792
	84"W x 33"D Racetrack Top	HFTLA3384	83	2.5	\$647	\$677
	72"W x 33"D Racetrack Top	HFTLA3372	70	2.2	\$541	\$566
	60"W x 24"D Racetrack Top	HFTLA2460	43	1.3	\$396	\$411

NOTES:

- Grommet models HGRMTAC and HGRMTDATA on page 732 can also be used with Flock® tables.
- Rectangle and Racetrack tops come with 2 grommet cutouts if specified with Round grommet.
- For a complete line of compatible Flock® collaborative seating solutions, please see pages 79-113 of the 2020 Seating Pricer.

TABLES





HOW TO SPECIFY

<p>Select Model Number</p> <p>HFTLS36</p>	<p>Select Edge Detail</p> <p>G 2MM Edge</p> <p>Select Edge Color</p> <p>See page 726</p> <p>GK</p>	<p>Select Grommet Option</p> <p>N No Grommet G Round Grommet (\$15 upcharge per grommet cutout) See page 727 for Grommet placement</p> <p>Select Grommet Color</p> <p>S Charcoal T1 Platinum Metallic</p> <p>GT1</p>	<p>Select Laminate Color</p> <p>See page 726</p> <p>K7</p>
--	---	---	---

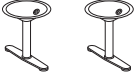
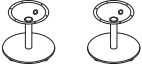

Icon Legend on page 19

FLOCK® Collaborative Table Bases

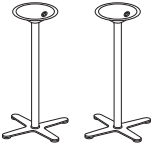
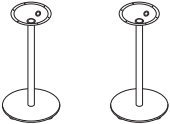
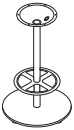
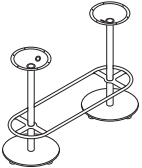
	DESCRIPTION	MODEL	SHIP WEIGHT	CUBE	LIST PRICE BY PAINT GRADE	
					P1	P2
	Base T-Leg Style — For 18”H Tables For 60”W x 24”D Rectangle or Racetrack Table Tops • Two bases shipped in separate cartons.	HFTB17N	40	6.0	\$952	\$972
	Base Disc Style — For 18”H Tables • Use with 60”W x 24”D Racetrack or Rectangle table tops only. • Two bases shipped in separate cartons.	HFDB17N	74	6.0	\$1046	\$1066
	Base Disc Style — For 18”H Tables For 30” and 36” Round or Square Table Tops	HFDB17B	37	3.0	\$512	\$532
	Base X-Style — For 29½”H Tables For 30” Round or Square Table Tops For 36” Round or Square Table Tops Use with 33”D x 72”W x 84”W and 96”W Rectangle or Racetrack Table Tops • Two bases shipped in separate cartons	HFXB29A HFXB29B HFXB29AN	40 53 80	16.1 16.1 32.2	\$596 \$630 \$1192	\$616 \$650 \$1232
	Base X-Style — For 18”H Tables For 30” and 36” Round or Square Table Tops	HFXB17B	37	3.0	\$512	\$532
	Base Disc Style — For 29½”H Tables For 30” Round or Square Table Tops For 36” Round or Square Table Tops Use with 33”D x 72”W x 84”W and 96”W Rectangle or Racetrack Table Tops • Two bases shipped in separate cartons	HFDB29A HFDB29B HFDB29AN	40 56 80	16.1 16.1 32.2	\$596 \$630 \$1192	\$606 \$650 \$1212
	Base X-Style — For 41”H Standing-Height Tables • Use with 33”D x 72”W, 84”W and 96”W Rectangle or Racetrack Table Tops • Two bases shipped in separate cartons	HFXB42AN	84	36.4	\$1250	\$1290
	Base X-Style — For 41”H Standing-Height Tables For 30” Round or Square Table Tops For 36” Round or Square Table Tops	HFXB42A HFXB42B	42 55	18.2 16.1	\$625 \$660	\$645 \$680
	Base Disc Style — For 41”H Standing-Height Tables • Use with 33”D x 72”W, 84”W and 96”W Rectangle or Racetrack table tops, when a Footring is not desired • Two bases shipped in separate cartons	HFDB42AN	92	19.0	\$1212	\$1252
	Base Disc Style — For 41”H Standing-Height Tables For 30” Round or Square Table Tops For 36” Round or Square Table Tops	HFDB42A HFDB42B	46 62	9.5 13.5	\$606 \$643	\$626 \$663
	Base Disc Style with Footring — For 41”H Standing-Height Tables For 30” Round or Square Table Tops For 36” Round or Square Table Tops Use with 33”D x 72”W x 84”W and 96”W Rectangle or Racetrack Table Tops • Two bases shipped in separate cartons	HFDB42AF HFDB42BF HFDB42AFN	56 68 112	9.5 13.5 32.2	\$785 \$823 \$1570	\$805 \$843 \$1610
	Base Disc Style with Footring — For 41”H Standing-Height Tables For 33”D x 96”W Rectangle or Racetrack Table Tops For 33”D x 84”W Rectangle or Racetrack Table Tops For 33”D x 72”W Rectangle or Racetrack Table Tops NOTES: Includes two bases and a single oval footring that spans both tables. Two bases and footring shipped in three separate cartons.	HFDB42AF96 HFDB42AF84 HFDB42AF72	121 123 125	19.7 19.8 19.9	\$1816 \$1756 \$1726	\$1856 \$1796 \$1766

TABLES

NOTES:

- Each base includes adjustable leveling glides.

HOW TO SPECIFY

<p>Select Model Number</p> <p>HFTB17N</p>	<p>Select Paint Color</p> <p>PR8 Textured Silver P7A Textured Charcoal</p> <p>PR8</p>
---	---

FLOCK® Collaborative Tables

GSA SIN 33721



Icon Legend on page 19



DESCRIPTION	MODEL	SHIP WEIGHT	CUBE	L1 LIST PRICE	L2 UPCHARGE
Laminate Personal Table 18" Dia. x 25"H	HFTPTL18	36	4.5	\$618	\$12

HOW TO SPECIFY

Select Model Number H F T P T L 1 8 .	Select Edge Detail/Color See page 726 G H .	Select Laminate Top Color See page 726 H .	Select Base Paint Color PR8 Textured Silver P7A Textured Charcoal P R 8
---	--	---	---

DESCRIPTION	MODEL	SHIP WEIGHT	CUBE	L1 LIST PRICE	L2 UPCHARGE
Laminate Collaborative Cube and Cylinder Tables 24" Laminate Cube Table — 24"W x 24"D x 17½"H	HFTLS24	44	5.0	\$742	\$30
26" Laminate Cylinder Table — 26" Dia. x 17½"H	HFTLD26	39	5.0	\$681	\$30

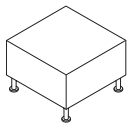

NOTES: Accessory port quantity and configuration on tables should correspond to the accessories planned for the table. For grommet and port information, see page 727.

NOTES:



- Accessory Port options on the Collaborative Cube and Cylinder Tables allow for Tablet Accessory to be added.
- For grommet and port information, see page 727.
- HGRMTAC and HGRMTDATA on page 732 can also be used with Flock® tables.
- Standard Leg (L) can be adjusted for leveling.
- For a complete line of compatible Flock® collaborative seating solutions, please see pages 79-113 of the 2020 Seating Pricer.

HOW TO SPECIFY

Select Model Number H F T L S 2 4 .	Select Grommet Option See page 727 for Grommet placement N No Grommet G Round Grommet — centered (\$15 upcharge)	Select Accessory Port Option See page 727 for Port placement 0 No Port 1 One Corner Port 2 Two Ports — Opposite (\$10 upcharge per port)	Select Laminate Top Color See page 726 H .	Select Leg Option L Standard Leg Leg Options TR Tapered Round Leg TS Tapered Square Leg	Select Paint Color PR8 Textured Silver P7A Textured Charcoal P R 8
---	--	---	---	---	--

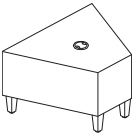
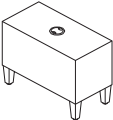

FLOCK® Collaborative Tables

	DESCRIPTION	MODEL	SHIP WEIGHT	CUBE	L1 LIST PRICE	L2 UPCHARGE
 Shown with Round Grommet OPEN MARKET	Laminated Wedge Table 22.17"W x 29.43"D x 17"H	HFTLW45	34	7.7	\$709	\$30
 Shown with Round Grommet OPEN MARKET	Laminated Rectangle Table 24"W x 12"D x 17"H	HFTLR12	29	3.9	\$494	\$20
 SIN 33721	Laminated Tablet Accessory 14" Dia. x 10"H from table top NOTES: Use with Collaborative Cube and Cylinder tables for additional workspace. Attaches to tables through ports. Multiple port location options are available. Tablet pivots/swivels toward the user.	HFTTAL14	6	2.5	\$368	\$15



TABLES

NOTES:

- Accessory Port options on the Collaborative Cube and Cylinder Tables allow for Tablet Accessory to be added.
- For grommet and port information, see page 727.
- HGRMTAC and HGRMTDATA on page 732 can also be used with Flock® tables.
- Standard Leg (L) can be adjusted for leveling.
- For a complete line of compatible Flock® collaborative seating solutions, please see pages 79-113 of the 2020 Seating Pricer.

HOW TO SPECIFY

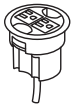
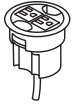
Select Model Number H F T L W 4 5 .	Select Grommet Option See page 727 for Grommet placement N No Grommet G Round Grommet – centered (\$15 upcharge)	Select Accessory Port Option See page 727 for Port placement O No Port	Select Laminate Top Color See page 726 N .	Select Leg Option L Standard Leg Leg Options TR Tapered Round Leg TS Tapered Square Leg	Select Paint Color PR8 Textured Silver P7A Textured Charcoal
Select Model Number H F T T A L 1 4 .	Select Edge Detail/Color See page 726 G H .	Select Laminate Top Color See page 726 H .	Select Paint Color PR8 Textured Silver P7A Textured Charcoal		

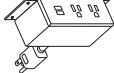
	DESCRIPTION	MODEL	SHIP WEIGHT	CUBE	LIST PRICE
	Power Hub, 3" Grommet Mount, 6' Cord <ul style="list-style-type: none"> Fits in 3" round grommet holes Field installed with Plug-and-play ease Two grounded AC power outlets Includes 6' cord with three-prong plug Available in Black only. <i>Specify X when ordering. Example: HGRMTAC.X.</i> NOTES: For additional information see page 848.	HGRMTAC	1.3	0.2	\$111
	3" Round Power Grommet - 2 Outlets, 10' Cord <ul style="list-style-type: none"> Includes 10' cord with three-prong plug. Fits in 3" round grommet holes. Two grounded AC power outlets. Field installed with Plug-and-play ease. NOTES: Power Modules will also work with standing-height applications for 10500 Series™ and Voi® desks. Optional Memory Control allows preset worksurface heights for consistency. Ships separately. Dynamic load capacity when worksurface is moving is 300 lbs. For additional information see page 848. ⓘ Available in black finish only, no specification needed.	HGRMTAC2	1.5	0.2	\$148
	Power/USB Hub, 3" Grommet Mount <ul style="list-style-type: none"> One grounded AC power outlet with 2 USB ports UL Listed NOTES: For additional information see page 848. ⓘ Available in black only (no color designation so use .X - Specify: HGRMTUSB2.X).	HGRMTUSB2	1.3 ⓘ	0.2	\$224
	Data Grommet <p>Blank grommet kit that includes adapters for a variety of manufacturers jacks and couplers.</p> <ul style="list-style-type: none"> Fits in existing 3" round grommet housing Available in Black only. <i>Specify P when ordering. Example: HGRMTDATA.P.</i> NOTES: For additional information see page 848.	HGRMTDATA	0.2	0.2	\$19
	Power Modules <p>3 Receptacles with Under-Worksurface Mounting Bracket</p> <p>2 Receptacles 2 USB with Under-Worksurface Mounting Bracket</p> <p>6' power cord with standard three-prong plug.</p> <ul style="list-style-type: none"> Under-worksurface mounting bracket models work with any top that has a 5" x 5" square clearance. Worksurface clamp models work on any top with a 4" overhang. UL Listed. NOTES: For additional information see page 849. ⓘ Finish choices coordinate with HON's Charcoal or Designer White. <i>Specify STRM for Storm or SNW for Snow. Example: HPWRMOD3UWM.SNW.</i>	HPWRMOD3UWM HPWRMOD2UWM	2.3 ⓘ 2.3 ⓘ	0.2 0.2	\$307 \$491

Model HPWRMOD2UWM shown

SIN 33721



FOUNDATION™ Conference Tables

	DESCRIPTION	MODEL	SHIP WEIGHT	CUBE	LIST PRICE
	Rectangular Conference Table with Slab Base 72"W x 36"D	HLMC72R	118	9.2	\$367
	Round Conference Table with "X" Base 47" Diameter	HLMC48D	110	6.5	\$302

NOTES:

- Compatible with Foundation™ Caseloads series.
- Tops and bases are packaged together.
- Durable, thermal-fused laminate is scratch- and spill-resistant.
- Easy to Assemble.
- 1 inch thick tops.
- **HON 5-Year Limited Warranty.**

HOW TO SPECIFY

<p>Select Model Number</p> <p>H L M C 7 2 R .</p>	<p>Select Laminate</p> <p>F Shaker Cherry N Mahogany PINC Pinnacle</p> <p>F</p>
--	--

HUDDLE

TABLES



Huddle Tables shown with Motivate® Seating.

HUDDLE

These sturdy, versatile tables link and unlink to quickly transform a space. Temporary workstation? Done. Impromptu conference table? Easy! Training session? No problem. Huddle helps you maximize time and square footage — not costs. And for today's businesses, that's a nice change of pace.



FEATURES

- 1 $\frac{1}{8}$ " thick solid core top is made from durable high-performance particleboard.
- Heavy-grade, warp-resistant particleboard tops and bases withstand heavy activity.
- Mobile nesting base option lets tables fold up and roll away until you need them.
- Choose wiring and power options so Huddle tables are ready to work when you are.
- Modesty panels offer the added level of privacy your employees want.
- Two edge profiles in over 20 colors and patterns to accommodate differing tastes.

HUDDLE ORDERING INFORMATION

LAMINATE

TOPS/L1 LAMINATES CODES

- Woodgrain**
- ◆ Bourbon Cherry H
 - ◆ Cognac COGN
 - ◆ Florence Walnut LFW1
 - ◆ Harvest C
 - ◆ Kingswood Walnut LK11
 - ◆ Mahogany N
 - ◆ Mocha MOCH
 - ◆ Natural Maple D
 - ◆ Pinnacle PINC
 - ◆ Shaker Cherry F
 - ◆ Sterling Ash LSA1
- Solid**
- ◆ Black P
 - ◆ Charcoal S
 - ◆ Designer White LDW1
 - ◆ Loft LOFT
- Patterned**
- ◆ Sheer Mesh A5
 - ◆ Silver Mesh B9
 - ◆ Steel Mesh A9
 - ◇ Canyon Zephyr K9
 - ◇ Desert Zephyr K8
 - ◇ Shadow Zephyr K1
 - ◆ Gray G2
 - ◆ Grey Tigris L6
 - ◇ White G1
 - ◆ Whitestone K4

TOPS/L2 LAMINATES CODES

- Woodgrain**
- ◆ Lowell Ash LLA1
 - ◆ Natural Recon LNR1
 - ◆ Phantom Ecrú LPE1
 - ◆ Portico Teak LPT1
 - ◆ Skyline Walnut LSW1

EDGE BAND

EDGES/ EDGE BAND (2 MM) CODES

- ◆ Black P
- ◆ Bourbon Cherry H
- ◆ Charcoal S
- ◆ Cognac COGN
- ◆ Designer White DW
- ◆ Florence Walnut FW
- ◇ Greige R
- ◆ Harvest C
- ◆ Kingswood Walnut KI
- ◆ Loft LOFT
- ◆ Lowell Ash DL
- ◆ Mahogany N
- ◆ Mocha MOCH
- ◆ Muslin T
- ◆ Natural Maple D
- ◆ Natural Recon NR
- ◆ Phantom Ecrú PE
- ◆ Pinnacle PINC
- ◇ Platinum K
- ◆ Portico Teak DP
- ◇ Shadow* SHDW
- ◆ Shaker Cherry F
- ◆ Skyline Walnut SW
- ◆ Sterling Ash SA

T-MOLD

T-MOLD CODES

- ◆ Black P
- ◆ Charcoal S
- ◆ Designer White DW
- ◇ Greige R
- ◆ Loft LOFT
- ◆ Lowell Ash DL
- ◆ Muslin T
- ◆ Natural Recon NR
- ◆ Phantom Ecrú PE
- ◇ Platinum K
- ◆ Portico Teak DP
- ◇ Shadow* SHDW
- ◆ Skyline Walnut SW

PAINT

BASE PAINT CODES

- P1**
- ◆ Black P
 - ◆ Brownstone P7D
 - ◆ Charcoal S
 - ◆ Designer White PJW
 - ◆ Fossil P28
 - ◆ Greige T5
 - ◆ Light Gray Q
 - ◆ Loft LOFT
 - ◆ Muslin T3
 - ◆ Putty L
 - ◆ Shadow* SHDW
 - ◆ Titanium P8T
- P2**
- ◆ Champagne Metallic T4
 - ◆ Platinum Metallic T1
 - ◆ Silver PR6
- P3**
- ◆ Atom P8S
 - ◆ Bullseye PJF
 - ◆ Ember P8P
 - ◆ Ion P8N
 - ◆ Iris P8J
 - ◆ Krypton P8F
 - ◆ Regatta P8M

Recommended Edgeband Color Selection:

Laminate		Edge	
Bourbon Cherry	H	Bourbon Cherry	H
Cognac	COGN	Cognac	COGN
Florence Walnut	LFW1	Florence Walnut	FW
Harvest	C	Harvest	C
Kingswood Walnut	LK11	Kingswood Walnut	KI
Mahogany	N	Mahogany	N
Mocha	MOCH	Mocha	MOCH
Natural Maple	D	Natural Maple	D
Pinnacle	PINC	Pinnacle	PINC
Shaker Cherry	F	Shaker Cherry	F
Sterling Ash	LSA1	Sterling Ash	SA
Black	P	Black	P
Charcoal	S	Charcoal	S
Designer White	LDW1	Designer White	DW
Loft	LOFT	Loft	LOFT
Whitestone	K4	Muslin	T
Sheer Mesh	A5	Muslin	T
Silver Mesh	B9	Loft	LOFT
Steel Mesh	A9	Charcoal	S
Canyon Zephyr	K9	Greige	R
Desert Zephyr	K8	Greige	R
Shadow Zephyr	K1	Loft	LOFT
Gray	G2	Charcoal	S
Grey Tigris	L6	Greige	R
White	G1	Charcoal	S
Lowell Ash	LLA1	Lowell Ash	DL
Natural Recon	LNR1	Natural Recon	NR
Phantom Ecrú	LPE1	Phantom Ecrú	PE
Portico Teak	LPT1	Portico Teak	DP
Skyline Walnut	LSW1	Skyline Walnut	SW

◆◆◆ For lead time information see page 19.

* De-emphasized

HUDDLE

Multi-Purpose Tables

Huddle Multi-Purpose Tables are ready to jump into action for training, meetings, collaboration and more. Thoughtful design, flexibility and plenty of base, edge and finish options, make Huddle tables capable of meeting the needs of smart, agile businesses.

Tops - Rectangle

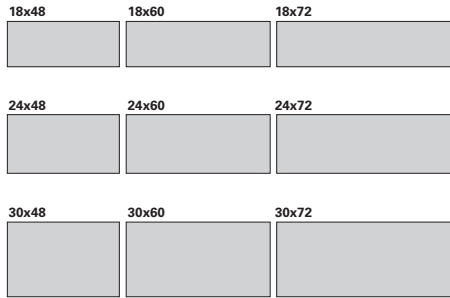

Edge Options



T-Mold



2 mm

TABLES

Tops - Half-Round and Extended Half-Round

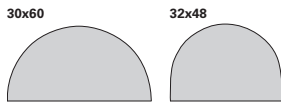

Bases

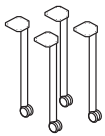

Post Leg w/Casters

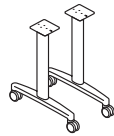

T-Leg w/Casters



Flip-top w/Casters

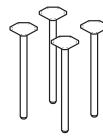

Post Leg w/Glides

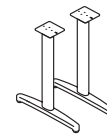

T-Leg w/Glides



3" Power Hub w/USB

Accessories

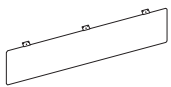

Modesty Panel

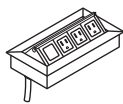

Pop-Up Port

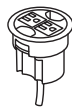

Power Hub, 3" Grommet Mount



Data Grommet



Ganging Hardware

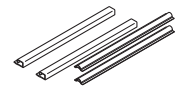

Wire Management Strips

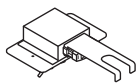

Power Entry Plate

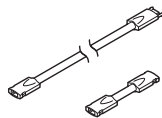

Power In-Feed Cable

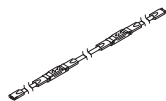

Power Kit

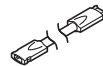

Power Jumper Cable

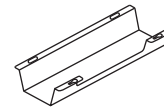

Cable Trough

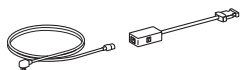

Power Base In-Feed

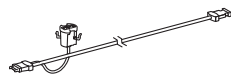

Power Harnesses

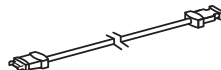

Power Jumper



Icon Legend on page 19

HUDDLE Typicals

QTY	DESCRIPTION	MODEL	LIST PRICE	PRICE EXTENSION
12	Rectangular Table Top 60"W x 24"D	HMT2460G	\$381	\$4,572
12	Flip-top Base	HMBFLIP24L.C	\$613	\$7,356
21	Perpetual® Nesting Chair	HPN1	\$673	\$14,133
TOTAL:				\$26,061

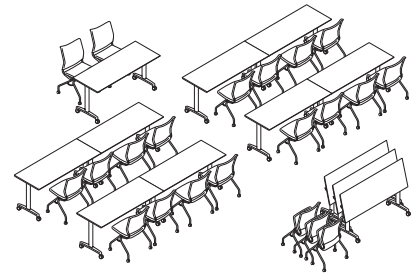

TRAINING

QTY	DESCRIPTION	MODEL	LIST PRICE	PRICE EXTENSION
4	Rectangular Table Top 72"W x 30"D	HMT3072G	\$449	\$1,796
4	Post Leg Base	HMBPOST	\$352	\$1,408
8	Perpetual® Nesting Chair	HPN1	\$673	\$5,384
TOTAL:				\$8,588

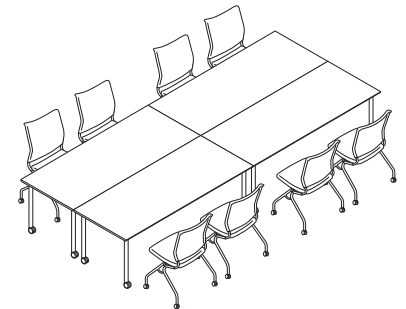

MEETING/CONFERENCE

QTY	DESCRIPTION	MODEL	LIST PRICE	PRICE EXTENSION
2	Rectangular Table Top 72"W x 30"D	HMT3072G	\$449	\$898
2	Half-round Table Top	HMTHR3060G	\$433	\$866
2	Flip-top Base	HMBFLIP30L	\$613	\$1,226
2	Flip-top Base	HMBFLIP24S	\$613	\$1,226
4	Perpetual® Nesting Chair	HPN1	\$673	\$2,692
TOTAL:				\$6,908

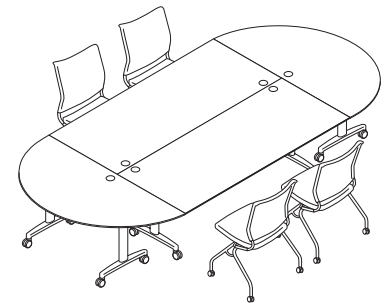

MEETING

TABLES

HUDDLE Typicals



Icon Legend on page 19

QTY	DESCRIPTION	MODEL	LIST PRICE	PRICE EXTENSION
8	Rectangular Table Top 60"W x 30"D	HMT3060G	\$393	\$3,144
8	Fixed Height T-Leg Base with Casters	HMBTLEG24.C	\$418	\$3,344
8	Perpetual® Nesting Chair	HPN1	\$673	\$5,384
TOTAL:				\$11,872

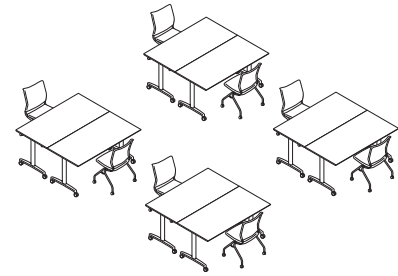

GROUP BREAKOUT

TABLES

QTY	DESCRIPTION	MODEL	LIST PRICE	PRICE EXTENSION
6	Rectangular Table Top 72"W x 24"D	HMT2472G	\$422	\$2,532
6	Fixed Height T-Leg Base with Casters	HMBTLEG24.C	\$418	\$2,508
12	Perpetual® Nesting Chair	HPN1	\$673	\$8,076
TOTAL:				\$13,116

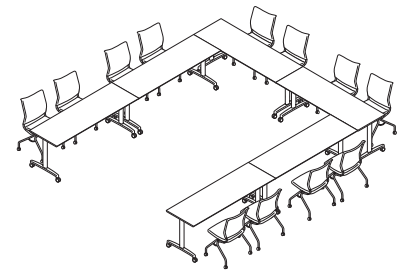

PRESENTATION



Icon Legend on page 19

HUDDLE

Multi-Purpose Table Tops

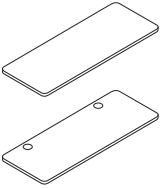
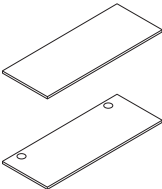
	DESCRIPTION	MODEL	SHIP WEIGHT	CUBE	LIST PRICE BY LAMINATE GRADE		
					L1	L2	
 <p>HMT1848E</p>	Rectangular T-Mold Table Tops						
	48"W x 18"D	HMT1848E	34	2.9	\$305	\$315	
	60"W x 18"D	HMT1860E	42	3.5	\$326	\$341	
	72"W x 18"D	HMT1872E	51	3.9	\$400	\$415	
	48"W x 24"D	HMT2448E	45	3.7	\$344	\$359	
	60"W x 24"D	HMT2460E	57	4.5	\$381	\$401	
	72"W x 24"D	HMT2472E	68	5.0	\$422	\$442	
	48"W x 30"D	HMT3048E	57	4.4	\$359	\$374	
	60"W x 30"D	HMT3060E	71	5.4	\$393	\$413	
	72"W x 30"D	HMT3072E	85	6.0	\$449	\$469	
	 <p>HMT1848G</p>	Rectangular Edgeband Table Tops					
		48"W x 18"D	HMT1848G	34	2.9	\$305	\$315
60"W x 18"D		HMT1860G	42	3.5	\$326	\$341	
72"W x 18"D		HMT1872G	51	3.9	\$400	\$415	
48"W x 24"D		HMT2448G	45	3.7	\$344	\$359	
60"W x 24"D		HMT2460G	57	4.5	\$381	\$401	
72"W x 24"D		HMT2472G	68	5.0	\$422	\$442	
48"W x 30"D		HMT3048G	57	4.4	\$359	\$374	
60"W x 30"D		HMT3060G	71	5.4	\$393	\$413	
72"W x 30"D		HMT3072G	85	6.0	\$449	\$469	

TABLES

NOTES:

- Table tops are 1/8" thick.
- When post legs are used with 18"D tops, post leg to be specified with glides only.
- ! Round grommets available in Black only.
- ! Pop-up Port option (G1) is unfinished. Insert accessory must be ordered separately.

HOW TO SPECIFY

<p>Select Model Number</p> <p>HMT1848G</p>	<p>Select Grommet Option</p> <p>N No Grommet G 2 Grommets (Black only) (\$30 upcharge) G1 Cutout for Pop-up Port (\$40 upcharge). Order port separately.</p> <p>N</p>	<p>Select Laminate</p> <p>See page 735</p> <p>D</p>	<p>Select Edge Color</p> <p>See page 735</p> <p>D</p>
---	--	--	--



HUDDLE

Multi-Purpose Table Tops

GSA SIN 33721

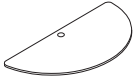

Icon Legend on page 19

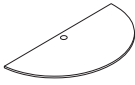
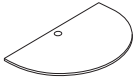
	DESCRIPTION	MODEL	SHIP WEIGHT	CUBE	LIST PRICE BY LAMINATE GRADE	
					L1	L2
 HMTHR3060E	Half-Round and Extended Half-Round T-Mold Table Tops 60"W x 30"D, Half-Round Table Tops (use bases: HMBFLIP24S or HMBTLEG24 or HMBPOST)	HMTHR3060E	69	6.1	\$433	\$453
		HMTHR3248E	57	6.1	\$422	\$442
 HMTHR3248E	48"W x 32"D, Extended Half-Round Table Tops (use bases: HMBFLIP24S or HMBTLEG24)					
<hr/>						
 HMTHR3060G	Half-Round and Extended Half-Round Edgeband Table Tops 60"W x 30"D, Half-Round Table Tops (use bases: HMBFLIP24S or HMBTLEG24 or HMBPOST)	HMTHR3060G	69	6.1	\$433	\$453
		HMTHR3248G	57	6.1	\$422	\$442
 HMTHR3248G	48"W x 32"D, Extended Half-Round Table Tops (use bases: HMBFLIP24S or HMBTLEG24)					

TABLES

NOTES:

- Table tops are 1½" thick.
- ❗ Round grommets available in Black only.
- ❗ Pop-up Port option (G1) is unfinished. Insert accessory must be ordered separately.

HOW TO SPECIFY

<p>Select Model Number</p> <p>H M T H R 3 2 4 8 G .</p>	<p>Select Grommet Option</p> <p>N No Grommet G 1 Grommet (Black only) (\$15 upcharge) G1 Cutout for Pop-up Port (\$40 upcharge). Order port separately.</p> <p>N .</p>	<p>Select Laminate</p> <p>See page 735</p> <p>D .</p>	<p>Select Edge Color</p> <p>See page 735</p> <p>D</p>
--	--	--	--



HUDDLE Multi-Purpose Table Bases

	DESCRIPTION	MODEL	SHIP WEIGHT	CUBE	CORE LIST PRICE
	Fixed Height T-Leg Base (Includes 2 T-legs)				
	For 18"D Table Tops	HMBTLEG18	12	3.6	\$418
	For 24"D and 30"D Table Tops (excluding 84"W and 96"W Rectangular Tops)	HMBTLEG24	14	3.6	\$418
	! When specifying T-legs with 60"W Huddle worksurface HMT1860(?), HMT2460(?), and HMT3060(?) add external channel model HSLZ55SC54.				
	Flip-top Base (Includes 1 Complete Base)				
	For 18"D x 48"W Rectangular Table Tops	HMBFLIP18S	23	4.1	\$613
	For 18"D x 60"W, 72"W Rectangular Table Tops	HMBFLIP18L	26	4.1	\$613
	For 24"D x 48"W and 32"D x 48"W Rectangular Tops and 30"D x 60"W Half-Round Table Tops	HMBFLIP24S	24	4.1	\$613
	For 24"D x 60"W, 72"W Rectangular Table Tops	HMBFLIP24L	27	4.1	\$613
	For 30"D x 48"W Rectangular Table Tops	HMBFLIP30S	24	4.1	\$613
For 30"D x 60"W, 72"W Rectangular Table Tops	HMBFLIP30L	27	4.1	\$613	
	Post Leg Base (Includes 4 Post Legs)				
	For all Tops (excluding 84"W and 96"W Rectangular Tops and 32" x 48" Half-Round Tops)	HMBPOST	18	2.3	\$352
	! When specifying post leg with 60"W Huddle worksurface HMT1860(?), HMT2460(?), and HMT3060(?) add external channel model HSLZ55SC60.				

Table Top to Base Compatibility Chart:

	Flip-Top	T-Leg	Post Leg
18"D x 48"W	HMBFLIP18S	HMBTLEG18	HMBPOST*
18"D x 60"W	HMBFLIP18L	HMBTLEG18	HMBPOST*
18"D x 72"W	HMBFLIP18L	HMBTLEG18	HMBPOST*
24"D x 48"W	HMBFLIP24S	HMBTLEG24	HMBPOST
32"D x 48"W HR	HMBFLIP24S	HMBTLEG24	N/A
30"D x 60"W HR	HMBFLIP24S	HMBTLEG24	HMBPOST
24"D x 60"W	HMBFLIP24L	HMBTLEG24	HMBPOST
24"D x 72"W	HMBFLIP24L	HMBTLEG24	HMBPOST
30"D x 48"W	HMBFLIP30S	HMBTLEG24	HMBPOST
30"D x 60"W	HMBFLIP30L	HMBTLEG24	HMBPOST
30"D x 72"W	HMBFLIP30L	HMBTLEG24	HMBPOST

*Post legs should be specified with glides for use on 18"D worksurfaces.
NOTE: Glides/casters are NOT interchangeable on Post Leg and T-base.

NOTES:

- When glides are specified, adjustable range is 1".
- Flip-top base is standard with casters.
- When post legs are used with 18"D tops, post leg to be specified with glides only.

HOW TO SPECIFY



<p>Select Model Number</p> <p>H M B T L E G 1 8</p>	<p>Select Glide/Caster Option</p> <p>G Glide C Caster</p> <p>Flip-top base is available with casters only</p> <p>When post legs are used with 18"D tops, specify with glides only</p> <p>G</p>	<p>Select Paint Color</p> <p>See page 735</p> <p>\$20 upcharge per model, for P2 paint</p> <p>\$30 upcharge per model, for P3 paint</p> <p>T 1</p>
--	---	--

HUDDLE Table Accessories

GSA SIN 33721

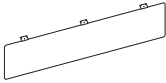

Icon Legend on page 19

	DESCRIPTION	MODEL	SHIP WEIGHT	CUBE	LIST PRICE BY PAINT GRADE		
					P1	P2	P3
	Universal Modesty Panel For 48"W Huddle Tables For 60"W & 72"W Huddle Tables	HMTUMOD32	9	1.9	\$211	\$231	\$241
		HMTUMOD44	12	2.5	\$231	\$251	\$261
	NOTES: Universal Modesty Panels nest between the table legs.						
	Ganging Hardware • Includes two ganging links and two screws • No color designator when specifying. <i>Example: HMAGANG.</i>	HMAGANG	1 	0.1	\$89		

NOTES:

- Ganging Hardware must be ordered and installed on tables when using 4-trac electrical systems.
- Ganging hardware attaches to underside of table in pre-drilled pilot holes.
- Vertical Wire Management Strips must be trimmed when applied to legs of T-Leg and Flip-Top Bases with casters.

TABLES







HOW TO SPECIFY

<p>Select Model Number</p> <p>H M T U M O D 3 2 . S</p>	<p>Select Paint Color</p> <p>See page 752</p> <p>S</p>
---	--

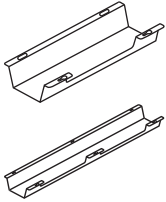
GSA SIN AS NOTED

CABLE MANAGEMENT

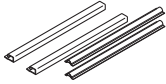
Icon Legend on page 19









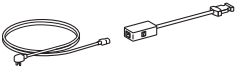

	DESCRIPTION	MODEL	SHIP WEIGHT	CUBE	LIST PRICE
	Cable Management Troughs 17"W — Single 17"W — 10-Pack 36"W — Single 36"W — 10-Pack	HCTROUGH17	3 	0.5	\$67
		HCTROUGH1710	14 	0.5	\$620
		HCTROUGH36	5 	0.9	\$113
		HCTROUGH3610	30 	0.9	\$1045
		• Metal Cable Management Troughs ship flat • Troughs attach to underside of worksurface with screws • Cutouts in trough allow access to power without the need to detach from surface. 17"W = 1 cutout; 36"W = 2 cutouts. • Graphite only, no need to specify • TAA Compliant • Slim profile design			
	NOTES: For additional information see page 852.				
	Wire Management Strips Includes: 2 - 24" vertical strips 2 - 24" horizontal strips • Available in Black only. <i>Specify P when ordering. Example: HBTMS.P.</i> • HON 5-Year Limited Warranty.	HBTMS	3 	0.2	\$103
OPEN MARKET					

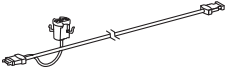
HOW TO SPECIFY

<p>Select Model Number</p> <p>H C T R O U G H 1 7</p>

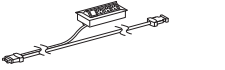

INTERLINK IQ ELECTRICAL

	DESCRIPTION	MODEL	SHIP WEIGHT	CUBE	LIST PRICE
	Power Base In-Feed	HQB	2.0 	0.2	\$520
	Power Harness – 1' Power Hub, 3" Round Grommet Mount	HQH1-3	2.0 	0.2	\$169
	Power Harness – 5' Power Hub, 3" Round Grommet Mount	HQH5-3	2.0 	0.2	\$190
	Power Harness – 5' with 4" x 8" Pop-Up Port	HQH5-P	3.0 	0.3	\$370
	Power Jumper – 3'	HQJ3	2.0 	0.2	\$105

Specification guide for IQ Electrical on Huddle tables

Determine table width, the type of power access being used (3" grommet or 4x8 pop-up) and the desired number per table (Columns 1, 2 or 3). The table will then identify the type and quantity of components needed per table along with the maximum table run. Note that this is in addition to the Power base in-feed which is needed for each run. For example, a 48"W table with two 3" power grommets per table will require (1) HQH5-3 harness and (1) HQH1-3 harness per table with a maximum run of four tables.

Top Width	POWER ONE (1) PER TABLE 3" ROUND POWER GROMMET		POWER TWO (2) PER TABLE 3" ROUND POWER GROMMETS		POWER ONE (1) PER TABLE 4x8 POP-UP PORT	
	Quantity	Table Run Maximum	Quantity	Table Run Maximum	Quantity	Table Run Maximum
36"	(1) HQH5-3	8	N/A	N/A	(1) HQH5-P	8
42"	(1) HQH5-3	8	N/A	N/A	(1) HQH5-P	8
48"	(1) HQH5-3	8	(1) HQH5-3 (1) HQH1-3	4 Max Table Run	(1) HQH5-P	8 Max Table Run
54"	(1) HQH5-3	8	(1) HQH5-3 (1) HQH1-3	4 Max Table Run	(1) HQH5-P	8 Max Table Run
60"	(1) HQH5-3	8	(1) HQH5-3 (1) HQH1-3	4 Max Table Run	(1) HQH5-P	8 Max Table Run
66"	(1) HQH5-3 (1) HQJ3	4	(1) HQH5-3 (1) HQH1-3	4 Max Table Run	(1) HQH5-P (1) HQJ3	4 Max Table Run
72"	(1) HQH5-3 (1) HQJ3	4	(1) HQH5-3 (1) HQH1-3	4 Max Table Run	(1) HQH5-P (1) HQJ3	4 Max Table Run
84"	(1) HQH5-3 (1) HQJ3	4	(2) HQH5-3	4 Max Table Run	(1) HQH5-P (1) HQJ3	4 Max Table Run
96"	(1) HQH5-3 (1) HQJ3	4	(2) HQH5-3	4 Max Table Run	(1) HQH5-P (1) HQJ3	4 Max Table Run
Half-Round (all sizes)	(1) HQH1-3	2	N/A	N/A	(1) HQH5-P	2
Trapezoid (all sizes)	(1) HQH5-3	8	N/A	N/A	(1) HQH5-P	8

NOTES:

- Interlink IQ Electrical is a pluggable, single circuit electrical system.
- All electrical models include wire management clips and hardware.
- Interlink IQ Electrical is non-sequential/non-directional. It can be installed in any direction.
- Interlink IQ Electrical is UL Recognized as a Powered Table System and meets the requirements of UL 962.

 40' maximum run, or no more than 8 units, whichever comes first. Interlink IQ system will automatically shut off if maximum requirements are exceeded. Maximum run is based upon electrical harness width, not table width.

HOW TO SPECIFY

Select Model Number

H
Q
J
3

TABLES

4-TRAC HARDWIRE ELECTRICAL SYSTEM

4-Trac Electrical System

The 4-Trac Electrical System is a UL-recognized Manufactured Wiring System that seamlessly passes power from one worksurface to another. This low-profile non-sequential electrical system allows tables to be “daisy-chained” together in any desired order and allows users to reconfigure quickly due to simple connectable/disconnectable links.

- Meets requirements of UL 183 and National Electric Code Article 604
- 4-Wires, 2-circuits, 20 Amps each (Circuit 1 and Circuit 2 only)
- 13 Duplex Receptacles per circuit, 26, 15 Amp Duplex receptacle per power in-feed
- Electrical system attaches directly to underside of worksurface with included brackets
- Up to twelve tables can be linked together

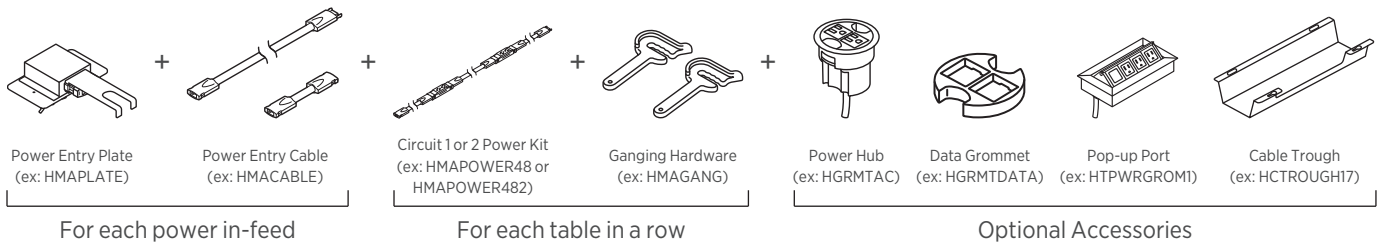

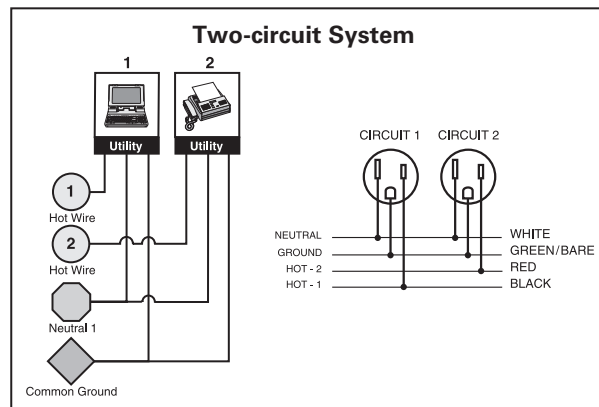
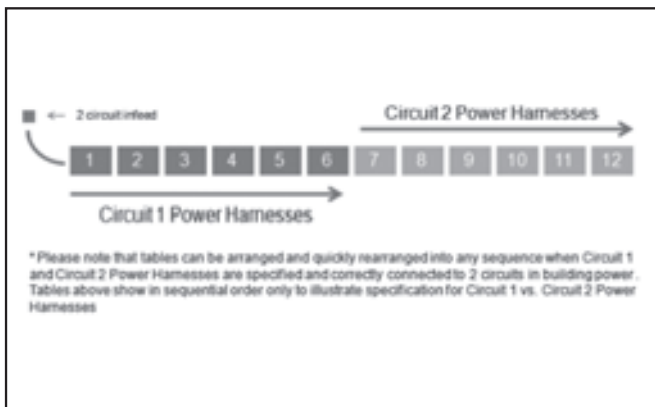

Steps for Electrical Specifications:

- Determine how many rows of tables are needed and order the following:
 - One HMAPLATE per row (or power in-feed)
 - One HMAPOWER48 per row (or power in-feed)
- Order one power harness per table in each row
 - For 1-6 tables in a row (see illustration 1)
 - Order Circuit 1 Power Harnesses (ex. If powering six 24x60 tables order six sets of HMAPOWER60)
 - For 7-12 tables in a row (see illustration 1)
 - Order Circuit 1 Power Harness for first six tables and Circuit 2 Power Harness for remaining tables (ex. If powering eight 24x60 tables, order six sets of HMAPOWER60 and two sets of HMAPOWER602)
- Order one set of ganging hardware per table (ex. HMAGANG)
- Determine which accessories are needed:
 - Power Hub model HGRMTAC — to access power at worksurface.
 - Data Grommet model HGRMTDATA — to access data at worksurface.
 - Wire Management strips model HBTMS — for vertical and horizontal wire management.

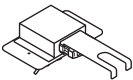
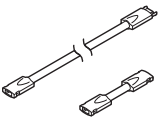

4-TRAC HARDWIRE ELECTRICAL SYSTEM

	DESCRIPTION	MODEL	SHIP WEIGHT	CUBE	LIST PRICE
	Power Entry Plate	HMAPLATE	1.0	0.2	\$93
	Power Entry Cable • 6' power entry cable with male/female adapter. • Connects table to power entry plate.	HMACABLE	1.8	0.2	\$144
	Power Jumper Cable To connect tables front to front	HMAJUMP	0.5	0.3	\$49
	Circuit 1 Power Kit for 48" W Table	HMAPOWER48	1.8	0.3	\$266
	Circuit 1 Power Kit for 60" W Table	HMAPOWER60	2.0	0.3	\$276
	Circuit 1 Power Kit for 72" W Table	HMAPOWER72	2.2	0.3	\$281
	Circuit 1 Power Kit for 84" W Table	HMAPOWER84	2.4	0.3	\$291
	Circuit 1 Power Kit for 96" W Table	HMAPOWER96	2.6	0.3	\$300
	Circuit 2 Power Kit for 48" W Table	HMAPOWER482	1.8	0.3	\$266
	Circuit 2 Power Kit for 60" W Table	HMAPOWER602	2.0	0.3	\$276
	Circuit 2 Power Kit for 72" W Table	HMAPOWER722	2.2	0.3	\$281
	Circuit 2 Power Kit for 84" W Table	HMAPOWER842	2.4	0.3	\$291
	Circuit 2 Power Kit for 96" W Table	HMAPOWER962	2.6	0.3	\$300

NOTES:

- Ganging Hardware must be ordered and installed on tables when using 4-trac electrical systems. See page 742 for Ganging Hardware.
- Each power kit includes two duplex receptacles and attaches to the underside of the worksurface with included brackets.

HOW TO SPECIFY

Select
Model Number

H M A P L A T E

HUDDLE

Power and Cable Management

GSA SIN AS NOTED



Icon Legend on page 19

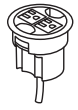

SIN 33721T

DESCRIPTION

Power Hub, 3" Grommet Mount, 6' Cord

- Fits in 3" round grommet holes.
- Field installed with Plug-and-play ease.
- Two grounded AC power outlets.
- Includes 6' cord with three-prong plug.
- Available in Black only. *Specify X when ordering. Example: HGRMTAC.X.*

NOTES: For additional information see page 848.

MODEL

HGRMTAC

SHIP WEIGHT

1.3

CUBE

0.2

LIST PRICE

\$111

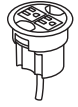

SIN 33721T

3" Round Power Grommet - 2 Outlets, 10' Cord

- Includes 10' cord with three-prong plug.
- Fits in 3" round grommet holes.
- Two grounded AC power outlets.
- Field installed with Plug-and-play ease.

NOTES: Power Modules will also work with standing-height applications for 10500 Series™ and Voi® desks.

- ! Available in black finish only, no specification needed.

HGRMTAC2

1.5

0.2

\$148



SIN 33721T

Power/USB Hub, 3" Grommet Mount

- One grounded AC power outlet with 2 USB ports.
- UL Listed.

NOTES: For additional information see page 848.

- ! Available in black only (no color designation so use .X - Specify: HGRMTUSB2.X).

HGRMTUSB2

1.3

0.2

\$224



SIN 33721



Pop-up Port

- Fits into 4" x 8" cutout.
- Specify G1 cutout in table top.
- Pop-up Port provides three power ports and one blank data receptacle.
- Sits flush with worksurface when closed.
- Finish is anodized aluminum.
- Includes 6' cord with three-prong plug.

NOTES: For additional information see page 850.

HTPWGRGOM1

5.0

0.3

\$392



SIN 33721

Data Grommet

Blank grommet kit that includes adapters for a variety of manufacturers jacks and couplers.

- Fits in existing 3" round grommet housing.
- Available in Black only. *Specify P when ordering. Example: HGRMTDATA.P.*

NOTES: For additional information see page 848.

HGRMTDATA

0.2

0.2

\$19

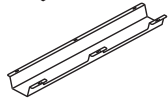
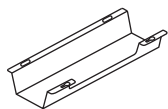

SIN 33721

Cable Management Troughs

- 17"W - Single
- 17"W - 10-Pack
- 36"W - Single
- 36"W - 10-Pack

- Cable management troughs ship flat packed.
- The troughs attach to underneath the worksurface with screws.
- Cutouts in trough allow access to power without the need to detach from surface. 17"W = 1 cutout; 36"W = 2 cutouts.
- Color: Graphite.
- Material: Metal.
- TAA Compliant.

NOTES: For additional information see page 852.

HCTROUGH17

2.7

0.5

\$67

HCTROUGH1710

14.0

0.5

\$620

HCTROUGH36

4.9

0.9

\$113

HCTROUGH3610

30.0

0.9

\$1045

HOW TO SPECIFY

Select Model Number

H G R M T A C

OCCASIONAL TABLES



Occasional Tables shown with Ceres® Seating.

TABLES

OCCASIONAL TABLES

Durable materials and construction make HON Occasional Tables ideal for high-traffic areas such as lobbies, reception areas and lounges. The versatile design also dresses up any corner of the executive office where casual, but important, conversations are held. Use them to hold lamps, magazines, courtesy phones and more. They're available in 14 woodgrain, patterned or solid color laminates to coordinate with any decor.



FEATURES

- A high-quality solution for any organization wanting to make a great impression on clients and visitors.
- Scratch-, spill- and stain-resistant laminate stands up to heavy use.
- Heavy-grade, warp-resistant particleboard features high recycled content.
- Complement many interiors and furniture designs.
- Brings people together comfortably in reception areas, lounges and offices.

LAMINATE OCCASIONAL TABLES OPTIONS

H80191, H80192, H80193

L1 LAMINATES CODES

Woodgrain

- ◆ Bourbon Cherry H
- ◆ Cognac COGN
- ◆ Florence Walnut LFW1
- ◆ Harvest C
- ◆ Kingswood Walnut LK11
- ◆ Mahogany N
- ◆ Mocha MOCH
- ◆ Natural Maple D
- ◆ Pinnacle PINC
- ◆ Shaker Cherry F
- ◆ Sterling Ash LSA1

Solid

- ◆ Black P
- ◆ Charcoal S
- ◆ Designer White LDW1
- ◆ Loft LOFT

Patterned Top*

- ◆ Canyon Zephyr K9
- ◆ Desert Zephyr K8
- ◆ Grey Tigris L6
- ◆ Sheer Mesh A5
- ◆ Silver Mesh A9

H80170, H80180

L1 LAMINATES CODES

Woodgrain

- ◆ Bourbon Cherry H
- ◆ Cognac COGN
- ◆ Florence Walnut LFW1
- ◆ Harvest C
- ◆ Kingswood Walnut LK11
- ◆ Mahogany N
- ◆ Mocha MOCH
- ◆ Natural Maple D
- ◆ Pinnacle PINC
- ◆ Shaker Cherry F
- ◆ Sterling Ash LSA1

Solid

- ◆ Black P
- ◆ Charcoal S
- ◆ Designer White LDW1
- ◆ Loft LOFT







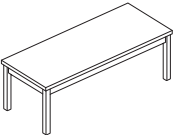

Two-Tone Options for Laminate Occasional Tables (H80191, H80192 and H80193)

Black/Charcoal (PS)	Harvest/Black (CP)
Black/Designer White (PLDW1)	Harvest/Charcoal (CS)
Bourbon Cherry/Black (HP)	Harvest/Designer White (CLDW1)
Bourbon Cherry/Charcoal (HS)	Kingswood Walnut/Black (LK11P)
Bourbon Cherry/Designer White (HLDW1)	Kingswood Walnut/Charcoal (LK11S)
Charcoal/Black (SP)	Kingswood Walnut/Designer White (LK11LDW1)
Charcoal/Designer White (SLDW1)	Kingswood Walnut/Loft (LK11LOFT)
Cognac/Black (COGNP)	Mahogany/Black (NP)
Cognac/Charcoal (COGNS)	Mahogany/Charcoal (NS)
Cognac/Designer White (COGNLDW1)	Mahogany/Designer White (NLDW1)
Designer White/Black (LDW1P)	Mocha/Black (MOCHP)
Designer White/Bourbon Cherry (LDW1H)	Mocha/Charcoal (MOCHS)
Designer White/Charcoal (LDW1S)	Mocha/Designer White (MOCHLDW1)
Designer White/Cognac (LDW1COGN)	Natural Maple/Black (DP)
Designer White/Harvest (LDW1C)	Natural Maple/Charcoal (DS)
Designer White/Mahogany (LDW1N)	Natural Maple/Designer White (DLDW1)
Designer White/Mocha (LDW1MOCH)	Pinnacle/Black (PINCP)
Designer White/Natural Maple (LDW1D)	Pinnacle/Charcoal (PINCS)
Designer White/Pinnacle (LDW1PINC)	Pinnacle/Designer White (PINCLDW1)
Designer White/Shaker Cherry (LDW1F)	Shaker Cherry/Black (FP)
Florence Walnut/Black (LFW1P)	Shaker Cherry/Charcoal (FS)
Florence Walnut/Charcoal (LFW1S)	Shaker Cherry/Designer White (FLDW1)
Florence Walnut/Designer White (LFW1LDW1)	Sterling Ash/Black (LSA1P)
Florence Walnut/Loft (LFW1LOFT)	Sterling Ash/Charcoal (LSA1S)
	Sterling Ash/Designer White (LSA1LDW1)

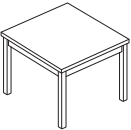
* NOTE: For patterned top laminates, select one of the following for the edgeband around the top, apron, and legs — Black (P), Bourbon Cherry (H), Charcoal (S), Cognac (COGN), Designer White (LDW1), Florence Walnut (LFW1), Harvest (C), Kingswood Walnut (LK11), Mahogany (N), Mocha (MOCH), Natural Maple (D), Pinnacle (PINC), Shaker Cherry (F), Sterling Ash (LSA1).

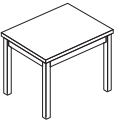
◆◆◆ For lead time information see page 19.

LAMINATE Occasional Tables

	DESCRIPTION	MODEL	SHIP WEIGHT	CUBE	LIST PRICE
 	Coffee Table 48"W x 20"D x 16"H	H80191	48 	3.4	\$475
 	Corner Table 24"W x 24"D x 20"H	H80192	35 	2.1	\$410
 	End Table 24"W x 20"D x 20"H	H80193	29 	1.8	\$392
	Cylinder Table 20" Diameter x 20"H	H80170	40	6.2	\$641
	Cube Table 24"W x 24"D x 20"H	H80180	55	8.6	\$695

TABLES

NOTES:

- Durable material and construction make laminate occasional tables ideal for high traffic areas such as lobbies, reception rooms and lounges. Versatile design is also well suited to private offices.
- Coffee, Corner and End Tables feature top-over-apron styling with square corner detail, which complements many interiors and furniture designs, including the 10500 Series.
- Tables accommodate lamps, magazines, telephones, plants, laptops and more.
- Tops are abrasion- and stain-resistant laminate over 1 1/8" thick solid core high-performance particleboard.
- Cylinder and cube tables have recessed black plinth base with tack glides. Tops and sides are covered with high-pressure laminate.



H80191, H80192, H80193
Edge Detail

HOW TO SPECIFY

Select Model Number	Select Laminate
	See page 748 for Select Laminate noted with each model
H 8 0 1 9 1 .	N N

LAMINATE

Contemporary Occasional Tables

OPEN MARKET



Icon Legend on page 19

	DESCRIPTION	MODEL	SHIP WEIGHT	CUBE	LIST PRICE
	Laminate Corner Table 24"W x 24"D x 17½"H	HML8851	24 Ⓢ	1.7	\$194
	Laminate Coffee Table 48"W x 24"D x 15½"H	HML8852	38 Ⓢ	3.1	\$244

NOTES:

- Choose from Corner or Coffee Table options.
- Silver frame.
- **HON 5-Year Limited Warranty.**
- ! Metal leg occasional tables available in Black laminate ONLY.

TABLES

HOW TO SPECIFY

<p>Select Model Number</p> <p>H M L 8 8 5 1 .</p>	<p>Select Laminate</p> <p>P Black</p> <p>P</p>
---	--

	DESCRIPTION	MODEL	SHIP WEIGHT	CUBE	LIST PRICE
	Coffee Table 42"W x 20"D x 16"H	HBLH3160	24 Ⓢ	3.0	\$298
	Corner Table 24"W x 24"D x 20"H	HBLH3170	9 Ⓢ	1.7	\$232

NOTES:

Square Edge Detail (Laminate)



- **HON 5-Year Limited Warranty.**
- Ideal for reception areas, lounges and offices.
- Laminate tops have a hollow core honeycomb substructure, making them extremely light weight.
- 2" thick top.
- Sleek contemporary design.
- Models HBLH3160 and HBLH3170 available in Black finish only.

HOW TO SPECIFY

<p>Select Model Number</p> <p>H B L H 3 1 6 0 .</p>	<p>Select Laminate</p> <p>P Black</p> <p>P</p>
---	--

MOTIVATE®



TABLES

Motivate® Tables and Chairs with Voi® Desks.

MOTIVATE®

Motivate tables were designed with flexible spaces in mind. Work patterns can change throughout the day. Task areas become collaborative areas. Learning areas become conference areas. Created for HON by designer Wolfgang Deisig, Motivate tables are mobile, lightweight and ready to support the many ways you work — adapting and reacting to your needs with ease. Because flexible spaces make for dynamic workplaces.



FEATURES

- 1½" thick solid core top is made from durable high-performance particleboard.
- Motivate Tables are available in three base options — fixed, nesting and height adjustable.
- Built-in modular power can be ganged together without any tools.
- Motivate Tables coordinate perfectly with Motivate chairs — an ideal fit for flexible spaces.

MOTIVATE® TABLES SPECIFYING INFORMATION

TABLES

LAMINATE

L1 LAMINATES CODES

- Woodgrain**
- ◆ Bourbon Cherry **H**
 - ◆ Cognac **COGN**
 - ◆ Florence Walnut **LFW1**
 - ◆ Harvest **C**
 - ◆ Kingswood Walnut **LK11**
 - ◆ Mahogany **N**
 - ◆ Mocha **MOCH**
 - ◆ Natural Maple **D**
 - ◆ Pinnacle **PINC**
 - ◆ Shaker Cherry **F**
 - ◆ Sterling Ash **LSA1**

- Solid**
- ◆ Black **P**
 - ◆ Charcoal **S**
 - ◆ Designer White **LDW1**
 - ◆ Loft **LOFT**

- Patterned**
- ◆ Sheer Mesh **A5**
 - ◆ Silver Mesh **B9**
 - ◆ Steel Mesh **A9**
 - ◆ Canyon Zephyr **K9**
 - ◆ Desert Zephyr **K8**
 - ◆ Shadow Zephyr **K1**
 - ◆ Gray **G2**
 - ◆ White **G1**
 - ◆ Whitestone **K4**

L2 LAMINATES CODES

- Woodgrain**
- ◆ Lowell Ash **LLA1**
 - ◆ Natural Recon **LNR1**
 - ◆ Phantom Ecu **LPE1**
 - ◆ Portico Teak **LPT1**
 - ◆ Skyline Walnut **LSW1**

EDGE BAND

EDGE BAND 2MM CODES

- ◆ Black **P**
- ◆ Bourbon Cherry **H**
- ◆ Charcoal **S**
- ◆ Cognac **COGN**
- ◆ Designer White **DW**
- ◆ Florence Walnut **FW**
- ◆ Greige **R**
- ◆ Harvest **C**
- ◆ Kingswood Walnut **KI**
- ◆ Loft **LOFT**
- ◆ Lowell Ash **DL**
- ◆ Mahogany **N**
- ◆ Mocha **MOCH**
- ◆ Muslin **T**
- ◆ Natural Maple **D**
- ◆ Natural Recon **NR**
- ◆ Phantom Ecu **PE**
- ◆ Pinnacle **PINC**
- ◆ Platinum **K**
- ◆ Portico Teak **DP**
- ◆ Shadow * **SHDW**
- ◆ Shaker Cherry **F**
- ◆ Skyline Walnut **SW**
- ◆ Sterling Ash **SA**

ERGO

ERGO-EDGE CODES

- ◆ Black **P**
- ◆ Platinum **K**

PAINT

PAINT CODES

- P1**
- ◆ Black **P**
 - ◆ Brownstone **P7D**
 - ◆ Charcoal **S**
 - ◆ Designer White **PJW**
 - ◆ Fossil **P28**
 - ◆ Greige **T5**
 - ◆ Loft **LOFT**
 - ◆ Muslin **T3**
 - ◆ Putty **L**
 - ◆ Textured Black **BLCK**
 - ◆ Titanium **P8T**
- P2**
- ◆ Champagne Metallic **T4**
 - ◆ Platinum Metallic **T1**
 - ◆ Silver **PR6**
 - ◆ Solar Black **P8X**
 - ◆ Textured Platinum **PLAT**
 - ◆ Textured Silver **PR8**
- P3**
- ◆ Atom **P8S**
 - ◆ Bullseye **PJF**
 - ◆ Ember **P8P**
 - ◆ Ion **P8N**
 - ◆ Iris **P8J**
 - ◆ Krypton **P8F**
 - ◆ Regatta **P8M**

Recommended Edgeband Color Selection:





Laminate		Edgeband	
Bourbon Cherry	H	Bourbon Cherry	H
Cognac	COGN	Cognac	COGN
Florence Walnut	LFW1	Florence Walnut	FW
Harvest	C	Harvest	C
Kingswood Walnut	LK11	Kingswood Walnut	KI
Mahogany	N	Mahogany	N
Mocha	MOCH	Mocha	MOCH
Natural Maple	D	Natural Maple	D
Pinnacle	PINC	Pinnacle	PINC
Shaker Cherry	F	Shaker Cherry	F
Sterling Ash	LSA1	Sterling Ash	SA
Black	P	Black	P
Charcoal	S	Charcoal	S
Designer White	LDW1	Designer White	DW
Whitestone	K4	Muslin	T
Sheer Mesh	A5	Muslin	T
Silver Mesh	B9	Loft	LOFT
Steel Mesh	A9	Charcoal	S
Canyon Zephyr	K9	Greige	R
Desert Zephyr	K8	Greige	R
Shadow Zephyr	K1	Loft	LOFT
Gray	G2	Charcoal	S
White	G1	Charcoal	S
Lowell Ash	LLA1	Lowell Ash	DL
Natural Recon	LNR1	Natural Recon	NR
Phantom Ecu	LPE1	Phantom Ecu	PE
Portico Teak	LPT1	Portico Teak	DP
Skyline Walnut	LSW1	Skyline Walnut	SW
Loft	LOFT	Loft	LOFT

◆◆◆ For lead time information see page 19.
* De-emphasized



Icon Legend on page 19

MOTIVATE® Fixed Height Tables

DESCRIPTION	MODEL	SHIP WEIGHT	CUBE	LIST PRICE BY LAMINATE GRADE			
				"G" 2MM EDGE		"R" ERGO EDGE	
				L1	L2	L1	L2
Rectangular Tables, Fixed Base							
 72"W x 18"D	HMVR-1872(?) -FX	80	6.6	\$945	\$960	\$1253	\$1268
60"W x 18"D	HMVR-1860(?) -FX	70	6.0	\$869	\$884	\$1136	\$1151
48"W x 18"D	HMVR-1848(?) -FX	54	5.3	\$861	\$871	\$1101	\$1111
 96"W x 24"D	HMVR-2496(?) -FX	118	8.8	\$1211	\$1236	N/A	N/A
84"W x 24"D	HMVR-2484(?) -FX	109	8.1	\$1161	\$1186	N/A	N/A
72"W x 24"D	HMVR-2472(?) -FX	96	7.3	\$965	\$985	\$1288	\$1308
66"W x 24"D	HMVR-2466(?) -FX	90	7.3	\$946	\$966	N/A	N/A
60"W x 24"D	HMVR-2460(?) -FX	83	6.6	\$924	\$944	\$1217	\$1237
54"W x 24"D	HMVR-2454(?) -FX	71	6.6	\$907	\$927	N/A	N/A
48"W x 24"D	HMVR-2448(?) -FX	65	5.8	\$887	\$902	\$1149	\$1164
42"W x 24"D	HMVR-2442(?) -FX	60	5.4	\$867	\$882	N/A	N/A
36"W x 24"D	HMVR-2436(?) -FX	54	5.1	\$852	\$867	N/A	N/A
96"W x 30"D	HMVR-3096(?) -FX	145	10.7	\$1311	\$1336	N/A	N/A
84"W x 30"D	HMVR-3084(?) -FX	131	10.7	\$1299	\$1324	N/A	N/A
72"W x 30"D	HMVR-3072(?) -FX	115	9.8	\$1051	\$1071	\$1394	\$1414
66"W x 30"D	HMVR-3066(?) -FX	108	9.8	\$1022	\$1042	N/A	N/A
60"W x 30"D	HMVR-3060(?) -FX	100	8.9	\$997	\$1017	\$1312	\$1332
54"W x 30"D	HMVR-3054(?) -FX	87	8.9	\$976	\$996	N/A	N/A
48"W x 30"D	HMVR-3048(?) -FX	80	7.9	\$964	\$979	\$1240	\$1255
42"W x 30"D	HMVR-3042(?) -FX	73	7.4	\$941	\$956	N/A	N/A
36"W x 30"D	HMVR-3036(?) -FX	65	6.9	\$921	\$936	N/A	N/A
72"W x 36"D	HMVR-3672(?) -FX	131	10.8	\$1204	\$1229	N/A	N/A
60"W x 36"D	HMVR-3660(?) -FX	114	9.7	\$1116	\$1141	N/A	N/A
48"W x 36"D	HMVR-3648(?) -FX	91	9.7	\$1043	\$1063	N/A	N/A
Half-Round Tables, Fixed Base							
 72"W x 36"D	HMVH-3672(?) -FX	103	10.8	\$1254	\$1279	N/A	N/A
60"W x 30"D	HMVH-3060(?) -FX	75	7.6	\$977	\$1002	\$1312	\$1337
48"W x 24"D	HMVH-2448(?) -FX	56	5.8	\$912	\$932	\$1195	\$1215
Trapezoid Tables, Fixed Base							
 72"W x 36"D	HMVT-3672(?) -FX	91	10.8	\$1275	\$1300	N/A	N/A
60"W x 30"D	HMVT-3060(?) -FX	66	7.6	\$986	\$1011	\$1326	\$1351
48"W x 24"D	HMVT-2448(?) -FX	56	5.8	\$931	\$951	\$1216	\$1236

TABLES

NOTES:

- Specification includes top and base, however, top and base are boxed separately.
- Ergo edge is a bullnose on user side and 3mm on all other sides.
- Tops are 1½" thick.
- Fixed Height base is standard 29½" worksurface height.
- See grommet matrix on page 758 for grommet location/placement.
- 36"-42" tops and all half-round and trapezoid tops standard with one 3" round grommet, 48"-96" tops standard with two 3" round grommets. When G1 grommet is selected, all tops standard with one cutout.

Edge Treatments

• HOW TO ORDER

- 1) Select desired model numbers.
- 2) Select desired top edge treatment.
- 3) Replace the (?) after each model number with the suffix representing the chosen top edge treatment.



"G" 2MM Edge



"R" Ergo Edge

HOW TO SPECIFY

Select Model Number	Select Grommet Option	Select Laminate	Select Edge Color	Select Caster/Glide Option	Select Base Paint Color
	<p>N No Grommet</p> <p>G Grommet (\$15 upcharge PER grommet)</p> <p>G1 Electrical Port (\$40 upcharge)</p>	See page 752	See page 752	<p>C Multi-Surface Caster</p> <p>G Glide</p>	See page 752 \$20 upcharge per model, for P2 paint
HMVR-1872G-FX	N	C	C	T	C



MOTIVATE® Nesting Tables

GSA SIN 33721



Icon Legend on page 19

TABLES

DESCRIPTION	MODEL	SHIP WEIGHT	CUBE	LIST PRICE BY LAMINATE GRADE				
				"G" 2MM EDGE		"R" ERGO EDGE		
				L1	L2	L1	L2	
Rectangular Nesting Tables								
 72"W x 18"D	HMVR-1872(?) -NS	90	8.5	\$1244	\$1259	\$1552	\$1567	
60"W x 18"D	HMVR-1860(?) -NS	79	7.6	\$1164	\$1179	\$1415	\$1430	
48"W x 18"D	HMVR-1848(?) -NS	60	6.5	\$1159	\$1169	\$1394	\$1404	
96"W x 24"D	HMVR-2496(?) -NS	134	11.4	\$1490	\$1515	N/A	N/A	
84"W x 24"D	HMVR-2484(?) -NS	122	10.4	\$1460	\$1485	N/A	N/A	
72"W x 24"D	HMVR-2472(?) -NS	106	9.2	\$1264	\$1284	\$1587	\$1607	
66"W x 24"D	HMVR-2466(?) -NS	100	9.1	\$1241	\$1261	N/A	N/A	
60"W x 24"D	HMVR-2460(?) -NS	92	8.2	\$1219	\$1239	\$1512	\$1532	
54"W x 24"D	HMVR-2454(?) -NS	80	8.2	\$1206	\$1226	N/A	N/A	
48"W x 24"D	HMVR-2448(?) -NS	73	7.2	\$1180	\$1195	\$1442	\$1457	
42"W x 24"D	HMVR-2442(?) -NS	67	6.6	\$1162	\$1177	N/A	N/A	
36"W x 24"D	HMVR-2436(?) -NS	60	6.3	\$1145	\$1160	N/A	N/A	
96"W x 30"D	HMVR-3096(?) -NS	161	13.3	\$1631	\$1656	N/A	N/A	
84"W x 30"D	HMVR-3084(?) -NS	144	13.0	\$1619	\$1644	N/A	N/A	
72"W x 30"D	HMVR-3072(?) -NS	125	11.7	\$1371	\$1391	\$1714	\$1734	
66"W x 30"D	HMVR-3066(?) -NS	118	11.6	\$1338	\$1358	N/A	N/A	
60"W x 30"D	HMVR-3060(?) -NS	109	10.5	\$1313	\$1333	\$1614	\$1634	
54"W x 30"D	HMVR-3054(?) -NS	96	10.5	\$1296	\$1316	N/A	N/A	
48"W x 30"D	HMVR-3048(?) -NS	88	9.3	\$1278	\$1293	\$1554	\$1569	
42"W x 30"D	HMVR-3042(?) -NS	80	8.1	\$1257	\$1272	N/A	N/A	
36"W x 30"D	HMVR-3036(?) -NS	71	8.1	\$1235	\$1250	N/A	N/A	
72"W x 36"D	HMVR-3672(?) -NS	141	12.7	\$1524	\$1549	N/A	N/A	
60"W x 36"D	HMVR-3660(?) -NS	123	11.3	\$1432	\$1457	N/A	N/A	
48"W x 36"D	HMVR-3648(?) -NS	99	11.1	\$1357	\$1377	N/A	N/A	
Half-Round Nesting Tables								
 72"W x 36"D	HMVH-3672(?) -NS	111	12.2	\$1568	\$1593	N/A	N/A	
60"W x 30"D	HMVH-3060(?) -NS	82	8.8	\$1352	\$1377	\$1687	\$1712	
48"W x 24"D	HMVH-2448(?) -NS	62	7.0	\$1205	\$1225	\$1488	\$1508	
Trapezoid Nesting Tables								
 72"W x 36"D	HMVT-3672(?) -NS	98	12.0	\$1591	\$1616	N/A	N/A	
60"W x 30"D	HMVT-3060(?) -NS	72	8.8	\$1279	\$1304	\$1606	\$1631	
48"W x 24"D	HMVT-2448(?) -NS	57	7.0	\$1232	\$1252	\$1509	\$1529	

NOTES:

- Ergo edge is a bullnose on user side and 3mm on all other sides.
- Tops are 1 1/8" thick.
- Specification includes top and base, however, top and base are boxed separately.
- See grommet matrix on page 758 for grommet location/placement.
- 36"-42" tops and all half-round and trapezoid tops standard with one 3" round grommet, 48"-96" tops standard with two 3" round grommets. When G1 grommet is selected, all tops standard with one cutout.

Edge Treatments

- HOW TO ORDER
- 1) Select desired model numbers.
- 2) Select desired top edge treatment.
- 3) Replace the (?) after each model number with the suffix representing the chosen top edge treatment.



"G" 2MM Edge





"R" Ergo Edge

HOW TO SPECIFY

<p>Select Model Number</p> <p>HMVR-1872G-NS</p>	<p>Select Grommet Option</p> <p>N No Grommet G Grommet (\$15 upcharge PER grommet) G1 Electrical Port (\$40 upcharge)</p> <p>N</p>	<p>Select Laminate</p> <p>See page 752</p> <p>C</p>	<p>Select Edge Color</p> <p>See page 752</p> <p>C</p>	<p>Select Caster/Glide Option</p> <p>C Multi-Surface Caster G Glide</p> <p>C</p>	<p>Select Base Paint Color</p> <p>See page 752 \$20 upcharge per model, for P2 paint</p> <p>T1</p>
--	---	--	--	---	---

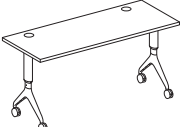

MOTIVATE® Adjustable Height Tables

DESCRIPTION	MODEL	SHIP WEIGHT	CUBE	LIST PRICE BY LAMINATE GRADE			
				"G" 2MM EDGE		"R" ERGO EDGE	
				L1	L2	L1	L2
 Rectangular Tables, Adjustable Height Base 72"W x 18"D 60"W x 18"D 48"W x 18"D	HMVR-1872(?) -AH	83	6.6	\$1231	\$1246	\$1539	\$1554
	HMVR-1860(?) -AH	73	6.0	\$1155	\$1170	\$1422	\$1437
 72"W x 24"D 66"W x 24"D 60"W x 24"D 54"W x 24"D 48"W x 24"D 42"W x 24"D 36"W x 24"D	HMVR-2472(?) -AH	99	7.3	\$1251	\$1271	\$1574	\$1594
	HMVR-2466(?) -AH	93	7.3	\$1232	\$1252	N/A	N/A
72"W x 30"D 66"W x 30"D 60"W x 30"D 54"W x 30"D 48"W x 30"D 42"W x 30"D 36"W x 30"D	HMVR-3072(?) -AH	118	9.8	\$1358	\$1378	\$1701	\$1721
	HMVR-3066(?) -AH	111	9.8	\$1329	\$1349	N/A	N/A
72"W x 36"D 60"W x 36"D 48"W x 36"D	HMVR-3060(?) -AH	103	8.9	\$1304	\$1324	\$1619	\$1639
	HMVR-3054(?) -AH	90	8.9	\$1283	\$1303	N/A	N/A
72"W x 36"D 60"W x 36"D 48"W x 36"D	HMVR-3048(?) -AH	83	7.9	\$1271	\$1286	\$1547	\$1562
	HMVR-3042(?) -AH	76	7.4	\$1248	\$1263	N/A	N/A
72"W x 36"D 60"W x 36"D 48"W x 36"D	HMVR-3036(?) -AH	68	6.9	\$1228	\$1243	N/A	N/A
	HMVR-3672(?) -AH	134	10.8	\$1511	\$1536	N/A	N/A
72"W x 36"D 60"W x 36"D 48"W x 36"D	HMVR-3660(?) -AH	117	9.7	\$1423	\$1448	N/A	N/A
	HMVR-3648(?) -AH	94	9.7	\$1350	\$1370	N/A	N/A

TABLES

NOTES:

- Ergo edge is a bullnose on user side and 3mm on all other sides.
 - Tops are 1/8" thick.
 - Specification includes top and base, however, top and base are boxed separately.
 - Seated height adjustment from 27 1/2" - 32 1/2" in 1" increments.
 - See grommet matrix on page 758 for grommet location/placement.
 - 36"-42" tops and all half-round and trapezoid tops standard with one 3" round grommet, 48"-96" tops standard with two 3" round grommets. When G1 grommet is selected, all tops standard with one cutout.
- !** No tool required, adjustable bases have ratchet style adjustment mechanism.

Edge Treatments

HOW TO ORDER

- 1) Select desired model numbers.
- 2) Select desired top edge treatment.
- 3) Replace the (?) after each model number with the suffix representing the chosen top edge treatment.



"G" 2MM Edge



"R" Ergo Edge

HOW TO SPECIFY

<p>Select Model Number</p>	<p>Select Grommet Option</p> <p>N No Grommet G Grommet (\$15 upcharge PER grommet) G1 Electrical Port (\$40 upcharge)</p>	<p>Select Laminate</p> <p>See page 752</p>	<p>Select Edge Color</p> <p>See page 752</p>	<p>Select Caster/Glide Option</p> <p>C Multi-Surface Caster G Glide</p>	<p>Select Base Paint Color</p> <p>See page 752 \$20 upcharge per model, for P2 paint</p>
<p>H M V R - 1 8 7 2 G - A H .</p>	<p>N .</p>	<p>C .</p>	<p>C .</p>	<p>C .</p>	<p>P .</p>

MOTIVATE® Shared Components

GSA SIN 33721



Icon Legend on page 19

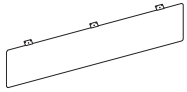

DESCRIPTION	MODEL	SHIP WEIGHT	CUBE	LIST PRICE BY PAINT GRADE	
				P1	P2
Universal Modesty Panel					
For 96"W Motivate® Tables	HMTUMOD86	21	4.8	\$280	\$300
For 84"W Motivate® Tables	HMTUMOD74	20	4.4	\$269	\$289
For 72"W Motivate® Tables	HMTUMOD62	17	3.6	\$259	\$279
For 66"W Motivate® Tables	HMTUMOD56	16	3.4	\$251	\$271
For 60"W Motivate® Tables	HMTUMOD50	14	3.1	\$242	\$262
For 54"W Motivate® Tables	HMTUMOD44	12	2.5	\$231	\$251
For 48"W Motivate® Tables	HMTUMOD38	11	2.2	\$220	\$240
For 42"W Motivate® Tables	HMTUMOD32	9	1.9	\$211	\$231
For 36"W Motivate® Tables	HMTUMOD26	8	1.7	\$202	\$222

NOTES:

- Modesty Panels are hinged to nest along with Nesting Tables. Modesty Panels can be used with all base types.
- ! Use field installed Table Modesty Panels with all table widths 36"-96". Cannot be used with Half-Round or Trapezoid tables.

TABLES

HOW TO SPECIFY

<p>Select Model Number</p>	<p>Select Paint Color</p> <p>See page 752 \$20 upcharge per model, for P2 paint</p>
<div style="display: flex; gap: 5px;"> <div style="border: 1px solid black; padding: 2px;">H</div> <div style="border: 1px solid black; padding: 2px;">M</div> <div style="border: 1px solid black; padding: 2px;">T</div> <div style="border: 1px solid black; padding: 2px;">U</div> <div style="border: 1px solid black; padding: 2px;">M</div> <div style="border: 1px solid black; padding: 2px;">O</div> <div style="border: 1px solid black; padding: 2px;">D</div> <div style="border: 1px solid black; padding: 2px;">8</div> <div style="border: 1px solid black; padding: 2px;">6</div> </div>	<div style="border: 1px solid black; padding: 2px; display: inline-block;">T1</div>



Icon Legend on page 19

MOTIVATE® Shared Components

TABLES

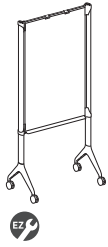

DESCRIPTION

Mobile
36"W x 72"H
30"W x 72"H
Actual size: HMVMB-3672WW -
36¼"W x 42"H HMVMB-3072WW -
30¼"W x 42"H

MODEL

HMVMB-3672WW
HMVMB-3072WW

SHIP WEIGHT

59
53

CUBE

7.9
7.1

LIST PRICE

\$1468
\$1442

NOTES: 2-Sided Mobile is porcelain over steel with four locking casters. Mobile includes marker tray and flip-chart paper clips.
Porcelain cleaning instructions: For everyday cleaning, use Clorox wipes. Use a citrus cleaner if a permanent marker is used by accident.
A citrus cleaner is not recommended for everyday use as it leaves residue.

\$20 list upcharge for P2 paint.
Specify Model.Base.Casters.Paint SPECIFYING EXAMPLE: HMVMB-3072WW.C.P

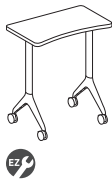

Presentation Cart, Concave Front, Fixed Leg

18"D x 30"W x 35"H, 2mm Edge
18"D x 30"W x 35"H, Ergo Edge

HMVPCF-1830G
HMVPCF-1830R

38
38

3.9
3.9

\$901
\$1220

NOTES: Presentation Cart tops are 1⅝" thick with a concave user side. Choose from a 2mm or Ergo edge.

\$10 list upcharge for L2 laminates.
Specify Model.Caster.TopLaminate.EdgeColor.Paint SPECIFYING EXAMPLE: HMVPCF-1830G.C.D.D.TI



Presentation Cart, Concave Front, Seated Height Adjustable-Leg

18"D x 30"W x 27½"-34½"H, 2mm Edge
18"D x 30"W x 27½"-34½"H, Ergo Edge

HMVPCA1-1830G
HMVPCA1-1830R

40
40

3.9
3.9

\$1188
\$1522

NOTES: Presentation Cart tops are 1⅝" thick with a concave user side. Choose from a 2mm or Ergo edge.

\$10 list upcharge for L2 laminates.
Specify Model.Caster.TopLaminate.EdgeColor.Paint SPECIFYING EXAMPLE: HMVPCA1-1830G.C.D.D.TI

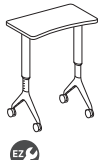

Presentation Cart, Concave Front, Standing-Height Adjustable-Leg

18"D x 30"W x 31½"-38½"H, 2mm Edge
18"D x 30"W x 31½"-38½"H, Ergo Edge

HMVPCA2-1830G
HMVPCA2-1830R

42
42

3.9
3.9

\$1188
\$1522

NOTES: Presentation Cart tops are 1⅝" thick with a concave user side. Choose from a 2mm or Ergo edge.

\$10 list upcharge for L2 laminates.
Specify Model.Caster.TopLaminate.EdgeColor.Paint SPECIFYING EXAMPLE: HMVPCA1-1830G.C.D.D.TI



Presentation Cart, Modesty Panel

Specify Model.Paint SPECIFYING EXAMPLE: HMVPC-MP.P

HMVPC-MP

6

1.4

\$183

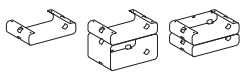

Presentation Cart, Storage Shelves

Single, 4" Open Back
Double, 4" Open Back / 4" Closed Back
Double, 4" Open Back / 9" Closed Back
Single, 4" Closed Back
Double, 4" Closed Back / 4" Closed Back
Double, 4" Closed Back / 9" Closed Back

HMVPCSS-40
HMVPCSS-404C
HMVPCSS-409C
HMVPCSS-4C
HMVPCSS-4C4C
HMVPCSS-4C9C

8
17
20
9
18
21

1.4
2.6
3.6
1.4
2.6
3.6

\$93
\$191
\$298
\$101
\$199
\$306

NOTES: Storage Shelves for Presentation Carts are available in three preconfigured sizes and may be used on fixed or adjustable height models.

Specify Model.Paint SPECIFYING EXAMPLE: HMVPCSS-40.TI

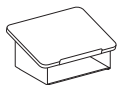

OPEN MARKET

Presentation Cart Desk Top Lectern, 2mm Edge

NOTES: Desk Top Lectern may be used on the Presentation Cart or is removable for use on table tops.

\$15 list upcharge for L2 laminates.
Desktop Lectern only available with 2mm edge.
Specify Model.LaminateTop.EdgeColor.Paint SPECIFYING EXAMPLE: HMVPC-DTLG.D.D.TI

HMVPC-DTLG

16

2.4

\$343





HOW TO SPECIFY

Select Model Number

H M V M B - 3 6 7 2 W W

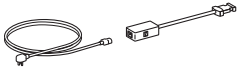
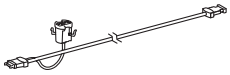
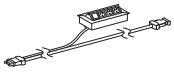
INTERLINK IQ ELECTRICAL

Icon Legend on page 19

	DESCRIPTION	MODEL	SHIP WEIGHT	CUBE	LIST PRICE
	Power Base In-Feed • 12 amp circuit breaker is built in to the Power Base In-Feed	HQB	2.0 \$	0.2	\$520
	Power Harness – 1' Power Hub, 3'' Round Grommet Mount	HQH1-3	2.0 \$	0.2	\$169
	Power Harness – 5' Power Hub, 3'' Round Grommet Mount	HQH5-3	2.0 \$	0.2	\$190
	Power Harness – 5' with 4'' x 8'' Pop-Up Port	HQH5-P	3.0 \$	0.3	\$370
	Power Jumper – 3'	HQJ3	2.0 \$	0.2	\$105
	Ganging Hardware • Includes two ganging links and two screws • No color designator when specifying. <i>Example: HMAGANG.</i>	HMAGANG	1.0 \$	0.1	\$89
	Cable Management Troughs 17"W – Single 17"W – 10-Pack NOTES: For additional information see page 852.	HCTROUGH17 HCTROUGH1710	2.7 \$ 14.0 \$	0.5 0.5	\$67 \$620

TABLES

Specification guide for IQ Electrical on Motivate® tables

Determine table width, the type of power access being used (3" grommet or 4x8 pop-up) and the desired number per table (Columns 1, 2 or 3). The table will then identify the type and quantity of components needed per table along with the maximum table run. Note that this is in addition to the Power base in-feed which is needed for each run. For example, a 48"W table with two 3" power grommets per table will require (1) HQH5-3 harness and (1) HQH1-3 harness per table with a maximum run of four tables.

Top Width	POWER ONE (1) PER TABLE 3" ROUND POWER GROMMET		POWER TWO (2) PER TABLE 3" ROUND POWER GROMMETS		POWER ONE (1) PER TABLE 4x8 POP-UP PORT	
	Component	Quantity	Component	Quantity	Component	Quantity
36"	(1) HQH5-3	8 Table Run Maximum	N/A	N/A	(1) HQH5-P	8 Max Table Run
42"	(1) HQH5-3	8 Table Run Maximum	N/A	N/A	(1) HQH5-P	8 Max Table Run
48"	(1) HQH5-3	8 Table Run Maximum	(1) HQH5-3 (1) HQH1-3	4 Max Table Run	(1) HQH5-P	8 Max Table Run
54"	(1) HQH5-3	8 Table Run Maximum	(1) HQH5-3 (1) HQH1-3	4 Max Table Run	(1) HQH5-P	8 Max Table Run
60"	(1) HQH5-3	8 Table Run Maximum	(1) HQH5-3 (1) HQH1-3	4 Max Table Run	(1) HQH5-P	8 Max Table Run
66"	(1) HQH5-3 (1) HQJ3	4 Table Run Maximum	(1) HQH5-3 (1) HQH1-3	4 Max Table Run	(1) HQH5-P (1) HQJ3	4 Max Table Run
72"	(1) HQH5-3 (1) HQJ3	4 Table Run Maximum	(1) HQH5-3 (1) HQH1-3	4 Max Table Run	(1) HQH5-P (1) HQJ3	4 Max Table Run
84"	(1) HQH5-3 (1) HQJ3	4 Table Run Maximum	(2) HQH5-3	4 Max Table Run	(1) HQH5-P (1) HQJ3	4 Max Table Run
96"	(1) HQH5-3 (1) HQJ3	4 Table Run Maximum	(2) HQH5-3	4 Max Table Run	(1) HQH5-P (1) HQJ3	4 Max Table Run
Half-Round (all sizes)	(1) HQH1-3	2 Tables Maximum	N/A	N/A	(1) HQH5-P	2 Max Table Run
Trapezoid (all sizes)	(1) HQH5-3	8 Table Run Maximum	N/A	N/A	(1) HQH5-P	8 Max Table Run

NOTES:

- Interlink IQ Electrical is a pluggable, single circuit electrical system.
- All electrical models include wire management clips and hardware.
- Interlink IQ Electrical is non-sequential/non-directional.
- Interlink IQ Electrical is UL Recognized as a Powered Table System and meets the requirements of UL 962 when paired with Motivate® or Huddle tables.

❗ 40' maximum run, or no more than 8 units, whichever comes first. Interlink IQ system will automatically shut off if maximum requirements are exceeded. Maximum run is based upon electrical harness width, not table width.

HOW TO SPECIFY

Select
Model Number

H Q J 3

4-TRAC HARDWIRE ELECTRICAL SYSTEM

4-Trac Electrical System

The 4-Trac Electrical System is a UL-recognized Manufactured Wiring System that seamlessly passes power from one worksurface to another. This low-profile non-sequential electrical system allows tables to be “daisy-chained” together in any desired order and allows users to reconfigure quickly due to simple connectable/disconnectable links.

- Meets requirements of UL 183 and National Electric Code Article 604
- 4-Wires, 2-circuits, 20 Amps each (Circuit 1 and Circuit 2 only)
- 13 Duplex Receptacles per circuit, 26, 15 Amp Duplex receptacle per power in-feed
- Electrical system attaches directly to underside of worksurface with included brackets
- Up to twelve tables can be linked together

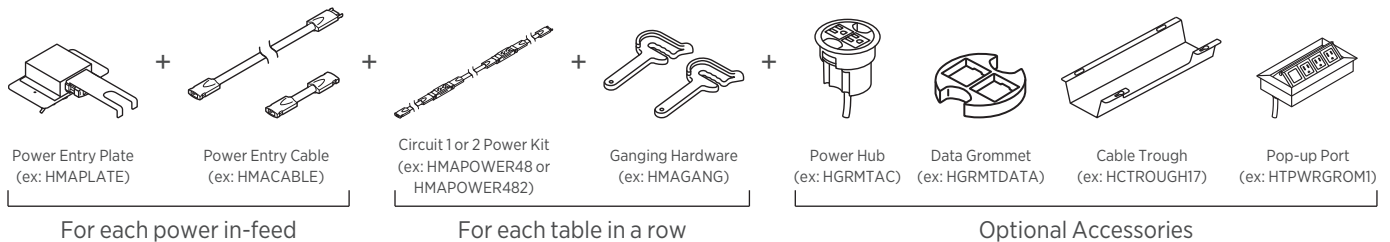

TABLES

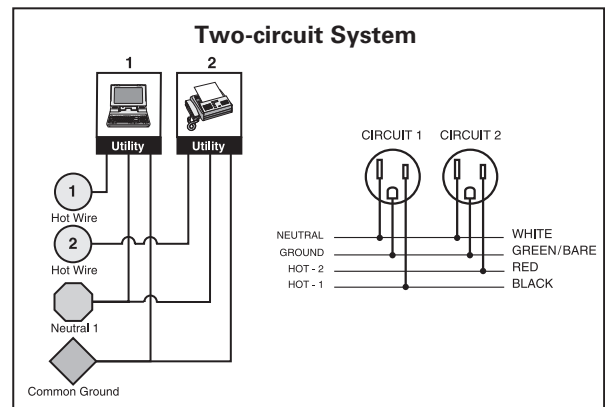
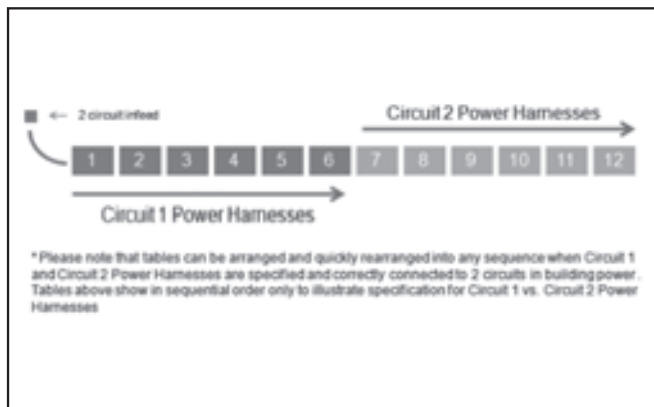

Steps for Electrical Specifications:

- Determine how many rows of tables are needed and order the following:
 - One HMAPLATE per row (or power in-feed)
 - One HMAPOWER60 per row (or power in-feed)
- Order one power harness per table in each row
 - For 1-6 tables in a row (see illustration 1)
 - Order Circuit 1 Power Harnesses (ex. If powering six 24x60 tables order six sets of HMAPOWER60)
 - For 7-12 tables in a row (see illustration 1)
 - Order Circuit 1 Power Harness for first six tables and Circuit 2 Power Harness for remaining tables (ex. If powering eight 24x60 tables, order six sets of HMAPOWER60 and two sets of HMAPOWER602)
- Order one set of ganging hardware per table (ex. HMAGANG)
- Determine which accessories are needed:
 - Power Hub model HGRMTAC — to access power at worksurface.
 - Data Grommet model HGRMTDATA — to access data at worksurface.
 - Wire Management strips model HBTMS — for vertical and horizontal wire management.

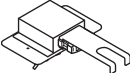
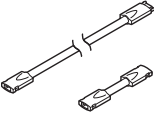

4-TRAC HARDWIRE ELECTRICAL SYSTEM

Icon Legend on page 19

	DESCRIPTION	MODEL	SHIP WEIGHT	CUBE	LIST PRICE
	Power Entry Plate	HMAPLATE	1.0	0.2	\$93
	Power Entry Cable • 6' power entry cable with male/female adapter. • Connects table to power entry plate.	HMACABLE	1.8	0.2	\$144
	Power Jumper Cable To connect tables front to front	HMAJUMP	0.5	0.3	\$49
	Circuit 1 Power Kit for 36" W Table	HMAPOWER36	1.5	0.3	\$261
	Circuit 1 Power Kit for 42" W Table	HMAPOWER42	1.8	0.3	\$264
	Circuit 1 Power Kit for 48" W Table	HMAPOWER48	1.8	0.3	\$266
	Circuit 1 Power Kit for 54" W Table	HMAPOWER54	2.0	0.3	\$272
	Circuit 1 Power Kit for 60" W Table	HMAPOWER60	2.0	0.3	\$276
	Circuit 1 Power Kit for 66" W Table	HMAPOWER66	2.2	0.3	\$279
	Circuit 1 Power Kit for 72" W Table	HMAPOWER72	2.2	0.3	\$281
	Circuit 1 Power Kit for 84" W Table	HMAPOWER84	2.4	0.3	\$291
	Circuit 1 Power Kit for 96" W Table	HMAPOWER96	2.6	0.3	\$300
	Circuit 2 Power Kit for 36" W Table	HMAPOWER362	1.5	0.3	\$261
	Circuit 2 Power Kit for 42" W Table	HMAPOWER422	1.8	0.3	\$264
	Circuit 2 Power Kit for 48" W Table	HMAPOWER482	1.8	0.3	\$266
	Circuit 2 Power Kit for 54" W Table	HMAPOWER542	2.0	0.3	\$272
	Circuit 2 Power Kit for 60" W Table	HMAPOWER602	2.0	0.3	\$276
Circuit 2 Power Kit for 66" W Table	HMAPOWER662	2.2	0.3	\$279	
Circuit 2 Power Kit for 72" W Table	HMAPOWER722	2.2	0.3	\$281	
Circuit 2 Power Kit for 84" W Table	HMAPOWER842	2.4	0.3	\$291	
Circuit 2 Power Kit for 96" W Table	HMAPOWER962	2.6	0.3	\$300	

NOTES:

- Each power kit includes two duplex receptacles and attaches to the underside of the worksurface with included brackets.
- Power Kits are compatible with various base types including nesting bases.

HOW TO SPECIFY







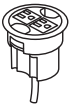
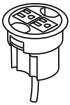

Select
Model Number

HMAPLATE

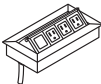
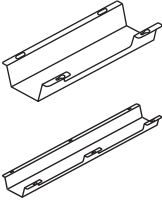

Icon Legend on page 19

OPTIONAL ELECTRICAL ACCESSORIES

	DESCRIPTION	MODEL	SHIP WEIGHT	CUBE	LIST PRICE
 SIN 33721T	Power Hub, 3" Grommet Mount, 6' Cord <ul style="list-style-type: none"> Fits in 3" round grommet holes. Field installed with Plug-and-play ease. Two grounded AC power outlets. Includes 6' cord with three-prong plug. Available in Black only. <i>Specify X when ordering. Example: HGRMTAC.X.</i> <p>NOTES: For additional information see page 848.</p>	HGRMTAC	1.3	0.2	\$111
 SIN 33721T 	3" Round Power Grommet - 2 Outlets, 10' Cord <ul style="list-style-type: none"> Includes 10' cord with three-prong plug. Fits in 3" round grommet holes. Two grounded AC power outlets. Field installed with Plug-and-play ease. <p>NOTES: Power Modules will also work with standing-height applications for 10500 Series™ and Voi® desks.  Available in black finish only, no specification needed.</p>	HGRMTAC2	1.5	0.2	\$148
	Data Grommet Blank grommet kit that includes adapters for a variety of manufacturers jacks and couplers. <ul style="list-style-type: none"> Fits in existing 3" round grommet housing. Available in Black only. <i>Specify P when ordering. Example: HGRMTDATA.P.</i> <p>NOTES: For additional information see page 848.</p>	HGRMTDATA	0.2	0.2	\$19
	Pop-up Port <ul style="list-style-type: none"> Fits into 4" x 8" cutout. Pop-up Port provides three power ports and one blank data receptacle. Sits flush with worksurface when closed. Finish is anodized aluminum. Includes 6' cord with three-prong plug. <p>NOTES: For additional information see page 850.</p>	HTPWRGROM1	5.0	0.3	\$392
	Cable Management Troughs 17"W — Single 17"W — 10-Pack 36"W — Single 36"W — 10-Pack <ul style="list-style-type: none"> Cable management troughs ship flat packed. The troughs attach to underneath the worksurface with screws. Cutouts in trough allow access to power without the need to detach from surface. 17"W = 1 cutout; 36"W = 2 cutouts. Color: Graphite. Material: Metal. TAA Compliant. <p>NOTES: For additional information see page 852.</p>	HCTROUGH17 HCTROUGH1710 HCTROUGH36 HCTROUGH3610	2.7  14.0  4.9  30.0 	0.5 0.5 0.9 0.9	\$67 \$620 \$113 \$1045

TABLES

HOW TO SPECIFY

Select Model Number

H T P W R G R O M 1

NOTES

TABLES

PRESIDE®



TABLES

Preside® Table and Presentation Cabinet shown with Ignition® 2.0 Seating.

The Preside® series has added new products that are not featured in this pricer. Please [click here](#) to see the full pricer with all of the new products.

PRESIDE®

Versatility. Productivity. Endless possibilities. Preside is one of the broadest collections we offer. From cozy café tables to conference rooms for 20, it provides the perfect balance of selection and style — a high-value solution for those who need maximum performance on a budget. Tech friendly and available in tons of shapes and sizes, Preside makes it easy for people and ideas to connect.



FEATURES

- Preside offers a complete line of conference accessories, including presentation cabinets, hospitality, buffet or modular credenzas and more.
- Optional flip-top and pop-up ports provide options today and for future data and power needs.
- Scratch-, spill- and stain-resistant laminate stands up to heavy use.
- High-value solution for organizations wanting maximum performance on a budget.

PRESIDE® ORDERING INFORMATION

LAMINATE

L1 LAMINATES CODES

Woodgrain

- ◆ Bourbon Cherry H
- ◆ Cognac COGN
- ◆ Florence Walnut LFW1
- ◆ Harvest C
- ◆ Kingswood Walnut LK11
- ◆ Mahogany N
- ◆ Mocha MOCH
- ◆ Natural Maple D
- ◆ Pinnacle PINC
- ◆ Shaker Cherry F
- ◆ Sterling Ash LSA1

Solid

- ◆ Black* P
- ◆ Charcoal* S
- ◆ Designer White* LDW1
- ◆ Loft* LOFT

Patterned

- ◆ Sheer Mesh** A5
- ◆ Silver Mesh** B9
- ◆ Steel Mesh** A9
- ◆ Canyon Zephyr** K9
- ◆ Desert Zephyr** K8
- ◆ Gray** G2
- ◆ Grey Tigris** L6
- ◆ White** G1
- ◆ Whitestone* K4

L2 LAMINATES CODES

Woodgrain

- ◆ Lowell Ash LLA1
- ◆ Natural Recon LNR1
- ◆ Phantom Ecreu LPE1
- ◆ Portico Teak LPT1
- ◆ Skyline Walnut LSW1

PAINT

PAINT CODES

P1

- ◆ Black P
- ◆ Charcoal S
- ◆ Designer White PJW
- ◆ Loft*** LOFT

P2

- ◆ Champagne Metallic* T4
- ◆ Platinum Metallic T1
- ◆ Silver PR6

Exceptions:

* Not available on hollow panel base endcap/inlay.

** Not available on Tables Bases, Credenza Chassis, Modular Credenza, Presentation Cabinet, and Lectern.

*** Not available on Aluminum bases.

◆◆◆ For lead time information see page 19.

PRESIDE® SPECIFYING INFORMATION

EDGE BAND OPTIONS	CODES	2mm (G)	Knife (J)	T-Mold (E)	Traditional (T)
Bourbon Cherry	H	•	•		
Cognac	COGN	•	•		
Harvest	C	•	•		
Mahogany	N	•	•		•
Mocha	MOCH	•	•		
Natural Maple	D	•	•		
Shaker Cherry	F	•	•		
Sterling Ash	SA	•	•		
Black	P	•	•	•	
Charcoal	S	•	•	•	
Designer WHIT	DW	•	•	•	
Greige	R	•	•	•	
Loft	LOFT	•	•	•	
Muslin	T	•	•	•	
Pinnacle	PINC	•	•		
Platinum	K	•	•	•	
Lowell Ash	DL	•	•	•	
Natural Recon	NR	•	•	•	
Phantom Ecrú	PE	•	•	•	
Portico Teak	DP	•	•	•	
Skyline Walnut	SW	•	•	•	

Recommended Edgeband Color Selection:

Laminate		Edge	
Bourbon Cherry	H	Bourbon Cherry	H
Cognac	COGN	Cognac	COGN
Florence Walnut	LFW1	Florence Walnut	FW
Harvest	C	Harvest	C
Kingswood Walnut	LK11	Kingswood Walnut	KI
Mahogany	N	Mahogany	N
Mocha	MOCH	Mocha	MOCH
Natural Maple	D	Natural Maple	D
Pinnacle	PINC	Pinnacle	PINC
Shaker Cherry	F	Shaker Cherry	F
Sterling Ash	LSA1	Sterling Ash	SA
Black	P	Black	P
Charcoal	S	Charcoal	S
Designer White	LDW1	Designer White	DW
Loft	LOFT	Loft	LOFT
Whitestone	K4	Muslin	T
Sheer Mesh	A5	Muslin	T
Silver Mesh	B9	Loft	LOFT
Steel Mesh	A9	Charcoal	S
Canyon Zephyr	K9	Greige	R
Desert Zephyr	K8	Greige	R
Shadow Zephyr	K1	Loft	LOFT
Gray	G2	Charcoal	S
Grey Tigris	L6	Greige	R
White	G1	Charcoal	S
Lowell Ash	LLA1	Lowell Ash	DL
Natural Recon	LNR1	Natural Recon	NR
Phantom Ecrú	LPE1	Phantom Ecrú	PE
Portico Teak	LPT1	Portico Teak	DP
Skyline Walnut	LSW1	Skyline Walnut	SW

PRESIDE® SPECIFYING INFORMATION

Statement of Line

TOP SHAPES

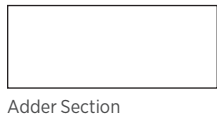
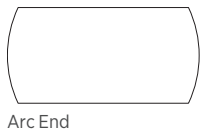
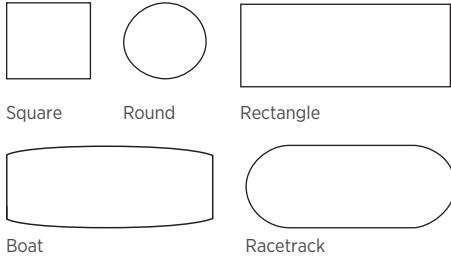

TOP EDGE PROFILES

For Laminate Tops

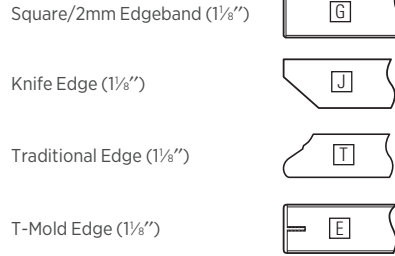

TABLES

BASES

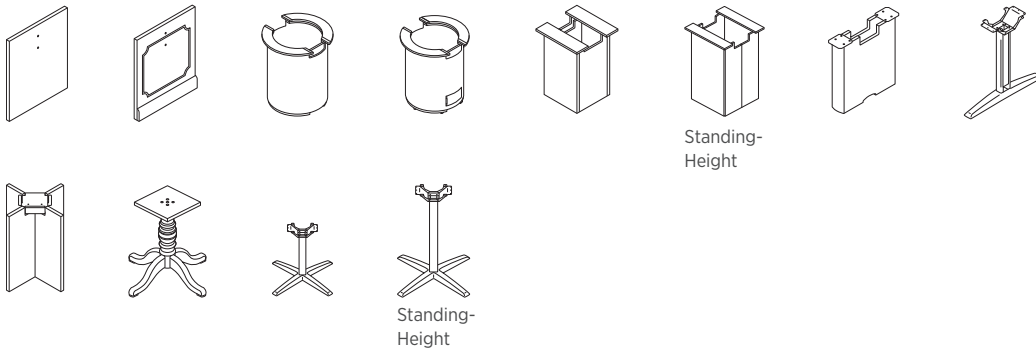

ANCILLARY COMPONENTS

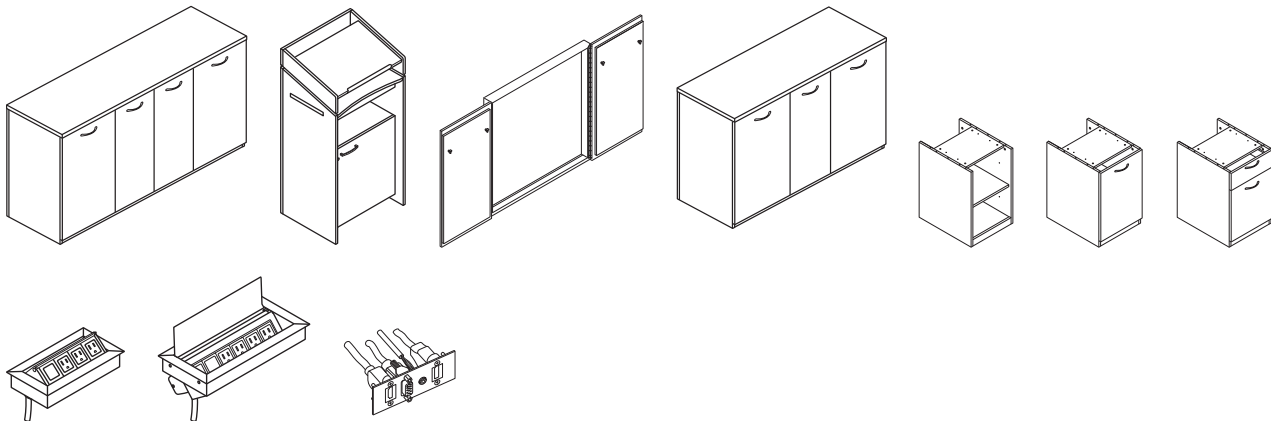









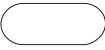



PRESIDE[®] SPECIFYING INFORMATION

Preside conference tops come in single-piece or multi-piece sections depending on specified size. See below for top sizes, sections, and suggested seating capacity.





Product Reference: Sizes, Sections, Seating Capacity

Multi-piece tops: Rectangle, Racetrack, Boat and Arc End Tops









	Feet	Inches	30"D	36"D	48"D	54"D	Suggested Capacity
	30	360"			6 6 6 6 6	6 6 6 6 6	28-30
	28	336"			5 6 6 6 5	5 6 6 6 5	26-28
	26	312"			7 6 6 7	7 6 6 7	24-26
	24	288"			6 6 6 6	6 6 6 6	22-24
	22	264"			5 6 6 5	5 6 6 5	20-22
	20	240"			7 6 7	7 6 7	18-20
	18	216"			6 6 6	6 6 6	16-18
	16	192"			5 6 5	5 6 5	14-16
	15	180"			4½ 6 4½	4½ 6 4½	14-16
	14	168"			7 7	7 7	12-14
	12	144"			6 6	6 6	10-12
	10	120"			5 5	5 5	8-10
	9	108"			4½ 4½	4½ 4½	8-10

TABLES

Single-piece tops: Rectangle, Racetrack, Boat and Arc End Tops

	Feet	Inches	30"D	36"D	42"D	48"D	Suggested Capacity
	8	96"				8	6-8
	7	84"			7		4-6
	6	72"		6			4-6
	5	60"	5				4-6

Single-piece tops: Round and Square

		36"	42"	48"	Suggested Capacity
	Round				2-4
	Square				2-4

Notes: Single- and two-piece tops ship in one carton, three-piece tops ship in two cartons.
Three-piece tops and larger will not contain grain match for all pieces.

PRESIDE® SPECIFYING INFORMATION

Preside Base Compatibility

Bases compatible with 48"D and 54"D Rectangle, Boat, Racetrack and Arc End Tops

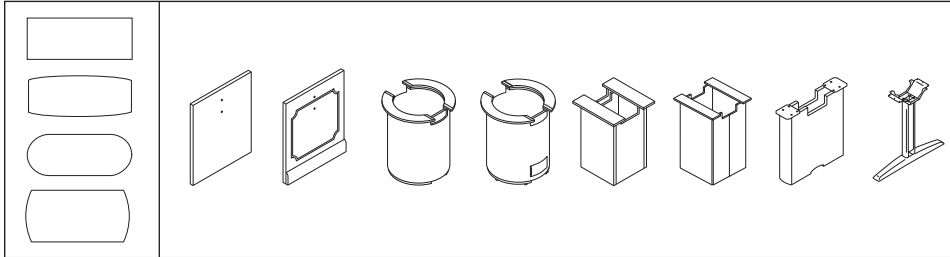

Bases compatible with 30"D and 36"D Rectangle, Boat, Racetrack, Soft Wedge, Arc End and Peninsula Tops

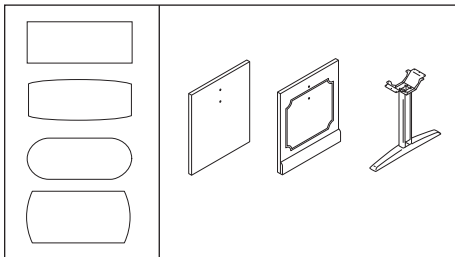

Bases compatible with Round and Square Tops

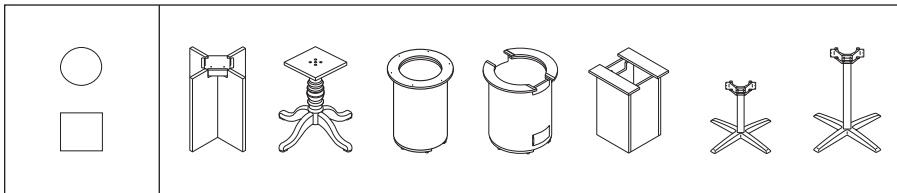

Bases that accommodate power and data

Power and data can be routed through select bases. Bases with removable doors provide easy access to concealed cabling and technology, such as wireless internet routers.

Bases with door accessibility

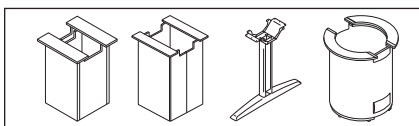

Bases with wire routing capabilities

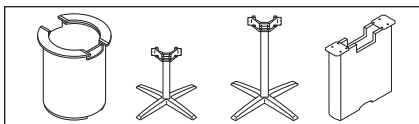

PRESIDE® SPECIFYING INFORMATION

Specify Preside tables with two steps—select a top and select a base.

1. Select desired top size, shape, and edge profile.

Multi-piece Tops:

Multi-piece tops are made of 108", 120", 144" and 168" two-piece "starter-sections" in rectangle, boat, arc end, or racetrack shapes in 48" or 54" depths. For tables up to 20', models are preconfigured for you. If you need a table top longer than 20', add as many 72" adder sections as you need. The examples below illustrate preconfigured sizes as well as how starter section and adder section tops can be used to create tables in virtually any length.

Please note that 2-piece tops, in woodgrain colors, will not have exact grain alignment in the center where the two halves meet, a reasonable match can be expected. For tops utilizing an adder section, there will not be a grain match for those pieces.

Preconfigured and Modular Size Examples

	Feet	Inches	Ex. Top Starter Section	Quantity	Adder Section	Quantity	Total Number of Top Sections
Preconfigured Sizes	9'	108"	HTLC48108	1	n/a	n/a	2
	10'	120"	HTLC48120	1	n/a	n/a	2
	12'	144"	HTLC48144	1	n/a	n/a	2
	14'	168"	HTLC48168	1	n/a	n/a	2
	15'	180"	HTLC48180	1	n/a	n/a	3
	16'	192"	HTLC48192	1	n/a	n/a	3
	18'	216"	HTLC48216	1	n/a	n/a	3
	20'	240"	HTLC48240	1	n/a	n/a	3
Modular Sizes	22'	264"	HTLC48120	1	HTLM4872	2	4
	24'	288"	HTLC48144	1	HTLM4872	2	4
	26'	312"	HTLC48168	1	HTLM4872	2	4
	28'	336"	HTLC48120	1	HTLM4872	3	5
	30'	360"	HTLC48144	1	HTLM4872	3	5

Note: Tables can be configured to any desired length beyond 30' in 6' increments.

Illustrations of Preconfigured Tops

48" x 108" Table Top (9')

54"	54"
-----	-----

Ex: HTLC48108

48" x 120" Table Top (10')

60"	60"
-----	-----

Ex: HTLC48120

48" x 144" Table Top (12')

72"	72"
-----	-----

Ex: HTLC48144

48" x 168" Table Top (14')

84"	84"
-----	-----

Ex: HTLC48168

48" x 180" Table Top (15')

54"	72"	54"
-----	-----	-----

Ex: HTLC48180

48" x 192" Table Top (16')

60"	72"	60"
-----	-----	-----

Ex: HTLC48192

48" x 216" Table Top (18')

72"	72"	72"
-----	-----	-----

Ex: HTLC48216

48" x 240" Table Top (20')

84"	72"	84"
-----	-----	-----

Ex: HTLC48240

Illustrations of User Configured Modular Tops

48" x 72" Adder Section

72"

Ex: HTLM4872

48"D x 360"W Table Top (30')

72"	72"	72"	72"	72"
-----	-----	-----	-----	-----

Ex: HTLC48144 + HTLM4872 + HTLM4872 + HTLM4872

PRESIDE® SPECIFYING INFORMATION

2. Select desired base style and identify model that coincides with top length.

Bases for Tops in Preconfigured Sizes

Bases include the appropriate number of supports for tables up to 20'. Simply identify the length of the table top in inches and specify the base with the same length in the model number. The example below illustrates how to select a base for a preconfigured size top.

Examples of Base for Preconfigured Top Size

Example top: HTLC48240 Top Description: 240" Rectangle Top
 Example base: HTLHP240 Base Description: Hollow Panel Base for 240" Top

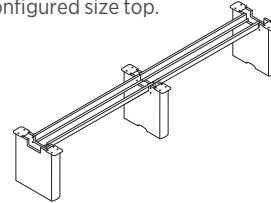

Example: HTLHP240

Bases for Tops in User Configured Modular Sizes

If you need a table top longer than 20', add as many 72" adder section bases as needed. The examples below illustrate preconfigured sizes as well as how starter section and adder section bases can be used to create tables in any desired length.

Examples of Tops and Bases for User Configured Modular Top

	Feet	Inches	Ex. Top Starter Section	Quantity	Ex. Top Adder Section	Quantity	Ex. Base Starter Section	Quantity	Ex. Base Adder Section	Quantity	Total # of Top Sections
Preconfigured Sizes	9'	108"	HTLC48108	1	n/a	n/a	HTLHP108	1	n/a	n/a	2
	10'	120"	HTLC48120	1	n/a	n/a	HTLHP120	1	n/a	n/a	2
	12'	144"	HTLC48144	1	n/a	n/a	HTLHP144	1	n/a	n/a	2
	14'	168"	HTLC48168	1	n/a	n/a	HTLHP168	1	n/a	n/a	2
	15'	180"	HTLC48180	1	n/a	n/a	HTLHP180	1	n/a	n/a	3
	16'	192"	HTLC48192	1	n/a	n/a	HTLHP192	1	n/a	n/a	3
	18'	216"	HTLC48216	1	n/a	n/a	HTLHP216	1	n/a	n/a	3
	20'	240"	HTLC48240	1	n/a	n/a	HTLHP240	1	n/a	n/a	3
Modular Sizes	22'	264"	HTLC48120	1	HTLM4872	2	HTLHP120	1	HTLHPM	2	4
	24'	288"	HTLC48144	1	HTLM4872	2	HTLHP144	1	HTLHPM	2	4
	26'	312"	HTLC48168	1	HTLM4872	2	HTLHP168	1	HTLHPM	2	4
	28'	336"	HTLC48120	1	HTLM4872	3	HTLHP120	1	HTLHPM	3	5
	30'	360"	HTLC48144	1	HTLM4872	3	HTLHP144	1	HTLHPM	3	5

Note: Tables can be configured to any desired length beyond 30' in 6' increments.

Note: Preconfigured bases include the appropriate number of supports for tables up to 20'. Depending on base type, number of required supports varies. For information regarding total number of supports please refer to chart below.

Feet	Inches	HTLP	HTLT	HTTLEG	HTLHP	HTLCUBE	HTLCUBES	HTLR	HTLRC
9'	108"	2	2	2	2	2	2	2	2
10'	120"	2	2	2	2	2	2	2	2
12'	144"	2	2	2	2	2	2	2	2
14'	168"	3	3	3	3	2	2	2	2
15'	180"	3	n/a	3	3	3	3	3	3
16'	192"	3	n/a	3	3	3	3	3	3
18'	216"	3	n/a	3	3	3	3	3	3
20'	240"	4	n/a	4	3	3	3	3	3

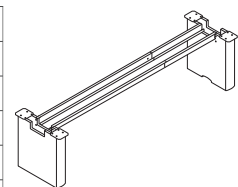

Example: HTHLP168

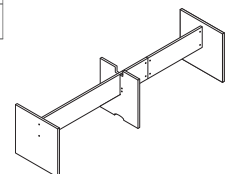

Example: HTLP168

Base Model Descriptions

HTLP = Panel Base
 HTLT = Traditional Panel Base
 HTTLEG = Aluminum T-Leg
 HTLHP = Hollow Panel Base
 HTLCUBE = Cube Base
 HTLCUBES = Standing-Height Cube Base
 HTLR = Cylinder Base
 HTLRC = Wire Management Cylinder Base

Note: Laminate panel bases configured with particleboard stretcher supports.

PRESIDE® Grommet Cutout Placement

Tops specified with a grommet cutout get one cutout per section of top, centered in both directions. Cutouts do not include blank or powered inserts. Inserts must be specified separately.

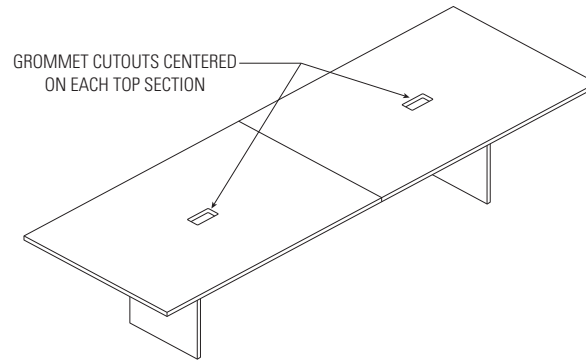

Upcharges for grommet cutouts (\$40 per G1 cutout, \$50 per G2 cutout)

Top Width	# Cutouts	Upcharge (G1/G2)	# Power Ports Required
36"	1	\$ 40/50	1
42"	1	\$ 40/50	1
48"	1	\$ 40/50	1
60"	1	\$ 40/50	1
72"	1	\$ 40/50	1
84"	1	\$ 40/50	1
96"	1	\$ 40/50	1
108"	2	\$ 80/100	2
120"	2	\$ 80/100	2
144"	2	\$ 80/100	2
168"	2	\$ 80/100	2
180"	3	\$120/150	3
192"	3	\$120/150	3
216"	3	\$120/150	3
240"	3	\$120/150	3

PRESIDE® Base Clearance Dimensions

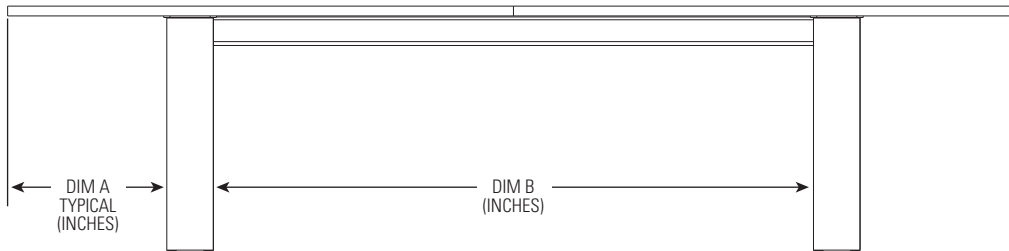

Clearance Between Bases for Tables 60''W and 72''W

Model #	Description	5' (60'')		6' (72'')	
		Dim. A	Dim. B	Dim. A	Dim. B
HTLPA	Panel Base	11	36	17	36
HTLTA	Traditional Panel Base	n/a	n/a	17	36
HTTLEG	Aluminum T-Leg	12	29	14	37

Clearance Between Bases for Tables 84''W-240''W

Model #	Description	7' / 8' (84'' / 96'')		9' / 10' (108'' / 120'')		12' (144'')		14' (168'')		15' / 16' (180'' / 192'')		18' (216'')		20' (240'')	
		Dim. A	Dim. B	Dim. A	Dim. B	Dim. A	Dim. B	Dim. A	Dim. B	Dim. A	Dim. B	Dim. A	Dim. B	Dim. A	Dim. B
HTLHPB	Hollow Panel Base	13/19	47	13/19	71	19	95	19	57	13/19	69	19	81	19	93
HTLPB	Panel Base	17/23	48	17/23	72	23	96	23	60	17/23	72	23	84	23	63
HTLRB	Cylinder Base	13/19	14	13/19	38	19	62	19	86	13/19	44	19	56	19	68
HTLRBC	Cylinder Base with Wire Management	13/19	14	13/19	38	19	62	19	86	13/19	44	19	56	19	68
HTLSB	Cube Base	13/19	18	13/19	42	19	66	19	90	13/19	47	19	59	19	71
HTLSH	Standing-Height Cube Base*	13/19	13	13/19	42	19	61	19	85	13/19	42	19	54	19	66
HTLTB	Traditional Panel Base	17/23	48	17/23	72	23	96	23	60	n/a	n/a	n/a	n/a	n/a	n/a
HTTLEG	Aluminum T-Leg	14/20	47	14/20	72	20	96	20	58	14/20	72	20	84	20	96

*Not Applicable to 84'' Tops.

Preside conference solutions can be used in a multitude of office applications.

42"D Round Top, 2mm Edge, Cylinder Base

Laminate Pricing:

QTY	MODEL	LIST PRICE	PRICE EXTENSION
1	HTLD42.G	\$477	\$477
1	HTLR42	\$695	\$695
TOTAL:			\$1,172



FOR THE PRIVATE OFFICE

48"D x 48"W Square Top, Knife Edge, Cube Base

Laminate Pricing:

QTY	MODEL	LIST PRICE	PRICE EXTENSION
1	HTLS48.J	\$874	\$874
1	HTLCUBE48	\$1,001	\$1,001
TOTAL:			\$1,875

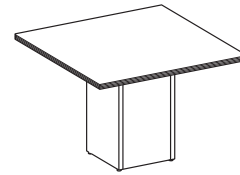

FOR THE PRIVATE OFFICE

240"W x 54"D Rectangle Top, Knife Edge, 3 Cutouts, 3 Flip-Top Ports, Cube Base

Laminate Pricing:

QTY	MODEL	LIST PRICE	PRICE EXTENSION
3	HTPWRGROM2	\$579	\$1,737
1	HTLCUBE240	\$3,647	\$3,647
1	HTLC5440.J.G2	\$4,748	\$4,748
TOTAL:			\$10,132

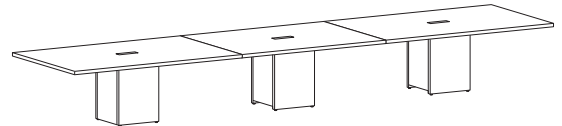

FOR THE BOARDROOM

PRESIDE® Laminate Table Tops

GSA SIN 33721



Icon Legend on page 19

TABLES

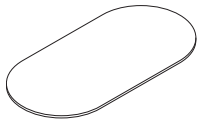

A = Racetrack
Not available in "T" edge option

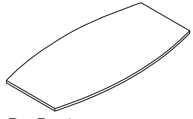

B = Boat
Not available in "T" edge option

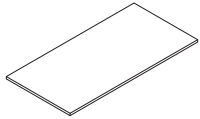

C = Rectangle

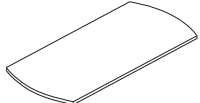

E = Arc End
Not available in "T" edge option

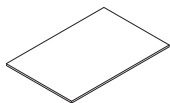

M = Mid-section Adder

DESCRIPTION	MODEL	SHIP WEIGHT	CUBE	LIST PRICE BY EDGE TREATMENT				L2 UPCHARGE
				"E"	"G"	"J"	"T"	
Laminate Boat, Racetrack, Rectangle and Arc End Shaped Tops								
240"W x 54"D	HTL(?)54240	425	25.1	N/A	\$2793	\$4598	N/A	\$125
216"W x 54"D	HTL(?)54216	384	23.3	N/A	\$2439	\$3913	N/A	\$105
192"W x 54"D	HTL(?)54192	345	21.4	N/A	\$2272	\$3713	N/A	\$100
180"W x 54"D	HTL(?)54180	442	21.4	N/A	\$2272	\$3713	N/A	\$100
168"W x 54"D	HTL(?)54168	300	13.5	\$1735	\$1883	\$3002	N/A	\$85
144"W x 54"D	HTL(?)54144	259	11.6	\$1416	\$1529	\$2317	N/A	\$65
120"W x 54"D	HTL(?)54120	220	9.8	\$1257	\$1362	\$2117	N/A	\$60
108"W x 54"D	HTL(?)54108	324	9.8	\$1257	\$1362	\$2117	N/A	\$60
Laminate Boat, Racetrack, Rectangle and Arc Shaped Tops								
240"W x 48"D	HTL(?)48240	392	21.9	N/A	\$2268	\$3734	N/A	\$105
216"W x 48"D	HTL(?)48216	351	19.7	N/A	\$1984	\$3190	N/A	\$90
192"W x 48"D	HTL(?)48192	312	18.1	N/A	\$1853	\$3030	N/A	\$85
180"W x 48"D	HTL(?)48180	300	18.6	N/A	\$1853	\$3030	N/A	\$85
168"W x 48"D	HTL(?)48168	281	12.1	\$1387	\$1507	\$2400	\$3858	\$70
144"W x 48"D	HTL(?)48144	240	9.8	\$1133	\$1223	\$1856	\$3349	\$55
120"W x 48"D	HTL(?)48120	201	8.2	\$1007	\$1092	\$1696	\$2712	\$50
108"W x 48"D	HTL(?)48108	203	9.8	\$1007	\$1092	\$1696	N/A	\$50
96"W x 48"D	HTL(?)4896	153	13.2	\$854	\$885	\$1354	\$2092	\$50
84"W x 42"D	HTL(?)4284	157	12.1	\$854	\$885	\$1354	N/A	\$40
72"W x 36"D	HTL(?)3672	90	7.9	\$569	\$623	\$1030	\$1091	\$30
60"W x 30"D	HTL(?)3060	63	5.6	\$450	\$493	\$829	N/A	\$20
Laminate Adder Section for Boat, Racetrack, Rectangle and Arc Shaped Tops								
72"W x 54"D	HTLM5472	125	11.6	N/A	\$910	\$1596	N/A	\$40
72"W x 48"D	HTLM4872	111	9.8	N/A	\$761	\$1334	N/A	\$35

! Adder section cannot be used as stand-alone table. Only long edges are finished.

NOTES:

- See base options on pages 776-779.
- Tops greater than 96" ship in multiple pieces to facilitate handling and installation. For details see page 767.
- Tops with E, G, and T edge details feature durable laminate tops over solid core high-performance particleboard. Tops with J edge feature an MDF core.
- Laminate tops with traditional (T) edge feature high gloss laminate and wood edge to coordinate with 94000 Series Desks.
- Table tops sit 29½" above floor with glide half way seated.
- Tops with E edge detail have 3" radius corners. All other edge details have 90 degree corners.
- Optional cutouts are available to accommodate power ports. One centered cutout per top section. Power ports must be ordered separately. For power port specification details see page 788.
- See page 771 for number of cutouts for each table top size.
- Single and two-piece tops ship in one carton, three piece tops ship in two cartons.
- ! Tops with traditional edge available in Mahogany only.
- ! Two-piece tops in woodgrain colors will not have exact grain alignment in the center where the two halves meet, a reasonable match can be expected. 3-piece or more tops will not contain any grain match.

HOW TO SPECIFY

<p>Select Model Number</p> <p><i>For laminate tops with traditional (T) edge, place a "T" at the end of the base model.</i></p> <p>HTLC3060 .</p> <p>Traditional Edge</p> <p>HTLC3672T .</p>	<p>Select Edge Detail and Edge Color</p> <p>See pages 765-766</p> <p><i>For laminate tops with traditional (T) edge, select edge color ONLY.</i></p> <p>JC .</p> <p>N .</p>	<p>Select Cutout Option</p> <p>N No Cutout</p> <p>G1 Cutout for Pop-up Port (\$40 upcharge per cutout)</p> <p>G2 Cutout for Flip-top Port (\$50 upcharge per cutout) Flip-top Port cannot be specified for Round or Square tops</p> <p>G2 .</p> <p>G2 .</p>	<p>Select Laminate</p> <p>See page 764</p> <p>D</p> <p>N</p>
--	--	--	---



PRESIDE® Laminate Table Tops



D = Round

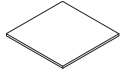

S = Square

DESCRIPTION	MODEL	SHIP WEIGHT			LIST PRICE BY EDGE TREATMENT				L2 UPCHARGE	
		ROUND	SQUARE	CUBE	"E"	"G"	"J"	"T"		
Laminate Round and Square Shaped Tops										
48" Top	HTL(?)48	66	76	6.3	\$489	\$529	\$874	\$992	\$25	
42" Top	HTL(?)42	51	61	4.9	\$434	\$477	\$813	\$868	\$20	
36" Top	HTL(?)36	36	46	3.7	\$381	\$440	\$696	\$782	\$20	

NOTES: Tops are available in two shapes: Round (D) and Square (S). Replace the (?) shown in each model with D or S to specify shape.

NOTES:

- See base options on pages 776-779.
- Tops 96" and greater, in woodgrain colors, will not have exact grain alignment in the center where the two halves meet, a reasonable match can be expected.
- Tops greater than 96" ship in multiple pieces to facilitate handling and installation. For details see page 767.
- Tops with E, G, and T edge details feature durable laminate tops over solid core high-performance particleboard. Tops with J edge feature an MDF core.
- Laminate tops with traditional (T) edge feature high gloss laminate and wood edge to coordinate with 94000 Series Desks.
- Table tops sit 29½" above floor with glide half way seated.
- Tops with E edge detail have 3" radius corners. All other edge details have 90 degree corners.
- Optional cutouts are available to accommodate power ports. One centered cutout per top section. Power ports must be ordered separately. For power port specification details see page 788.
- See page 771 for number of cutouts for each table top size.
- Single and two-piece tops ship in one carton, three piece tops ship in two cartons.
- ! Tops with traditional edge available in Mahogany only.

TABLES

HOW TO SPECIFY

Select Model Number	Select Edge Detail and Edge Color	Select Cutout Option	Select Laminate
<p>See pages 765-766</p> <p>HTLD48</p> <p>Traditional Edge</p> <p>HTLD48T</p>	<p>See pages 765-766</p> <p>JC</p> <p>N</p>	<p>No Cutout</p> <p>G1 Cutout for Pop-up Port (\$40 upcharge per cutout)</p> <p>G2 Cutout for Flip-top Port (\$50 upcharge per cutout) Flip-top Port cannot be specified for Round or Square tops</p> <p>G1</p> <p>G1</p>	<p>See page 764</p> <p>D</p> <p>N</p>

PRESIDE® Laminate Tables — Bases

GSA SIN 33721



Icon Legend on page 19

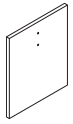

DESCRIPTION	PANELS INCLUDED PER KIT	MODEL	SHIP WEIGHT	CUBE	LIST PRICE BY LAMINATE GRADE	
					L1	L2
Laminate Panel Base for Tops 60" or Wider						
For 240"W Table Tops	4	HTLP240	197	16.4	\$1391	\$1471
For 216"W Table Tops	3	HTLP216	158	12.4	\$1065	\$1122
For 192"W Table Tops	3	HTLP192	147	11.6	\$1065	\$1122
For 180"W Table Tops	3	HTLP180	147	11.6	\$1065	\$1122
For 168"W Table Tops	3	HTLP168	136	10.6	\$928	\$983
For 144"W Table Tops	2	HTLP144	97	6.6	\$602	\$634
For 120"W Table Tops	2	HTLP120	86	5.8	\$602	\$634
For 108"W Table Tops	2	HTLP108	86	5.8	\$602	\$634
For 96"W Table Tops	2	HTLP96	75	4.9	\$602	\$634
For 84"W Table Tops	2	HTLP84	75	5.0	\$602	\$634
For 72"W Table Tops	2	HTLP72	25	2.9	\$567	\$599
For 60"W Table Tops	2	HTLP60	25	2.9	\$567	\$599
For 72" Adder Section	1	HTLPM	61	5.8	\$463	\$488

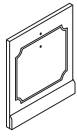

Laminate Traditional Panel Base for Tops 72" or Wider						
For 168"W Table Tops	3	HTLT168	145	12.1	\$1158	N/A
For 144"W Table Tops	2	HTLT144	106	8.2	\$832	N/A
For 120"W Table Tops	2	HTLT120	95	7.3	\$832	N/A
For 96"W Table Tops	2	HTLT96	62	4.6	\$832	N/A
For 72"W Table Tops	2	HTLT72	84	6.5	\$763	N/A

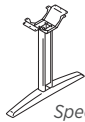

Specify paint

Aluminum T-Leg for Tops 60" or Wider						
For 240"W Table Tops	4	HTTLEG240	76	8.9	\$1906	N/A
For 216"W Table Tops	3	HTTLEG216	65	8.6	\$1521	N/A
For 192"W Table Tops	3	HTTLEG192	63	8.4	\$1454	N/A
For 180"W Table Tops	3	HTTLEG180	63	8.4	\$1454	N/A
For 168"W Table Tops	3	HTTLEG168	54	8.2	\$1362	N/A
For 144"W Table Tops	2	HTTLEG144	39	4.5	\$954	N/A
For 120"W Table Tops	2	HTTLEG120	37	4.3	\$887	N/A
For 108"W Table Tops	2	HTTLEG108	37	4.2	\$887	N/A
For 96"W Table Tops	2	HTTLEG96	31	4.0	\$820	N/A
For 84"W Table Tops	2	HTTLEG84	31	4.0	\$820	N/A
For 72"W Table Tops	2	HTTLEG72	26	3.5	\$631	N/A
For 60"W Table Tops	2	HTTLEG60	22	3.5	\$631	N/A
For 72" Adder Section	1	HTTLEGM	26	4.2	\$567	N/A

NOTES:

- Tops and bases are sold and shipped separately.
- All bases allow table tops to sit 29½" above floor with leveling glides half-way seated.
- Bases ship with appropriate number of supports for table width. See page 770 for details.
- Laminate panel bases feature sturdy 1½" thick x 12"H particleboard support beam in matching finish.
- Traditional panel base for 168"W Top includes two traditional panels and one standard panel.
- For Base and Top compatibility, see base information on pages 767-770.
- Aluminum T-legs for tops 96"W and greater feature dual aluminum support beams with integrated wire management. Aluminum T-legs for 60" and 72" tops do not include aluminum beams.
- Aluminum T-leg features a removable door for wire access.
- ! Traditional style bases available in Mahogany (N) only.

HOW TO SPECIFY

<p>Select Model Number</p> <p>HTLP240</p>	<p>Select Laminate</p> <p>See page 764</p> <p>D</p>
<p>Select Paint Color</p> <p>See page 764</p> <p>P Black PJW Designer White</p> <p>S Charcoal T4 Champagne (\$20 for bases with 1 or 2 supports, \$40 for bases with 3 or 4 supports)</p> <p> T1 Platinum (\$20 for bases with 1 or 2 supports, \$40 for bases with 3 or 4 supports)</p>	<p>T4</p>
<p>HTTLEG240</p>	



PRESIDE® Laminate Tables — Bases

TABLES

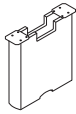

DESCRIPTION	PANELS INCLUDED PER KIT	MODEL	SHIP WEIGHT	CUBE	LIST PRICE BY LAMINATE GRADE	
					L1	L2
Laminate Hollow Panel Base for Tops 84" or Wider						
For 240"W Table Tops	3	HTLHP240	206	17.5	\$3047	\$3167
For 216"W Table Tops	3	HTLHP216	204	17.3	\$2966	\$3086
For 192"W Table Tops	3	HTLHP192	202	17.1	\$2899	\$3019
For 180"W Table Tops	3	HTLHP180	202	17.1	\$2899	\$3019
For 168"W Table Tops	3	HTLHP168	193	16.9	\$2807	\$2927
For 144"W Table Tops	2	HTLHP144	133	11.4	\$1925	\$2005
For 120"W Table Tops	2	HTLHP120	131	11.2	\$1858	\$1938
For 108"W Table Tops	2	HTLHP108	131	11.2	\$1858	\$1938
For 96"W Table Tops	2	HTLHP96	125	11.0	\$1791	\$1871
For 84"W Table Tops	2	HTLHP84	125	11.0	\$1791	\$1871
For 72" Adder Section	1	HTLHPM	71	5.9	\$1041	\$1081

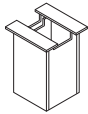

Laminate Cube Base for Tops 84" or Wider						
For 240"W Table Tops	3	HTLCUBE240	278	29.2	\$3647	\$3782
For 216"W Table Tops	3	HTLCUBE216	276	29.0	\$3566	\$3701
For 192"W Table Tops	3	HTLCUBE192	274	28.8	\$3499	\$3634
For 180"W Table Tops	3	HTLCUBE180	274	28.8	\$3499	\$3634
For 168"W Table Tops	2	HTLCUBE168	183	19.4	\$2406	\$2496
For 144"W Table Tops	2	HTLCUBE144	181	19.2	\$2325	\$2415
For 120"W Table Tops	2	HTLCUBE120	179	19.0	\$2258	\$2348
For 108"W Table Tops	2	HTLCUBE108	179	19.0	\$2258	\$2348
For 96"W Table Tops	2	HTLCUBE96	164	18.2	\$2002	\$2092
For 84"W Table Tops	2	HTLCUBE84	164	18.2	\$2002	\$2092
For 72" Adder Section	1	HTLCUBEM	95	9.8	\$1241	\$1286

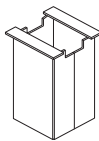

Laminate Standing-Height Cube Base for Tops 48" or Wider						
For 240"W Table Tops	3	HTLCUBES240	302	45.7	\$4409	\$4574
For 216"W Table Tops	3	HTLCUBES216	300	45.5	\$4328	\$4493
For 192"W Table Tops	3	HTLCUBES192	298	45.3	\$4261	\$4426
For 180"W Table Tops	3	HTLCUBES180	298	45.3	\$4261	\$4426
For 168"W Table Tops	2	HTLCUBES168	199	30.4	\$2914	\$3024
For 144"W Table Tops	2	HTLCUBES144	197	30.2	\$2833	\$2943
For 120"W Table Tops	2	HTLCUBES120	195	30.0	\$2766	\$2876
For 108"W Table Tops	2	HTLCUBES108	195	30.0	\$2766	\$2876
For 96"W Table Tops	2	HTLCUBES96	180	29.2	\$2510	\$2620
For 72" Adder	1	HTLCUBESM	103	15.3	\$1495	\$1550

NOTES:

- Tops and bases are sold and shipped separately.
 - Bases ship with appropriate number of supports for table width. See page 770 for details.
 - Standing-height Cube Bases are 39"H.
 - For Base and Top compatibility, see base information on pages 767-770.
 - Laminate cube bases for tops 120"W and greater feature dual aluminum support beams with integrated wire management.
 - End caps for Hollow Panel bases can be matched to woodgrain finishes or specified in select solid colors.
 - Cube bases feature removable door to allow access to cables and enable wire routing.
 - Standing-Height Bases feature a hinged door for easy access and for cable routing through the base.
- ⚠ Seated Cube Base requires 150 lbs. of sand or other ballast in each base for stability (not supplied). Standing-height Cube Base does not require additional ballast.

HOW TO SPECIFY

<p>Select Model Number</p> <p>HTLHP240</p>	<p>Select Laminate</p> <p>See page 764</p> <p>D</p>	<p>Select Endcap/Inlay Option</p> <p>(specified for Hollow Panel Bases only)</p> <table border="0"> <tr> <td>L1</td> <td>L2</td> </tr> <tr> <td>H Bourbon Cherry</td> <td>P Black</td> </tr> <tr> <td>COGN Cognac</td> <td>S Charcoal</td> </tr> <tr> <td>LFW1 Florence Walnut</td> <td>LDW1 Designer White</td> </tr> <tr> <td>C Harvest</td> <td>LOFT Loft</td> </tr> <tr> <td>LK11 Kingswood Walnut</td> <td>LEP1 Platinum</td> </tr> <tr> <td>N Mahogany</td> <td></td> </tr> <tr> <td>MOCH Mocha</td> <td></td> </tr> <tr> <td>D Natural Maple</td> <td></td> </tr> <tr> <td>PINC Pinnacle</td> <td></td> </tr> <tr> <td>F Shaker Cherry</td> <td></td> </tr> <tr> <td>LSA1 Sterling Ash</td> <td></td> </tr> </table> <p>H</p>	L1	L2	H Bourbon Cherry	P Black	COGN Cognac	S Charcoal	LFW1 Florence Walnut	LDW1 Designer White	C Harvest	LOFT Loft	LK11 Kingswood Walnut	LEP1 Platinum	N Mahogany		MOCH Mocha		D Natural Maple		PINC Pinnacle		F Shaker Cherry		LSA1 Sterling Ash	
L1	L2																									
H Bourbon Cherry	P Black																									
COGN Cognac	S Charcoal																									
LFW1 Florence Walnut	LDW1 Designer White																									
C Harvest	LOFT Loft																									
LK11 Kingswood Walnut	LEP1 Platinum																									
N Mahogany																										
MOCH Mocha																										
D Natural Maple																										
PINC Pinnacle																										
F Shaker Cherry																										
LSA1 Sterling Ash																										

PRESIDE® Laminate Tables — Bases

GSA SIN 33721



Icon Legend on page 19

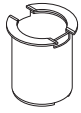

DESCRIPTION	PANELS INCLUDED PER KIT	MODEL	SHIP WEIGHT	CUBE	LIST PRICE BY LAMINATE GRADE	
					L1	L2
Laminate Cylinder Base for Tops 84" or Wider						
For 240"W Table Tops	3	HTLR240	191	51.9	\$2954	\$3059
For 216"W Table Tops	3	HTLR216	189	51.7	\$2873	\$2978
For 192"W Table Tops	3	HTLR192	187	51.5	\$2806	\$2911
For 180"W Table Tops	3	HTLR180	187	51.5	\$2806	\$2911
For 168"W Table Tops	2	HTLR168	125	34.5	\$1944	\$2014
For 144"W Table Tops	2	HTLR144	123	34.3	\$1863	\$1933
For 120"W Table Tops	2	HTLR120	121	34.1	\$1796	\$1866
For 108"W Table Tops	2	HTLR108	121	34.1	\$1796	\$1866
For 96"W Table Tops	2	HTLR96	106	33.3	\$1540	\$1610
For 84"W Table Tops	2	HTLR84	106	33.3	\$1540	\$1610
For 72" Adder Section	1	HTLRM	66	17.4	\$1010	\$1045



Laminate Cylinder Base with Wire Management for Tops 84" or Wider						
For 240"W Table Tops	3	HTLRC240	191	51.9	\$3842	\$3977
For 216"W Table Tops	3	HTLRC216	189	51.7	\$3761	\$3896
For 192"W Table Tops	3	HTLRC192	187	51.4	\$3694	\$3829
For 180"W Table Tops	3	HTLRC180	187	51.4	\$3694	\$3829
For 168"W Table Tops	2	HTLRC168	125	34.5	\$2536	\$2626
For 144"W Table Tops	2	HTLRC144	123	34.3	\$2455	\$2545
For 120"W Table Tops	2	HTLRC120	121	34.1	\$2388	\$2478
For 108"W Table Tops	2	HTLRC108	121	34.1	\$2388	\$2478
For 96"W Table Tops	2	HTLRC96	106	33.3	\$2132	\$2222
For 84"W Table Tops	2	HTLRC84	106	33.3	\$2132	\$2222
For 72" Adder	1	HTLRM	66	17.4	\$1306	\$1351

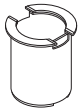
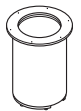

Used with 36" and 42" table tops

Laminate Cylinder Base for Round and Square Tops						
For 48" Tops	1	HTLR48	53	16.7	\$770	\$805
For 42" Tops	1	HTLR42	42	11.6	\$695	\$730
For 36" Tops	1	HTLR36	42	11.6	\$695	\$730
For 48" Tops, with Wire Management	1	HTLRC48	53	16.7	\$1066	\$1111

NOTES:

- Tops and bases are sold and shipped separately.
 - Bases ship with appropriate number of supports for table width. See page 770 for details.
 - For Base and Top compatibility, see base information on pages 767-770.
 - Cylinder base requires 150 pounds of sand or other ballast in each base for stability (customer to supply).
 - Cylinder bases facilitate wire management with integrated wire channel and plinth.
 - Laminate cylinder bases for tops 120"W and greater feature dual aluminum support beams with integrated wire management.
 - Laminate Cylinder Bases with Wire Management include a unique design that allows cords to be routed through the base with easy access to electrical outlets.
- ! Cylinder Base requires 150 lbs. of sand or other ballast in each base for stability (not supplied).

HOW TO SPECIFY

Select Model Number	Select Laminate
HTLR240	See page 764
D	



PRESIDE® Laminate Tables — Bases

	DESCRIPTION	BASES INCLUDED PER KIT	MODEL	SHIP WEIGHT	CUBE	LIST PRICE BY LAMINATE GRADE	
						L1	L2
	Laminate Cube Base for Round and Square Tops						
	For 48" Tops, Seated Height	1	HTLCUBE48	82	9.1	\$1001	\$1046
	For 48" Tops, Standing-Height	1	HTLCUBES48	90	14.6	\$1255	\$1310
	Laminate Panel X-Base for Round and Square Tops						
	For 48" Tops	1	HTLXP48	54	5.2	\$446	\$466
	For 42" Tops	1	HTLXP42	54	5.2	\$446	\$466
	For 36" Tops	1	HTLXP36	47	4.7	\$415	\$435
	Traditional X-Base for Round and Square Tops						
	Can be used with 36", 42" and 48" Round Tops and 36" and 42" Square Tops. Not compatible with cutouts or power ports.	1	H94011	40	5.4	\$822	N/A

NOTES: Available in Mahogany (N) Veneer only.

! Must be ordered with a configurable end product. If ordered separately, not on GSA Contract.

	DESCRIPTION	BASES INCLUDED PER KIT	MODEL	SHIP WEIGHT	CUBE	LIST PRICE	P2 LIST PRICE
						\$501	\$525
	Aluminum X-Leg Base for Round and Square Tops	1	HTXLEG	16	3.5	\$501	\$525
	<i>Specify paint</i>						
	Standing-Height Aluminum X-Leg Base for 36" and 42" Round and Square Tops	1	HTXLEGSH	17	3.5	\$625	\$645
	<i>Specify paint</i>						

NOTES:

- Tops and bases are sold and shipped separately.
 - For Base and Top compatibility, see base information on pages 767-770.
 - All bases allow table tops to sit 29½" above floor with leveling glides half-way retracted.
 - Cube base features removable door for wire management.
 - The X-leg allows wires to pass through the center of the leg.
- !** Cube Base requires 150 lbs. of sand or other ballast in each base for stability (not supplied).

HOW TO SPECIFY

Select Model Number

HTLCUBE48

HTXLEG

Select Laminate

See page 764

D

Select Paint Color

See page 764

P Black PJW Designer White
S Charcoal T4 Champagne
 T1 Platinum

T4

PRESIDE® Collaborative Tables

GSA SIN 33721



Icon Legend on page 19

TABLES

	DESCRIPTION	MODEL	SHIP WEIGHT	CUBE	LIST PRICE BY LAMINATE GRADE	
					L1	L2
	Seated Height, Collaborative Table with Partial Modesty Panel					
	72"W x 42"D 96"W x 42"D	HTLC4272LCTP HTLC4296LCTP	167 122	14.5 18.3	\$1383 \$1703	\$1413 \$1733
	Café-Height, Collaborative Table with Partial Modesty Panel					
	72"W x 42"D 96"W x 42"D	HTLC4272HCTP HTLC4296HCTP	187 242	15.7 19.4	\$1549 \$1869	\$1579 \$1899
	Seated Height, Collaborative Table with Full Modesty Panel					
	72"W x 42"D 96"W x 42"D	HTLC4272LCTFP HTLC4296LCTFP	175 233	14.9 18.8	\$1383 \$1703	\$1413 \$1733
	Café-Height, Collaborative Table with Full Modesty Panel					
	72"W x 42"D 96"W x 42"D	HTLC4272HCTFP HTLC4296HCTFP	211 275	17.9 22.4	\$1549 \$1869	\$1579 \$1899
	Seated Height, Collaborative Table with Power Management					
	72"W x 42"D 96"W x 42"D	HTLC4272LCTHP HTLC4296LCTHP	196 244	13.6 16.0	\$1661 \$1981	\$1691 \$2011
NOTES: Wire management available underneath top and through the base. Bases include a removable door to access cords at any time.						
	Café-Height, Collaborative Table with Power Management					
	72"W x 42"D 96"W x 42"D	HTLC4272HCTHP HTLC4296HCTHP	236 284	15.8 18.3	\$1991 \$2311	\$2021 \$2341
NOTES: Wire management available underneath top and through the base. Bases include a removable door to access cords at any time.						

NOTES:

- Tops feature 2MM flat edge.

! Tables with partial and full modesty panels can support grommet inserts. However, wire management is not available in the legs.

HOW TO SPECIFY



Select Model Number	Select Cutout Option	Select Top Laminate Color	Select Base Laminate Color	Select Modesty Laminate Color	Select 2MM Edge Color
	N No Cutout G1 Cutout for Pop-up Port (\$40 upcharge) G2 Cutout for Flip-top Port (\$50 upcharge)	See page 764 L2 Upcharge \$30	See page 764 L2 Upcharge \$30	See page 764 <i>Do not specify for models HTLC4272LCTHP, HTLC4296LCTHP, HTLC4272HCTHP, and HTLC4296HCTHP</i> L2 Upcharge \$30	See page 765
HTLC4272LCTP	N	H	H	LDW1	H

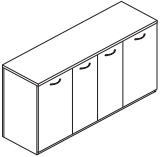

Icon Legend on page 19

PRESIDE® Laminate Storage

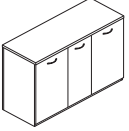
	DESCRIPTION	MODEL	SHIP WEIGHT	CUBE	LIST PRICE BY LAMINATE GRADE	
					L1	L2
	72" Laminate Hospitality Credenza • Overall cabinet dimensions 72"W x 20"D x 36"H. • Features two hidden drawers, one in each center cabinet. ⓘ Features 2 ventilation cutouts in back. 1 in each end cabinet.	HTLCREDA	301	37.0	\$2852	\$2977

 	57" Laminate Hospitality Credenza • Features one hidden drawer in center cabinet. ⓘ Features 2 ventilation cutouts in back. 1 in each end cabinet.	HTLCREDB	250	29.3	\$2480	\$2580
--	---	-----------------	-----	------	--------	--------

NOTES:

- Can support mini refrigerators with maximum measurements of 19"W x 19"D x 32"H.
- Each end cabinet can accommodate an optional trash bin, AV rack, or shelf accessory.

HOW TO SPECIFY

Select Model Number HTLCREDA.	Select Edge Detail and Color G Flat Edge GD.	Select Top Laminate See page 764 HTLCREDA L2 Upcharge: \$50 HTLCREDB L2 Upcharge: \$40 D.	Select Chassis Laminate See page 764 HTLCREDA L2 Upcharge: \$75 HTLCREDB L2 Upcharge: \$60 D.	Select Handle J Loop Satin Nickel G Loop Black 3 Rounded Square Matte Chrome 4 Rounded Square Black J
---	---	--	--	---

	DESCRIPTION	MODEL	SHIP WEIGHT	CUBE	L1	L2
					LIST PRICE	UPCHARGE
	Trash Bin Slide • Holds a 35 quart bin. • Trash bin is included with model. • Can be used in outer compartments of HTLCREDA and HTLCREDB.	HTBINSLIDE	15	3.5	\$210	N/A

OPEN MARKET

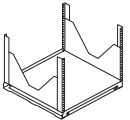
	Mounted AV Rack • Can be used in outer compartments of HTLCREDA and HTLCREDB.	HTRACK	15	4.8	\$1916	N/A
---	---	---------------	----	-----	--------	-----

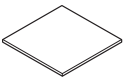
	Laminate Credenza Shelf • Shelf can be utilized in the outer compartments of the credenza. • 3 mounting locations within outer compartment on the credenza. • Mounting locations are 6" apart.	HTLSHELF	10 ⓘ	1.5	\$71	\$10
---	--	-----------------	------	-----	------	------

HOW TO SPECIFY

Select Model Number HTBINSLIDE.	Select Laminate See page 764 H.	Select Handle J Loop Satin Nickel G Loop Black G
---	--	--

PRESIDE® Laminate Storage

GSA SIN 33721



Icon Legend on page 19

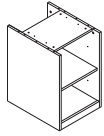

Model HTLMC18280 shown



DESCRIPTION	MODEL	SHIP WEIGHT	CUBE	LIST PRICE BY LAMINATE GRADE	
				L1	L2
Modular Pedestal, Bookshelf, No Door	HTLMC18280	70	9.8	\$554	\$579

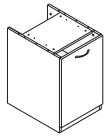

Model HTLMC1828L shown



Modular Pedestal, Bookshelf, with Door (left)	HTLMC1828L	70	9.8	\$675	\$705
Modular Pedestal, Bookshelf, with Door (right)	HTLMC1828R	70	9.8	\$675	\$705

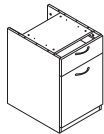

Model HTLMC1828DR shown



Modular Pedestal, Box Drawer, Cabinet Door (left)	HTLMC1828DL	70	9.8	\$718	\$748
Modular Pedestal, Box Drawer, Cabinet Door (right)	HTLMC1828DR	70	9.8	\$718	\$748

TABLES

NOTES:

- Use Concinnity™ laminate tops and backs with Preside® modular storage for a finished look. See page 783.

HOW TO SPECIFY

<p>Select Model Number</p> <p>HTLMC1828L</p>	<p>Select Pull Option</p> <ul style="list-style-type: none"> J Loop Satin Handle G Loop Back 3 Rounded Square Matte Chrome 4 Rounded Square Black X No Pull (for model HTLMC18280 only) <p>J</p>	<p>Select Laminate</p> <p>See page 764</p> <p>N</p>
---	--	--

DESCRIPTION	MODEL	SHIP WEIGHT	CUBE	LIST PRICE BY LAMINATE GRADE	
				L1	L2
<p>Laminate Lectern</p> <ul style="list-style-type: none"> • Overall cabinet dimensions 24"W x 18"D x 50"H. • Adjustable top worksurface features 3 tilt positions. • Top of lectern can be removed and used on table top. • Laptop shelf slides left or right. • Includes 2 locking and 2 non-locking casters. • Includes adjustable shelf in storage compartment. • Features scallops in rear of lectern to route and conceal cables and wires. • Metal components standard in black finish. 	HTLLECTA	132	15.6	\$1518	\$1583

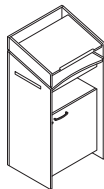

HOW TO SPECIFY

<p>Select Model Number</p> <p>HTLLECTA</p>	<p>Select Laminate</p> <p>See page 764</p> <p>H</p>	<p>Select Handle</p> <ul style="list-style-type: none"> J Loop Satin Nickel G Loop Black <p>G</p>
---	--	--



MODULAR COMPONENTS

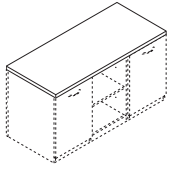

DESCRIPTION	MODEL	SHIP WEIGHT	CUBE	LIST PRICE BY LAMINATE GRADE	
				L1	L2
Concinnity™ Rectangle Worksurface with Horizontal Grain					
90"W x 24"D	HNLRC2490	75	5.5	\$522	\$552
72"W x 24"D	HNLRC2472	60	4.6	\$366	\$386
54"W x 24"D	HNLRC2454	45	3.5	\$299	\$319
36"W x 24"D Rectangle Worksurface/Pedestal Top	HNLRC2436	30	2.4	\$230	\$245

NOTES: Use Concinnity™ laminate tops and backs with Preside® modular storage for a finished look.

- ! Grain direction on all rectangle worksurfaces runs horizontal (side-to-side) except as follows: 30"W - 36"W - 42"W - 48"W - 54"W - 60"W x 24"D tops can be specified with horizontal (side-to-side) or vertical (front-to-back) grain.
- ! 42"W and 48"W x 20"D tops are available with vertical (front-to-back) grain only.

HOW TO SPECIFY

<p>Select Model Number</p> <p>H N L R C 2 4 9 0 .</p>	<p>Select Edge Profile and Edge Color</p> <p>See page 29</p> <p>B H .</p>	<p>Select Worksurface Grommet Finish</p> <p>P Black T1 Platinum X No Grommet</p> <p>P .</p>	<p>Select Worksurface Color</p> <p>See page 29</p> <p>H</p>
--	--	--	--

TABLES



MODULAR COMPONENTS

Back Panels

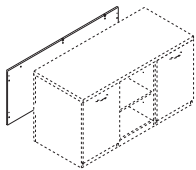

DESCRIPTION	MODEL	SHIP WEIGHT	CUBE	LIST PRICE BY LAMINATE GRADE	
				L1	L2
Concinnity™ Modesty/Back Panels — Full-Length					
90"W x 27 ⁷ / ₈ "H	HNLMP9028	58	6.7	\$419	\$444
72"W x 27 ⁷ / ₈ "H	HNLMP7228	46	5.3	\$285	\$305
54"W x 27 ⁷ / ₈ "H	HNLMP5428	34	4.0	\$235	\$255
36"W x 27 ⁷ / ₈ "H Modesty/Pedestal Back Panel	HNLMP3628	22	2.8	\$188	\$200

NOTES: Component is 3/4" thick. Provide approach-side kneespace privacy for user seated at desks, credenzas, returns, and bridges.

HOW TO SPECIFY

<p>Select Model Number</p> <p>H N L M P 7 2 2 8 .</p>	<p>Select Grommet</p> <p>P Black X No Grommet</p> <p>X .</p>	<p>Select Laminate Color</p> <p>See page 29</p> <p>H</p>
--	---	---

WALL MOUNT STORAGE

OPEN MARKET



Icon Legend on page 19

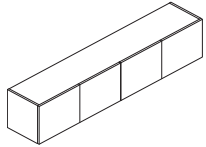

DESCRIPTION

Concinnity™ Wall Mount Storage, Laminate Doors

- 78"W x 15"D x 15"H — 4 doors, 2 compartments
- 72"W x 15"D x 15"H — 4 doors, 2 compartments
- 66"W x 15"D x 15"H — 4 doors, 2 compartments
- 60"W x 15"D x 15"H — 4 doors, 2 compartments
- 48"W x 15"D x 15"H — 3 doors, 2 compartments
- 42"W x 15"D x 15"H — 2 doors, 1 compartment
- 36"W x 15"D x 15"H — 2 doors, 1 compartment
- 30"W x 15"D x 15"H — 2 doors, 1 compartment

MODEL	SHIP WEIGHT	CUBE	L1 LIST	L2 UPCHARGES	
				CHASSIS	FRONTS
HNL1578LD	126	17.1	\$1245	\$35	\$20
HNL1572LD	118	15.9	\$1156	\$25	\$20
HNL1566LD	109	14.6	\$1101	\$25	\$20
HNL1560LD	100	13.3	\$989	\$25	\$20
HNL1548LD	83	10.9	\$892	\$20	\$20
HNL1542LD	68	9.7	\$842	\$20	\$10
HNL1536LD	60	8.4	\$770	\$20	\$10
HNL1530LD	51	7.2	\$711	\$20	\$10

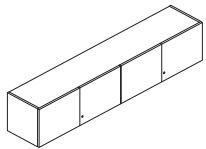

Concinnity™ Wall Mount Storage, Laminate Locking Doors

- 78"W x 15"D x 15"H — 4 doors, 2 compartments
- 72"W x 15"D x 15"H — 4 doors, 2 compartments
- 66"W x 15"D x 15"H — 4 doors, 2 compartments
- 60"W x 15"D x 15"H — 4 doors, 2 compartments
- 48"W x 15"D x 15"H — 3 doors, 2 compartments
- 42"W x 15"D x 15"H — 2 doors, 1 compartment
- 36"W x 15"D x 15"H — 2 doors, 1 compartment
- 30"W x 15"D x 15"H — 2 doors, 1 compartment

HNL1578LL	126	17.1	\$1327	\$35	\$20
HNL1572LL	118	15.9	\$1238	\$25	\$20
HNL1566LL	109	14.6	\$1184	\$25	\$20
HNL1560LL	100	13.3	\$1071	\$25	\$20
HNL1548LL	83	10.9	\$933	\$20	\$20
HNL1542LL	68	9.7	\$883	\$20	\$10
HNL1536LL	60	8.4	\$811	\$20	\$10
HNL1530LL	51	7.2	\$752	\$20	\$10

! Lock available in Black (P) or Satin (SA) finish. Lock is core removable. Keyed alike cores must be ordered separately. For stack-on and wall mount storage with locking hinged doors, specify model HF27B (Black) or HF27S (Satin) and the key number, see page 112. Model HNL1548LL has one lock, which secures two of the three doors.

NOTES:

- Preside® tables pair well with Concinnity™ Wall Mounted Storage to create a complete conference or collaborative layout.
- Convenient off-the-worksurface storage requires no additional floor space.
- Available with laminate doors, frosted/silver doors, or sliding door.
- Doors are sized to overlap the top, end panels and light valance, to provide a clean design.
- Laminate and frosted/silver door units are equipped with self-closing, adjustable hinges.
- Laminate hinged door units are available with or without a lock.
- For , see page 65.
- For task lights, see page 113.
- For paper organizers, see page 110.
- **IMPORTANT: See installation guidelines at top of page 60.**

HOW TO SPECIFY

Select Model Number H N L 1 5 7 8 L D	Select Chassis Color See page 29 H	Select Door Front Color See page 29 H	
Select Model Number H N L 1 5 7 8 L L	Select Lock Finish See page 29 P	Select Chassis Color See page 29 H	Select Door Front Color See page 29 H



WALL MOUNT STORAGE

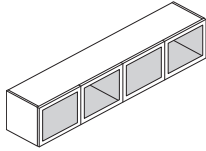

DESCRIPTION

Concinnity™ Wall Mount Storage, Frosted Doors with Silver Frame

- 78"W x 15"D x 15"H — 4 doors, 2 compartments
- 72"W x 15"D x 15"H — 4 doors, 2 compartments
- 66"W x 15"D x 15"H — 4 doors, 2 compartments
- 60"W x 15"D x 15"H — 4 doors, 2 compartments
- 48"W x 15"D x 15"H — 3 doors, 2 compartments
- 42"W x 15"D x 15"H — 2 doors, 1 compartment
- 36"W x 15"D x 15"H — 2 doors, 1 compartment
- 30"W x 15"D x 15"H — 2 doors, 1 compartment

MODEL	SHIP WEIGHT	CUBE	L1 LIST	L2 UPCHARGES	
				CHASSIS	FRONTS
HNL1578FD	106	17.1	\$1864	\$35	N/A
HNL1572FD	99	15.9	\$1775	\$25	N/A
HNL1566FD	92	14.6	\$1721	\$25	N/A
HNL1560FD	85	13.3	\$1608	\$25	N/A
HNL1548FD	71	10.9	\$1356	\$20	N/A
HNL1542FD	57	9.7	\$1152	\$20	N/A
HNL1536FD	50	8.4	\$1079	\$20	N/A
HNL1530FD	43	7.2	\$1021	\$20	N/A

❗ Frosted door models do not have a lock option.

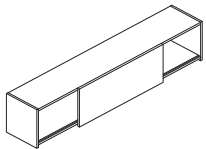

Concinnity™ Wall Mount Storage, Sliding Door

- 78"W x 15"D x 15"H
- 72"W x 15"D x 15"H
- 66"W x 15"D x 15"H
- 60"W x 15"D x 15"H
- 48"W x 15"D x 15"H

HNL1578SD	114	17.1	\$1212	\$35	\$20
HNL1572SD	107	15.9	\$1113	\$25	\$20
HNL1566SD	99	14.6	\$1036	\$25	\$20
HNL1560SD	91	13.3	\$941	\$25	\$20
HNL1548SD	76	10.9	\$881	\$20	\$20

NOTES: One door per unit. Standard with black lock, which is located on the inside vertical support panel.

NOTES:

- Preside® tables pair well with Concinnity™ Wall Mounted Storage to create a complete conference or collaborative layout.
- Convenient off-the-worksurface storage requires no additional floor space.
- Available with laminate doors, frosted/silver doors, or sliding door.
- Doors are sized to overlap the top, end panels and light valance, to provide a clean design.
- Laminate and frosted/silver door units are equipped with self-closing, adjustable hinges.
- Laminate hinged door units are available with or without a lock.
- For , see page 65.
- For task lights, see page 113.
- For paper organizers, see page 110.
- **IMPORTANT: See installation guidelines at top of page 60.**

HOW TO SPECIFY

<p>Select Model Number</p> <div style="border: 1px solid black; display: flex; justify-content: space-between; padding: 2px;"> HNL1578FD </div>	<p>Select Chassis Color</p> <p>See page 29</p> <div style="border: 1px solid black; display: flex; justify-content: space-between; padding: 2px;"> H </div>	
<p>Select Model Number</p> <div style="border: 1px solid black; display: flex; justify-content: space-between; padding: 2px;"> HNL1578SD </div>	<p>Select Chassis Color</p> <p>See page 29</p> <div style="border: 1px solid black; display: flex; justify-content: space-between; padding: 2px;"> H </div>	<p>Select Door Front Color</p> <p>See page 29</p> <div style="border: 1px solid black; display: flex; justify-content: space-between; padding: 2px;"> H </div>

PRESIDE® Laminate Shared Components

GSA SIN 33721 EXCEPT AS NOTED



Icon Legend on page 19

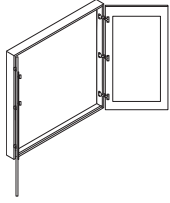

DESCRIPTION

Laminate Presentation Cabinet

- Overall cabinet dimensions 48½"W x 5"D x 49½"H.
- Mounts to wall.
- Presentation cabinet features one magnetic white board, one and one paper pad.
- Self-adjusting hinges ensure doors are in alignment.

MODEL	SHIP WEIGHT	CUBE	LIST PRICE BY LAMINATE GRADE	
			L1	L2
HTLPRES	169	10.9	\$1663	\$1743

HOW TO SPECIFY

TABLES

Select Model Number

Select Laminate

See page 764

H T L P R E S . D

DESCRIPTION

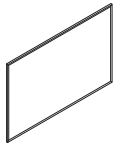

OPEN MARKET

- Overall dimensions 48"W x 31"H.
 - Mounts on wall. Can be mounted horizontally or vertically.
 - is magnetic.
 - No specification required.
- NOTES: For additional information see page 847.

MODEL	SHIP WEIGHT	CUBE	LIST PRICE
HLSL4831MB	44.0	3.4	\$664

Field Installable Drawer/Door Handle Kits

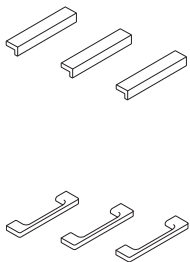

- Linear, Black, 1-pack
- Linear, Matte Chrome, 1-pack
- Linear, Black, 8-pack
- Linear, Matte Chrome, 8-pack
- Arch, Black, 1-pack
- Arch, Matte Chrome, 1-pack
- Arch, Black, 8-pack
- Arch, Matte Chrome, 8-pack

HLINEARA1	0.5	1.4	\$33
HLINEARC1	0.5	1.4	\$33
HLINEARA8	0.5	1.4	\$183
HLINEARC8	0.5	1.4	\$183
HARCHA1	0.5	1.4	\$33
HARCHC1	0.5	1.4	\$33
HARCHA8	0.5	1.4	\$183
HARCHC8	0.5	1.4	\$183

HOW TO SPECIFY

Select Model Number

H L I N E A R A 1

CABLE MANAGEMENT

Icon Legend on page 19

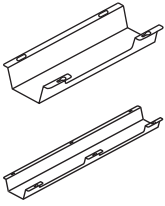

DESCRIPTION

Cable Management Troughs

- 17"W — Single
- 17"W — 10-Pack
- 36"W — Single
- 36"W — 10-Pack

- Cable management troughs ship flat packed.
- The troughs attach to underneath the worksurface with screws.
- Cutouts in trough allow access to power without the need to detach from surface. 17"W = 1 cutout; 36"W = 2 cutouts.
- Color: Graphite.
- Material: Metal.
- TAA Compliant.

NOTES: For additional information see page 852.

MODEL	SHIP WEIGHT	CUBE	LIST PRICE
HCTROUGH17	2.7	0.5	\$67
HCTROUGH1710	14.0	0.5	\$620
HCTROUGH36	4.9	0.9	\$113
HCTROUGH3610	30.0	0.9	\$1045

TABLES

HOW TO SPECIFY

Select Model Number

H C T R O U G H 1 7

PRESIDE® Table Power Accessories

GSA SIN 33721 EXCEPT AS NOTED



Icon Legend on page 19

TABLES

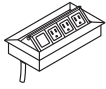

DESCRIPTION

Pop-up Port

- Fits into 4" x 8" cutout.
- Specify G1 cutout in table top.
- Pop-up Port provides three power ports and one blank data receptacle.
- Sits flush with worksurface when closed.
- Finish is anodized aluminum.
- Includes 6' cord with three-prong plug.

MODEL

HTPWRGROM1

SHIP WEIGHT

5.0

CUBE

0.3

LIST PRICE

\$392

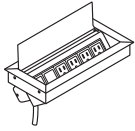

Flip-top Port

- Fits into 5" x 11" cutout.
- Specify G2 cutout in table top.
- Flip-top Port provides four power ports and two blank data receptacles.
- Conceals wires and allows power cords to be plugged in while in use.
- Includes 10' cord with three-prong circuit breaker plug.

HTPWRGROM2

5.0

0.3

\$579

NOTES: Two circuit breaker plugs do not fit into one duplex.

Flip-top Port

- Fits into 5" x 11" cutout.
- Specify G2 cutout in table top.
- Flip-top Port provides one blank Extron plate and three power ports.
- Extron AAP plates can be integrated into grommet to support changing technology.
- Conceals wires and allows power cords to be plugged in while in use.
- Includes 10' cord with three-prong circuit breaker plug.

HTPWRGROM4

5.0

0.3

\$710

Flip-top Port

- Fits into 5" x 11" cutout.
- Specify G2 cutout in table top.
- Flip-top Port provides 3 Power, 1 USB and 2 Blank Data Ports.
- Conceals wires and allows power cords to be plugged in while in use.
- Includes 10' cord with three-prong circuit breaker plug.

HTPWRGROM5

5.0

0.3

\$841

NOTES:

- For additional information see page 850.

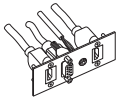

DESCRIPTION

Extron Plate (Double Space) — VGA, HDMI, HDMI, Audio

NOTES: For additional information see page 851.

MODEL

HTPLATEVHAU

SHIP WEIGHT

1

CUBE

0.1

LIST PRICE

\$399

OPEN MARKET



NOTES:

- ! Extron plates can be retrofitted to be used on HTPWRGROM4.



HOW TO SPECIFY

Select
Model Number

H T P W R G R O M 1

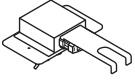
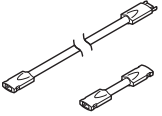

PRESIDE® Table Power Accessories

	DESCRIPTION	MODEL	SHIP WEIGHT	CUBE	LIST PRICE
Hardwire Power System:					
The hardwire power system is only needed if 6' power cables from power ports are not long enough to reach an outlet, or if there is a need to route power below entire length of worksurface from one power in-feed. By specifying one power kit for each top section, there will be two duplex receptacles below each top section. For technical details regarding 2-circuit power system, see page 744.					
	Power Entry Plate • Connects to wall to route power to table.	HMAPLATE	1.0	0.2	\$93
	Power Entry Cable • 6' power entry cable with male/female adapter. • Connects table to power entry plate.	HMACABLE	1.8	0.2	\$144
	Circuit 1 Power Kit for 60"W Top Section Circuit 1 Power Kit for 72"W Top Section Circuit 1 Power Kit for 84"W Top Section Circuit 1 Power Kit for 96"W Top Section	HMAPOWER60 HMAPOWER72 HMAPOWER84 HMAPOWER96	2.0 2.2 2.4 2.6	0.3 0.3 0.3 0.3	\$276 \$281 \$291 \$300

TABLES

HOW TO SPECIFY

Select
Model Number

H M A P L A T E

PRESIDE® Laminate Tables

GSA SIN 33721

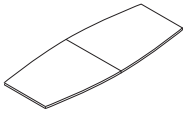
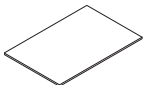
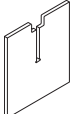

Icon Legend on page 19

	DESCRIPTION	MODEL	SHIP WEIGHT	CUBE	LIST PRICE								
	Laminate Boat Shaped Table Tops with Stretcher												
	168"W x 48"D	HTLB16848P	319	11.9	\$1463								
	144"W x 48"D	HTLB14448P	266	9.8	\$1162								
	120"W x 48"D	HTLB12048P	217	8.2	\$1053								
	Laminate Adder Section with Stretcher 72"W x 48"D	HTLM7248P	144	9.8	\$772								
	Laminate Bases												
	Laminate Panel Bases, Double Pack Laminate Panel Bases, Single Pack	HTLPB HTLPBS	53 28	3.1 3.1	\$417 \$252								
			<table border="1"> <thead> <tr> <th></th> <th>With Panel Base</th> </tr> </thead> <tbody> <tr> <td>HTLB12048P HTLB14448P</td> <td>1 x HTLPB (Laminate Panel Base)</td> </tr> <tr> <td>HTLB16848P</td> <td>1 x HTLPB (Laminate Panel Base) 1 x HTLPBS (Laminate Panel Mid-Base)</td> </tr> <tr> <td>HTLM7248P</td> <td>1 x HTLPBS (Laminate Panel Mid-Base)</td> </tr> </tbody> </table>				With Panel Base	HTLB12048P HTLB14448P	1 x HTLPB (Laminate Panel Base)	HTLB16848P	1 x HTLPB (Laminate Panel Base) 1 x HTLPBS (Laminate Panel Mid-Base)	HTLM7248P	1 x HTLPBS (Laminate Panel Mid-Base)
	With Panel Base												
HTLB12048P HTLB14448P	1 x HTLPB (Laminate Panel Base)												
HTLB16848P	1 x HTLPB (Laminate Panel Base) 1 x HTLPBS (Laminate Panel Mid-Base)												
HTLM7248P	1 x HTLPBS (Laminate Panel Mid-Base)												

TABLES

NOTES:

- Tops and Modesty Panels are 1/8" Melamine.
- 168"W Boat-Shaped Top needs 3 bases; 72"W Middle Adder needs 1 base. All other tops need 2 bases.
- 120", 144", and 168"W Tops ship in 2 pieces to facilitate handling and installation; these top sizes will not have an exact grain alignment where the two halves meet, a reasonable match can be expected.
- ! Tops with Stretcher and Adder Section with Stretcher available in Harvest (C) and Mahogany (N) finishes only.
- ! Tops available in Boat Shape with G edge (2mm self edge) only; Middle Adder is rectangular with G edge.
- ! Edge finish always matches top finish.

HOW TO SPECIFY

<p>Select Model Number</p> <p>H T L B 1 6 8 4 8 P .</p>	<p>Select Grommet Option</p> <p>N No grommet (only option)</p> <p>N .</p>	<p>Select Laminate</p> <p>C Harvest N Mahogany</p> <p>C</p>
--	--	--



Laminate Tables — Pre-defined Typicals

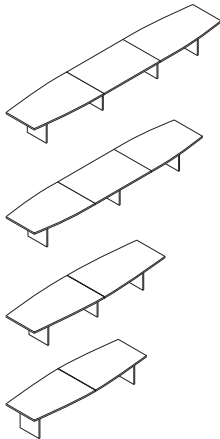

DESCRIPTION

Boat Shape Laminate Tables with Panel Base

- 240"W x 48"D
- 216"W x 48"D
- 192"W x 48"D
- 168"W x 48"D
- 144"W x 48"D
- 120"W x 48"D

MODEL

- HTLB2048LP**
- HTLB1848LP**
- HTLB1648LP**
- HTLB1448LP**
- HTLB1248LP**
- HTLB1048LP**

SHIP WEIGHT

- 572
- 491
- 442
- 400
- 319
- 270

CUBE

- 31.0
- 25.9
- 24.3
- 18.1
- 12.9
- 11.3

LIST PRICE

- \$3156**
- \$2603**
- \$2494**
- \$2132**
- \$1579**
- \$1470**

NOTES: Order entire typical with one model number to get desired table size. Table top and bases are included.

NOTES:

- Tops and Modesty Panels are 1/4" Melamine.
- 168"W Boat-Shaped Top needs 3 bases; 72"W Middle Adder needs 1 base. All other tops need 2 bases.
- 120", 144", and 168"W Tops ship in 2 pieces to facilitate handling and installation; these top sizes will not have an exact grain alignment where the two halves meet, a reasonable match can be expected.
- ! Available in Harvest (C) and Mahogany (N) finishes only.
- ! Tops available in Boat Shape with G edge (2mm self edge) only; Middle Adder is rectangular with G edge.
- ! Edge finish always matches top finish.

TABLES

HOW TO SPECIFY

<p>Select Model Number</p> <p>HTLB2048LP .</p>	<p>Select Grommet Option</p> <p>N No grommet (only option)</p> <p>N .</p>	<p>Select Laminate</p> <p>C Harvest N Mahogany</p> <p>C .</p>	<p>Select Edge Color</p> <p>C Harvest N Mahogany</p> <p>C</p>
---	--	--	--

66000 SERIES / THE STATIONMASTER®

TABLES



StationMaster® shown with ComforTask® Chair.

66000 SERIES / THE STATIONMASTER®

StationMaster tables from HON are ideal for use both as training tables and as desks. The laminate tops stand up to activity. The sturdy C-style legs provide kneespace. Wire management keeps technology in place.



FEATURES

- Thick laminate worksurface stands up to daily wear and tear.
- Integrated grommets neatly route cables and cords directly to the worksurface.
- Leveling glides compensate for uneven floors.

66000 SERIES ORDERING INFORMATION

LAMINATE

TOPS/L1 LAMINATES CODES

Woodgrain

- ◆ Bourbon Cherry H
- ◆ Harvest C
- ◆ Mahogany N
- ◆ Natural Maple D
- ◆ Shaker Cherry F

Solid

- ◆ Black P
- ◆ Charcoal S
- ◆ Designer White LDW1

Patterned

- ◆ Sheer Mesh A5
- ◆ Silver Mesh B9
- ◆ Steel Mesh A9
- ◆ Canyon Zephyr K9
- ◆ Desert Zephyr K8
- ◆ Shadow Zephyr K1
- ◆ Gray G2
- ◆ Grey Tigris L6
- ◆ White G1
- ◆ Whitestone K4

PAINT

BASE PAINT CODES

P1

- ◆ Black P
- ◆ Brownstone P7D
- ◆ Charcoal S
- ◆ Designer White PJW
- ◆ Fossil P28
- ◆ Greige T5
- ◆ Light Gray Q
- ◆ Loft LOFT
- ◆ Muslin T3
- ◆ Putty L
- ◆ Shadow * SHDW
- ◆ Titanium P8T

P2

- ◆ Champagne Metallic T4
- ◆ Platinum Metallic T1

Recommended Edgeband Color Selection:

Laminate		Edge	
Bourbon Cherry	H	Bourbon Cherry	H
Harvest	C	Harvest	C
Mahogany	N	Mahogany	N
Natural Maple	D	Natural Maple	D
Shaker Cherry	F	Shaker Cherry	F
Black	P	Black	P
Charcoal	S	Charcoal	S
Designer White	LDW1	Designer White	DW
Whitestone	K4	Muslin	T
Sheer Mesh	A5	Muslin	T
Silver Mesh	B9	Loft	LOFT
Steel Mesh	A9	Charcoal	S
Canyon Zephyr	K9	Greige	R
Desert Zephyr	K8	Greige	R
Shadow Zephyr	K1	Loft	LOFT
Gray	G2	Charcoal	S
Grey Tigris	L6	Greige	R

TABLES

◆◆◆ For lead time information see page 19.

* De-emphasized

66000 SERIES

The StationMaster®

GSA SIN 33721



Icon Legend on page 19

TABLES

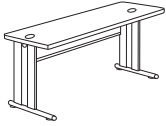
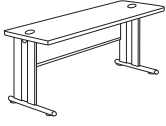
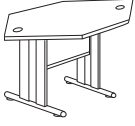
	DESCRIPTION	MODEL	SHIP WEIGHT	CUBE	LIST PRICE BY PAINT GRADE	
					P1	P2
	Desk 29½"H					
	72"W x 29½"D	H66591	129	11.0	\$1182	\$1256
	66"W x 29½"D	H66581	122	10.1	\$1150	\$1224
	60"W x 29½"D	H66571	113	9.2	\$1115	\$1189
	48"W x 29½"D	H66551	95	7.5	\$1039	\$1113
	42"W x 29½"D	H66531	88	6.6	\$994	\$1068
	36"W x 29½"D	H66541	76	5.7	\$957	\$1031
	Desk 29½"H					
	72"W x 24"D	H66597	116	9.1	\$1143	\$1217
	66"W x 24"D	H66582	111	8.1	\$1115	\$1189
	60"W x 24"D	H66577	99	7.7	\$1062	\$1136
	48"W x 24"D	H66557	88	5.7	\$990	\$1064
	42"W x 24"D	H66537	82	5.6	\$944	\$1018
	36"W x 24"D	H66547	77	4.3	\$906	\$980
	Corner Desk					
	29½"H with 24" sides	H66280	96	10.3	\$1426	\$1500
	29½"H with 29½" sides	H66282	104	12.3	\$1503	\$1577

NOTES:

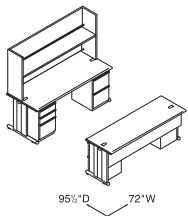

- Tops are 1½" thick.
 - Two leveling glides per leg with ¾" adjustability.
 - Laminate tops have low-glare surfaces and black grommets for wire management.
 - Wire management in C-legs is concealed.
 - Additional accessories and design information on pages 374-375.
- ❗ 66000 Series Tables produced on or after November 2018 will feature 2mm flat edgeband tops. Tables produced before November 2018 feature bullnose edge tops.

HOW TO SPECIFY

Select Model Number H 6 6 5 9 1	Select Grommet G Grommet (no upcharge)	Select Laminate See page 793	Select Paint See page 793
---	--	--	-------------------------------------

UTILITY TABLES



TABLES

Utility Tables shown with Accommodate® Seating.

UTILITY TABLES

All-purpose Utility Tables from HON have a place in every work and educational setting. The Chrome steel legs and square edge detail complement HON 34000 Series desks. The top is scratch-, spill-, and stain-resistant laminate. Adjustable glides won't mar hard-surface floors.



FEATURES

- Scratch-, spill- and stain-resistant laminate stands up to heavy use and is specially treated to withstand boiling liquids.
- Heavy-grade, warp-resistant particleboard withstands high activity.
- Formed steel legs and perimeter frame are built to endure frequent moves and high activity.
- Leveling glides compensate for uneven floors.

UTILITY TABLES ORDERING INFORMATION

LAMINATE

LAMINATES CODES

Woodgrain

- ◆ Bourbon Cherry **H**
- ◆ Cognac **COGN**
- ◆ Florence Walnut **LFW1**
- ◆ Harvest **C**
- ◆ Kingswood Walnut **LK11**
- ◆ Mahogany **N**
- ◆ Mocha **MOCH**
- ◆ Natural Maple **D**
- ◆ Pinnacle **PINC**
- ◆ Shaker Cherry **F**
- ◆ Sterling Ash **LSA1**

Solid

- ◆ Designer White **LDW1**
- ◆ Loft **LOFT**

Patterned

- ◆ Gray **G2**

PAINT

BASE PAINT CODES

P1

- ◆ Black **P**
- ◆ Brownstone **P7D**
- ◆ Charcoal **S**
- ◆ Designer White **PJW**
- ◆ Fossil **P28**
- ◆ Greige **T5**
- ◆ Loft **LOFT**
- ◆ Muslin **T3**
- ◆ Putty **L**
- ◆ Shadow * **SHDW**
- ◆ Titanium **P8T**

LEG FINISH

BASE PAINT CODES

- ◆ Black **P**
- ◆ Chrome **CHR**

Recommended Edgeband Color Selection:

Laminate		Edge	
Bourbon Cherry	H	Bourbon Cherry	H
Cognac	COGN	Cognac	COGN
Florence Walnut	LFW1	Florence Walnut	FW
Harvest	C	Harvest	C
Kingswood Walnut	LK11	Kingswood Walnut	KI
Mahogany	N	Mahogany	N
Mocha	MOCH	Mocha	MOCH
Natural Maple	D	Natural Maple	D
Pinnacle	PINC	Pinnacle	PINC
Shaker Cherry	F	Shaker Cherry	F
Gray	G2	Charcoal	S

◆◆◆ For lead time information see page 19.

* De-emphasized



Icon Legend on page 19

UTILITY TABLES



DESCRIPTION

Rectangle Shaped Utility Table — Metal
72"W x 18"D x 29"H

40"W x 20"D x 29"H
60"W x 20"D x 29"H

60"W x 24"D x 29"H

60"W x 30"D x 29"H
72"W x 30"D x 29"H

72"W x 36"D x 29"H

MODEL	SHIP WEIGHT	CUBE	LIST PRICE
HUTM1872	73	4.8	\$508
HUTM2040	50	3.3	\$420
HUTM2060	68	4.9	\$469
HUTM2460	81	5.6	\$500
HUTM3060	88	6.5	\$514
HUTM3072	106	7.2	\$641
HUTM3672	116	10.4	\$680

NOTES:

- 1/8" thick top with self-edge.
- Adjustable non-marring leveling floor glides.
- 90-degree square corners.
- Legs secured to top with steel corner brace.
- ! 1/4" square Chrome or Black painted legs ONLY.

TABLES

HOW TO SPECIFY

<p>Select Model Number</p> <p>HUTM1872</p>	<p>Select Laminate</p> <p>See page 796</p> <p>MOCH</p>	<p>Select Paint Color</p> <p>See page 796</p> <p>P</p>	<p>Select Leg Paint Color or Finish</p> <p>P Black CHR Chrome</p> <p>CHR</p>
---	---	---	---

CROSS REFERENCE BY APPLICATION

	Page
CLASSROOM	
Student Desks	
SmartLink® Student Desks	808-810
Teacher/Administration Desks	
SmartLink® Teacher Stations	815-817
Voi®	172-233
10700 Series™	295-325
10500 Series™	239-291
Mentor® Series Desks	340-345
38000 Series™	364-377
Seating	
SmartLink® Seating	811-814
Perpetual® Nesting	<i>January 2020 Seating Pricer</i> - 221-223
Olson Stacker® - 4040 Series	
High-Density	<i>January 2020 Seating Pricer</i> - 204-205
Motivate® Seating	<i>January 2020 Seating Pricer</i> - 175-194
Volt® - 5700/5710/5720/5730 Series	
.....	<i>January 2020 Seating Pricer</i> - 286-293
ComforTask® - 5900 Series	<i>January 2020 Seating Pricer</i> - 53-57
Ignition®/Ignition® 2.0	<i>January 2020 Seating Pricer</i> - 133-156
Solve®	<i>January 2020 Seating Pricer</i> - 251-262
Convergence®	<i>January 2020 Seating Pricer</i> - 58-62
Storage & Files	
SmartLink® Modular Storage	818-820
Brigade® 800 Series Lateral Files	616-617
Brigade® 700 Series Lateral Files	618-619
Brigade® 600 Series Lateral Files	620
Lateral File Accessories	676
310 Series Vertical Files - 26½"D	674
510 Series Vertical Files - 25"D	675
Flagship® Bookcases and Storage Cabinets	657-658
Brigade® Storage Cabinets	623
Brigade® Steel Bookcases	622
10500 Series™ Bookcases	683
1870 Series Bookcases	684
Tables	
Huddle Multi-Purpose Tables	736-742
Motivate® Tables	753-757
Build™	699-710
Utility Tables	797
10500 Series™ Shared Components & Accessories	266-274
Learning Applications	
SmartLink® Wall Rail System	821-822
Motivate® Mobile	757
COMPUTER LAB	
Tables	
Huddle Multi-Purpose Tables	736-742
Motivate® Tables	753-757
Between™ Tables	692-696
66000 Series/The StationMaster®	794
Utility Tables	797
Seating	
Motivate® Seating	<i>January 2020 Seating Pricer</i> - 175-194
Perpetual® Nesting	<i>January 2020 Seating Pricer</i> - 221-223

	Page
CAFETERIA	
Seating	
SmartLink® Seating	811-814
Motivate® Seating	<i>January 2020 Seating Pricer</i> - 175-194
Olson Stacker® - 4040 Series	
High-Density	<i>January 2020 Seating Pricer</i> - 204-205
Tables	
Huddle Multi-Purpose Tables	736-742
Motivate® Tables	753-757
Between™ Tables	692-696
COMMON AREAS	
Reception Seating	
Flock® Lounge	<i>January 2020 Seating Pricer</i> - 79-113
Grove®	<i>January 2020 Seating Pricer</i> - 118-130
Accommodate®	<i>January 2020 Seating Pricer</i> - 30-36
Invitation® - 2110 Series	<i>January 2020 Seating Pricer</i> - 158-161
Cambia™ - 2160 Series	<i>January 2020 Seating Pricer</i> - 41-43
Pagoda® - 4070/4090 Series ..	<i>January 2020 Seating Pricer</i> - 206-213
Invitation® Lounge	<i>January 2020 Seating Pricer</i> - 162-164
Tables	
Huddle Multi-Purpose Tables	736-742
Motivate® Tables	753-757
Laminate Occasional Tables	749
10500 Series™ Shared Components & Accessories	266-274
Flock®	727-732
Between™ Tables	692-696
LIBRARY / MEDIA CENTER	
Storage	
Flagship® Bookcases	657
Brigade® Steel Bookcases	622
SmartLink® Modular Storage	818-820
Reception Seating	
Flock® Lounge	<i>January 2020 Seating Pricer</i> - 79-113
Grove®	<i>January 2020 Seating Pricer</i> - 118-130
Accommodate®	<i>January 2020 Seating Pricer</i> - 30-36
Invitation® - 2110 Series	<i>January 2020 Seating Pricer</i> - 158-161
Cambia™ - 2160 Series	<i>January 2020 Seating Pricer</i> - 41-43
Pagoda® - 4070/4090 Series ..	<i>January 2020 Seating Pricer</i> - 206-213
Invitation® Lounge	<i>January 2020 Seating Pricer</i> - 162-164
Student Seating	
SmartLink® Seating	811-814
Motivate® Seating	<i>January 2020 Seating Pricer</i> - 175-194
Accommodate®	<i>January 2020 Seating Pricer</i> - 30-36
Tables	
Huddle Multi-Purpose Tables	736-742
Motivate® Tables	753-757
Laminate Occasional Tables	749
10500 Series™ Shared Components & Accessories	266-274
Flock®	727-732
Between™ Tables	692-696

CROSS REFERENCE BY APPLICATION

	Page
ART ROOM	
Seating	
Motivate® Seating	<i>January 2020 Seating Pricer</i> - 175-194
Storage	
SmartLink® Modular Storage	818-820
Flagship® Storage Cabinets	658
Brigade® Storage Cabinets	623
Flagship® Bookcases	657
Brigade® Steel Bookcases	622
10500 Series™ Bookcases	683
1870 Series Bookcases	684
Tables	
Huddle Multi-Purpose Tables	736-742
Motivate® Tables	753-757
Build™	699-710
Utility Tables	797
TEACHER PLANNING	
Desks	
SmartLink® Teacher Stations	815-817
Voi®	172-233
10700 Series™	295-325
10500 Series™	239-291
Mentor® Series Desks	340-345
38000 Series™	364-377
Seating	
Volt® - 5700/5710/5720/5730 Series	<i>January 2020 Seating Pricer</i> - 286-293
ComforTask® - 5900 Series	<i>January 2020 Seating Pricer</i> - 53-57
Ignition®/Ignition® 2.0	<i>January 2020 Seating Pricer</i> - 133-156
Solve®	<i>January 2020 Seating Pricer</i> - 251-262
Convergence®	<i>January 2020 Seating Pricer</i> - 58-62
Storage	
SmartLink® Modular Storage	818-820
Brigade® 800 Series Lateral Files	616-617
Brigade® 700 Series Lateral Files	618-619
Brigade® 600 Series Lateral Files	620
Flagship® Lateral Files	654-655
400 Series Lateral Files	670
Lateral File Accessories	676
210 Series Vertical Files - 28½"D	673
310 Series Vertical Files - 26½"D	674
510 Series Vertical Files - 25"D	675
Vertical File Accessories	677
Flagship® Storage Cabinets	658
Brigade® Storage Cabinets	623
Flagship® Bookcases	657
Brigade® Steel Bookcases	622
10500 Series™ Bookcases	683
1870 Series Bookcases	684
Tables	
Huddle Multi-Purpose Tables	736-742
Motivate® Adjustable Height Tables	755
Utility Tables	797
Flock®	727-732
Between™ Tables	692-696

	Page
ADMINISTRATION	
Desks	
10700 Series™	295-325
10500 Series™	239-291
Mentor® Series Desks	340-345
38000 Series™	364-377
Reception Seating	
Invitation® - 2110 Series	<i>January 2020 Seating Pricer</i> - 158-161
Cambia™ - 2160 Series	<i>January 2020 Seating Pricer</i> - 41-43
Pagoda® - 4070/4090 Series ..	<i>January 2020 Seating Pricer</i> - 206-213
Task / Administrative Seating	
Ignition®/Ignition® 2.0	<i>January 2020 Seating Pricer</i> - 133-156
Motivate® Seating	<i>January 2020 Seating Pricer</i> - 175-194
Pillow-Soft® - 2190 Series	<i>January 2020 Seating Pricer</i> - 227-229
Volt® - 5700/5710/5720/5730 Series	<i>January 2020 Seating Pricer</i> - 286-293
ComforTask® - 5900 Series	<i>January 2020 Seating Pricer</i> - 53-57
Solve®	<i>January 2020 Seating Pricer</i> - 251-262
Convergence®	<i>January 2020 Seating Pricer</i> - 58-62
Storage & Files	
SmartLink® Modular Storage	818-820
Brigade® 800 Series Lateral Files	616-617
Brigade® 700 Series Lateral Files	618-619
Brigade® 600 Series Lateral Files	620
Lateral File Accessories	676
310 Series Vertical Files - 26½"D	674
510 Series Vertical Files - 25"D	675
Flagship® Bookcases and Storage Cabinets	657-658
Brigade® Storage Cabinets	623
Brigade® Steel Bookcases	622
10500 Series™ Bookcases	683
1870 Series Bookcases	684
Tables	
Huddle Multi-Purpose Tables	736-742
Motivate® Adjustable Height Tables	755
Utility Tables	797
Flock®	727-732
Between™ Tables	692-696
Occasional Tables	
Laminate Occasional Tables	749
10500 Series™ Shared Components & Accessories	266-274
Flock®	727-732

SMARTLINK®



SmartLink® Chairs, Desks, Teacher's Station and Storage.

SmartLink® Value Mobile Storage units were added in 2020 and are not featured in this pricer. Please click [here](#) to see the SmartLink® Value Mobile Storage pricer.

LEARNING

SMARTLINK®

As our research indicates, traditional lecture formats are giving way to group sessions and mentoring. This demands environments that are open, accessible, and accommodate the need for a variety of learning opportunities. HON designed SmartLink to be lightweight and mobile, which helps teachers respond to the ways students learn today, and adapt to new ways of learning tomorrow.



FEATURES

- Put teachers in control of their storage, technology and environment.
- Worksurface shape supports creative configurations.
- Designed to the unique ways students sit and move throughout the day.
- Organize lesson plans and make the most of unused wall space.
- Move educational tools wherever the activities demand.
- SmartLink chairs warranted for users up to 300 lbs.

SMARTLINK® ORDERING INFORMATION

TEACHER DESK & MODULAR STORAGE

LAMINATES CODES

- L1**
 ◆ Harvest CC
 ◆ Natural Maple DD
 ◆ Sheer Mesh A5
 ◆ Silver Mesh B9

PAINTS CODES

- P1**
 ◆ Charcoal S

- P2**
 ◆ Platinum Metallic T1

EDGE CODES

- ◆ Charcoal S
 ◆ Platinum K

STUDENT DESK

PLASTIC CODES

- ◆ Breeze G9
 ◆ Harvest CC
 ◆ Natural Maple DD
 ◆ Sand G8
 ◆ White G1

PAINTS CODES

- P1**
 ◆ Charcoal S

- P2**
 ◆ Platinum Metallic T1

VALUE TEACHER DESK

LAMINATES CODES

- L1**
 ◆ Black P
 ◆ Bourbon Cherry H
 ◆ Charcoal S
 ◆ Cognac COGN
 ◆ Designer White LDW1
 ◆ Florence Walnut LFW1
 ◆ Harvest C
 ◆ Kingswood Walnut LK11
 ◆ Loft LOFT
 ◆ Mahogany N
 ◆ Mocha MOCH
 ◆ Natural Maple D
 ◆ Pinnacle PINC
 ◆ Shaker Cherry F
 ◆ Sheer Mesh A5
 ◆ Silver Mesh B9
 ◆ Steel Mesh A9
 ◆ Sterling Ash LSA1

- L2**
 ◆ Lowell Ash LLA1
 ◆ Natural Recon LNR1
 ◆ Phantom Ecru LPE1
 ◆ Portico Teak LPT1
 ◆ Skyline Walnut LSW1

PAINTS CODES

- P1**
 ◆ Charcoal S
 ◆ Designer White PJW

- P2**
 ◆ Platinum Metallic T1
 ◆ Silver PR6

- P3**
 ◆ Atom P8S
 ◆ Bullseye PJF
 ◆ Ember P8P
 ◆ Ion P8N
 ◆ Iris P8J
 ◆ Krypton P8F
 ◆ Regatta P8M

EDGE CODES

- ◆ Atom AT
 ◆ Bullseye BY
 ◆ Charcoal S
 ◆ Ember MR
 ◆ Ion IO
 ◆ Iris IR
 ◆ Krypton KT
 ◆ Platinum K
 ◆ Regatta RE

VALUE STUDENT DESK

PLASTIC CODES

- ◆ Breeze G9
 ◆ Harvest CC
 ◆ Natural Maple DD
 ◆ Sand G8
 ◆ White G1

PAINTS CODES

- P1**
 ◆ Charcoal S

- P2**
 ◆ Platinum Metallic T1

P3

- ◆ Atom P8S
 ◆ Bullseye PJF
 ◆ Ember P8P
 ◆ Ion P8N
 ◆ Iris P8J
 ◆ Krypton P8F
 ◆ Regatta P8M

UNIVERSAL MODESTY PANEL

PAINTS CODES

- P1**
 ◆ Black P
 ◆ Brownstone P7D
 ◆ Charcoal S
 ◆ Designer White PJW
 ◆ Fossil P28
 ◆ Greige T5
 ◆ Light Gray Q
 ◆ Loft LOFT
 ◆ Muslin T3
 ◆ Putty L
 ◆ Shadow SHDW
 ◆ Textured Black Mica BLCK
 ◆ Titanium P8T

P2

- ◆ Champagne Metallic T4
 ◆ Platinum Metallic T1
 ◆ Silver PR6
 ◆ Solar Black P8X
 ◆ Textured Platinum
 Metallic PLAT
 ◆ Textured Silver PR8

P3

- ◆ Atom P8S
 ◆ Bullseye PJF
 ◆ Ember P8P
 ◆ Ion P8N
 ◆ Iris P8J
 ◆ Krypton P8F
 ◆ Regatta P8M

4-LEG, CANTILEVER CHAIR, TASK CHAIR, STOOL SHELLS

SHELL CODES

- ◆ Calypso CP
 ◆ Cherry CR
 ◆ Lava LA
 ◆ Lime LM
 ◆ Mulberry MB
 ◆ Onyx ON
 ◆ Platinum PT
 ◆ Regatta RE
 ◆ Shadow SD
 ◆ Surf BU
 ◆ Tangelo RG

4-LEG AND CANTILEVER CHAIR AND STOOL FRAME

PAINTS CODES

- P1**
 ◆ Designer White Texture PK7
 ◆ Textured Charcoal P7A

- P2**
 ◆ Platinum Metallic Texture PLAT
 ◆ Silver Texture PR8

P3

- ◆ Atom P8S
 ◆ Bullseye PJF
 ◆ Ember P8P
 ◆ Ion P8N
 ◆ Iris P8J
 ◆ Krypton P8F
 ◆ Regatta P8M

- P4**
 ◆ Polished Chrome* Y

LEARNING

* \$52 upcharge. Polished Chrome not available on 6"H model HSS4L-06A.

◆◆◆ For lead time information see page 19.

* De-emphasized





SMARTLINK® SPECIFYING INFORMATION

FINDING THE RIGHT FIT FOR YOUR STUDENT DESK & CHAIR

With the SmartLink® student desk's innovative shape, you can create dynamic learning environments and every space can be tailored to fit the lesson plan whether the need is for individual, student/group collaboration or teacher centered layouts. In addition to the desk's innovative top shape you can also select from three leg configurations to meet your specific needs for classroom or collaborative spaces.

STEP 1



Choose a grade range to find the recommended SmartLink® desk height.

 <p>K-2nd Seated 22"-27" Standing 24"-30"</p>	 <p>3rd-5th Seated 23"-29" Standing 29"-35"</p>	 <p>6th-8th Seated 25"-30" Standing 32"-40"</p>	 <p>9th & Up Seated 29"-30" Standing 38"-43"</p>
---	---	---	--

LEARNING

STEP 2

Pick the SmartLink® model that meets the student height needs.

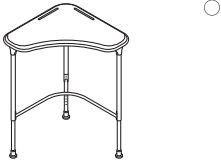
 <p>Model: HLD-M3A Adjustable Height 23"-33" Height Range</p>	<p>Use the color-coated circles in the chart on the right to find a compatible chair.</p>	
 <p>Model: HLD-M3F Fixed Height 30" Fixed Height</p>	 <p>Model: HLD-M3T Sit-to-Stand 30"-43" Height Range</p>	

STEP 3

Determine the suggested chair height within your desk size range.

Desk Height	Chair Seat Height	Type of Chair
22"	12"	4-Leg, Cantilever or Task
23-24"		
25-27"		
28-29"		
30"	18"	Stool
31-33"	22-23"	
34-41"	23-31"	
42-43"	32"	

SMARTLINK[®] SPECIFYING INFORMATION

Individual Layouts

- The non-handed top allows the desk to be positioned to better support right-handed or left-handed individuals or be used in a forward position.



LH Position



Forward Position



RH Position

Group/Collaborative Layouts

Below are examples of how the student desks can be configured to support multiple students or group activities.

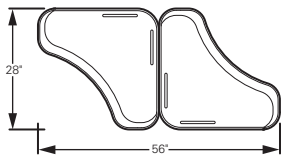

Student Desk
2-Desk Configuration

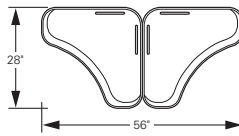

Opposing Student Desk
2-Desk Configuration

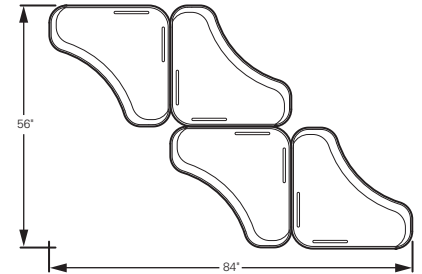

Student Desk
4-Desk Configuration

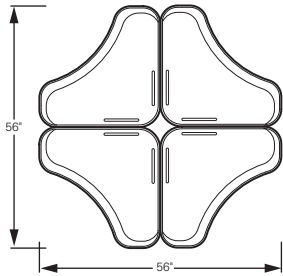

Student Desk
4-Desk Cluster Configuration

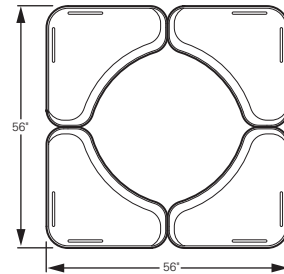

Student Desk
4-Desk Work Group Configuration
Can accommodate up to 8 students

Teacher Centered Layouts

- Reverse the layout and use the student desks to create layouts for teacher centers that can accommodate up to 6 students.
- 23 $\frac{5}{8}$ " distance between legs when used from either side.

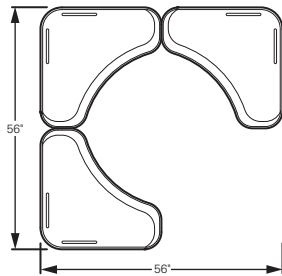

Teacher Centered Layout

Standard Row Layout

While a variety of classroom configurations are possible, a standard row layout shown below with 25 student desks utilizes a footprint of 199" deep by 284" wide. A 30 student desk row layout (5 rows deep by 6 rows wide) will require a footprint of 199" deep by 348" wide.

These dimensions are based upon 36"W aisles. Actual dimensions should be based upon local building codes.

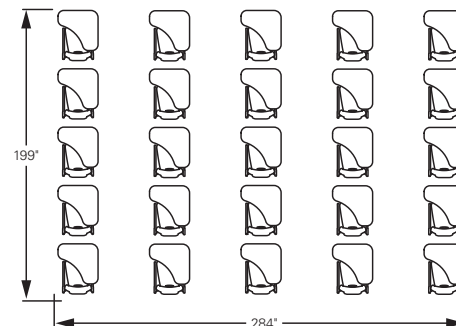

SMARTLINK® SPECIFYING INFORMATION

TEACHER STATION

SmartLink®

The following planning and specifying information is intended to help you imagine and create stimulating SmartLink classrooms that can integrate technology while helping rooms stay adaptable, organized and attractive. SmartLink offers you everything you need to create flexible, clutter-free learning environments for students of all ages.

Teacher Station – Standard Double Pedestal

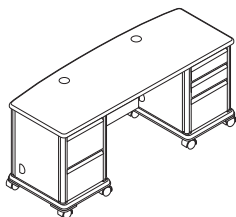

HLT2672-23.C

Storage

- Box/box/file pedestal is always standard on the right-hand side. Pedestal is locking.
- Available kneespace is 33 $\frac{1}{4}$ "W x 20"D for all models.
- Non-locking Center Drawer (HD8X) may be field installed in the kneespace. Tops are pre-drilled to accept the drawer.
- Center drawers and CPU holders cannot be installed together.

Cable Management

- Both the left-hand and right-hand end panels may be removed to provide access to power and cable management within the side power cabinet.
- Grommets are standard in each removable end panel allow a power cord to exit and be plugged into a floor or wall outlet.
- Two "Smart Grommets" with a wireway cover are standard on each station's top surface.

Teacher Station – Standard Single Pedestal

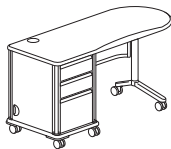

HLT2460-L3.C

Storage

- Single pedestal desk available in Left-hand or Right-hand pedestal/storage configurations.
- Pedestal options include Box/Box/File locking.

Cable Management

- The pedestals end panel may be removed to provide access to power and cable management within the side power cabinet.
- A grommet is standard in the removable end panel to allow a power cord to exit and be plugged into a floor or wall outlet.
- A single "Smart Grommet" with a wireway cover is standard on each station's top surface.

Teacher Station – Value Double Pedestal

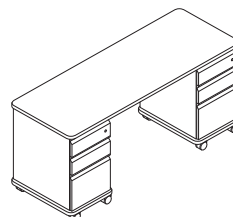

HLTV2466T-33

- Larger top size provides ample work/conference area or space for equipment.
- Standard with Heavy-duty 3", 360-degree swivel casters, 4-locking, 4-non-locking.
- Storage options include: Locking box/box/file.
- Kneewell space accommodates optional (specified separately) and field installed non-locking center drawer and CPU holders (see page 817).
- Modesty specified separately.
- Power modules can be ordered separately and mounted to the desk. See Power & Cable Management page 849.

Teacher Station – Value Single Pedestal



HLTV2460T-3

- Standard with Heavy-duty 3", 360-degree swivel casters, 4-locking, 4-non-locking.
- Storage options include: Locking box/box/file.
- Kneewell space accommodates optional (specified separately) and field installed non-locking center drawer and CPU holders (see page 817).
- Right or left assembled in the field.
- D-shape top encourages conferencing and provides ample work and conference area.
- Modesty specified separately.
- Power modules can be ordered separately and mounted to the desk. See Power & Cable Management page 849.

SMARTLINK® SPECIFYING INFORMATION

MODULAR STORAGE

SmartLink® Modular Storage is comprised of cases, accessories and support rails. However, only the cases and accessories need to be specified. The following guidelines should help you plan and specify SmartLink Storage.

Planning Notes

Cases

- A laminate top with a soft feel vinyl edge provides a classic look with exceptional durability.
- **Storage cases do NOT include accessories. Accessories are specified and sold separately.**
- Case configurations are based off of 12"W or 30"W columns.
- Internal case configurations cannot be changed (i.e., cannot change an HLSF52-3 to a HLSF52-21).
- Cases are designed to allow the users to create a variety of accessory configurations using different tray heights and shelves.
- Cases can be specified with or without locking doors.
- Door models may be converted to non-door models in the field.

Accessories

- Accessories include trays in 3", 6" and 12" heights, shelves in 12" and 30" widths and a 12"W coat rod.
- **All accessories are sold and specified separately as kits and include 1 pair of storage rails per tray or shelf.**
- The support rails simple "no tool" attachment method allows users to easily install and change rail (tray or shelf) positions as needed.
- Kits include:

Accessory	Quantity Per Kit	Where Used
3"H trays	7 trays / 14 support rails	12"W columns only
6"H trays	4 trays / 8 support rails	12"W columns only
12"H trays	2 trays / 4 support rails	12"W columns only
12"W shelf	2 shelves / 4 support rails	12"W columns only
30"W shelf	2 shelves / 4 support rails	30"W columns only
Coat Rod	1 coat rod	12"W columns — Full Height case only

- Cabinet Bracket kit is available which allows to be mounted to the back of the full height cabinets. Kit includes upper and lower rails with integrated marker tray and attachment hardware. Use wall rail sliding. Rails will accept one (1) 48" x 48" board or two (2) 24" x 48" boards.

Specification Notes

- Number of accessory openings
SmartLink storage cases are available in six (6) standard case types that feature combinations of 12" or 30" internal column widths. The following illustration shows the number of openings by column width for each case configuration.

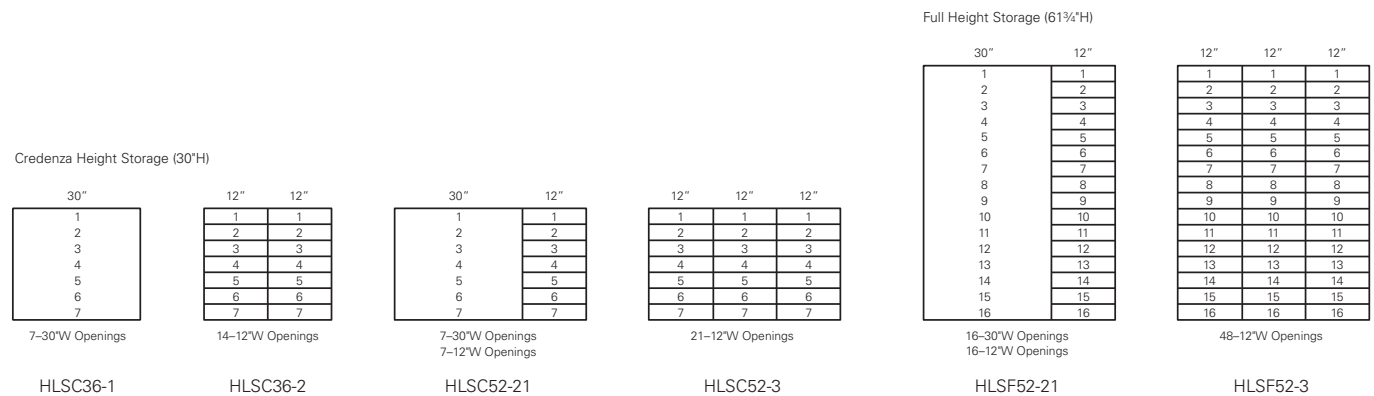

SMARTLINK® SPECIFYING INFORMATION

- Openings used by Accessory type:

Accessory	Openings used per Accessory
3"H tray	1
6"H tray	2
12"H tray	4
12"W shelf	1
30"W shelf	1

- Any combination of trays or shelves (of common width) can be used as long as the openings used equal the total number of openings available per column. The following illustrations show a variety of tray configuration options. Numbers shown in the opening refers to the tray size.

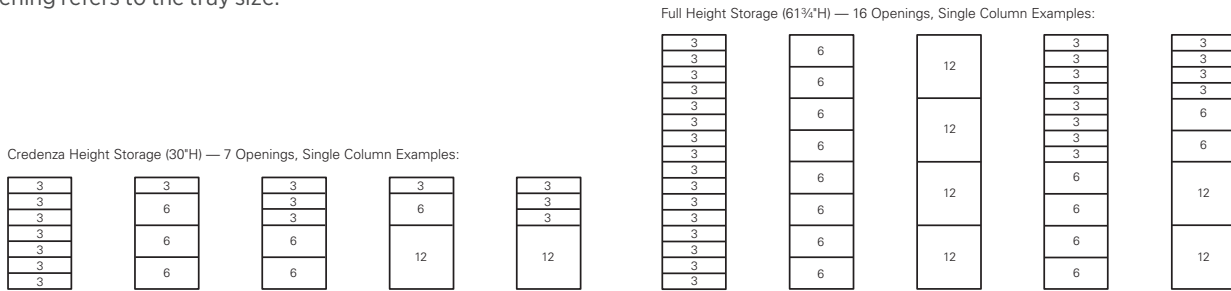

Using the information above, follow these guidelines to help determine accessory quantities.

- Determine the total number of available "openings" by width (12", 30") for each case type.
Example: HLSF52T-3F has 3 columns of 16 openings, total 48 openings
- On a PER COLUMN basis, determine the desired tray/shelf configurations total number of openings used so they equal the total openings available per column. Total accessory quantities per case then multiply by the total number of like cases.
Example: If each column will have 2-12" trays, 2-6" trays and 4-3" trays. The number of openings used for this column combination is 16. Assuming all three columns are the same total tray quantities for this case will be 12-3", 6-6" and 6-12".
- Once total tray and shelf quantities are determined, simply divide by the kit quantity to determine the number of kits required.
Example: 3" trays = $12 \div 7 = 2$ kits, 6" trays = $6 \div 4 = 2$ kits, 12" trays = $6 \div 2 = 3$ kits

Shelf Spacing

The clearance between shelves is approximately 3 3/8" for every support rail that is not used between shelves. The following illustration shows the clearance between shelves when 0-4 support rail positions are not utilized.

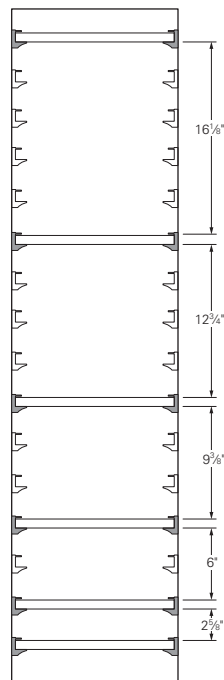

SMARTLINK® SPECIFYING INFORMATION

WALL RAIL SYSTEM

The SmartLink® wall rail is a multi-layered, multi-functional system that can accommodate a variety of presentation boards and accessories. The multiple tracks allow boards to be easily positioned and changed to support today's interactive learning environments.

Planning Notes

- Installation of the wall rail system over existing white or chalkboards is not recommended.
- The rail and wall bracket provide three separate tracks for the Learning boards. The REAR or wall/bracket track is occupied by the fixed wall board. The MIDDLE and FRONT tracks are for sliding boards.
- To allow for greater utilization of the rear fixed board a maximum width of 96" of sliding boards on the middle or front track is recommended.

The illustration below shows the overall wall space requirements for the rail system and recommended mounting height for use in K-12 classroom applications.

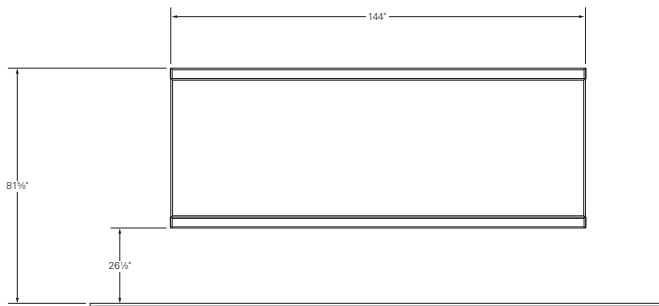

Sliding boards are removable and reversible so a wide variety of layouts are possible. The following illustrations highlight a couple of the more common applications. Layouts 2A and 2B provide the greatest amount of board space and overall flexibility. When used with rail mounted worksurfaces, use 24"W boards on the front rail as shown in 2C in front of each worksurface to provide information specific to that work area. Boards could then be added to the middle rail for information/work to be shared between the stations.

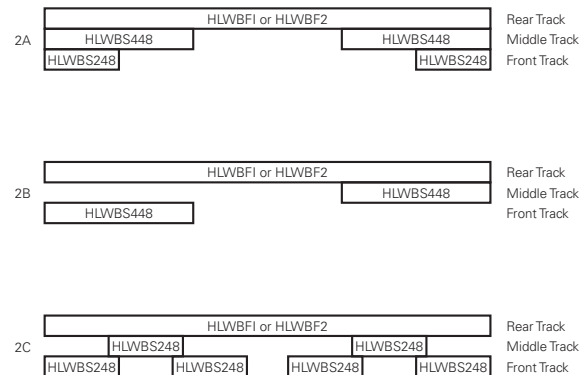

Specification Notes





- Boards are specified individually.
- Hardware to mount to the wall brackets is not provided by HON and MUST BE SOURCED LOCALLY.
- Learning board only applications require two (2) HLWR-12 rails to be specified.
- REFER TO PRODUCT INSTALLATION INSTRUCTIONS FOR DETAILED INSTALLATION INFORMATION.

SMARTLINK® Student Desks

GSA SIN 3372IT



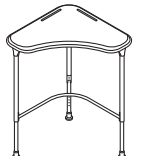

Icon Legend on page 19

	DESCRIPTION	MODEL	SHIP WEIGHT	CUBE	LIST PRICE
	Student Desk, Fixed Height 28"W x 28"W, User side 36¼"W 30" Fixed Height Hard Plastic Top Ships  Ships Assembled Ships Assembled with HLDA-15 Book Box attached	HLD-M3F	63	5.5	\$720
		HLD-M3FA	58	17.9	\$760
		HLD-M3FB	65	17.9	\$877
	Student Desk, Adjustable Height 28"W x 28"W, User side 36¼"W Adjustable: 23"-33" height adjustment range. Legs ship pre-set for 30" overall desk height when factory installed. Hard Plastic Top Ships  Ships Assembled Ships Assembled with HLDA-15 Book Box attached	HLD-M3A	63 	5.5	\$720
		HLD-M3AA	58	17.9	\$760
		HLD-M3AB	65	17.9	\$877
	Student Desk, Sit-to-Stand 28"W x 28"W, User side 36¼"W Adjustable: 30"-43" height adjustment range. Leg height is set during field installation. Hard Plastic Top	HLD-M3T	65	5.5	\$1024

NOTES:

- Non-handed desk top constructed of ¾" hard plastic, includes dual pencil grooves.
- Hard plastic top features comfort edge on user side and soft radius with rounded corners on all sides.
- May also be specified to ship fully assembled, with or without HLDA-15 Book Box.
- Upper leg is painted, lower leg standard chrome finish on Adjustable and Sit-to-Stand models.
- Nylon swivel glides are standard on adjustable and fixed leg models.
- 29.60" distance between legs on user side. Outside distance between legs is 23⅜".
- Sit-to-Stand model features bell glides.
- Sit-to-Stand is height adjustable from 30"-43"H and includes a footrest.
- Accepts optional book box (HLDA-15) and backpack hooks (HCLA65).

 Field installed felt glide caps (HGDK3-F) are recommended for use on VCT flooring.

 All Student Desks are ordered and shipped two (2) desks per carton. Legs and cross-brace ship unattached on  models. Pricing shown is per carton. Ordering two of model HLD-M3A or HLD-M3T will result in 2 cartons being shipped, giving you 4 desks.

HOW TO SPECIFY

Select Model Number H L D - M 3 A .	Select Glide Option E Hard-Surface (no upcharge) (Fixed or Adjustable models only) G Bell Glide (Sit-to-stand model only) E .	Select Top Color See page 801 G 9 .	Select Upper Leg Color See page 801 S
---	---	--	--

SMARTLINK® Value Series Student Desks

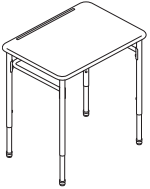
	DESCRIPTION	MODEL	SHIP WEIGHT	CUBE	LIST PRICE BY PAINT GRADE		
					P1	P2	P3
	Student Desk, Fixed Height 28"W x 28"W, User side 36¼"W 30" Fixed Height Hard Plastic Top	HLDV-M3F	63	18.0	\$606	\$606	\$636
	NOTES: The cross-brace is installed to maximize kneespace but will not allow for book basket (HLDA-15) installation. The cross-brace orientation can be switched in the field to allow for book basket install.						
	ⓘ Student Desks are ordered and shipped two (2) desks per carton. Legs and cross-brace ship attached. The cross-brace is installed to maximize kneespace but will not allow for book basket (HLDA-15) installation. Pricing shown is <u>per carton</u> . Ordering two of model HLDV-M3F will result in 2 cartons being shipped, giving you 4 desks.						
	Student Desk, Adjustable Height 28"W x 28"W, User side 36¼"W Adjustable: 23"-33" height adjustment range. Hard Plastic Top	HLDV-M3A	59	12.5	\$606	\$606	\$636
	SPECIFICATION TIP: Consider available kneespace when specifying under desk storage Wire Book Box. Available kneespace will vary significantly given set desk height. Use the following example to calculate the available and usable kneespace. EXAMPLE: HLDV-M3A Student Desk, HLDA-15 Wire Book Box (user set desk height – top thickness – seat height = available kneespace) (29"H – 1" thickness – 18" seat height = 10" available kneespace) (available kneespace – book basket/box height = usable kneespace) (10" available kneespace – 5" basket height = 5" usable kneespace)						
	NOTES: Accepts book basket (HLDA-15) installation without repositioning crossbar.						
	ⓘ Student Desks are ordered and shipped two (2) desks per carton. Upper leg and cross-brace ship attached. Lower adjustable legs ship unattached for field installation. Pricing shown is <u>per carton</u> . Ordering two of model HLDV-M3A will result in 2 cartons being shipped, giving you 4 desks.						
	Rectangle Student Desk, Adjustable Height 20"W x 26"D Adjustable: 23"-33" height adjustment range.	HLDV-MRECT2026A	57	9.19	\$606	\$606	\$636
	NOTES: Accepts book basket (HLDA-15) installation without repositioning crossbar.						
	ⓘ Student Desks are ordered and shipped two (2) desks per carton. Legs and cross-brace ship attached. Pricing shown is <u>per carton</u> . Ordering two of model HLDV-MRECT2026A will result in 2 cartons being shipped, giving you 4 desks.						

NOTES:

- Upper leg is painted, lower leg standard chrome finish on Adjustable Height models.
- Non-handed desk top constructed of ¾" hard plastic.
- Hard plastic tops include pencil grooves.
- Nylon swivel glides are standard on adjustable and fixed leg models.
- Fixed Height models ship fully assembled. Adjustable models have the upper leg and cross-brace installed. The lower leg ships unattached for field installation.
- 29.60" distance between legs on user side. Outside distance between legs is 23⅞".
- Accepts optional backpack hooks (HCLA65).
- Book boxes are only available as an accessory for field installation on Value Series desks.
- ! Field installed felt glide caps (HGDK3-F) are recommended for use on VCT flooring.
- ! All Student Desks are ordered and shipped two (2) desks per carton. Ordering two of any model will result in 2 cartons being shipped, giving you 4 desks.

HOW TO SPECIFY

Select Model Number H L D V - M 3 F .	Select Glide Option E .	Select Top Color See page 801 G 9 .	Select Upper Leg Color See page 801 S
---	-----------------------------------	--	--

SMARTLINK® Student Accessories

GSA SIN AS NOTED

ABI

Icon Legend on page 19

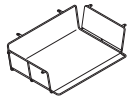

SIN 33721T



DESCRIPTION

Wire, Book Box (4 per carton)
19½"W x 13"D x 5"H

MODEL

SHIP WEIGHT

CUBE

LIST PRICE

HLDA-15

15 Ⓢ

2.0

\$258

NOTES: Attaches to bottom of desk with 6 screws, included. Field installed. For use on model HLD-M3A, HLD-M3F, HLDV-MRECT2026A or HLD-M3T. Features integrated, full-width pencil holder. Bent wire and perforated steel construction for durability and visibility.

ⓘ Platinum finish only.

Must be ordered with a configurable end product. If ordered separately, not on GSA Contract.

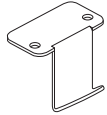

OPEN MARKET



Back Pack Hook (10 per carton)

HCLA65

10 Ⓢ

0.1

\$94

NOTES: Assembly: attaches to bottom of desk with (2) screws, included. For additional information see page 846.

ⓘ Available in Platinum Metallic finish only, no specification needed.



OPEN MARKET

Glide Kit — Felt Glide Caps

HGDK3-F

2 Ⓢ

0.2

\$124

- Recommended for use on VCT flooring.
- Caps easily and securely snap over existing nylon swivel glide.
- Kit includes 100 caps.
- Field installed.

ⓘ Not designed to be used with Sit-to-Stand Bell Glides (model HLD-M3T).

Must be ordered with a configurable end product. If ordered separately, not on GSA Contract.





LEARNING

HOW TO SPECIFY

Select
Model Number

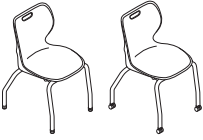
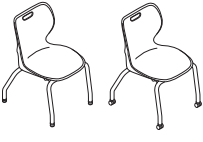
H L D A - 1 5



	MODEL/DESCRIPTION	DEPTH	WIDTH	HEIGHT	SHIP WEIGHT	CUBE	PER CARTON LIST
	HSS4L-18B 18"H 4-Leg Chair, Armless	Maximum: 19 ⁵ / ₈ Seat: 16 ¹ / ₄ Back: 15 ³ / ₈ Seat to Floor: 18 Usable Seat Depth: 16 ¹ / ₈	19 ¹ / ₂	31	58	15.6	P1 \$583 (reference single unit @ \$145.75) P2 \$583 (reference single unit @ \$145.75) P3 \$612 (reference single unit @ \$153.00)
	HSS4L-16B 16"H 4-Leg Chair, Armless	Maximum: 19 ⁵ / ₈ Seat: 16 ¹ / ₄ Back: 15 ³ / ₈ Seat to Floor: 16 Usable Seat Depth: 16 ¹ / ₈	19 ¹ / ₄	29	54	15.6	P1 \$583 (reference single unit @ \$145.75) P2 \$583 (reference single unit @ \$145.75) P3 \$612 (reference single unit @ \$153.00)
	HSS4L-14A 14"H 4-Leg Chair, Armless	Maximum: 17 Seat: 14 ¹ / ₄ Back: 13 ³ / ₈ Seat to Floor: 14 Usable Seat Depth: 14	17	25 ¹ / ₂	49	11.9	P1 \$554 (reference single unit @ \$138.50) P2 \$554 (reference single unit @ \$138.50) P3 \$582 (reference single unit @ \$145.50)
	HSS4L-12A 12"H 4-Leg Chair, Armless	Maximum: 17 Seat: 14 ¹ / ₄ Back: 13 ³ / ₈ Seat to Floor: 12 Usable Seat Depth: 14	17	23 ¹ / ₂	45	11.9	P1 \$554 (reference single unit @ \$138.50) P2 \$554 (reference single unit @ \$138.50) P3 \$582 (reference single unit @ \$145.50)
	HSS4L-06A 6"H 4-Leg Chair, Armless	Maximum: 17 Seat: 14 ¹ / ₄ Back: 13 ³ / ₈ Seat to Floor: 6 Usable Seat Depth: 14	17	17 ¹ / ₂	37	8.6	P1 \$540 (reference single unit @ \$135.00) P2 \$540 (reference single unit @ \$135.00) P3 \$567 (reference single unit @ \$141.75)

NOTES:

- High strength tubular steel frame.
- Seat Shell is one-piece injection molded.
- 16"H and 18"H models accept Wire Storage Basket model HSSA-WB1618.
- Casters are available on 16"H and 18"H chairs only.
- 4-Leg models stack 5-high on floor.
- Nylon or steel glides accept felt glide caps (HGDK3-F) which are recommended for use on VCT flooring.
- Durable textured powder coated paint finish or chrome option finish.





SmartLink® 4-Leg Chairs are ordered and shipped four (4) chairs per carton. Pricing shown is per carton. Each set of four chairs (one carton) must have the same shell/frame color combination. Ordering 2 of Model HSS4L-06A, HSS4L-12A, HSS4L-14A, HSS4L-16B or HSS4L-18B will result in 2 cartons being shipped, giving you 8 chairs.

HOW TO SPECIFY

<p>Select Model Number</p> <p>HSS4L-12A</p>	<p>Select Glide Option</p> <p>E Nylon Glide N Nickel Steel Glide C Caster (\$196 upcharge) Caster option not available for models HSS4L-06A, HSS4L-12A or HSS4L-14A</p> <p>E</p>	<p>Select Shell Color</p> <p>See page 801</p> <p>RG</p>	<p>Select Frame Color</p> <p>See page 801 <i>P4 option Polished Chrome (Y) \$52 upcharge</i></p> <p>PLAT</p>
--	---	--	---

LEARNING

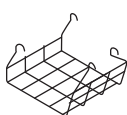

	MODEL/DESCRIPTION	DEPTH	WIDTH	HEIGHT	SHIP		LIST PRICE BY PAINT GRADE		
					WEIGHT	CUBE	P1	P2	P3
	HSS4L-24B 24"H 4-Leg Stool, Armless				30	16.8	\$283	\$283	\$298
	Maximum:	21½	22	38¼					
	Seat:	16¼	16½	24					
	Back:		15¾	13¾					
	Seat to Floor:			24					
	Usable Seat Depth:	30							
	HSS4L-30B 30"H 4-Leg Stool, Armless				31	19.1	\$298	\$298	\$313
	Maximum:	23½	22½	43¾					
	Seat:	16¼	16½	30					
	Back:		15¾	13¾					
	Seat to Floor:			30					
	Usable Seat Depth:	30							
	DESCRIPTION	MODEL			SHIP WEIGHT	CUBE	LIST PRICE		
	Wire Storage Basket (4 per carton) 15¾"W x 12¼"D x 9¾"H	HSSA-WB1618			14	1.6	\$138		
	<ul style="list-style-type: none"> For 16" and 18" 4-Leg Chairs only. Chrome finish only, no specification needed. Chairs cannot be stacked when utilizing Wire Storage Basket. Not compatible with 4-Leg Stools or Cantilever Chairs. 								
	Felt Cap Glide Kit for 4-Leg SmartLink®	HGDK3-F			2	0.2	\$124		
	<ul style="list-style-type: none"> Recommended for use on VCT flooring. Caps easily and securely snap over the existing nylon swivel glide. Kit includes 100 caps for 25 chairs or desks. Field installed. <p>Must be ordered with a configurable end product. If ordered separately, not on GSA Contract.</p>								



NOTES:

- 4-Leg Stools may stack up to 5-high on floor.
- Lead times may vary by shell color.

HOW TO SPECIFY

<p>Select Model Number</p> <p>H S S 4 L - 2 4 B</p>	<p>Select Glide Option</p> <p>E Nylon Glide N Nickel Steel Glide</p> <p>E</p>	<p>Select Shell Color</p> <p>See page 801</p> <p>R G</p>	<p>Select Frame Color</p> <p>See page 801 P4 option Chrome (Y) \$52 upcharge</p> <p>P L A T</p>
--	--	---	--



	MODEL/DESCRIPTION	DEPTH	WIDTH	HEIGHT	SHIP WEIGHT	CUBE	PER CARTON LIST
	HSSCL-18B 18"H Cantilever Base Chair, Armless				80	23.7	P1 \$845 (reference single unit @ \$211.25)
	Maximum:	21¾	22¾	31¼			P2 \$845 (reference single unit @ \$211.25)
	Seat:	16⅞	16½	18			P3 \$887 (reference single unit @ \$221.75)
	Back:		15⅝	13⅜			
	Usable Seat Depth:	16⅞		18¼			
	HSSCL-16B 16"H Cantilever Base Chair, Armless				55	16.8	P1 \$804 (reference single unit @ \$201.00)
	Maximum:	21¾	22¾	29¼			P2 \$804 (reference single unit @ \$201.00)
	Seat:	16⅞	16½	16			P3 \$844 (reference single unit @ \$211.00)
	Back:		15⅝	13⅜			
	Usable Seat Depth:	16⅞		16¼			
	HSSCL-14A 14"H Cantilever Base Chair, Armless				52	16.8	P1 \$789 (reference single unit @ \$197.25)
	Maximum:	21¾	22¾	27¼			P2 \$789 (reference single unit @ \$197.25)
	Seat:	16⅞	16½	14			P3 \$828 (reference single unit @ \$207.00)
	Back:		15⅝	13⅜			
	Usable Seat Depth:	16⅞		14¼			



NOTES:

- High strength tubular steel frame.
- Glides available with nylon or felt inserts. See ordering information below.
- Seat shell is one-piece injection molded.
- Cantilever models stack 5-high on floor.
- Durable textured powder coated paint or chrome option finish.

SmartLink® Cantilever Chairs are ordered and shipped four (4) chairs per carton. Pricing shown is per carton. Each set of four chairs (one carton) must have the same shell/frame color combination. Ordering 2 of Model HSSCL-18B will result in 2 cartons being shipped, giving you 8 chairs.

HOW TO SPECIFY

<p>Select Model Number</p> <p>H S S C L - 1 8 B .</p>	<p>Select Glide Option</p> <p>E All-purpose Glide Insert (no upcharge) F Felt Glide Insert (\$36 list upcharge; \$9 per single unit see page 810)</p> <p>E .</p>	<p>Select Shell Color</p> <p>See page 801</p> <p>R G .</p>	<p>Select Frame Color</p> <p>See page 801 <i>P4 option Polished Chrome (Y) \$52 upcharge</i></p> <p>P L A T</p>
--	--	---	---

	MODEL/DESCRIPTION	DEPTH	WIDTH	HEIGHT	SHIP WEIGHT	CUBE	PER CARTON LIST
	HSSTK-18B 18"H Task Swivel Chair, Pneumatic Seat Height Adjustment Maximum: 22 ⁵ / ₈ Seat: 16 ¹ / ₄ Back: 15 ³ / ₈ Seat to Floor: 16-21 Usable Seat Depth: 16 ¹ / ₈ ! Black frame only.	22 ⁵ / ₈	22 ¹ / ₂	34 ³ / ₄ 18 13 ³ / ₈ 16-21	23	5.2	\$281
	HSSST-18B 18"H Task Swivel Stool, Pneumatic Seat Height Adjustment, Footring Adjustment Maximum: 24 ¹ / ₄ Seat: 16 ¹ / ₄ Back: 15 ³ / ₈ Seat to Floor: 22-32 Usable Seat Depth: 16 ³ / ₈ ! Black frame only.	24 ¹ / ₄	25 ³ / ₄	45 ¹ / ₂ 18 13 ³ / ₈ 22-32	28	12.8	\$378

NOTES:

- Seat Shell is one-piece injection molded.
- Task Swivel Chair has a pneumatic seat height adjustment.
- Choose between hard and soft casters (no upcharge) or bell glide (\$25 upcharge) options.
- Stool has an adjustable footring.
- Swivel Task Chair and Stool ship one per carton.
- ! Swivel Task Chair and Stool are available with a black frame only.



LEARNING

HOW TO SPECIFY

<p>Select Model Number</p> <p>HSSTK-18B</p>	<p>Select Glide Option</p> <p>S Soft Caster (no upcharge) H Hard Caster (no upcharge) G Bell Glide (\$25 upcharge)</p> <p>S</p>	<p>Select Shell Color</p> <p>See page 801</p> <p>RG</p>
--	--	--

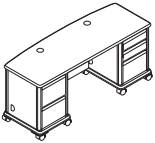

SMARTLINK® Teacher Stations

	DESCRIPTION	MODEL	SHIP WEIGHT	CUBE	LIST PRICE
	Teacher Station 72"W x 26"D x 30"H File/File Pedestal, Left Box/Box/File Pedestal, Right	HLT2672T-23	254	37.2	\$2145
	Teacher Station 60"W x 24"D x 30"H Box/Box/File Storage, Single Pedestal, Right Teacher Station 60"W x 24"D x 30"H Box/Box/File Storage, Single Pedestal, Left	HLT2460T-R3 HLT2460T-L3	136 136	29.3 29.3	\$1931 \$1931

NOTES:

- Tops/Bases are Laminate with T-mold edge.
- Larger top size provides ample work/conference area or space for equipment.
- Standard with Heavy-duty 3", 360-degree swivel casters, 4-locking, 4-non-locking.
- Storage options include: Locking box/box/file and locking file/file.
- Kneewell space accommodates separately specified and field installed non-locking center drawer and CPU holders (see page 817).
- End panels are removable to access standard power management cabinets on both ends of the station for safe and secure storage of plug-strips, power cords and cables.
- Removable end panels have one outside cord management grommet.
- Full width cable management system provides easy access to and from each side cabinet.
- Standard with two Smart Grommets with wireway covers.
- Smart Grommets accept optional power inserts (see page 817).
- Single pedestal available in right and left handed configurations.
- D-shape top encourages conferencing and provides ample work and conference area.
- Standard with modesty panel.
- Modesty and column leg will match the specified metal surface color.

HOW TO SPECIFY

Select Model Number H L T 2 6 7 2 T - 2 3 .	Select Casters C Hard-Surface (no upcharge) C .	Select Top and Base Color Laminate See page 801 B 9 .	Select T-Mold and Paint Color See page 801 T 1
---	--	---	---

	DESCRIPTION	MODEL	SHIP WEIGHT	CUBE	LIST PRICE
	Accessory Rail (Side Mount) 21"W x 1/2"D x 1 1/2"H	HLTA-TR24	3 Ⓞ	0.3	\$160

NOTES:

- Field installed.
- 21" Usable width.
- Specify paint.
- Mounts to either side of the Teacher Station or Storage Cases.
- Accepts file folder, CD/Pencil holder, or other accessories (see page 822).

HOW TO SPECIFY

Select Model Number H L T A - T R 2 4 .	Select Frame Color S Charcoal T1 Platinum (\$10 upcharge) S
---	---

LEARNING

SMARTLINK® Value Teacher Stations

GSA SIN 3372IT EXCEPT AS NOTED



Icon Legend on page 19

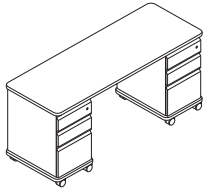

DESCRIPTION

Value Teacher Station
66"W x 24"D x 30"H
Box/Box/File Pedestal, Left
Box/Box/File Pedestal, Right

MODEL	SHIP WEIGHT	CUBE	LIST PRICE BY PAINT GRADE		
			P1	P2	P3
HLTV2466T-33	240	21.1	\$1795	\$1827	\$1848



Value Teacher Station
60"W x 24"D x 30"H
Box/Box/File Storage

HLTV2460T-3	158	14.18	\$1365	\$1391	\$1408
-------------	-----	-------	--------	--------	--------



NOTES:

- Tops/Bases are Laminate with T-mold edge.
- Standard with Heavy-duty 3", 360-degree swivel casters, 4-locking, 4-non-locking.
- Storage options include: Locking box/box/file.
- Kneewell space accommodates separately specified and field installed non-locking center drawer and CPU holders (see page 817).
- D-shape top encourages conferencing and provides ample work and conference area.
- Right or left assembled in the field.
- Modesty specified separately.
- Power modules can be ordered separately and mounted to the desk.

HOW TO SPECIFY

Select Model Number	Select Top and Base Color Laminate See page 801	Select T-Mold Color See page 801	Select Paint Color See page 801
H L T V 2 4 6 6 T - 3 3 .	B 9 .	K .	T 1

DESCRIPTION	MODEL	SHIP WEIGHT	CUBE	LIST PRICE BY PAINT GRADE		
				P1	P2	P3
Universal Modesty Panel	HMTUMOD32	9	1.9	\$206	\$226	\$237

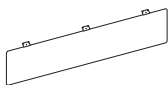

SIN 33721

HOW TO SPECIFY

Select Model Number	Select Paint Color See page 801
H M T U M O D 3 2 .	S



Icon Legend on page 19

SMARTLINK® Teacher Station Accessories



(Angled front)

DESCRIPTION

Metal Center Drawer, Non-Locking
24¾"W x 14¾"D x 3"H

MODEL	SHIP WEIGHT	CUBE	LIST PRICE BY PAINT GRADE	
			P1	P2
HD8X	12 Ⓞ	1.2	\$229	\$236

NOTES: Not for use on 24" x 60" Teacher's Stations. Field installed. Non-locking. Minimum clearance for mounting: 27¾"W x 19¼"D. Specify paint. Available in Charcoal (S) or Platinum (T1) \$10 upcharge.

SPECIFYING EXAMPLE: HD8X.S

DESCRIPTION

360° Swivel CPU Holder with Adjustable Straps

- Supports CPUs ¾" wide up to 64" perimeter and holds up to 75 lbs.
- 360° rotation.
- Ships complete and includes necessary mounting hardware and instruction sheet.

ⓘ Available in Black only, no specification needed.

MODEL	SHIP WEIGHT	CUBE	LIST PRICE
HCPU1	7.0 Ⓞ	0.2	\$243

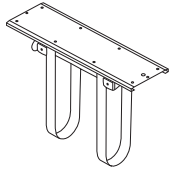

SIN 33721

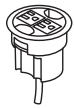

Power Hub, 3" Grommet Mount, 6' Cord

- Fits in 3" round grommet holes.
- Two grounded AC power outlets.
- Includes 6' cord with three-prong plug.
- Field installed with Plug-and-play ease.

NOTES: For additional information see page 848.

ⓘ Available in black only (no color designation so use .X - Specify: HGRMTAC.X).

MODEL	SHIP WEIGHT	CUBE	LIST PRICE
HGRMTAC	1.3	0.2	\$111

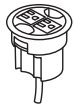

3" Round Power Grommet - 2 Outlets, 10' Cord

- Includes 10' cord with three-prong plug.
- Fits in 3" round grommet holes.
- Two grounded AC power outlets.
- Field installed with Plug-and-play ease.

ⓘ Available in black finish only, no specification needed.

MODEL	SHIP WEIGHT	CUBE	LIST PRICE
HGRMTAC2	1.5	0.2	\$148



Power/USB Hub, 3" Grommet Mount

- One grounded AC power outlet with 2 USB ports.
- Two cord pass-through holes in cap.
- Includes 6' cord with three-prong plug.
- Field installed; easy plug-and-play.
- UL Listed.

NOTES: For additional information see page 848.

ⓘ Available in black only (no color designation so use .X - Specify: HGRMTUSB2.X).

MODEL	SHIP WEIGHT	CUBE	LIST PRICE
HGRMTUSB2	1.3 Ⓞ	0.2	\$224

LEARNING

HOW TO SPECIFY

Select Model Number	Select Paint
	S Charcoal T1 Platinum (\$10 upcharge)
HD8X.	S

SMARTLINK® Modular Storage

GSA SIN 3372IT

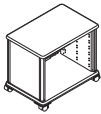
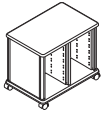

Icon Legend on page 19

	DESCRIPTION	MODEL	SHIP WEIGHT	CUBE	LIST PRICE
	Modular Storage Cabinet, Credenza Height 1 – 30"W Column 36¾"W x 24¼"D x 30"H	HLSC36T-1N	98	17.7	\$1222
	Modular Storage Cabinet, Credenza Height 2 – 12"W Columns 36¾"W x 24¼"D x 30"H	HLSC36T-2N	103	17.7	\$1337
	Modular Storage Cabinet, Credenza Height 1 – 30"W Left-hand Column 1 – 12"W Right-hand Column 52¾"W x 24¼"D x 30"H	HLSC52T-21N	154	25.3	\$1571
	Modular Storage Cabinet, Credenza Height 3 – 12"W Columns 52¾"W x 24¼"D x 30"H	HLSC52T-3N	159	25.3	\$1688
	Modular Storage Cabinet, Full Height 1 – 30"W Left-hand Column 1 – 12"W Right-hand Column 52¾"W x 24¼"D x 61¾"H	HLSF52T-21N	254	51.4	\$2130
	Modular Storage Cabinet, Full Height 3 – 12"W Columns 52¾"W x 24¼"D x 61¾"H	HLSF52T-3N	164	51.4	\$2359

LEARNING

NOTES:

- Cases will accept a variety of storage accessories including trays, shelves, and coat rods. Refer to pages 805-806 for capacity specification/planning guidelines by cabinet size.
- Specify trays, shelves, or coat rod accessories separately, see page 820.
- Standard with Heavy-duty 3", 360-degree swivel casters, 36" with case includes four casters (2-locking, 2-non-locking), 52"W cases include six casters (3-locking, 3-non-locking).

HOW TO SPECIFY

Select Model Number HLSC36T-1N	Select Casters C Hard-Surface (no upcharge)	Select Top and Base Color Laminate See page 801 DD	Select T-Mold and Paint Color See page 801 T1
--	---	--	--



Icon Legend on page 19

SMARTLINK® Modular Storage

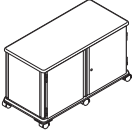
	DESCRIPTION	MODEL	SHIP WEIGHT	CUBE	LIST PRICE
	Modular Storage Cabinet, Credenza Height 1 – 30”W Column 36¾”W x 24¼”D x 30”H	HLSC36T-1D	114	17.7	\$1383
	Modular Storage Cabinet, Credenza Height 2 – 12”W Columns 36¾”W x 24¼”D x 30”H	HLSC36T-2D	119	17.7	\$1492
	Modular Storage Cabinet, Credenza Height 1 – 30”W Left-hand Column 1 – 12”W Right-hand Column 52¾”W x 24¼”D x 30”H	HLSC52T-21D	174	25.3	\$1690
	Modular Storage Cabinet, Credenza Height 3 – 12”W Columns 52¾”W x 24¼”D x 30”H	HLSC52T-3D	179	25.3	\$1798
	Modular Storage Cabinet, Full Height 1 – 30”W Left-hand Column 1 – 12”W Right-hand Column 52¾”W x 24¼”D x 61¾”H	HLSF52T-21D	286	51.4	\$2280
	Modular Storage Cabinet, Full Height 3 – 12”W Columns 52¾”W x 24¼”D x 61¾”H	HLSF52T-3D	296	51.4	\$2491

LEARNING

NOTES:

- Cases will accept a variety of storage accessories including trays, shelves, and coat rods. Refer to pages 805-806 for capacity specification/planning guidelines by cabinet size.
- Specify trays, shelves, or coat rod accessories separately, see page 820.
- Standard with Heavy-duty 3”, 360-degree swivel casters, 36” with case includes four casters (2-locking, 2-non-locking), 52”W cases include six casters (3-locking, 3-non-locking).

HOW TO SPECIFY

<p>Select Model Number</p> <p>HLSC36T-1D</p>	<p>Select Casters</p> <p>C Hard-Surface (no upcharge)</p> <p>C</p>	<p>Select Top and Base Color</p> <p>Laminate</p> <p>See page 801</p> <p>DD</p>	<p>Select T-Mold and Paint Color</p> <p>See page 801</p> <p>T1</p>
---	---	---	---

SMARTLINK® Modular Storage and Accessories

GSA SIN 3372IT



Icon Legend on page 19

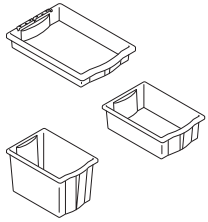

DESCRIPTION

Tray Kits

3"H x 12"W, 7 trays and 14 rails per kit
6"H x 12"W, 4 trays and 8 rails per kit
12"H x 12"W, 2 trays and 4 rails per kit

NOTES: Field installed. See pages 805-806 for specifying guidelines.

! Semi-translucent white

SPECIFYING EXAMPLE: HLSA-TK3.X

MODEL

SHIP WEIGHT

CUBE

LIST PRICE

HLSA-TK3
HLSA-TK6
HLSA-TK12

12.0 **Ⓔ**
10.0 **Ⓔ**
7.0 **Ⓔ**

2.7
2.7
2.7

\$195
\$134
\$101

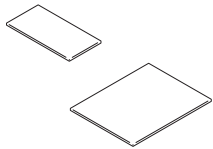

Shelf Kits, 2 shelves and 4 rails per kit

12"W x 24"D
30"W x 24"D

NOTES: Field installed. See pages 805-806 for specifying guidelines. Specify color.

HLSA-SK1220T
HLSA-SK3020T

14.0 **Ⓔ**
28.0 **Ⓔ**

0.6
1.2

\$285
\$414



Coat Rod, Single Unit

12"W x 1" diameter

NOTES: Use with Full-height cases, 12" columns only. Field installed.

! Anodized finish only.

HLSA-CR12

0.5 **Ⓔ**

0.1

\$99

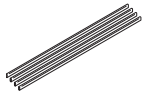

Hanging Folder Rail Kit

12"W Rails
4 rails per kit, each tray uses 2 rails

NOTES: Use with 12" trays only. Field installed.

! Anodized finish only.

HLSA-HRK

0.5 **Ⓔ**

0.2

\$40

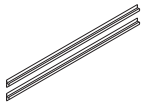

Cabinet Mounting Bracket

52"W

Includes 1 pair (upper and lower) of rails and mounting hardware.

- Accommodates: 1 – 48" x 48" Sliding Board or
2 – 24" x 48" Sliding Boards

- Compatible Sliding Boards (see page 821)

HLWBS-448WW
HLWBS-248WW
HLWBS-448WT
HLWBS-248WT

- Requires field installation.

NOTES: For use on full-height cabinets only. Rails feature an integrated marker tray. **Specify Charcoal (S) or Platinum (T1) color.**

SPECIFYING EXAMPLE: HLSA-WBK52.S

HLSA-WBK52

5.0 **Ⓔ**

0.3

\$179

NOTES:

- Mounting bracket model HLSA-WBK52 mounts to back of full-height Modular Storage unit.
- For use in Modular Storage cases.
- Trays for use in 12" width columns only. Shelves are available for use in 12" and 30" width columns.
- Trays and shelves hang off a pair of accessory rails.
- Trays and shelves are sold in "kit quantities" and include necessary accessory rails for installation.
- 12" trays accept rails to accommodate hanging file folders (side-to-side).
- All accessories are field installed.
- Trays feature front and rear handles for easy handling and are semi-translucent white for visibility to contents.
- All shelves feature an integrated finger pull and safety mechanism to prevent accidental removal.
- See pages 805-806 for specifying details.

HOW TO SPECIFY

Select
Model Number

Select
Shelf Color

- C** Harvest
- D** Natural Maple
- LDW1** Designer White
- LOFT** Loft

H L S A - S K 1 2 2 0 T .

C

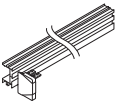
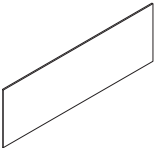
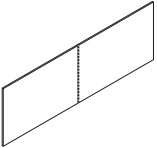
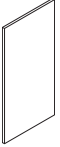
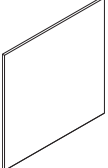

SMARTLINK® Wall Rail System

	DESCRIPTION	MODEL	SHIP WEIGHT	CUBE	LIST PRICE
	Wall Rail 144" NOTES: Rail model includes: 1 – 144" rail, 9 – wall mounting brackets and 2 – rail end caps. ! Must be mounted in accordance with published installation instructions. Wall mounting hardware NOT INCLUDED. Must be sourced locally. ! Must order Quantity 2 rails when using with and /. ! Platinum finish only.	HLWR-12	22	1.4	\$759
	Learning Board, Fixed , 1-sided 144"W x 48' 'H, Quantity 1 SPECIFYING EXAMPLE: HLWBF1-1248W.X	HLWBF1-1248W	124	13.0	\$1813
	Learning Board, Fixed , 1-sided 72"W x 48"H, Quantity 2 with spacer (included) NOTES: Includes center cover/spacer. SPECIFYING EXAMPLE: HLWBF2-1248W.X	HLWBF2-1248W	125	6.7	\$1813
	Learning Board, Sliding 48"W x 48"H 24"W x 48"H NOTES: May be used with HLSA-WBK52 to mount to the back of full-height Mobile Cabinets. (See page 820.) SPECIFYING EXAMPLE: HLWBS-448WW.X	HLWBS-448WW HLWBS-248WW	47 26	4.6 2.5	\$874 \$558
<i>Model HLWBS-248WW shown</i>					
	Learning Board, Sliding / 48"W x 48"H 24"W x 48"H NOTES: May be used with HLSA-WBK52 to mount to the back of full-height Mobile Cabinets. (See page 820.) Side available in the following fabric: Lucy Neutra (LC24). SPECIFYING EXAMPLE: HLWBS-448WT.X.LC24	HLWBS-448WT HLWBS-248WT	64 34	4.6 2.5	\$909 \$582
<i>Model HLWBS-448WT shown</i>					

LEARNING

NOTES:

- Multi-functional wall rails can accommodate , worksurfaces and organizational accessories. See above and page 822.
- Sliding learning boards may be attached to the back of Mobile, full-height cabinets with bracket kit HLSA-WBK52 (see page 820).
- Multi-track rail allows for up to three layers of . Rear track supports a fixed board, middle and front tracks support sliding boards. Outer rail channel is for attachment of worksurfaces and organizational accessories.
- Sliding learning boards are removable and reversible.
- All fixed and sliding boards:
 - Require two (upper and lower) rails for installation.
 - Feature a full aluminum frame.
 - Are high quality porcelain over steel and non-shadowing.
 - Are low gloss for projection use and allows for use of magnets.

HOW TO SPECIFY











<p>Select Model Number</p> <p>HLWBS - 448WT .</p>	<p>Select Side A Color</p> <p>X .</p>	<p>Select Fabric</p> <p>LC24 Lucy Neutra Specify for models HLWBS-448WT and HLWBS-248WT only</p> <p>LC24</p>
--	--	---

SMARTLINK® Wall Rail System Accessories

GSA SIN 3372IT EXCEPT AS NOTED



Icon Legend on page 19

	DESCRIPTION	MODEL	SHIP WEIGHT	CUBE	LIST PRICE BY PAINT GRADE		
					P1	P2	P3
	Marker Tray (Single Pack) 7"W x 3½"D x 2"H NOTES: Holds dry-erase markers, push pins and other small objects.	HPPMMT	1 	0.2	\$88	\$100	\$111
	Paper Clip (2 per carton) 5"W x 2"H NOTES: Use individually for artwork or smaller items. Use in pairs for larger notepad size pieces of paper.	HPPMPC	1 	0.2	\$91	\$103	\$114
	All-Purpose Hook (10 per carton) NOTES: Use for hanging back-packs, coats and other items. Hooks slide horizontally and cannot be removed without first removing the rail end cap.  Specify paint — Platinum Metallic only.	HPPMHK	1 	0.2	N/A	\$204	N/A
 SIN 33721	CD/Pencil Holder 5¼"W x 1½"D x 5"H NOTES: Installs on the Wall Rail or Accessory Rail (HLTA-TR24) for use on the Teacher's Desk or Storage Cases. May also be mounted on Folder Bins.	HPPMPB	1 	0.2	\$101	\$113	\$124
 SIN 33721	Folder Bin 12¼"W x 1¼"D x 9"H NOTES: Installs on the Wall Rail or Accessory Rail (HLTA-TR24) for use on the Teacher's Desk or Storage Cases. Folder Bin may be mounted (stacked) to each other.	HPPMFB	2 	0.3	\$101	\$113	\$124

NOTES:

- Accessories above to be used on the Wall Rail System — see page 821.
- All accessories mount on the rail's outer channel and may be used with sliding boards.
- All accessories may be mounted and moved to any position along the width of the rail.
- All accessories may be easily removed from the rail with the exception of the All-Purpose Hook. All-Purpose Hook can slide horizontally along the rail but cannot be removed without removing a rail end cap.

HOW TO SPECIFY

<p>Select Model Number</p> <p>H P P M M T .</p>	<p>Select Paint Color</p> <p>See page 801 Model HPPMHK available in Platinum Metallic only</p> <p>T 1</p>
--	--

WORKPLACE TOOLS



Coordinate™ Height-Adjustable Base, Monitor Arms and Task Light shown with Nucleus® Seating and Abound® Panels.

WORKPLACE TOOLS

Workplace tools provide the finishing touch on any high-performance workspace. From storage options to technological tools and lighting solutions, HON's Workplace Tools deliver organization and efficiency to the office. Workplace Tools put everything you need to be productive within arm's reach, provide easy access to the connectivity you need to be successful and help you keep your workspace neat.



FEATURES

- HON keyboard trays and center drawers make the most of your valuable desk space.
- Create additional opportunities for organization with paper management and organizational tools.
- Bring power and data directly to the worksurface and cleanly route cables and cords out of your way with power and cable management solutions.
- Task lighting designed to illuminate any work area and give you more control over your environment.

KEYBOARD TRAYS & CENTER DRAWERS ORDERING INFORMATION

LAMINATE CENTER DRAWERS, LAMINATE PAPER MANAGEMENT MODELS HLVP1/HLDST1/ HLSL1472LS/HLSL1460LS

L1 LAMINATES	CODES
Woodgrain	
◆ Bourbon Cherry	H
◆ Cognac	COGN
◆ Florence Walnut	LFW1
◆ Harvest	C
◆ Kingswood Walnut	LK11
◆ Mahogany	N
◆ Mocha	MOCH
◆ Natural Maple	D
◆ Pinnacle	PINC
◆ Shaker Cherry	F
Solid	
◆ Black	P
◆ Charcoal	S
◆ Designer White	LDW1
◆ Loft	LOFT
L2 LAMINATES	CODES
Woodgrain	
◆ Lowell Ash	LLA1
◆ Natural Recon	LNR1
◆ Phantom Ecru	LPE1
◆ Portico Teak	LPT1
◆ Skyline Walnut	LSW1

LAMINATE KEYBOARD PLATFORM MODELS H4022/HE4022

L1 LAMINATES	CODES
Woodgrain	
◆ Bourbon Cherry	H
◆ Cognac	COGN
◆ Florence Walnut	LFW1
◆ Harvest	C
◆ Kingswood Walnut	LK11
◆ Mahogany	N
◆ Mocha	MOCH
◆ Natural Maple	D
◆ Pinnacle	PINC
◆ Shaker Cherry	F
Solid	
◆ Black	P
◆ Charcoal	S
◆ Designer White	LDW1
◆ Whitestone	K4
Patterned	
◆ Sheer Mesh	A5
◆ Silver Mesh	B9
◆ Steel Mesh	A9
◆ Canyon Zephyr	K9
◆ Desert Zephyr	K8
◆ Shadow Zephyr	K1
◆ Gray	G2
◆ Grey Tigris	L6
◆ White	G1
L2 LAMINATES	CODES
Woodgrain	
◆ Lowell Ash	LLA1
◆ Natural Recon	LNR1
◆ Phantom Ecru	LPE1
◆ Portico Teak	LPT1
◆ Skyline Walnut	LSW1

METAL PAPER MANAGEMENT MODELS HHPS1 AND HDPS1

PAINT	CODES
P1	
◆ Black	P
◆ Brownstone	P7D
◆ Charcoal	S
◆ Designer White	PJW
◆ Fossil	P28
◆ Loft	LOFT
◆ Muslin	T3
◆ Titanium	P8T
P2	
◆ Champagne Metallic	T4
◆ Platinum Metallic	T1
◆ Silver	PR6
P3	
◆ Atom	P8S
◆ Bullseye	PJF
◆ Ember	P8P
◆ Ion	P8N
◆ Iris	P8J
◆ Krypton	P8F
◆ Regatta	P8M

METAL CENTER DRAWERS*, CORNER SLEEVES, METAL KEYBOARD PLATFORM, STORAGE CUBES, DRAWER ORGANIZER

PAINT	CODES
P1	
◆ Black	P
◆ Brownstone	P7D
◆ Charcoal	S
◆ Designer White	PJW
◆ Fossil	P28
◆ Greige	T5
◆ Light Gray	Q
◆ Loft	LOFT
◆ Muslin	T3
◆ Putty	L
◆ Shadow	SHDW
◆ Titanium	P8T
P2	
◆ Champagne Metallic	T4
◆ Platinum Metallic	T1
◆ Silver	PR6
◆ Solar Black	P8X
P3	
◆ Atom	P8S
◆ Bullseye	PJF
◆ Ember	P8P
◆ Ion	P8N
◆ Iris	P8J
◆ Krypton	P8F
◆ Regatta	P8M

* Models HD2 and HD8 limited to P1 Paints, Champagne Metallic, and Platinum Metallic.

◆◆◆ For lead time information see page 19.

* De-emphasized

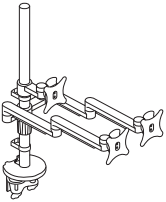
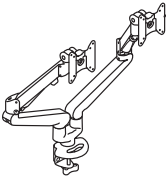
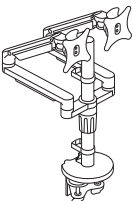
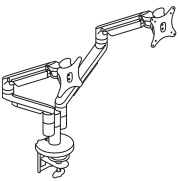
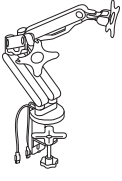

MONITOR ARMS

	DESCRIPTION	MODEL	SHIP WEIGHT	CUBE	LIST PRICE
	<p>Post Mount with Triple Fixed Arms</p> <ul style="list-style-type: none"> • Features two fixed extended arms and one fixed center mount. • Arms have 180° of rotation at base with optional 360° rotation. • Monitor mount rotates 180° and tilts +/-30°. • Monitor can be rotated from landscape to portrait position. • Arms extend up to 20". • Arms have 27½" of vertical adjustment. <p>ⓘ Available in Silver (SVR) finish only.</p> <p>ⓘ Arms hold monitors from 6.2-18 lbs. Optional counterweight HPACW available to support monitors as low as 5 lbs. (see page 827).</p>	HPATF	22.0 Ⓢ	1.9	\$1140
	<p>Dual Monitor Arm — Effortless Adjustment</p> <ul style="list-style-type: none"> • Single mount with dual monitor adjustment. • Effortless adjustment. • Height adjusts from 7" to 20" for a total range of 13". • Monitor extends 22½". • Monitor retracts 3½" to save space. • 360° swivel at two points with folding capabilities. • Monitor tilts +25° to -90°. • Enclosed cable management. • Dual screen models allow screens to be aligned horizontally for optimal ergonomic positioning. • Includes desk clamp or grommet mount. • Includes VESA plate for 75 x 75mm or 100 x 100mm (converter plate for 100mm x 200mm is available separately). <p>ⓘ Silver finish only, no specification needed.</p>	H5220 *	15.0 Ⓢ	1.8	\$996
	<p>Post Mount with Dual Dynamic Arms</p> <ul style="list-style-type: none"> • Arms have 180° of rotation at base with optional 360° rotation. • Monitor mount rotates 180° and tilts +/-30°. • Monitor can be rotated from landscape to portrait position. • Arms extend up to 20". • Arms have 17¾" of vertical adjustment. <p>ⓘ Available in Silver (SVR) finish only.</p> <p>ⓘ Arms hold monitors from 6.2-18 lbs. Optional counterweight HPACW available to support monitors as low as 5 lbs. (see page 827).</p>	HPADD	19.5 Ⓢ	1.3	\$996
	<p>Dual Dynamic Monitor Arm</p> <ul style="list-style-type: none"> • 150° of rotation at base with optional 360° rotation. • Arms extend 22" and retract up to 3". • Monitor mount rotates 180° and tilts +/-30°. • Monitor can be rotated from landscape to portrait position. <p>ⓘ Arms hold monitors from 6.2-18 lbs. Optional counterweight HPACW available to support monitors as low as 5 lbs. (see page 827).</p>	HMASD	17.0 Ⓢ	1.1	\$750
	<p>Dual Monitor Arm with 2 USB Ports</p> <p>NOTES: Easy adjustment. Height adjusts to 17" tall. Monitor tilt and swivel capability. Enclosed cable management. Grommet or desktop mounting. Clean appearance. In some applications the Monitor Arms may extend 12 or more inches into the worksurface. HON 5-Year Limited Warranty.</p> <p>ⓘ No specification needed.</p> <p>ⓘ Cannot be used in Empower® height adjustable applications.</p>	HBDMAUSB	41.9	2.6	\$441

NOTES:

* De-emphasized.

HOW TO SPECIFY

<p>Select Model Number</p> <p>H 5 2 2 0 .</p>	<p>Select Finish</p> <p>Specify for model HMASD only</p> <p>SVR Silver BLK Black</p> <p>SVR</p>
--	---

MONITOR ARMS

DESCRIPTION

MODEL

SHIP WEIGHT

CUBE

LIST PRICE

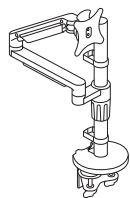

Post Mount with Single Dynamic Arm

- Arm has 180° of rotation at base with optional 360° rotation.
- Monitor mount rotates 180° and tilts +/-30°.
- Monitor can be rotated from landscape to portrait position.
- Arm extends up to 20”.
- Arm has 17¾” of vertical adjustment.

ⓘ Available in Silver (SVR) finish only.

ⓘ Arms hold monitors from 6.2-18 lbs. Optional counterweight HPACW available to support monitors as low as 5 lbs. (see page 827).

HPASD

15.5 Ⓢ

1.3

\$684

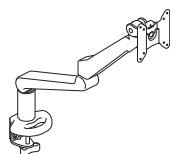

Single Monitor Arm — Effortless Adjustment

- Effortless adjustment.
- Height adjusts from 7” to 20” for a total range of 13”.
- Monitor extends 22½”.
- Monitor retracts 3½” to save space.
- 360° swivel at two points with folding capabilities.
- Monitor tilts +25° to -90°.
- Enclosed cable management.
- Includes desk clamp or grommet mount.

ⓘ Silver finish only, no specification needed.

H5210 *

11.0 Ⓢ

1.3

\$557

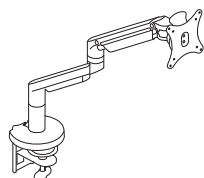

Single Dynamic Monitor Arm

- 180° of rotation at base with optional 360° rotation.
- Arms extend 22” and retract up to 3”.
- Monitor mount rotates 180° and tilts +/-30°.
- Monitor can be rotated from landscape to portrait position.

ⓘ Arms hold monitors from 6.2-18 lbs. Optional counterweight HPACW available to support monitors as low as 5 lbs. (see page 827).

HMASTS

11.5 Ⓢ

0.8

\$468

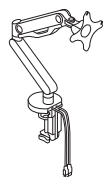

Single Monitor Arm with 2 USB Ports

NOTES: Easy adjustment. Height adjusts to 17” tall. Monitor tilt and swivel capability. Enclosed cable management. Grommet or desktop mounting. Clean appearance. **HON 5-Year Limited Warranty.**

ⓘ No specification needed.

ⓘ Cannot be used in Empower® height adjustable applications.

HBSMAUSB

38.6

2.4

\$294

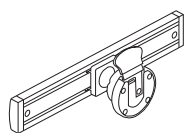

Sliding Mount for Monitor Arm

- Supports monitors up to 18 lbs.
- Compatible with VESA 75mm and 100mm mounts.
- Compatible with models HMASTS, HMASD, HPASD, HPADD, and HPATF.
- Available in two paint finishes, Silver (SVR) and Black (BLK). Plastic components ship in like color with specified paint finish.

HPACSM

3.0 Ⓢ

0.3

\$192

NOTES:

* De-emphasized.

HOW TO SPECIFY

<p>Select Model Number</p>	<p>Select Finish</p> <p><i>Specify for models HMASTS and HPACSM only</i></p> <p>SVR Silver BLK Black</p>
<p>HPASD.</p>	<p>SVR</p>

MONITOR ARM ACCESSORIES & CPU HOLDER

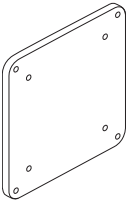
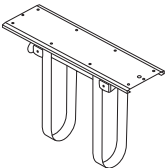
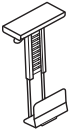
	DESCRIPTION	MODEL	SHIP WEIGHT	CUBE	LIST PRICE
	<p>Monitor Arm Counterweight</p> <ul style="list-style-type: none"> Optional counterweight for monitors as low as 5 lbs. Minimum weight for monitors without counterweight is 6.2 lbs. <p>! Available in Black only, no specification needed.</p> <p>! Compatible with models HMASTS, HPASD, HMASD, HPADD, and HPATF.</p>	HPACW	3 ⑥	0.1	\$22
	<p>360° Swivel CPU Holder with Adjustable Straps</p> <ul style="list-style-type: none"> Supports CPUs 3³/₄" wide up to 64" perimeter and holds up to 75 lbs. 360° rotation. Ships complete and includes necessary mounting hardware and instruction sheet. <p>! Available in Black only, no specification needed.</p>	HCPU1	7 ⑥	0.2	\$243
 OPEN MARKET	<p>CPU Holder</p> <ul style="list-style-type: none"> Vertically mounts to underside of worksurface. 360° swivel. Supports up to 55 lbs. Height adjustable from 16" to 22" below worksurface. Width adjustable to accept units from 3¹/₄" to 6". <p>! Silver finish only, no specification needed.</p>	HCPU ⑥	16 ⑥	0.5	\$259

NOTES:







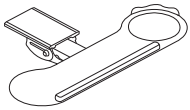

* De-emphasized.

HOW TO SPECIFY

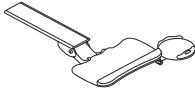
Select
Model Number

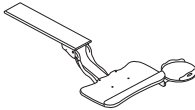
H P A C W

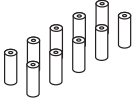
KEYBOARD TRAYS

	DESCRIPTION	MODEL	SHIP WEIGHT	CUBE	LIST PRICE
	Short Track and Keyboard Platform <ul style="list-style-type: none"> Height adjustable total of 5$\frac{3}{4}$" (1$\frac{3}{4}$" above and 4" below). +10°, -20° of tilt adjustment. 360° rotation. 	HKTSHORT	10 	0.8	\$541
	Mid Track with Keyboard and Mouse Platform <ul style="list-style-type: none"> Height adjustable total of 8" (3" above and 5" below). +10°, -20° of tilt adjustment. 360° rotation. 	HKT MID	17 	1.2	\$518
	Sit to Stand Long Track with Keyboard and Mouse <ul style="list-style-type: none"> Height adjustable total of 12$\frac{1}{2}$" (7$\frac{1}{2}$" above and 5" below). +10°, -20° of tilt adjustment. 360° rotation. 	HKT LONG	17 	0.8	\$581
	Keyboard Spacer <ul style="list-style-type: none"> Used when attaching HKT MID or HKT LONG to Coordinate™ and Voi® or Systems Worksurface with an external channel. The kit includes ten cylinder spacers and ten screws. Spacers are $\frac{3}{4}$"W x 2$\frac{1}{8}$"H. Specify one kit per keyboard tray. 	HKBS	1 	0.8	\$90

HOW TO SPECIFY

Select
Model Number

H K T M I D

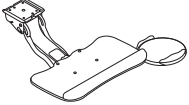
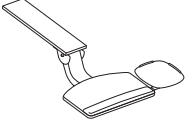
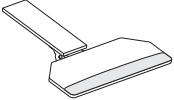
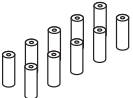

KEYBOARD TRAYS

	DESCRIPTION	MODEL	SHIP WEIGHT	CUBE	LIST PRICE
	<p>Sit to Stand Arm with Keyboard</p> <ul style="list-style-type: none"> • Sit to stand application. • No knob or lever for adjustment, simply lift into place. • One-hand tilt adjustment for maximum flexibility. • For use on surfaces 24" or deeper. • Height adjustment without levers. • +10°/-20° tilt adjustment. • Height adjustment 12½" (7" above and 5½" below). • Tilt and swivel mouse surface with gel palm rest. • Detachable palm rest. • Mouse pad can mount right or left. <p>! Black finish only, no specification needed.</p>	H2516 *	17 Ⓔ	1.6	\$618
	<p>Articulating Arm with Convertible Keyboard</p> <ul style="list-style-type: none"> • 21" glide track. • Lift and lock height adjustment. • Height adjustment 7" (2½" above and 4½" below track). • Release handle for independent tilt adjustment. • Tilt: +/-15°. • Independent tilt and swivel mousing platform. • Positions platform flush with worksurface. • 360° rotation. • Mouse can be used in-line, over, or forward at platform height or above. • Mouse can be placed at platform height or above height. • Left or right handed mousing; no tools required. • Detachable palm rest. • Cord management clips included. <p>! Black finish only, no specification needed.</p>	H2107 *	16 Ⓔ	1.3	\$529
	<p>Articulating Arm with Keyboard</p> <ul style="list-style-type: none"> • 17" glide track. • Spring assisted. • Height adjustment 6¼" (1¼" above and 5" below track). • Tilt: +10°/-15°. • 25" cut corner platform. • Accommodates keyboard and mouse on same level. • Detachable palm rest. • Cord management clips included. <p>! Black finish only, no specification needed.</p>	H1706 *	16 Ⓔ	1.4	\$493
	<p>Keyboard Spacer</p> <ul style="list-style-type: none"> • For use when attaching a keyboard tray to Coordinate™ and Voi® or Systems Worksurface with an external channel. • The kit includes ten cylinder spacers and ten screws. • Spacers are ¾"W x 2⅛"H. • Specify one kit per keyboard tray. 	HKBS	1 Ⓔ	0.8	\$90

NOTES:

* De-emphasized.

HOW TO SPECIFY

Select Model Number

H 2 5 1 6



Icon Legend on page 19

KEYBOARD TRAYS

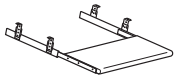

DESCRIPTION

Laminate Keyboard Platform

- Laminate Tray dimensions: 21½"W x 10"D x 1⅛" Thick.
- Minimum clearance for mounting: 22⅞"W x 17"D.
- Surface can be positioned 2", 2½", 3" or 3½" below bottom of worksurface.
- Will not fit on a 37" x 24" Corner worksurface.
- Specify laminate.

MODEL	SHIP WEIGHT	CUBE	LIST PRICE
H4022	10 Ⓞ	0.6	\$213

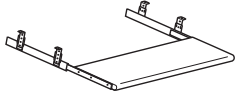

Laminate Keyboard Platform with Extended Tray

- Laminate Tray dimensions: 30"W x 10"D x 1⅛" Thick.
- Minimum clearance for mounting: 32½"W x 17"D.
- Surface can be positioned 2", 2½", 3" or 3½" below bottom of worksurface.
- Will not fit on a 37" x 24" Corner worksurface.
- Ball-bearing slide; slide and brackets are Black.

HE4022	12 Ⓞ	0.7	\$302
--------	------	-----	-------

HOW TO SPECIFY

Select Model Number H 4 0 2 2 .	Select Laminate See page 824 H
---	---

DESCRIPTION

Metal Keyboard Platforms

30"W Metal Keyboard and Mouse Tray

- Designed to hold keyboards and allow room for mouse pads.
- Tray dimensions: 30"W x 10"D.
- Minimum clearance for mounting: 32½"W x 15"D.
- Surface is positioned 3" below bottom of worksurface.
- Non-articulating, only movement is front-to-back. Does not tilt or swivel.
- Specify paint color.

MODEL	SHIP WEIGHT	CUBE	LIST PRICE BY PAINT GRADE PT
H4028	11 Ⓞ	1.5	\$153

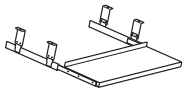

OPEN MARKET

24"W Metal Keyboard Tray

- Designed to hold ONLY keyboards.
- Tray dimensions: 24"W x 10"D.
- Minimum clearance for mounting: 26½"W x 15"D.
- Surface is positioned 3" below bottom of worksurface.
- Non-articulating, only movement is front-to-back. Does not tilt or swivel.
- Specify paint color.

H4029	11 Ⓞ	1.5	\$138
-------	------	-----	-------

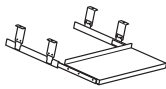

OPEN MARKET

HOW TO SPECIFY

Select Model Number H 4 0 2 8 .	Select Paint Color See page 824 T 1
---	--

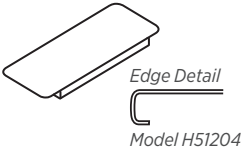
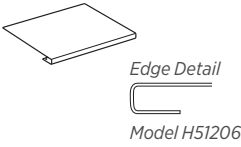

CORNER SLEEVES

	DESCRIPTION	MODEL	SHIP WEIGHT	CUBE	LIST PRICE BY PAINT GRADE		
					P1	P2	P3
 <p>Edge Detail Model H51204</p>	<p>Metal Corner Sleeves</p> <p>22½"W Leading Edge x 9"D</p> <ul style="list-style-type: none"> Fits 1⅝" thick square edge detail. Smaller design is more aesthetically pleasing. 	H51204	10 Ⓔ	1.5	\$155	\$162	\$172
 <p>Edge Detail Model H51206</p>	<p>22½"W Leading Edge x 18"D</p> <ul style="list-style-type: none"> Fits 1⅝" thick square edge detail. 	H51206	10 Ⓔ	1.5	\$155	\$165	\$172

NOTES:

- Corner sleeve connects intersecting worksurfaces to create "corner desk" work areas.
- Specify paint color.

HOW TO SPECIFY

<p>Select Model Number</p> <p>H 5 1 2 0 4 . P</p>	<p>Select Paint Color</p> <p>See page 824</p>
---	---

CENTER DRAWERS

ABI

Icon Legend on page 19

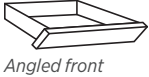

DESCRIPTION	MODEL	SHIP WEIGHT	CUBE	L1 LIST PRICE	L2 LIST PRICE
Laminate Center Drawer 22"W x 15 ³ / ₈ "D x 2 ¹ / ₂ "H Specify laminate.	H1522	11 Ⓔ	1.1	\$184	\$199
26"W x 15 ³ / ₈ "D x 2 ¹ / ₂ "H Specify laminate. <ul style="list-style-type: none"> • Ball-bearing slide suspension. • 12" drawer extension (3/4). • Inside drawer dimension for H1522: 18⁷/₈"W x 15¹/₂"D x 1¹/₂"H. • Inside drawer dimension for H1526: 22³/₄"W x 15¹/₂"D x 1¹/₂"H. • Minimum clearance for mounting H1522: 22³/₄"W x 18¹/₂"D compatible with 72"W x 36"D, 66"W x 30"D, 60"W x 30"D Double Pedestal Desks, 72"W x 36"D, 66"W x 30"D Single Pedestal Desks, Bullet and P-Shaped Peninsulas, 72"W x 24"D, 66"W x 24"D, 60"W x 24"D Credenza w/Kneespace, 72"W x 24"D, 66"W x 24"D Single Pedestal Credenzas, 48"W x 24"D, 42"W x 24"D Returns • Minimum clearance for mounting H1526: 27¹/₄"W x 18¹/₂"D compatible with 72"W x 36"D, 66"W x 30"D, 60"W x 30"D Double Pedestal Desks, 72"W x 24"D, 66"W x 24"D, 60"W x 24"D Credenza w/Kneespace, 48"W x 24"D Return • Designed for use with Concinnity™, Voi®, Valido®/11500, 10700 and 10500 Series™. • Includes pencil tray. 	H1526	12 Ⓔ	1.2	\$198	\$213

NOTES: For 60"W x 30"D Modular Desk Shells with two 15⁵/₈"W Storage Pedestals or 60"W x 24"D Modular Credenza Shells with two 15⁵/₈"W Storage Pedestals, use center drawer H1522.

HOW TO SPECIFY

Select
Model Number

Select
Laminate

See page 824









H 1 5 2 2 .

H

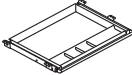

Icon Legend on page 19

CENTER DRAWERS

	DESCRIPTION	MODEL	SHIP WEIGHT	CUBE	LIST PRICE BY PAINT GRADE		
					P1	P2	P3
 Angled front 	Metal Center Drawer w/Lock 19"W x 14 ³ / ₄ "D x 3"H Specify paint color. <ul style="list-style-type: none"> • Ball-bearing slide suspension. • 12" drawer extension (3/4). • Inside drawer dimension: 19"W x 13"D x 2³/₈"H. • Minimum clearance for mounting: 21³/₄"W x 19¹/₄"D. • Core removable lock. 	HD2	9 	1.0	\$257	\$267	\$275
 Angled front 	24 ³ / ₄ "W x 14 ³ / ₄ "D x 3"H Specify paint color. <ul style="list-style-type: none"> • Ball-bearing slide suspension. • 12" drawer extension (3/4). • Inside drawer dimension: 24¹/₂"W x 13"D x 2³/₈"H. • Minimum clearance for mounting: 27³/₈"W x 19¹/₄"D. • Core removable lock. 	HD8	12 	1.2	\$257	\$267	\$275
 OPEN MARKET	Polymer Center Drawer <ul style="list-style-type: none"> • Color: Black. • Material: ABS. • Minimum clearance for mounting: 23"W x 16¹/₄"D x 2"H. • Retracts on 16" ball-bearing slides. • Can be used on worksurfaces with Coordinate™ Height Adjustable Bases as long as it is attached with spacer model HKBS. • Can store up to 25 lbs. <p> Black finish only, no specification needed.</p>	HCD1		7		0.5	\$108

NOTES:

- All metal center drawers feature pencil trays with three compartments for storage.
- All metal center drawers feature core removable locks for greater personal and departmental security.

HOW TO SPECIFY

Select Model Number HD2.	Select Paint Color See page 824 T1
-----------------------------	--

COORDINATE™ Height Adjustable Bases

OPEN MARKET



Icon Legend on page 19

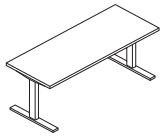

Base shown with work surface attached.

DESCRIPTION

Height Adjustable Base – 2 Stage

24”D Feet and Worksurface Brackets

MODEL

HHAB2S2L

SHIP WEIGHT

63

CUBE

2.4

LIST PRICE

\$1006

NOTES: Base is a dual motor 2-stage design. Legs raise from 25⁵/₈” to 45¹/₄”. Base telescopes to accommodate any rectangular work surface between 24”D x 42”W and 30”D x 72”W. Supports weight capacity of 250 lbs. (excluding work surface weight). See page 718 for Voi® Worksurfaces. See page 718 for Systems Worksurfaces. For Height Adjustable Base Accessories see page 716. Foundation™, Systems, Voi®, 10500, and Preside® all have work surfaces within this range.

⚠ When attaching a Keyboard Tray, remember to also specify a Keyboard Spacer Kit (HKBS).

⚠ Telescoping horizontal frame will extend just over 2” from underside of the work surface.

SPECIFYING EXAMPLE: HHAB2S2L.P8L

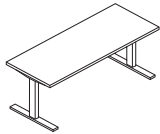

Base shown with work surface attached.

Height Adjustable Base – 3 Stage

24”D Feet and Worksurface Brackets

HHAB3S2L

67

2.4

\$1120

NOTES: Base is a dual motor 3-stage design. Legs raise from 21⁵/₈” to 47³/₄”. Base telescopes to accommodate any rectangular work surface between 24”D x 42”W and 30”D x 72”W. Supports weight capacity of 250 lbs. (excluding work surface weight). Foundation™, Systems, Voi®, 10500, and Preside® all have work surfaces within this range.

⚠ Telescoping horizontal frame will extend just over 2” from underside of the work surface.

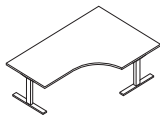

Base shown with work surface attached.

3-Leg Height Adjustable Base – 3 Stage

24”D Feet and Worksurface Brackets

HHAB3S3L

91

3.6

\$1896

NOTES: Base is a three motor 3-stage design. Legs raise from 21⁵/₈” to 47³/₄”. **The 3-leg base supports corner covers or two-piece work surfaces 41”-72”W x 35”-72”L x 23³/₄”-30”D. 48”W 120 degree corner work surfaces are also supported. When using two work surfaces, the connection between the two must be over the telescoping frame. Supports weight capacity of 375 lbs. (excluding work surface weight). Can be used with 48” 120 degree and work surface models.**

⚠ When using two work surfaces, a flat bracket is required. Bracket purchased separately — HHN831124, HHN831130 — see page 589.

⚠ Telescoping horizontal frame will extend just over 2” from underside of the work surface.

NOTES:



- Height Adjustable Bases ship complete with a pre-assembled motor.
- Base telescopes to accommodate any work surface between 48”W and 72”W.

⚠ Coordinate™ Height Adjustable Bases not compatible with 36”D rectangular work surfaces.

HOW TO SPECIFY

<p>Select Model Number</p> <p>HHAB2S2L .</p>	<p>Select Finish</p> <p>P71 Black P8L Nickel PD8 White</p> <p>P8L</p>
--	---

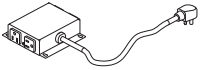
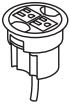

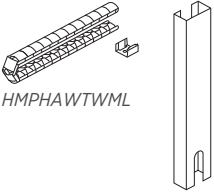
	DESCRIPTION	MODEL	SHIP WEIGHT	CUBE	LIST PRICE
 SIN 33721	<p>Under Worksurface Power Module – 4 Outlets, 10' Cord</p> <ul style="list-style-type: none"> Includes 10' cord with three-prong plug. Fits in cable management troughs. See page 852. 4 outlets on side create easy access. <p>NOTES: Power Modules will also work with standing-height applications for 10500 Series™ and Voi® desks. For additional information see page 849.</p> <p>ⓘ Available in black finish only, no specification needed.</p>	HPWRMOD2	1.5	0.2	\$401
 SIN 33721T	<p>3' Round Power Grommet – 2 Outlets, 10' Cord</p> <ul style="list-style-type: none"> Includes 10' cord with three-prong plug. Fits in 3" round grommet holes. Two grounded AC power outlets. Field installed with Plug-and-play ease. <p>ⓘ Available in black finish only, no specification needed.</p>	HGRMTAC2	1.5	0.2	\$148
 SIN 33721	<p>Flat Bracket</p> <p>24"D 30"D</p> <ul style="list-style-type: none"> Charcoal only. Must be used if specifying 2 worksurfaces for HHAB3S3L base. 	<p>HHN831124 HHN831130</p>	<p>3.0 ⓘ 3.0 ⓘ</p>	<p>0.3 0.4</p>	<p>\$64 \$64</p>
 HMPHAWTWML HMPHATFWML	<p>Wire Managers for Height Adjustable</p> <p>Workstation to Trough Trough to Floor</p> <p>ⓘ Wire Manager Workstation to Trough only available in black.</p>	<p>HMPHAWTWML HMPHATFWML</p>	<p>3.0 2.0</p>	<p>0.1 0.3</p>	<p>\$264 \$249</p>
OPEN MARKET					

HOW TO SPECIFY

Select Model Number

H P W R M O D 2

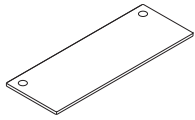

DESCRIPTION	MODEL	SHIP WEIGHT	CUBE	L1 LIST PRICE	L2 LIST PRICE
Systems Rectangle Worksurfaces for Height Adjustable Bases					
46"W x 23¼"D	HHAW2448P	58	3.3	\$429	\$444
52"W x 23¼"D	HHAW2454P	64	4.0	\$451	\$471
58"W x 23¼"D	HHAW2460P	70	4.0	\$499	\$519
64"W x 23¼"D	HHAW2466P	86	4.8	\$535	\$555
70"W x 23¼"D	HHAW2472P	89	4.8	\$552	\$572

❗ Must be used as worksurfaces on Coordinate™ Height Adjustable Bases within Panel Systems, as these are 1" shorter in width on each side to provide clearance between panels and other worksurfaces.

❗ Available in all standard systems' laminate and edgebanding options. Only offered with grommets.

Specify Model.LaminateColor.EdgeColor.GrommetColor SPECIFYING EXAMPLE: HHAW2448P.A5.K.T1

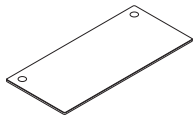

Systems Rectangle Worksurfaces for Height Adjustable Bases					
46"W x 29¼"D	HHAW3048P	68	4.0	\$458	\$473
52"W x 29¼"D	HHAW3054P	80	5.0	\$491	\$511
58"W x 29¼"D	HHAW3060P	101	5.0	\$544	\$564
64"W x 29¼"D	HHAW3066P	105	6.0	\$578	\$598
70"W x 29¼"D	HHAW3072P	105	6.0	\$616	\$636

❗ Must be used as worksurfaces on Coordinate™ Height Adjustable Bases within Panel Systems, as these are 1" shorter in width on each side to provide clearance between panels and other worksurfaces.

❗ Available in all standard systems' laminate and edgebanding options. Only offered with grommets.

Specify Model.LaminateColor.EdgeColor.GrommetColor SPECIFYING EXAMPLE: HHAW3048P.A5.K.T1

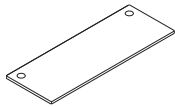

Voi® Rectangle Worksurfaces for Height Adjustable Bases					
48"W x 24"D	HLSLR2448	61	3.4	\$300	\$315
54"W x 24"D	HLSLR2454	68	4.2	\$323	\$343
60"W x 24"D	HLSLR2460	75	4.2	\$351	\$371
66"W x 24"D	HLSLR2466	82	5.0	\$380	\$400
72"W x 24"D	HLSLR2472	89	5.0	\$394	\$414
48"W x 30"D	HLSLR3048	75	4.2	\$323	\$338
54"W x 30"D	HLSLR3054	84	5.1	\$360	\$380
60"W x 30"D	HLSLR3060	92	5.1	\$402	\$422
66"W x 30"D	HLSLR3066	101	6.1	\$432	\$452
72"W x 30"D	HLSLR3072	110	6.1	\$469	\$489

❗ For use with Coordinate™ Height Adjustable Bases only in Freestanding Applications, which are applications where the tables/desks are not attached or adjacent to another unit, table/desk or systems panel. The widths are true to stated dimensions. If used with Panel Systems or other than in Freestanding Applications, worksurfaces will not provide proper clearance between panels or other worksurfaces, and may cause injury or worksurface damage (not covered by warranty).

❗ Coordinate™ Height Adjustable Bases not compatible with 36"D rectangular worksurfaces.

❗ See page 188 for specifying information.

NOTES:

• Systems Rectangle Worksurfaces for Height Adjustable Bases designed for use in panel systems. Worksurface is 2" shorter in width and ¾" shorter in depth than standard worksurfaces to provide clearance between panels and other worksurfaces.

HOW TO SPECIFY

<p>Select Model Number</p> <p>HHAW2448P HLSLR2448</p>	<p>Select Laminate</p> <p>See page 441 *For Voi® Worksurfaces only, see page 171</p> <p>A5 NN</p>	<p>Select Edge Color</p> <p>See page 441 Specify for Systems Worksurfaces only</p> <p>K</p>	<p>Select Grommet Color</p> <p>See page 441 Specify for Systems Worksurfaces only</p> <p>T1</p>	<p>Select Grommet Option and Color</p> <p>Specify for Voi® Worksurfaces only</p> <p>X No Grommet G Grommet</p> <p>If choosing the grommet option Select Grommet Color</p> <p>P Black Grommet DW Designer White Grommet T5 Greige Grommet T1 Platinum Grommet</p> <p>GT5</p>
--	--	--	--	--

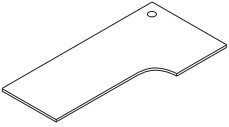
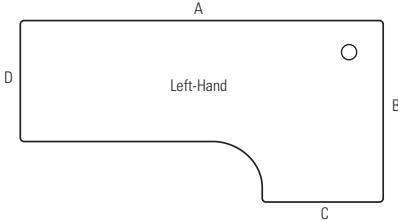
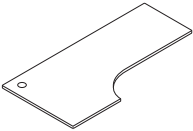
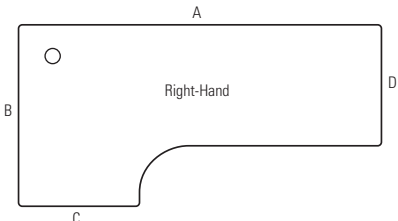

DESCRIPTION	MODEL	SHIP WEIGHT	CUBE	L1	L2	
				LIST PRICE	LIST PRICE	
 <p>Corner Cove Worksurfaces for Height Adjustable Bases, Left Hand 58" A x 34" B x 23" C x 23" D 70" A x 34" B x 23" C x 23" D</p> <p>58" A x 46" B x 23" C x 23" D 58" A x 46" B x 29" C x 29" D 70" A x 46" B x 23" C x 23" D 70" A x 46" B x 29" C x 29" D</p> 	HHAWV603624LP	67	6.1	\$606	\$631	
	HHAWV723624LP	75	6.8	\$665	\$695	
	HHAWV604824LP	85	7.4	\$665	\$695	
	HHAWV604830LP	99	7.4	\$712	\$742	
	HHAWV724824LP	105	8.8	\$830	\$865	
	HHAWV724830LP	112	8.8	\$880	\$915	
	 <p>Corner Cove Worksurfaces for Height Adjustable Bases, Right Hand 58" A x 34" B x 23" C x 23" D 70" A x 34" B x 23" C x 23" D</p> <p>58" A x 46" B x 23" C x 23" D 58" A x 46" B x 29" C x 29" D 70" A x 46" B x 23" C x 23" D 70" A x 46" B x 29" C x 29" D</p> 	HHAWV603624RP	67	6.1	\$606	\$631
		HHAWV723624RP	75	6.8	\$665	\$695
		HHAWV604824RP	85	7.4	\$665	\$695
		HHAWV604830RP	99	7.4	\$712	\$742
HHAWV724824RP		105	8.8	\$830	\$865	
HHAWV724830RP		112	8.8	\$880	\$915	

NOTES:

- Corner Cove Worksurfaces for Height Adjustable Bases designed for use in panel systems. Worksurface is 1" shorter in width and 1" shorter in depth on side of corner to provide clearance between panels and other worksurfaces.
- Use the 3-Leg Coordinate™ Base when specifying Coordinate™ Corner Cove Surfaces.

HOW TO SPECIFY

<p>Select Model Number</p> <p>HHAWV603624LP.</p>	<p>Select Laminate</p> <p>See page 441</p> <p>A5.</p>	<p>Select Edge Color</p> <p>See page 441</p> <p>K.</p>	<p>Select Grommet Color</p> <p>See page 441</p> <p>T1</p>
--	---	--	---

COORDINATE™ Desktop Riser & Sit-to-Stand Devices

OPEN MARKET

Icon Legend on page 19

DESCRIPTION

MODEL

SHIP WEIGHT

CUBE

LIST PRICE



Portable Desktop Riser

31"D x 5'-16½"H x 35"W

HBXRISER

54.0

4.1

\$619

NOTES: Available in Black (BLK) or White (WHT) finish. Desktop riser dimensions (without keyboard tray): 22"D x 5'-16½"H x 35"W. Keyboard tray dimensions: 9"D x 30"W. Max loading capacity is 33 lbs for the desktop riser surface and 4 lbs for the keyboard tray. Easily transition from seated to standing positions throughout the workday. Sits atop an existing desk to create sit-to-stand functionality by raising the computer. Includes keyboard tray and surface for computer monitors. **HON 5-Year Limited Warranty.**

⚠ Not intended for use on mobile workstations.

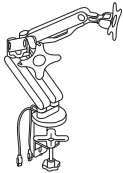

Dual Monitor Arm with 2 USB Ports

HBDMAUSB

41.9

2.6

\$441

NOTES: Easy adjustment. Height adjusts to 17" tall. Monitor tilt and swivel capability. Enclosed cable management. Grommet or desktop mounting. Clean appearance. In some applications the Monitor Arms may extend 12 or more inches into the worksurface. **HON 5-Year Limited Warranty.**

⚠ No specification needed.

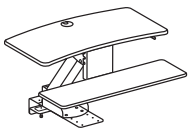

Mounted Desktop Riser

HS1100

60.0 Ⓢ

3.2

\$664

NOTES: Does not include a monitor arm and is suitable for laptops and/or monitors on their original stands.

⚠ No specification needed.

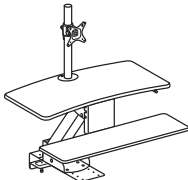

Mounted Desktop Riser with Single Monitor Arm

HS1101

62.0 Ⓢ

3.2

\$777

NOTES: Includes a monitor arm for a single monitor.

⚠ No specification needed.

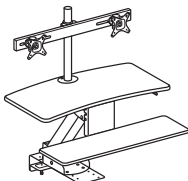

Mounted Desktop Riser with Dual Monitor Arm

HS1102

63.0 Ⓢ

3.2

\$883

NOTES: Includes a monitor arm for dual monitors.

⚠ No specification needed.

WORKPLACE TOOLS

NOTES FOR HS1100, HS1101, HS1102:

- These products are designed to allow the user to transition from seating position to standing position throughout the workday.
- Gas-assist lever-operated mechanism with positive stop.
- Clamp mount compatible with worksurfaces depths of 20"-30". 20" is for systems only.
- Clamp requires 3.5" of clearance along back edge of worksurface.
- Black seamless worksurfaces.
- Silver powder coated metal components.
- Lowers below worksurface level on 24" and 30"D worksurfaces.
- All models contain a large primary worksurface and a smaller keyboard / mouse surface.
- Beveled edges for sleek appearance and comfort while typing.
- Monitor arms include height, width, and swivel adjustment.

- Not for use under overhead storage, with flush mounted modesty panels, or worksurfaces thinner than 1".

⚠ Not recommended for use on mobile (castered) worksurfaces.

MOUNTING AND COMPATIBILITY FOR HS1100, HS1101, HS1102:

- This product is intended to be installed on commercial-grade worksurfaces in good condition.
- Compatible with freestanding worksurfaces 24"-30"D or panel-supported worksurfaces 24"-30"D.
- Not for use on mobile worksurfaces.

Clamp Mount

Use when 3.5" minimum overhang is available

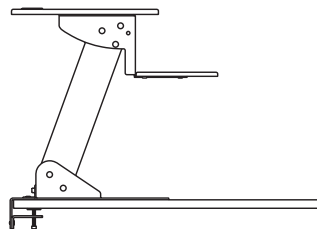

Screw Mount

Use when no overhang is available. Worksurface must be minimum 1" thick.

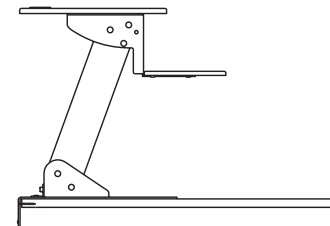

HOW TO SPECIFY

Select Model Number

HBXRISER.

Select Finish



BLK Black
WHT White

BLK



WORKPLACE TOOLS

Ergonomic Solutions

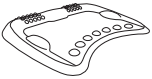
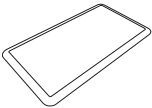
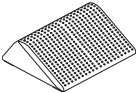
	DESCRIPTION	MODEL	SHIP WEIGHT	CUBE	LIST PRICE
	Rectangle Wobble Board — Anti-Fatigue Mat 18"D x 3"H x 22¼"W ⓘ Available in Black (T) finish ONLY. Recommended weight capacity not to exceed 250 pounds. HON 5-Year Limited Warranty. SPECIFYING EXAMPLE: HVL981.T	HVL981	10.0 ⓘ	0.9	\$120
	Round Wobble Board — Anti-Fatigue Mat 18½"D x 2⅝"H x 18½"W ⓘ Available in Black (T) finish ONLY. Recommended weight capacity not to exceed 250 pounds. HON 5-Year Limited Warranty. SPECIFYING EXAMPLE: HVL982.T	HVL982	5.8 ⓘ	0.6	\$102
	Ergonomic Anti-Fatigue Mat 25"D x 2¾"H x 29⅞"W ⓘ Available in Black ONLY. No specification needed. HON 5-Year Limited Warranty. SPECIFYING EXAMPLE: HBEAFM1	HBEAFM1	7.0	1.4	\$219
	Rectangle Anti-Fatigue Mat 20"D x ¾"H x 36"W ⓘ Available in Black ONLY. No specification needed. HON 5-Year Limited Warranty. SPECIFYING EXAMPLE: HBAFM2036	HBAFM2036	5.4	0.4	\$100
	Footrest — Anti-Slip Cover 13¾"D x 5½"H x 16"W ⓘ Available in Black (T) finish ONLY. Recommended weight capacity not to exceed 250 pounds. HON 5-Year Limited Warranty. SPECIFYING EXAMPLE: HVL991.T	HVL991	7.0 ⓘ	0.9	\$82

HOW TO SPECIFY

Select Model Number H V L 9 8 1 .	Select Finish T Black
---	---------------------------------

WORKPLACE TOOLS

Chair Mats

OPEN MARKET

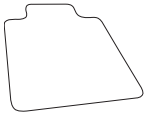
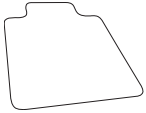
	DESCRIPTION	MODEL	SHIP WEIGHT	CUBE	LIST PRICE
	Lipped Chair Mat with Studs				
	60"W x 46"D 48"W x 36"D	HCM4660LS	13.9	1.0	\$146
		HCM3648LS	8.8	0.6	\$88
	Lipped Chair Mat without Studs				
	60"W x 46"D 48"W x 36"D	HCM4660LN	13.2	0.5	\$146
		HCM3648LN	8.3	0.3	\$88

NOTES:

- Available with studs for carpet and without studs for hard-surface floors.
- Ships rolled.
- **HON 5-Year Limited Warranty.**

❗ Clear finish only. No specification needed.

HOW TO SPECIFY

Select
Model Number

H C M 4 6 6 0 L S



TASK LIGHTS

	DESCRIPTION	MODEL	SHIP WEIGHT	CUBE	LIST PRICE
	Articulating Desk Lamp Articulating Desk Lamp w/ Occupancy Sensor <ul style="list-style-type: none"> • Color: Matte Silver. • Full-range dimming from 10% to 100%. • Designed for 50,000 hours of life. • Occupancy sensor is built into the head of the lamp and will automatically shut the lamp off after 6 minutes of undetected movement. • Base swivel is 180 degrees. • Uses only 5 watts of energy. • Light comes with a silver 9' 4" power cord. • Base diameter is 7.5". • 3500K Color Temperature. • 80 Color Rendering Index. • TAA Compliant. 	HLED1 HLED10C	1.2 Ⓞ 1.2 Ⓞ	6.5 6.5	\$402 \$490
	Task Desk Lamp <ul style="list-style-type: none"> • Color: Brushed Nickel. • Full-range dimming from 10% to 100%. • Designed for 50,000 hours of life. • Lamp is 15.83" tall. • Desk lamp does not articulate at base. The pivoting head provides custom positioning, as it can be twisted 360 degrees. • Uses only 5 watts of energy. • Light comes with a silver 9' 4" power cord. • Base diameter is 6.7". • 3500K Color Temperature. • 80 Color Rendering Index. • TAA Compliant. 	HLED2	0.7 Ⓞ	3.0	\$348

HOW TO SPECIFY

Select Model Number

H L E D 1

TASK LIGHTS

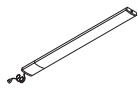

DESCRIPTION

LED Task Lights

17" LED Light with Power Supply (Single)

31" LED Light with Power Supply (Single)

17" LED Light with Power Supply for Daisy-chain (Starter)

31" LED Light with Power Supply for Daisy-chain (Starter)

17" LED Light with 8" Jumper Cord for Daisy-chain (Follower)

31" LED Light with 8" Jumper Cord for Daisy-chain (Follower)

Undercabinet Occupancy Sensor with 1" End to End Connector

MODEL

SHIP WEIGHT

CUBE

LIST PRICE

HLED17AS

1.2

0.05

\$420

HLED31AS

1.5

0.09

\$565

HLED17A

1.0

0.05

\$462

HLED31A

1.4

0.09

\$620

HLED17AUO

1.0

0.03

\$377

HLED31AUO

1.0

0.05

\$502

HLEDOSA

0.2

0.01

\$89

NOTES: To use the daisy chain application, must start with model HLED17A or HLED31A. No finish specification required. Attaches magnetically to underside of overhead storage or attaches with provided screws. Occupancy sensor attaches to a single or starter LED light and will automatically turn the light off after no motion is detected for 30 minutes. Just like all the LED light models, the occupancy sensor features a soft-touch on/off switch. LED task lights have a lifetime of 50,000 hours and have a dimmer feature that allows the user to adjust the amount of light output.



Recessed Task Lights

- Color: Black.
- Slim profile design.
- Mount to stack-on storage and wall mounted storage cabinets.
- Electronic ballast for increased energy efficiency.
- T5 bulb, included, which contains less mercury.
- 9-foot black cord and switch off right rear corner.

18⁵/₈"W x 3¹/₁₆"D x 1¹/₈"H

Chicago code version (with fused plug)

HH870924

5.0

0.40

\$227

22¹/₈"W x 3¹/₁₆"D x 1¹/₈"H

Chicago code version (with fused plug)

HH870924CH

5.0

0.40

\$287

22¹/₈"W x 3¹/₁₆"D x 1¹/₈"H

Chicago code version (with fused plug)

HH870930

7.0

0.60

\$231

34⁵/₈"W x 3¹/₁₆"D x 1¹/₈"H

Chicago code version (with fused plug)

HH870930CH

7.0

0.60

\$301

34⁵/₈"W x 3¹/₁₆"D x 1¹/₈"H

Chicago code version (with fused plug)

HH870942

10.0

0.90

\$250

46¹/₂"W x 3¹/₁₆"D x 1¹/₈"H

Chicago code version (with fused plug)

HH870942CH

10.0

0.90

\$317

46¹/₂"W x 3¹/₁₆"D x 1¹/₈"H

Chicago code version (with fused plug)

HH870960

12.0

1.10

\$270

HH870960CH

12.0

1.10

\$337

HOW TO SPECIFY

Select
Model Number

H H 8 7 0 9 2 4

PAPER MANAGEMENT & ORGANIZATIONAL TOOLS

GSA SIN 33721



Icon Legend on page 19

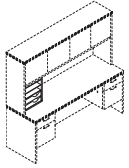

Not available in two-tone laminate

DESCRIPTION

Vertical Paper Manager
14⁷/₈"W x 10⁷/₈"D x 19³/₈"H

MODEL

HLVPM1

SHIP WEIGHT

27

CUBE

2.8

L1 LIST PRICE

\$327

L2 LIST PRICE

\$337

NOTES: Keeps papers, files, and books neatly organized and within easy reach from a seated position. Designed for desk, credenza, and return tops. Fits under stack-on storage models. Two pullout drawers and three fixed shelves. Not available in pattern laminate colors. Ships fully assembled.

⚠ Requires 19³/₄"H minimum of clear space between underside of overhead storage unit and worksurface.

SPECIFYING EXAMPLE: HLVP1.N

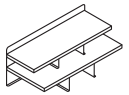

Not available in two-tone laminate



Desktop Storage Terrace

26¹/₂"W x 12¹/₂"D x 10¹/₂"H

HLDST1

24

1.1

\$306

\$316

NOTES: For use on the tops of 29¹/₂"H desks, credenzas, and returns. Features six storage sections plus top display shelf. Keeps work-in-process, priority files, loose pages, and mail neatly organized and in view. Mixed material design comprised of sturdy laminate shelves with metal back and support panels. Not available in two-tone laminate combination or pattern laminate colors. Choose from Platinum Metallic (T1), Black (P), and Charcoal (S) for the metal components. Sized to fit in stack-on and wall mount storage cabinets in 10500, 10700, Valido, Concinnity, 94000, and 38000 Series. Fits in Concinnity and Voi sliding door models, except for 48"W or smaller models. Specify: Model.Laminate.Paint

SPECIFYING EXAMPLE: HLDST1.N.T1

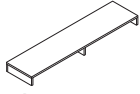

Layering Shelf

72"W x 14¹/₂"D x 5¹/₂"H

HLSL1472LS

50

4.6

\$435

\$445

60"W x 14¹/₂"D x 5¹/₂"H

HLSL1460LS

39

1.3

\$364

\$374

NOTES: Layering shelf works with lower credenzas to provide additional storage areas.

⚠ Layering Shelves cannot be stacked.

⚠ Cannot add a hutch on top of a layering shelf.

HOW TO SPECIFY

<p>Select Model Number</p> <p>HLVPM1 . N</p>	<p>Select Laminate</p> <p>See page 824</p>
---	---



PAPER MANAGEMENT & ORGANIZATIONAL TOOLS

DESCRIPTION

MODEL SHIP WEIGHT CUBE LIST PRICE

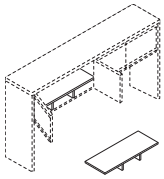

Stacked Paper Management
32½"W x 12⅝"D x 4¼"H

HLVPM2 22 1.25 \$163

NOTES: Segments and organizes stack-on and wall mount storage compartments, as well as bookcase shelves. Unit can be used in Models H105327, H10534, H105322, H105321, H105382 and H105381.

- ! Available in Black finish only, no specification needed.
- ! In some cases, installation of Stacked Paper Management may require removing the stack-on or wall mount storage doors.

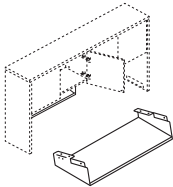

Hanging Paper Shelf
28⅞"W x 11⅞"D x 4⅝"H

HHPS1 7 2.9 \$198

NOTES: Attaches quickly and easily (screws included). Maximizes worksurface space; de-clutters desktop while placing priority communications and active project folders within easy reach. Angled design allows contents to be distinguished at a glance. Mixed material styling features strong painted metal frame with a frosted shelf.

Attaches quickly and easily to laminate stack-on and wall mount storage models (except the 36"W Voi® overhead hutch with O-legs or panel mount brackets). Not for use with 38000 Series™ and Systems.

Specify: Model.Paint
SPECIFYING EXAMPLE: HHPS1.T1

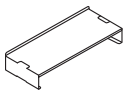

Desktop Paper Shelf
28⅞"W x 11⅝"D x 5"H

HDPS1 7 2.9 \$198

NOTES: Desktop Paper Shelf and Storage Terrace include protective, non-slip pads on the base. Paper Shelf can stack two-high. Organizer shelf provides a place and space for work-in-process and piling to keep worksurfaces neat and tidy. Convenient, scalable design with interlocking side supports allow two units to be stacked and integrated. Durable painted metal frame with a frosted shelf; mixed material styling matches hanging paper shelf.

Can also be used inside select overhead storage, including the following stack-on with clearance and hinged door models: 10500 and Valido 36", 42", 66", 72", 78"W and 10700 68⅝"W.

Specify: Model.Paint
SPECIFYING EXAMPLE: HDPS1.T1

HOW TO SPECIFY





<p>Select Model Number</p> <p>HLVPM2 . N</p>	<p>Select Paint Color</p> <p>See page 824</p>
---	--

PAPER MANAGEMENT & ORGANIZATIONAL TOOLS

GSA SIN 33721 EXCEPT AS NOTED

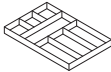
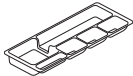
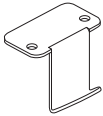

Icon Legend on page 19

	DESCRIPTION	MODEL	SHIP WEIGHT	CUBE	LIST PRICE
 	Storage Cube 12"W x 12"D SPECIFYING EXAMPLE: HLSL1212.P8S	HLSL1212	1.0	0.3	\$294
	Drawer Organizer 12"W x 14½"D x 1½"H SPECIFYING EXAMPLE: HSLDRWORG.P8F	HSLDRWORG	1.0	0.5	\$156
	Optional Pencil Tray ⓘ For use with mobile and freestanding pedestal models. ⓘ No specification required.	HV-UT1	0.5	0.1	\$66
 OPEN MARKET 	Back Pack Hook (10 per carton) 12"W x 14½"D x 1½"H NOTES: Assembly: attaches to bottom of desk with (2) screws, included. ⓘ Available in Platinum Metallic finish only, no specification needed.	HCLA65	10.0 ⓘ	0.1	\$94

WORKPLACE TOOLS

HOW TO SPECIFY

Select Model Number	Select Paint Color See page 824 Only specify for models HLSL1212 and HSLDRWORG
H L S L 1 2 1 2 .	P 8 S



Icon Legend on page 19

PAPER MANAGEMENT & ORGANIZATIONAL TOOLS





	DESCRIPTION	MODEL	SHIP WEIGHT	CUBE	LIST PRICE
	Wall Mount 36" W x 35¼"H	HNL3636TB	20	2.9	\$300
	30"W x 35¼"H	HNL3630TB	16	2.9	\$256
	36"W x 48⅝"H	HNL4936TB	27	5.5	\$334
	30"W x 48⅝"H	HNL4930TB	22	3.7	\$290
	NOTES: When positioned above 29½"H floor-standing storage, the sizes align with overhead storage height options. Can be positioned side-by-side with corresponding wall mount sizes. Easy to install; includes mounting hardware. Attaches to wall with horizontally mounted, interlocking Z-clip brackets. For the space directly below stack-on and wall mount storage cabinets, use the 18" H models listed in the Desks section.				
	SPECIFYING EXAMPLE: HNL3636TB.APN15				
	Wall Mount 36"W x 35¼" H	HNL3636WB	16	2.9	\$204
	30"W x 35¼"H	HNL3630WB	14	2.9	\$191
	36"W x 48⅝"H	HNL4936WB	22	5.5	\$251
	30"W x 48⅝"H	HNL4930WB	20	3.7	\$231
	NOTES: Smooth, white, magnetic surface. Metal material produces clear graphics and cleans easily. Compatible for use with dry- or wet-erase markers. When positioned above 29½"H floor-standing storage, the sizes align with overhead storage height options. Can be positioned side-by-side with corresponding wall mount sizes. Easy to install; includes mounting hardware. Attaches to wall with horizontally mounted, interlocking Z-clip brackets.				
	SPECIFYING EXAMPLE: HNL3636WB				
	48"W x 31"H	HLSL4831MB	44	3.4	\$664
	NOTES: Wall mounted. ! No specification required.				
OPEN MARKET 					

WORKPLACE TOOLS

HOW TO SPECIFY

<p>Select Model Number</p> <p>H N L 3 6 3 6 T B</p>	<p>Select Fabric Color</p> <p>See pages 25-26</p> <p>A P N 1 1</p>
---	--

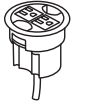
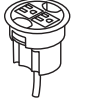
POWER & CABLE MANAGEMENT

	DESCRIPTION	MODEL	SHIP WEIGHT	CUBE	LIST PRICE
 <p>Black only SIN 33721</p>	<p>Black Field Installable Grommet with One Access Hole</p> <ul style="list-style-type: none"> Intended for use in tops and end panels to route/hide cords and facilitate reaching wall electrical outlets. Requires a 2½" diameter hole saw and drill for installation (not included). Grommet cap measures 3" diameter and includes a ¾" diameter cord access hole. Grommet sleeve measures 2½" O.D. x ¾" thick. Includes instructions to locate grommet position for desks, credenzas, returns and bridges. <p>⚠ The grommet is not designed to be used with the following HON Series: 94000, 38000, Mentor®, Metro Classic or 34000.</p>	HFLDGRMT	0.1 Ⓢ	0.01	\$32
 <p>SIN 33721</p>	<p>Black Field Installable Grommet with Two Access Holes</p> <ul style="list-style-type: none"> Requires a 3" diameter hole saw and drill for installation (not included). Grommet outside dimensions measures 3½" diameter. Grommet sleeve measures 3" O.D. x 1" thick. Includes instructions to locate grommet position for desks, credenzas, returns and bridges. 	HFLDGRMT3	0.1 Ⓢ	0.3	\$32
 <p>OPEN MARKET</p>	<p>Platinum Field Installable Grommet with Two Access Holes</p> <ul style="list-style-type: none"> Requires a 3" diameter hole saw and drill for installation (not included). Outside dimension measures 3½" diameter. Sleeve hole in worksurface measures 3" O.D. x 1" thick. Includes instructions to locate grommet position for desks, credenzas, returns, and bridges. 	HFLDGRMT4	0.1	0.01	\$32
 <p>SIN 33721T</p>	<p>Power Hub, 3" Grommet Mount, 6' Cord</p> <ul style="list-style-type: none"> Fits in 3" round grommet holes. Two grounded AC power outlets. Includes 6' cord with three-prong plug. Field installed with Plug-and-play ease. <p>⚠ Available in black only (no color designation so use .X - Specify: HGRMTAC.X).</p>	HGRMTAC	1.3	0.2	\$111
 <p>SIN 33721T</p>	<p>3" Round Power Grommet - 2 Outlets, 10' Cord</p> <ul style="list-style-type: none"> Includes 10' cord with three-prong plug. Fits in 3" round grommet holes. Two grounded AC power outlets. Field installed with Plug-and-play ease. <p>NOTES: Power Modules will also work with standing-height applications for 10500 Series™ and Voi® desks. Optional Memory Control allows preset worksurface heights for consistency. Ships separately. Dynamic load capacity when worksurface is moving is 300 lbs.</p> <p>⚠ Available in black finish only, no specification needed.</p>	HGRMTAC2	1.5	0.2	\$148
 <p>SIN 33721T</p>	<p>Power/USB Hub, 3" Grommet Mount</p> <ul style="list-style-type: none"> One grounded AC power outlet with 2 USB ports. UL Listed. <p>⚠ Available in black only (no color designation so use .X - Specify: HGRMTUSB2.X).</p> <p>⚠ Not compatible with Arrange® tables.</p>	HGRMTUSB2	1.3 Ⓢ	0.2	\$224
 <p>SIN 33721</p>	<p>Data Grommet</p> <p>Blank grommet kit that includes adapters for a variety of manufacturers jacks and couplers.</p> <ul style="list-style-type: none"> Fits in existing 3" round grommet housing. <p>⚠ Available in black only. Specify P when ordering. Example: HGRMTDATA.P.</p>	HGRMTDATA	0.2	0.2	\$19

HOW TO SPECIFY

Select
Model Number

H F L D G R M T



Icon Legend on page 19

POWER & CABLE MANAGEMENT

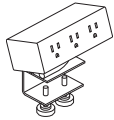

Model HPWRMOD3WC shown

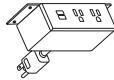

Model HPWRMOD2UWM shown

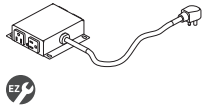
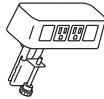

DESCRIPTION

Power Modules

- 3 Receptacles with Worksurface Clamp
- 3 Receptacles with Under-Worksurface Mounting Bracket
- 2 Receptacles 2 USB with Worksurface Clamp
- 2 Receptacles 2 USB with Under-Worksurface Mounting Bracket
- 6' power cord with standard three-prong plug.
- Under-worksurface mounting bracket models work with any top that has a 5" x 5" square clearance.
- Worksurface clamp models work on any top with a 4" overhang.
- UL Listed.

! Finish choices coordinate with HON's Charcoal or Designer White. Specify *STRM* for Storm or *SNW* for Snow.
Example: *HPWRMOD3WC.STRM*.

MODEL

SHIP WEIGHT

CUBE

LIST PRICE

HPWRMOD3WC	2.3 Ⓢ	0.2	\$307
HPWRMOD3UWM	2.3 Ⓢ	0.2	\$307
HPWRMOD2WC	2.3 Ⓢ	0.2	\$491
HPWRMOD2UWM	2.3 Ⓢ	0.2	\$491

Power & Data Center

- 2 Receptacles 2 Data Accessory
- Standard with two receptacles and openings for two data ports.
- 6' power cord with standard three-prong plug.
- Fits on any worksurface with a 4" overhang.
- UL Listed.

! Color finish coordinates with HON's Loft. Specify *LOFT* when ordering. Example: *HCOMDOME2.LOFT*.

HCOMDOME2

2.5 **Ⓢ**

0.2

\$293

Under Worksurface Power Module — 4 Outlets, 10' Cord

- Includes 10' cord with three-prong plug.
- Fits in cable management troughs. See page 851.
- 4 outlets on side create easy access.

NOTES: Power Modules will also work with standing-height applications for 10500 Series™ and Voi® desks.

! Available in black finish only, no specification needed.

HPWRMOD2

1.5

0.2

\$401

HOW TO SPECIFY

Select Model Number

H P W R M O D 3 W C

POWER & CABLE MANAGEMENT

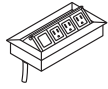

DESCRIPTION

Pop-up Port

- Fits into 4" x 8" cutout.
- Specify G1 cutout in table top.
- Pop-up Port provides three power ports and one blank data receptacle.
- Sits flush with worksurface when closed.
- Finish is anodized aluminum.
- Includes 6' cord with three-prong plug.

MODEL

HTPWRGROM1

SHIP WEIGHT

5

CUBE

0.3

LIST PRICE

\$392

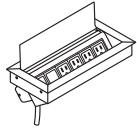

Flip-top Port

- Fits into 5" x 11" cutout.
- Specify G2 cutout in table top.
- Flip-top Port provides four power ports and two blank data receptacles.
- Conceals wires and allows power cords to be plugged in while in use.
- Includes 10' cord with three-prong circuit breaker plug.

HTPWRGROM2

5

0.3

\$579

NOTES: Two circuit breaker plugs do not fit into one duplex.

Flip-top Port

- Fits into 5" x 11" cutout.
- Specify G2 cutout in table top.
- Flip-top Port provides one blank Extron plate and three power ports.
- Extron AAP plates can be integrated into grommet to support changing technology.
- Conceals wires and allows power cords to be plugged in while in use.
- Includes 10' cord with three-prong circuit breaker plug.

HTPWRGROM4

5

0.3

\$710

Flip-top Port

- Fits into 5" x 11" cutout.
- Specify G2 cutout in table top.
- Flip-top Port provides 3 Power, 1 USB and 2 Blank Data Ports.
- Conceals wires and allows power cords to be plugged in while in use.
- Includes 10' cord with three-prong circuit breaker plug.

HTPWRGROM5

5

0.3

\$841

HOW TO SPECIFY

Select
Model Number

H T P W R G R O M 1



POWER & CABLE MANAGEMENT

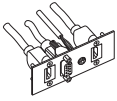

DESCRIPTION	MODEL	SHIP WEIGHT	CUBE	LIST PRICE
Extron Plate (Double Space) — VGA, HDMI, HDMI, Audio	HTPLATEVHAU	1	0.1	\$399

NOTES:

- 1 Double Space plate can be used in a single HTPWRGROM4 flip-top port.
- ! Extron plates can be retrofitted to be used on HTPWRGROM4.

HOW TO SPECIFY

Select Model Number

H T P L A T E V H A U

POWER & CABLE MANAGEMENT

Icon Legend on page 19

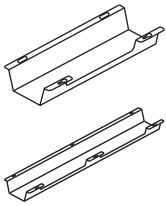

DESCRIPTION

Cable Management Troughs

- 17"W — Single
- 17"W — 10-Pack
- 36"W — Single
- 36"W — 10-Pack

- Cable management troughs ship flat packed.
- The troughs attach to underneath the worksurface with screws.
- Cutouts in trough allow access to power without the need to detach from surface. 17"W = 1 cutout; 36"W = 2 cutouts.
- Color: Graphite.
- Material: Metal.
- TAA Compliant.

MODEL

SHIP WEIGHT

CUBE

LIST PRICE

HCTROUGH17	2.7	0.5	\$67
HCTROUGH1710	14.0	0.5	\$620
HCTROUGH36	4.9	0.9	\$113
HCTROUGH3610	30.0	0.9	\$1045



OPEN MARKET

O-Leg Cord Clips

- Clips for 28½" Worksurface O-Legs — 8-Pack
- Clips for Stack-on Storage, Hutch and Layering O-Legs — 4-Pack

HWMCLIPLG

0.8

0.1

\$99

HWMCLIPSM

0.5

0.1

\$65

NOTES: Wire clips work with 7" Low Credenza O-leg and 29"H Support O-leg. Wire clips also work with the 50" and 65" Overhead O-leg supports.

Available in frosted plastic material only.

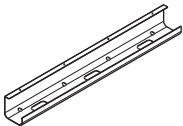

Black only

Cable Management Tray

- 24"
- 36"

Available in Black only.

HHCMT24

2.0

0.3

\$73

HHCMT36

3.0

0.4

\$90



Vertical Wire Management Vertebrae

HMPVWM28

3.0

0.3

\$221

NOTES: 30"H x 3⅞"W x 1½"D. Ships unassembled.

Clear finish. Specify "X" for finish option.

SPECIFYING EXAMPLE: HMPVWM28.X

WORKPLACE TOOLS

HOW TO SPECIFY

Select Model Number

Select Paint Color

P Black









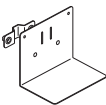

H H C M T 2 4 .

P

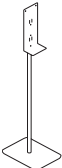
HEALTHY WORKPLACE TOOLS

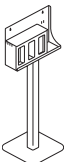

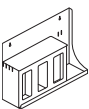
Icon Legend on page 19

	DESCRIPTION	MODEL	SHIP WEIGHT	CUBE	LIST PRICE BY PAINT GRADE		
					P1	P2	P3
	Hand Sanitizer Station Mounting Area: 6"W x 12"H Base: 12"W x 16"H NOTES: Freestanding. Stand is compatible with most manufacturers' automatic hand sanitizer dispensers, sold separately. No assembly required. Metal base for added stability.	HHC-SANSTND	15.0 	6.1	\$256	\$282	\$294
	Retrofit Tray Kit for Sanitizer Station NOTES: Allows for easy conversion of HHC-SANSTND to HHC-SANSTND2. Adjustable strap allows for usage with most hand sanitizer bottles with pump or wipe containers.	HHC-SANSTND-TRAY	8.0 	0.2	\$75	\$88	\$94
	Hand Sanitizer Station with Tray NOTES: Freestanding. Stand is compatible with most manufacturers' automatic hand sanitizer dispensers, sold separately. Adjustable strap allows for usage with most hand sanitizer bottles with pump or wipe containers. No assembly required. Metal base for added stability.	HHC-SANSTND2	15.0 	6.1	\$295	\$321	\$333
	Freestanding PPE Stand NOTES: Freestanding. 3 closed compartments fit most manufacturers' boxed PPE, including gloves, masks, wipes, and tissues. Closed compartments have adjustable back to best fit. Each closed compartment measures 5"W x 5 1/4"D x 10"H. Open space can accommodate most manufacturers' automatic hand sanitizer dispensers, hand sanitizer bottles, or wipe containers, sold separately.	HHC-PPESTND	39.0 	7.7	\$555	\$607	\$631
	Wall Mounted PPE Stand NOTES: Wall mounted. 3 closed compartments fit most manufacturers' boxed PPE, including gloves, masks, wipes, and tissues. Closed compartments have adjustable back to best fit. Each closed compartment measures 5"W x 5 1/4"D x 10"H. Open space can accommodate most manufacturers' automatic hand sanitizer dispensers, hand sanitizer bottles, or wipe containers, sold separately.	HHC-PPEWALL	14.0 	2.2	\$310	\$349	\$367
	 Model does not come equipped with wall mounted hardware.						

WORKPLACE TOOLS

HOW TO SPECIFY

Select Model Number HHC-SANSTND	Select Finish P8T
---	-----------------------------

HEALTHY WORKPLACE TOOLS

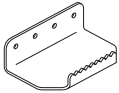

DESCRIPTION

Metal Foot Pull
5"W x 3¾"D x 1½"H

Pack of 5
Pack of 15

MODEL

HHC-FOOTPULL5
HHC-FOOTPULL15

SHIP WEIGHT

8
23

CUBE

0.7
0.7

LIST PRICE

\$321
\$900

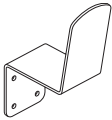

Metal Arm Pull
2½"W x 4½"D x 7½"H

Pack of 5
Pack of 15

HHC-ARMPULL5
HHC-ARMPULL15

8
23

0.7
0.7

\$321
\$900

NOTES:

- Pulls are made from 10-gauge steel.
- Mounting hardware included for attaching to steel and wood doors.
- Available in Textured Black and Textured Titanium.
- Available in 5-packs and 15-packs.

WORKPLACE TOOLS

HOW TO SPECIFY

Select Model Number

Select Finish

P6P Textured Black
P8V Textured Titanium

H H C - F O O T P U L L 5 . P 6 P

HEALTHY WORKPLACE TOOLS

Universal Screens

OPEN MARKET



Icon Legend on page 19

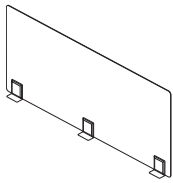

DESCRIPTION	MODEL	SHIP WEIGHT	CUBE	LIST PRICE BY PAINT GRADE			
				P1	P2	P3	P6
Metal Table Screen							
20"H x 45½"W, for 48"W Surfaces	HMTLSCRN2048	36.4	5.5	\$636	\$656	\$676	\$736
20"H x 51½"W, for 54"W Surfaces	HMTLSCRN2054	39.7	6.1	\$668	\$688	\$708	\$768
20"H x 57½"W, for 60"W Surfaces	HMTLSCRN2060	43.1	6.7	\$702	\$722	\$742	\$802
20"H x 63½"W, for 66"W Surfaces	HMTLSCRN2066	46.4	7.3	\$737	\$757	\$777	\$837
25"H x 45½"W, for 48"W Surfaces	HMTLSCRN2548	42.8	6.7	\$700	\$720	\$740	\$800
25"H x 51½"W, for 54"W Surfaces	HMTLSCRN2554	46.9	7.4	\$735	\$755	\$775	\$835
25"H x 57½"W, for 60"W Surfaces	HMTLSCRN2560	51.1	8.2	\$772	\$792	\$812	\$872
25"H x 63½"W, for 66"W Surfaces	HMTLSCRN2566	55.3	9.0	\$810	\$830	\$850	\$910

Acrylic Table Screen							
20"H x 45½"W, for 48"W Surfaces	HACRYSCRN2048	8.0	5.5	\$573	\$585	\$591	N/A
20"H x 51½"W, for 54"W Surfaces	HACRYSCRN2054	12.0	6.1	\$601	\$613	\$619	N/A
20"H x 57½"W, for 60"W Surfaces	HACRYSCRN2060	14.0	6.7	\$631	\$643	\$649	N/A
20"H x 63½"W, for 66"W Surfaces	HACRYSCRN2066	15.0	7.3	\$663	\$675	\$681	N/A
25"H x 45½"W, for 48"W Surfaces	HACRYSCRN2548	15.0	6.7	\$630	\$642	\$648	N/A
25"H x 51½"W, for 54"W Surfaces	HACRYSCRN2554	18.0	7.4	\$661	\$673	\$679	N/A
25"H x 57½"W, for 60"W Surfaces	HACRYSCRN2560	20.0	8.2	\$695	\$707	\$713	N/A
25"H x 63½"W, for 66"W Surfaces	HACRYSCRN2566	21.0	9.0	\$729	\$741	\$747	N/A

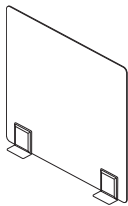

Metal Lateral Screen							
20"H x 21"D, for 24"D Surfaces	HMTLSCRN2024	19.5	3.0	\$440	\$460	\$480	\$540
20"H x 25"D, for 27"-30"D Surfaces	HMTLSCRN2030	21.6	3.4	\$462	\$482	\$502	\$562
20"H x 36"D, for 36"D Surfaces	HMTLSCRN2036	26.6	4.3	\$485	\$505	\$525	\$585
25"H x 21"D, for 24"D Surfaces	HMTLSCRN2524	22.4	3.7	\$484	\$504	\$524	\$584
25"H x 25"D, for 30"D Surfaces	HMTLSCRN2530	25.0	4.2	\$508	\$528	\$548	\$608
25"H x 34"D, for 36"D Surfaces	HMTLSCRN2536	31.3	5.3	\$534	\$554	\$574	\$634

Acrylic Lateral Screen							
20"H x 21"D, for 24"D Surfaces	HACRYSCRN2024	5.0	3.0	\$396	\$404	\$408	N/A
20"H x 25"D, for 27"-30"D Surfaces	HACRYSCRN2030	5.0	3.4	\$416	\$424	\$428	N/A
20"H x 36"D, for 36"D Surfaces	HACRYSCRN2036	6.0	4.3	\$437	\$445	\$449	N/A
25"H x 21"D, for 24"D Surfaces	HACRYSCRN2524	6.0	3.7	\$436	\$444	\$448	N/A
25"H x 25"D, for 30"D Surfaces	HACRYSCRN2530	8.0	4.2	\$457	\$465	\$469	N/A
25"H x 34"D, for 36"D Surfaces	HACRYSCRN2536	11.0	5.3	\$480	\$488	\$492	N/A

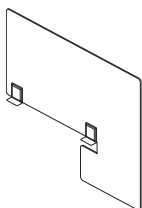

Metal Extended Screen							
20"H x 33½"D, for 24"D Surfaces	HMTLEXSCRN2036	61.2	5.7	\$585	\$605	\$625	\$685
20"H x 37"D, for 30"D Surfaces	HMTLEXSCRN2042	65.9	6.3	\$614	\$634	\$654	\$714
25"H x 33½"D, for 24"D Surfaces	HMTLEXSCRN2536	71.6	6.6	\$644	\$664	\$684	\$744
25"H x 37"D, for 30"D Surfaces	HMTLEXSCRN2542	77.4	7.3	\$676	\$696	\$716	\$776

Acrylic Extended Screen							
20"H x 33½"D, for 24"D Surfaces	HACRYEXSCRN2036	7.0	5.7	\$527	\$535	\$539	N/A
20"H x 37"D, for 30"D Surfaces	HACRYEXSCRN2042	9.0	6.3	\$553	\$561	\$565	N/A
25"H x 33½"D, for 24"D Surfaces	HACRYEXSCRN2536	12.0	6.6	\$579	\$587	\$591	N/A
25"H x 37"D, for 30"D Surfaces	HACRYEXSCRN2542	14.0	7.3	\$608	\$616	\$620	N/A

NOTES:

- Metal screens are single-piece steel construction.
- Screens mount by using double stick tape, which provides the ability to mount to any surface.
- Extended Screen can be used on all HON products including Voi®, Empower®, and Coordinate™ Height Adjustable Tables. Extended screen can also be used on any 2½" thick or under surface with 5"D clear space underneath.
- Minimum mounting clearance on top of worksurface at each bracket location is 3"W x 1½"D.

HOW TO SPECIFY

Select Model Number HMTLSCRN2054	Select Frame Paint Specify for Metal Screens only P8T	Select Bracket Paint NA No Specification Needed NA
--	--	---

WORKPLACE TOOLS



HEALTHY WORKPLACE TOOLS

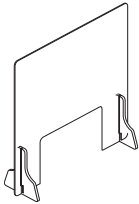

DESCRIPTION

Plexi-Glass Screens with Pass-Thru Opening

- 36”H x 30”W
- 36”H x 36”W
- 36”H x 48”W

MODEL

- HHC-TASCRN3630**
- HHC-TASCRN3636**
- HHC-TASCRN3648**

SHIP WEIGHT

- 13 Ⓢ
- 15 Ⓢ
- 19 Ⓢ

CUBE

- 1.4
- 1.1
- 1.5

LIST PRICE

- \$460**
- \$470**
- \$480**

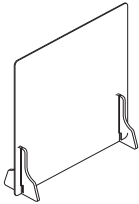

Plexi-Glass Screens without Pass-Thru Opening

- 24”H x 30”W
- 24”H x 36”W
- 24”H x 48”W

- H-TASCRN2430**
- H-TASCRN2436**
- H-TASCRN2448**

- 10 Ⓢ
- 11 Ⓢ
- 14 Ⓢ

- 1.0
- 1.2
- 1.6

- \$411**
- \$419**
- \$436**

- 36”H x 30”W
- 36”H x 36”W
- 36”H x 48”W

- H-TASCRN3630**
- H-TASCRN3636**
- H-TASCRN3648**

- 13 Ⓢ
- 15 Ⓢ
- 19 Ⓢ

- 1.4
- 1.1
- 1.5

- \$460**
- \$470**
- \$480**

NOTES:

- Screens ship with two black stands each.
- Screen stand is 11”D x 12”H.
- Pass-thru opening is 20”W x 12”H.

- ! Easy to assemble, no tools required.
- ! Unit is freestanding and does not need to be fixed to any surface.

WORKPLACE TOOLS

HOW TO SPECIFY

Select Model Number

HHC-TASCRN3636

HEALTHY WORKPLACE TOOLS

Universal Panel Stackers

OPEN MARKET



Icon Legend on page 19

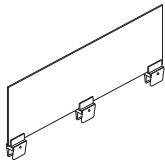

DESCRIPTION

Universal Panel Stackers

15"H x 22"W
15"H x 28"W
15"H x 34"W
15"H x 40"W
15"H x 46"W
15"H x 52"W
15"H x 58"W
15"H x 64"W
15"H x 70"W
15"H x 76"W
15"H x 82"W
15"H x 88"W
15"H x 94"W

MODEL	SHIP WEIGHT	CUBE	LIST PRICE BY PAINT GRADE		
			P1	P2	P3
HPNLSTACK1524	13.0	1.5	\$340	\$348	\$352
HPNLSTACK1530	15.0	1.8	\$380	\$388	\$392
HPNLSTACK1536	17.0	2.1	\$425	\$433	\$437
HPNLSTACK1542	19.0	2.5	\$470	\$482	\$488
HPNLSTACK1548	21.0	2.8	\$525	\$537	\$543
HPNLSTACK1554	24.0	3.2	\$550	\$562	\$568
HPNLSTACK1560	27.0	3.5	\$570	\$582	\$588
HPNLSTACK1566	29.0	3.9	\$660	\$676	\$684
HPNLSTACK1572	31.0	4.2	\$700	\$716	\$724
HPNLSTACK1578	34.0	4.6	\$740	\$756	\$764
HPNLSTACK1584	36.0	4.9	\$780	\$796	\$804
HPNLSTACK1590	38.0	5.3	\$850	\$870	\$880
HPNLSTACK1596	40.0	5.6	\$905	\$925	\$935
HPNLSTACK2224	17.0	1.9	\$384	\$392	\$396
HPNLSTACK2230	20.0	2.4	\$429	\$437	\$441
HPNLSTACK2236	23.0	2.9	\$480	\$488	\$492
HPNLSTACK2242	26.0	3.3	\$531	\$543	\$549
HPNLSTACK2248	29.0	3.8	\$593	\$605	\$611
HPNLSTACK2254	32.0	4.3	\$622	\$634	\$640
HPNLSTACK2260	35.0	4.7	\$644	\$656	\$662
HPNLSTACK2266	38.0	5.2	\$746	\$762	\$770
HPNLSTACK2272	41.0	5.6	\$791	\$807	\$815
HPNLSTACK2278	44.0	6.1	\$836	\$852	\$860
HPNLSTACK2284	47.0	6.6	\$881	\$897	\$905
HPNLSTACK2290	50.0	7.0	\$961	\$981	\$991
HPNLSTACK2296	53.0	7.5	\$1023	\$1043	\$1053

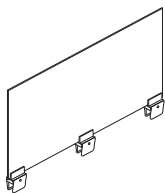

22"H x 22"W
22"H x 28"W
22"H x 34"W
22"H x 40"W
22"H x 46"W
22"H x 52"W
22"H x 58"W
22"H x 64"W
22"H x 70"W
22"H x 76"W
22"H x 82"W
22"H x 88"W
22"H x 94"W

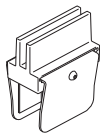

Universal Panel Stacker Bracket
1-Pack

HPNLSTACKBKT 2.5 1.0 \$120 \$124 \$126

NOTES:

- Can be used on any panel system between 1.975" and 3.450" thick.
- Glass is undersized by 2".
- Stackers can span multiple panels.
- Panel stackers will work with both flat trim and radius trim.



HOW TO SPECIFY

<p>Select Model Number</p> <p>HPNLSTACK2230</p>	<p>Select Glass</p> <p>G Glass</p> <p>G</p>	<p>Select Paint Color</p> <p>P</p>
<p>Select Model Number</p> <p>HPNLSTACKBKT</p>	<p>Select Paint Color</p> <p>P</p>	

WORKPLACE TOOLS

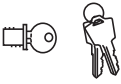
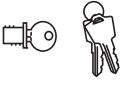
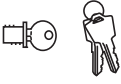

CORE REMOVABLE LOCK KITS

	DESCRIPTION	MODEL	SHIP WEIGHT	CUBE	LIST PRICE
 SIN 33721	Chrome Removable Lock Core Kit (for metal casegoods) • Use when specifying omit lock application. • Specify quantity of each key number from 101E-225E. • Includes: 1-core, 2-keys, 1-core removal tool and instructions. • Removable lock core kits with specific key number must be ordered to facilitate keying alike in the field. • For specific models, look for the Omit Lock Core icon throughout this publication. NOTES: If key number isn't specified, number will be at random. Core matches manufactured lock on metal casegoods product but can be used with Contain® and laminate product.	HF23C	0.1 Ⓞ	0.1	\$42
	Satin Removable Lock Core Kit (for metal and laminate casegoods) • Use when specifying omit lock application. • Specify quantity of each key number from 101E-225E. • Includes: 1-core, 2-keys, 1-core removal tool and instructions. • Removable lock core kits with specific key number must be ordered to facilitate keying alike in the field. • For specific models, look for the Omit Lock Core icon throughout this publication. NOTES: If key number isn't specified, number will be at random. Core matches manufactured lock on metal casegoods product but can be used with metal casegoods and laminate product. For laminate stack-on and wall mounted storage models with locks, use HF27S.	HF23S	0.1 Ⓞ	0.1	\$40
 SIN 33721	Black Removable Lock Core Kit (for laminate products) Specify quantity of each key number from 101E-225E. Includes: 1-core, 2-keys, 1-core removal tool, and instructions. NOTES: If key number isn't specified, number will be at random. Core matches manufactured lock on laminate product but can be used with metal casegoods product. For laminate stack-on and wall mounted storage models with locks, use HF27B.	HF23B	0.1 Ⓞ	0.1	\$32
	Removable Lock Core Kit Black Satin • For stack-on and wall mounted storage laminate models (with locks) in 10500, 10700, Valido, Voi, Concinnity, and 94000 Series. • Specify quantity of each key number from 101E to 225E. • Includes: 1-core, 2-keys, 1-core removal tool, and instructions. NOTES: If key number isn't specified, number will be at random.	HF27B HF27S	0.2 0.2	0.02 0.02	\$32 \$32
 OPEN MARKET	Master Key (one key) Will open all HON product with HON "One Key" interchangeable core removable locks. Available to authorized dealers only. Will open HF23B, HF23C, HF23S, HF24, HF27B, and HF27S locks numbered 101E-225E. Will open old HON style MB series locks.	HF22	0.1 Ⓞ	0.1	\$25
	Chrome Core Removable Lock Kit for Vertical Files Field Installable. Specify key number from 101E-225E. Includes: 1-lock with core, 2-keys and attaching linkage. NOTES: If key number isn't specified, number will be at random.	HF24	0.2 Ⓞ	0.2	\$58
 OPEN MARKET	Bulk Package 6 HF24 Lock Kits (Individually shrink wrapped) NOTES: Bulk Package key numbers are at random and cannot be specified.	HF246	1.2 Ⓞ	0.2	\$270

NOTES:

- HON "One Key" interchangeable core removable locks are standard on most HON products. Look for the HON "One Key" icon.
- Keyed alike cores are listed above.
- If key number is not specified, number will be at random.
- For keyed alike locks:
 - Order standard product which will be shipped with factory installed locks and random numbered cores or omit lock option where offered.
 - Order the appropriate quantity of like numbered cores required for each workstation or keyed area.
 - Simply replace the factory installed cores with the replacement cores after product has been installed.
- To install new core:
 - Lock must be in the unlocked position.
 - Insert core removal key and pull core straight out.
 - Insert new core with core removable key, hold core into lock and withdraw core removal key.
 - Retain original core for future use.
- To provide normal lead times, key numbers cannot be specified on HON products at time of order. This also eliminates need for tagging and tracking each product's lock number during installation.
- Black removable lock core kit used on laminate casegoods.
- Chrome removable lock core kit used on metal casegoods.



HOW TO ORDER CORE REMOVABLE LOCK KITS:

Specify: Model Number.X
Key Number
Examples: HF23C.X121E
HF23C.X (Key number not specified)

NOTES: Key orders without numbers specified will be keyed at random.
Numbers 101E-225E are available.

SAMPLE ORDER:

Quantity	Model	Key Code
6	HF23C.	X121E
4	HF23B.	X121E
5	HF24.	X121E
1	HF22.	X
2	HF24.	X

TOUCH-UP PAINT

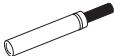

DESCRIPTION

MODEL

SHIP WEIGHT

CUBE

LIST PRICE BY PAINT GRADE

P1

P2

P3

1 Touch-up Paint (.6 oz.)

HPMARKER1

0.1

0.1

\$63

\$70

\$81

NOTES: Touch-up Paint available in P1, P2, and P3 colors.



Spray Paint (12 oz.)

HSPRAY

0.5

0.1

\$63

\$70

\$81

NOTES: Touch-up Paint available in P1, P2, and P3 colors.

Designer White Texture (PK7) for use with Solve base only.

NOTES:

- Allows minor repairs in the field.
- Shippable by small package carrier, ground only.
- Must specify color when ordering.

HOW TO SPECIFY

Select Model Number

Select Color

See page 801

HPMARKER1 . P

What is a Bundled Solution?

A bundled solution is comprised of several individual components and is ordered with a single, all-encompassing number (SKU).

Why Bundles?

With bundles, you identify one SKU rather than multiple models/SKUs. Order one SKU and get everything you need!

How do you order a bundle?

Get everything in this picture with one number.

Still Prefer Ordering Individual Components?

You can do that! See the "bundle components" section for individual item SKUs.

Contemporary U-Station SKU

VC7292U1B

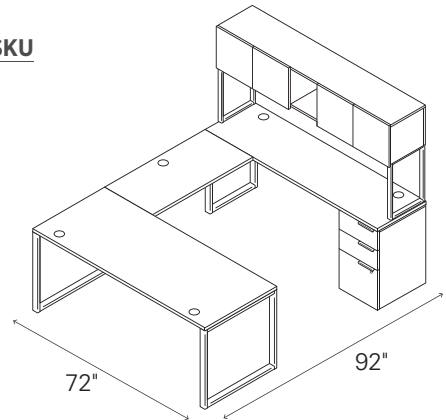

With this bundle you get the following components:

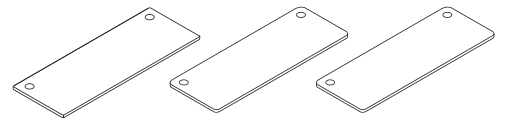

Rectangle Worksurfaces

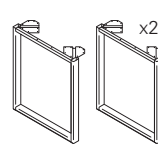

O-Leg Supports for Worksurfaces

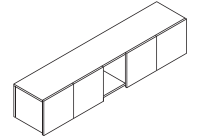

Overhead Cabinet with 4 Doors/Cubbie

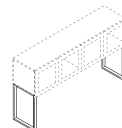

O-Leg Supports for Overhead Cabinet

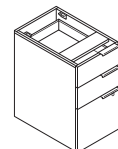

Support Pedestal

Availability

Specific bundle options are now available in the following HON Series:

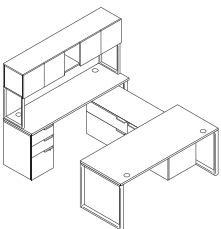

Voi

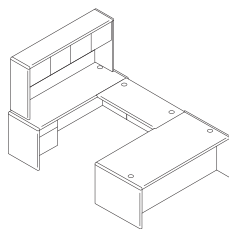

10700

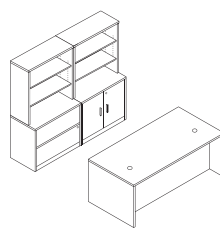

10500

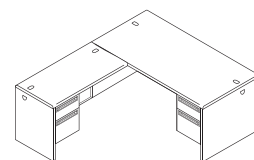

38000

VOI® Bundles Typicals

VT6030MB

Worksurface is Silver Mesh, Mobile Pedestal is Harvest, O-Leg Supports and grommets are Platinum Metallic.

QTY	DESCRIPTION	MODEL	LIST PRICE	PRICE EXTENSION
1	Rectangle Worksurface with External Support Channel	HLSLR3060W*	\$473	\$473
2	O-Leg Support for Worksurface	HLSL3028O	\$352	\$704
1	Mobile Pedestal	HLSL2016MP2	\$794	\$794
TOTAL:			\$1,971	

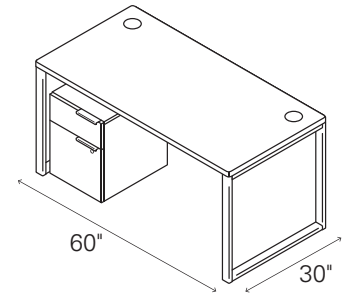
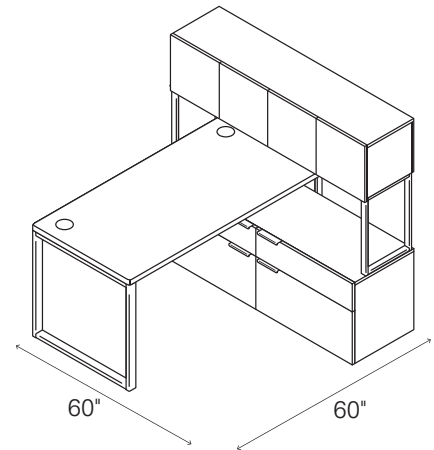

**TABLE DESK WITH MOBILE PEDESTAL
(NON-HANDED)**

VS6060L1B

Worksurface is Silver Mesh, Low Credenza and Overhead Cabinet are Harvest, O-Leg Supports and grommets are Platinum Metallic.

QTY	DESCRIPTION	MODEL	LIST PRICE	PRICE EXTENSION
1	Rectangle Worksurface with External Support Channel	HLSLR3060W*	\$473	\$473
2	O-Leg Support for Worksurface	HLSL3028O	\$352	\$704
1	Low Credenza, 2 File/2 Box	HLSL2060LD4	\$1,462	\$1,462
1	Overhead Cabinet with 4 Doors	HLSL1460D	\$1,161	\$1,161
1	O-Leg Support for Overhead Cabinet (Pair)	HLSL650S	\$472	\$472
TOTAL:			\$4,272	



**SMALL FOOTPRINT L-STATION
(NON-HANDED)**

VS6060L6B

Worksurface is Silver Mesh, Low Credenza and Layering Shelf are Harvest, O-Leg Supports and grommets are Platinum Metallic.

QTY	DESCRIPTION	MODEL	LIST PRICE	PRICE EXTENSION
1	Rectangle Worksurface with External Support Channel	HLSLR3060W*	\$473	\$473
2	O-Leg Support for Worksurface	HLSL3028O	\$352	\$704
1	Low Credenza, Right-hand Drawers	HLSL2060LR2	\$1,254	\$1,254
1	Layering Shelf	HLSL1460LS	\$364	\$364
TOTAL:			\$2,795	

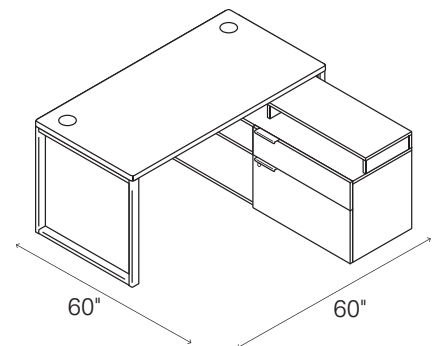

**SMALL FOOTPRINT L-STATION
(RIGHT HANDED, LOW CREDENZA)**

*Worksurface model **HLSLR3060W** can only be ordered with bundles.

VS6060L4B

Worksurface is Silver Mesh, Low Credenza and Layering Shelf are Harvest, O-Leg Supports and grommets are Platinum Metallic.

QTY	DESCRIPTION	MODEL	LIST PRICE	PRICE EXTENSION
1	Rectangle Worksurface with External Support Channel	HLSLR3060W*	\$473	\$473
2	O-Leg Support for Worksurface	HLSL30280	\$352	\$704
1	Low Credenza, Left-hand Drawers	HLSL2060LL2	\$1,254	\$1,254
1	Layering Shelf	HLSL1460LS	\$364	\$364
TOTAL:			\$2,795	

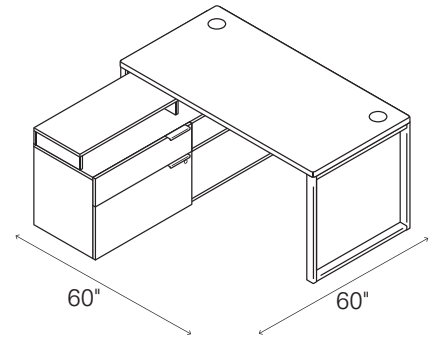

**SMALL FOOTPRINT L-STATION
(LEFT HANDED, LOW CREDENZA)**

VS6060L5B

Worksurface is Silver Mesh, Low Credenza and Overhead Cabinet are Harvest, O-Leg Supports and grommets are Platinum Metallic.

QTY	DESCRIPTION	MODEL	LIST PRICE	PRICE EXTENSION
1	Rectangle Worksurface with External Support Channel	HLSLR3060W*	\$473	\$473
2	O-Leg Support for Worksurface	HLSL30280	\$352	\$704
1	Low Credenza, Right-hand Drawers	HLSL2060LR2	\$1,254	\$1,254
1	Overhead Cabinet with 4 Doors	HLSL1460D	\$1,161	\$1,161
1	O-Leg Support for Overhead Cabinet (Pair)	HLSL650S	\$472	\$472
TOTAL:			\$4,064	

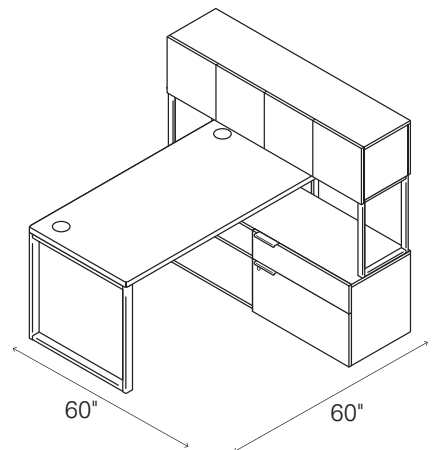

**SMALL FOOTPRINT L-STATION
(RIGHT HANDED, LOW CREDENZA)**

VS6060L3B

Worksurface is Silver Mesh, Low Credenza and Overhead Cabinet are Harvest, O-Leg Supports and grommets are Platinum Metallic.

QTY	DESCRIPTION	MODEL	LIST PRICE	PRICE EXTENSION
1	Rectangle Worksurface with External Support Channel	HLSLR3060W*	\$473	\$473
2	O-Leg Support for Worksurface	HLSL30280	\$352	\$704
1	Low Credenza, Left-hand Drawers	HLSL2060LL2	\$1,254	\$1,254
1	Overhead Cabinet with 4 Doors	HLSL1460D	\$1,161	\$1,161
1	O-Leg Support for Overhead Cabinet (Pair)	HLSL650S	\$472	\$472
TOTAL:			\$4,064	

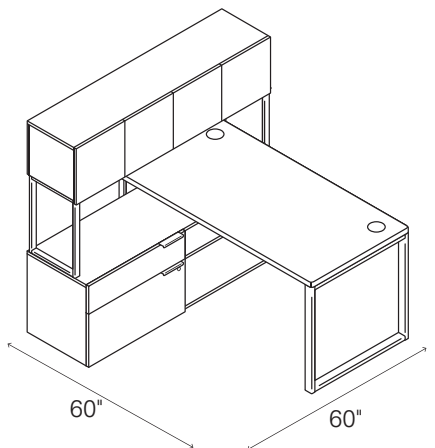

**SMALL FOOTPRINT L-STATION
(LEFT HANDED, LOW CREDENZA)**

*Worksurface model **HLSLR3060W** can only be ordered with bundles.

VOI® Bundles Typical

VS6060L2B

Worksurface is Silver Mesh, Low Credenza and Layering Shelf are Harvest, O-Leg Supports and grommets are Platinum Metallic.

QTY	DESCRIPTION	MODEL	LIST PRICE	PRICE EXTENSION
1	Rectangle Worksurface with External Support Channel	HLSLR3060W*	\$473	\$473
2	O-Leg Support for Worksurface	HL30280	\$352	\$704
1	Low Credenza, 2 File/2 Box	HLSL2060LD4	\$1,462	\$1,462
1	Layering Shelf	HLSL1460LS	\$364	\$364
TOTAL:			\$3,003	

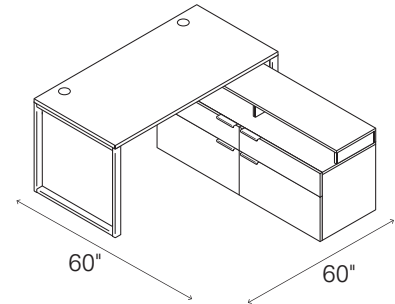

**SMALL FOOTPRINT L-STATION
(LOW CREDENZA, LAYERING SHELF)
(NON-HANDED)**

VC7260L2B

Worksurface is Silver Mesh, Low Credenza is Harvest, O-Leg Supports and grommets are Platinum Metallic.

QTY	DESCRIPTION	MODEL	LIST PRICE	PRICE EXTENSION
1	Rectangle Worksurface with External Support Channel	HLSLR3072W*	\$551	\$551
2	O-Leg Support for Worksurface	HL30280	\$352	\$704
1	Low Credenza, 2 File/2 Box	HLSL2060LD4	\$1,462	\$1,462
TOTAL:			\$2,717	

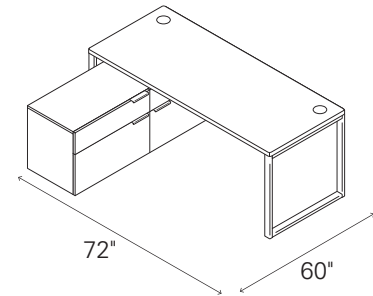

**CONTEMPORARY L-STATION
(NON-HANDED)**

*Worksurface models HLSLR3060W and HLSLR3072W can only be ordered with bundles.

10500 SERIES™ Bundles Typical

Mahogany
H105LL7284N

Harvest
H105LL7284C

QTY	DESCRIPTION	MODEL	LIST PRICE	PRICE EXTENSION
1	Left Pedestal Desk	H10586L	\$1,182	\$1,182
1	Right Return	H10515R	\$837	\$837
TOTAL:			\$2,019	

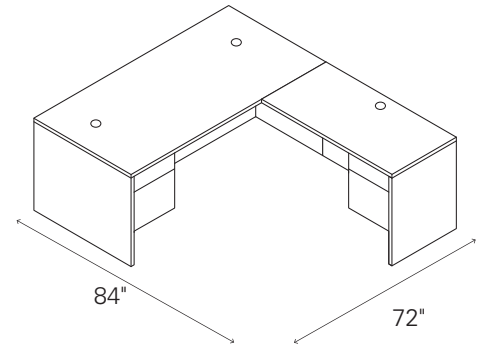

L-STATION (LEFT DESK/RIGHT RETURN)

Mahogany
H105LR7284N

Harvest
H105LR7284C

QTY	DESCRIPTION	MODEL	LIST PRICE	PRICE EXTENSION
1	Right Pedestal Desk	H10585R	\$1,182	\$1,182
1	Left Return	H10516L	\$837	\$837
TOTAL:			\$2,019	

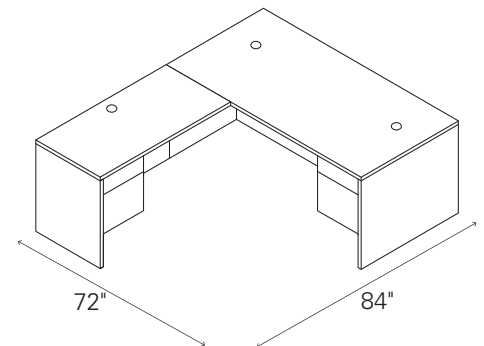

L-STATION (RIGHT DESK/LEFT RETURN)

Mahogany
H105LLH7284N

Harvest
H105LLH7284C

QTY	DESCRIPTION	MODEL	LIST PRICE	PRICE EXTENSION
1	Left Pedestal Desk	H10586L	\$1,182	\$1,182
1	Right Return	H10515R	\$837	\$837
1	Stack-on Storage	H105323	\$850	\$850
TOTAL:			\$2,869	

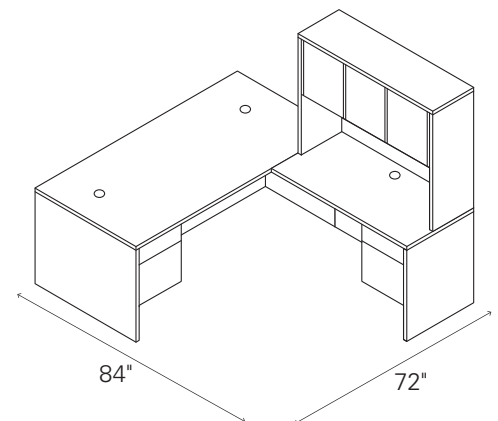

**L-STATION WITH STACK-ON STORAGE
(LEFT DESK/RIGHT RETURN)**

BUNDLES

10500 SERIES™ Bundles Typical

Mahogany
H105LRH7284N

Harvest
H105LRH7284C

QTY	DESCRIPTION	MODEL	LIST PRICE	PRICE EXTENSION
1	Right Pedestal Desk	H10585R	\$1,182	\$1,182
1	Left Return	H10516L	\$837	\$837
1	Stack-on Storage	H105323	\$850	\$850
TOTAL:			\$2,869	

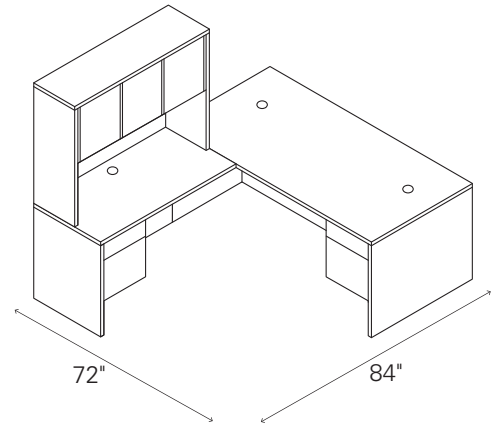

**L-STATION WITH STACK-ON STORAGE
(RIGHT DESK/LEFT RETURN)**

Mahogany
H105ULH72108N

Harvest
H105ULH72108C

QTY	DESCRIPTION	MODEL	LIST PRICE	PRICE EXTENSION
1	Left Pedestal Desk	H10586L	\$1,182	\$1,182
1	Right Pedestal Credenza	H10545R	\$1,023	\$1,023
1	Bridge	H10570	\$364	\$364
1	Stack-on Storage	H10534	\$1,011	\$1,011
TOTAL:			\$3,580	

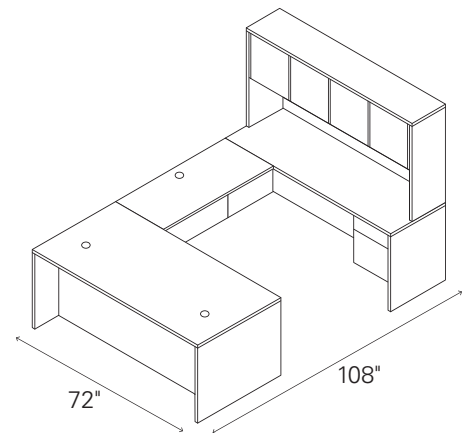

**U-STATION WITH STACK-ON STORAGE
(LEFT DESK/RIGHT CREDEENZA)**

Mahogany
H105URH72108N

Harvest
H105URH72108C

QTY	DESCRIPTION	MODEL	LIST PRICE	PRICE EXTENSION
1	Right Pedestal Desk	H10585R	\$1,182	\$1,182
1	Left Pedestal Credenza	H10546L	\$1,023	\$1,023
1	Bridge	H10570	\$364	\$364
1	Stack-on Storage	H10534	\$1,011	\$1,011
TOTAL:			\$3,580	

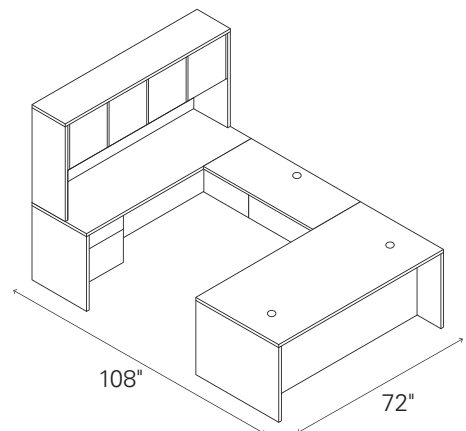

**U-STATION WITH STACK-ON STORAGE
(RIGHT DESK/LEFT CREDEENZA)**

10500 SERIES™ Bundles Typicals

Mahogany
H105DLH7298N

Harvest
H105DLH7298C

QTY	DESCRIPTION	MODEL	LIST PRICE	PRICE EXTENSION
1	Double Pedestal Desk	H10593	\$1,391	\$1,391
2	Bookcase Hutch	H105292	\$570	\$1,140
1	2-Drawer Lateral File	H10563	\$973	\$973
1	Storage Cabinet with Doors	H105291	\$781	\$781
TOTAL:			\$4,285	

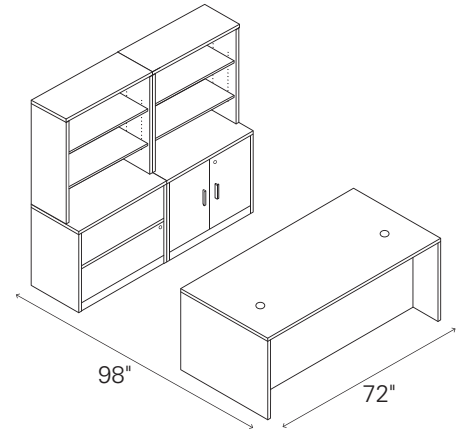

STORAGE WORKSTATION

Mahogany
H105DCH6098N

Harvest
H105DCH6098C

QTY	DESCRIPTION	MODEL	LIST PRICE	PRICE EXTENSION
1	Double Pedestal Desk	H10573	\$1,172	\$1,172
1	Double Pedestal Credenza	H10565	\$1,172	\$1,172
1	Stack-on Storage	H105324	\$943	\$943
TOTAL:			\$3,287	

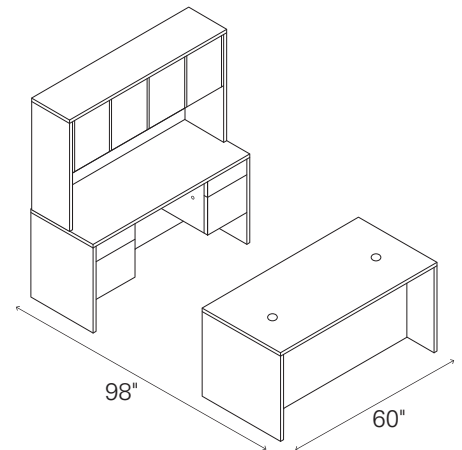

DESK CREDENZA STACK-ON #1

Mahogany
H105DCH7298N

Harvest
H105DCH7298C

QTY	DESCRIPTION	MODEL	LIST PRICE	PRICE EXTENSION
1	Double Pedestal Desk	H10593	\$1,391	\$1,391
1	Double Pedestal Credenza	H10543	\$1,240	\$1,240
1	Stack-on Storage	H10534	\$1,011	\$1,011
TOTAL:			\$3,642	

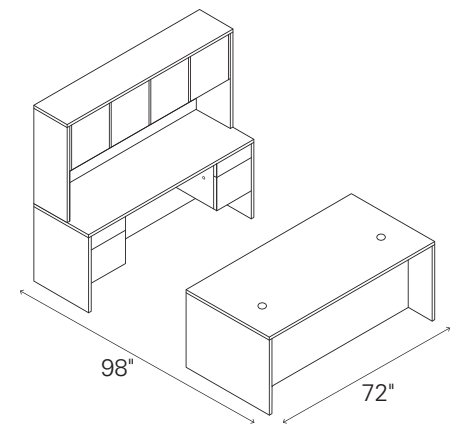

DESK CREDENZA STACK-ON #2

BUNDLES

10700 SERIES™ Bundles Typicals

Mahogany
H107LL7284N

QTY	DESCRIPTION	MODEL	LIST PRICE	PRICE EXTENSION
1	Left Pedestal Desk	H10786L	\$1,346	\$1,346
1	Right Return	H10715R	\$905	\$905
TOTAL:			\$2,251	

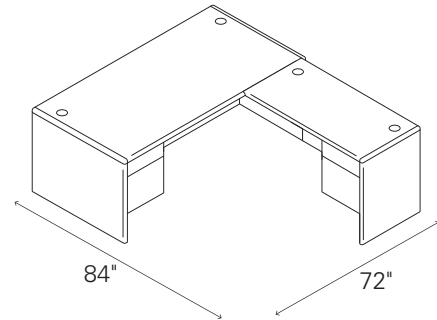

L-STATION (LEFT DESK, RIGHT RETURN)

Mahogany
H107LR7284N

QTY	DESCRIPTION	MODEL	LIST PRICE	PRICE EXTENSION
1	Right Pedestal Desk	H10785R	\$1,346	\$1,346
1	Left Return	H10716L	\$905	\$905
TOTAL:			\$2,251	

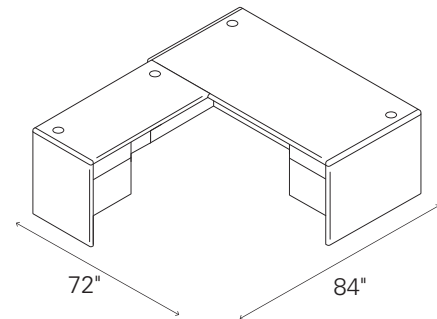

L-STATION (RIGHT DESK, LEFT RETURN)

Mahogany
H107UL72108N

QTY	DESCRIPTION	MODEL	LIST PRICE	PRICE EXTENSION
1	Left Pedestal Desk	H10786L	\$1,346	\$1,346
1	Right Pedestal Credenza	H10745R	\$1,181	\$1,181
1	Bridge	H10770	\$409	\$409
TOTAL:			\$2,936	

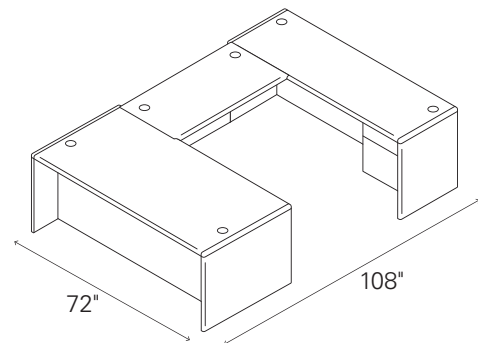

U-STATION (LEFT DESK, RIGHT CREDENZA)

10700 SERIES™ Bundles Typicals

Mahogany
H107UR72108N

QTY	DESCRIPTION	MODEL	LIST PRICE	PRICE EXTENSION
1	Right Pedestal Desk	H10785R	\$1,346	\$1,346
1	Left Pedestal Credenza	H10746L	\$1,181	\$1,181
1	Bridge	H10770	\$409	\$409
TOTAL:			\$2,936	

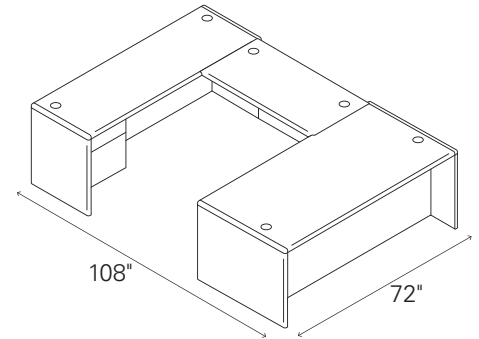

U-STATION (RIGHT DESK, LEFT CREDENZA)

Mahogany
H107LLH7284N

QTY	DESCRIPTION	MODEL	LIST PRICE	PRICE EXTENSION
1	Left Pedestal Desk	H10786L	\$1,346	\$1,346
1	Right Return	H10715R	\$905	\$905
1	Stack-on Storage	H107313	\$1,067	\$1,067
TOTAL:			\$3,318	

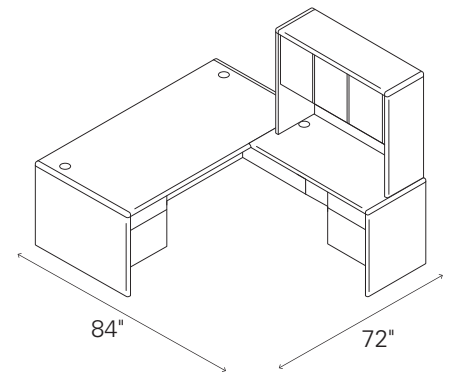

**L-STATION WITH STACK-ON STORAGE
(LEFT DESK, RIGHT RETURN)**

Mahogany
H107LRH7284N

QTY	DESCRIPTION	MODEL	LIST PRICE	PRICE EXTENSION
1	Right Pedestal Desk	H10785R	\$1,346	\$1,346
1	Left Return	H10716L	\$905	\$905
1	Stack-on Storage	H107313	\$1,067	\$1,067
TOTAL:			\$3,318	

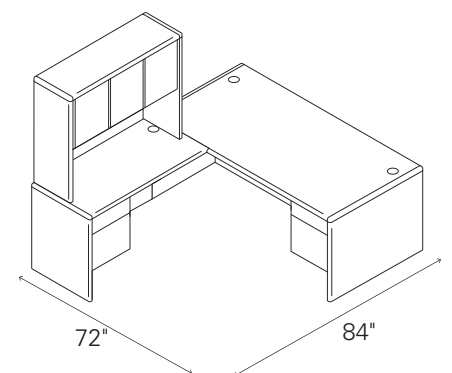

**L-STATION WITH STACK-ON STORAGE
(RIGHT DESK, LEFT RETURN)**

10700 SERIES™ Bundles Typicals

Mahogany
H107ULH72108N

QTY	DESCRIPTION	MODEL	LIST PRICE	PRICE EXTENSION
1	Left Pedestal Desk	H10786L	\$1,346	\$1,346
1	Right Pedestal Credenza	H10745R	\$1,181	\$1,181
1	Bridge	H10770	\$409	\$409
1	Stack-on Storage	H10734	\$1,211	\$1,211
TOTAL:			\$4,147	

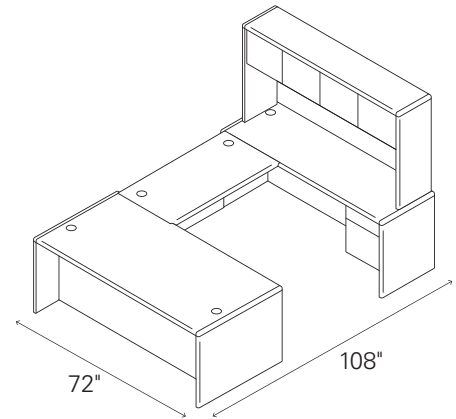

**U-STATION WITH STACK-ON STORAGE
(LEFT DESK, RIGHT CREDENZA)**

Mahogany
H107URH72108N

QTY	DESCRIPTION	MODEL	LIST PRICE	PRICE EXTENSION
1	Right Pedestal Desk	H10785R	\$1,346	\$1,346
1	Left Pedestal Credenza	H10746L	\$1,181	\$1,181
1	Bridge	H10770	\$409	\$409
1	Stack-on Storage	H10734	\$1,211	\$1,211
TOTAL:			\$4,147	

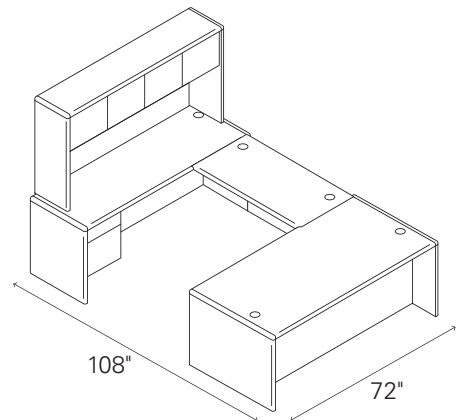

**U-STATION WITH STACK-ON STORAGE
(RIGHT DESK, LEFT CREDENZA)**

38000 SERIES™ Bundles Typicals

Mahogany/Charcoal
H38LL7284NS

Harvest/Putty
H38LL7284CL

QTY	DESCRIPTION	MODEL	LIST PRICE	PRICE EXTENSION
1	Left Pedestal Desk	H38294L	\$1,721	\$1,721
1	Right Return	H38215R	\$1,041	\$1,041
TOTAL:			\$2,762	

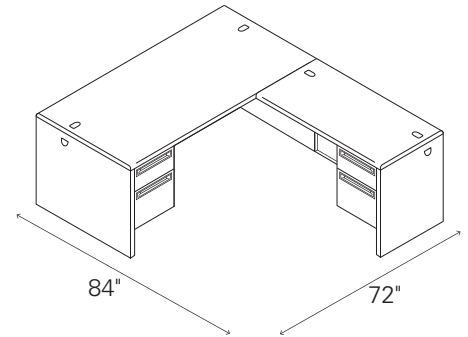

L-STATION (LEFT DESK/RIGHT RETURN)

Mahogany/Charcoal
H38LR7284NS

Harvest/Putty
H38LR7284CL

QTY	DESCRIPTION	MODEL	LIST PRICE	PRICE EXTENSION
1	Right Pedestal Desk	H38293R	\$1,721	\$1,721
1	Left Return	H38216L	\$1,041	\$1,041
TOTAL:			\$2,762	

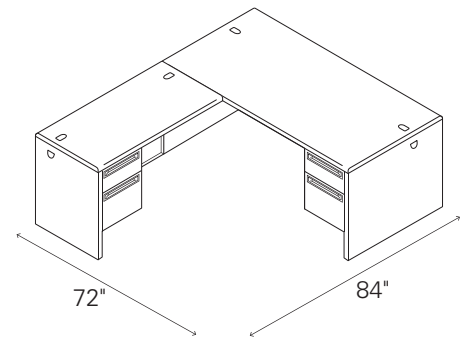

L-STATION (RIGHT DESK/LEFT RETURN)

Mahogany/Charcoal
H38URH72108NS2

Harvest/Putty
H38URH72108CL2

QTY	DESCRIPTION	MODEL	LIST PRICE	PRICE EXTENSION
1	Single Pedestal Desk, Right	H38293R	\$1,721	\$1,721
1	Single Pedestal Credenza, Left	H38855L	\$1,428	\$1,428
1	Hutch without Doors	H386572N	\$908	\$908
1	Flipper Doors, Pair	H387215	\$564	\$564
1	Bridge	H38210	\$579	\$579
TOTAL:			\$5,200	

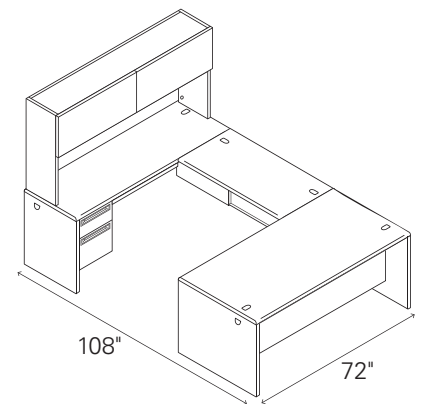

**U-STATION WITH HUTCH
(RIGHT DESK/LEFT CREDENZA)**

38000 SERIES™

Bundles Typical

Mahogany/Charcoal
H38ULH72108NS2

Harvest/Putty
H38ULH72108CL2

QTY	DESCRIPTION	MODEL	LIST PRICE	PRICE EXTENSION
1	Single Pedestal Desk, Left	H38294L	\$1,721	\$1,721
1	Single Pedestal Credenza, Right	H38856R	\$1,428	\$1,428
1	Hutch without Doors	H386572N	\$908	\$908
1	Flipper Doors, Pair	H387215	\$564	\$564
1	Bridge	H38210	\$579	\$579
TOTAL:			\$5,200	

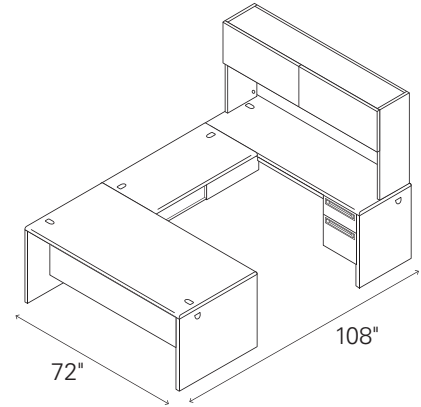

**U-STATION WITH HUTCH
 (LEFT DESK/RIGHT CREDENZA)**

Mahogany/Charcoal
H38DCH6096NS2

Harvest/Putty
H38DCH6096CL2

QTY	DESCRIPTION	MODEL	LIST PRICE	PRICE EXTENSION
1	Double Pedestal Desk	H38155	\$1,650	\$1,650
1	Double Pedestal Credenza	H38852	\$1,611	\$1,611
1	Hutch without Doors	H386560N	\$798	\$798
1	Flipper Doors, Pair	H386015	\$531	\$531
TOTAL:			\$4,590	

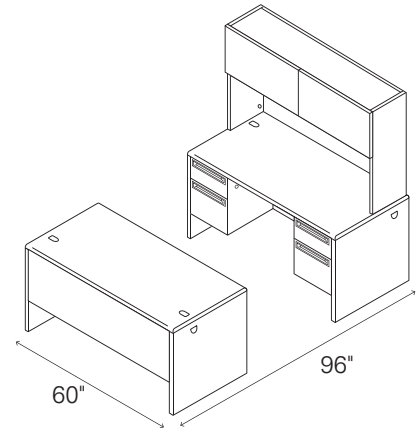

WORKSTATION

CROSS REFERENCE INDEX

MODEL	PAGE	MODEL	PAGE	MODEL	PAGE	MODEL	PAGE
H10501	258, 304	H105321K	269	H105491	267	H105810	275
H105012	258	H105322	269	H105492	267	H105811	275
H105014	259	H105322G	270	H105493	267	H105815R	275
H10502	258, 304	H105322K	269	H105520	279	H105816L	275
H10503	260, 305	H105323	269	H105523	279	H105817R	275
H10504	259, 304	H105323G	270	H105524	279	H105818L	275
H10505	260, 305	H105323K	269	H105525R	279	H10583R	263
H105062	258	H105324	269	H105526L	279	H10584L	263
H105064	259	H105324G	270	H105527R	279	H105851	155, 272
H105076	260	H105324K	269	H105528L	279	H105852	155, 272
H105077	260	H105327	269	H105531	277	H105853	155, 272
H10508	260, 305	H105327G	270	H105532	279, 683	H105854	155, 272
H105093	258, 304	H105327K	269	H105533	279, 683	H105855	155, 272
H105098	142, 245, 301	H10533	269	H105534	279, 683	H105856	155, 272
H105099	142, 245, 301	H10533G	270	H105535	279, 683	H105857	155, 272
H1050CST	679	H10533K	269	H105581	245	H10585R	263
H105102	276, 314	H10534	269	H105581X	245	H10586L	263
H105104	276, 314	H105349	154, 270	H105582	245	H10587R	263
H105106	276, 314	H10534G	270	H105582X	245	H105885R	263
H105109	276, 314	H10534K	269	H105583	245	H10588L	263
H10511R	263	H10536	268	H105583X	245	H105890	261
H10512L	263	H105360	274	H105598	267	H105891	261
H10515R	263	H105361	274	H105599	267	H105892	261
H10516	276	H105362	274	H10560	267	H105893R	261
H10516L	263	H105363	274	H10561	248	H105894L	261
H10517	276	H105367	268	H10561X	248	H105895R	261
H105201R	265	H105368	268	H10563	276	H105896L	261
H105202L	265	H10537	268	H10564	245	H105897R	261
H105203R	265	H105380	273	H10564X	245	H105898L	261
H105204L	265	H105380G	274	H10565	264	H105899	261
H105205R	266	H105380K	273	H10566	264	H105900	262
H105206L	266	H105381	273	H105663	247	H105901	262
H105209	265	H105381G	274	H105679	145, 260, 305	H105902	262
H10521	265	H105381K	273	H10568	248	H105903R	262
H10522	265	H105382	273	H10568X	248	H105904L	262
H10523	265	H105382G	274	H105680	248	H105905R	262
H10524	259, 304	H105382K	273	H105680X	248	H105906L	262
H1052441LEP	250	H105383	273	H105681	248	H105907R	262
H10524LEP	250	H105383G	274	H105681X	248	H105908L	262
H10524TEP	250	H105383K	273	H105684	248	H105909	262
H10524TSUPP	250	H105386	268	H105684X	248	H10592	244
H10525R	265	H105388	268	H105686	248	H10592X	244
H10526L	265	H105392	247	H105686X	248	H10593	263
H10528	151, 266, 310	H105393	247	H105690	276	H10594	244
H105290	277	H105397	247	H105691	245	H10594X	244
H105291	277	H10541	245	H105691X	245	H10595	263
H105292	277	H105410	246	H105692	245	H10596	244
H105293	278	H105410X	246	H105692X	245	H10596X	244
H105295R	278	H105411	246	H105698	267	H105973R	262
H105296L	278	H105411X	246	H105699	267	H105974L	262
H105297R	278	H105412	246	H10570	267	H105975R	262
H105298L	278	H105412X	246	H10571	263	H105976L	262
H105299	278	H105413	246	H105720	280	H10598	244
H10530	278	H105413X	246	H105721	160, 280	H10598X	244
H105301R	278	H10541X	245	H105722	160, 280	H105B2460	249
H105302L	278	H10542	245	H105724	280	H105B3060	249
H1053041LEP	250	H10542X	245	H105726	280	H105B3066	249
H10530LEP	250	H10543	264	H105729	280	H105B3072	249
H10530TEP	250	H10544	264	H10573	263	H105R2430	249
H105310	277	H10545R	264	H10578	244	H105R2436	249
H105319	271	H10546L	264	H10578X	244	H105R2442	249, 254
H105321	269	H10547R	267	H10579	244	H105R2448	249, 254, 585, 720
H105321G	270	H10548L	267	H10579X	244	H105R2460	249, 254, 585, 720

CROSS REFERENCE INDEX

MODEL	PAGE	MODEL	PAGE	MODEL	PAGE	MODEL	PAGE
H105R2466	249, 254, 585, 720	H10742	307	H107825	300	H115322	153
H105R2472	249, 254, 585, 720	H10743	309	H107825X	300	H115322G	154
H105R2478	249	H10744	309	H107826	300	H115322K	153
H105R2484	249	H10745R	309	H107827	300	H115323	153
H105R3048	249, 254, 585, 720	H10746L	309	H107829	300	H115323G	154
H105R3060	249, 254, 585, 720	H10747R	311	H107835	301	H115323K	153
H105R3066	249, 254, 585, 720	H10748L	311	H107836	301	H115324	153
H105R3072	249, 254, 585, 720	H107492	311	H107837	301	H115324G	154
H105R3078	249	H10751	311	H10783R	308	H115324K	153
H105R3084	249	H10752	315	H10784L	308	H115327	153
H105T2430C	266	H10753	315	H10785R	308	H115327G	154
H105T3036C	266	H10754	315	H10786L	308	H115327K	153
H10701R	306	H10755	315	H10787R	306	H11533	153
H10702L	306	H107569	315	H10787RG	306	H11533G	154
H10705R	307	H10760	311	H107885R	308	H11533K	153
H10706L	307	H10762	314	H10788L	306	H11534	153
H10707R	307	H10763R	309	H10788LG	306	H11534G	154
H10708L	307	H10764L	309	H10791	308	H11534K	153
H10709R	307	H10765	309	H10799	306	H115380	155
H10710L	307	H10766	309	H10799G	306	H115380K	155
H10711R	307	H10767	307	H11501	144	H115381	155
H10712L	307	H10768	307	H115012	144	H115381K	155
H10715R	309	H107690	314	H115014	144	H115382	155
H10716L	309	H107698	314	H11502	144	H115382K	155
H10717R	309	H107699	314	H11503	145	H115383	155
H10718L	309	H10770	311	H11504	144	H115383K	155
H107191R	307	H10771	308	H11505	145	H11541	142
H107192L	307	H107720	317	H11508	145	H11541X	142
H107193R	309	H107721R	317	H115093	144	H11542	142
H107194L	309	H107722L	317	H115102	157	H11542X	142
H10721	310	H107725R	302	H115104	157	H11543	149
H10722	310	H107726L	302	H115106	157	H11544	149
H107242	317	H107727R	302	H115109	157	H11545R	149
H107270X	303	H107727RX	303	H11511R	148	H11546L	149
H107290	314	H107728L	302	H11512L	148	H11547R	152
H107291	314	H107728LX	303	H11515R	148	H11548L	152
H107292	314	H10773	306	H11516	157	H115491	152
H107293	316	H10774	306	H11516L	148	H115492	152
H107295R	316	H10775	308	H11517	157	H115493	152
H107296L	316	H107801R	302	H115201R	150	H11552	159
H107299	316	H107801RX	303	H115202L	150	H115520	159
H10730	316	H107802L	302	H115203R	150	H115523	159
H107301R	316	H107802LX	303	H115204L	150	H115524	159
H107302L	316	H107803R	302	H11521	150	H115525R	159
H107313	312	H107803RX	303	H11522	150	H115526L	159
H107313K	312	H107804L	302	H11523	150	H115527R	159
H107318	312	H107804LX	303	H11525R	150	H115528L	159
H107318K	312	H107805R	302	H11526L	150	H11553	159
H10732	312	H107805RX	303	H115290	157	H11554	159
H10732K	312	H107806L	302	H115291	157	H11555	159
H10733	312	H107806LX	303	H115292	157	H115581	142
H10733K	312	H107807R	302	H115293	158	H115581X	142
H10734	312	H107807RX	303	H115295R	158	H115582	142
H10734G	312	H107808L	302	H115296L	158	H115582X	142
H10734K	312	H107808LX	303	H115297R	158	H115583	142
H107353	313	H107811	311	H115298L	158	H115583X	142
H107358	313, 331	H107815	301	H115299	158	H115598	152
H10736	313	H107815X	301	H11530	158	H115599	152
H10737	313	H107816	301	H115301R	158	H11560	152
H10738	313, 331	H107816X	301	H115302L	158	H11561	143
H107398	311	H107817	301	H115321	153	H11561X	143
H107399	311	H107817X	301	H115321G	154	H11563	157
H10741	307	H107824	300	H115321K	153	H11564	142

CROSS REFERENCE INDEX

MODEL	PAGE	MODEL	PAGE	MODEL	PAGE	MODEL	PAGE
H11564X	142	H11598	141	H38170	367	H512C	675
H11565	149	H14917(?)	652	H38180	367	H514	675
H11566	149	H14923(?)	652	H38210	369	H514C	675
H11568	143	H1522	106, 161, 227, 282, 320, 333, 832	H38215R	367	H519495	348, 356, 369, 679
H115680	143	H1526	106, 161, 227, 282, 320, 333, 832	H38216L	367	H52	660
H115680X	143	H15923(?)	530, 653	H38217R	367	H5210	826
H115681	143	H1706	114, 161, 225, 288, 321, 334, 341, 351, 356, 601, 829	H38218L	367	H5220	825
H115681X	143			H38220	369	H52C	660
H115684	143	H1801	684	H38251	367	H54	660
H115684X	143	H1871	684	H38252L	367	H54C	660
H115686	143	H18717(?)	652	H38291R	367	H66280	794
H115686X	143	H1872	684	H38292L	367	H66282	794
H11568X	143	H18723(?)	652	H38293R	367	H66531	794
H115690	157	H18730(?)	652	H38294L	367	H66537	794
H115691	142	H1874	684	H384815	374	H66541	794
H115691X	142	H1875	684	H386015	374	H66547	794
H115692	142	H1876	684	H386548N	348, 374	H66551	794
H115692X	142	H1877	684	H386560N	348, 374	H66557	794
H115698	152	H18817(?)	652	H386566N	348, 374	H66571	794
H115699	152	H18823(?)	652	H386572N	374	H66577	794
H11570	152	H18830(?)	652	H386615	374	H66581	794
H11571	148	H19717(?)	652	H387215	374	H66582	794
H115720	160	H19723(?)	652	H38851	367	H66591	794
H115724	160	H19730(?)	652	H38852	367	H66597	794
H115726	160	H19817(?)	652	H38853	367	H672	620
H11573	148	H19823(?)	652	H38854	367	H673	620
H11578	141	H19830(?)	652	H38855L	367	H674	620
H11579	141	H20040AG	679	H38856R	367	H675	620
H115811	156	H2107	114, 161, 225, 288, 321, 334, 341, 351, 356, 601, 829	H38857L	367	H682	620
H115815R	156			H38858R	367	H683	620
H115816L	156	H212	673	H38921	368	H684	620
H11583R	148	H212C	673	H38922	368	H685	620
H11584L	148	H214	673	H38923	368	H692	620
H11585R	148	H214C	673	H38925	368	H693	620
H11586L	148	H215	673	H38928	369	H694	620
H11587R	148	H215C	673	H38931	368	H695	620
H115885R	148	H2516	114, 161, 225, 288, 321, 334, 341, 351, 356, 601, 829	H38932	368	H772	618
H11588L	148			H38933	368	H773	618
H115890	146	H312	674	H38934	368	H774	618
H115891	146	H312C	674	H38935	368	H775	618
H115892	146	H314	674	H38941	369	H775LS	619
H115893R	146	H314C	674	H38942	369	H782	618
H115894L	146	H315	674	H38943R	368	H783	618
H115895R	146	H315C	674	H38944L	368	H784	618
H115896L	146	H32	660	H38945R	368	H785	618
H115897R	146	H33720(?)	615	H38946L	368	H785LS	619
H115898L	146	H33723(?)	615	H38947R	368	H792	618
H115899	146	H33820(?)	615	H38948L	368	H793	618
H115900	147	H33823(?)	615	H38949R	368	H794	618
H115901	147	H34	660	H38950L	368	H795	618
H115902	147	H34002R	356	H38966	369	H795LS	619
H115903R	147	H34251	356	H38SHFDV	375, 546	H80170	749
H115904L	147	H34480	356	H4022	114, 161, 288, 321, 334, 369, 830	H80180	749
H115905R	147	H34834R	356	H4028	114, 161, 288, 321, 369, 830	H80191	284, 749
H115906L	147	H34835L	356	H4029	114, 161, 288, 321, 369, 830	H80192	284, 749
H115907R	147	H34962	356	H432	670	H80193	284, 749
H115908L	147	H34973R	356	H434	670	H872	616
H115909	147	H34974L	356	H482	670	H873	616
H11592	141	H36720(?)	615	H484	670	H874	616
H11593	148	H36723(?)	615	H511596	622	H875	616
H11594	141	H36820(?)	615	H512	675	H875LS	617
H11595	148	H36823(?)	615	H51204	831	H882	616
H11596	141	H38155	367	H51206	321, 369, 831	H88231	340

CROSS REFERENCE INDEX

MODEL	PAGE	MODEL	PAGE	MODEL	PAGE	MODEL	PAGE
H88235R	340	H94224	332	HAPGCP239TPN	665	HBLPBRIDGE	125
H88236L	340	H94225	332	HAPGCS239TPN	665	HBLPCLASSIC	125
H88251R	339	H94226	332	HAPMAP196NFN	664	HBLPCONTEMP	125
H88263R	339	H94229	332	HAPMAP236NFN	664	HBMP2B	678
H88265R	339	H94234	330	HAPMBP196NPT	664	HBMP2F	678
H88266L	339	H94234K	330	HAPMBP199TFN	664	HBSMAUSB	826
H883	616	H94235	331	HAPMBP19SNPT	664	HBTMS	742
H884	616	H94236	330	HAPMBP236NPT	664	HBTTCW	693
H885	616	H94237	330	HAPMBP239TFN	664	HBTTD30	693
H885LS	617	H94237K	330	HAPMBS239TFN	664	HBTTD42	693
H88962	339	H94243	329	HAPMBS23SNPT	664	HBTTRND30	692
H88976	339	H94244	329	HAPMCPI99TPN	664	HBTTRND36	692
H892	616	H94245R	329	HAPMCP239TPN	664	HBTTRND42	692
H893	616	H94246L	329	HAPMCS239TPN	664	HBTTSFT30	692
H894	616	H94247R	329	HARCHA1	786	HBTTSFT36	692
H895	616	H94248L	329	HARCHA2	161, 285, 318	HBTTSFT42	692
H895LS	617	H94251	328	HARCHA3	161, 285, 318	HBTTSQR30	692
H90031	313	H94260	329	HARCHA8	786	HBTTSQR36	692
H90032	313	H94270	329	HARCHC1	786	HBTTSQR42	692
H90033	313	H94271	328	HARCHC2	161, 285, 318	HBTTX30L	693
H90034	313, 331	H94276	328	HARCHC3	161, 285, 318	HBTTX30S	693
H90035	313, 331	H94283R	328	HARCHC8	786	HBTTX42L	693
H90050	59, 65, 272	H94284L	328	HAS18	623	HBTTX42S	693
H90051	59, 65, 155, 272	H94285R	328	HAS24	623	HBV-P4224	607
H90052	59, 65, 155, 272	H94286L	328	HAUFHL15N	667	HBV-P4230	607
H90053	59, 65, 155, 272	H94291	332	HAUFHRI5N	667	HBV-P4236	607
H90054	59, 65, 155, 272	H94430	332	HAUFOI5N	667	HBV-P4242	607
H90055	59, 65, 155, 272	H94435	332	HB9	622	HBV-P4248	607
H90056	59, 65, 155, 272	H94720	333	HBAFM2036	116, 130, 135, 169, 230, 290, 324, 336, 344, 353, 360, 373, 532, 603, 724, 839	HBV-P4260	607
H90057	59, 65, 155, 272	H94721R	333			HBV-P4272	607
H9170(?)	654	H94722L	333			HBV-P6024	607
H9173(?)	654	HACRYEXSCRN2036	852C	HBCKIT24	579	HBV-P6030	607
H9174(?)	654	HACRYEXSCRN2042	852C	HBCKIT30	579	HBV-P6036	607
H9175(?)	654	HACRYEXSCRN2536	852C	HBCKIT36	579	HBV-P6042	607
H9180(?)	654	HACRYEXSCRN2542	852C	HBCKIT24	579	HBV-P6048	607
H9183(?)	654	HACRYSCRN2024	852C	HBCKIT30	579	HBV-P6060	607
H9184(?)	654	HACRYSCRN2030	852C	HBCKIT36	579	HBV-P6072	607
H9185(?)	654	HACRYSCRN2036	852C	HBCKIT42	579	HBV-P7224	607
H9185LS(?)	655	HACRYSCRN2048	852C	HBCKIT48	579	HBV-P7230	607
H9185LSN(?)	655	HACRYSCRN2054	852C	HBCKIT60	579	HBV-P7236	607
H9190(?)	654	HACRYSCRN2060	852C	HBCKIT66	579	HBV-P7242	607
H9193(?)	654	HACRYSCRN2066	852C	HBCKIT72	579	HBV-P7248	607
H9194(?)	654	HACRYSCRN2524	852C	HBCSR1524P	578	HBV-P7260	607
H919430	633, 634, 676	HACRYSCRN2530	852C	HBCSR1530P	578	HBV-PBS	608
H919436	633, 634, 676	HACRYSCRN2536	852C	HBCSR1536P	578	HBV-PWB1	608
H919442	676	HACRYSCRN2548	852C	HBCSR1542P	578	HBV-QC180	608
H919448	633, 634	HACRYSCRN2554	852C	HBCSR1548P	578	HBV-QC90	608
H919460	633, 634, 676	HACRYSCRN2560	852C	HBCSR1560P	578	HBV-TBASE	608
H919466	676	HACRYSCRN2566	852C	HBCSR1566P	578	HBV-VSH24	608
H919472	633, 634, 676	HAECBH	668	HBCSR1572P	578	HBV-VSH30	608
H919491	676	HAEHF	668	HBCSR2424P	578	HBV-VSH36	608
H919492	676	HAELT	668	HBCSR3030P	578	HBV-VSH42	608
H9195(?)	654	HAESC19	666	HBCSR3636P	578	HBV-VSH48	608
H94011	779	HAESS	668	HBDMAUSB	115, 129, 134, 168, 224, 289, 323, 335, 343, 352, 359, 372, 602, 723, 825, 838	HBV-VSH60	608
H94210	332	HAEST	668			HBWCT3624P	491, 573
H94211R	328	HAPGBP196NPT	665			HBWCT4224P	491, 573, 721
H94212L	328	HAPGBP199TFN	665	HBEAFM1	116, 130, 135, 169, 230, 290, 324, 336, 344, 353, 360, 373, 532, 603, 724, 839	HBWCT4230P	491, 573, 721
H94215R	328	HAPGBP19SNPT	665			HBWCT4824P	491, 573, 721
H94216L	328	HAPGBP236NPT	665			HBWCT4830P	491, 573, 721
H94220	332	HAPGBP239TFN	665	HBL72BFMODG	120	HBWD2450P	577
H94221	332	HAPGBS239TFN	665	HBL72HDG	121	HBWD3062P	577
H94222	332	HAPGBS23SNPT	665	HBLH3160	750	HBWQ2424P	577
H94223	332	HAPGCP199TPN	665	HBLH3170	750	HBWQ3030P	577

CROSS REFERENCE INDEX

MODEL	PAGE	MODEL	PAGE	MODEL	PAGE	MODEL	PAGE
HBWQT2424P	577	HCTROUGH17	109, 165, 232, 545,	HEC65P2	457	HEOHRTA1560FD	537
HBWQT3030P	577		564, 742, 746, 758,	HEC65P3	457	HEOHRTA1572FD	537
HBXRISER	115, 129, 134, 168, 229, 289, 323, 335, 343, 352, 359, 372, 602, 723, 838	HCTROUGH1710	109, 165, 232, 545, 564, 742, 746, 758,	HEC65PL	457	HEP35	560
HC14	348, 356		761, 787, 852	HEC65PS	457	HEP65	560
HCD1	161, 227, 288, 320, 334, 369, 600, 833	HCTROUGH36	109, 165, 232, 545, 564, 742, 746, 761, 787, 852	HEC65PT	457	HEPDMK42P	452
HCLA65	107, 163, 226, 288, 320, 596, 810, 846	HCTROUGH3610	109, 165, 232, 545, 564, 742, 746, 761, 787, 852	HEC65PX	457	HERD-42E-4L	709
HCM3648LN	840			HEC72P2	457	HERD-48E-4L	709
HCM3648LS	840	HCTSDS	689	HEC72P3	457	HEREPCVCR	505, 560
HCM4660LN	840	HCTSFT24	687	HEC72PL	457	HES1520F	454
HCM4660LS	840	HCTSFT30	687	HEC72PS	457	HES1520G	455
HCNLEG29	589	HCTSFT36	687	HEC72PT	457	HES1524F	454
HCOMDOME2	109, 166, 233, 341, 349, 357, 370, 506, 562, 598, 710, 716, 849	HCTSFT42	687	HEC72PX	457	HES1524G	455
HCPU	107, 288, 334, 341, 351, 357, 370, 827	HCTSFT48	687	HEC80P2	457	HES1530F	454
HCPU1	163, 224, 531, 600, 817, 827	HCTSQR24	687	HEC80P3	457	HES1530G	455
HCRESCENTA2	285, 318	HCTSQR30	687	HEC80PL	457	HES1536F	454
HCRESCENTA3	285, 318	HCTSQR36	687	HEC80PS	457	HES1536G	455
HCRESCENTC2	285, 318	HCTSQR42	687	HEC80PT	457	HES1542F	454
HCRESCENTC3	285, 318	HCWD2450P	577	HEC80PX	457	HES1542G	455
HCS3636P	580	HCWD3062P	577	HECB01	579	HES1548F	454
HCS4242P	580	HCWQ2424P	577	HECB42	579	HES1548G	455
HCT29LX	688	HCWQ3030P	577	HECC10	546	HES1560F	454
HCT29MT	688	HD2	369, 833	HECC15	546	HES1560G	455
HCT29MX	688	HD8	369, 833	HECPP	560	HES1572F	454
HCT29ST	688	HD8X	817	HECPP156	560	HES1572G	455
HCT29SX	688	HDPS1	110, 162, 226, 283, 319, 845	HECVH07P	458	HES3020G	455
HCT36LX	688	HE4022	114, 161, 288, 321, 334, 830	HECVH15P	458	HES3024G	455
HCT36MT	688	HEABAC	459	HECVH22P	458	HES3030G	455
HCT36MX	688	HEB4LEG	708	HECVH30P	458	HES3036G	455
HCT36ST	688	HEBPLATE336	453, 557	HEDRT-2766E-4L	707	HES3042G	455
HCT36SX	688	HEBPLATE342	453, 557	HEDRT-2766E-NS	707	HES3048G	455
HCT42LX	688	HEBPLATE348	453, 557	HEFEC35P	458	HES3060G	455
HCT42MT	688	HEBPLATE360	453, 557	HEFEC42P	458	HESA-2440E-4L	706
HCT42MX	688	HEBPLATE372	453, 557	HEFEC50P	458	HESA-3050E-4L	706
HCT42ST	688	HEC35P2	457	HEFEC57P	458	HESDMK30	452
HCT42SX	688	HEC35P3	457	HEFEC65P	458	HESDMK36	452
HCTL181L	589	HEC35PL	457	HEFEC72P	458	HESDMK42	452
HCTL181R	589	HEC35PS	457	HEFEC80P	458	HESDMK48	452
HCTL182	589	HEC35PT	457	HEFG0720	456	HESH-3060E-4L	709
HCTL241L	589	HEC35PX	457	HEFG0724	456	HESHRTA24	537
HCTL241R	589	HEC42P2	457	HEFG0730	456	HESHRTA30	537
HCTL242	589	HEC42P3	457	HEFG0736	456	HESHRTA36	537
HCTLDS	689	HEC42PL	457	HEFG0742	456	HESHRTA42	537
HCTMDS	689	HEC42PS	457	HEFG0748	456	HESHRTA48	537
HCTRECT2448	687	HEC42PT	457	HEFG0754	456	HESHRTA60	537
HCTRECT2460	687	HEC42PX	457	HEFG0760	456	HESHRTA72	537
HCTRECT2472	687	HEC50P2	457	HEFG0766	456	HESKD-7248E-4L	709
HCTRECT3048	687	HEC50P3	457	HEFG0772	456	HESN-3054E-4L	706
HCTRECT3060	687	HEC50PL	457	HEFG1520	456	HESNP-54E-4L	708
HCTRECT3072	687	HEC50PS	457	HEFG1524	456	HESNP54E	708
HCTRND24	687	HEC50PT	457	HEFG1530	456	HESQ-36E-4L	709
HCTRND30	687	HEC50PX	457	HEFG1536	456	HESQ-42E-4L	709
HCTRND36	687	HEC57P2	457	HEFG1542	456	HESQ-48E-4L	709
HCTRND42	687	HEC57P3	457	HEFG1548	456	HESW-3054E-4L	706
HCTRND48	687	HEC57PL	457	HEFG1554	456	HETB2018	544
		HEC57PS	457	HEFG1560	456	HETB2418	544
		HEC57PT	457	HEFG1566	456	HETB3018	544
		HEC57PX	457	HEFG1572	456	HETB3618	544
				HEFTAC	459	HETB4218	544
				HEOHRTA1524FD	537	HETB4818	544
				HEOHRTA1530FD	537	HETB6018	544
				HEOHRTA1536FD	537	HETB7218	544
				HEOHRTA1542FD	537	HETC20	453
				HEOHRTA1548FD	537	HETC24	453

CROSS REFERENCE INDEX

MODEL	PAGE	MODEL	PAGE	MODEL	PAGE	MODEL	PAGE
HETC30	453	HETR-3048E-4L	709	HFTLC3396	728	HH871136	558
HETC36	453	HETR-3060E-4L	709	HFTLD26	730	HH871136A	558
HETC42	453	HETR-3072E-4L	709	HFTLD30	728	HH871142	558
HETC48	453	HETZ-3060E-4L	709	HFTLD36	728	HH871142A	558
HETC60	453	HEVHF07P	458	HFTLR12	731	HH871148	504, 558
HETC66	453	HEVHF15P	458	HFTLS24	730	HH871148A	504, 558
HETC72	453	HEVHF22P	458	HFTLS30	728	HH871160	504, 558
HETC78	453	HEVHF30P	458	HFTLS36	728	HH871160A	504, 558
HETC84	453	HEWS35P	458	HFTLW45	731	HH871172	504, 558
HETC90	453	HEWS42P	458	HFTPTL18	730	HH871172A	504, 558
HETC96	453	HEWS50P	458	HFTTAL14	731	HH871224	558
HETD-54E-4L	707	HEWS57P	458	HFXB17B	729	HH871224A	558
HETP3520FP	450	HEWS65P	458	HFXB29A	729	HH871230	558
HETP3524FP	450	HEWS72P	458	HFXB29AN	729	HH871230A	558
HETP3530FP	450	HEWS80P	458	HFXB29B	729	HH871236	558
HETP3536FP	450	HF22	679, 853	HFXB42A	729	HH871236A	558
HETP3542FP	450	HF23B	112, 161, 286, 320, 334, 853	HFXB42AN	729	HH871242	558
HETP3548FP	450	HF23C	679, 853	HFXB42B	729	HH871242A	558
HETP3560FP	450	HF23S	112, 286, 634, 853	HGDK3-F	810, 812	HH871248	504, 558
HETP3572FP	450	HF24	677, 853	HGRMTAC	108, 165, 231, 287, 322, 564, 580, 689, 732, 746, 761, 817, 848	HH871248A	504, 558
HETP4220FP	450	HF246	677, 853			HH871260	504, 558
HETP4224FP	450	HF27B	112, 286, 320, 853			HH871260A	504, 558
HETP4230FP	450	HF27S	112, 286, 853	HGRMTAC2	108, 165, 231, 287, 322, 582, 689, 716, 732, 746, 761, 817, 835, 848	HH871272	504, 558
HETP4236FP	450	HF50	677			HH871272A	504, 558
HETP4242FP	450	HF60	677			HH871366	559
HETP4248FP	450	HF80	679	HGRMTDATA	231, 732, 746, 761, 848	HH871366A	559
HETP4260FP	450	HFDB17B	729	HGRMTUSB2	108, 165, 231, 287, 322, 564, 716, 732, 746, 817, 848	HH871400	505, 559
HETP4272FP	450	HFDB17N	729			HH871400A	505, 559
HETP5020DP	451	HFDB29A	729			HH871500	505, 559
HETP5020FP	450	HFDB29AN	729	HH15042SD	415, 452	HH871501	505, 561
HETP5024DP	451	HFDB29B	729	HH16542SD	415, 452	HH871501A	505, 561
HETP5024FP	450	HFDB42A	729	HH18042SD	415, 452	HH871502	505, 561
HETP5030DP	451	HFDB42AF	729	HH870070	232, 560	HH871502A	505, 561
HETP5030FP	450	HFDB42AF72	729	HH870924	842	HH871503	505, 561
HETP5036DP	451	HFDB42AF84	729	HH870924(?)	545	HH871503A	505, 561
HETP5036FP	450	HFDB42AF96	729	HH870924CH	842	HH871504	505, 561
HETP5042DP	451	HFDB42AFN	729	HH870930	113, 164, 274, 842	HH871506	505, 561
HETP5042FP	450	HFDB42AN	729	HH870930(?)	545	HH871601	505, 561
HETP5048DP	451	HFDB42B	729	HH870930CH	113, 842	HH871601A	561
HETP5048FP	450	HFDB42BF	729	HH870942	113, 164, 274, 321, 376, 842	HH871912	504, 559
HETP5060DP	451	HFLDGRMT	108, 164, 287, 322, 848	HH870942(?)	545	HH871912A	559
HETP5060FP	450	HFLDGRMT3	108, 164, 232, 287, 322, 848	HH870942CH	113, 842	HH871918	559
HETP5072DP	451	HFLDGRMT4	108, 848	HH870960	113, 164, 274, 321, 331, 376, 842	HH871918A	559
HETP6520DP	451	HFMBIN12	656	HH870960(?)	545	HH873500	559
HETP6520FP	450	HFMBIN3	656	HH870960CH	113, 331, 842	HH873501	561
HETP6524DP	451	HFMBIN6	656	HH871024	504, 558	HH873501A	561
HETP6524FP	450	HFMSC182830RWB	656	HH871024A	504, 558	HH873502	561
HETP6530DP	451	HFMSC183930RWB	656	HH871030	558	HH873502A	561
HETP6530FP	450	HFMSC185230RWB	656	HH871030A	558	HH873503	561
HETP6536DP	451	HFMSC186430RWB	656	HH871036	558	HH873503A	561
HETP6536FP	450	HFSC183640(?)	658	HH871036A	558	HH873504	561
HETP6542DP	451	HFSC183640W	657	HH871042	558	HH873506	561
HETP6542FP	450	HFSC183664(?)	658	HH871042A	558	HH879072	559
HETP6548DP	451	HFSC183664W	657	HH871048	504, 558	HH879072A	559
HETP6548FP	450	HFTB17N	729	HH871048A	504, 558	HH879168	559
HETP6560DP	451	HFTLA2460	728	HH871060	504, 558	HH879168A	559
HETP6560FP	450	HFTLA3372	728	HH871060A	504, 558	HH8988EBN	564
HETP6572DP	451	HFTLA3384	728	HH871072	504, 558	HHAB2S2L	128, 196, 581, 714, 834
HETP6572FP	450	HFTLA3396	728	HH871124	558	HHAB3S2L	97, 128, 196, 255, 581, 714, 834
HETR-2448E-4L	709	HFTLC2460	728	HH871124A	558	HHAB3S2L-G	715
HETR-2460E-4L	709	HFTLC3372	728	HH871130	558	HHAB3S3L	97, 128, 196, 255, 581, 714, 834
HETR-2472E-4L	709	HFTLC3384	728	HH871130A	558		

CROSS REFERENCE INDEX

MODEL	PAGE	MODEL	PAGE	MODEL	PAGE	MODEL	PAGE
HHAB3S3L-G	715	HHTADJ6	564	HLM7242	120	HLSL1336B3	222
HHABCASTER	710	HICG12	414, 452	HLM7242BF	120	HLSL1336B4	222
HHAW2448P	583, 718, 836	HKBS	227, 601, 828, 829	HLM72CRD	121	HLSL1436BH	215
HHAW2448PN	493	HKP2800	680	HLM72HUT	121	HLSL1436D	204, 541
HHAW2454P	583, 718, 836	HKTLONG	828	HLM72PEN	120	HLSL1436S	204, 540
HHAW2460P	583, 718, 836	HKT MID	828	HLMBBF	123	HLSL1442D	204, 541
HHAW2460PN	493	HKTSHORT	828	HLMBF	123	HLSL1442S	204, 540
HHAW2466P	583, 718, 836	HLAM3348RR	68, 281	HLMC48D	126, 733	HLSL1448D	204, 541
HHAW2472P	583, 718, 836	HLAM3772RD	68, 281	HLMC72R	126, 733	HLSL1448S	204, 540
HHAW2472PN	493	HLAMMP6030	87, 257	HLMFF	123	HLSL1460D	204, 541
HHAW3048P	583, 718, 836	HLAMMP7230	87, 257	HMLLATF	124	HLSL1460LS	223, 844
HHAW3048PN	493	HLAMSHB30	97, 255	HMPWC	122	HLSL1460M	205, 542
HHAW3054P	583, 718, 836	HLD-M3A	808	HLMRECP	122	HLSL1460S	204, 540
HHAW3060P	583, 718, 836	HLD-M3AA	808	HLMRECPRET	122	HLSL1466D	204, 541
HHAW3060PN	493	HLD-M3AB	808	HLMW4824	127	HLSL1466M	205, 542
HHAW3066P	583, 718, 836	HLD-M3F	808	HLMW4830	127	HLSL1466S	204, 540
HHAW3072P	583, 718, 836	HLD-M3FA	808	HLMW6024	127	HLSL1472D	204, 541
HHAW3072PN	493	HLD-M3FB	808	HLMW6030	127	HLSL1472DB	208
HHAWD2450PN	493	HLD-M3T	808	HLMW6624	127	HLSL1472LS	223, 844
HHAWD3062PN	493	HLDA-15	810	HLMW6630	127	HLSL1472M	205, 542
HHAWV603624LP	584, 719, 837	HL DST1	110, 162, 226, 282, 319, 844	HLMW7224	127	HLSL1472MB	205
HHAWV603624RP	584, 719, 837	HL DV-M3A	809	HLMW7230	127	HLSL1472S	204, 540
HHAWV604824LP	584, 719, 837	HL DV-M3F	809	HLSA-CR12	820	HLSL1472SB	208
HHAWV604824RP	584, 719, 837	HL DV-MRECT2026A	809	HLSA-HRK	820	HLSL14OSPL	206, 543
HHAWV604830LP	584, 719, 837	HLED1	113, 164, 228, 288, 321, 376, 597, 841	HLSA-SK1220T	820	HLSL1512LSCL	216
HHAWV604830RP	584, 719, 837	HLED17A	113, 164, 223, 274, 321, 376, 545, 842	HLSA-SK3020T	820	HLSL1512LSR	216
HHAWV723624LP	584, 719, 837	HLED17AS	113, 164, 223, 274, 321, 331, 376, 545, 842	HLSA-TK12	820	HLSL1512LSO	216
HHAWV723624RP	584, 719, 837	HLED17AS	113, 164, 223, 274, 321, 331, 376, 545, 842	HLSA-TK3	820	HLSL1530SOMB	106, 206, 543
HHAWV724824LP	584, 719, 837	HLED17AS	113, 164, 223, 274, 321, 331, 376, 545, 842	HLSA-TK6	820	HLSL1536SOMB	106, 206, 543
HHAWV724824RP	584, 719, 837	HLED17AS	113, 164, 223, 274, 321, 331, 376, 545, 842	HLSA-WBK52	820	HLSL154LSD	216
HHAWV724830LP	584, 719, 837	HLED17AUO	113, 164, 223, 274, 321, 376, 545, 842	HLSC36T-ID	819	HLSL154LSO	216
HHAWV724830RP	584, 719, 837	HLED17AUO	113, 164, 223, 274, 321, 376, 545, 842	HLSC36T-IN	818	HLSL1760SOL	206, 543
HHC-ARMPULL15	852B	HLED10C	113, 164, 228, 288, 321, 376, 597, 841	HLSC36T-2D	819	HLSL1760SOR	206, 543
HHC-ARMPULL5	852B	HLED2	113, 164, 228, 288, 321, 376, 597, 841	HLSC36T-2N	818	HLSL1772SOL	206, 543
HHC-FOOTPULL15	852B	HLED2	113, 164, 228, 288, 321, 376, 597, 841	HLSC52T-21D	819	HLSL1772SOR	206, 543
HHC-FOOTPULL5	852B	HLED2	113, 164, 228, 288, 321, 376, 597, 841	HLSC52T-21N	818	HLSL2016FP2	221
HHCMT24	564, 852	HLED31A	113, 164, 223, 274, 321, 376, 545, 842	HLSC52T-3D	819	HLSL2016MP2	214, 510
HHCMT36	564, 852	HLED31A	113, 164, 223, 274, 321, 376, 545, 842	HLSC52T-3N	818	HLSL2016PH2	71, 214, 510
HHC-PPESTND	852A	HLED31AS	113, 164, 223, 274, 321, 331, 376, 545, 842	HLSF52T-21D	819	HLSL2020TS	202
HHC-PPEWALL	852A	HLED31AS	113, 164, 223, 274, 321, 331, 376, 545, 842	HLSF52T-21N	818	HLSL2024TS	202
HHC-SANSTND	852A	HLED31AUO	113, 164, 223, 274, 321, 376, 545, 842	HLSF52T-3D	819	HLSL2028B	197, 594
HHC-SANSTND2	852A	HLED31AUO	113, 164, 223, 274, 321, 376, 545, 842	HLSF52T-3N	818	HLSL2028E	192
HHC-SANSTND-TRAY	852A	HLEDOSA	113, 164, 223, 274, 321, 376, 545, 842	HLSL1212	110, 162, 207, 223, 283, 319, 341, 351, 357, 370, 542, 846	HLSL2028F	197, 594
HHC-TASCRN3630	852D	HLINEARA1	786	HLSL1220FS	203	HLSL2028O	191, 587
HHC-TASCRN3636	852D	HLINEARA2	161, 285, 318	HLSL1220GS	203	HLSL2028SL	191
HHC-TASCRN3648	852D	HLINEARA3	161, 285, 318	HLSL1220TS	202	HLSL2030CH2	50, 71, 210, 214, 508, 509, 510
HHEM620	564	HLINEARA8	786	HLSL1224FS	98, 203	HLSL2030LDO	213, 509
HHKDMK30	415	HLINEARC1	786	HLSL1224GS	98, 203	HLSL2030LDOF	211
HHKDMK36	415	HLINEARC2	161, 285, 318	HLSL1224TS	202	HLSL2030LD1	213, 509
HHKDMK42	415	HLINEARC3	161, 285, 318	HLSL1230	98, 201, 257, 308	HLSL2030LD1F	211
HHKDMK48	415	HLINEARC8	786	HLSL1230FS	98, 203	HLSL2030LD2	213, 509
HHMRK36	544, 596	HLM42CU	121	HLSL1230GS	98, 203	HLSL2030LD2F	211
HHMRK42	544, 596	HLM42RET	121	HLSL1230TS	202	HLSL2030MCO	214, 510
HHMRK48	544, 596	HLM48BRG	121	HLSL1236	98, 201, 257, 308	HLSL2030TS	202
HHN831118	589	HLM48RET	121	HLSL1236FS	98, 203	HLSL2036CH2	50, 210, 508, 509
HHN831124	387, 582, 589, 835	HLM6030	120	HLSL1236GS	98, 203	HLSL2036L2	215
HHN831130	387, 582, 589, 835	HLM60CRD	121	HLSL1236TS	202	HLSL2036L4	215
HHPMC6	433, 452	HLM60HUT	121	HLSL1242	98, 201, 257, 308	HLSL2036LDO	213, 509
HHPSP1	110, 162, 226, 283, 319, 845	HLM65BC	124	HLSL1248	98, 201, 257, 308	HLSL2036LDOF	211
HHT2DP	561	HLM6630	120	HLSL1254	98, 201, 257, 308	HLSL2036LD1	213, 509
HHTADF3	564	HLM7236	120	HLSL1260	98, 201, 257, 308	HLSL2036LD1F	211
HHTADF4	564	HLM7236BF	120	HLSL1336B2	222	HLSL2036LD2	213, 509

CROSS REFERENCE INDEX

MODEL	PAGE	MODEL	PAGE	MODEL	PAGE	MODEL	PAGE
HLSL2036LD2F	211	HLSL3028B	197, 594	HLSLR2060	187	HLSLW486L	219, 512
HLSL2036SC	215	HLSL3028E	192	HLSLR2066	187	HLSLW486R	219, 512
HLSL2036TS	202	HLSL3028EBL	588	HLSLR2072	187	HLSLZ55C54	190, 249
HLSL2060LDO	209, 508	HLSL3028EBR	588	HLSLR2436	187	HLSLZ55C60	84, 190, 249
HLSL2060LDOF	211	HLSL3028F	197, 594	HLSLR2442	187	HLSLZ55C66	84, 190, 249
HLSL2060LD2	209, 508	HLSL3028O	94, 191, 252, 587	HLSLR2448	187, 195, 583, 718, 836	HLSLZ55C72	84, 190, 249
HLSL2060LD2F	211	HLSL3028S	197, 594	HLSLR2448J	189	HLSLZ55C78	84
HLSL2060LD4	209, 508	HLSL3028SL	94, 191, 253	HLSLR2454	187, 195, 583, 718, 836	HLSLZ55C84	84, 190, 249
HLSL2060LD4F	211	HLSL3041O	94, 193, 252, 592	HLSLR2460	187, 195, 583, 718, 836	HLT2460T-L3	815
HLSL2060LL2	209, 508	HLSL3041S	194	HLSLR2460J	189	HLT2460T-R3	815
HLSL2060LL2F	212	HLSL3041SL	94, 193, 252, 592	HLSLR2466	187, 195, 583, 718, 836	HLT2672T-23	815
HLSL2060LR2	209, 508	HLSL307O	94, 191, 210, 253	HLSLR2472	187, 195, 583, 718, 836	HLTA-TR24	815
HLSL2060LR2F	212	HLSL307SL	191	HLSLR2472J	189	HLTV2460T-3	816
HLSL2060S4	209, 508	HLSL30OBC	198, 595	HLSLR2484	187	HLTV2466T-33	816
HLSL2060S4F	212	HLSL3414LM	88, 199	HLSLR3036	188	HLVPM1	110, 162, 226, 282, 319, 333, 844
HLSL2072LDO	209, 508	HLSL3428LM	88, 199	HLSLR3042	188	HLVPM2	110, 162, 282, 319, 845
HLSL2072LDOF	211	HLSL3614L	87, 199, 256, 586, 722	HLSLR3048	188, 195, 583, 718, 836	HLWBF1-1248W	821
HLSL2072LD2	209, 508	HLSL3614MM	87, 200, 257, 586, 722	HLSLR3048J	189	HLWBF2-1248W	821
HLSL2072LD2F	211	HLSL3635TS	202	HLSLR3054	188, 195, 583, 718, 836	HLWBS-248WT	821
HLSL2072LD4	209, 508	HLSL36TW	205, 207	HLSLR3060	188, 195, 583, 718, 836	HLWBS-248WW	821
HLSL2072LD4F	211	HLSL4014LM	88, 199	HLSLR3060J	189	HLWBS-448WT	821
HLSL2072LL2	209, 508	HLSL4028LM	88, 199	HLSLR3066	188, 195, 583, 718, 836	HLWBS-448WW	821
HLSL2072LL2F	212	HLSL4214L	87, 199, 256, 586, 722	HLSLR3072	188, 195, 583, 718, 836	HLWR-12	821
HLSL2072LR2	209, 508	HLSL4214MM	87, 200, 257, 586, 722	HLSLR3072J	189	HMACABLE	745, 760, 789
HLSL2072LR2F	212	HLSL4235TS	202	HLSLR3084	188	HMAGANG	710, 742, 758
HLSL2072S4	209, 508	HLSL42TW	205, 207	HLSLR3660	188	HMAJUMP	745, 760
HLSL2072S4F	212	HLSL4814L	87, 199, 256, 586, 722	HLSLR3666	188	HMAPLATE	745, 760, 789
HLSL207O	191, 210	HLSL4814MM	87, 200, 257, 586, 722	HLSLR3672	188	HMAPOWER36	760
HLSL207SL	191	HLSL4828O	94, 191, 252	HLSLSB	207	HMAPOWER362	760
HLSL220SPL	206, 543	HLSL4831MB	223, 786, 847	HLSLSPBL	193	HMAPOWER42	760
HLSL2428B	197, 594	HLSL4835TS	202	HLSLSPBR	193	HMAPOWER48	745, 760
HLSL2428E	192	HLSL48TW	205, 207	HLSLW045L	218, 511	HMAPOWER482	745, 760
HLSL2428EBL	588	HLSL4AM2	192	HLSLW045LF	220	HMAPOWER54	760
HLSL2428EBR	588	HLSL50OS	207, 542	HLSLW045R	218, 511	HMAPOWER542	760
HLSL2428F	197, 594	HLSL5414L	87, 199, 256, 586, 722	HLSLW045RF	220	HMAPOWER60	745, 760, 789
HLSL2428O	94, 191, 252, 587	HLSL5414MM	87, 200, 257, 586, 722	HLSLW046L	218, 511	HMAPOWER602	745, 760
HLSL2428S	197, 594	HLSL5435TS	202	HLSLW046R	218, 511	HMAPOWER66	760
HLSL2428SL	94, 191, 253	HLSL6014L	87, 199, 256, 586, 722	HLSLW084L	220	HMAPOWER662	760
HLSL2430L	198, 595	HLSL6014MM	87, 200, 257, 586, 722	HLSLW084LF	220	HMAPOWER72	745, 760, 789
HLSL2430MF	198, 595	HLSL6028O	94, 191, 252	HLSLW084R	220	HMAPOWER722	745, 760
HLSL2436L2	215	HLSL6035TS	202	HLSLW084RF	220	HMAPOWER84	745, 760, 789
HLSL2436L4	215	HLSL60TW	205, 207	HLSLW085L	219, 512	HMAPOWER842	745, 760
HLSL2436SC	215	HLSL65OS	207, 542	HLSLW085LF	220	HMAPOWER96	745, 760, 789
HLSL2441O	94, 193, 252, 592	HLSL6635TS	202	HLSLW085R	219, 512	HMAPOWER962	745, 760
HLSL2441S	194	HLSL66TW	205, 207	HLSLW085RF	220	HMASD	114, 163, 224, 286, 531, 600, 825
HLSL2441SL	94, 193, 252, 592	HLSL7235TS	202	HLSLW086L	219, 512	HMASTS	114, 163, 224, 286, 531, 600, 826
HLSL2472LC	215	HLSL7265TE	208	HLSLW086R	219, 512	HMBFLIP18L	741
HLSL247O	94, 191, 210, 253	HLSL72TW	205, 207	HLSLW1224L	194	HMBFLIP18S	741
HLSL247SL	191	HLSL78TW	205, 207	HLSLW1224R	194	HMBFLIP24L	741
HLSL24OBC	198, 595	HLSLDRWORG	223, 846	HLSLW1230L	194	HMBFLIP24S	741
HLSL2814LM	88, 199	HLSLPBL	192, 587	HLSLW1230R	194	HMBFLIP30L	741
HLSL2828LM	88, 199	HLSLPBR	192, 587	HLSLW445L	218, 511	HMBFLIP30S	741
HLSL2830	98, 201	HLSLPMB	542	HLSLW445LF	220	HMBPOST	96, 741
HLSL2836	98, 201	HLSLPMBSO42	206, 543	HLSLW445R	218, 511	HMBPOST1	589
HLSL2842	98, 201	HLSLPMBSOA	206, 543	HLSLW445RF	220	HMBTLEG18	741
HLSL2848	98, 201	HLSLPMBSOB	206, 543	HLSLW446L	218, 511	HMBTLEG24	96, 741
HLSL2854	98, 201	HLSLR1330	207, 216	HLSLW446LP	218, 511	HML8851	750
HLSL2860	98, 201	HLSLR1336	207, 216	HLSLW446R	218, 511	HML8852	750
HLSL28AM2	192	HLSLR1345	207, 216	HLSLW446RP	218, 511	HML8858	712
HLSL28AW2	192	HLSLR2036	187	HLSLW485L	219, 512		
HLSL28P	47, 95, 192, 251, 589	HLSLR2042	187	HLSLW485LF	220		
HLSL3014L	87, 199, 256, 586, 722	HLSLR2048	187	HLSLW485R	219, 512		
HLSL3014MM	87, 200, 257, 586, 722	HLSLR2054	187	HLSLW485RF	220		

CROSS REFERENCE INDEX

MODEL	PAGE	MODEL	PAGE	MODEL	PAGE	MODEL	PAGE
HMNG15PED	133	HMPFG6013	496	HMPLM4826	497	HMTHR3248G	740
HMNG48WKS	132	HMPFG6020	496	HMPLM4834	497	HMTLEXSCRN2036	852C
HMNG60WKS	132	HMPFG7213	496	HMPLM6013	497	HMTLEXSCRN2042	852C
HMNG72WKS	132	HMPFG7220	496	HMPLM6026	497	HMTLEXSCRN2536	852C
HMNGDLEG	132	HMPFGS3613	496	HMPLM6034	497	HMTLEXSCRN2542	852C
HMP120EL4828	486	HMPFGS3620	496	HMPPP125	506	HMTLSCRN2024	852C
HMP120EL6028	486	HMPFGS4213	496	HMPRLEL2428	485, 489	HMTLSCRN2030	852C
HMP120POST	486	HMPFGS4220	496	HMPRREL2428	485, 489	HMTLSCRN2036	852C
HMP120TROUGH36	488	HMPFGS4813	496	HMPSL2428	485	HMTLSCRN2048	852C
HMP120TROUGH42	488	HMPFGS4820	496	HMPSL3028	485	HMTLSCRN2054	852C
HMP120TROUGH48	488	HMPFGS5413	496	HMPSL4828	485	HMTLSCRN2060	852C
HMP120UB236	487	HMPFGS5420	496	HMPSL6028	485	HMTLSCRN2066	852C
HMP120UB242	487	HMPFGS6013	496	HMPSTROUGH48	488	HMTLSCRN2524	852C
HMP120UB248	487	HMPFGS6020	496	HMPSTROUGH60	488	HMTLSCRN2530	852C
HMP144	504	HMPFGS7213	496	HMPSTROUGH72	488	HMTLSCRN2536	852C
HMP2460PK2	498	HMPFGS7220	496	HMPT2448NS	695	HMTLSCRN2548	852C
HMP2460PK4	498	HMPFSS3613	495	HMPT2460NS	695	HMTLSCRN2554	852C
HMP2460PK6	498	HMPFSS3620	495	HMPT2472NS	695	HMTLSCRN2560	852C
HMP2460PK8	498	HMPFSS4213	495	HMPT3048NS	695	HMTLSCRN2566	852C
HMP2472PK2	498	HMPFSS4220	495	HMPT3060NS	695	HMTUMOD26	756
HMP2472PK4	498	HMPFSS4813	495	HMPT3072NS	695	HMTUMOD32	742, 756, 816
HMP2472PK6	498	HMPFSS4820	495	HMPBFX	694	HMTUMOD38	695, 756
HMP2472PK8	498	HMPFSS5413	495	HMPBNSL	694	HMTUMOD44	742, 756
HMP3060PK2	498	HMPFSS5420	495	HMPBNSS	694	HMTUMOD50	695, 756
HMP3060PK4	498	HMPFSS6013	495	HMPTROUGH48	488	HMTUMOD56	756
HMP3060PK6	498	HMPFSS6020	495	HMPTROUGH60	488	HMTUMOD62	756
HMP3060PK8	498	HMPHA2460PK2	499	HMPTROUGH72	488	HMTUMOD74	756
HMP3072PK2	498	HMPHA2460PK4	499	HMPPT2448	694	HMTUMOD86	756
HMP3072PK4	498	HMPHA2460PK6	499	HMPPT2460	694	HMVH-2448(?)-FX	753
HMP3072PK6	498	HMPHA2460PK8	499	HMPPT2472	694	HMVH-2448(?)-NS	754
HMP3072PK8	498	HMPHA2472PK2	499	HMPPT3048	694	HMVH-3060(?)-FX	753
HMPCF52413	495	HMPHA2472PK4	499	HMPPT3060	694	HMVH-3060(?)-NS	754
HMPCF52420	495	HMPHA2472PK6	499	HMPPT3072	694	HMVH-3672(?)-FX	753
HMPCF53013	495	HMPHA2472PK8	499	HMPUB148	487, 489	HMVH-3672(?)-NS	754
HMPCF53020	495	HMPHA254C	492	HMPUB160	487, 489	HMVMB-3072WW	757
HMPCF53613	495	HMPHA3060PK2	499	HMPUB172	487	HMVMB-3672WW	757
HMPCF53620	495	HMPHA3060PK4	499	HMPUB248	487	HMVPC-DTLG	757
HMPCF54213	495	HMPHA3060PK6	499	HMPUB260	487	HMVPC-MP	757
HMPCF54220	495	HMPHA3060PK8	499	HMPUB272	487	HMVPCA1-1830G	757
HMPCF54813	495	HMPHA3072PK2	499	HMPVWM28	109, 166, 233, 341, 349, 357, 370, 506, 562, 598, 852	HMVPCA1-1830R	757
HMPCF54820	495	HMPHA3072PK4	499	HMT1848E	739	HMVPCA2-1830G	757
HMPCF56013	495	HMPHA3072PK6	499	HMT1848G	739	HMVPCA2-1830R	757
HMPCF56020	495	HMPHA3072PK8	499	HMT1860E	739	HMVPCF-1830G	757
HMPDFS2413	494	HMPHABEORKIT	492	HMT1860G	739	HMVPCF-1830R	757
HMPDFS2420	494	HMPHASLID20	492	HMT1872E	739	HMVPCSS-4C	757
HMPDFS3013	494	HMPHASLID48	492	HMT1872G	739	HMVPCSS-4C4C	757
HMPDFS3020	494	HMPHASLID60	492	HMT2448E	739	HMVPCSS-4C9C	757
HMPDMS2413	494	HMPHASLID72	492	HMT2448G	739	HMVPCSS-4O	757
HMPDMS3013	494	HMPHATFWML	506, 562, 582, 716, 835	HMT2460E	739	HMVPCSS-4O4C	757
HMPEL2428	485	HMPHATROUGH20	492	HMT2460G	739	HMVPCSS-4O9C	757
HMPEL3028	485	HMPHATROUGH48	492	HMT2472E	739	HMVR-1848(?)-AH	755
HMPEL4828	485	HMPHATROUGH60	492	HMT2472G	739	HMVR-1848(?)-FX	753
HMPEL6028	485	HMPHATROUGH72	492	HMPJUMP	504	HMVR-1848(?)-NS	754
HMPFG2413	496	HMPHAWTWML	506, 562, 835	HMPGP4850	497	HMVR-1860(?)-AH	755
HMPFG2420	496	HMPJUMP	504	HMPPLGP6050	497	HMVR-1860(?)-FX	753
HMPFG3013	496	HMPLGP4850	497	HMPLM2426	497	HMVR-1860(?)-NS	754
HMPFG3020	496	HMPLGP6050	497	HMPLM2434	497	HMVR-1872(?)-AH	755
HMPFG3613	496	HMPLM2426	497	HMPLM2434	497	HMVR-1872(?)-FX	753
HMPFG3620	496	HMPLM2434	497	HMPLM3026	497	HMVR-1872(?)-NS	754
HMPFG4213	496	HMPLM3026	497	HMPLM3034	497	HMVR-2436(?)-AH	755
HMPFG4220	496	HMPLM3034	497	HMT3048E	739	HMVR-2436(?)-FX	753
HMPFG4813	496	HMPLM3613	497	HMT3048G	739	HMVR-1860(?)-NS	754
HMPFG4820	496	HMPLM4813	497	HMT3060E	739	HMVR-1872(?)-AH	755
				HMT3060G	739	HMVR-1872(?)-FX	753
				HMT3072E	739	HMVR-1872(?)-NS	754
				HMT3072G	739	HMVR-2436(?)-AH	755
				HMTHR3060E	740	HMVR-2436(?)-FX	753
				HMTHR3060G	740	HMVR-2436(?)-NS	754
				HMTHR3248E	740	HMVR-2442(?)-AH	755

CROSS REFERENCE INDEX

MODEL	PAGE	MODEL	PAGE	MODEL	PAGE	MODEL	PAGE
HMVR-2442(?)-FX	753	HNL11SUPP	93	HNL233028PSL	102	HNL2948FD	64
HMVR-2442(?)-NS	754	HNL122428BKE	102	HNL233628PBK	102	HNL2948LD	64
HMVR-2448(?)-AH	755	HNL123028BKE	102	HNL233628PLF	101	HNL2948LL	64
HMVR-2448(?)-FX	753	HNL123628BKE	102	HNL233628PSC	102	HNL2948SD	65
HMVR-2448(?)-NS	754	HNL1530BK2	77	HNL233628PSL	102	HNL2960FD	64
HMVR-2454(?)-AH	755	HNL1530BK3	77	HNL241850TLL	76	HNL2960LD	64
HMVR-2454(?)-FX	753	HNL1530BK4	77	HNL241850TLR	76	HNL2960LL	64
HMVR-2454(?)-NS	754	HNL1530BK5	77	HNL241865SFLL	73	HNL2960SD	65
HMVR-2460(?)-AH	755	HNL1530BK6	77	HNL241865SFLL	73	HNL2966FD	64
HMVR-2460(?)-FX	753	HNL1530FD	63, 785	HNL241865SFX	73	HNL2966LD	64
HMVR-2460(?)-NS	754	HNL1530LD	62, 784	HNL241865WLL	75	HNL2966LL	64
HMVR-2466(?)-AH	755	HNL1530LL	62, 784	HNL241865WLR	75	HNL2966SD	65
HMVR-2466(?)-FX	753	HNL1536FD	63, 785	HNL241879WLL	75	HNL2972FD	64
HMVR-2466(?)-NS	754	HNL1536LD	62, 784	HNL241879WLR	75	HNL2972LD	64
HMVR-2472(?)-AH	755	HNL1536LL	62, 784	HNL242465TLL	76	HNL2972LL	64
HMVR-2472(?)-FX	753	HNL1542FD	63, 785	HNL242465TLR	76	HNL2972SD	65
HMVR-2472(?)-NS	754	HNL1542LD	62, 784	HNL242479TLL	76	HNL2978FD	64
HMVR-2484(?)-FX	753	HNL1542LL	62, 784	HNL242479TLR	76	HNL2978LD	64
HMVR-2484(?)-NS	754	HNL1548FD	63, 785	HNL2424BK5CL	77	HNL2978LL	64
HMVR-2496(?)-FX	753	HNL1548LD	62, 784	HNL2424BK5SCR	77	HNL2978SD	65
HMVR-2496(?)-NS	754	HNL1548LL	62, 784	HNL243629SC	73	HNL301850TLL	76
HMVR-3036(?)-AH	755	HNL1548SD	63, 785	HNL243665SC	73	HNL301850TLR	76
HMVR-3036(?)-FX	753	HNL1560FD	63, 785	HNL243665SLL	74	HNL3060DPRF	43
HMVR-3036(?)-NS	754	HNL1560LD	62, 784	HNL243665WL	75	HNL3066BUEP	46
HMVR-3042(?)-AH	755	HNL1560LL	62, 784	HNL243665WLBR	75	HNL3066DPRF	43
HMVR-3042(?)-FX	753	HNL1560SD	63, 785	HNL243665WRBL	75	HNL3066LPRF	45
HMVR-3042(?)-NS	754	HNL1566FD	63, 785	HNL243679SC	73	HNL3066RPRF	45
HMVR-3048(?)-AH	755	HNL1566LD	62, 784	HNL243679WL	75	HNL3072BUEP	46
HMVR-3048(?)-FX	753	HNL1566LL	62, 784	HNL243679WLBR	75	HNL3065SSEP	56
HMVR-3048(?)-NS	754	HNL1566SD	63, 785	HNL243679WRBL	75	HNL3630BHLD	66
HMVR-3054(?)-AH	755	HNL1572FD	63, 785	HNL2436LD2	72	HNL3630BHXD	66
HMVR-3054(?)-FX	753	HNL1572LD	62, 784	HNL2436LD3	72	HNL3630TB	106, 847
HMVR-3054(?)-NS	754	HNL1572LL	62, 784	HNL2436LD4	72	HNL3630WB	106, 847
HMVR-3060(?)-AH	755	HNL1572SD	63, 785	HNL2442BF	52	HNL3636BHFD	67
HMVR-3060(?)-FX	753	HNL1578FD	63, 785	HNL2442LP	51	HNL3636BHLD	66
HMVR-3060(?)-NS	754	HNL1578LD	62, 784	HNL2442RP	51	HNL3636BHXD	66
HMVR-3066(?)-AH	755	HNL1578LL	62, 784	HNL2448BF	52	HNL3636CU	48
HMVR-3066(?)-FX	753	HNL1578SD	63, 785	HNL2448LP	51	HNL3636FD	55
HMVR-3066(?)-NS	754	HNL1772RT	69	HNL2448RP	51	HNL3636LD	55
HMVR-3072(?)-AH	755	HNL203021D2	50	HNL2460DPK	49	HNL3636LL	55
HMVR-3072(?)-FX	753	HNL2030MSFC	71	HNL2466DPK	49	HNL3636TB	106, 847
HMVR-3072(?)-NS	754	HNL203621D2	50	HNL2472DPK	49	HNL3636WB	106, 847
HMVR-3084(?)-FX	753	HNL206021D4	50	HNL2472DPS	49	HNL3642FD	55
HMVR-3084(?)-NS	754	HNL206021LD2	50	HNL2472LLC	49	HNL3642LD	55
HMVR-3096(?)-FX	753	HNL206021RD2	50	HNL2472LP	49	HNL3642LL	55
HMVR-3096(?)-NS	754	HNL207221D4	50	HNL2472RLC	49	HNL3648FD	55
HMVR-3648(?)-AH	755	HNL207221LD2	50	HNL2472RP	49	HNL3648LD	55
HMVR-3648(?)-FX	753	HNL207221RD2	50	HNL291028PBFF	101	HNL3648LL	55
HMVR-3648(?)-NS	754	HNL2116MBBF	71	HNL291028PFF	101	HNL3648SD	56
HMVR-3660(?)-AH	755	HNL2116MBF	71	HNL291041PBFF	103	HNL3660FD	55
HMVR-3660(?)-FX	753	HNL2116MFF	71	HNL291628PBFF	101	HNL3660LD	55
HMVR-3660(?)-NS	754	HNL231028PBFF	101	HNL291628PFF	101	HNL3660LL	55
HMVR-3672(?)-AH	755	HNL231028PFF	101	HNL291641PBFF	103	HNL3660SD	56
HMVR-3672(?)-FX	753	HNL231041PBFF	103	HNL291641PSBFF	103	HNL3666FD	55
HMVR-3672(?)-NS	754	HNL231628PBFF	101	HNL2930FD	64	HNL3666LD	55
HMVT-2448(?)-FX	753	HNL231628PFF	101	HNL2930LD	64	HNL3666LL	55
HMVT-2448(?)-NS	754	HNL231641PBFF	103	HNL2930LL	64	HNL3666SD	56
HMVT-3060(?)-FX	753	HNL231641PSBFF	103	HNL2936FD	64	HNL3672BUEP	46
HMVT-3060(?)-NS	754	HNL231828PBFF	101	HNL2936LD	64	HNL3672DPBB	43
HMVT-3672(?)-FX	753	HNL231828PFF	101	HNL2936LL	64	HNL3672DPBFF	43
HMVT-3672(?)-NS	754	HNL233028PBK	102	HNL2942FD	64	HNL3672DPBR	43
HN899900	414, 452	HNL233028PLF	101	HNL2942LD	64	HNL3672DPRB	43
HN899910	414, 452	HNL233028PSC	102	HNL2942LL	64	HNL3672DPRBF	43

CROSS REFERENCE INDEX

MODEL	PAGE	MODEL	PAGE	MODEL	PAGE	MODEL	PAGE
HNL3672DPRR	43	HNL8472RLT	70	HNLMP7828	86	HP3276	347
HNL3672FD	55	HNL8472RT	69	HNLMP8410	86	HPACSM	826
HNL3672LD	55	HNLBU3048	82	HNLMP8428	86	HPACW	827
HNL3672LL	55	HNLBU3060	82	HNLMP9010	86	HPADD	825
HNL3672LPBB	44	HNLBU3066	82	HNLMP9028	86, 783	HPASD	826
HNL3672LPBBF	44	HNLBU3072	82	HNLMP9610	86	HPATF	825
HNL3672LPBR	44	HNLBU3078	82	HNLMP9628	86	HPC180G	47, 151, 266, 310
HNL3672LPBRB	45	HNLBU3084	82	HNLPB1028	105	HPC180W	47
HNL3672LPBRBF	45	HNLBW3672	82	HNLPB1041	105	HPC190X	46, 95, 251
HNL3672LPRR	45	HNLBW3684	82	HNLPB1628	105	HPC191X	46, 95, 251
HNL3672RPBB	44	HNLCDShelf	106	HNLPB1641	105	HPCW1	527, 646, 679
HNL3672RPBBF	44	HNLEC367224L	83	HNLPB1828	105	HPD2PNBRK2L	590
HNL3672RPBR	44	HNLEC367224R	83	HNLPT2416	104	HPD2PNBRK2R	590
HNL3672RPRB	45	HNLEC487224L	83	HNLPT2418	104	HPMARKER1	854
HNL3672RPRBF	45	HNLEC487224R	83	HNLPT3016	104	HPPMAS	430, 596
HNL3672RPRR	45	HNLEP1128	91	HNLRC2042V	81	HPPMFB	430, 596, 822
HNL3672SD	56	HNLEP1141	91	HNLRC2048V	81	HPPMHK	822
HNL3678FD	55	HNLEP2428L	90	HNLRC2430	80	HPPMPT	822
HNL3678LD	55	HNLEP2428R	90	HNLRC2430V	81	HPPMPB	430, 596, 822
HNL3678LL	55	HNLEP2441L	90	HNLRC2436	80, 783	HPPMPC	822
HNL3678SD	56	HNLEP2441R	90	HNLRC2436V	81	HPPMPS	430, 596
HNL4272JLEP	46	HNLEP247L	92, 250	HNLRC2442	80	HPPMST	430, 596
HNL4272JREP	46	HNLEP247R	92, 250	HNLRC2442V	81	HPPMST	430, 596
HNL4872JLEP	46	HNLEP3028L	90	HNLRC2448	80, 585, 720	HPSEAT18ND	679
HNL4872JREP	46	HNLEP3028R	90	HNLRC2448V	81	HPSEAT24ND	527, 529, 530, 646, 649, 653, 666, 679
HNL4905SSEP	59	HNLEP3041L	90	HNLRC2454	80, 783	HPWRMOD2	109, 166, 233, 255, 506, 582, 598, 696, 710, 716, 835, 849
HNL4930BHLD	66	HNLEP3041R	90	HNLRC2454V	81	HPWRMOD2UWM	109, 166, 233, 506, 562, 598, 710, 716, 732, 849
HNL4930BHxD	66	HNLEP307L	92, 250	HNLRC2460	80, 585, 720	HPWRMOD2WC	109, 166, 233, 341, 349, 357, 370, 506, 562, 598, 710, 716, 849
HNL4930TB	106, 847	HNLEP307R	92, 250	HNLRC2460V	81	HPWRMOD3UWM	109, 166, 233, 506, 562, 598, 710, 716, 732, 849
HNL4930WB	106, 847	HNLEP3628L	90	HNLRC2466	80, 585, 720	HPWRMOD3WC	109, 166, 233, 341, 349, 357, 370, 506, 562, 598, 710, 716, 849
HNL4936BHFD	67	HNLEP3628R	90	HNLRC2472	80, 585, 720, 783	HQB	743, 758
HNL4936BHLD	66	HNLLB1013	105	HNLRC2478	80	HQH1-3	743, 758
HNL4936BHxD	66	HNLLB1018	105	HNLRC2484	80	HQH5-3	743, 758
HNL4936FD	58	HNLLB1613	105	HNLRC2490	80, 783	HQH5-P	743, 758
HNL4936LD	57	HNLLB1618	105	HNLRC2496	80	HQJ3	743, 758
HNL4936LL	57	HNLLB1818	105	HNLRC3048	80, 585, 720	HRABAB	433
HNL4936TB	106, 847	HNLLB3018	105	HNLRC3060	80, 585, 720	HRFF3524P	411
HNL4936WB	106, 847	HNLLB3618	105	HNLRC3066	80, 585, 720	HRFF3530P	411
HNL4942FD	58	HNLEP2428L	92	HNLRC3072	80, 585, 720	HRFF3536P	411
HNL4942LD	57	HNLEP2428R	92	HNLRC3078	80	HRFF3542P	411
HNL4942LL	57	HNLEP2441L	92	HNLRC3084	80	HRFF3548P	411
HNL4948FD	58	HNLEP2441R	92	HNLRC3672	80	HRFF3560P	411
HNL4948LD	57	HNLEP3028L	92	HNLRC3684	80	HRFF4224P	411
HNL4948LL	57	HNLEP3028R	92	HNLTEP2428	93	HRFF4230P	411
HNL4948SD	59	HNLEP3041L	92	HNLTEP3028	93	HRFF4236P	411
HNL4960FD	58	HNLEP3041R	92	HNLTEP3628	93	HRFF4242P	411
HNL4960LD	57	HNLMP3010	86	HNPMBW24	429, 596	HRFF4248P	411
HNL4960LL	57	HNLMP3028	86	HNPMBW30	429, 596	HRFF4260P	411
HNL4960SD	59	HNLMP3610	86	HNPMBW36	429, 596	HRFF5024P	411
HNL4966FD	58	HNLMP3628	86, 783	HNPMBW42	429, 596	HRFF5030P	411
HNL4966LD	57	HNLMP4210	86	HNPMBW48	429, 596	HRFF5036P	411
HNL4966LL	57	HNLMP4228	86	HNPMBW60	429, 596	HRFF5042P	411
HNL4966SD	59	HNLMP4810	86	HOLEG12	587		
HNL4972FD	58	HNLMP4828	86	HOLEG24	587		
HNL4972LD	57	HNLMP5410	86	HOLEG30	587		
HNL4972LL	57	HNLMP5428	86, 783	HP3231	348		
HNL4972SD	59	HNLMP6010	86	HP3235R	347		
HNL4978FD	58	HNLMP6028	86	HP3236L	347		
HNL4978LD	57	HNLMP6610	86	HP3251R	347		
HNL4978LL	57	HNLMP6628	86	HP3261	347		
HNL4978SD	59	HNLMP7210	86	HP3262	347		
HNL7872RLT	70	HNLMP7228	86, 783	HP3265R	347		
HNL7872RT	69	HNLMP7810	86	HP3266L	347		

CROSS REFERENCE INDEX

MODEL	PAGE	MODEL	PAGE	MODEL	PAGE	MODEL	PAGE
HRFF5048P	411	HRVC50GP	437	HRVF4248P	410	HRVG4239L	434
HRFF5060P	411	HRVC50PF	418	HRVF4260P	410	HRVG4239LG	435
HRFF6524P	411	HRVC50PL	416	HRVF5024P	410	HRVG4242L	434
HRFF6530P	411	HRVC50PS	416	HRVF5030P	410	HRVG4242LG	435
HRFF6536P	411	HRVC50PT	416	HRVF5036P	410	HRVG4245L	434
HRFF6542P	411	HRVC50PX	416	HRVF5042P	410	HRVG4245LG	435
HRFF6548P	411	HRVC50PY2	417	HRVF5048P	410	HRVG4248L	434
HRFF6560P	411	HRVC50PY3	417	HRVF5060P	410	HRVG4248LG	435
HRFTAB	433	HRVC65GP	437	HRVF6524P	410	HRVG4251L	434, 434A
HRVBPLATE336	413, 557	HRVC65PF	418	HRVF6530P	410	HRVG4251LG	435, 435A
HRVBPLATE342	413, 557	HRVC65PL	416	HRVF6536P	410	HRVG4260L	434
HRVBPLATE348	413, 557	HRVC65PS	416	HRVF6542P	410	HRVG4260LG	435
HRVBPLATE360	413, 557	HRVC65PT	416	HRVF6548P	410	HRVG4263L	434, 434A
HRVBRI524	579	HRVC65PW	418	HRVF6560P	410	HRVG4263LG	435, 435A
HRVBRI524P	579	HRVC65PX	416	HRVFFOOT	411	HRVG4275L	434A
HRVBRI530	579	HRVC65PY2	417	HRVFSB24	412	HRVG4275LG	435A
HRVBRI530P	579	HRVC65PY3	417	HRVFSB30	412	HRVG5024L	434
HRVBRI536	579	HRVC7FFV	418	HRVFSB36	412	HRVG5024LG	435
HRVBRI536P	579	HRVC7PFT	418	HRVFSB42	412	HRVG5027L	434
HRVBRI542	579	HRVC7PFV	418	HRVFSB48	412	HRVG5027LG	435
HRVBRI548	579	HRVC7PL	416	HRVFSB60	412	HRVG5030L	434
HRVBRI560	579	HRVC7PS	416	HRVFSBW24	419	HRVG5030LG	435
HRVBRI566	579	HRVC7PT	416	HRVFSBW30	419	HRVG5033L	434
HRVBRI572	579	HRVC7PX	416	HRVFSBW36	419	HRVG5033LG	435
HRVC15FFV	418	HRVC80PF	418	HRVFSBW42	419	HRVG5036L	434
HRVC15PF	418	HRVC80PL	416	HRVFSBW48	419	HRVG5036LG	435
HRVC15PFT	418	HRVC80PS	416	HRVFSBW60	419	HRVG5039L	434
HRVC15PFV	418	HRVC80PT	416	HRVG3524L	434	HRVG5039LG	435
HRVC15PL	416	HRVC80PX	416	HRVG3524LG	435	HRVG5042L	434
HRVC15PS	416	HRVCE	437	HRVG3527L	434	HRVG5042LG	435
HRVC15PT	416	HRVCLG24	386, 587	HRVG3527LG	435	HRVG5045L	434
HRVC15PX	416	HRVCLG30	386, 587	HRVG3530L	434	HRVG5045LG	435
HRVC22PFT	418	HRVCM	437	HRVG3530LG	435	HRVG5048L	434
HRVC22PFV	418	HRVD0742T	414	HRVG3533L	434	HRVG5048LG	435
HRVC22PL	416	HRVD9542P	414	HRVG3533LG	435	HRVG5051L	434, 434A
HRVC22PS	416	HRVEP1129L	386, 587	HRVG3536L	434	HRVG5051LG	435, 435A
HRVC22PT	416	HRVEP1129R	386, 587	HRVG3536LG	435	HRVG5060L	434
HRVC22PX	416	HRVEP2429L	386, 587	HRVG3539L	434	HRVG5060LG	435
HRVC30PF	418	HRVEP2429R	386, 587	HRVG3539LG	435	HRVG5063L	434, 434A
HRVC30PFT	418	HRVEP3029L	386, 587	HRVG3542L	434	HRVG5063LG	435, 435A
HRVC30PFV	418	HRVEP3029R	386, 587	HRVG3542LG	435	HRVG5075L	434A
HRVC30PL	416	HRVF1524	412	HRVG3545L	434	HRVG5075LG	435A
HRVC30PS	416	HRVF1530	412	HRVG3545LG	435	HRVGLSK	437
HRVC30PT	416	HRVF1536	412	HRVG3548L	434	HRVGMSK	437
HRVC30PX	416	HRVF1542	412	HRVG3548LG	435	HRVOH1530RM	536
HRVC35GP	437	HRVF1548	412	HRVG3551L	434A	HRVOH1536RM	536
HRVC35PCE	418, 458, 591	HRVF1560	412	HRVG3551LG	435A	HRVOH1542RM	536
HRVC35PCM	418, 458, 591	HRVF3024	412	HRVG3560L	434	HRVOH1548RM	536
HRVC35PF	418	HRVF3030	412	HRVG3560LG	435	HRVOH1560RM	536
HRVC35PL	416	HRVF3036	412	HRVG3563L	434A	HRVOH24FM	536
HRVC35PS	416	HRVF3042	412	HRVG3563LG	435A	HRVOH30FM	536
HRVC35PT	416	HRVF3048	412	HRVG3575L	434A	HRVOH36FM	536
HRVC35PX	416	HRVF3060	412	HRVG3575LG	435A	HRVOH42FM	536
HRVC35PY2	417	HRVF3524P	410	HRVG4224L	434	HRVOH48FM	536
HRVC35PY3	417	HRVF3530P	410	HRVG4224LG	435	HRVOH60FM	536
HRVC42GP	437	HRVF3536P	410	HRVG4227L	434	HRVOH72FM	536
HRVC42PF	418	HRVF3542P	410	HRVG4227LG	435	HRVOHV24HLA	539
HRVC42PL	416	HRVF3548P	410	HRVG4230L	434	HRVOHV24HMA	538
HRVC42PS	416	HRVF3560P	410	HRVG4230LG	435	HRVOHV30HLA	539
HRVC42PT	416	HRVF4224P	410	HRVG4233L	434	HRVOHV30HMA	538
HRVC42PX	416	HRVF4230P	410	HRVG4233LG	435	HRVOHV36HLA	539
HRVC42PY2	417	HRVF4236P	410	HRVG4236L	434	HRVOHV36HMA	538
HRVC42PY3	417	HRVF4242P	410	HRVG4236LG	435	HRVOHV42HLA	539

CROSS REFERENCE INDEX

MODEL	PAGE	MODEL	PAGE	MODEL	PAGE	MODEL	PAGE
HRVOHV42HMA	538	HRVT1530PM	432	HRVT3024PM	432	HRVT3760E	422
HRVOHV48HLA	539	HRVT1530R	426	HRVT3024R	426	HRVT3760HS2	424
HRVOHV48HMA	538	HRVT1530T	420	HRVT3024T	420	HRVT3760T	420
HRVOMOD	419	HRVT1530W	429	HRVT3030CK	433	HRVT4524E	423
HRVP24P	560	HRVT1536CK	433	HRVT3030E	422	HRVT4524T	421
HRVP30P	560	HRVT1536E	422	HRVT3030G	425	HRVT4530E	423
HRVP36P	560	HRVT1536F	427	HRVT3030HS2	424	HRVT4530T	421
HRVP42P	560	HRVT1536G	425	HRVT3030M	431	HRVT4536E	423
HRVP48P	560	HRVT1536HS2	424	HRVT3030P	428	HRVT4536T	421
HRVP60P	560	HRVT1536M	431	HRVT3030PM	432	HRVT4542E	423
HRVSH24	536	HRVT1536PM	432	HRVT3030R	426	HRVT4542T	421
HRVSH30	536	HRVT1536R	426	HRVT3030T	420	HRVT4548E	423
HRVSH36	536	HRVT1536T	420	HRVT3036CK	433	HRVT4548T	421
HRVSH42	536	HRVT1536W	429	HRVT3036E	422	HRVT4560E	423
HRVSH48	536	HRVT1542CK	433	HRVT3036G	425	HRVT4560T	421
HRVSH60	536	HRVT1542E	422	HRVT3036HS2	424	HRVT6024E	423
HRVSH72	536	HRVT1542F	427	HRVT3036M	431	HRVT6024T	421
HRVSHV24	538	HRVT1542G	425	HRVT3036P	428	HRVT6030E	423
HRVSHV30	538	HRVT1542HS2	424	HRVT3036PM	432	HRVT6030T	421
HRVSHV36	538	HRVT1542M	431	HRVT3036R	426	HRVT6036E	423
HRVSHV42	538	HRVT1542PM	432	HRVT3036T	420	HRVT6036T	421
HRVSHV48	538	HRVT1542R	426	HRVT3042CK	433	HRVT6042E	423
HRVSS24	413	HRVT1542T	420	HRVT3042E	422	HRVT6042T	421
HRVSS30	413	HRVT1542W	429	HRVT3042G	425	HRVT6048E	423
HRVSS36	413	HRVT1548CK	433	HRVT3042HS2	424	HRVT6048T	421
HRVSS42	413	HRVT1548E	422	HRVT3042M	431	HRVT6060E	423
HRVSS48	413	HRVT1548F	427	HRVT3042P	428	HRVT6060T	421
HRVSS60	413	HRVT1548G	425	HRVT3042PM	432	HRVTB11	438
HRVT0724F	427	HRVT1548HS2	424	HRVT3042R	426	HRVTB18	438
HRVT0724T	420, 428	HRVT1548M	431	HRVT3042T	420	HRVTC24	410
HRVT0730F	427	HRVT1548PM	432	HRVT3048CK	433	HRVTC30	410
HRVT0730T	420, 428	HRVT1548R	426	HRVT3048E	422	HRVTC36	410
HRVT0736F	427	HRVT1548T	420	HRVT3048G	425	HRVTC42	410
HRVT0736T	420, 428	HRVT1548W	429	HRVT3048HS2	424	HRVTC48	410
HRVT0742F	427	HRVT1554F	427	HRVT3048M	431	HRVTC54	410
HRVT0742T	420, 428	HRVT1560CK	433	HRVT3048P	428	HRVTC60	410
HRVT0748F	427	HRVT1560E	422	HRVT3048PM	432	HRVTC66	410
HRVT0748T	420, 428	HRVT1560F	427	HRVT3048R	426	HRVTC72	410
HRVT0754F	427	HRVT1560G	425	HRVT3048T	420	HRVTC78	410
HRVT0760F	427	HRVT1560HS2	424	HRVT3060CK	433	HRVTC84	410
HRVT0760T	420, 428	HRVT1560M	431	HRVT3060E	422	HRVTC90	410
HRVT0766F	427	HRVT1560PM	432	HRVT3060G	425	HRVTC96	410
HRVT0772F	427	HRVT1560R	426	HRVT3060HS2	424	HRVTRAYM	431
HRVT0778F	427	HRVT1560T	420	HRVT3060M	431	HRVUP24	546
HRVT0784F	427	HRVT1560W	429	HRVT3060P	428	HRVUP30	546
HRVT0790F	427	HRVT1566F	427	HRVT3060PM	432	HRVUP36	546
HRVT0796F	427	HRVT1572F	427	HRVT3060R	426	HRVUP42	546
HRVT1524CK	433	HRVT1578F	427	HRVT3060T	420	HRVUP48	546
HRVT1524E	422	HRVT1584F	427	HRVT3724E	422	HRVUP60	546
HRVT1524F	427	HRVT1590F	427	HRVT3724HS2	424	HS1100	115, 129, 134, 168, 229, 289, 323, 335, 343, 352, 359, 372, 602, 723, 838
HRVT1524G	425	HRVT1596F	427	HRVT3724T	420	HS1101	115, 129, 134, 168, 229, 289, 323, 335, 343, 352, 359, 372, 602, 723, 838
HRVT1524HS2	424	HRVT2224T	420	HRVT3730E	422	HS1102	115, 129, 134, 168, 229, 289, 323, 335, 343, 352, 359, 372, 602, 723, 838
HRVT1524M	431	HRVT2230T	420	HRVT3730HS2	424	HS30ABC	622
HRVT1524PM	432	HRVT2236T	420	HRVT3730T	420	HS42ABC	622
HRVT1524R	426	HRVT2242T	420	HRVT3736E	422	HS60ABC	622
HRVT1524T	420	HRVT2248T	420	HRVT3736HS2	424	HS72ABC	622
HRVT1524W	429	HRVT2260T	420	HRVT3736T	420	HS82ABC	622
HRVT1530CK	433	HRVT3024CK	433	HRVT3742E	422		
HRVT1530E	422	HRVT3024E	422	HRVT3742HS2	424		
HRVT1530F	427	HRVT3024G	425	HRVT3742T	420		
HRVT1530G	425	HRVT3024HS2	424	HRVT3748E	422		
HRVT1530HS2	424	HRVT3024M	431	HRVT3748HS2	424		
HRVT1530M	431	HRVT3024P	428	HRVT3748T	420		

CROSS REFERENCE INDEX

MODEL	PAGE	MODEL	PAGE	MODEL	PAGE	MODEL	PAGE
HSCI842	623	HSDCDDPA29R	388	HSPH181530BFL(?)	647	HSTBX502424RFFL(?)	520, 638
HSCI872	623	HSDCMP3614	389	HSPH181530BFM(?)	644	HSTBX502424RFFM(?)	518, 636
HSC2472	623	HSDCMP3629	389	HSPM211518BFL(?)	528, 647	HSTBX652424LBBFL(?)	520, 638
HSCABD02	621, 635	HSDCMP4214	389	HSPM211518BFM(?)	526, 644	HSTBX652424LBBFM(?)	518, 636
HSCABD10	621, 635	HSDCMP4229	389	HSPM211524BFL(?)	528, 647	HSTBX652424LFFL(?)	520, 638
HSCACW25	634	HSDCMP4814	389	HSPM211524BFM(?)	526, 644	HSTBX652424LFFM(?)	518, 636
HSCACW35	634	HSDCMP4829	389	HSPM271518BBFL(?)	647	HSTBX652424RBBFL(?)	520, 638
HSCACW50	634	HSDCMP6014	389	HSPM271518BBFM(?)	644	HSTBX652424RBBFM(?)	518, 636
HSCAFD02	621, 635, 676	HSDCMP6029	389	HSPM271518FFL(?)	647	HSTBX652424RFFL(?)	520, 638
HSCAFD10	621, 635, 676	HSDCMP7214	389	HSPM271518FFM(?)	644	HSTBX652424RFFM(?)	518, 636
HSCAHR12	634	HSDCMP7229	389	HSPM271524BBFL(?)	647	HSTBX502424LBBFL(?)	521, 639
HSCAHR15	633	HSDDL29	387	HSPM271524BBFM(?)	644	HSTBX502424LBBFM(?)	519, 637
HSCAPB	634	HSDDPA29L	388	HSPM271524FFL(?)	647	HSTBX502424LFFL(?)	521, 639
HSCAUC1824	517, 635	HSDDPA29R	388	HSPM271524FFM(?)	644	HSTBX502424LFFM(?)	519, 637
HSCAUC1830	517, 635	HSDEPI129F	386	HSPM271530BBFL(?)	647	HSTBX502424RBBFL(?)	521, 639
HSCAUC1836	517, 635	HSDEP2429F	386	HSPM271530BBFM(?)	644	HSTBX502424RBBFM(?)	519, 637
HSCAWS6520	634	HSDEP3029F	386	HSPM271530FFL(?)	647	HSTBX502424RFFL(?)	521, 639
HSCAWS6524	634	HSDG	387	HSPM271530FFM(?)	644	HSTBX502424RFFM(?)	519, 637
HSCAWS6530	634	HSDMP244	389	HSPRAY	854	HSTBX652424LBBFL(?)	521, 639
HSCBX223018BFL(?)	515, 629	HSDMP249	389	HSPSBX281518BBFL(?)	647	HSTBX652424LBBFM(?)	519, 637
HSCBX223018BFM(?)	513, 627	HSDMP304	389	HSPSBX281518BBFM(?)	644	HSTBX652424LFFL(?)	521, 639
HSCBX223018O	513, 627	HSDMP309	389	HSPSBX281518FFL(?)	647	HSTBX652424LFFM(?)	519, 637
HSCBX223618BFL(?)	515, 629	HSDMP364	389	HSPSBX281518FFM(?)	644	HSTBX652424RBBFL(?)	521, 639
HSCBX223618BFM(?)	513, 627	HSDMP369	389	HSPSBX281524BBFL(?)	647	HSTBX652424RBBFM(?)	519, 637
HSCBX223618O	513, 627	HSDMP424	389	HSPSBX281524BBFM(?)	644	HSTBX652424RFFL(?)	521, 639
HSCBX224818LBFOL(?)	515, 629	HSDMP429	389	HSPSBX281524FFL(?)	647	HSTBX652424RFFM(?)	519, 637
HSCBX224818LBFOM(?)	513, 627	HSDMP484	389	HSPSBX281524FFM(?)	644	HSTSF502424LBBFL(?)	524, 642
HSCBX224818RBFOL(?)	515, 629	HSDMP489	389	HSPSBX281530BBFL(?)	647	HSTSF502424LBBFM(?)	522, 640
HSCBX224818RBFOM(?)	513, 627	HSDMP544	389	HSPSBX281530BBFM(?)	644	HSTSF502424LFFL(?)	524, 642
HSCBX226018LBFOL(?)	515, 629	HSDMP549	389	HSPSBX281530FFL(?)	647	HSTSF502424LFFM(?)	522, 640
HSCBX226018LBFOM(?)	513, 627	HSDMP604	389	HSPSBX281530FFM(?)	644	HSTSF502424RBBFL(?)	524, 642
HSCBX226018RBFOL(?)	515, 629	HSDMP609	389	HSPSSF281518BBFL(?)	648	HSTSF502424RBBFM(?)	522, 640
HSCBX226018RBFOM(?)	513, 627	HSDMP664	389	HSPSSF281518BBFM(?)	645	HSTSF502424RFFL(?)	524, 642
HSCBX227218LBFOL(?)	515, 629	HSDMP669	389	HSPSSF281518FFL(?)	648	HSTSF502424RFFM(?)	522, 640
HSCBX227218LBFOM(?)	513, 627	HSDMP724	389	HSPSSF281518FFM(?)	645	HSTSF652424LBBFL(?)	524, 642
HSCBX227218RBFOL(?)	515, 629	HSDMP729	389	HSPSSF281524BBFL(?)	648	HSTSF652424LBBFM(?)	522, 640
HSCBX227218RBFOM(?)	513, 627	HSDRK29	388	HSPSSF281524BBFM(?)	645	HSTSF652424LFFL(?)	524, 642
HSCK24BF	634	HSDSL2429F	386	HSPSSF281524FFL(?)	648	HSTSF652424LFFM(?)	522, 640
HSCK30BF	634	HSDSL29	387	HSPSSF281524FFM(?)	645	HSTSF652424RBBFL(?)	524, 642
HSCK30O	634	HSDSL3029F	386	HSPSSF281530BBFL(?)	648	HSTSF652424RBBFM(?)	522, 640
HSCK36BF	634	HSFCBX283018BBFLA	631	HSPSSF281530BBFM(?)	645	HSTSF652424RFFL(?)	524, 642
HSCK36O	634	HSFCBX283018BBFM(?)	631	HSPSSF281530FFL(?)	648	HSTSF652424RFFM(?)	522, 640
HSCKTPS	457	HSFCSF283018BBFLA	631	HSPSSF281530FFM(?)	645	HSTSSF502424LBBFL(?)	525, 643
HSCSF223018BFL(?)	516, 630	HSFCSF283018BBFM(?)	631	HSS4L-06A	811	HSTSSF502424LBBFM(?)	523, 641
HSCSF223018BFM(?)	514, 628	HSLACW50	633	HSS4L-12A	811	HSTSSF502424LFFL(?)	525, 643
HSCSF223018O	514, 628	HSLACW57	633	HSS4L-14A	811	HSTSSF502424LFFM(?)	523, 641
HSCSF223618BFL(?)	516, 630	HSLBX283018FFLA	632	HSS4L-16B	811	HSTSSF502424RBBFL(?)	525, 643
HSCSF223618BFM(?)	514, 628	HSLBX283018FFM(?)	632	HSS4L-18B	811	HSTSSF502424RBBFM(?)	523, 641
HSCSF223618O	514, 628	HSLBX283618FFLA	632	HSSA-WB1618	812	HSTSSF502424RFFL(?)	525, 643
HSCSF224818LBFOL(?)	516, 630	HSLBX283618FFM(?)	632	HSSCL-14A	813	HSTSSF502424RFFM(?)	523, 641
HSCSF224818LBFOM(?)	514, 628	HLSLF283018FFLA	632	HSSCL-16B	813	HSTSSF652424LBBFL(?)	525, 643
HSCSF224818RBFOL(?)	516, 630	HLSLF283018FFM(?)	632	HSSCL-18B	813	HSTSSF652424LBBFM(?)	523, 641
HSCSF224818RBFOM(?)	514, 628	HLSLF283618FFLA	632	HSSST-18B	814	HSTSSF652424LFFL(?)	525, 643
HSCSF226018LBFOL(?)	516, 630	HLSLF283618FFM(?)	632	HSSTK-18B	814	HSTSSF652424LFFM(?)	523, 641
HSCSF226018LBFOM(?)	514, 628	HSPAK15	645	HSTAKL	525, 643	HSTSSF652424RBBFL(?)	525, 643
HSCSF226018RBFOL(?)	516, 630	HSPFSF221518BFL(?)	529, 648	HSTAKR	525, 643	HSTSSF652424RBBFM(?)	523, 641
HSCSF226018RBFOM(?)	514, 628	HSPFSF221518BFM(?)	527, 645	HSTB2W1	84, 218, 253, 590	HSTSSF652424RFFL(?)	525, 643
HSCSF227218LBFOL(?)	516, 630	HSPFSF221524BFL(?)	529, 648	HSTBX502424LBBFL(?)	520, 638	HSTSSF652424RFFM(?)	523, 641
HSCSF227218LBFOM(?)	514, 628	HSPFSF221524BFM(?)	527, 645	HSTBX502424LBBFM(?)	518, 636	HSWEEPA2	285, 318
HSCSF227218RBFOL(?)	516, 630	HSPH181518BFL(?)	647	HSTBX502424LFFL(?)	520, 638	HSWEEPA3	285, 318
HSCSF227218RBFOM(?)	514, 628	HSPH181518BFM(?)	644	HSTBX502424LFFM(?)	518, 636	HSWEEPC2	285, 318
HSDBK29	388	HSPH181524BFL(?)	647	HSTBX502424RBBFL(?)	520, 638	HSWEEPC3	285, 318
HSDCDDPA29L	388	HSPH181524BFM(?)	644	HSTBX502424RBBFM(?)	518, 636	HT48ND	376

CROSS REFERENCE INDEX

MODEL	PAGE	MODEL	PAGE	MODEL	PAGE	MODEL	PAGE
HT60ND	376	HTLCUBE216	777	HTLR48	778	HVL982	116, 130, 135, 169, 230, 290, 324, 336, 344, 353, 360, 373, 532, 603, 724, 839
HT66ND	376	HTLCUBE240	777	HTLR84	778		
HT72ND	376	HTLCUBE48	779	HTLR96	778	HVL991	116, 130, 135, 169, 230, 290, 324, 336, 344, 353, 360, 373, 532, 603, 724, 839
H-TASCRN2430	852D	HTLCUBE84	777	HTLR108	778		
H-TASCRN2436	852D	HTLCUBE96	777	HTLR120	778		
H-TASCRN2448	852D	HTLCUBEM	777	HTLR144	778		
H-TASCRN3630	852D	HTLCUBES108	777	HTLR168	778	HVPWLK24	84, 253
H-TASCRN3636	852D	HTLCUBES120	777	HTLR180	778	HVPWLK30	84, 253
H-TASCRN3648	852D	HTLCUBES144	777	HTLR192	778	HWC3624P	571
HTBINSLIDE	781	HTLCUBES168	777	HTLR216	778	HWC4224P	571
HTCOL52	70, 160, 280, 317, 333	HTLCUBES180	777	HTLR240	778	HWC4230P	571
HTL(?)3060	774	HTLCUBES192	777	HTLR48	778	HWC4824P	571
HTL(?)36	775	HTLCUBES216	777	HTLR84	778	HWC4830P	571
HTL(?)3672	774	HTLCUBES240	777	HTLR96	778	HWC72	623
HTL(?)42	775	HTLCUBES48	779	HTLR108	778	HWC3624P	572
HTL(?)4284	774	HTLCUBES96	777	HTLR120	778	HWC4224P	572
HTL(?)48	775	HTLCUBESM	777	HTLR144	778	HWC4230P	572
HTL(?)48108	774	HTLHP108	777	HTLR168	778	HWC4824P	572
HTL(?)48120	774	HTLHP120	777	HTLR180	778	HWC4830P	572
HTL(?)48144	774	HTLHP144	777	HTLR192	778	HWD244830P	570
HTL(?)48168	774	HTLHP168	777	HTLR216	778	HWD245430P	570
HTL(?)48180	774	HTLHP180	777	HTLR240	778	HWD246030P	570
HTL(?)48192	774	HTLHP192	777	HTLR48	778	HWD246630P	570
HTL(?)48216	774	HTLHP216	777	HTLR84	778	HWD247230P	570
HTL(?)48240	774	HTLHP240	777	HTLR96	778	HWD304824P	570
HTL(?)4896	774	HTLHP84	777	HTLR108	778	HWD305424P	570
HTL(?)54108	774	HTLHP96	777	HTLR120	778	HWD306024P	570
HTL(?)54120	774	HTLHPM	777	HTLR144	778	HWD306624P	570
HTL(?)54144	774	HTLLECTA	782	HTLR168	778	HWD307224P	570
HTL(?)54168	774	HTLM4872	774	HTLR180	778	HWP306024P	576
HTL(?)54180	774	HTLM5472	774	HTLR192	778	HWP306624P	576
HTL(?)54192	774	HTLM7248P	790	HTLR216	778	HWP307224P	576
HTL(?)54216	774	HTLMC1828DL	782	HTLR240	778	HWP3060P	576
HTL(?)54240	774	HTLMC1828DR	782	HTLR48	778	HWP3066P	576
HTLB1048LP	791	HTLMC1828L	782	HTLR84	778	HWP3072P	576
HTLB12048P	790	HTLMC1828O	782	HTLR96	778	HWR1824P	568
HTLB1248LP	791	HTLMC1828R	782	HTLR108	778	HWR1830P	568
HTLB14448P	790	HTLP108	776	HTLR120	778	HWR1836P	568
HTLB1448LP	791	HTLP120	776	HTLR144	778	HWR1842P	568
HTLB1648LP	791	HTLP144	776	HTLR168	778	HWR1848P	568
HTLB16848P	790	HTLP168	776	HTLR180	778	HWR1854P	568
HTLB1848LP	791	HTLP180	776	HTLR192	778	HWR1860P	568
HTLB2048LP	791	HTLP192	776	HTLR216	778	HWR1866P	568
HTLC4272HCTFP	780	HTLP216	776	HTLR240	778	HWR1872P	568
HTLC4272HCTHP	780	HTLP240	776	HTLR48	778	HWR2424P	568
HTLC4272HCTP	780	HTLP60	776	HTLR84	778	HWR2430P	568
HTLC4272LCTFP	780	HTLP72	776	HTLR96	778	HWR2436P	568
HTLC4272LCTHP	780	HTLP84	776	HTLR108	778	HWR2436PN	489, 490
HTLC4272LCTP	780	HTLP96	776	HTLR120	778	HWR2442P	568
HTLC4296HCTFP	780	HTLPB	790	HTLR144	778	HWR2448P	568
HTLC4296HCTHP	780	HTLPBS	790	HTLR168	778	HWR2448PN	489, 490
HTLC4296HCTP	780	HTLPM	776	HTLR180	778	HWR2454P	568
HTLC4296LCTFP	780	HTLPRES	786	HTLR192	778	HWR2460P	568
HTLC4296LCTHP	780	HTLR108	778	HTLR216	778		
HTLC4296LCTP	780	HTLR120	778	HTLR240	778		
HTLCREDA	781	HTLR144	778	HTLR36	778		
HTLCREDB	781	HTLR168	778	HTLR42	778		
HTLCUBE108	777	HTLR180	778				
HTLCUBE120	777	HTLR192	778				
HTLCUBE144	777	HTLR216	778				
HTLCUBE168	777	HTLR240	778				
HTLCUBE180	777	HTLR36	778				
HTLCUBE192	777	HTLR42	778				
				HV-UT1	527, 593, 680, 846	HWR2424P	568
				HVFB20R	593	HWR2430P	568
				HVFB23R	593	HWR2436P	568
				HVFF20R	593	HWR2436PN	489, 490
				HVFF23R	593	HWR2442P	568
				HVL981	116, 130, 135, 169, 230, 290, 324, 336, 344, 353, 360, 373, 532, 603, 724, 839	HWR2448P	568
						HWR2448PN	489, 490
						HWR2454P	568
						HWR2460P	568

CROSS REFERENCE INDEX

MODEL	PAGE	MODEL	PAGE	MODEL	PAGE	MODEL	PAGE
HWR2460PN	490	HWR3072PN	490	HWV75ABRP	575	HWV95BBRP	575
HWR2466P	568	HWR3084P	569	HWV75BALP	574	SPLH-ABND-GALGLSS.M482171	436
HWR2472P	568	HWSA2	589	HWV75BARP	575	SPLH-ABND-GALGLSS.M482172	436
HWR2472PN	490	HWSB2	589	HWV75BBLP	574	SPLH-ABND-GALGLSS.M482173	436
HWR2484P	568	HWSR24	590	HWV75BBRP	575	SPLH-ABND-GALGLSS.M482174	436
HWR3024P	569	HWSR30	590	HWV93AALP	574	SPLH-ABND-GALGLSS.M482175	436
HWR3030P	569	HWSR36	590	HWV93AARP	575	SPLH-ABND-GALGLSS.M482176	436
HWR3036P	569	HWSR42	590	HWV93BALP	574	SPLH-ABND-GALGLSS.M482177	436
HWR3042P	569	HWSR48	590	HWV93BARP	575	SPLH-ABND-GALGLSS.M482178	436
HWR3048P	569	HWV73AALP	574	HWV95AALP	574	SPLH-ABND-GALGLSS.M482179	436
HWR3048PN	490	HWV73AARP	575	HWV95AARP	575	SPLH-ABND-GALGLSS.M482180	436
HWR3054P	569	HWV73BALP	574	HWV95ABLP	574	SPLH-ABND-GALGLSS.M482181	436
HWR3060P	569	HWV73BARP	575	HWV95ABRP	575	SPLH-ABND-GALGLSS.M482182	436
HWR3060PN	490	HWV75AALP	574	HWV95BALP	574	SPLH-ABND-GALGLSS.M482183	436
HWR3066P	569	HWV75AARP	575	HWV95BARP	575		
HWR3072P	569	HWV75ABLP	574	HWV95BBLP	574		

NOTES

NOTES

NOTES

NOTES

NOTES

NOTES

INFORMATION ON ORDERING PARTS

When parts are needed to repair HON products, the following guidelines should be followed to expedite the process.

1. Warranty orders are submitted on HON Ready via the Quick Claim tool. To purchase repair parts, please visit HONAccessories.com which can be found on HON.com.
2. There are no discounts applied to parts. Pricing quoted is the net value. Parts pricing is subject to change without notice.
3. For a part not covered by warranty applicable shipping charges will apply.
4. All keys are \$6.00 each plus a shipping and handling fee of \$3.00 per shipping location.
5. Parts may be paid for with an approved credit card. Approved Cards: MasterCard, VISA and American Express.
6. Payment terms for invoiced parts are Net 30 days.
7. Due to short leadtimes on parts, no changes will be accepted after the order has been placed.
8. When placing a **warranty** parts order:

If the product is under warranty, the product serial number must be provided. Most finished goods products have a serial number placed on them at the factory. The label containing the serial number is located:

Vertical Files — right side of the uppermost drawer

Lateral Files — left side of the uppermost drawer or shelf

Desk Towers — outside of top drawer

Desks, Credenzas, & Returns — on the outside, kneespace side of the top drawer. Fully extend the drawer to find it.

Desks, Credenzas, Corner Units, Bridges, Peninsulas & Returns without drawers — underside of top

Tables and Stands — underside of the top

Table Trucks — underside of side rail

Cabinets & Bookcases — left inner side of the case

Modular Component Top and Backs — underside of top

Modular End Panels — top inside surface

Reception Stations — top inside surface of back panel

Organizers — top inside surface of left end panel near back panel

Vertical Paper Manager — back panel inside surface near top

Pedestals — bottom drawer right side exterior

Seating — underside of the seat

Panels — underside of the top cap

Hutches, Storage Units, Overhead Storage — underside of the shelf

Hanging Bookshelves — underside of shelf

NOTE: Removal of the serial number tag from the product voids the warranty.

An important note regarding Product Serial Numbers:

HON desks, tables, chairs, files and systems components are tagged with a serial number. This number helps us identify *when and where your product was made*, and to identify and correct the root causes for the problem. NEITHER THE DEALER NOR THE CONSUMER SHOULD REMOVE THIS TAG UNDER ANY CIRCUMSTANCES. To do so immediately voids your Warranty coverage for that particular item *and prevents us from further identifying it*. Instead, please transcribe the number and call your Dealer.

HON

2020 LIST PRICER



SEATING

EFFECTIVE JANUARY, 2020
Supersedes HON List Pricer
Dated June 2019

TABLE OF CONTENTS

By Series Name

BY SERIES NAME

Accommodate®	30-36
Adjustable Task/Lab Stools	37
Assemble™	38
Boda™	39-40
Cambia™ 2160 Series	41-43
Ceres®	44-49
Charge™	50
Circulate™	51
Client™	52
ComforTask® 5900 Series	53-57
Convergence®	58-62
Corral™	63
Contemporary Occasional Tables	64
Crio	65
Define™	66
Endorse® Collection	67-76
Entire™	77
Exposure™	78
Flock®	79-113
Gateway™	114-117
Grove®	118-130
GuestStacker® 4030 Series	131-132
Ignition®	133-156
Instigate™	157
Invitation® 2110 Series	158-161
Invitation® Lounge	162-164
Lota®	165-170
Matter™	171-172
Merit™	173-174
Motivate® Chairs	175-194
Network™	195
Neutralize™	196-197
Nucleus®	198-203
High-Density Olson Stacker® 4040 Series	204-205
Pagoda®	206-213
Park Avenue Collection® 5000 Series	214-216
Park Avenue Collection® 5020 Series	217-219
Perch™	220
Perpetual® Nesting Chairs	221-223
Pillow-Soft® 2090 Series	224-226
Pillow-Soft® 2190 Series	227-229
Prominent™	230-231
Quotient®	232-235
Ryder™	236-237
Scatter™	238
Skip	239-240
SmartLink®	241-247

Solutions Seating® 4000 Series	248-250
Solve®	251-262
Soothe®	263-272
Tilt™	273
TopFlight™	274
Torch™	275
Traction™	276
Validate™	277
ValuTask®	278
Versant® Tandem	279-285
Volt®	286-293
Wave™	294
Executive Chairs	295-297
Guest Chairs	298
Mesh Chairs	299
Nesting Chairs	300
Task Chairs	301
Collaborative Chairs	302
Workplace Tools	303-304

BY APPLICATION

EXECUTIVE AND CONFERENCE

Ceres®	48
Charge™	50
Client™	52
Crio	65
Define™	66
Endorse®	71, 74
Entire™	77
Executive Chairs	295-297
Exposure™	78
Ignition®	140-141
Merit™	174
Nucleus®	202
Park Avenue Collection®	216, 219
Pillow-Soft®	226, 229
Ryder™	237
Solutions Seating®	250
TopFlight™	274
Traction™	276
Validate™	277
Wave™	294

TASK CHAIRS

Boda™	40
Ceres®	48
ComforTask®	56
Convergence®	61-62

Crio	65
Endorse®	72-74
Entire™	77
Exposure™	78
Gateway™	116-117
Ignition®	138-139, 141, 145-150
Lota®	168-169
Mesh Chairs	299
Motivate®	178
Network™	195
Neutralize™	197
Nucleus®	202
Park Avenue Collection®	216, 219
Pillow-Soft®	226, 229
Prominent™	230-231
Quotient®	235
SmartLink®	247
Solutions Seating®	250
Solve®	255, 257, 259, 261
Task Chairs	301
Tilt™	273
Torch™	275
ValuTask®	278
Volt®	288-289, 292-293
Wave™	294

GUEST CHAIRS

Accommodate®	33, 35
Cambia™	43
Ceres®	49
Charge™	50
Client™	52
Flock®	96, 98
Guest Chairs	298
Ignition®	153-155
Instigate™	157
Invitation®	160
Lota®	170
Nucleus®	203
Pagoda®	209-212
Park Avenue Collection®	219
Pillow-Soft®	226, 229
Scatter™	238
Solutions Seating®	250
Soothe®	267-268
TopFlight™	274
Traction™	276
Validate™	277
Versant® Tandem	285

- All illustrations and specifications in this publication are based on the latest product information available at the time of print. For the most recent version, please go to <https://www.hon.com/pricer>.
- Software support packages furnished to the customer, either by The HON Company or by another source, which support the sale of HON products are superseded by printed price lists.
- All dimensions shown in this publication are nominal.
- Pricing is subject to change without notice.

- All orders are subject to prices in effect at the time of order.
- Ordering information appears at the beginning of a section complete with examples on how to specify. These specifying information pages are referenced at the bottom center of product pages.
- HON Full Lifetime Warranty applies unless otherwise noted.
- HON nationwide customer service:
Phone: (800) 833-3964.

TABLE OF CONTENTS

By Series Name

BY APPLICATION

STACKING AND NESTING CHAIRS

Assemble™	38
Ceres®	49
GuestStacker®	132
Ignition®	154-155
Lota®	170
Mesh Nesting Chairs	300
Motivate®	180, 184, 188
Nucleus®	203
High-Density Olson Stacker®	205
Pagoda®	209-212
Perpetual®	223
SmartLink®	244-246

COLLABORATIVE AND PUBLIC SPACES

Accommodate®	33-36
Circulate™	51
Collaborative Chairs	302
Corral™	63
Flock®	83-92, 96-99, 102-103
Grove®	122-124, 126-129
Ignition®	153
Invitation® Lounge	164
Skip	240
Soothe®	267-270
Versant® Tandem	283, 285

STOOLS AND MULTI-PURPOSE

Accommodate®	33-36
Adjustable Task/Lab	37
Ceres®	49
ComforTask®	57
Endorse®	75
Flock®	96, 98
Ignition®	141, 145, 147, 154, 156
Instigate™	157
Lota®	170
Matter™	172
Motivate®	178, 184-185, 188, 191, 194
Nucleus®	203
Pagoda®	213
Perch™	220
Perpetual®	223
Prominent™	230-231
Quotient®	235
SmartLink®	247
Solve®	256, 258, 260
Torch™	275
ValuTask®	278
Volt®	288-289, 292-293

ACTIVE

Perch™	220
Tilt™	273
Workplace Tools	303-304

BIG AND TALL

Crio	65
Endorse®	74
Ignition®	141
Wave™	294

BARIATRIC

Accommodate®	34, 36
Ignition®	153
Soothe®	267, 269
Versant® Tandem	285

COORDINATING TABLES

Contemporary Occasional Tables	64
Flock®	107-112
Invitation®	161
Soothe®	271
Versant® Tandem	284

WORKPLACE TOOLS

Workplace Tools	303-304
-----------------	---------

- All illustrations and specifications in this publication are based on the latest product information available at the time of print. For the most recent version, please go to hon.com/tools-ideas/resources/pricer.
- Software support packages furnished to the customer, either by The HON Company or by another source, which support the sale of HON products are superseded by printed price lists.
- All dimensions shown in this publication are nominal.
- Pricing is subject to change without notice.

- All orders are subject to prices in effect at the time of order.
- Ordering information appears at the beginning of a section complete with examples on how to specify. These specifying information pages are referenced at the bottom center of product pages.
- HON Full Lifetime Warranty applies unless otherwise noted.
- HON nationwide customer service:
Phone: (800) 833-3964.

ADDITIONS

NEW ADDITIONS: PRODUCTS

Seating	Effective Date
Flock® Models: HFCL2, HFCL2DF, HFLSC2, HFLSC2DF	October 23, 2019
Flock® Models: HFLB2, HFLB3, HTSSRD	November 5, 2019
Ignition® 2.0 Models: HIWMU, HIWMUKD	June 28, 2019
Ignition® 2.0 Models: HITLRAKD, HIWMRAKD, HIWMUL, HIWMULKD	August 27, 2019
Matter™ Models: HVL232, HVL238	January 1, 2020
Merit™ Model: HME3	January 1, 2020
Neutralize™ Model: HVL791	January 1, 2020
Ryder™ Model: HVL149	January 1, 2020

DISCONTINUATIONS

Seating	Effective Date	Fabrics and Finishes	Effective Date
Assemble™ Models: HBMPT6024P, HBMPT60MOD, HBMPT7224P, HBMPT72MOD	December 31, 2019	Seating Fabric ASF90 (HVLPERCH)	June 30, 2020
Flock® Models: HFCL1, HFCL1DF, HFLCO1T, HFLCO1TDF, HFLYO1T, HFLYO1TDF	December 31, 2019	ASF42 (HVLPERCH)	December 31, 2019
HVL Models Models: HVL601.VA19 & HVL601.VA62 only	December 31, 2019	ASF82 (HVLPERCH)	December 31, 2019
Pagoda® Model: HUCART	2018	GA42 (H5701)	June 30, 2020
Pillow-Soft® Model: H2095.H.PWST90.T only	December 31, 2019	Denver Leather	December 31, 2019
Prominent™ Model: HVL530	June 30, 2020	Black SS11	
Purpose® Models: HR1P, HR1S, HR1W, HR5P, HR5S, HR5W, HRAAP, HRFAP	June 30, 2019	Select Models Only: Endorse® Models HLTM, HLTMFC, HLTSM, HLTSMFC, HLWMBT, HLWMBTFC	
Riley™ Models: HWGN1, HWGN1B, HWGN5, HWGN5B	December 31, 2019	Flock® HFSS7	
Volt® Model: H5711.GA90.T only	December 31, 2019	Ignition® Models HIB50, HIB50FC, HITL1, HITL1FC, HITL2, HITL2FC, HITL3, HITL3FC, HITS5, HITS5FC, HIWM8, HIWM8FC	
Workplace Tools Models: H1706, H2107, H2516, H5210, H5220, HCPU	June 30, 2020	Motivate® HMG2, HMG4, HMG7, HMGT2, HMN2, HMN2FC, HMNT2, HMNT2FC, HMS2, HMT1, HMT1FC, HMT5, HMT5FC	
		Nucleus® HN6, HN6FC	
		Inertia	June 1, 2019
		Bronze NR28	
		Clover NR74	
		Mulberry NR60	
		Tectonic	December 31, 2019
		Black NT10	
		Charcoal NT19	
		Chive NT78	
		Mariner NT90	
		Periwinkle NT85	
		Taupe NT26	
		Wine NT69	

HON FULL LIFETIME WARRANTY INFORMATION



FULL LIFETIME WARRANTY

YOUR HON FULL LIFETIME WARRANTY

Every time you purchase a HON product, you're making an investment in your future. We're proud to play a part in that future, and you can trust us to do our best for as long as you need us.

The HON Full Lifetime Warranty is our assurance to you that the HON desks, workstations, seating, tables, or storage you purchase will be free from defective material or workmanship for the life of the product.

In the unlikely event that any HON product or component covered by the HON Full Lifetime Warranty should fail under normal workplace use as a result of defective material or workmanship, HON shall repair or replace with comparable product (at HON's discretion), free of charge.

WHAT'S COVERED BY THE HON FULL LIFETIME WARRANTY?

Your HON Full Lifetime Warranty applies to product manufactured after January 1, 2011. All HON product lines, materials, and components are covered by the HON Full Lifetime Warranty except for the items described below.

The specific product lines, materials, and components listed below are covered under HON's Full 12-Year, Full 10-Year, and Full 5-Year Warranties (from date of purchase).

HON'S FULL 12-YEAR WARRANTY

- Electrical components (LED task lights, lamps and ballasts are not covered)
- 4-Way Stretch Mesh
- Seating controls
- Pneumatic Cylinders
- Wood Seating
- Accessories
- Laminate Surfaces
- Veneer Surfaces

HON'S FULL 10-YEAR WARRANTY

- Soothe® Patient Recliner Mechanism

HON'S FULL 7-YEAR WARRANTY

- Coordinate™ Height Adjustable Bases

HON'S FULL 5-YEAR WARRANTY

- All LED task lights
- Panel and seating textiles
- Electric Height Adjustable Bases (Including Memory Control)
- Coordinate™ Desktop Sit-to-Stand Risers
- Soothe® Patient Recliner Central Lock Mechanism
- Soothe® Patient Recliner Pivoting Arm
- Between™ Multi-Purpose Table
- Acoustic Solutions by Unika Vaev

These warranties apply to HON products sold within the United States of America, U.S. Territories, and Canada, as well as U.S. Military and Federal Agency purchases (regardless of location).

IS ANYTHING NOT COVERED?

There are a few exclusions to the HON Full Lifetime Warranty and to the 12-, 10-, and 5-year warranties. These exclusions are:

- All HON products that are covered under a separate 5-year warranty.
- Color-fastness or matching of colors, woodgrains, or textures occurring in wood, leather, or other materials that naturally exhibit inherent color variations.
- Customer's own materials (COM) selected by and used at the request of the user.
- Modifications or attachments to the product that are not approved by The HON Company and product failures resulting from such modifications or attachments.
- Product normal wear and tear, which are to be expected over the course of ownership.
- Products that were not installed, used, or maintained in accordance with product instructions and warnings.
- Products used for rental purposes.
- Damage caused by cleaning chemicals.
- Dye transfer caused by external contaminants (including clothing and accessory dyes such as those used on denim jeans) may migrate to lighter colors. This phenomenon is increased by humidity and temperature and is irreversible.
- Fabric pattern match seat to back or chair to chair. If pattern match is needed, please submit a Tailored Solutions request or contact HON Customer Support/Tailored Solutions with questions.

WARRANTY REQUESTS OR QUESTIONS?

Your HON Dealer is our mutual partner in supporting your warranty requests. To obtain service under this warranty, please contact your HON dealer. If you are not sure who your dealer is, please call HON Customer Support at 800.833.3964.

THAT'S YOUR HON FULL LIFETIME WARRANTY AS AN OWNER OF HON PRODUCT, THE WARRANTY EXPLAINED HERE IS YOUR SOLE AND EXCLUSIVE REMEDY. THERE ARE SOME EXCEPTIONS IF YOU PURCHASED THE PRODUCT FOR HOME OR PERSONAL USE WHICH ARE EXPLAINED BELOW. TO THE EXTENT ALLOWED BY LAW, THE HON COMPANY MAKES NO OTHER WARRANTY, EITHER EXPRESS OR IMPLIED, INCLUDING ANY WARRANTY OF MERCHANTABILITY OR FITNESS FOR A PARTICULAR PURPOSE. THE HON COMPANY WILL NOT BE LIABLE FOR ANY CONSEQUENTIAL OR INCIDENTAL DAMAGES.

A WORD ABOUT PURCHASES FOR HOME OR PERSONAL USE

Please note, this section only applies if you purchased your HON product for your home or for your own personal or family use. HON's warranties give you specific legal rights and you may have other rights, which vary from state to state. As a consumer purchaser, the complete exclusion of implied warranties noted in the above paragraph does not apply to you, however, to the extent allowed by applicable state law, the implied warranties are limited to the applicable term of the warranty. Some states do not allow the exclusion or limitation of incidental or consequential damages, so the above exclusion or limitation may not apply to you.

HON LIMITED 5-YEAR WARRANTY INFORMATION

HON[®]

LIMITED 5-YEAR WARRANTY

The HON Company promises to repair or replace HON products or components covered under this warranty that are found to be defective in material or workmanship within five (5) years from the date of original purchase so long as you, the original purchaser, still owns it. This is your sole and exclusive remedy. This warranty is subject to the provisions below. It applies to the products listed here manufactured after January 1, 2018.

LIMITATIONS:

- Upholstery on chairs is warranted for two years from date of purchase.
- Damage caused by the carrier in-transit is handled under separate terms.

EXCLUSIONS:

This warranty does not apply and no other warranty applies to:

- Normal wear and tear, which are to be expected over the course of ownership.
- Modifications or attachments to the product that are not approved by The HON Company.
- Products that were not installed, used or maintained in accordance with product instructions and warnings.
- Products used for rental purposes.

SEATING USAGE

Normal commercial use for seating is identified as the equivalent of a single shift, forty-(40) hour workweek. To the extent that a seating product is used in a manner exceeding this, the applicable warranty period will be reduced in a pro-rata manner.

A WORD ABOUT COLOR VARIATIONS, FABRICS AND FINISHES:

The HON Company does not warrant the color-fastness or matching of colors, grains or textures of covering materials.

CUSTOMER'S OWN MATERIAL (COM)

Not available on HON products covered under the HON 5-year warranty.

TO THE EXTENT ALLOWED BY LAW, THE HON COMPANY MAKES NO OTHER WARRANTY, EITHER EXPRESS OR IMPLIED, INCLUDING ANY WARRANTY OF MERCHANTABILITY OR FITNESS FOR A PARTICULAR PURPOSE. THE HON COMPANY WILL NOT BE LIABLE FOR ANY CONSEQUENTIAL OR INCIDENTAL DAMAGES.

NOTICE TO PURCHASERS FOR HOME OR PERSONAL USE:

Federal law does not permit the exclusion of certain implied warranties for consumer products. Therefore, if you are purchasing this product for home or personal use, the exclusion of implied warranties noted in the above paragraph does not apply to you. Some states do not allow the exclusion or limitation of incidental or consequential damages, so the above limitation or exclusion may not apply to you. This warranty gives you specific legal rights, and you may also have other rights which vary from state to state.

This warranty applies only to products sold within the United States of America and the Commonwealth of Canada.

TO OBTAIN SERVICE UNDER THIS WARRANTY:

Your HON[®] Dealer is our mutual partner in supporting your warranty requests. By following the procedures outlined below, you can be assured of the best level of service. Please note: Consent of The HON Company must be obtained before any warranty work is performed. To obtain consent, please take the following steps:

1. Contact the Dealer from whom the product was purchased within 30 days of discovery of the defect. Be prepared to affirm that you are the original purchaser of the product and to provide the serial number(s) from the product in question.
2. Your Dealer will gather all pertinent information regarding the claim, inspect the product and contact a HON Company customer service representative. (Please allow a reasonable amount of time for inspection and review.)
3. If The HON Company affirms that the product in question is eligible under the conditions of the warranty as stated above, the customer service representative or another representative of the Company will determine whether to provide replacement parts, authorize repairs or replace the product.

ORDERING

Electronic ordering is the standard order process for HON. HON supports the following primary methods for the electronic transmission of orders and order related documents:

Electronic Ordering

Available in the HONReady portal at honready.hon.com. There are multiple options available for processing orders electronically.

Integration with the standard Office Furniture business systems or other pre-approved proprietary software packages.

SIF file upload using fully optioned SIF files into the electronic ordering applications.

Manual entry of line items into the electronic ordering application.

EDI-System to System Integration

With standard Office Product systems or other pre-approved proprietary software systems.

Training, technical set-up and support is available through our Dealer Operations Team at honready@honcompany.com.

ORDER REQUIREMENTS

- Customer must provide complete and correct information, including complete model number, finishes, colors, options, and quantity.
- If a bid quotation or other special pricing applies, such information must be clearly stated on the order with applicable bid number or contract number.
- Order Management contact name and phone number.
- Delivery Appointment contact name and phone number at the dealership or installation company. HON does not accept orders with end user appointment contacts.
- Dealer Sales Representative, primary or multiple DSRs.
- “Best Date Available” for the entire order is standard service for HON. If eligible, other Date Requests may be requested and must be submitted with the order. Other Date Requests are subject to review by HON prior to acceptance:
 - “Ship After” requests are eligible on all order sizes
 - “Deliver On” requests are eligible for full truckload orders
- Additional services outside of HON’s standard services may be available through HON’s ‘Enhanced Services’ for a corresponding fee. Requested services from ‘Enhanced Services’ must be provided at time of order placement.
- The Company reserves the right to require electronic orders or charge \$50 fee per Purchase Order (PO) for manual order processing.
- Failure to provide complete and accurate information results in delayed order entry and acknowledgment. Incomplete orders will not be produced and will be returned to Dealer for correction.

ACKNOWLEDGMENT SERVICE

- E-mailed acknowledgments are available by customer request.
- An acknowledgment will be emailed the morning of the next business day, unless order is placed on credit or other order hold.
- The order will not receive an acknowledged shipment date until all order holds are released.

ORDER CHANGES OR CANCELLATIONS

For Order Changes or Cancellations, please contact Customer Support at 800-833-3964 or email OrderChanges@honcompany.com.

TERMS AND CONDITIONS

See **HON NOW** on honready.hon.com for more information about HON NOW delivery, services and ordering information.

INTEGRATED DESIGN SOLUTIONS

HON INTEGRATED DESIGN SOLUTIONS

Need design assistance? We can help! Our expert design staff will create a professional design package that is sure to put you one step ahead of the competition. And the best part is – it's free!

AUDIT

We will check your drawing and parts list for accuracy. We verify quantity, specification accuracy, product compatibility and structural support.

PLAN & SPECIFY

We will provide a professional design package including a CAD furniture plan, 3-D line drawing and complete parts list based on the rough sketch and work order forms you supply.

VALUE ENGINEERING

We will optimize workstation layouts and propose potential cost saving measures to help your customer save money and make you more competitive and profitable.

RENDERING

We will create a photo realistic rendering of your furniture plan to help your customer visualize what their desired office space will look like.

*SPACE PLANNING (BILLABLE SERVICE)

Let our team do the creative work for you. Our low rates and expert staff will create a furniture layout and design that best suits your customer.

PLANNING TYPICALS

Quick planning ideas to share with your clients. Various settings showcasing desks, tables and workstations available in multiple formats. View them today under Design Resources on the HON Ready Portal.

CONTACT INTEGRATED DESIGN SOLUTIONS

Questions? Please reach out to your region's dedicated designer. Not sure how to reach your designer? Send us a note at the email below.

E-Mail: integrateddesign@honcompany.com



Solve® Chair shown with Coordinate™ Height-Adjustable Table.

MyProjects

A place for all HON Project Services

MyProjects provides one platform to access the full portfolio of HON services including:

- Plan & Specify
- Audit
- Product Modification
- Special Laminates
- Value Engineering
- Rendering
- Customer's Own Material
- Dual Fabric Applications
- Space Planning
- Special Paints
- Project Bid Pricing

Submit your request on the HON Ready Portal at honready.hon.com, MyProjects.

MyProjects Lead Time: 1-3 business days depending on complexity and size of your project.

TAILORED SOLUTIONS ORDERING INFORMATION

PRODUCT MODIFICATIONS

Modifications include structural and dimensional modifications to existing product and Dual Fabric Applications, when standard model is not available.

The HON Company, at its own discretion, may modify standard products to meet specific needs. Product specials can be requested on HON brand product only.

List prices contained in published list pricers are for standard catalog items only. Changes or alterations to catalog items other than those listed as catalog options are subject to additional charges. Pricing will only be furnished upon approval of the special request.

Requests to have the product produced in more than one fabric (e.g., fabric on the seat is different than the fabric on the back), are considered a Dual Fabric Applications request and follow the Product Modification request process within MyProjects.

SPECIAL LAMINATES

Special laminates include requests for laminates not available as part of The HON Company's standard offering. Requests for special laminates are subject to manufacturing approval and minimum order quantities. The HON Company approved special laminates will be subject to a designated upcharge per unit.

Requests for special laminates should be submitted through the MyProjects Application on the HON Ready portal. Pricing will only be furnished upon approval of the special request.

SPECIAL PAINTS

- The HON Company's paint matching equipment can match almost any color, excluding some metallic and whites.
- Special paint requests must be submitted on the HON Ready Portal MyProjects application.
- In order to request a paint sample, the customer must have a minimum order of 10 like product units. Any requests with less than that amount will not be processed.
 - For each new paint request, there will be a \$500 net charge. A sample of the exact color desired is required for matching and approval. The HON Company will match the color and provide a production sample for the customer to review and approve.
 - If the customer is requesting a paint that has been previously matched, a painted match sample is provided with a \$100 net charge.

- Once the signed paint sample is received at The HON Company, the request will be approved.
- Each unique color or finish combination incurs a designated upcharge per color per order (all standard discounts/competitive project pricing applies).

Special note: Some special colors could fall outside of this program due to production costs or not meeting The HON Company's quality standards. The HON Company may apply additional charges to some colors which are costly to apply, and refuse some orders on colors that cannot meet The HON Company's high quality standards. The HON Company will notify the customer upon completion of The HON Company's evaluation if a change in price is required or rejection of the order.

DISCONTINUED PRODUCT

Requests for discontinued product require engineering evaluation, safety review, and testing to current standards prior to approval. Many discontinued products are not available for order. Requests for discontinued products should be submitted through the MyProjects Application on the HON Ready portal.

LEAD TIMES FOR SPECIALS PRODUCT

Lead times on orders containing specials are subject to production capacity and material availability. When possible, the customer should order special products separately to avoid extended lead times for standard products. Extended lead times will be noted on the specials request.

CHANGES TO SPECIALS PRODUCT

A special model will be provided for each approved special item to process orders. Once an order is placed, no changes or cancellations can be made to the order without approval from Tailored Solutions.

CONTACT TAILORED SOLUTIONS

Phone: 800.833.3964 and listen for Tailored Solutions offering on the menu.

Email: HONSpecials@honcompany.com

CUSTOMER'S OWN MATERIAL ORDERING INFORMATION

CUSTOMER'S OWN MATERIAL (COM) PROGRAM

Customer's Own Material (COM) is a request to use fabrics not available as part of HON's standard fabric offering. Manufacture to Supply (MTS) and Dealer to Supply (DTS) are the two ordering methods. The HON Company has partnered with fabric manufacturers to provide competitive pricing and selection through the MTS program. MTS will be the standard offering unless The HON Company is unable to procure the fabric. If there is a DTS request submitted, The HON Company will advise at the time of the request if DTS is available.

CUSTOMER WARRANTY EXCLUSION

The HON Company shall have no responsibility for the condition, quality, value, performance, physical properties, or any other aspects of the COM.

The HON Company shall have no liability for any damages, injuries, or losses to the customer or to any third party that shall be caused by any COM or product modification, and the customer shall hold The HON Company harmless for all liability.

The HON Company assumes no responsibility for the overall appearance, flammability, normal durability, colorfastness, or any other quality of the COM or product modification after its application on a HON product beyond normal quality standards. The HON Company reserves the right to reject a COM fabric if the quality of the COM is not satisfactory for the product. Should this occur, the customer will be notified with an explanation of the issue.

The HON Company is not responsible for fabric that has become obsolete at the COM supplier, that is of poor quality, or that is delivered late to The HON Company from the COM supplier. The HON Company is not responsible for excess yardage created by DTS orders and reserves the right to dispose of the excess fabric.

As a standard HON does not pattern match any standard, partnership or COM fabric, therefore pattern match is not applicable under warranty. If pattern match is needed please submit a Tailored Solutions request or contact HON Customer Support/Tailored Solutions once your COM has been approved.

COM TESTING

As a result of recent legal requirements, The HON Company will need to obtain specific information from the fabric supplier about treatments and chemicals used in the fabric. To the extent the supplier is unwilling or unable to provide the necessary information, which could extend the testing lead time of the request.

To check if a COM has been tested previously, utilize the COM Search Tool on the HON Ready Portal > Design Resources > Textiles & Finishes section using the following information:

- COM Supplier's Name
- Fabric Pattern Name
- Color Name
- If the COM fabric has been tested and previously approved, the COM will not need to be re-tested unless testing

standards have changed, fabric is to be used on a different series, or direction of the fabric has changed from what was previously approved. Please note that Panel product must be approved for each model and color.

- If the pattern has previously been tested and approved, but not in the specific requested color, the customer will need to request an order code for that color only. No further testing will be necessary since the pattern has already been approved.

If the fabric has not previously been tested, the customer must enter the COM request on the HON Ready Portal > Textiles & Finishes > COM Search Tool.

Complete the Supplier Name, Pattern, and Color drop-down fields. For quicker results in these fields, type the first letter of the (supplier, pattern, color) name and, when done, click Add and then Submit. (Multiple series can be added to the same request if they are the same supplier, pattern, and color.)

An email will be sent to the requestor stating the COM Request was successfully submitted. Up to four emails could be received: submitted, in testing, testing materials requested, and final approval/denial with price grade and fabric code. The testing process takes approximately 48 hours.

COM yardage in the pricer is shown as pattern cut only.

COM TESTING — CAL 133 TESTING INFORMATION

The customer is responsible for ensuring that the COM fabric is certified to meet all flame-retardant requirements. All COM seating fabric must, at minimum, meet CAL 117 requirements. If the customer requires the chair be tested to meet the fire safety standards of CAL 133, additional testing and information is required.

All CAL 133 requests must be submitted through the MyProjects application on the HON Ready Portal. Each request must be entered separately since each request will need to be tested individually.

Once the supplier provides the requirements to The HON Company, testing will begin. The customer will receive approval or denial information upon completion of testing.

If the test is approved, a specific model number including "FC" at the end will be provided with an appropriate price.

MTS COM

As previously mentioned, MTS is the primary COM method.

If the COM fabric has not been tested, a COM request must be submitted on the HON Ready Portal.

For MTS orders, The HON Company will procure fabric needed for production. Should The HON Company not be able to obtain fabric yardage, the customer will be contacted.

CUSTOMER'S OWN MATERIAL ORDERING INFORMATION

When testing has been completed, the customer will be notified by the COM team of the test results. If the COM is approved, The HON Company will provide a COM tracking order code for MTS. That tracking code is required on the order in place of the standard fabric code.

If approved, MTS product will be assigned an appropriate fabric grade for pricing. The pricing can be found on the HON Ready Portal > Design Resources > Textiles & Finishes. (All standard discounts/competitive project pricing applies).

Written COM price quotes are valid for 90 days after the issue date.

DTS COM

DTS COM is only available if the COM fabric cannot be procured by The HON Company. If the fabric can be procured by The HON Company, the customer will be contacted to switch to MTS or cancel the request.

If your fabric is not listed as approved, and it is not a Partnership fabric you may request a "Dealer to Supply" code. Select the "Request COM Test" link on the COM Search website. Complete the Supplier Name, Pattern, and Color drop-down fields. For quicker results in these fields, type the first letter of the (supplier, pattern, color) name and, when done, click Add and then Submit. (Multiple series can be added to the same request if they are the same supplier, pattern, and color.)

An email will be sent to the requestor stating the COM Request was successfully submitted. Up to four emails could be received: submitted, in testing, testing materials requested, and final approval/denial with price grade and fabric code. It's rare actual test yardage is required. Testing is mainly done by reviewing the attributes of the fabric. The testing process takes approximately 48 hours.

If the COM has not been tested, a COM request must be submitted on the HON Ready Portal > Design Resources > Textiles & Finishes.

When testing has been completed, the customer will be notified by the COM team of the test results. If the COM is approved, The HON Company will provide a COM tracking order code. That tracking code is required on the order in the place of the standard fabric code.

DTS product is priced at the following grades (all standard discounts/competitive project pricing applies):

- Chairs are a Grade 4
- Panel product is a Grade D

Written COM price quotes are valid for 90 days after the issue date.

COM LEAD TIME

Ship dates will be based on fabric receipt and The HON Company's standard lead time. All fabric must be properly tagged and shipped to the appropriate producing location (provided in the approval email).

- Specific to DTS orders, COM orders will not receive a ship (acknowledged) date until The HON Company has the fabric in its possession for production.
- Specific to DTS orders, the customer may send the required yardage for the order to the address listed on the approval email to arrive no sooner than 4 weeks in advance of the acknowledgment date.

HON will make every effort to locate mis-directed COM shipments on behalf of the customer. However, The HON Company will not be responsible for any COM received without a tracking number or incorrectly shipped by the fabric vendor to an incorrect producing facility.

COM ORDERING INFORMATION

The following information must appear on or accompany the product purchase order:

- Approval tracking number and the customer's purchase order number
- COM supplier, pattern, and color name/number

The packing list for the COM must include the following information when The HON Company receives the shipment for production:

- Dealer or Wholesaler Name
- Purchase order number submitted to The HON Company
- Fabric name
- Yardage shipped
- Approval ordering code

If The HON Company receives fabric with incorrect labeling that cannot be linked to an order, The HON Company will hold the fabric for up to 7 days while the COM team attempts to identify the order. After 7 days, The HON Company will return the fabric to the sender.

Specific to DTS orders; the customer should send only the amount needed for the order. Excess yardage will be disposed of at The HON Company's discretion.

CHANGES TO COM PRODUCT

Once a COM product is ordered, no changes or cancellations can be made to the COM product without approval from the HON COM team.

CONTACT COM TEAM

Phone: 800.833.3964 and listen for COM TEAM offering on the menu.

COM Email: HONCOMTeam@honcompany.com

PARTNERSHIP TEXTILE INFORMATION

Partnership Textiles is the result of The HON Company's partnership with textile industry leaders Camira, Maharam, Stinson, and Ultrafabrics, LLC. The extensive collection of design-driven textiles create a superior offering at a great value. Partnership Textiles significantly updates HON's offering, expanding it with fresh and exciting options.

- **Fabric Warranty:** Partnership Textiles are covered by HON's Full Lifetime Warranty.
- **Lead Times:** Orders specified with Partnership Textiles will be acknowledged based on the supplier's availability and delivery schedule.
- **Availability:** The HON Company will regularly introduce new Partnership Textiles and reserves the right to change the offering at any time.
- **Fabric Cards:** A curated set of Partnership Textiles are carded jointly by HON and the supplier.

Camira

- Blazer

Maharam

- Apt
- Bluff
- Collection 1
- Lariat
- Meld
- 6M

Stinson

- Edge
- Flow
- Reliance IV
- Square One

Ultrafabrics, LLC

- Brisa
- Ultraleather Pro

Fabric Memo Samples: Please contact the supplier directly:

Camira: memos@camirafabrics.com

Maharam: (800) 645-3943

Stinson: (800) 841-6279

Ultrafabrics: (877) 309-6648

HON BRANDED, PARTNERSHIP AND COM PATTERN MATCH

- **Seat to Back Pattern Match** provides alignment of patterns or stripes on chair front surfaces. Additional yardage may be required depending on pattern repeat. If Seat to Back Pattern Match is needed, please contact HON Customer Support/Tailored Solutions. Upcharges are limited to the following product series: Flock® Collaborative Seating, Grove® Seating, Invitation® Lounge Seating, Soothe® Seating.

Single Chair	\$45.00 ea. list upcharge
Two-seat Chair	\$60.00 ea. list upcharge
Three-seat Chair	\$75.00 ea. list upcharge
- **Chair to Chair Pattern Match** provides identical pattern alignment from unit to unit and is available with an upcharge. Chair to Chair Pattern Match is reviewed on a case by case basis as several factors are reviewed to determine additional yardage required, including repeat and pattern direction. If Chair to Chair Pattern Match is needed, please contact HON Customer Support/Tailored Solutions.



ENVIRONMENTAL STATEMENT

Clearing the air.

In 2006, The HON Company became one of the first office furniture manufacturers to have products certified under the Indoor Advantage™ program. Virtually all manufactured products emit chemical compounds into the air. Indoor Advantage™ certification helps assure customers that certified products will help improve the air quality within their offices and workspaces.

Developed by SCS Global Services, Indoor Advantage™ evaluates products against indoor air quality standards, like ANSI/BIFMA Furniture Emissions Standard, X7.1. The ANSI/BIFMA X7.1 standard allows manufacturers to test individual components, as well as complete products for emissions from volatile organic compounds (VOCs). This allows us to identify problematic materials and phase them out of our products.

Indoor Advantage™ certified products meet the LEED v4 credits for low-emitting materials.

Indoor Advantage™ offers two levels of certification, including Indoor Advantage™ and Indoor Advantage™ Gold.



On the level®.

LEVEL®, the certification program for the BIFMA e3 Sustainability Standard, was developed in response to increasing demand for proof that manufacturers were living up to their environmental claims. LEVEL® is a multi-attribute sustainability certification label for products that have met criteria in four categories of impact: Materials, Energy and Atmosphere, Human and Ecosystem Health, and Social Responsibility.

LEVEL® offers three levels of certification:



Products that meet these specifications are identified throughout this publication with the following icons:

Certified SCS Indoor Advantage™



LEVEL® certified to the BIFMA e3 Sustainability Standard

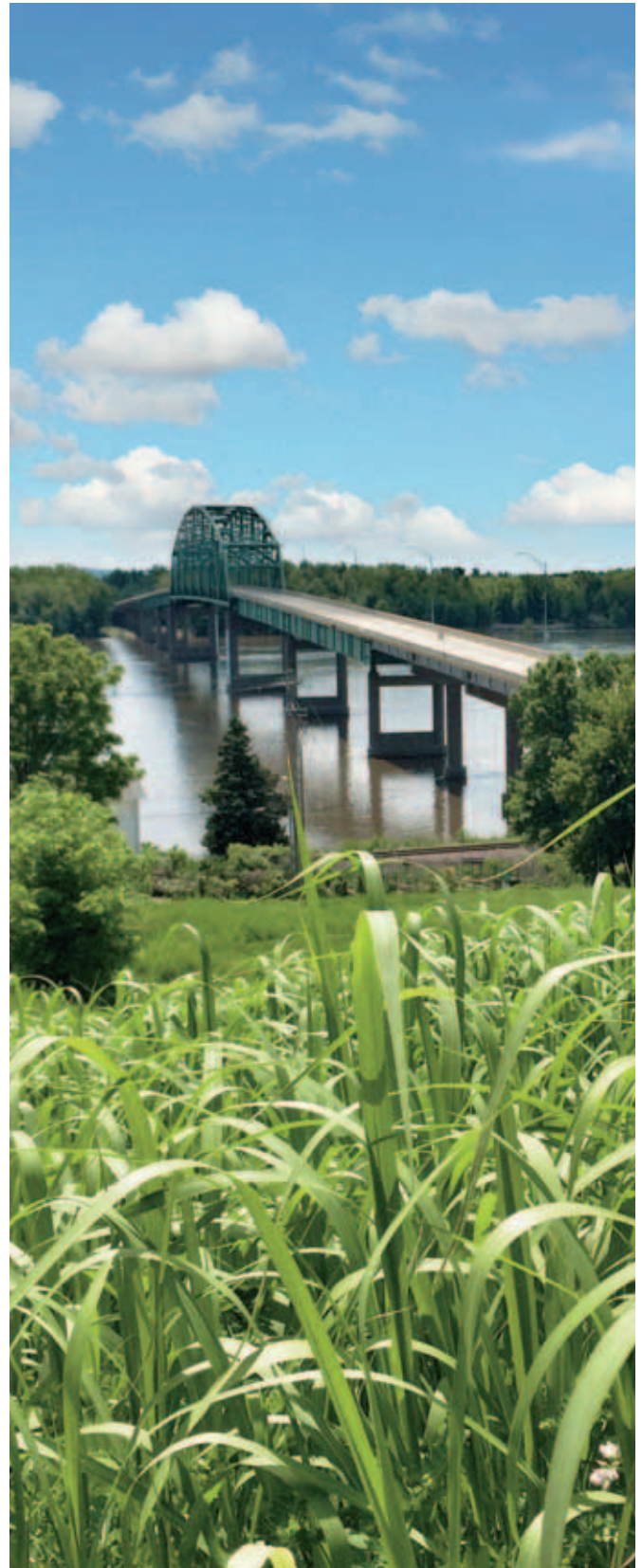

IMPORTANT INFORMATION

HON NOW™

We are inspired by the way you work. The chair you sit in. The space you choose to get it all done. We believe that well-designed office furniture should not only look good but be delivered quickly. Why wait for what you want and what you need right **NOW**?

HON NOW™ offers you a simple way to get the office solutions you need delivered with speed in mind. The office is changing and we are here to help you keep pace. No matter what space you are shopping for or product you need, HON NOW™ is made for the way you work.

GSA CONTRACT INFORMATION

Model numbers identified with the verbiage “**Open Market**” are not offered on HON’s GSA contract GS-27F-0015S. Model numbers identified with the following verbiage “Must be purchased with a configurable end product. If ordered separately, not on GSA contract” is to mean that these configurable components or options:

- Have no functionality or capability without being integrated into an end product, and
- Are not separately orderable; an eligible Schedule ordering activity may only purchase them with a configured system that is on contract.

HON CUSTOMER SUPPORT CONTACT INFORMATION

Nationwide CS Phone – (800) 833-3964

Nationwide Product Solutions Team/Phone – (800) 336-8398

Nationwide Order Entry – email: HONOE@honcompany.com

Government CS Phone – (800) 466-8694

GSA Team: HONGSATEAM@honcompany.com

GSA Order Entry: HONGSAOE@honcompany.com

Integrated Design Solutions – (800) 433-7264

HON Online Order Support – HONReady@honcompany.com

DASH (transportation and delivery assistance) – (800) 334-8057

HON Literature Fulfillment Phone – (800) 466-4808

HON Literature Fulfillment Fax – (800) 466-1865



Nationwide CS Phone

800-833-3964

THE FOLLOWING ICONS ARE USED THROUGHOUT THIS PUBLICATION

- 

Meets or exceeds ANSI/BIFMA and ISTA performance standards
- 

Certified SCS Indoor Advantage™
See page 13 for more details.
- 

Complies to the BIFMA e3 Sustainability Standard.
See page 13 for more details.
- 

Caution
- 

Easy to assemble
- 

Shippable by small-package carrier
- 

Wheel-chair compatible
- 

Soft-tread caster option available
- 

Readily Available. For additional lead time information see page 19.
- 

Available within a “standard” or “extended” lead time. For additional lead time information see page 19.
- 

May have extended lead times. For additional lead time information see page 19.
- 

Product shipped two to a carton
- 

Product shipped four to a carton
- 

Fire Code
- 

Core Product Line
- 

ColorCorrect® Eligible Product
- 

Product scheduled for discontinuation
- 

DE-EMPHASIZED: Product or fabric/surface material is de-emphasized, effective date as noted. Not carded. View online at honready.hon.com
- 

Warranted for multiple shift use, 24 hours a day 7 days a week

SEATING FUNCTIONS

Work/task chairs need to be adjusted to deliver optimum support. Cross-reference the letter key below to identify the chairs in this section that best meet your needs.

PROPORTIONAL ADJUSTMENTS

These controls adapt the dimensions of the chair to fit the user.



A. Pneumatic seat height adjustment — Regulates height of chair relative to floor.

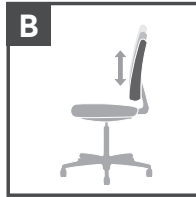

B. Back height adjustment — Positions lumbar support within a fixed range.

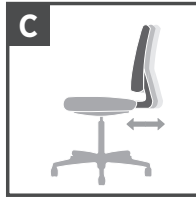

C. Seat depth adjustment — Positions chair back relative to seat.

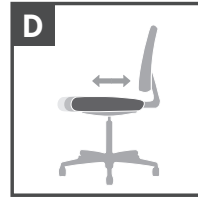

D. Seat slide mechanism — Seat cushion travels forward and back, then locks into position.

ARM OPTIONS

These adjustments accommodate different sized users and support keyboarding.



Q. Adjustable height arms — Provide improved upper-torso support. Can be adjusted periodically to relieve strain and provide variety.

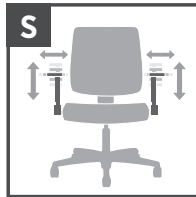

S. Height and width adjustable arms — Controls both height and width of arms for optimum comfort.



T. Loop arms — Largely specified for aesthetics. Frequently used in management settings.

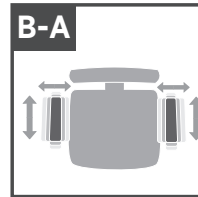

B-A. All-adjustable arms — Arms adjust in height, width, and depth.

SEATING FUNCTIONS

POSTURE CONTROLS

The controls modify the position and angle of the seat and back to respond to changing tasks.



E. 360° Swivel

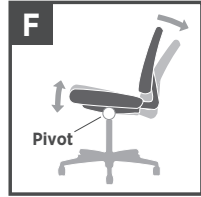

F. Tilt — Pivot point located directly above center of chair base.

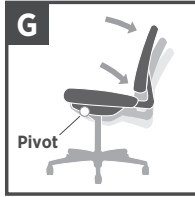

G. Mid-range knee tilt — Pivot point located slightly ahead of center of chair base. Allows user to recline at a slightly more relaxed angle than conventional tilt.

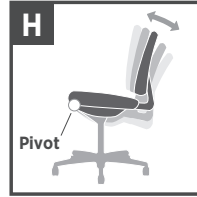

H. Knee tilt — Pivot point located near front edge of chair. Allows user to keep feet flat on floor while chair reclines.

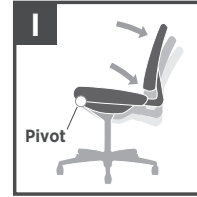

I. Synchronized knee tilt — Back reclines at a 2-to-1 ratio to seat angle. Pivot point located near front edge of chair.

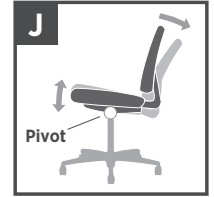

J. Synchro-tilt — Back reclines at a 2-to-1 ratio to seat angle. Allows user to recline while keeping seat cushion relatively level to floor.



K. Tilt tension — Controls rate and ease of recline.



L. Tilt lock — Locks out tilt function.



M. Posture mechanism/lock — Back angle adjusts independently of seat, and can be locked in an infinite number of positions within a fixed range.



N. Multi-task control — Adjusts seat and back angles independently with a single lever (infinite locking within a fixed range).



O. Asynchronous control — High performance system with three levers to modify: angle of back relative to seat, tilt (free float or infinite locking) and forward tilt.



W. Integral lumbar support — Easily adjusts to enhance comfort.



X. Dual-clutch posture control — Adjusts seat and back angles independently with two levers (infinite locking within a fixed range).

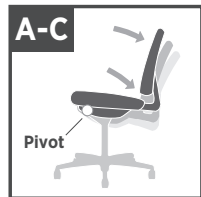

A-C. Synchronized tilt — Back reclines at a 2.5 to 1 ratio to seat angle. Variable lock.



A-D. Side tilt tension — Controls rate and ease of recline. Conveniently located on the right side.



A-E. Back reclines at a 2 to 1 ratio to seat angle. Back angle adjusts independently of seat and can be locked in infinite number of positions within a fixed range.

FABRIC PATTERNS & CODES



FABRIC PATTERNS & CODES

- For additional HON to Supply COM fabric grade pricing, go to honready.hon.com and search on the HON to Supply COM link.
- All specifications in this publication are based on the latest product information available at the time of print.
- Certain dyes (including clothing and accessory dyes such as those used on denim jeans) may migrate to lighter colors. This phenomenon is increased by humidity and temperature and is irreversible. The HON Company LLC does not assume responsibility for dye transfer caused by external contaminants.
- COM Ordering Information and pricing on page 11.
- See page 12 for Partnership Textile program information.
- All standard fabrics are carded. Cards are available through HON Literature Fulfillment.
- Remember to add an FC to the base model number when fire code fabric is selected. New Models with FC Fire Code suffix meet CA Technical Bulletin 133. See pages 26-29 for available models/fabrics.
- Fabrics and foam meet requirements for CAL-TB 117-2013.
- Fire Code fabrics with FC foam meet requirements for CA Technical Bulletin 133.

LEAD TIMES

THE FOLLOWING ICONS ARE USED TO DENOTE FABRIC OPTION LEAD TIMES

FABRIC/FINISH LEAD TIME INDICATOR



Fabric is readily available. Products using these fabrics will receive the best available product lead time and are a good option for standards programs as they will be in the HON portfolio for several years. Go to honready.hon.com and use **Compass** for product lead times by series.



Fabric is available within standard lead times. Products using these fabrics will receive a “standard” or “extended” lead time. The lead time will be determined by the combination of product and fabric. Go to honready.hon.com and use **Compass** for product lead times by series.



Fabric may have extended lead times. Products using these fabrics will typically have a 4+ week lead time. Go to honready.hon.com and use the **Compass** tool for product lead times by series.

HON EXPRESS QUICK SHIP PROGRAM

For the full list of products delivered in 5 business days or less, visit honready.hon.com.

PRODUCT LEAD TIMES

Standard lead times for products are between 2-4 weeks. For current exceptions to our standard lead time, go to honready.hon.com and use the **Compass** tool.

In order to establish accurate expectations for your project, please review this listing prior to submitting your purchase order.

Lead time calculation begins when order is free from any holds (i.e., bad lines, material, credit, etc.).

Please note, these production lead time estimates do NOT include delivery time. All published lead times are estimates, not guarantees of delivery.

For further information concerning lead times, please contact HON Customer Support via email HONTeamBox@honcompany or by phone at **800-833-3964**.

FABRIC PATTERNS & CODES

GRADE 1

APEX	APX
◆ Basalt	APX25
◆ Beet	APX12
◆ Blackberry	APX20
◆ Chive	APX05
◆ Iris	APX03
◆ Kiwi	APX06
◆ Lemonade	APX08
◆ Navy	APX13
◆ Papaya	APX09
◆ Pumice	APX23
◆ Rain	APX19
◆ Resort	APX15
◆ Royal	APX14
◆ Tiki	APX29
◆ Tomato	APX11

ATTIRE AI

◆ Blaze *	AI42
◆ Blue Lagoon *	AI90
◆ Crimson *	AI62
◆ Fatigue *	AI76
◆ Ivy *	AI82
◆ Lithium *	AI19
◆ Onyx *	AI10
◆ Sable *	AI49
◆ Taupe *	AI26
◆ Turquoise *	AI96

BLACK FABRIC ACCF

◆ Black	ACCF10
---------	--------

BLACK MESH ACCM

◆ Black	ACCM10
---------	--------

CENTURION CU

◆ Apricot	CU47
◆ Bark	CU25
◆ Black	CU10
◆ Espresso	CU49
◆ Fog	CU03
◆ Frost	CU22
◆ Goldenrod	CU27
◆ Indigo	CU06
◆ Iris	CU50
◆ Iron Ore	CU19
◆ Jade	CU83
◆ Marsala	CU63
◆ Morel	CU24
◆ Navy	CU98
◆ Peacock	CU97
◆ Pear	CU84
◆ Ruby	CU67
◆ Sapphire	CU09

GRADE 1 *continued*

COMPASS	COMP
◆ Beach	COMP16
◆ Bittersweet	COMP46
◆ Chocolate	COMP49
◆ Ink	COMP10
◆ Meadow	COMP82
◆ Midnight	COMP90
◆ Putty	COMP22
◆ Ruby	COMP62
◆ Sterling	COMP19
◆ Taupe	COMP26
◆ Tide	COMP96

COMPASS FOAM* COMF

◆ Bittersweet	COMF46
◆ Ink	COMF10
◆ Meadow	COMF82
◆ Midnight	COMF90
◆ Putty	COMF22
◆ Sterling	COMF19

**This fabric available for Solve* Upholstered Back models only.*

CONTOURETT POLYURETHANE UR

◆ Baltic	UR94
◆ Beach	UR23
◆ Black	UR10
◆ Bordeaux	UR63
◆ Buff	UR22
◆ Cloud	UR18
◆ Coffee Bean	UR49
◆ Crater	UR51
◆ Flame	UR62
◆ Graphite	UR19
◆ Iron	UR20
◆ Luggage	UR26
◆ Marine	UR92
◆ Navy	UR95
◆ Nimbus	UR93
◆ Ocean	UR96
◆ Pumpkin	UR42
◆ Quarry	UR24
◆ Red	UR64
◆ Safari	UR27
◆ Sage	UR82
◆ Steel	UR21
◆ Storm	UR17
◆ Taupe	UR28
◆ Trunk	UR50

GRADE 1 *continued*

DAPPER	DAPR
◆ Ash	DAPR20
◆ Azalea	DAPR95
◆ Breeze	DAPR06
◆ Canvas	DAPR25
◆ Currant	DAPR00
◆ Emerald	DAPR75
◆ Fawn	DAPR35
◆ Fern	DAPR85
◆ Jewel	DAPR08
◆ Marigold	DAPR65
◆ Onyx	DAPR10
◆ Orchid	DAPR90
◆ Peony	DAPR50
◆ Pool	DAPR05
◆ Rose	DAPR40
◆ Sapphire	DAPR07
◆ Scarlet	DAPR45
◆ Sepia	DAPR30
◆ Slate	DAPR15
◆ Sorbet	DAPR55
◆ Spice	DAPR60
◆ Spring	DAPR80
◆ Varsity	DAPR09
◆ Zest	DAPR70

ENSEMBLE ENSB

◆ Aquamarine	ENSB30
◆ Ash	ENSB39
◆ Greige	ENSB36
◆ Harbor	ENSB34
◆ Navy	ENSB35
◆ Oat	ENSB37
◆ Pear	ENSB33
◆ Sand	ENSB38
◆ Scarlet	ENSB32
◆ Slate	ENSB31
◆ Stone	ENSB40

GRADE 1 *continued*

HAMILTON	HAML
◆ Azure	HAML10
◆ Biscotti	HAML11
◆ Cabernet	HAML08
◆ Carolina	HAML21
◆ Charcoal	HAML17
◆ Chocolate	HAML13
◆ Cloud	HAML18
◆ Dane	HAML16
◆ Dusty Rose	HAML07
◆ Esmeralda	HAML06
◆ Fern	HAML04
◆ Fresh	HAML03
◆ Granola	HAML19
◆ Lilac	HAML14
◆ Lime	HAML05
◆ Lipstick	HAML09
◆ Oxford	HAML20
◆ Passion Fruit	HAML02
◆ Pepper	HAML15
◆ Powder	HAML12
◆ Sunrise	HAML01

INERTIA NR

◆ Amethyst	NR61
◆ Calypso	NR98
◆ Cherry	NR66
◆ Cobalt	NR91
◆ Coffee	NR49
◆ Fog	NR19
◆ Fuchsia	NR63
◆ Gecko	NR76
◆ Glow	NR27
◆ Leaf	NR75
◆ Lime	NR82
◆ Loft	NR22
◆ Mandarin	NR47
◆ Meteor	NR30
◆ Mustard	NR26
◆ Nickel	NR23
◆ Onyx	NR10
◆ Regatta	NR90
◆ Shadow	NR20
◆ Surf	NR96
◆ Tangelo	NR46

OPTIC OP

◆ Aurora	OP72
◆ Bark	OP24
◆ Canopy	OP84
◆ Char	OP49
◆ Ruby	OP42
◆ Sand	OP17
◆ Sky	OP83
◆ Slate	OP19
◆ Sprout	OP74
◆ Starry Night	OP11
◆ Storm	OP56
◆ Wildfire	OP66

* Fabric is de-emphasized.

FABRIC PATTERNS & CODES

GRADE 2

APPOINT SEATING	PNS
◆ Blackberry	PNS012
◆ Bronze	PNS002
◆ Carbon	PNS008
◆ Cherry	PNS010
◆ Espresso	PNS003
◆ Framboise	PNS011
◆ Jet	PNS007
◆ Lawn	PNS005
◆ Mandarin	PNS009
◆ Morel	PNS001
◆ Platinum	PNS004
◆ Turquoise	PNS006

BLUME	BLME
◆ Chalk	BLME03
◆ Char	BLME00
◆ Coin	BLME02
◆ Driftwood	BLME05
◆ Emerald City	BLME07
◆ Fir	BLME09
◆ Harvest	BLME04
◆ Haze	BLME08
◆ Hyacinth	BLME14
◆ Jasper	BLME13
◆ Merlot	BLME10
◆ Moonstone	BLME01
◆ Opal	BLME06
◆ Scarlet	BLME11
◆ Slate	BLME12

CLYDE	CLYD
◆ Antique	CLYD04
◆ Artifact	CLYD01
◆ Blacksmith	CLYD10
◆ Claret	CLYD13
◆ Craftsman	CLYD08
◆ Crate	CLYD12
◆ Fossil	CLYD02
◆ Heirloom	CLYD05
◆ Iron	CLYD11
◆ Linen	CLYD14
◆ Relic	CLYD06
◆ Seasoned	CLYD03
◆ Trestle	CLYD07
◆ Weathered	CLYD09

GRADE 2 *continued*

DOTTY	DOT
◆ Candy	DOT63
◆ Gelato	DOT34
◆ Indigo	DOT31
◆ Onyx	DOT35
◆ Park	DOT83
◆ Peat	DOT24
◆ Peony	DOT32
◆ Suit	DOT20
◆ Sunflower	DOT33
◆ Tailor	DOT21
◆ Tide	DOT90
◆ Velum	DOT29
◆ Violet	DOT30

RUSH	RUSH
◆ Anchor	RUSH07
◆ Basil	RUSH16
◆ Blueberry	RUSH10
◆ Flamingo	RUSH21
◆ Greenery	RUSH15
◆ Greyhound	RUSH06
◆ Marina	RUSH13
◆ Merlot	RUSH19
◆ Midnight	RUSH11
◆ Mint	RUSH09
◆ Mulberry	RUSH18
◆ Pumice	RUSH01
◆ Punch	RUSH20
◆ Sage	RUSH14
◆ Salsa	RUSH24
◆ Sand	RUSH05
◆ Seal	RUSH08
◆ Soot	RUSH02
◆ Stout	RUSH03
◆ Sunshine	RUSH23
◆ Tapestry	RUSH04
◆ Tiger	RUSH22
◆ Vintage	RUSH17
◆ Wave	RUSH12

SEED	SED
◆ Apple	SED11
◆ Ash	SED15
◆ Cardinal	SED09
◆ Cinder	SED17
◆ Cream	SED12
◆ Driftwood	SED13
◆ Harbor	SED10
◆ Onyx	SED18
◆ Smoke	SED16
◆ Truffle	SED14

GRADE 2 *continued*

SPIN SEATING	SPNN
◆ Alabaster	SPNN02
◆ Cavern	SPNN03
◆ Cobblestone	SPNN04
◆ Ember	SPNN06
◆ Flame	SPNN07
◆ Heron	SPNN13
◆ Oat	SPNN01
◆ Ocean	SPNN12
◆ Plum	SPNN15
◆ Pool	SPNN11
◆ Raven	SPNN10
◆ Rhubarb	SPNN14
◆ Tropic	SPNN08
◆ Willow	SPNN05

WHISPER VINYL	WP
◆ Antelope	WP20
◆ Black	WP40
◆ Bone	WP17
◆ Bordeaux	WP26
◆ Brick Red	WP99
◆ Camel	WP18
◆ Cappuccino	WP21
◆ Carotene	WP97
◆ Cashew	WP29
◆ Cerulean	WP36
◆ Charcoal	WP39
◆ Cinnamon	WP25
◆ Cognac	WP62
◆ Cucumber	WP88
◆ Elephant	WP38
◆ Espresso	WP49
◆ Fawn	WP91
◆ Fog	WP100
◆ Forest	WP82
◆ Gravel	WP19
◆ Indigo	WP86
◆ Luggage	WP23
◆ Mahogany	WP93
◆ Mallard	WP90
◆ Merlot	WP27
◆ Molten	WP98
◆ Navy	WP37
◆ Ochre	WP96
◆ Paradise	WP85
◆ Patina	WP34
◆ Pewter	WP83
◆ Putty	WP84
◆ Salsa	WP42
◆ Sangre	WP28
◆ Sassafras	WP89
◆ Storm	WP92
◆ Truffle	WP95
◆ Zest	WP87

GRADE 3

IN SEASON	ISN
◆ Black	ISN001
◆ Blue Jay	ISN007
◆ Fire	ISN004
◆ Jungle	ISN008
◆ Lake	ISN006
◆ Lead	ISN002
◆ Limestone	ISN041
◆ Ocean	ISN005
◆ Silver	ISN003
◆ Smoke	ISN020
◆ Tundra	ISN011

PURL	PURL
◆ Alpaca	PURL08
◆ Braid	PURL10
◆ Deep	PURL12
◆ Graze	PURL05
◆ Loom	PURL06
◆ Needle	PURL07
◆ Pasture	PURL02
◆ Ranch	PURL04
◆ Shuttle	PURL09
◆ Skein	PURL01
◆ Thistle	PURL11
◆ Yearling	PURL03

QUILL	QUL
◆ Aviary	QUL03
◆ Feather	QUL02
◆ Fountain	QUL06
◆ Ink	QUL05
◆ Metal	QUL04
◆ Reed	QUL08
◆ Scroll	QUL01
◆ Well	QUL07

FABRIC PATTERNS & CODES

GRADE 3

continued

SILVERTEX™ VINYL	SX
◆ Acid	SX34
◆ Basil	SX20
◆ Bazaar	SX37
◆ Blackberry	SX17
◆ Borscht	SX15
◆ Bottle	SX21
◆ Bronze	SX32
◆ Carbon	SX23
◆ Celery	SX19
◆ Champagne	SX08
◆ Chestnut	SX10
◆ Cream	SX07
◆ Crème de Menthe	SX33
◆ Ice	SX06
◆ Imperial	SX38
◆ Jet	SX05
◆ Lagoon	SX02
◆ Limoncello	SX42
◆ Luggage	SX13
◆ Mandarin	SX11
◆ Marine Blue	SX01
◆ Marsh	SX31
◆ Meteor	SX24
◆ Mocha	SX25
◆ Neutra	SX30
◆ Peat	SX35
◆ Plata	SX39
◆ Poppy	SX12
◆ Raspberry	SX16
◆ Sage	SX18
◆ Sapphire	SX04
◆ Sterling	SX40
◆ Storm	SX22
◆ Taupe	SX09
◆ Turquoise	SX03
◆ Umber	SX14
◆ Zest	SX41

GRADE L1

DENVER LEATHER	SS
◆ Black	SS11

For a complete list of fabrics, including partnership fabrics, go to hon.com/fabricsandfinishes.

ORDERING INFORMATION

Steel Seating	Standard Fabric Selections by Series with Price Code and Fabric Material																								
	1	1	1	1	1	1	1	1	1	1	1	1	1	1	2	2	2	2	2	2	3	3	3	L	
Model/Series	AI	EB	VA	GA	MM	EA	CU	COMP	COMF	UR	DAPR	HAML	NR	OP	PNS	CLYD	DOT	RUSH	SED	SPNN	WP	ISN	PURL	SX	SS
	Attire	Black & Burgundy Vinyl	Black, Charcoal, Burgundy, & Navy Fabric	Black, Crimson, & Navy Fabric	Black Sandwich Mesh Fabric	Black Vinyl	Centurion	Compass	Compass Foam	Contourett Polyurethane	Dapper	Hamilton	Inertia	Optic	Appoint Seating	Clyde	Doty	Rush	Seed	Spit Seating	Whisper Vinyl	In Season	Purl	Silvertex™ Vinyl	Denver Leather***
Accommodate®	•						•	•		•	•	•	•	•	•	•	•	•	•	•	•	•	•	•	•
Adjustable Task/Lab Stool						•																			
Boda™					•																				
Ceres® Series	•						•	•		•	•	•	•	•	•	•	•	•	•	•	•	•	•	•	•
ComforTask® 5900 Series	•							•	•		•	•	•	•	•	•	•	•	•	•	•	•	•	•	•
Convergence®	•						•	•		•	•	•	•	•	•	•	•	•	•	•	•	•	•	•	•
Endorse® Task	•						•	•		•	•	•	•	•	•	•	•	•	•	•	•	•	•	•	• (Seat Only)
Flock**	•						•	•		•	•	•	•	•	•	•	•	•	•	•	•	•	•	•	•
Flock® Round Lounge HFLRC1/DF and Stool HFSS7							•	•		•	•	•	•	•	•	•	•	•	•	•	•	•	•	•	•
Grove®							•	•		•	•	•	•	•	•	•	•	•	•	•	•	•	•	•	•
Ignition® Series	•						•	•		•	•	•	•	•	•	•	•	•	•	•	•	•	•	•	•
Invitation® Lounge Series	•						•	•		•	•	•	•	•	•	•	•	•	•	•	•	•	•	•	•
Lota® H2281 / H2283 / H2285			•																						
Lota® H2282 / H2284	•						•	•		•	•	•	•	•	•	•	•	•	•	•	•	•	•	•	•
Motivate®	•						•	•		•	•	•	•	•	•	•	•	•	•	•	•	•	•	•	•
Nucleus® Series	•						•	•		•	•	•	•	•	•	•	•	•	•	•	•	•	•	•	•
Pagoda® 4070/4090 Series**	•						•	•		•	•	•	•	•	•	•	•	•	•	•	•	•	•	•	•
Park Avenue Collection® 5020 Series	•						•	•		•	•	•	•	•	•	•	•	•	•	•	•	•	•	•	•
Perpetual® Nesting	•						•	•		•	•	•	•	•	•	•	•	•	•	•	•	•	•	•	•
Pillow-Soft® 2090 Series		•					•	•		•	•	•	•	•	•	•	•	•	•	•	•	•	•	•	•
Quotient®	•						•	•		•	•	•	•	•	•	•	•	•	•	•	•	•	•	•	•
Solutions Seating® 4000 Series	•						•	•		•	•	•	•	•	•	•	•	•	•	•	•	•	•	•	•
Solve®	•						•	•	•	•	•	•	•	•	•	•	•	•	•	•	•	•	•	•	• (Seat Only)
Soothe®	•						•	•		•	•	•	•	•	•	•	•	•	•	•	•	•	•	•	•
Soothe® High-Back										•	•	•	•	•	•	•	•	•	•	•	•	•	•	•	•
Volt® 5700/5710 Series				•																					
Volt® 5720/5730 Series	•						•	•		•	•	•	•	•	•	•	•	•	•	•	•	•	•	•	•
Credenza/Pedestal Cushions	•						•	•		•	•	•	•	•	•	•	•	•	•	•	•	•	•	•	•

*Flock® chair model HFLRC1 has fabric limitations, please see the Flock® seating pages 83-92 for details.

**Pagoda® wood back models available in Harvest (C), Natural Maple (D), Shaker Cherry (F), Bourbon Cherry (H) and Mahogany (N) only.

***Denver Leather (SS) may not be available on every model within a specific series, please refer to the model's page for details.

ORDERING INFORMATION

- Seating pages are now arranged in alpha, then numeric, order.
- **All specifications in this publication are based on the latest product information available at the time of print.**
- COM Ordering Information and pricing on page 11.
- Remember to add an FC to the base model number when fire code fabric is selected. New Models with FC Fire Code suffix meet CA Technical Bulletin 133. See pages 26-29 for available models/fabrics.
- Wood components are well-seasoned select hardwoods, chosen for their strength, their ability to machine well and their superior uniformity of stain and finish.
- Chairs with leather feature matching vinyl backs and vinyl seat bottom when applicable (Non-contact areas are vinyl).

FIRE CODE (CAL133)

Refer to CAL133 Compliant Seating matrices on pages 26-29 for a list of compliant models and fabrics. Add FC to the base model number.

Examples:

STANDARD: H2111.N.CU10

FIRE CODE: H2111FC.N.CU10

Wood Seating	Finish Codes								Standard Fabric Selections by Series with Price Code and Fabric Material																			
	Bourbon Cherry	Cognac	Harvest	Mahogany	Mocha	Natural Maple	Pinnacle	Shaker Cherry	1 AI	1 EB	1 CU	1 COMP	1 DAPR	1 HAML	1 NR	1 OP	2 PNS	2 CLYD	2 DOT	2 RUSH	2 SED	2 SPNN	2 WP	3 ISN	3 PURL	3 SX	L SS	
Cambia™ 2160 Series	H	COGN	C	N	MOCH	D	PINC	F	•	•	•	•	•	•	•	•	•	•	•	•	•	•	•	•	•	•	•	•
Invitation® 2110 Series	H	COGN	C	N	MOCH	D	PINC	F	•	•	•	•	•	•	•	•	•	•	•	•	•	•	•	•	•	•	•	•
Park Avenue Collection® 5000 Series	H	COGN	C	N	MOCH	D	PINC	F	•	•	•	•	•	•	•	•	•	•	•	•	•	•	•	•	•	•	•	•
Pillow-Soft® 2190 Series	H	COGN	C	N	MOCH	D	PINC	F	•	•	•	•	•	•	•	•	•	•	•	•	•	•	•	•	•	•	•	•
Versant® Tandem Wood	H	COGN	C	N	MOCH	D	PINC	F	•	•	•	•	•	•	•	•	•	•	•	•	•	•	•	•	•	•	•	•

Note: Gathers and creases may be more visible with AI and OP fabrics due to the inherent design and construction of these fabrics.

ORDERING INFORMATION

VENEERS FOR 2110 SERIES – INVITATION® TABLES AND TABLE CONNECTORS	CODES
Bourbon Cherry	H
Cognac	COGN
Mahogany	N
Mocha	MOCH
Pinnacle	PINC
Shaker Cherry	F

LAMINATES FOR VERSANT® TANDEM FREESTANDING TABLES	CODES
Bourbon Cherry	H
Cognac	COGN
Mahogany	N
Mocha	MOCH
Pinnacle	PINC
Shaker Cherry	F

FIRE CODE/COMPLIANT SEATING

FIRE SAFETY WITHOUT COMPROMISE

Elevate Fire Safety to a Higher Standard

- You asked for more seating choices that meet the CAL 133 standard. Here they are. Many of The HON Company's most popular chair models are now available in an array of fabrics that include an advanced barrier of fire protection. This barrier helps HON chairs comply with CAL 133 (California Technical Bulletin 133), the industry's most stringent test for fire-retardant furniture.

Definitive Protection

- The resilient filling materials used in upholstered seating manufactured by The HON Company meet or exceed the flame retardant requirements of the State of California, Department of Consumer Affairs, Bureau of Electronic and Home Appliance Repair, Home Furnishings and Thermal Insulation Technical Bulletin 117-2013. The label attached to the seat bottom indicates compliance with these requirements.
- For public buildings with at least 10 chairs in use, CAL 133 sets the bar as the accepted standard of fire safety. The CAL-TB 117-2013 standard referenced above evaluates the fire resistance of fabric, but only CAL 133 tests the entire assembled chair. Result: Greater assurance that your seating will not accelerate an actual fire.

How to Order

- To ensure that the chairs you order comply with CAL 133, specify one of the fabrics listed here on any of the seating models from the pages that follow. Then simply add "FC" to the model number when ordering.

SPECIFYING EXAMPLE: HSGS6FC.N.E.CU10.BLCK.

A standard upcharge of \$90 will be applied per seat model for all single seat chairs.

For Lounge Seating, the following upcharges will apply: (Please note, the lounge upcharges do not apply to the Ignition® or Versant® seating lines. For these models, the \$90 per seat applies.)

Single Seat/Club Lounge: \$250 list

2-Seat/Love Seat Lounge: \$325 list

3-Seat/Sofa: \$400 list

MOISTURE BARRIER

- This extra layer of protection prevents moisture from penetrating the foam to improve cleanability and extend product longevity. Moisture barrier is available as an option for the seat only. The recliner gets moisture barrier on seat and footrest.
- Moisture barrier is not available for the fire code models.**

How to Order

- Fire Code:** To ensure that the chairs you order comply with CAL 133, specify one of the fabrics listed here on any of the seating models from the pages that follow. Then simply add "FC" to the model number when ordering.

SPECIFYING EXAMPLE: HHCG11FC.S.AI90.PR8.

- Moisture Barrier:** When specifying Moisture Barrier simply add "MB" to the model number when ordering.

SPECIFYING EXAMPLE: HHCG11MB.S.AI90.P6N.PR8.

Upcharges for Fire Code and Moisture Barrier on Soothe® models

Model	Fire Code	Moisture Barrier
HHCG11	\$90	\$80
HHCG50	\$90	\$120
HHCG21	\$180	\$160
HHCGB21	\$180	\$160
HHCGB31	\$270	\$240
HHCP1	\$90	\$80

FIRE CODE/COMPLIANT SEATING

CAL 133 COMPLIANT FABRIC

GRADE 1

AI	Attire
APX	Apex
COMP	Compass
CU	Centurion
DAPR	Dapper
ENSB	Ensemble
HAML	Hamilton
NR	Inertia
OP	Optic

GRADE 2

BLME	Blume
CLYD	Clyde
DOT	Dotty
PNS	Appoint Seating
RUSH	Rush
SED	Seed
SPNN	Spin
WP	Whisper Vinyl

GRADE 3

ISN	In Season
PURL	Purl
QUL	Quill
SX	Silvertex™ Vinyl

GRADE L

SS	Leather
-----------	---------

Motivate®, Olson® and GuestStacker® shell chairs available in CAL 133 compliant color options as of June 2014. Please see matrix below.

SHELL COLOR	MOTIVATE®	OLSON® H4041	GUESTSTACKER® H4031
Onyx (ON)	X*	X	X
Lava (LA)		X	X
Regatta (RE)		X	X
Mulberry (MB)		X	X
Shadow (SD)		X	
Platinum (PT)		X	
Lime (LM)		X	
Tangelo (RG)		X	
Surf (BU)		X	
Calypso (CP)		X	
Loft (LO)		X	
Cherry (CR)		X	
White (WT)		X	

Creases and gathers may be visible with CAL 133 Fire Code seating due to the construction of the fire barrier material used.

*CA Technical Bulletin 133 Compliant available on Motivate® only in Onyx as a Standard Special. Contact HON Tailored Solutions Team for availability.

FIRE CODE/COMPLIANT SEATING

To ensure that the chairs you order comply with CAL 133, choose one of these seating fabrics with the seating models listed here. Then simply add "FC" to the model number when ordering as shown here: **HIWM2FC.A.H.M.CU10.T.SB. A standard upcharge of \$90 will be applied per seat. Example, HMG2 has 2 seats @ \$90 per seat, \$180 upcharge.**

CAL 133 Compliant Seating

ALL MODELS INCLUDED IN THIS PROGRAM ARE LISTED BELOW.

Fabric Grade	1	1	1	1	1	2	2	2	3	L
Series/Model Numbers	Attire	Centurion	Compass	Inertia	Optic	Appoint	Dotty	Whisper Vinyl	Silvertex Vinyl	Leather*
	AI	CU	COMP	NR	OP	PNS	DOT	WP	SX	SS/SR
Accommodate*										
HSGS6FC, HSGS6DFFC, HSCS1FC	•	•	•	•	•	•	•	•	•	
HSCS1DFFC, HSCS2FC, HSCS2DFFC	•	•	•	•	•	•	•	•	•	
HSB50FC, HSB50DFFC	•	•	•	•	•	•	•	•	•	
Cambia™										
H2164FC, H2165FC	•	•	•	•	•	•	•	•	•	•
Ceres*										
HCW1FC, HCG6FC	•	•	•	•	•	•	•	•	•	•
ComforTask*										
H5901FC, H5902FC, H5903FC	•	•	•	•	•	•	•	•	•	
H5905FC	•	•	•	•	•	•	•	•	•	
Endorse*										
HLWMFC	•	•	•	•	•	•	•	•	•	•
HLWMBTFC, HLTSMFC, HLTMFC	•	•	•	•	•	•	•	•	•	
HLWUFC, HLTUFC, HLEUFC	•	•	•	•	•	•	•			
HLWUBTFC, HLEUBTFC, HLTSUFC	•	•	•	•	•	•	•			
Flock* Seating										
HFLSC1FC, HFLMC1FC, HFLML1FC	•	•	•	•	•	•	•			•
HFLMR1FC, HFLSO1FC	•	•	•	•	•	•	•			•
HFLRC1FC		•	•	•	•	•		•	•	•
Grove*										
HML1SFC, HML1SDFFC, HML2SFC		•	•	•	•	•	•			•
HML2SDFFC, HML3SFC, HML3SDFFC		•	•	•	•	•	•			•
HML2STFC, HML2STDFFC		•	•	•	•	•	•			•
Ignition* Seating										
HIEH1FC, HIEH2FC, HIEH3FC	•	•	•	•	•	•	•	•	•	•
HIWM1FC, HIWM2FC, HIWM3FC	•	•	•	•	•	•	•	•	•	•
HIWM8FC, HITL1FC, HITL2FC	•	•	•	•	•	•	•	•	•	•
HITL3FC, HITS5FC, HIGCLFC	•	•	•	•	•	•	•	•	•	•
HIGS6FC, HISB6FC, HICS7FC	•	•	•	•	•	•	•	•	•	•
HIB50FC, HITLMFC, HIWMMFC	•	•	•	•	•	•	•	•	•	•
HITSMFC	•	•	•	•	•	•	•	•	•	•
Invitation*										
H2111FC, H2112FC	•	•		•	•	•	•	•	•	
Invitation* Lounge										
HFAA01FC, HFAL02FC, HFAS03FC	•	•	•	•	•	•	•			•

*Denver Leather (SS) may not be available on every model within a specific series, please refer to the model's page for details.

FIRE CODE/COMPLIANT SEATING

To ensure that the chairs you order comply with CAL 133, choose one of these seating fabrics with the seating models listed here. Then simply add “FC” to the model number when ordering as shown here: **HIWM2FC.A.H.M.CU10.T.SB. A standard upcharge of \$90 will be applied per seat. Example, HMG2 has 2 seats @ \$90 per seat, \$180 upcharge.**

CAL 133 Compliant Seating

ALL MODELS INCLUDED IN THIS PROGRAM ARE LISTED BELOW.

Fabric Grade	1	1	1	1	1	2	2	2	3	L
Series/Model Numbers	Attire	Centurion	Compass	Inertia	Optic	Appoint	Dotty	Whisper Vinyl	Silvertex Vinyl	Leather*
	AI	CU	COMP	NR	OP	PNS	DOT	WP	SX	SS/SR
Nucleus® Seating										
HN1FC, HN6FC, HN7FC	•	•	•	•	•	•	•	•	•	•
Pagoda®										
H4071FC, H4073FC, H4075FC	•	•	•	•	•	•	•	•	•	
H4077FC, H4079FC, H4091FC	•	•	•	•	•	•	•	•	•	
H4093FC, H4095FC, H4097FC	•	•	•	•	•	•	•	•	•	
H4099FC	•	•	•	•	•	•	•	•	•	
Park Avenue Collection®										
H5001FC, H5002FC		•	•	•	•	•				•
H5021FC, H5022FC		•	•	•	•	•				•
H5023FC		•	•	•	•	•	•	•	•	•
Perpetual® Nesting Chairs										
HPN1FC, HPN2FC	•	•	•	•	•	•	•	•	•	
Pillow-Soft®										
H2091FC, H2092FC, H2191FC		•	•	•	•	•				•
H2192FC		•	•	•	•	•				•
H2093FC, H2194FC		•	•	•	•	•	•	•	•	•
Quotient®										
HQTM1FC, HQTM2FC	•	•	•	•	•	•	•	•	•	
Solutions Seating®										
H4001FC, H4002FC	•	•	•	•	•	•				
H4003FC, H4008FC	•	•	•	•	•	•	•	•	•	
Solve®										
HSLV1FC, HSLV2FC	•	•	•	•	•	•	•	•	•	•
HSLV3FC, HSLV4FC	•	•	•	•	•	•	•	•	•	•
Soothe®										
HHCG11FC, HHCG50FC, HHCG21FC	•	•	•	•	•		•	•	•	•
HHCGB21FC, HHCGB31FC	•	•	•	•	•		•	•	•	•
HHCP1FC									•	
Versant®										
HHCT01FC, HHCT12FC, HHCT02FC	•	•	•	•	•	•	•	•	•	•
HHCB50FC, HHB02FC, HHB03FC	•	•	•	•	•	•	•	•	•	•

*Denver Leather (SS) may not be available on every model within a specific series, please refer to the model's page for details.

ACCOMMODATE®



Accommodate® Café-Height Stools shown in Centurion Black.

ACCOMMODATE®

The key to designing a collaborative environment is to support productivity throughout the space. From waiting areas and cafés to meeting spaces and offices, Accommodate creates opportunities for people to get work done in a comfortable, casual setting. Cluster together. Form neat rows. Stack four high. With guest and bariatric chairs, as well as café and counter-height stools, Accommodate brings greater comfort, versatility and continuity throughout your space with a seating collection that adapts to your environment, people and budget.



FEATURES

- Thin profile seat cushion conforms to your body.
- Contoured back ergonomically supports the spine.
- Chairs can stack up to four high.
- Chairs can gang together to form neat rows.
- Waterfall seat edge enhances leg circulation.
- Lightweight frame is easy to move.
- Nylon glides slide effortlessly on hard surfaces.
- Tube rolled steel frame adds durability.
- Wall-saver design protects walls and cabinets.
- Warranted for users up to 300 lbs. (Models HSB50 and HSB50DF are warranted for users up to 500 lbs.)

MODEL OPTIONS

HSGS6
HSGS6DF - Dual Fabric



Guest Chair

HSCS1
HSCS1DF - Dual Fabric



Counter-Height Stool

HSCS2
HSCS2DF - Dual Fabric



Café-Height Stool

HSB50
HSB50DF - Dual Fabric

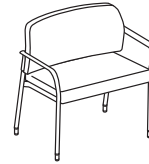

Bariatric Chair

ARM STYLE

CODE	DESCRIPTION	PRICE
N	Armless	+\$0
F	Fixed Arms	+\$30



FRAME

CODE	DESCRIPTION	PRICE
BLCK	Textured Black	+\$0
PK7	Textured Designer White	+\$0
P7J	Textured Brownstone	+\$0
P7A	Textured Charcoal	+\$0
P7L	Textured Loft	+\$0
P7M	Textured Muslin	+\$0
PR8	Textured Silver	+\$0
P8V	Textured Titanium	+\$0



CASTERS/ GLIDES

CODE	DESCRIPTION	PRICE
E	Standard Nylon Glide	+\$0
H	Hard Caster	+\$0
S	Soft Caster	+\$20
B	Both Hard Casters and Standard Nylon Glides	+\$20



*Options H, S & B available for HSGS6 and HSGS6DF models only

ACCOMMODATE®

Fabric Options

HON BRANDED FABRICS

GRADE 1

Apex
Attire
Centurion
Compass
Contourett
Dapper
Ensemble
Hamilton
Inertia
Optic

GRADE 2

Appoint Seating
Blume
Clyde
Dotty
Rush
Seed
Spin
Whisper Vinyl

GRADE 3

In Season
Purl
Quill
Silvertex™ Vinyl

For a complete list of fabrics, including partnership fabrics, go to hon.com/fabricsandfinishes.

Reference Fabric Color Combinations on pages 18-22 for color codes and legend on page 19 for lead times.

 For Fire Code model, availability and ordering method, refer to pages 26-29. Available on select models, contact HON Customer Support for availability.



HSGS6

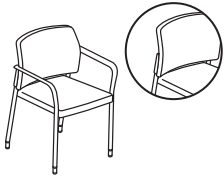

GUEST CHAIR

Set of Two Guest Chairs

DIMENSIONS

Depth:	22¼	Seat to Floor Height:	18¼
Height:	31½	Usable Seat Depth:	17
Seat Depth:	20¾	Ship Weight (with arms):	50
Seat Width:	17½	Ship Weight (armless):	48
Back Width:	19¾	Cube (with arms):	15.8
Back Height:	16¼	Cube (armless):	15.8
Width (with arms):	23½	COM (per 2 pack):	3.0
Width (armless):	19¾	Weight Rating:	300 lbs.
Arm Width:	20¼		

FABRIC PRICE CODES

1	\$754	8	\$1168
2	\$826	9	\$1222
3	\$898	10	\$1276
4	\$952	11	\$1330
5	\$1006	12	\$1384
6	\$1060	L	—
7	\$1114		

HSCS1

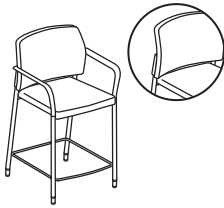

COUNTER-HEIGHT STOOL

DIMENSIONS

Depth:	23½	Seat to Floor Height:	25½
Height:	38¾	Usable Seat Depth:	17
Seat Depth:	20¾	Ship Weight (with arms):	36
Seat Width:	17½	Ship Weight (armless):	35
Back Width:	19¾	Cube (with arms):	15.8
Back Height:	16¼	Cube (armless):	15.8
Width (with arms):	23½	COM:	2.0
Width (armless):	19¾	Weight Rating:	300 lbs.
Arm Width:	20¼		

FABRIC PRICE CODES

1	\$458	8	\$665
2	\$494	9	\$692
3	\$530	10	\$719
4	\$557	11	\$746
5	\$584	12	\$773
6	\$611	L	—
7	\$638		

HSGANG

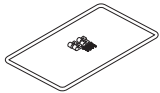

GANGING BRACKET

(hardware included)

DIMENSIONS

Ship Weight: 5 Ⓢ

LIST PRICE

\$34

NOTES: For use on models HSGS6 and HSGS6DF.

! No specification required for bracket. The ganging bracket is only available in black. The ganging bracket does not work on the bariatric unit.

HON Recommendation: HSGS6.N.E.CU__PR8 - List Price \$754

HOW TO SPECIFY

<p>Select Model Number</p> <p>H S G S 6 .</p>	<p>Select Arm Type</p> <p>N Armless F Fixed Arms (+ \$30 per chair)</p> <p>N .</p>	<p>Select Caster/Glide</p> <p>E Standard Nylon Glide H Hard Caster S Soft Caster (+ \$20 per chair) B Both Hard Casters and Standard Nylon Glides (+ \$20 per chair)</p> <p><i>Options H, S & B available for HSGS6 model only</i></p> <p>E .</p>	<p>Select Fabric</p> <p>See page 32</p> <p>C U 1 0 .</p>	<p>Select Frame</p> <p>See page 31</p> <p>P R 8</p>
--	---	--	---	--

ACCOMMODATE®

GSA SIN 33721



Icon Legend on page 15

HSCS2

CAFÉ-HEIGHT STOOL



DIMENSIONS

Depth:	24½	Seat to Floor Height:	31½
Height:	44¾	Usable Seat Depth:	17
Seat Depth:	20¾	Ship Weight (with arms):	38
Seat Width:	17½	Ship Weight (armless):	37
Back Width:	19¾	Cube (with arms):	19.1
Back Height:	16¼	Cube (armless):	19.1
Width (with arms):	23½	COM:	2.0
Width (armless):	19¾	Weight Rating:	300 lbs.
Arm Width:	20¼		

FABRIC PRICE CODES

1	\$502	8	\$709
2	\$538	9	\$736
3	\$574	10	\$763
4	\$601	11	\$790
5	\$628	12	\$817
6	\$655	L	—
7	\$682		

HSB50

BARIATRIC CHAIR

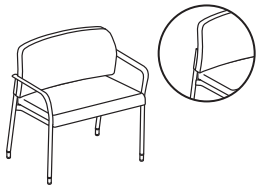

DIMENSIONS

Depth:	21½	Seat to Floor Height:	19
Height:	32½	Usable Seat Depth:	16¾
Seat Depth:	20¼	Ship Weight (with arms):	50
Seat Width:	28	Ship Weight (armless):	49
Back Width:	29	Cube (with arms):	27.2
Back Height:	16½	Cube (armless):	27.2
Width (with arms):	33½	COM:	2.0
Width (armless):	30	Weight Rating:	500 lbs.
Arm Width:	30		

FABRIC PRICE CODES

1	\$809	8	\$1085
2	\$857	9	\$1121
3	\$905	10	\$1157
4	\$941	11	\$1193
5	\$977	12	\$1229
6	\$1013	L	—
7	\$1049		

HON Recommendation: HSCS2.N.E.CU__PR8 - List Price \$502

HOW TO SPECIFY

Select Model Number <div style="border: 1px solid black; display: inline-block; padding: 2px;">H</div> <div style="border: 1px solid black; display: inline-block; padding: 2px;">S</div> <div style="border: 1px solid black; display: inline-block; padding: 2px;">C</div> <div style="border: 1px solid black; display: inline-block; padding: 2px;">S</div> <div style="border: 1px solid black; display: inline-block; padding: 2px;">2</div>	Select Arm Type N Armless F Fixed Arms (+ \$30 per chair)	Select Caster/Glide E Standard Nylon Glide	Select Fabric See page 32	Select Frame See page 31
<div style="border: 1px solid black; display: inline-block; padding: 2px;">H</div> <div style="border: 1px solid black; display: inline-block; padding: 2px;">S</div> <div style="border: 1px solid black; display: inline-block; padding: 2px;">C</div> <div style="border: 1px solid black; display: inline-block; padding: 2px;">S</div> <div style="border: 1px solid black; display: inline-block; padding: 2px;">2</div>	<div style="border: 1px solid black; display: inline-block; padding: 2px;">N</div>	<div style="border: 1px solid black; display: inline-block; padding: 2px;">E</div>	<div style="border: 1px solid black; display: inline-block; padding: 2px;">C</div> <div style="border: 1px solid black; display: inline-block; padding: 2px;">U</div> <div style="border: 1px solid black; display: inline-block; padding: 2px;">1</div> <div style="border: 1px solid black; display: inline-block; padding: 2px;">0</div>	<div style="border: 1px solid black; display: inline-block; padding: 2px;">P</div> <div style="border: 1px solid black; display: inline-block; padding: 2px;">R</div> <div style="border: 1px solid black; display: inline-block; padding: 2px;">8</div>



HSGS6DF

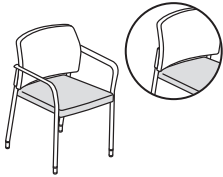

GUEST CHAIR

Dual Fabric
Set of Two Guest Chairs

DIMENSIONS

Depth:	22¼	Seat to Floor Height:	18¼
Height:	31½	Usable Seat Depth:	17
Seat Depth:	20¾	Ship Weight (with arms):	50
Seat Width:	17½	Ship Weight (armless):	48
Back Width:	19¾	Cube (with arms):	15.8
Back Height:	16¼	Cube (armless):	15.8
Width (with arms):	23½	COM (Seat, per 2 pack):	1.5
Width (armless):	19¾	COM (Back, per 2 pack):	1.5
Arm Width:	20¼	Weight Rating:	300 lbs.

FABRIC PRICE CODES

1	\$910	
<i>Add to Base Price Above</i>		
	Back	Seat
2	\$36	\$36
3	\$72	\$72
4	\$99	\$99
5	\$126	\$126
6	\$153	\$153
7	\$180	\$180
8	\$207	\$207
9	\$234	\$234
10	\$261	\$261
11	\$288	\$288
12	\$315	\$315

NOTES: For Ganging Brackets see page 36. Accommodate® Guest Chairs stack 4-high.

HSCS1DF

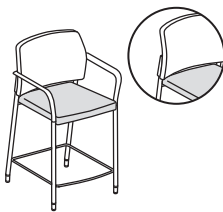

COUNTER-HEIGHT STOOL

Dual Fabric

DIMENSIONS

Depth:	23½	Seat to Floor Height:	25½
Height:	38¾	Usable Seat Depth:	17
Seat Depth:	20¾	Ship Weight (with arms):	36
Seat Width:	17½	Ship Weight (armless):	35
Back Width:	19¾	Cube (with arms):	15.8
Back Height:	16¼	Cube (armless):	15.8
Width (with arms):	23½	COM (Seat):	1.0
Width (armless):	19¾	COM (Back):	1.0
Arm Width:	20¼	Weight Rating:	300 lbs.

FABRIC PRICE CODES

1	\$537	
<i>Add to Base Price Above</i>		
	Back	Seat
2	\$18	\$18
3	\$36	\$36
4	\$50	\$50
5	\$63	\$63
6	\$77	\$77
7	\$90	\$90
8	\$104	\$104
9	\$117	\$117
10	\$131	\$131
11	\$144	\$144
12	\$158	\$158

HON Recommendation: HSGS6DF.N.E.CU__CU__PR8 - List Price \$910

HOW TO SPECIFY

<p>Select Model Number</p>	<p>Select Arm Type</p> <p>N Armless F Fixed Arms (+ \$30 per chair)</p>	<p>Select Caster/Glide</p> <p>E Standard Nylon Glide H Hard Caster S Soft Caster (+ \$20 per chair) B Both Hard Casters and Standard Nylon Glides (+ \$20 per chair)</p> <p><i>Options H, S & B available for HSGS6DF model only</i></p>	<p>Select Back Fabric</p> <p>See page 32</p>	<p>Select Seat Fabric</p> <p>See page 32</p>	<p>Select Frame</p> <p>See page 31</p>
H S G S 6 D F .	N .	E .	C U 2 2 .	C U 1 0 .	P R 8



HSCS2DF



CAFÉ-HEIGHT STOOL

Dual Fabric

DIMENSIONS

Depth:	24½	Seat to Floor Height:	31½
Height:	44¾	Usable Seat Depth:	17
Seat Depth:	20¾	Ship Weight (with arms):	38
Seat Width:	17½	Ship Weight (armless):	37
Back Width:	19¾	Cube (with arms):	19.1
Back Height:	16¼	Cube (armless):	19.1
Width (with arms):	23½	COM (Seat):	1.0
Width (armless):	19¾	COM (Back):	1.0
Arm Width:	20¼	Weight Rating:	300 lbs.

FABRIC PRICE CODES

1 \$581

Add to Base Price Above

	Back	Seat
2	\$18	\$18
3	\$36	\$36
4	\$50	\$50
5	\$63	\$63
6	\$77	\$77
7	\$90	\$90
8	\$104	\$104
9	\$117	\$117
10	\$131	\$131
11	\$144	\$144
12	\$158	\$158

HSB50DF

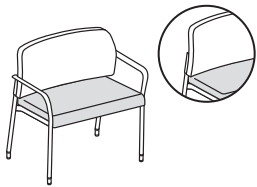

BARIATRIC CHAIR

Dual Fabric

DIMENSIONS

Depth:	21½	Seat to Floor Height:	19
Height:	32½	Usable Seat Depth:	16¾
Seat Depth:	20¼	Ship Weight (with arms):	50
Seat Width:	28	Ship Weight (armless):	49
Back Width:	29	Cube (with arms):	27.2
Back Height:	16½	Cube (armless):	27.2
Width (with arms):	33½	COM (Seat):	1.0
Width (armless):	30	COM (Back):	1.0
Arm Width:	30	Weight Rating:	500 lbs.

FABRIC PRICE CODES

1 \$887

Add to Base Price Above

	Back	Seat
2	\$24	\$24
3	\$48	\$48
4	\$66	\$66
5	\$84	\$84
6	\$102	\$102
7	\$120	\$120
8	\$138	\$138
9	\$156	\$156
10	\$174	\$174
11	\$192	\$192
12	\$210	\$210

HSGANG

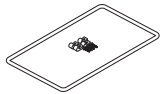

GANGING BRACKET

(hardware included)

DIMENSIONS

Ship Weight: 5 Ⓞ

LIST PRICE

\$34

NOTES: For use on models HSGS6 and HSGS6DF.

ⓘ No specification required for bracket. The ganging bracket is only available in black. The ganging bracket does not work on the bariatric unit.

HON Recommendation: HSCS2DF.N.E.CU__CU__PR8 - List Price \$581

HOW TO SPECIFY

Select Model Number H S C S 2 D F .	Select Arm Type N Armless F Fixed Arms (+ \$30) N .	Select Caster/Glide E Standard Nylon Glide E .	Select Back Fabric See page 32 C U 2 2 .	Select Seat Fabric See page 32 C U 1 0 .	Select Frame See page 31 P R 8
---	---	---	---	---	---



ADJUSTABLE TASK/LAB Stools

HMTS01

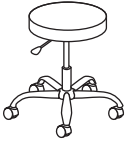

TASK/LAB STOOL

without Back

Pneumatic
Swivel

Functions: **A, E**

(Function Key on pages 16-17)

DIMENSIONS

Depth:	27¼	Seat to Floor Height:	17¾-22
Width:	24⅝	Usable Seat Depth:	16
Height:	17¾-22	Ship Weight:	22 Ⓢ
Seat:	16" Dia.	Cube:	2.5
		Weight Rating:	250 lbs.

FABRIC PRICE CODE

1 \$366

NOTES: EA vinyl is a healthcare covering that meets AATCC Test Method 147-2004.

! Available in polished base ONLY. Available in Grade 1, Black, EA11 fabric ONLY.

HMTS11

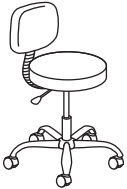

TASK/LAB STOOL

with Back

Pneumatic
Back Height
Seat Depth
Swivel

Functions: **A, B, C, E**

(Function Key on pages 16-17)

DIMENSIONS

Depth:	27¼	Seat to Floor Height:	17¾-22
Width:	24⅝	Usable Seat Depth:	14¾-16
Height:	31½-38	Ship Weight:	29 Ⓢ
Seat:	16" Dia.	Cube:	2.7
Back Width:	15½	Weight Rating:	250 lbs.
Back Height:	8¾-16		

FABRIC PRICE CODE

1 \$490

NOTES: EA vinyl is a healthcare covering that meets AATCC Test Method 147-2004.

! Available in polished base ONLY. Available in Grade 1, Black, EA11 fabric ONLY.

HOW TO SPECIFY

Select Model Number	Select Fabric
	EA11 Black, Grade 1 (only)
H M T S 0 1 .	E A 1 1

ASSEMBLE™ Nesting/Stacking Chairs

OPEN MARKET



Icon Legend on page 15

HVL304



NESTING/STACKING

Upholstered Seat and Mesh
Back
Casters
Armless
Ships 2 per Carton

DIMENSIONS

Depth:	24	Seat to Floor Height:	17
Width:	24	Usable Seat Depth:	17
Height:	34¾	Ship Weight:	57
Seat Depth:	17	Cube:	9.0
Seat Width:	18	Weight Rating:	250 lbs.
Back Width:	16¾		

LIST PRICE PER CARTON

\$547
(reference single unit @
\$273.50

NOTES: Stacks 4-high. Comfortable and breathable mesh back. Armless. Black fabric seat. Specify Black (T) or Silver (X) frame. Ships two per carton. **HON 5-Year Limited Warranty.**

Mesh Nesting Chairs are ordered and shipped two (2) chairs per carton. Pricing shown is per carton. Each set of two chairs (one carton) must have the same fabric/frame color. Ordering 2 of any model will result in 2 cartons being shipped, giving you 4 chairs.

HON Recommendation: HVL304.VA10.T - List Price \$547

HVL314



NESTING/STACKING

Upholstered Seat and Mesh
Back
Casters
Arms
Ships 2 per Carton

DIMENSIONS

Depth:	24	Arm Width:	18
Width:	24	Seat to Floor Height:	17
Height:	34¾	Usable Seat Depth:	17
Seat Depth:	17	Ship Weight:	57
Seat Width:	18	Cube:	9.2
Back Width:	16¾	Weight Rating:	250 lbs.

LIST PRICE PER CARTON

\$572
(reference single unit @
\$286.00

NOTES: Stacks 4-high. Comfortable and breathable mesh back. With arms. Black fabric seat. Specify Black (T) or Silver (X) frame. Ships two per carton. **HON 5-Year Limited Warranty.**

Mesh Nesting Chairs are ordered and shipped two (2) chairs per carton. Pricing shown is per carton. Each set of two chairs (one carton) must have the same fabric/frame color. Ordering 2 of any model will result in 2 cartons being shipped, giving you 4 chairs.

HON Recommendation: HVL314.VA10.T - List Price \$572

HOW TO SPECIFY

Select
Model Number

H V L 3 0 4 .

Select
Fabric

VA10 Black

V A 1 0 .

Select
Frame

T Black
X Silver

T

BODA™



Shown with 10700 Series™ desks.

BODA™

Look cool. Stay cool. Boda task chairs rely on breathable mesh that increases airflow to prevent hot spots and maximize comfort. Each high-back task chair features a mesh back with a choice of mesh seat or upholstered seat for maximum comfort. To take the comfort to an even higher level, the 2-to-1 synchro-tilt recline control provides a stable, comfortable ride, making it perfect for executive offices and meeting spaces.



FEATURES

- Breathable mesh back delivers all-day comfort.
- Mesh seat option is breathable and offers all-day support.
- Upholstered seat option includes ample foam cushioning.
- Responsive synchro-tilt control provides a smooth, natural recline.
- Arms move up or down for shoulder and upper body support.
- Tilt tension controls the rate and ease of recline.
- Tilt lock allows the user to lock out the tilt function.
- One-touch seat height adjustment easily moves the seat up and down.
- 360-degree swivel provides freedom of movement in any direction.
- Warranted for users up to 275 lbs.



HMH01



TASK CHAIR

High-back
 Pneumatic
 Synchro-tilt
 Tilt Tension
 Tilt Lock
 Height-adjustable Arms
 Mesh Sandwich Fabric Seat and Mesh Back

Functions: **A, E, J, K, L, Q**
 (Function Key on pages 16-17)

NOTES: Model HMH01 available with Black Mesh back and Black Sandwich Mesh fabric seat.

! Titanium frame only available on both models.

DIMENSIONS

Depth:	35½	Arm Width:	19¼
Width:	27¾	Seat to Floor Height:	18¼-22½
Height:	44	Usable Seat Depth:	17⅞
Seat Depth:	17⅞	Ship Weight:	43 Ⓢ
Seat Width:	20¾	Cube:	5.1
Back Width:	19¾	Weight Rating:	275 lbs.
Back Height:	24¼		

LIST PRICE

\$815

HMH02



TASK CHAIR

High-back
 Pneumatic
 Synchro-tilt
 Tilt Tension
 Tilt Lock
 Height-adjustable Arms
 Mesh Seat and Back

Functions: **A, E, J, K, L, Q**
 (Function Key on pages 16-17)

NOTES: HMH02 available with Black Mesh seat and back.

! Titanium frame only available on both models.

DIMENSIONS

Depth:	35½	Arm Width:	17½
Width:	27	Seat to Floor Height:	18½-22¾
Height:	44¼	Usable Seat Depth:	18¼
Seat Depth:	18¼	Ship Weight:	44 Ⓢ
Seat Width:	20	Cube:	5.1
Back Width:	19¾	Weight Rating:	275 lbs.
Back Height:	24¾		

LIST PRICE

\$940

HON Recommendation: HMH01.MM10.C - List Price \$815

HOW TO SPECIFY

<p>Select Model Number</p> <p>HMH01</p>	<p>Select Seat</p> <p>MM10 Black Sandwich Mesh — (HMH01 ONLY) MST1 Black Mesh — (HMH02 ONLY)</p> <p>MM10</p>	<p>Select Frame</p> <p>C Titanium</p> <p>C</p>
--	--	--

CAMBIA™ 2160 SERIES



Cambia Upholstered Back Guest Chairs shown with Preside® table.

CAMBIA™ 2160 SERIES

Cambia's comfort and style is a warm invitation for any guest or coworker. With two back variations and arm options, this is a guest chair collection designed to adapt. Each back option offers a choice of a wood slat design or upholstered panel to suit any space or personal taste. Choose from eight rich hardwood finishes and hundreds of quality HON fabrics to express your style and reflect your brand.



FEATURES

- Wood slat back panel complements a variety of surroundings.
- Upholstered seat and back features cushioning for additional comfort and support.
- Personalize your space with a choice of back styles.
- Fixed arms enhance take pressure off the upper body and shoulders.
- Solid hardwood in one of eight attractive finishes.
- Available in hundreds of quality HON fabrics.
- Warranted for users up to 250 lbs.

CAMBIA™

2160 Series Options

MODEL OPTIONS

H2164



Guest Chair

Upholstered Back, Leg Base,
Arch Arms

H2165



Guest Chair

Wood Slat Back, Leg Base,
Arch Arms

AVAILABLE FINISHES

Cambia™ 2160 Series Seating is available in 8 wood finishes.

WOOD FINISHES

Bourbon Cherry (H)

Cognac (COGN)

Harvest (C)

Mahogany (N)

Mocha (MOCH)

Natural Maple (D)

Pinnacle (PINC)

Shaker Cherry (F)

HON BRANDED FABRICS

GRADE 1

Apex
Attire
Centurion
Compass
Contourett
Dapper
Ensemble
Hamilton
Inertia
Optic

GRADE 2

Appoint Seating
Blume
Clyde
Dotty
Rush
Seed
Spin
Whisper Vinyl

GRADE 3

In Season
Purl
Quill
Silvertex™ Vinyl

GRADE L

Denver Leather

For a complete list of fabrics, including partnership fabrics, go to hon.com/fabricsandfinishes.

Reference Fabric Color Combinations on pages 18-22 for color codes and legend on page 19 for lead times. For additional HON to Supply COM fabric grade pricing, go to honready.hon.com and click on the HON to Supply COM link.

🔥 For Fire Code model, availability and ordering method, refer to pages 26-29. Available on select models, contact HON Customer Support for availability.



CAMBIA™ 2160 Series

H2164



GUEST CHAIR

Upholstered Back
Leg Base
Arch Arms

DIMENSIONS

Depth:	24¼	Arm Width:	19
Width:	21¾	Seat to Floor Height:	19
Height:	31¾	Usable Seat Depth:	21
Seat Depth:	21	Ship Weight:	30
Seat Width:	21¾	Cube:	22.6
Back Width:	21¾	COM:	1.5
Back Height:	13¾	Weight Rating:	250 lbs.

FABRIC PRICE CODES

1	\$698	8	\$1043
2	\$758	9	\$1088
3	\$818	10	\$1133
4	\$863	11	\$1178
5	\$908	12	\$1223
6	\$953	L	\$1198
7	\$998		

H2165



GUEST CHAIR

Wood Slat Back
Leg Base
Arch Arms

DIMENSIONS

Depth:	24¼	Arm Width:	19
Width:	21¾	Seat to Floor Height:	19
Height:	31¾	Usable Seat Depth:	21
Seat Depth:	21	Ship Weight:	30
Seat Width:	21¾	Cube:	22.6
Back Width:	21¾	COM:	1.3
Back Height:	13¾	Weight Rating:	250 lbs.

FABRIC PRICE CODES

1	\$736	8	\$943
2	\$772	9	\$970
3	\$808	10	\$997
4	\$835	11	\$1024
5	\$862	12	\$1051
6	\$889	L	\$1036
7	\$916		

HON Recommendation: H2164.MOCH.CU__ - List Price \$698

HOW TO SPECIFY

Select
Model Number

H 2 1 6 4 .

Select
Finish

See page 42

M O C H .

Select
Fabric

See page 42

C U 1 0 .



Task Seating shown with Coordinate™ and Flock®.

CERES®

Seating is personal. At the same time, it's also universal. Ceres is designed to bridge that gap by creating a holistic seating family that allows everyone to stay in control of their own comfort. As the result of exhaustive ergonomic research, the stunning Ceres collection of task and guest chairs feature total support for anyone and any space. The comfort contours cradle you throughout the workday, while projecting the right personality for your brand.



GUEST FEATURES

- 4-Way Stretch mesh back is available in five colors.
- Model HCG6 is a four-leg multi-purpose chair with a pivoting back for added comfort.
- Model HCG6 stacks up to four high on the floor.
- Guest chairs are available with or without arms.
- Available in dual fabric.
- Warranted for users up to 300 lbs.

TASK CHAIR FEATURES

- Height- and width-adjustable arms provide a custom fit.
- Seat depth adjustment adapts to users of various heights.
- One-touch seat height adjustment easily moves the seat up and down.
- Tilt tension controls the rate and ease of recline.
- Tilt lock allows the user to lock the back in multiple recline positions.
- Warranted for users up to 300 lbs.

CERES® Task Chair Options

MODEL OPTION

HCW1



Task Chair

Pneumatic, Swivel, Synchro-tilt,
Seat Glide Tilt Tension, Height,
Width and Depth Adjustable Arms

ARM STYLE

CODE	DESCRIPTION	PRICE
------	-------------	-------



ABLCK	Textured Black	+\$0
--------------	----------------	-------------



APLAT	Textured Platinum Metallic	+\$0
--------------	----------------------------	-------------



APA	Polished Aluminum	+\$50
------------	-------------------	--------------

CASTERS

CODE	DESCRIPTION	PRICE
------	-------------	-------



H	Hard Caster	+\$0
----------	-------------	-------------



S	Soft Caster	+\$30
----------	-------------	--------------

BACK STYLE

CODE	DESCRIPTION	PRICE
------	-------------	-------



PB	Upholstered in-back	+\$0
-----------	---------------------	-------------



4-Way Stretch options:

IM	Black	+\$0
IF	Fog	+\$0
IC	Charcoal	+\$0
IH	Chai	+\$0
IY	Navy	+\$0

BASE

CODE	DESCRIPTION	PRICE
------	-------------	-------



SB	Standard Base	+\$0
-----------	---------------	-------------

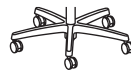

PA	Polished Aluminum	+\$110
-----------	-------------------	---------------

FRAME

CODE	DESCRIPTION	PRICE
------	-------------	-------

T	Black	+\$0
----------	-------	-------------

CERES® Multi-Purpose Chair Options

MODEL OPTION

HCG6



Multi-Purpose

Four-leg stacking frame with pivoting back

HCG6DF - Dual Fabric



Multi-Purpose

Four-leg stacking frame with pivoting back

ARM STYLE

CODE	DESCRIPTION	PRICE
N	Armless	+\$0
F	Fixed Arms	+\$55



BACK STYLE

CODE	DESCRIPTION	PRICE
PB	Upholstered in-back	+\$0



4-Way Stretch options:

IM	Black	+\$0
IF	Fog	+\$0
IC	Charcoal	+\$0
IH	Chai	+\$0
IY	Navy	+\$0



CASTERS/ GLIDE

CODE	DESCRIPTION	PRICE
H	Hard Caster	+\$0
S	Soft Caster	+\$20
E	Glide	+\$0



FRAME

CODE	DESCRIPTION	PRICE
BLCK	Textured Black	+\$0
PLAT	Textured Platinum Metallic	+\$0

HON BRANDED FABRICS

GRADE 1	GRADE 2	GRADE 3	GRADE L
Apex	Appoint Seating	In Season	Denver Leather*
Attire	Blume	Purl	
Centurion	Clyde	Quill	
Compass	Dotty	Silvertex™ Vinyl	
Contourett	Rush		
Dapper	Seed		
Ensemble	Spin		
Hamilton	Whisper Vinyl		
Inertia			
Optic			

For a complete list of fabrics, including partnership fabrics, go to hon.com/fabricsandfinishes.

Reference Fabric Color Combinations on pages 18-22 for color codes and legend on page 19 for lead times. For additional HON to Supply COM fabric grade pricing, go to honready.hon.com and click on the HON to Supply COM link.

*Denver Leather (SS) may not be available on every model within a specific series, please refer to the model's page for details.

 For Fire Code model, availability and ordering method, refer to pages 26-29. Available on select models, contact HON Customer Support for availability.



HCW1



TASK CHAIR

Pneumatic
Swivel
Synchro-tilt
Seat Glide Tilt Tension
Height, Width and Depth
Adjustable Arms
Functions:
A, D, E, A-C, A-D, B-A
(Function Key on pages 16-17)

DIMENSIONS

Depth: 27¾	Seat to Floor Height: 17-21½
Width: 27½	Usable Seat Depth: 17-19½
Height: 43⅞	Ship Weight (upholstered back): 39 Ⓢ
Seat Depth: 19	Ship Weight (mesh back): 39 Ⓢ
Seat Width: 20	Cube (upholstered back): 11.3
Back Width: 16½	Cube (mesh back): 11.3
Back Height: 22½	COM (upholstered back): 1.0
Arm Width: 17½-21	COM (mesh back): 1.0
	Weight Rating: 300 lbs.

FABRIC PRICE CODES

1	\$1309	8	\$1447
2	\$1333	9	\$1465
3	\$1357	10	\$1483
4	\$1375	11	\$1501
5	\$1393	12	\$1519
6	\$1411	L	\$1509
7	\$1429		

HON Recommendation: HCW1.ABLCK.H.IM.CU__SB.T - List Price \$1309

HOW TO SPECIFY

Select Model Number	Select Arm Option	Select Caster/Glide	Select Back Option	Select Fabric	Select Base	Select Frame
Adjustable Arms Finishes ABLCK Textured Black APLAT Textured Platinum Metallic APA Polished Aluminum (+ \$50)	H Hard Caster S Soft Caster (+ \$30)	PB Upholstered in-back Mesh Back Options IM Black IF Fog IC Charcoal IH Chai IY Navy	See page 47	SB Standard Base PA Polished Aluminum (+ \$110)	T Black	
HCW1	ABLCK	H	IM	CU10	SB	T



Icon Legend on page 15

HCG6

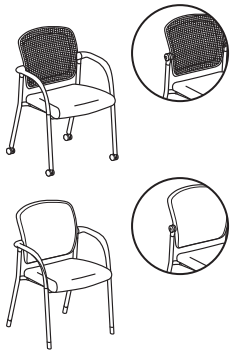

MULTI-PURPOSE

Four-leg stacking frame with pivoting back

DIMENSIONS

Depth:	25	Seat to Floor Height:	18¾
Width:	24½	Usable Seat Depth:	17¼
Height:	35	Ship Weight (upholstered back):	22
Seat Depth:	19½	Ship Weight (mesh back):	22
Seat Width:	20	Cube (upholstered back):	15.2
Back Width:	17½	Cube (mesh back):	15.2
Back Height:	17	COM (upholstered back):	1.0
Arm Width:	20¼	COM (mesh back):	1.0
		Weight Rating:	300 lbs.

FABRIC PRICE CODES

1	\$540	8	\$678
2	\$564	9	\$696
3	\$588	10	\$714
4	\$606	11	\$732
5	\$624	12	\$750
6	\$642	L	\$740
7	\$660		

NOTES: Multi-purpose model HCG6, with or without arms, stacks up to 4-high.

HON Recommendation: HCG6.F.H.IM.CU__BLCK - List Price \$595

HOW TO SPECIFY

<p>Select Model Number</p> <p>HCG6</p>	<p>Select Arm Option</p> <p>F Fixed Arms (+ \$55) N Armless</p> <p>F</p>	<p>Select Caster/Glide</p> <p>E Glide H Hard Caster S Soft Caster (+ \$20)</p> <p>H</p>	<p>Select Back Option</p> <p>PB Upholstered in-back Mesh Back Options IM Black IF Fog IC Charcoal IH Chai IY Navy</p> <p>IM</p>	<p>Select Fabric</p> <p>See page 47</p> <p>CU10</p>	<p>Select Frame</p> <p>BLCK Textured Black PLAT Textured Platinum Metallic</p> <p>BLCK</p>
---	---	---	--	--	---

HCG6DF



MULTI-PURPOSE

Dual Fabric
Four-leg stacking frame with pivoting back

DIMENSIONS

Depth:	25	Arm Width:	20¼
Width:	24½	Seat to Floor Height:	18¾
Height:	35	Usable Seat Depth:	17¼
Seat Depth:	19½	Ship Weight (upholstered back):	22
Seat Width:	20	Cube (upholstered back):	15.2
Back Width:	17½	COM (back):	0.8
Back Height:	17	COM (seat):	1.0
		Weight Rating:	300 lbs.

FABRIC PRICE CODES

1	\$615		
		<i>Add to Base Price Above</i>	
		Back	Seat
2	\$18	\$24	
3	\$36	\$48	
4	\$50	\$66	
5	\$63	\$84	
6	\$77	\$102	
7	\$90	\$120	
8	\$104	\$138	
9	\$117	\$156	
10	\$131	\$174	
11	\$144	\$192	
12	\$158	\$210	
L	\$150	\$200	

NOTES: Multi-purpose model HCG6DF, with or without arms, stacks up to 4-high.

HON Recommendation: HCG6DF.F.H.PB.CU__CU__BLCK - List Price \$712

HOW TO SPECIFY

<p>Select Model Number</p> <p>HCG6DF</p>	<p>Select Arm Option</p> <p>F Fixed Arms (+ \$55) N Armless</p> <p>F</p>	<p>Select Caster/Glide</p> <p>E Glide H Hard Caster S Soft Caster (+ \$20)</p> <p>H</p>	<p>Select Back Option</p> <p>PB Upholstered in-back</p> <p>PB</p>	<p>Select Back Fabric</p> <p>See page 47</p> <p>CU22</p>	<p>Select Seat Fabric</p> <p>See page 47</p> <p>CU10</p>	<p>Select Frame</p> <p>BLCK Textured Black PLAT Textured Platinum Metallic</p> <p>BLCK</p>
---	---	---	---	---	---	---



Icon Legend on page 15

CHARGE™

HVL643



GUEST CHAIR

4-Leg Base
Padded Arms

DIMENSIONS

Depth:	28½	Arm Width:	18½
Width:	24½	Seat to Floor Height:	19½
Height:	34½	Usable Seat Depth:	19½
Seat Depth:	19½	Ship Weight:	36
Seat Width:	19	Cube:	4.5
Back Width:	21¼	Weight Rating:	250 lbs.
Back Height:	18		

PRICE CODE

Leather **\$339**

NOTES: Black SofThread™ Leather with pleated stitching detail. Black frame. **HON 5-Year Limited Warranty.**

HON Recommendation: HVL643.SB11 - List Price \$339

HOW TO SPECIFY

<p>Select Model Number</p>	<p>Select Fabric</p> <p>SB11 Black SofThread™ Leather</p>
<p>H V L 6 4 3 .</p>	<p>S B 1 1</p>



HVL871

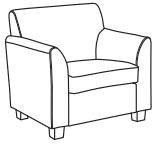

CLUB CHAIR

DIMENSIONS

Depth:	28¾	Arm Width:	21½
Width:	33	Seat to Floor Height:	18½
Height:	32	Usable Seat Depth:	21
Seat Depth:	21	Ship Weight:	51
Seat Width:	21½	Cube:	20.7
Back Width:	30	Weight Rating:	250 lbs.
Back Height:	18½		

PRICE CODE

Leather **\$1246**

NOTES: Legs available in Black. Legs ship unattached. Available in SB11 SofThread™ Leather only. **HON 5-Year Limited Warranty.**

HON Recommendation: HVL871.SB11 - List Price \$1246

HVL872

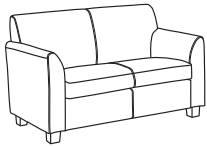

LOVE SEAT

DIMENSIONS

Depth:	28¾	Arm Width:	42
Width:	53½	Seat to Floor Height:	18½
Height:	32	Usable Seat Depth:	21
Seat Depth:	21	Ship Weight:	76
Seat Width:	42	Cube:	33.1
Back Width:	50	Weight Rating:	250 lbs.
Back Height:	18½		

PRICE CODE

Leather **\$1581**

NOTES: Legs available in Black. Legs ship unattached. Available in SB11 SofThread™ Leather only. **HON 5-Year Limited Warranty.**

HON Recommendation: HVL872.SB11 - List Price \$1581

HVL873

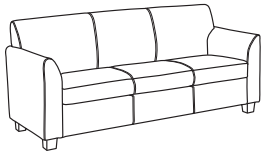

SOFA

DIMENSIONS

Depth:	28¾	Arm Width:	61½
Width:	73	Seat to Floor Height:	18½
Height:	32	Usable Seat Depth:	21
Seat Depth:	21	Ship Weight:	122
Seat Width:	61½	Cube:	45.0
Back Width:	70	Weight Rating:	250 lbs.
Back Height:	18½		

PRICE CODE

Leather **\$1975**

NOTES: Legs available in Black. Legs ship unattached. Available in SB11 SofThread™ Leather only. **HON 5-Year Limited Warranty.**

HON Recommendation: HVL873.SB11 - List Price \$1975

HOW TO SPECIFY

Select
Model Number

Select
Fabric

SB11 Black SofThread™ Leather

H V L 8 7 1 . S B 1 1



CLIENT™

HVL691



HIGH-BACK

Pneumatic
Swivel
Tilt
Tilt Tension
Tilt Lock
Fixed Padded Arms
Functions: **A, E, F, K, L**
(Function Key on pages 16-17)

DIMENSIONS

Depth:	28¾	Arm Width:	21
Width:	27	Seat to Floor Height:	18¾-21¾
Height:	47¼	Usable Seat Depth:	17¾
Seat Depth:	20¼	Ship Weight:	50 Ⓢ
Seat Width:	21½	Cube:	7.2
Back Width:	21½	Weight Rating:	250 lbs.
Back Height:	27		

PRICE CODE

Leather \$571

NOTES: Black SofThread™ Leather. Sturdy textured black frame. Fixed padded loop arms. Built-in lumbar support. Use with coordinating Guest Chair model HVL693 shown below. **HON 5-Year Limited Warranty.**

HON Recommendation: HVL691.SB11 - List Price \$571

HVL693



GUEST CHAIR

Sled Base
Padded Arms

DIMENSIONS

Depth:	26	Arm Width:	18½
Width:	24¾	Seat to Floor Height:	18¼
Height:	33½	Usable Seat Depth:	18¼
Seat Depth:	18¼	Ship Weight:	38 Ⓢ
Seat Width:	20¾	Cube:	5.2
Back Width:	21	Weight Rating:	250 lbs.
Back Height:	16¼		

PRICE CODE

Leather \$369

NOTES: Black SofThread™ Leather with tailored stitching detail. Sturdy textured black frame. Built-in lumbar support. Use with coordinating Executive Chair model HVL691 shown above. **HON 5-Year Limited Warranty.**

HON Recommendation: HVL693.SB11 - List Price \$369

HOW TO SPECIFY

<p>Select Model Number</p>	<p>Select Fabric</p> <p>SB11 Black SofThread™ Leather</p>
<p>H V L 6 9 1 .</p>	<p>S B 1 1</p>

COMFORTASK® 5900 SERIES



ComforTask Chair shown
with Metro Classic desks.

COMFORTASK® 5900 SERIES

What's in a name? If it's ComforTask, it's the support you need to get the job done. ComforTask seating is a proven office performer, with cushioning in all the right places, a waterfall seat edge and the customizable comfort that allows everyone to create a personal fit. Advanced controls such as back height and seat depth adjustments take the personalization to an even higher level, earning fans throughout the office.



FEATURES

- Back height adjustment moves the back up or down to provide a custom fit.
- Seat depth adjustment on Model H5901 adapts to users of various heights.
- Contoured seat and back provide targeted support.
- Waterfall seat edge encourages leg circulation.
- One-touch seat height adjustment easily moves the seat up and down.
- 360-degree swivel provides freedom of movement in any direction.
- Molded polymer outer back for added durability.
- Available in hundreds of quality HON fabrics.
- Warranted for users up to 300 lbs.

COMFORTASK® 5900 Series Options

MODEL OPTIONS

H5901



Task Chair

Pneumatic, Back Height, Seat Depth, Swivel

H5902



Task Chair

Pneumatic, Back Height, Swivel, Tilt, Tilt Tension, Tilt Lock

H5903



Task Chair

Pneumatic, Back Height, Swivel, Multi-task

H5905



Task Stool

Pneumatic, Back Height, Swivel, Adjustable Height Footring

CASTERS/ GLIDE



CODE	DESCRIPTION	PRICE
H	Hard Caster	+\$0



S	Soft Caster	+\$30
----------	-------------	--------------



G	Bell Glide	+\$25
----------	------------	--------------

*G only available on model H5905

FRAME

CODE	DESCRIPTION	PRICE
T	Black	+\$0

COMFORTASK®

5900 Series Fabric Options

HON BRANDED FABRICS

GRADE 1

Apex
Attire
Centurion
Compass
Contourett
Dapper
Ensemble
Hamilton
Inertia
Optic

GRADE 2

Appoint Seating
Blume
Clyde
Dotty
Rush
Seed
Spin
Whisper Vinyl

GRADE 3

In Season
Purl
Quill
Silvertex™ Vinyl

For a complete list of fabrics, including partnership fabrics, go to hon.com/fabricsandfinishes.

Reference Fabric Color Combinations on pages 18-22 for color codes and legend on page 19 for lead times. COM yardage shown is for Pattern Cut only. Contact Customer Service for Railroaded yardage requirements. For additional HON to Supply COM fabric grade pricing, go to honready.hon.com and click on the HON to Supply COM link.

 For Fire Code model, availability and ordering method, refer to pages 26-29. Available on select models, contact HON Customer Support for availability.

COMFORTASK® 5900 Series

GSA SIN 33721



Icon Legend on page 15

H5901



TASK

Pneumatic
Back Height
Seat Depth
Swivel
Functions: **A, B, C, E**
(Function Key on pages 16-17)

NOTES: Seat depth adjustment.

DIMENSIONS

Depth: 28³/₄ Seat to Floor Height: 14⁷/₈-19³/₄
Width: 23 Usable Seat Depth: 16³/₈-18¹/₈
Height: 38¹/₄ Ship Weight: 30 **Ⓢ**
Seat Depth: 18 Cube: 7.8
Seat Width: 20 COM: 1.0
Back Width: 16¹/₄ Weight Rating: 300 lbs.
Back Height: 17³/₄

FABRIC PRICE CODES

1	\$294	8	\$432
2	\$318	9	\$450
3	\$342	10	\$468
4	\$360	11	\$486
5	\$378	12	\$504
6	\$396	L	—
7	\$414		

H5902



TASK

Pneumatic
Back Height
Swivel
Tilt
Tilt Tension
Tilt Lock
Functions: **A, B, E, F, K, L**
(Function Key on pages 16-17)

DIMENSIONS

Depth: 27³/₄ Seat to Floor Height: 17-22
Width: 23 Usable Seat Depth: 16³/₄
Height: 39³/₄ Ship Weight: 30 **Ⓢ**
Seat Depth: 18 Cube: 7.8
Seat Width: 20 COM: 1.0
Back Width: 16¹/₄ Weight Rating: 300 lbs.
Back Height: 21

FABRIC PRICE CODES

1	\$312	8	\$450
2	\$336	9	\$468
3	\$360	10	\$486
4	\$378	11	\$504
5	\$396	12	\$522
6	\$414	L	—
7	\$432		

H5903



TASK

Pneumatic
Back Height
Swivel
Multi-task
Functions: **A, B, E, N**
(Function Key on pages 16-17)

DIMENSIONS

Depth: 34¹/₄ Seat to Floor Height: 16¹/₄-20¹/₈
Width: 24 Usable Seat Depth: 13³/₄-17
Height: 40¹/₂ Ship Weight: 32 **Ⓢ**
Seat Depth: 18 Cube: 7.8
Seat Width: 20 COM: 1.0
Back Width: 16¹/₄ Weight Rating: 300 lbs.
Back Height: 20¹/₄

FABRIC PRICE CODES

1	\$441	8	\$579
2	\$465	9	\$597
3	\$489	10	\$615
4	\$507	11	\$633
5	\$525	12	\$651
6	\$543	L	—
7	\$561		

HON Recommendation: H5901.H.CU__T with optional H5995 - List Price \$409

HOW TO SPECIFY

Select Model Number <div style="border: 1px solid black; padding: 2px; display: flex; gap: 5px;"> H5901 </div>	Select Caster/Glide H Hard Caster S Soft Caster (+ \$30) <div style="border: 1px solid black; padding: 2px; display: flex; gap: 5px;"> H </div>	Select Fabric See page 55 <div style="border: 1px solid black; padding: 2px; display: flex; gap: 5px;"> CU10 </div>	Select Frame T Black <div style="border: 1px solid black; padding: 2px; display: flex; gap: 5px;"> T </div>
---	--	--	--



Icon Legend on page 15

COMFORTASK® 5900 Series

H5905



TASK STOOL

Pneumatic
Back Height
Swivel
Adjustable Height Footring
Functions: **A, B, E**
(Function Key on pages 16-17)

DIMENSIONS

Depth:	30	Seat to Floor Height:	21¾-31½
Width:	26¾	Footring Width:	20
Height:	49¾	Footring Height:	12-14½
Seat Depth:	18	Usable Seat Depth:	17
Seat Width:	20	Ship Weight:	34 Ⓢ
Back Width:	16¼	Cube:	10.4
Back Height:	17¾	COM:	1.0
		Weight Rating:	300 lbs.

FABRIC PRICE CODES

1	\$427	8	\$565
2	\$451	9	\$583
3	\$475	10	\$601
4	\$493	11	\$619
5	\$511	12	\$637
6	\$529	L	—
7	\$547		

NOTES: Available with optional Bell Glides.

H5991



T-ARMS

Fixed Position

DIMENSIONS

Arm Width:	18¾
Height from Seat:	8½
Ship Weight:	6 Ⓢ
Cube:	1.0

LIST PRICE

\$79

H5995



ADJUSTABLE HEIGHT ARMS

Functions: **Q**
(Function Key on pages 16-17)

DIMENSIONS

Arm Width:	18¾
Height from Seat:	6½-8¾
Ship Weight:	8 Ⓢ
Cube:	0.6

LIST PRICE

\$115

HOW TO SPECIFY

<p>Select Model Number</p> <p>H 5 9 0 5 .</p>	<p>Select Caster/Glide</p> <p>H Hard Caster S Soft Caster (+ \$30) <i>Specify for model H5905 only</i> G Bell Glide (+ \$25)</p> <p>H .</p>	<p>Select Fabric</p> <p>See page 55</p> <p>C U 1 0 .</p>	<p>Select Frame</p> <p>T Black</p> <p>T</p>
--	---	---	---

CONVERGENCE®



Convergence® Task Chairs shown with Empower® Height-Adjustable Workstations.

CONVERGENCE®

What happens when support and affordability come together? Convergence. This is the task chair that is as attainable as it is comfortable with customizable features. Lumbar support that adds a little extra lower back comfort. Thick seat cushions to take the stress off the lower body throughout the day. Arm choices that let you decide how much upper body support you want. A breathable mesh back that flexes and responds to your movements. Convergence puts all the features you're looking for into one low-priced task chair.



FEATURES

- Choice of swivel tilt or synchro-tilt control with seat slide.
- Black mesh back is breathable for all-day comfort and support.
- Comfort options include adjustable lumbar support, adjustable arms, seat glide and synchro-tilt.
- Three arm options.
- Two control options.
- Integrated handle on the back makes it easy to move and reposition the chair.
- Hard casters move effortlessly on any surface.
- Black frame sits atop a durable five-star base.
- Warranted for users up to 275 lbs.
- 3" thick seat cushion.







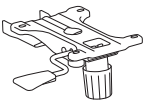

BACK OPTIONS

HCT1MM

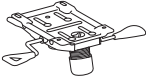

Mid-back

Mesh Task Chair
with Adjustable
Lumbar Support

MECHANISM				BACK STYLE			
	CODE	FUNCTIONS	PRICE		CODE	DESCRIPTION	PRICE
	ZI	Swivel-Tilt Control A, E, F, K, L, W	+\$0		M	Mesh	+\$0
	YI	Limited Synchro-Tilt A, D, E, J, K, L, W	+\$35				
(See pages 16-17 for Seating Functions.)				BASE			
	CODE	DESCRIPTION	PRICE		CODE	DESCRIPTION	PRICE
	N	Armless	+\$0		SB	Standard Base	+\$0
	H	Height-Adjustable Arms	+\$45				
ARM STYLE				LUMBAR			
	CODE	DESCRIPTION	PRICE		CODE	DESCRIPTION	PRICE
	A	Height and Width Adjustable Arms	+\$75		AL	Adjustable Lumbar	+\$0
							
CASTERS				FRAME			
	CODE	DESCRIPTION	PRICE		CODE	DESCRIPTION	PRICE
	H	Hard Casters	+\$0		T	Black	+\$0

CONVERGENCE®

Fabric Options

HON BRANDED FABRICS

GRADE 1

Apex
Attire
Centurion
Compass
Contourett
Dapper
Ensemble
Hamilton
Inertia
Optic

GRADE 2

Appoint Seating
Blume
Clyde
Dotty
Rush
Seed
Spin
Whisper Vinyl

GRADE 3

In Season
Purl
Quill
Silvertex™ Vinyl

For a complete list of fabrics, including partnership fabrics, go to hon.com/fabricsandfinishes.

Reference Fabric Color Combinations on pages 18-22 for color codes and legend on page 19 for lead times. For additional HON to Supply COM fabric grade pricing, go to honready.hon.com and click on the HON to Supply COM link.



CONVERGENCE® Standard Task Chairs

HCT1MM



MID-BACK TASK

Mesh Back
Pneumatic
Swivel
Tilt Tension
Tilt Lock
Adjustable Lumbar Support
Functions: **A, E, K, L, W**
(Function Key on pages 16-17)

DIMENSIONS

Depth:	27½	Adjustable Arms Width:	20
Width:	27¾	Seat to Floor Height:	15¾-20
Height:	42	Usable Seat Depth:	17-19
Seat Depth:	19	Ship Weight:	44
Seat Width:	20	Cube:	5.8
Back Width:	18	COM:	1.0
Back Height:	22	Weight Rating:	275 lbs.

FABRIC PRICE CODES

1	\$334	7	\$394
2	\$346	8	\$403
3	\$358	9	\$412
4	\$367	10	\$421
5	\$376	11	\$430
6	\$385	12	\$439

NOTES: Arm width adjustment range is 3" (from 17"-20"). Lumbar adjustment is 3". Seat depth range is only for Y1 control. Seat depth on Z1 control is 19".

HSCASTER

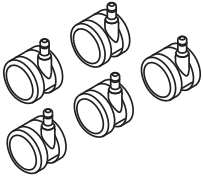

SET OF 5 SOFT CASTERS

DIMENSIONS

Size: 60mm
Ship Weight: 2.5
Cube: 0.1

LIST PRICE

\$50

! Available in Black finish only, no specification needed.

HON Recommendation: HCT1MM.Y1.A.H.M.CU10.AL.SB.T - List Price \$444

HOW TO SPECIFY

Select Model Number	Select Control Type	Select Arm Type	Select Caster	Select Back Type	Select Upholstery	Select Lumbar	Select Base	Select Frame
Z1 Swivel-Tilt Control Y1 Simple Synchro-Tilt w/ Seat Slide Control (+ \$35)	N Armless H Height-Adjustable Arms (+ \$45) A Height & Width Adjustable Arms (+ \$75)	H Hard Casters	M Mesh	See page 60	AL Adjustable Lumbar	SB Standard Base	T Black	
HCT1MM	Y1	A	H	M	CU10	AL	SB	T

CONVERGENCE® Value Task Chairs

OPEN MARKET



Icon Legend on page 15

HCAT1MM



MID-BACK TASK VALUE MODEL

Mesh Back
Pneumatic
Swivel
Tilt Tension
Tilt Lock
Adjustable Lumbar Support

Functions: **A, E, K, L, W**
(Function Key on pages 16-17)

NOTES: Lumbar adjustment is 3". Seat depth range is only for Y1 control. Seat depth on Z1 control is 19".

DIMENSIONS

Depth:	27½	Adjustable Arms Width:	17-20
Width:	27¾	Seat to Floor Height:	15¾-20
Height:	42	Usable Seat Depth:	17-19
Seat Depth:	19	Ship Weight:	44
Seat Width:	20	Cube:	5.8
Back Width:	18	Weight Rating:	275 lbs.
Back Height:	22		

LIST PRICE

\$378

HSCASTER

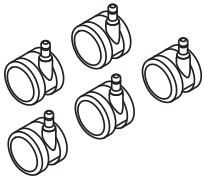

SET OF 5 SOFT CASTERS

DIMENSIONS

Size:	60mm
Ship Weight:	2 S
Cube:	0.1

LIST PRICE

\$50

i Available in Black finish only, no specification needed.

HON Recommendation: HCAT1MM.Z1.A.H.M.ACCF10.AL.SB.T - List Price \$378

HOW TO SPECIFY

Select Model Number	Select Control Type	Select Arm Type	Select Caster	Select Back Type	Select Upholstery	Select Lumbar	Select Base	Select Frame
Z1 Swivel-Tilt Control Y1 Simple Synchro-Tilt w/ Seat Slide Control (+ \$35)	A Height & Width Adjustable Arms	H Hard Casters	M Mesh	ACCF10 Black	AL Adjustable Lumbar	SB Standard Base	T Black	
HCAT1MM	Y1	A	H	M	ACCF10	AL	SB	T



Icon Legend on page 15

CORRAL™ Contemporary Lounge

HVL887

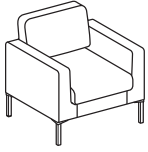

CLUB CHAIR

DIMENSIONS

Depth:	28	Arm Width:	22¼
Width:	31½	Seat to Floor Height:	17⅞
Height:	30½	Usable Seat Depth:	19¾
Seat Depth:	19¾	Ship Weight:	51 Ⓢ
Seat Width:	22¼	Cube:	8.9
Back Width:	22¼	Weight Rating:	250 lbs.
Back Height:	17½		

PRICE CODE

Leather \$957

NOTES: Legs available in Platinum. Legs and back ship unattached. Pair with contemporary occasional tables on page 64. **HON 5-Year Limited Warranty.**

ⓘ Available in SB11 SofThread™ Leather only.

HON Recommendation: HVL887.SB11 - List Price \$957

HVL888

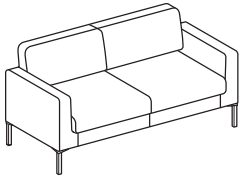

SOFA

DIMENSIONS

Depth:	28	Arm Width:	55
Width:	67	Seat to Floor Height:	17⅞
Height:	30½	Usable Seat Depth:	19¾
Seat Depth:	19¾	Ship Weight:	78
Seat Width:	55	Cube:	18.3
Back Width:	55	Weight Rating:	250 lbs.
Back Height:	17½		

PRICE CODE

Leather \$1226

NOTES: Legs available in Platinum. Legs and back ship unattached. Pair with contemporary occasional tables on page 64. **HON 5-Year Limited Warranty.**

ⓘ Available in SB11 SofThread™ Leather only.

HON Recommendation: HVL888.SB11 - List Price \$1226

HOW TO SPECIFY

Select Model Number

Select Fabric

SB11 Black SofThread™ Leather

H V L 8 8 7 .

S B 1 1

CONTEMPORARY OCCASIONAL TABLES

OPEN MARKET



Icon Legend on page 15

HML8851

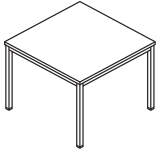

LAMINATE CORNER TABLE DIMENSIONS

Depth:	24	Ship Weight:	24 Ⓢ
Width:	24	Cube:	1.7

LIST PRICE

\$194

NOTES: Metal leg occasional tables available in Black laminate. Choose from Corner or Coffee Table options. **HON 5-Year Limited Warranty.**

HON Recommendation: HML8851.P - List Price \$194

HML8852

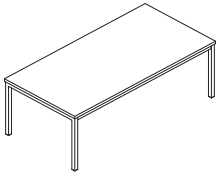

LAMINATE COFFEE TABLE DIMENSIONS

Depth:	24	Ship Weight:	38 Ⓢ
Width:	48	Cube:	3.1

LIST PRICE

\$244

NOTES: Metal leg occasional tables available in Black laminate. Choose from Corner or Coffee Table options. **HON 5-Year Limited Warranty.**

HON Recommendation: HML8852.P - List Price \$244

HOW TO SPECIFY

Select Model Number <div style="border: 1px solid #ccc; display: flex; justify-content: space-between; padding: 2px;"> HML8851 </div>	Select Laminate <div style="border: 1px solid #ccc; display: flex; justify-content: space-between; padding: 2px;"> P </div>
--	--



HVL581



HIGH-BACK

Pneumatic
Swivel
Tilt
Tilt Tension
Tilt Lock
Height and Width Adjustable Arms
Adjustable Lumbar

Functions: **A, E, F, K, L, S, W**
(Function Key on pages 16-17)

DIMENSIONS

Depth:	25½	Arm Width:	19⅞
Width:	28¾	Seat to Floor Height:	16½-20¼
Height:	42⅞	Usable Seat Depth:	17¼
Seat Depth:	17¼	Ship Weight:	39.8 Ⓢ
Seat Width:	20¼	Cube:	4.8
Back Width:	18½	Weight Rating:	250 lbs.

PRICE CODE

Fabric	\$362
Leather	\$387

NOTES: Comfortable and breathable mesh back. Black fabric or Black SofThread™ Leather. Black frame. Height and width adjustable arms. Adjustable lumbar. **HON 5-Year Limited Warranty.**

HON Recommendation: HVL581.ES10.T - List Price \$362

HVL582



HIGH-BACK

Pneumatic
Swivel
Tilt
Tilt Tension
Tilt Lock
Asynchronous Control
Seat Glide Mechanism
Adjustable Lumbar
Height and Width Adjustable Arms

Functions: **A, E, F, L, O, S, W**
(Function Key on pages 16-17)

DIMENSIONS

Depth:	27½	Arm Width:	19⅞
Width:	28¾	Seat to Floor Height:	20½-22⅞
Height:	43¾	Usable Seat Depth:	17¼
Seat Depth:	17¼	Ship Weight:	50.4 Ⓢ
Seat Width:	19⅞	Cube:	6.8
Back Width:	18½	Weight Rating:	250 lbs.

PRICE CODE

Fabric	\$446
Leather	\$471

NOTES: Comfortable and breathable mesh back. Black fabric or Black SofThread™ Leather. Black frame. Height and width adjustable arms. Seat glide mechanism. Asynchronous control with independent seat and back angle adjustment. Adjustable lumbar. **HON 5-Year Limited Warranty.**

HON Recommendation: HVL582.ES10.T - List Price \$446

HVL585



EXECUTIVE BIG AND TALL

Pneumatic
Swivel
Tilt
Tilt Tension
Tilt Lock
Height and Width Adjustable Arms
Adjustable Lumbar

Functions: **A, E, F, K, L, S, W**
(Function Key on pages 16-17)

DIMENSIONS

Depth:	29⅞	Arm Width:	20½
Width:	28⅞	Seat to Floor Height:	17⅞-21¾
Height:	45⅞	Usable Seat Depth:	19⅞
Seat Depth:	19⅞	Ship Weight:	55.4 Ⓢ
Seat Width:	22	Cube:	7.2
Back Width:	20⅞	Weight Rating:	450 lbs.

PRICE CODE

Fabric	\$628
---------------	--------------

NOTES: Large scale model HVL585 will support 450 lbs with normal use. Black fabric. Black frame. Height and width adjustable arms. Adjustable lumbar. **HON 5-Year Limited Warranty.**

! Available in Black fabric only.

HON Recommendation: HVL585.ES10.T - List Price \$628

HOW TO SPECIFY

Select Model Number

H V L 5 8 1 .

Select Fabric

ES10 Black
SB11 Black SofThread™ Leather
Available on HVL581 and HVL582 only

E S 1 0 .

Select Frame

T Black

T

DEFINE™ Executive Chairs

OPEN MARKET



Icon Legend on page 15

HVL108



HIGH-BACK

Pneumatic
Swivel
Synchro-tilt
Height-adjustable Arms
Functions: **A, E, J, K, Q**
(Function Key on pages 16-17)

DIMENSIONS

Depth:	29 ³ / ₄	Arm Width:	19 ¹ / ₂
Width:	29 ³ / ₄	Seat to Floor Height:	17 ¹ / ₈ -21 ³ / ₈
Height:	46 ⁷ / ₈	Usable Seat Depth:	17 ¹ / ₂
Seat Depth:	17 ¹ / ₂	Ship Weight:	47.3 Ⓢ
Seat Width:	21	Cube:	7.2
Back Width:	20	Weight Rating:	250 lbs.
Back Height:	26 ¹ / ₂		

PRICE CODE

Leather **\$559**

NOTES: Available in Black SofThread™ Leather. Polished base. Polished arm accents. Height-adjustable arms. **HON 5-Year Limited Warranty.**

HON Recommendation: HVL108.SB11 - List Price \$559

HOW TO SPECIFY

<p>Select Model Number</p>	<p>Select Fabric</p> <p>SB11 Black SofThread™ Leather</p>
<p>H V L 1 0 8 .</p>	<p>S B 1 1</p>

ENDORSE® COLLECTION



Endorse® Mid-Back Task Chair
shown with Preside® Conference Table.

ENDORSE® COLLECTION

You need inviting, comfy seats up front, and task chairs that support productivity in workstations. Achieve harmony throughout your space with a multi-functional collection of Endorse task seating. Endorse supports the diversity of applications throughout your workplace with sophisticated design. Varied options. Diverse materials. Simply pick the model that suits your space and people. Add the options that fit your needs. Then get ready to Endorse a higher level of productivity.



TASK CHAIR FEATURES

- Available in high-, mid- and low-back options.
- Available in three different back materials — upholstered, mesh and plastic outer back.
- Comfort options include adjustable lumbar support, adjustable arms, seat glide, multi-position tilt and synchro-tilt.
- Optional seat slide adjustment adapts to users of various heights.
- Control options include limited synchro-tilt, advanced synchro-tilt, advanced synchro-tilt with independent back angle and weight-activated control.
- Arm options include fixed, armless, height- and width-adjustable and all-adjustable.
- Caster options include hard, soft and roll-control.
- Available in hundreds of quality HON fabrics.
- Warranted for users up to 300 lbs.
(450 lbs. for Big and Tall chairs)

ENDORSE® Options

BACK OPTIONS

HLEU
HLEUBT - Big & Tall



High-back

Upholstered with Adjustable Lumbar Support

HLWU
HLWUBT - Big & Tall



Mid-back

Upholstered with Adjustable Lumbar Support

HLWM
HLWMBT - Big & Tall



Mid-back

Mesh with Adjustable Lumbar Support

HLTU
HLTSU - Stool



Low-back

Upholstered with Adjustable Lumbar Support

HLTM
HLTSM - Stool



Low-back

Mesh with Adjustable Lumbar Support

HLTP
HLTSP - Stool



Low-back

Upholstered with Plastic Outer Back and Adjustable Lumbar Support

MESH BACK COLOR CODES (no upcharge): Black - **IM** Fog - **IF** Charcoal - **IC** Chai - **IH** Navy - **IY**

MECHANISM

MECHANISM	CODE	FUNCTIONS	PRICE
	S0	Limited Recline Synchro-Tilt A, E, J, K, L	+\$0
	S1	Limited Recline Synchro-Tilt w/ Seat Slider (available on Stools only) A, D, E, J, K, L	+\$20
	Y2	Advanced Synchro-Tilt A, D, E, J, L, W, A-D	+\$65
	Y3	Advanced Synchro-Tilt with Independent Back Angle A, D, E, J, L, W, A-E	+\$105
	Y4	Synchro-Tilt A, D, E, J, L, W, A-D (Big and Tall models only)	+\$0
	W5	Weight-Activated A, D, E, L, W, A-D	+\$150

(See pages 16-17 for Seating Functions.)

BASE

BASE	CODE	DESCRIPTION	PRICE
	SB	Standard Base	+\$0
	PA	Polished Aluminum	+\$110

ARM STYLE

ARM STYLE	CODE	DESCRIPTION	PRICE
	N	Armless	+\$0
	F	Fixed - Black	+\$65
	A	Height and Width Adjustable Arms	+\$75
	V	All-Adjustable Arms - includes pivot	+\$115
	P	Fixed - Polished Alum.	+\$150

CASTERS

CASTERS	CODE	DESCRIPTION	PRICE
	A	All-Surface Caster (High-back and Big and Tall models only)	+\$0
	H	Hard Caster	+\$0
	S	Soft Caster	+\$30
	R	Roll Control Caster	+\$50

TASK DIMENSIONS

MODEL		HLEU	HLWU	HLWM	HLTU	HLTM	HLTP
Overall Width Armless		28½	28½	28½	28½	28½	28½
Overall Width with Arms	A/V	28½	28½	28½	28½	28½	28½
	F/P	28½	28½	28½	28½	28½	28½
Overall Depth		28½	28½	28½	28½	28½	28½
Overall Height	S0	49	45½	45½	42	42	42
	Y2	49¾	46¼	46¼	42¾	42¾	42¾
	Y3	49½	46	46	42½	42½	42½
	W5	49	48⅜	48⅜	43	43	43
Seat Width		20	20	20	19	19	19
Seat Depth		18½	18½	18½	18⅝	18⅝	18⅝
Usable Seat Depth	S0	17¾	17¾	17¾	17⅝	17⅝	17⅝
	Y2	15½-18	15½-18	15½-18	15½-18	15½-18	15½-18
	Y3	15¼-18¼	15¼-18¼	15¼-18¼	15¼-18¼	15¼-18¼	15¼-18¼
	W5	15½-17¾	15½-17¾	15½-17¾	15½-17¾	15½-17¾	15½-17¾
Seat Height (mechanism)	S0	17-21½	17-21½	17-21½	17-21½	17-21½	17-21½
	Y2	17¾-22¼	17¾-22¼	17¾-22¼	17¾-22¼	17¾-22¼	17¾-22¼
	Y3	17½-22	17½-22	17½-22	17½-22	17½-22	17½-22
	W5	17¼-21¾	17¼-21¾	17¼-21¾	17¼-21¾	17¼-21¾	17¼-21¾
Back Width		21⅝	21¼	19¼	19¾	18	19¾
Back Height		29¾	25	25	22¾	21¼	22¾
Ship Weight Armless	S0	52	43	40	49	41	50
	Y2	57 Ⓢ	48 Ⓢ	45 Ⓢ	54 Ⓢ	46 Ⓢ	56 Ⓢ
	Y3	60 Ⓢ	52 Ⓢ	48 Ⓢ	58 Ⓢ	50 Ⓢ	59 Ⓢ
	W5	56 Ⓢ	47 Ⓢ	44 Ⓢ	54 Ⓢ	45 Ⓢ	55 Ⓢ
Weight with Arms	S0	60	51	48	57	49	58
	Y2	65 Ⓢ	56 Ⓢ	53 Ⓢ	62 Ⓢ	54 Ⓢ	64 Ⓢ
	Y3	68 Ⓢ	60 Ⓢ	56 Ⓢ	66 Ⓢ	58 Ⓢ	67 Ⓢ
	W5	64 Ⓢ	55 Ⓢ	52 Ⓢ	62 Ⓢ	53 Ⓢ	63 Ⓢ
Between Arms	A/V	17½-20	17½-20	17½-20	16¾-19¼	16¾-19¼	16¾-19¼
	F/P	20½	20½	20½	20½	20½	20½
COM		2.0	2.0	1.0	2.0	1.0	2.0
Weight Capacity		300 lbs	300 lbs	300 lbs	300 lbs	300 lbs	300 lbs

BIG & TALL & STOOL DIMENSIONS

MODEL		HLEUBT	HLWUBT	HLWMBT	HLTSU	HLTSM	HLTSP
Overall Width Armless		28½	28½	28½	28½	28½	28½
Overall Width with Arms	A/V	28½	28½	28½	28½	28½	28½
	F/P	28½	28½	28½	28½	28½	28½
Overall Depth		28½	28½	28½	28½	28½	28½
Overall Height	S0/S1	-	-	-	53	53	53
	Y4	49	49	49	-	-	-
Seat Width		23	23	23	19	19	19
Seat Depth	S0/S1	-	-	-	18⅝	18⅝	18⅝
	Y4	20¼	20¼	20¼	-	-	-
Usable Seat Depth	S0	-	-	-	17⅝	17⅝	17⅝
	S1	-	-	-	15¼-18¼	15¼-18¼	15¼-18¼
	Y4	17¾-19¼	17¾-19¼	17¼-18¾	-	-	-
Seat Height (mechanism)	S0/S1	-	-	-	22¾-32¾	22¾-32¾	22¾-32¾
	Y4	17½-22	17½-22	17½-22	-	-	-
Back Width		23¼	23½	22½	19¾	19¾	19¾
Back Height		28¼	25	25¾	22¾	22¾	22¾
Ship Weight Armless	S0	-	-	-	50	42	51
	S1	-	-	-	52	44	53
	Y4	57	57	57	-	-	-
Weight with Arms	S0	-	-	-	58	50	59
	S1	-	-	-	60	52	61
	Y4	65	65	65	-	-	-
Between Arms	A/V	20½-23	20½-23	20½-23	16¾-19¼	16¾-19¼	16¾-19¼
	F/P	23½	23½	23½	20½	20½	20½
COM		2.0	2.0	1.5	2.0	2.0	2.0
Weight Capacity		450 lbs	450 lbs	450 lbs	300 lbs	300 lbs	300 lbs

ENDORSE® Fabric Options

HON BRANDED FABRICS (For Seating)

GRADE 1	GRADE 2	GRADE 3	GRADE L
Attire	Appoint Seating	In Season	Denver Leather**
Centurion	Clyde	Purl	
Compass	Dotty	Silvertex™ Vinyl	
Contourett Polyurethane	Rush		
Dapper	Seed		
Hamilton	Spin Seating		
Inertia	Whisper Vinyl		
Optic			

For a complete list of fabrics, including partnership fabrics, go to hon.com/fabricsandfinishes.

Reference Fabric Color Combinations on pages 18-22 for color codes and legend on page 19 for lead times. For additional HON to Supply COM fabric grade pricing, go to honready.hon.com and click on the HON to Supply COM link.

*The following Endorse® models are not available in Beeline SMOMBEE: HLEU, HLWU, HLTU, HLTP, HLWUBT, HLEUBT, HLTSU, HLTSP.

**Denver Leather (SS) may not be available on every model within a specific series, please refer to the model's page for details.

 For Fire Code model, availability and ordering method, refer to pages 26-29. Available on select models, contact HON Customer Support for availability.



Icon Legend on page 15

HLEU

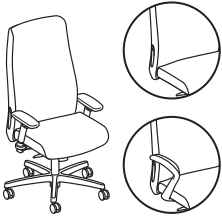

EXECUTIVE HIGH-BACK

Upholstered Back

- Pneumatic
- Swivel
- Synchro-tilt
- Tilt Tension
- Tilt Lock
- Integral Lumbar Support
- Optional Seat Glide

Functions: **A, E, J, K, L, W**
 (Function Key on pages 16-17)

! See page 69 for additional specifications and dimensions.

DIMENSIONS

Depth:	31½	Back Width:	21⅝
Width:	31½	Back Height:	29¾
Height:	47¾	Cube:	16.0
Seat Depth:	15¾	COM:	2.0
Seat Width:	19¾	Weight Rating:	300 lbs.

FABRIC PRICE CODES

1	\$757	8	\$1033
2	\$805	9	\$1069
3	\$853	10	\$1105
4	\$889	11	\$1141
5	\$925	12	\$1177
6	\$961	L	—
7	\$997		

HON Recommendation: HLEU.Y2.A.A.CU__SB - List Price \$897

HOW TO SPECIFY

Select Model Number	Select Control Type	Select Arm Type	Select Caster/Glide	Select Fabric	Select Base
S0 Limited Recline Synchro-Tilt	N Armless	A All-Surface Caster	See page 70	SB Standard Base	
Y2 Advanced Synchro-Tilt (+ \$65)	F Fixed Arms - Black (+ \$65)			PA Polished Aluminum (+ \$110)	
Y3 Synchro-Tilt with Independent Back Angle (+ \$105)	A Height and Width Adjustable Arms (+ \$75)				
W5 Weight-Activated (+ \$150)	V All-Adjustable Arms (includes pivot) (+ \$115)				
	P Fixed Arms - Polished (+ \$150)				
HLEU	Y2	A	A	CU10	SB



HLWU

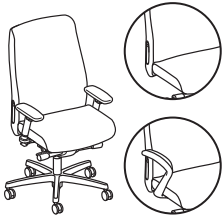

TASK MID-BACK

- Upholstered Back**
- Pneumatic
- Swivel
- Synchro-tilt
- Tilt Tension
- Tilt Lock
- Integral Lumbar Support
- Optional Seat Glide

Functions: **A, E, J, K, L, W**
(Function Key on pages 16-17)

See page 69 for additional specifications and dimensions.

DIMENSIONS

Depth:	28½	Back Width:	21¼
Width:	28½	Back Height:	25
Height:	44½	Cube:	10.8
Seat Depth:	15¾	COM:	2.0
Seat Width:	19¾	Weight Rating:	300 lbs.

FABRIC PRICE CODES

1	\$728	8	\$1004
2	\$776	9	\$1040
3	\$824	10	\$1076
4	\$860	11	\$1112
5	\$896	12	\$1148
6	\$932	L	—
7	\$968		

HLWM



TASK MID-BACK

- 4-Way Stretch Back**
- Pneumatic
- Swivel
- Synchro-tilt
- Tilt Tension
- Tilt Lock
- Integral Lumbar Support
- Optional Seat Glide

Functions: **A, E, J, K, L, W**
(Function Key on pages 16-17)

NOTES: For Mesh Back models, specify the 4-Way Stretch back option below. Headrest available on Mid-back 4-Way Stretch models only - Black only.

See page 69 for additional specifications and dimensions.

DIMENSIONS

Depth:	28½	Back Width:	19
Width:	28½	Back Height:	25
Height:	44½	Cube:	10.8
Seat Depth:	15¾	COM:	1.0
Seat Width:	19¾	Weight Rating:	300 lbs.

FABRIC PRICE CODES

1	\$728	8	\$866
2	\$752	9	\$884
3	\$776	10	\$902
4	\$794	11	\$920
5	\$812	12	\$938
6	\$830	L	\$928
7	\$848		

HON Recommendation: HLWM.Y2.A.H.IM.CU__SB.N - List Price \$868

HOW TO SPECIFY

Select Model Number	Select Control Type	Select Arm Type	Select Caster/Glide	Select Mesh Back	Select Fabric	Select Base	Select Headrest
S0 Limited Recline Synchro-Tilt	Y2 Advanced Synchro-Tilt (+ \$65)	N Armless	H Hard Caster	4-Way Stretch options	See page 70	SB Standard Base	N No Headrest
Y2 Advanced Synchro-Tilt (+ \$65)	Y3 Synchro-Tilt with Independent Back Angle (+ \$105)	F Fixed Arms - Black (+ \$65)	S Soft Caster (+ \$30)	IM Black		PA Polished Aluminum (+ \$110)	HR Headrest (+ \$80)
Y3 Synchro-Tilt with Independent Back Angle (+ \$105)	W5 Weight- Activated (+ \$150)	A Height and Width Adjustable Arms (+ \$75)	R Roll Control Caster (+ \$50)	IF Fog			<i>Black only. Specify for model HLWM only</i>
		V All-Adjustable Arms (includes pivot) (+ \$115)		IC Charcoal			
		P Fixed Arms - Polished (+ \$150)		IH Chai			
				IY Navy			
				<i>Specify the back for Mesh Back models only</i>			
HLWM	Y2	A	H	IM	CU10	SB	N



Icon Legend on page 15

HLTU

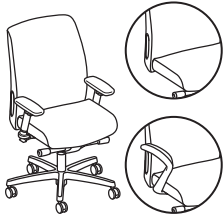

TASK LOW-BACK

- Upholstered Back**
- Pneumatic
- Swivel
- Synchro-tilt
- Tilt Tension
- Tilt Lock
- Integral Lumbar Support
- Optional Seat Glide

Functions: **A, E, J, K, L, W**
(Function Key on pages 16-17)

! Do not need to specify back option for Upholstered Back models. See page 69 for additional specifications and dimensions.

DIMENSIONS

Depth:	28½	Back Width:	19¾
Width:	28½	Back Height:	22¾
Height:	41¼	Cube:	10.8
Seat Depth:	15⅝	COM:	2.0
Seat Width:	18⅞	Weight Rating:	300 lbs.

FABRIC PRICE CODES

1	\$678	8	\$954
2	\$726	9	\$990
3	\$774	10	\$1026
4	\$810	11	\$1062
5	\$846	12	\$1098
6	\$882	L	—
7	\$918		

HLTM

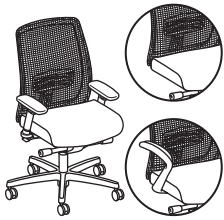

TASK LOW-BACK

- 4-Way Stretch Back**
- Pneumatic
- Swivel
- Synchro-tilt
- Tilt Tension
- Tilt Lock
- Integral Lumbar Support
- Optional Seat Glide

Functions: **A, E, J, K, L, W**
(Function Key on pages 16-17)

NOTES: For Mesh Back models, specify the 4-Way Stretch back option below.
! See page 69 for additional specifications and dimensions.

DIMENSIONS

Depth:	28½	Back Width:	17¾
Width:	28½	Back Height:	21¾
Height:	40¼	Cube:	10.8
Seat Depth:	15⅝	COM:	1.0
Seat Width:	18⅞	Weight Rating:	300 lbs.

FABRIC PRICE CODES

1	\$678	8	\$816
2	\$702	9	\$834
3	\$726	10	\$852
4	\$744	11	\$870
5	\$762	12	\$888
6	\$780	L	—
7	\$798		

HLTP

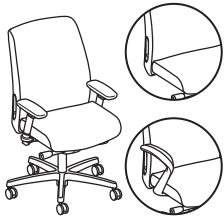

TASK LOW-BACK

- Plastic Outer Back**
- Pneumatic
- Swivel
- Synchro-tilt
- Tilt Tension
- Tilt Lock
- Integral Lumbar Support
- Optional Seat Glide

Functions: **A, E, J, K, L, W**
(Function Key on pages 16-17)

! Do not need to specify back option for Plastic Outer Back models. See page 69 for additional specifications and dimensions.

DIMENSIONS

Depth:	28½	Back Width:	19¾
Width:	28½	Back Height:	22¾
Height:	41¼	Cube:	10.8
Seat Depth:	15⅝	COM:	2.0
Seat Width:	18⅞	Weight Rating:	300 lbs.

FABRIC PRICE CODES

1	\$733	8	\$1009
2	\$781	9	\$1045
3	\$829	10	\$1081
4	\$865	11	\$1117
5	\$901	12	\$1153
6	\$937	L	—
7	\$973		

HON Recommendation: HLTM.Y2.A.H.IM.CU___.SB - List Price \$818

HOW TO SPECIFY

Select Model Number	Select Control Type	Select Arm Type	Select Caster/Glide	Select Mesh Back	Select Fabric	Select Base
HLTM	<ul style="list-style-type: none"> S0 Limited Recline Synchro-Tilt Y2 Advanced Synchro-Tilt (+ \$65) Y3 Synchro-Tilt with Independent Back Angle (+ \$105) W5 Weight-Activated (+ \$150) 	<ul style="list-style-type: none"> N Armless F Fixed Arms - Black (+ \$65) A Height and Width Adjustable Arms (+ \$75) V All-Adjustable Arms (includes pivot) (+ \$115) P Fixed Arms - Polished (+ \$150) 	<ul style="list-style-type: none"> H Hard Caster S Soft Caster (+ \$30) R Roll Control Caster (+ \$50) 	<ul style="list-style-type: none"> 4-Way Stretch options IM Black IF Fog IC Charcoal IH Chai IY Navy <p><i>Specify the back for Mesh Back models only</i></p>	See page 70	<ul style="list-style-type: none"> SB Standard Base PA Polished Aluminum (+ \$110)
HLTM	Y2	A	H	IM	CU10	SB



HLWUBT

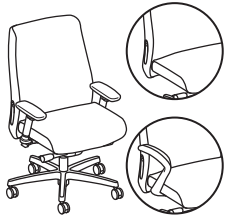

TASK MID-BACK

Big and Tall Upholstered Back

Pneumatic
Seat-glide
Swivel
Synchro-tilt
Tilt Lock
Side Tilt Tension
Integral Lumbar Support

Functions: **A, D, E, A-D, J, L, W**
(Function Key on pages 16-17)

❗ Do not need to specify back option for Upholstered Back models.

DIMENSIONS

Depth: 31½
Width: 31½
Height: 44⅝
Seat Depth: 21
Seat Width: 23
Back Width: 23½
Back Height: 25
Adjustable Arms Width: 21½-23¾
Fixed Arms Width: 24
Seat to Floor Height: 18-22¼
Usable Seat Depth: 17¾-19¼
Ship Weight: 65
Cube: 15.3
COM: 2.0
Weight Rating: 450 lbs.

FABRIC PRICE CODES

1	\$1210	8	\$1486
2	\$1258	9	\$1522
3	\$1306	10	\$1558
4	\$1342	11	\$1594
5	\$1378	12	\$1630
6	\$1414	L	—
7	\$1450		

HLWMBT



TASK MID-BACK

Big and Tall 4-Way Stretch Back

Pneumatic
Seat-glide
Swivel
Synchro-tilt
Tilt Lock
Side Tilt Tension
Integral Lumbar Support

Functions: **A, D, E, A-D, J, L, W**
(Function Key on pages 16-17)

NOTES: For Mesh Back models, specify the 4-Way Stretch back option below. Headrest available on Mid-back 4-Way Stretch models only - Black only.

DIMENSIONS

Depth: 31½
Width: 31½
Height: 44⅝
Seat Depth: 21
Seat Width: 23
Back Width: 22½
Back Height: 25¾
Adjustable Arms Width: 21½-23¾
Fixed Arms Width: 24
Seat to Floor Height: 18-22¼
Usable Seat Depth: 17¼-18¾
Ship Weight: 75
Cube: 15.3
COM: 1.5
Weight Rating: 450 lbs.

FABRIC PRICE CODES

1	\$1210	8	\$1417
2	\$1246	9	\$1444
3	\$1282	10	\$1471
4	\$1309	11	\$1498
5	\$1336	12	\$1525
6	\$1363	L	—
7	\$1390		

HLEUBT

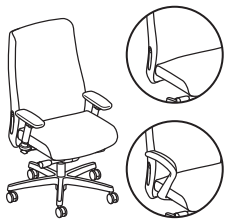

EXECUTIVE HIGH-BACK

Big and Tall Upholstered Back

Pneumatic
Seat-glide
Swivel
Synchro-tilt
Tilt Lock
Side Tilt Tension
Integral Lumbar Support

Functions: **A, D, E, A-D, J, L, W**
(Function Key on pages 16-17)

❗ Executive High-back Big and Tall models are available with an upholstered back only.

DIMENSIONS

Depth: 31½
Width: 31½
Height: 46⅝
Seat Depth: 21
Seat Width: 23
Back Width: 23¼
Back Height: 28¼
Adjustable Arms Width: 21½-23¾
Fixed Arms Width: 24
Seat to Floor Height: 18-22¼
Usable Seat Depth: 17¾-19¼
Ship Weight: 74
Cube: 16.0
COM: 2.0
Weight Rating: 450 lbs.

FABRIC PRICE CODES

1	\$1239	8	\$1515
2	\$1287	9	\$1551
3	\$1335	10	\$1587
4	\$1371	11	\$1623
5	\$1407	12	\$1659
6	\$1443	L	—
7	\$1479		

HON Recommendation: HLWMBT.Y4.A.A.IM.CU__SB.N - List Price \$1285

HOW TO SPECIFY

Select Model Number	Select Control Type	Select Arm Type	Select Caster/Glide	Select Mesh Back	Select Fabric	Select Base	Select Headrest
HLWMBT	Y4 <i>Y4 is the only control option for the Big and Tall models</i>	N Armless F Fixed Arms - Black (+ \$65) A Height and Width Adjustable Arms (+ \$75) V All-Adjustable Arms (includes pivot) (+ \$115) P Fixed Arms - Polished (+ \$150)	A All-surface Caster <i>All-surface caster available on Big and Tall models only</i>	4-Way Stretch option <i>Black only</i> IM Black <i>Specify the back for Mesh Back models only</i>	See page 70	SB Standard Base	N No Headrest HR Headrest (+ \$80) <i>Black only. Specify for model HLWMBT only</i>
HLWMBT	Y4	A	A	IM	CU10	SB	N



Icon Legend on page 15

HLTSU



STOOL

Upholstered Back

- Pneumatic
- Swivel
- Synchro-tilt
- Tilt Tension
- Tilt Lock
- Integral Lumbar Support

Functions: **A, E, J, K, L, W**
(Function Key on pages 16-17)

! Do not need to specify back option for Upholstered Back models. See page 69 for additional specifications and dimensions.

DIMENSIONS

Depth:	28½	Back Width:	19¾
Width:	28½	Back Height:	22¾
Height:	53½	Cube:	10.8
Seat Depth:	15⅝	COM:	2.0
Seat Width:	18⅞	Weight Rating:	300 lbs.

FABRIC PRICE CODES

1	\$808	8	\$1084
2	\$856	9	\$1120
3	\$904	10	\$1156
4	\$940	11	\$1192
5	\$976	12	\$1228
6	\$1012	L	—
7	\$1048		

HLTSM



STOOL

4-Way Stretch Back

- Pneumatic
- Swivel
- Synchro-tilt
- Tilt Tension
- Tilt Lock
- Integral Lumbar Support

Functions: **A, E, J, K, L, W**
(Function Key on pages 16-17)

NOTES: For Mesh Back models, specify the 4-Way Stretch back option below. See page 69 for additional specifications and dimensions.

DIMENSIONS

Depth:	28½	Back Width:	17¾
Width:	28½	Back Height:	21¾
Height:	52½	Cube:	10.8
Seat Depth:	15⅝	COM:	1.0
Seat Width:	18⅞	Weight Rating:	300 lbs.

FABRIC PRICE CODES

1	\$808	8	\$946
2	\$832	9	\$964
3	\$856	10	\$982
4	\$874	11	\$1000
5	\$892	12	\$1018
6	\$910	L	—
7	\$928		

HLTSP

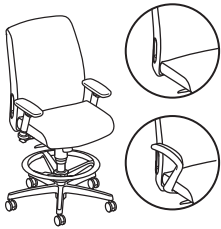

STOOL

Plastic Outer Back

- Pneumatic
- Swivel
- Synchro-tilt
- Tilt Tension
- Tilt Lock
- Integral Lumbar Support

Functions: **A, E, J, K, L, W**
(Function Key on pages 16-17)

! Do not need to specify back option for Outer Back models. See page 69 for additional specifications and dimensions.

DIMENSIONS

Depth:	28½	Back Width:	19¾
Width:	28½	Back Height:	22¾
Height:	52½	Cube:	10.8
Seat Depth:	15⅝	COM:	2.0
Seat Width:	18⅞	Weight Rating:	300 lbs.

FABRIC PRICE CODES

1	\$864	8	\$1140
2	\$912	9	\$1176
3	\$960	10	\$1212
4	\$996	11	\$1248
5	\$1032	12	\$1284
6	\$1068	L	—
7	\$1104		

HON Recommendation: HLTSM.S1.A.H.IM.CU__SB - List Price \$903

HOW TO SPECIFY

Select Model Number	Select Control Type	Select Arm Type	Select Caster/Glide	Select Mesh Back	Select Fabric	Select Base
<p>S0 Limited Recline Synchro-Tilt</p> <p>S1 Limited Recline Synchro-Tilt w/ Seat Slider (+ \$20)</p>	<p>N Armless</p> <p>F Fixed Arms - Black (+ \$65)</p> <p>A Height and Width Adjustable Arms (+ \$75)</p> <p>V All-Adjustable Arms (includes pivot) (+ \$115)</p> <p>P Fixed Arms - Polished (+ \$150)</p>	<p>H Hard Caster</p> <p>S Soft Caster (+ \$30)</p> <p>R Roll Control Caster (+ \$50)</p>	<p>4-Way Stretch options</p> <p>IM Black</p> <p>IF Fog</p> <p>IC Charcoal</p> <p>IH Chai</p> <p>IY Navy</p> <p><i>Specify the back for Mesh Back models only</i></p>	See page 70	<p>SB Standard Base</p> <p>PA Polished Aluminum (+ \$110)</p>	
HLTSM	S1	A	H	IM	CU10	SB



HL2DARM

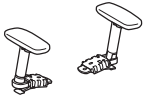

ADJUSTABLE T-ARMS

Height and Width
Functions: **S**
(Function Key on pages 16-17)

DIMENSIONS

Adjustable Arms Width: 16¾-19¼
Height from Seat: 7¼-11
Ship Weight: 8 **S**
Cube: 1.0

LIST PRICE

\$122

! Available in Black only. No need to specify.

HL4DARM



ALL-ADJUSTABLE ARMS

Height, Width, Depth and Pivot

DIMENSIONS

Adjustable Arms Width: 16¾-19¼
Height from Seat: 7¼-11
Ship Weight: 8 **S**
Cube: 1.0

LIST PRICE

\$164

! Available in Black only. No need to specify.

HI2FHA



FIXED HEIGHT ARMS

DIMENSIONS

Arm Width: 20
Height from Seat: 9½
Ship Weight: 7 **S**
Cube: 1.0

LIST PRICE

\$113

HIPAA

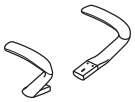

POLISHED ALUMINUM ARMS

Fixed Height

DIMENSIONS

Arm Width: 20
Height from Seat: 9½
Ship Weight: 10 **S**
Cube: 1.0

LIST PRICE

\$188

HLMSHHR



MESH HEADREST

DIMENSIONS

Mesh Width: 12
Mesh Height: 6
Ship Weight: 3 **S**
Cube: 1.0

QA DIMENSIONS

(Attachment Mechanism)

Width: 12
Depth: 6
Height: 12

LIST PRICE

\$136

! Available in Black Mesh (IM) only. For use with Mesh Mid-back models only.

HSCASTER

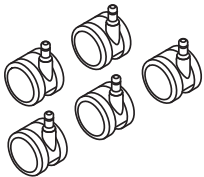

SET OF 5 SOFT CASTERS

DIMENSIONS

Size: 60mm
Ship Weight: 2 **S**
Cube: 0.1

LIST PRICE

\$50

! Available in Black finish only, no specification needed.

OPEN MARKET



HVL541



HIGH-BACK

Pneumatic
Swivel
Tilt
Tilt Tension
Tilt Lock
Adjustable Lumbar
Height-adjustable Arms

Functions: **A, E, F, K, L, Q, W**
(Function Key on pages 16-17)

DIMENSIONS

Depth:	28 ³ / ₈	Arm Width:	19 ³ / ₄
Width:	28 ³ / ₈	Seat to Floor Height:	17 ³ / ₄ -22 ¹ / ₂
Height:	43 ³ / ₈	Usable Seat Depth:	19 ¹ / ₄
Seat Depth:	19 ¹ / ₄	Ship Weight:	44 Ⓢ
Seat Width:	19 ⁵ / ₈	Cube:	4.0
Back Width:	16 ³ / ₄	Weight Rating:	250 lbs.
Back Height:	22 ³ / ₄		

PRICE CODE

Fabric **\$413**

NOTES: Comfortable and breathable mesh back. Black fabric seat. Black frame. Height-adjustable arms. **HON 5-Year Limited Warranty.**

HON Recommendation: HVL541.LH10 - List Price \$413

HOW TO SPECIFY

Select Model Number	Select Fabric
	LH10 Black Fabric
H V L 5 4 1 .	L H 1 0

EXPOSURE™ Mesh Chairs

OPEN MARKET



Icon Legend on page 15

HVL721



HIGH-BACK

Pneumatic
Swivel
Synchronized Tilt
Tilt Tension
Tilt Lock
Seat Glide Mechanism
Adjustable Lumbar
Height and Width Adjustable
Arms

Functions: **A, D, E, J, K, L, S, W**
(Function Key on pages 16-17)

NOTES: Available in Black SofThread™ Leather with Chrome accents. Available in Black fabric with Black accents. Comfortable and breathable mesh back. Adjustable seat glide mechanism. Height and width adjustable arms. Adjustable lumbar support. **HON 5-Year Limited Warranty.**

ⓘ LH10 Fabric only available with Black Frame/Base. SB11 Fabric only available with Chrome Frame/Base.

DIMENSIONS

Depth:	26¾	Arm Width:	16½-18¾
Width:	26½	Seat to Floor Height:	17½-22
Height:	42½	Usable Seat Depth:	17½-19½
Seat Depth:	17½-19½	Ship Weight:	40 Ⓢ
Seat Width:	19½	Cube:	5.5
Back Width:	18½	Weight Rating:	250 lbs.
Back Height:	24¼		

PRICE CODE

Fabric	\$569
Leather	\$616

HON Recommendation: HVL721.SB11 - List Price \$616

HOW TO SPECIFY

Select
Model Number

Select
Fabric

SB11 Black SofThread™ Leather
LH10 Black Fabric

H V L 7 2 1 .

S B 1 1

FLOCK®



Flock® Seating and Tables.

FLOCK®

Break away. Come together. Wherever people migrate within a space, Flock is designed to support their needs. With a full collection of modular and comfortable seating elements and coordinating collaborative tables that work seamlessly together, you can make the most of every square inch of your space. Modular lounge chairs and ottomans stand alone or combine to create large arrangements. Multi-purpose stools and chairs add comfort to open spaces. Collaborative tables that bring the whole group together. Flock helps people interact with each other, challenge one another, and receive the support they need.



CHAIR FEATURES

- Round and square lounge chairs are fully-upholstered.
- The contemporary aesthetic easily matches a variety of surroundings.
- Support everything from one-on-one conversations to large meetings.
- Choose from four leg options — standard, tapered round, tapered square or hard casters — or a 5-star base.
- Available in hundreds of quality HON fabrics.
- Warranted for users up to 300 lbs.

COLLABORATIVE TABLES

- Choose from round, square, rectangle or racetrack shaped table tops.
- Optional grommets neatly route cords.
- Bases available in disc, T-leg and X-leg styles.
- Choose bases with or without footings.
- Each base includes leveling glides that adjust in 1" increments.
- Tops are available in eight laminate finishes.
- Bases are available in either Textured Silver or Textured Charcoal finish.

FLOCK® Options

MODEL OPTIONS

HFLSC1
HFLSC1DF - Dual Fabric

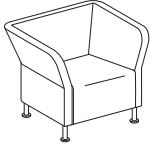

Lounge Chair
Square

HFLRC1
HFLRC1DF - Dual Fabric

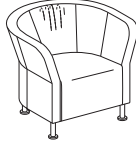

Lounge Chair
Round

HFLMC1
HFLMC1DF - Dual Fabric

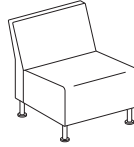

Modular Chair

HFLML1
HFLML1DF - Dual Fabric

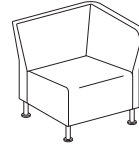

Modular
Left End

HFLMR1
HFLMR1DF - Dual Fabric

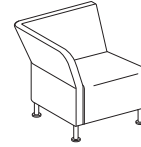

Modular
Right End

HFLCC1
HFLCC1DF - Dual Fabric

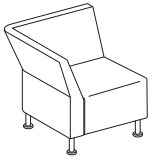

True Chair
Corner

HFLWI45
HFLWI45DF - Dual Fabric

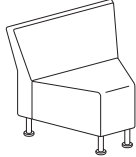

Wedge
Inside

HFLWO45
HFLWO45DF - Dual Fabric



Wedge
Outside

HFL450

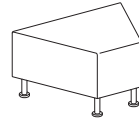

Wedge Ottoman

HFLSC1S
HFLSC1SDF - Dual Fabric

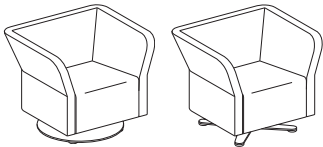

Square Lounge Chair
Swivel Base or X-Base

HFLRC1S
HFLRC1SDF - Dual Fabric

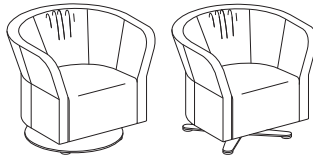

Round Lounge Chair
Swivel Base or X-Base

HFLMC1S
HFLMC1SDF - Dual Fabric

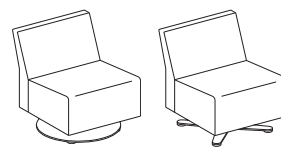

Modular Chair
Swivel Base or X-Base

LEG STYLE



CODE	DESCRIPTION	PRICE
L	Standard Leg	+\$0



TS	Tapered Square	+\$0
-----------	----------------	-------------



TR	Tapered Round	+\$0
-----------	---------------	-------------



H	Hard Casters	+\$0
----------	--------------	-------------

LEG COLOR

CODE	DESCRIPTION	PRICE
PR8	Textured Silver	+\$0
P7A	Textured Charcoal	+\$0
<i>*Specify PR8 & P7A for Standard Legs and Tapered Round & Tapered Square Legs only</i>		
T	Black Hard Caster	+\$0
<i>*Specify for Hard Caster option only</i>		

MODEL OPTIONS

HFLB2

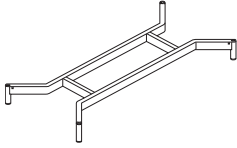

Two-Seat Base Frame

HFLB3

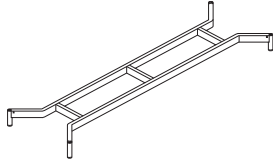

Three-Seat Base Frame

HTSSRD



Tapered Square
Leg - Shroud Pack

COMPATIBLE MODELS

HFLMC1
HFLMC1DF - Dual Fabric



Modular Chair

HFLML1
HFLML1DF - Dual Fabric

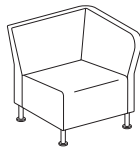

Modular
Left End

HFLMR1
HFLMR1DF - Dual Fabric

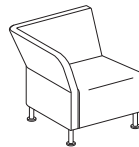

Modular
Right End

HFLCC1
HFLCC1DF - Dual Fabric

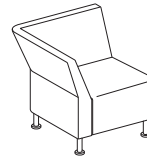

True Chair
Corner

HFLSO1

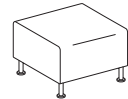

Square Ottoman

LEG STYLE



CODE	DESCRIPTION	PRICE
RS	Round Straight Leg	+\$0

Available in the following finishes:

PR8	Textured Silver
P7A	Textured Charcoal



TS	Tapered Square	+\$75
-----------	----------------	--------------

Available in the following finishes:

PR8	Textured Silver
P7A	Textured Charcoal

FLOCK® Fabric Options

HON BRANDED FABRICS

GRADE 1	GRADE 2	GRADE 3	GRADE L
Attire	Appoint Seating	In Season	Denver Leather*
Centurion	Clyde	Purl	
Compass	Dotty	Silvertex™ Vinyl	
Contourett Polyurethane	Rush		
Dapper	Seed		
Hamilton	Spin Seating		
Inertia	Whisper Vinyl		
Optic			

For a complete list of fabrics, including partnership fabrics, go to hon.com/fabricsandfinishes.

Flock® chair model HFLRC1 has fabric limitations, please see the Flock® seating pages 83-92 for details.

Reference Fabric Color Combinations on pages 18-22 for color codes and legend on page 19 for lead times.

*Denver Leather (SS) may not be available on every model within a specific series, please refer to the model's page for details.

⚡ For Fire Code model, availability and ordering method, refer to pages 26-29. Available on select models, contact HON Customer Support for availability.

⚠ Due to the inherent characteristics of upholstery materials, the seat of Flock® may become more relaxed to show wrinkles over time.

FLOCK® ROUND LOUNGE HFLRC1/DF HON BRANDED FABRICS

GRADE 1	GRADE 2	GRADE 3	GRADE L
Centurion	Appoint Seating	In Season	Denver Leather**
Compass	Clyde	Purl	
Contourett Polyurethane	Rush	Silvertex™ Vinyl	
Dapper	Seed*		
Hamilton	Spin Seating*		
Inertia	Whisper Vinyl		
Optic			

For a complete list of fabrics, including partnership fabrics, go to hon.com/fabricsandfinishes.

Reference Fabric Color Combinations on pages 18-22 for color codes and legend on page 19 for lead times.

*Available on seat only.

**Denver Leather (SS) may not be available on every model within a specific series, please refer to the model's page for details.

⚡ For Fire Code model, availability and ordering method, refer to pages 26-29. Available on select models, contact HON Customer Support for availability.

⚠ Due to the inherent characteristics of upholstery materials, the seat of Flock® may become more relaxed to show wrinkles over time.



HFLSC1

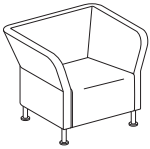

LOUNGE CHAIR

Square

DIMENSIONS

Depth:	28½	Arm Width:	27½
Width:	34¼	Seat to Floor Height:	17
Height:	28	Usable Seat Depth:	20½
Seat Depth:	20½	Ship Weight:	79
Seat Width:	21½	Cube:	21.9
Back Width:	21½	COM:	5.0
Back Height:	18½	Weight Rating:	300 lbs.

FABRIC PRICE CODES

1	\$1770	8	\$2391
2	\$1878	9	\$2472
3	\$1986	10	\$2553
4	\$2067	11	\$2634
5	\$2148	12	\$2715
6	\$2229	L	\$2670
7	\$2310		

ⓘ Leg options – Standard Leg (L), Tapered Square (TS) and Tapered Round (TR) are available in Textured Silver (PR8) and Textured Charcoal (P7A) only. Hard Casters (H) are available on Black (T) only.

HFLRC1

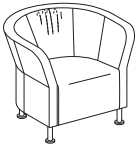

LOUNGE CHAIR

Round

DIMENSIONS

Depth:	29	Arm Width:	27½
Width:	33½	Seat to Floor Height:	17
Height:	28	Usable Seat Depth:	20½
Seat Depth:	20½	Ship Weight:	57
Seat Width:	20½	Cube:	21.9
Back Width:	20½	Weight Rating:	300 lbs.
Back Height:	18½		

FABRIC PRICE CODES

1	\$1849	8	\$2401
2	\$1945	9	\$2473
3	\$2041	10	\$2545
4	\$2113	11	\$2617
5	\$2185	12	\$2689
6	\$2257	L	\$2649
7	\$2329		

Due to the inherent design of the Round Lounge chair, material gathers will be present in the back.

ⓘ Round Lounge models HFLRC1 / HFLRCIDF are offered in select fabrics; for availability, please see the Fabric Matrix on page 82. Also approved in limited Partnership Fabrics. Leg options – Standard Leg (L), Tapered Square (TS) and Tapered Round (TR) are available in Textured Silver (PR8) and Textured Charcoal (P7A) only. Hard Casters (H) are available on Black (T) only.
 ⓘ Customer's Own Material (COM) is not available on Flock® model HFLRC1.

HON Recommendation: HFLSC1.TS.PNS__PR8 - List Price \$1878

HOW TO SPECIFY

<p>Select Model Number</p> <div style="border: 1px solid black; padding: 5px; display: flex; gap: 5px; margin-top: 10px;"> HFLSC1 </div>	<p>Select Leg Option</p> <p>L Standard Leg TS Tapered Square TR Tapered Round H Hard Casters</p> <div style="border: 1px solid black; padding: 5px; display: flex; gap: 5px; margin-top: 10px;"> TS </div>	<p>Select Fabric</p> <p>See page 82</p> <div style="border: 1px solid black; padding: 5px; display: flex; gap: 5px; margin-top: 10px;"> PNS007 </div>	<p>Select Leg Color</p> <p>PR8 Textured Silver P7A Textured Charcoal</p> <p><i>Specify for Standard, Tapered Round and Tapered Square legs only</i></p> <p>T Black Hard Caster <i>Specify for Hard Caster option only</i></p> <div style="border: 1px solid black; padding: 5px; display: flex; gap: 5px; margin-top: 10px;"> PR8 </div>
---	--	--	--



HFLMC1



MODULAR CHAIR

DIMENSIONS

Depth:	28½	Seat to Floor Height:	17
Width:	25	Usable Seat Depth:	20½
Height:	28	Ship Weight:	54
Seat Depth:	20½	Cube:	21.9
Seat Width:	25	COM:	3.0
Back Width:	25	Weight Rating:	300 lbs.
Back Height:	18½		

FABRIC PRICE CODES

1	\$1309	8	\$1723
2	\$1381	9	\$1777
3	\$1453	10	\$1831
4	\$1507	11	\$1885
5	\$1561	12	\$1939
6	\$1615	L	\$1909
7	\$1669		

! Leg options – Standard Leg (L), Tapered Square (TS) and Tapered Round (TR) are available in Textured Silver (PR8) and Textured Charcoal (P7A) only. Hard Casters (H) are available on Black (T) only.

HFLML1

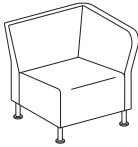

MODULAR

Left End

DIMENSIONS

Depth:	28½	Seat to Floor Height:	17
Width:	28½	Usable Seat Depth:	20½
Height:	28	Ship Weight:	72
Seat Depth:	20½	Cube:	21.9
Seat Width:	22¼	COM:	4.0
Back Width:	22¼	Weight Rating:	300 lbs.
Back Height:	18½		

FABRIC PRICE CODES

1	\$1530	8	\$2082
2	\$1626	9	\$2154
3	\$1722	10	\$2226
4	\$1794	11	\$2298
5	\$1866	12	\$2370
6	\$1938	L	\$2330
7	\$2010		

! Leg options – Standard Leg (L), Tapered Square (TS) and Tapered Round (TR) are available in Textured Silver (PR8) and Textured Charcoal (P7A) only. Hard Casters (H) are available on Black (T) only.

HFLMR1



MODULAR

Right End

DIMENSIONS

Depth:	28½	Seat to Floor Height:	17
Width:	28½	Usable Seat Depth:	20½
Height:	28	Ship Weight:	72
Seat Depth:	20½	Cube:	21.9
Seat Width:	22¼	COM:	4.0
Back Width:	22¼	Weight Rating:	300 lbs.
Back Height:	18½		

FABRIC PRICE CODES

1	\$1530	8	\$2082
2	\$1626	9	\$2154
3	\$1722	10	\$2226
4	\$1794	11	\$2298
5	\$1866	12	\$2370
6	\$1938	L	\$2330
7	\$2010		

! Leg options – Standard Leg (L), Tapered Square (TS) and Tapered Round (TR) are available in Textured Silver (PR8) and Textured Charcoal (P7A) only. Hard Casters (H) are available on Black (T) only.

HON Recommendation: HFLMC1.TS.PNS___.PR8 - List Price \$1381

HOW TO SPECIFY

<p>Select Model Number</p> <p>H F L M C 1 .</p>	<p>Select Leg Option</p> <p>L Standard Leg TS Tapered Square TR Tapered Round H Hard Casters</p> <p>T S .</p>	<p>Select Fabric</p> <p>See page 82</p> <p>P N S 0 0 7 .</p>	<p>Select Leg Color</p> <p>PR8 Textured Silver P7A Textured Charcoal</p> <p><i>Specify for Standard, Tapered Round and Tapered Square legs only</i></p> <p>T Black Hard Caster <i>Specify for Hard Caster option only</i></p> <p>P R 8</p>
--	---	---	---



HFLCC1

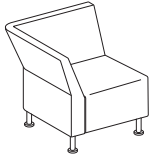

TRUE CORNER CHAIR

DIMENSIONS

Depth:	28½	Seat to Floor Height:	17
Width:	28½	Usable Seat Depth:	20½
Height:	28	Ship Weight:	60
Seat Depth:	20½	Cube:	21.9
Seat Width:	20½	COM:	4.0
Back Width:	22¼	Weight Rating:	300 lbs.
Back Height:	18½		

FABRIC PRICE CODES

1	\$1537	8	\$2321
2	\$1633	9	\$2445
3	\$1729	10	\$2569
4	\$1825	11	\$2693
5	\$1949	12	\$2817
6	\$2073	L	\$2337
7	\$2197		

ⓘ Leg options – Standard Leg (L), Tapered Square (TS) and Tapered Round (TR) are available in Textured Silver (PR8) and Textured Charcoal (P7A) only.

HFLWI45

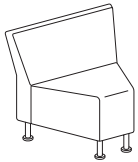

INSIDE WEDGE

DIMENSIONS

Depth:	26¼	Seat to Floor Height:	17
Width:	31½	Usable Seat Depth:	19
Height:	28	Ship Weight:	45
Seat Depth:	19½	Cube:	21.9
Seat Width:	25¾	COM:	3.0
Back Width:	31½	Weight Rating:	300 lbs.
Back Height:	18½		

FABRIC PRICE CODES

1	\$1522	8	\$2306
2	\$1618	9	\$2430
3	\$1714	10	\$2554
4	\$1810	11	\$2678
5	\$1934	12	\$2802
6	\$2058	L	\$2322
7	\$2182		

ⓘ Leg options – Standard Leg (L), Tapered Square (TS) and Tapered Round (TR) are available in Textured Silver (PR8) and Textured Charcoal (P7A) only.

HFLWO45



OUTSIDE WEDGE

DIMENSIONS

Depth:	26¼	Seat to Floor Height:	17
Width:	32	Usable Seat Depth:	19
Height:	28	Ship Weight:	35
Seat Depth:	19½	Cube:	21.9
Seat Width:	32	COM:	3.0
Back Width:	16¼	Weight Rating:	300 lbs.
Back Height:	18½		

FABRIC PRICE CODES

1	\$1522	8	\$2306
2	\$1618	9	\$2430
3	\$1714	10	\$2554
4	\$1810	11	\$2678
5	\$1934	12	\$2802
6	\$2058	L	\$2322
7	\$2182		

ⓘ Leg options – Standard Leg (L), Tapered Square (TS) and Tapered Round (TR) are available in Textured Silver (PR8) and Textured Charcoal (P7A) only.

HON Recommendation: HFLCC1.TS.PNS___.PR8 - List Price \$1537

HOW TO SPECIFY

<p>Select Model Number</p> <p>HFLCC1</p>	<p>Select Leg Option</p> <p>L Standard Leg TS Tapered Square TR Tapered Round</p> <p>TS</p>	<p>Select Fabric</p> <p>See page 82</p> <p>PNS007</p>	<p>Select Leg Color</p> <p>PR8 Textured Silver P7A Textured Charcoal</p> <p><i>Specify for Standard, Tapered Round and Tapered Square legs only</i></p> <p>PR8</p>
---	--	--	--



HFL450

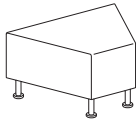

WEDGE OTTOMAN

DIMENSIONS

Depth:	23½	Usable Seat Depth:	23½
Width:	32	Ship Weight:	33
Height:	17	Cube:	12.6
Seat Depth:	23½	COM:	2.0
Seat Width:	32	Weight Rating:	300 lbs.
Seat to Floor Height:	17		

FABRIC PRICE CODES

1	\$752	8	\$1144
2	\$800	9	\$1206
3	\$848	10	\$1268
4	\$896	11	\$1330
5	\$958	12	\$1392
6	\$1020	L	\$1152
7	\$1082		

! Leg options – Standard Leg (L), Tapered Square (TS) and Tapered Round (TR) are available in Textured Silver (PR8) and Textured Charcoal (P7A) only.

HFLS01

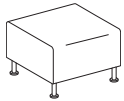

OTTOMAN

Square

DIMENSIONS

Depth:	25	Ship Weight:	30.0
Width:	25	Cube:	7.5
Height:	17	COM:	2.0
Seat Depth:	25	Weight Rating:	300 lbs.
Seat Width:	25		

FABRIC PRICE CODES

1	\$757	8	\$1033
2	\$805	9	\$1069
3	\$853	10	\$1105
4	\$889	11	\$1141
5	\$925	12	\$1177
6	\$961	L	\$1157
7	\$997		

- ! Leg options – Standard Leg (L), Tapered Square (TS) and Tapered Round (TR) are available in Textured Silver (PR8) and Textured Charcoal (P7A) only. Hard Casters (H) are available on Black (T) only.
- ! While the top surface of the ottoman is flat, modular models (pages 84-85 and 89-91) have a slight angle to their seats. Therefore, there will not be alignment between these units when placed side-by-side.

HFLGANG



GANGING BRACKET

For Flock® Modular Seating Models

- Can be used for in-line ganging ONLY
- Use bracket set to connect two models. Do not connect more than four models.
- No specification required for bracket

DIMENSIONS

Ship Weight:	0.5
Cube:	0.1

LIST PRICE

\$34

HON Recommendation: HFLS01.TS.PNS__PR8 - List Price \$805

HOW TO SPECIFY

<p>Select Model Number</p> <div style="border: 1px solid black; padding: 5px; margin-top: 10px;"> H F L S 0 1 </div>	<p>Select Leg Option</p> <p>L Standard Leg TS Tapered Square TR Tapered Round H Hard Casters</p> <div style="border: 1px solid black; padding: 5px; margin-top: 10px;"> T S </div>	<p>Select Fabric</p> <p>See page 82</p> <div style="border: 1px solid black; padding: 5px; margin-top: 10px;"> P N S 0 0 7 </div>	<p>Select Leg Color</p> <p>PR8 Textured Silver P7A Textured Charcoal</p> <p><i>Specify for Standard, Tapered Round and Tapered Square legs only</i></p> <p>T Black Hard Caster <i>Specify for Hard Caster option only</i></p> <div style="border: 1px solid black; padding: 5px; margin-top: 10px;"> P R 8 </div>
---	--	--	--



HFLSC1S

SQUARE LOUNGE CHAIR W/ SWIVEL BASE

DIMENSIONS

Depth:	28 ⁹ / ₁₆	Arm Width:	27 ¹ / ₂
Width:	34 ⁵ / ₃₂	Seat to Floor Height:	17
Height:	28	Usable Seat Depth:	20 ¹ / ₂
Seat Depth:	20 ¹⁷ / ₃₂	Ship Weight (X-base):	116
Seat Width:	21 ¹ / ₂	Ship Weight (Round base):	148
Back Width:	21 ¹ / ₂	Cube:	21.9
Back Height:	18 ¹ / ₂	COM:	5.0
		Weight Rating:	300 lbs.

FABRIC PRICE CODES

1	\$2301	8	\$2922
2	\$2409	9	\$3003
3	\$2517	10	\$3084
4	\$2598	11	\$3165
5	\$2679	12	\$3246
6	\$2760	L	\$3201
7	\$2841		



X-Base

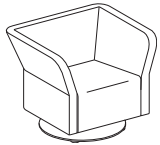

Disc Base

HFLRC1S

ROUND LOUNGE CHAIR W/ SWIVEL BASE

DIMENSIONS

Depth:	29 ¹ / ₁₆	Arm Width:	27 ¹ / ₂
Width:	33 ⁵ / ₃₂	Seat to Floor Height:	17
Height:	28	Usable Seat Depth:	20 ¹ / ₂
Seat Depth:	20 ¹ / ₂	Ship Weight (X-base):	94
Seat Width:	20 ¹ / ₂	Ship Weight (Round base):	126
Back Width:	20 ¹ / ₂	Cube:	21.9
Back Height:	18 ¹ / ₂	Weight Rating:	300 lbs.

FABRIC PRICE CODES

1	\$2387	8	\$2939
2	\$2483	9	\$3011
3	\$2579	10	\$3083
4	\$2651	11	\$3155
5	\$2723	12	\$3227
6	\$2795	L	\$3187
7	\$2867		

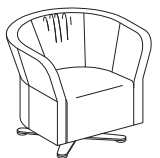

X-Base

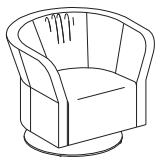

Disc Base

- ! Round Lounge model HFLRC1S is offered in select fabrics; for availability please see Fabric matrix on page 82. Also approved in limited Partnership Fabrics. Base options are available in Textured Silver (PR8) and Textured Charcoal (P7A) only.
- ! Customer's Own Material (COM) is not available on HFLRC1S.

HFLMC1S

MODULAR CHAIR W/ SWIVEL BASE

DIMENSIONS

Depth:	28 ¹ / ₂	Seat to Floor Height:	17
Width:	25	Usable Seat Depth:	20 ¹ / ₂
Height:	28	Ship Weight (X-base):	91
Seat Depth:	20 ¹ / ₂	Ship Weight (Round base):	123
Seat Width:	25	Cube:	21.9
Back Width:	25	COM:	3.0
Back Height:	18 ¹ / ₂	Weight Rating:	300 lbs.

FABRIC PRICE CODES

1	\$1711	8	\$2125
2	\$1783	9	\$2179
3	\$1855	10	\$2233
4	\$1909	11	\$2287
5	\$1963	12	\$2341
6	\$2017	L	\$2311
7	\$2071		



X-Base

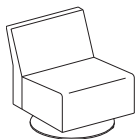

Disc Base

HON Recommendation: HFLMC1S.X.PNS__PR8 - List Price \$1711

HOW TO SPECIFY

Select Model Number H F L M C 1 S	Select Swivel Option X X Base D Disc Base X	Select Fabric See page 82 P N S 0 0 7	Select Base Color PR8 Textured Silver P7A Textured Charcoal P R 8
---	---	--	---

FLOCK® Dual Fabric Collaborative

GSA SIN 33721



Icon Legend on page 15

HFLSC1DF

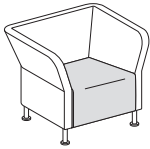

LOUNGE CHAIR

Dual Fabric
Square

DIMENSIONS

Depth:	28½	Arm Width:	27½
Width:	34¼	Seat to Floor Height:	17
Height:	28	Usable Seat Depth:	20½
Seat Depth:	20½	Ship Weight:	48
Seat Width:	21½	Cube:	27.0
Back Width:	21½	COM:	See page 101
Back Height:	18½	Weight Rating:	300 lbs.

FABRIC PRICE CODES

1	\$1847	
<i>Add to Base Price Above</i>		
	Back	Seat
2	\$80	\$28
3	\$160	\$56
4	\$220	\$77
5	\$280	\$98
6	\$340	\$119
7	\$400	\$140
8	\$460	\$161
9	\$519	\$183
10	\$579	\$204
11	\$639	\$225
12	\$699	\$246
L	\$666	\$234

For dual fabric models, start with the base price, then add the additional amount for the back and seat from the corresponding matrix to determine the final list price. Choose any combination of fabric grades for the back and seat.

Example: HFLSC1DF base price (\$1847) + Grade 2 back fabric (add \$80) + Grade 4 seat fabric (add \$77) = Total \$2004 List
 HFLSC1DF base price (\$1847) + Grade 5 back fabric (add \$280) + Grade 3 seat fabric (add \$56) = Total \$2183 List

HFLRC1DF

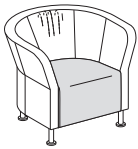

LOUNGE CHAIR

Dual Fabric
Round

DIMENSIONS

Depth:	29	Arm Width:	27½
Width:	33½	Seat to Floor Height:	17
Height:	28	Usable Seat Depth:	20½
Seat Depth:	20½	Ship Weight:	39
Seat Width:	20½	Cube:	27.0
Back Width:	20½	Weight Rating:	300 lbs.
Back Height:	18½		

FABRIC PRICE CODES

1	\$1926	
<i>Add to Base Price Above</i>		
	Back	Seat
2	\$71	\$25
3	\$142	\$50
4	\$195	\$69
5	\$249	\$87
6	\$302	\$106
7	\$355	\$125
8	\$408	\$144
9	\$462	\$162
10	\$515	\$181
11	\$568	\$200
12	\$622	\$218
L	\$592	\$208

NOTES: Due to the inherent design of the Round Lounge chair, material gathers will be present in the back.
 ⓘ Round Lounge models HFLRC1 / HFLRC1DF are offered in select fabrics; for availability, please see the Fabric Matrix on page 82. Also approved in limited Partnership Fabrics.

For dual fabric models, start with the base price, then add the additional amount for the back and seat from the corresponding matrix to determine the final list price. Choose any combination of fabric grades for the back and seat.

Example: HFLRC1DF base price (\$1926) + Grade 2 back fabric (add \$71) + Grade 4 seat fabric (add \$69) = Total \$2066 List
 HFLRC1DF base price (\$1926) + Grade 5 back fabric (add \$249) + Grade 3 seat fabric (add \$50) = Total \$2225 List

HON Recommendation: HFLSC1DF.TS.PNS__PNS__PR8 - List Price \$1955

HOW TO SPECIFY

<p>Select Model Number</p> <p>HFLSC1DF</p>	<p>Select Leg Option</p> <p>L Standard Leg TS Tapered Square TR Tapered Round H Hard Casters</p> <p>TS</p>	<p>Select Back Fabric</p> <p>See page 82</p> <p>PNS004</p>	<p>Select Seat Fabric</p> <p>See page 82</p> <p>PNS007</p>	<p>Select Leg Color</p> <p>PR8 Textured Silver P7A Textured Charcoal</p> <p><i>Specify for Standard, Tapered Round and Tapered Square legs only</i></p> <p>T Black Hard Caster <i>Specify for Hard Caster option only</i></p> <p>PR8</p>
---	--	---	---	---



Dual Fabric Collaborative

HFLMC1DF

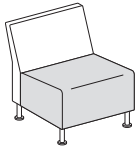

MODULAR CHAIR

Dual Fabric

DIMENSIONS

Depth:	28½	Seat to Floor Height:	17
Width:	25	Usable Seat Depth:	20½
Height:	28	Ship Weight:	52
Seat Depth:	20½	Cube:	24.0
Seat Width:	25	COM:	See page 101
Back Width:	25	Weight Rating:	300 lbs.
Back Height:	18½		

FABRIC PRICE CODES

1	\$1388	
<i>Add to Base Price Above</i>		
	Back	Seat
2	\$36	\$36
3	\$72	\$72
4	\$99	\$99
5	\$126	\$126
6	\$153	\$153
7	\$180	\$180
8	\$207	\$207
9	\$234	\$234
10	\$261	\$261
11	\$288	\$288
12	\$315	\$315
L	\$300	\$300

HFLML1DF

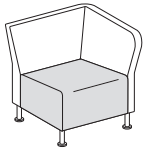

MODULAR LEFT END

Dual Fabric

DIMENSIONS

Depth:	28½	Seat to Floor Height:	17
Width:	28½	Usable Seat Depth:	20½
Height:	28	Ship Weight:	72
Seat Depth:	20½	Cube:	24.0
Seat Width:	22¼	COM:	See page 101
Back Width:	22¼	Weight Rating:	300 lbs.
Back Height:	18½		

FABRIC PRICE CODES

1	\$1608	
<i>Add to Base Price Above</i>		
	Back	Seat
2	\$71	\$25
3	\$142	\$50
4	\$195	\$69
5	\$249	\$87
6	\$302	\$106
7	\$355	\$125
8	\$408	\$144
9	\$462	\$162
10	\$515	\$181
11	\$568	\$200
12	\$622	\$218
L	\$592	\$208

HON Recommendation: HFLMC1DF.TS.PNS__PNS__PR8 - List Price \$1460

HOW TO SPECIFY

<p>Select Model Number</p>	<p>Select Leg Option</p> <p>L Standard Leg TS Tapered Square TR Tapered Round H Hard Casters</p>	<p>Select Back Fabric</p> <p>See page 82</p>	<p>Select Seat Fabric</p> <p>See page 82</p>	<p>Select Leg Color</p> <p>PR8 Textured Silver P7A Textured Charcoal</p> <p><i>Specify for Standard, Tapered Round and Tapered Square legs only</i></p> <p>T Black Hard Caster</p> <p><i>Specify for Hard Caster option only</i></p>
<p>HFLMC1DF</p>	<p>TS</p>	<p>PNS004</p>	<p>PNS007</p>	<p>PR8</p>

FLOCK® Dual Fabric Collaborative

GSA SIN 33721



Icon Legend on page 15

HFLMR1DF

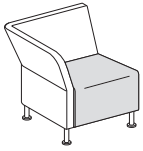

MODULAR RIGHT END

Dual Fabric

DIMENSIONS

Depth:	28½	Seat to Floor Height:	17
Width:	28½	Usable Seat Depth:	20½
Height:	28	Ship Weight:	72.0
Seat Depth:	20½	Cube:	24.0
Seat Width:	22¼	COM:	See page 101
Back Width:	22¼	Weight Rating:	300 lbs.
Back Height:	18½		

FABRIC PRICE CODES

1	\$1608	
	<i>Add to Base Price Above</i>	
	Back	Seat
2	\$71	\$25
3	\$142	\$50
4	\$195	\$69
5	\$249	\$87
6	\$302	\$106
7	\$355	\$125
8	\$408	\$144
9	\$462	\$162
10	\$515	\$181
11	\$568	\$200
12	\$622	\$218
L	\$592	\$208

HON Recommendation: HFLMR1DF.TS.PNS___.PNS___.PR8 - List Price \$1704

HOW TO SPECIFY

<p>Select Model Number</p>	<p>Select Leg Option</p> <p>L Standard Leg TS Tapered Square TR Tapered Round H Hard Casters</p>	<p>Select Back Fabric</p> <p>See page 82</p>	<p>Select Seat Fabric</p> <p>See page 82</p>	<p>Select Leg Color</p> <p>PR8 Textured Silver P7A Textured Charcoal</p> <p><i>Specify for Standard, Tapered Round and Tapered Square legs only</i></p> <p>T Black Hard Caster <i>Specify for Hard Caster option only</i></p>
<p>H F L M R 1 D F .</p>	<p>T S .</p>	<p>P N S 0 0 4 .</p>	<p>P N S 0 0 7 .</p>	<p>P R 8</p>



Dual Fabric Collaborative

HFLCC1DF

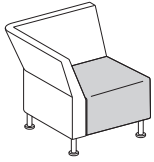

TRUE CORNER CHAIR

Dual Fabric

DIMENSIONS

Depth:	28½	Seat to Floor Height:	17
Width:	28½	Usable Seat Depth:	21
Height:	28	Ship Weight:	60
Seat Depth:	20½	Cube:	21.9
Seat Width:	20½	COM:	See page 101
Back Width:	22¼	Weight Rating:	300 lbs.
Back Height:	18½		

FABRIC PRICE CODES

1	\$1615	
	<i>Add to Base Price Above</i>	
	Back	Seat
2	\$48	\$48
3	\$96	\$96
4	\$144	\$144
5	\$206	\$206
6	\$268	\$268
7	\$330	\$330
8	\$392	\$392
9	\$454	\$454
10	\$516	\$516
11	\$578	\$578
12	\$640	\$640
L	\$400	\$400

! Leg options – Standard Leg (L), Tapered Square (TS) and Tapered Round (TR) are available in Textured Silver (PR8) and Textured Charcoal (P7A) only. Hard Casters (H) are available on Black (T) only.

HFLWI45DF

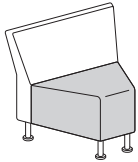

INSIDE WEDGE

Dual Fabric

DIMENSIONS

Depth:	26¼	Seat to Floor Height:	17
Width:	31½	Usable Seat Depth:	19
Height:	28	Ship Weight:	45
Seat Depth:	19½	Cube:	21.9
Seat Width:	25¾	COM:	See page 101
Back Width:	31½	Weight Rating:	300 lbs.
Back Height:	18½		

FABRIC PRICE CODES

1	\$1599	
	<i>Add to Base Price Above</i>	
	Back	Seat
2	\$48	\$48
3	\$96	\$96
4	\$144	\$144
5	\$206	\$206
6	\$268	\$268
7	\$330	\$330
8	\$392	\$392
9	\$454	\$454
10	\$516	\$516
11	\$578	\$578
12	\$640	\$640
L	\$400	\$400

! Leg options – Standard Leg (L), Tapered Square (TS) and Tapered Round (TR) are available in Textured Silver (PR8) and Textured Charcoal (P7A) only. Hard Casters (H) are available on Black (T) only.

HFLWO45DF

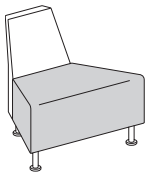

OUTSIDE WEDGE

Dual Fabric

DIMENSIONS

Depth:	26½	Seat to Floor Height:	17
Width:	32	Usable Seat Depth:	19
Height:	28	Ship Weight:	35
Seat Depth:	19½	Cube:	21.9
Seat Width:	32	COM:	See page 101
Back Width:	16¼	Weight Rating:	300 lbs.
Back Height:	18½		

FABRIC PRICE CODES

1	\$1599	
	<i>Add to Base Price Above</i>	
	Back	Seat
2	\$48	\$48
3	\$96	\$96
4	\$144	\$144
5	\$206	\$206
6	\$268	\$268
7	\$330	\$330
8	\$392	\$392
9	\$454	\$454
10	\$516	\$516
11	\$578	\$578
12	\$640	\$640
L	\$400	\$400

! Leg options – Standard Leg (L), Tapered Square (TS) and Tapered Round (TR) are available in Textured Silver (PR8) and Textured Charcoal (P7A) only. Hard Casters (H) are available on Black (T) only.

HOW TO SPECIFY

HON Recommendation: HFLCC1DF.TS.PNS___.PNS___.PR8 - List Price \$1711

<p>Select Model Number</p> <p>HFLCC1DF.</p>	<p>Select Leg Option</p> <p>L Standard Leg TS Tapered Square TR Tapered Round H Hard Casters</p> <p>TS.</p>	<p>Select Back Fabric</p> <p>See page 82</p> <p>PNS004.</p>	<p>Select Seat Fabric</p> <p>See page 82</p> <p>PNS007.</p>	<p>Select Leg Color</p> <p>PR8 Textured Silver P7A Textured Charcoal</p> <p><i>Specify for Standard, Tapered Round and Tapered Square legs only</i></p> <p>T Black Hard Caster <i>Specify for Hard Caster option only</i></p> <p>PR8</p>
--	---	--	--	---

FLOCK® Dual Fabric Collaborative

GSA SIN 33721



Icon Legend on page 15

HFLSC1SDF

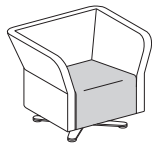

X-Base

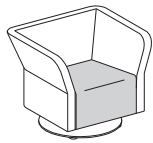

Disc Base

SQUARE LOUNGE CHAIR W/ SWIVEL BASE

Dual Fabric

DIMENSIONS

Depth:	28 ⁹ / ₁₆	Arm Width:	27 ¹ / ₂
Width:	34 ⁵ / ₃₂	Seat to Floor Height:	17
Height:	28	Usable Seat Depth:	20 ¹ / ₂
Seat Depth:	20 ¹⁷ / ₃₂	Ship Weight (X-base):	116
Seat Width:	21 ¹ / ₂	Ship Weight (Round base):	148
Back Width:	21 ¹ / ₂	Cube:	21.9
Back Height:	18 ¹ / ₂	COM:	See page 101
		Weight Rating:	300 lbs.

FABRIC PRICE CODES

1	\$2384	
	<i>Add to Base Price Above</i>	
	Back	Seat
2	\$80	\$28
3	\$160	\$56
4	\$220	\$77
5	\$280	\$98
6	\$340	\$119
7	\$400	\$140
8	\$460	\$161
9	\$519	\$183
10	\$579	\$204
11	\$639	\$225
12	\$699	\$246
L	\$666	\$234

HFLRC1SDF



X-Base

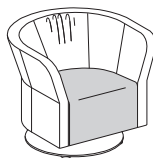

Disc Base

ROUND LOUNGE CHAIR W/ SWIVEL BASE

Dual Fabric

DIMENSIONS

Depth:	29 ¹ / ₁₆	Arm Width:	27 ¹ / ₂
Width:	33 ⁵ / ₃₂	Seat to Floor Height:	17
Height:	28	Usable Seat Depth:	20 ¹ / ₂
Seat Depth:	20 ¹ / ₂	Ship Weight (X-base):	94
Seat Width:	20 ¹ / ₂	Ship Weight (Round base):	126
Back Width:	20 ¹ / ₂	Cube:	21.9
Back Height:	18 ¹ / ₂	Weight Rating:	300 lbs.

FABRIC PRICE CODES

1	\$2469	
	<i>Add to Base Price Above</i>	
	Back	Seat
2	\$71	\$25
3	\$142	\$50
4	\$195	\$69
5	\$249	\$87
6	\$302	\$106
7	\$355	\$125
8	\$408	\$144
9	\$462	\$162
10	\$515	\$181
11	\$568	\$200
12	\$622	\$218
L	\$592	\$208

NOTES: Due to the inherent design of the Round Lounge chair, material gathers will be present in the back.

! Round Lounge model HFLRC1SDF is offered in select fabrics; for availability, please see the Fabric Matrix on page 82. Also approved in limited Partnership Fabrics.

For dual fabric models, start with the base price, then add the additional amount for the back and seat from the corresponding matrix to determine the final list price. Choose any combination of fabric grades for the back and seat.

Example: HFLRC1SDF base price (\$2469) + Grade 2 back fabric (add \$71) + Grade 4 seat fabric (add \$69) = Total \$2609 List

HFLMC1SDF



X-Base

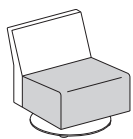

Disc Base

MODULAR CHAIR W/ SWIVEL BASE

Dual Fabric

DIMENSIONS

Depth:	28 ¹ / ₂	Seat to Floor Height:	17
Width:	25	Usable Seat Depth:	20 ¹ / ₂
Height:	28 ¹ / ₂	Ship Weight (X-base):	91
Seat Depth:	20 ¹ / ₂	Ship Weight (Round base):	123
Seat Width:	25	Cube:	21.9
Back Width:	25	COM:	See page 101
Back Height:	18 ¹ / ₂	Weight Rating:	300 lbs.

FABRIC PRICE CODES

1	\$1790	
	<i>Add to Base Price Above</i>	
	Back	Seat
2	\$36	\$36
3	\$72	\$72
4	\$99	\$99
5	\$126	\$126
6	\$153	\$153
7	\$180	\$180
8	\$207	\$207
9	\$234	\$234
10	\$261	\$261
11	\$288	\$288
12	\$315	\$315
L	\$300	\$300

HOW TO SPECIFY

HON Recommendation: HFLMC1SDF.X.PNS__PNS__PR8 - List Price \$1862

Select Model Number H F L M C 1 S D F	Select Swivel Option X X Base D Disc Base	Select Back Fabric See page 82	Select Seat Fabric See page 82	Select Base Color PR8 Textured Silver P7A Textured Charcoal
H F L M C 1 S D F	X	P N S 0 0 4	P N S 0 0 7	P R 8



FLOCK® Base Frames and Legs

	DESCRIPTION	MODEL	SHIP WEIGHT	CUBE	LIST PRICE
	Two-Seat Base Frame	HFLB2	25	5.9	\$400
	Three-Seat Base Frame	HFLB3	33	7.8	\$500

HOW TO SPECIFY

<p>Select Model Number</p>	<p>Select Leg Option</p> <p>RS Round Straight Leg TS Tapered Square Leg (+ \$75)</p> <p>Select Leg Color</p> <p>PR8 Textured Silver P7A Textured Charcoal</p>
<div style="border: 1px solid black; padding: 2px; display: inline-block;">H</div> <div style="border: 1px solid black; padding: 2px; display: inline-block;">F</div> <div style="border: 1px solid black; padding: 2px; display: inline-block;">L</div> <div style="border: 1px solid black; padding: 2px; display: inline-block;">B</div> <div style="border: 1px solid black; padding: 2px; display: inline-block;">2</div>	<div style="border: 1px solid black; padding: 2px; display: inline-block;">R</div> <div style="border: 1px solid black; padding: 2px; display: inline-block;">S</div> <div style="border: 1px solid black; padding: 2px; display: inline-block;">P</div> <div style="border: 1px solid black; padding: 2px; display: inline-block;">R</div> <div style="border: 1px solid black; padding: 2px; display: inline-block;">8</div>

	DESCRIPTION	MODEL	SHIP WEIGHT	CUBE	LIST PRICE
	Tapered Square Leg — Shroud Pack	HTSSRD	2	1.0	\$75

HOW TO SPECIFY

<p>Select Model Number</p>	<p>Select Leg Color</p> <p>PR8 Textured Silver P7A Textured Charcoal</p>
<div style="border: 1px solid black; padding: 2px; display: inline-block;">H</div> <div style="border: 1px solid black; padding: 2px; display: inline-block;">T</div> <div style="border: 1px solid black; padding: 2px; display: inline-block;">S</div> <div style="border: 1px solid black; padding: 2px; display: inline-block;">S</div> <div style="border: 1px solid black; padding: 2px; display: inline-block;">R</div> <div style="border: 1px solid black; padding: 2px; display: inline-block;">D</div>	<div style="border: 1px solid black; padding: 2px; display: inline-block;">P</div> <div style="border: 1px solid black; padding: 2px; display: inline-block;">R</div> <div style="border: 1px solid black; padding: 2px; display: inline-block;">8</div>

FLOCK® Options

MODEL OPTIONS

HFSS7

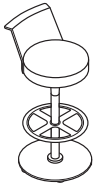

Stool

HFCG6
HFCG6DF - Dual Fabric



Guest Chair
Casual

HFCL2
HFCL2DF - Dual Fabric



Wide Lounge Chair
With 4-Star Base

HFLSC2
HFLSC2DF - Dual Fabric



Square Chair
With 4-Star Base

HFSS74L
HFSS74LDF - Dual Fabric



Stool
4-Leg

SHELL COLOR

CODE	DESCRIPTION	PRICE
LA	Lava	+\$0
ON	Onyx	+\$0
PT	Platinum	+\$0
SD	Shadow	+\$0

**Available for model HFSS7 only*

FRAME

CODE	DESCRIPTION	PRICE
4S	4-Star Base*	+\$0
<i>*Available for models HFCL2 and HFLSC2 only</i>		
<i>Available in the following finishes:</i>		
PR8	Textured Silver	
P7A	Textured Charcoal	

HON BRANDED FABRICS

GRADE 1	GRADE 2	GRADE 3	GRADE L
Attire	Appoint Seating	In Season	Denver Leather*
Centurion	Clyde	Purl	
Compass	Dotty	Silvertex™ Vinyl	
Contourett Polyurethane	Rush		
Dapper	Seed		
Hamilton	Spin Seating		
Inertia	Whisper Vinyl		
Optic			

For a complete list of fabrics, including partnership fabrics, go to hon.com/fabricsandfinishes.

Flock® chair models HFLRC1 and HFLRC1DF have fabric limitations, please see the Flock® seating pages 83-92 and 96 for details. Reference Fabric Color Combinations on pages 18-22 for color codes and legend on page 19 for lead times.

*Denver Leather (SS) may not be available on every model within a specific series, please refer to the model's page for details.

FLOCK® SQUARE CHAIR HFLSC2/DF HON BRANDED FABRICS

GRADE 1	GRADE 2	GRADE 3	GRADE L
Centurion	Appoint Seating	In Season	Denver Leather**
Compass	Clyde	Purl	
Contourett Polyurethane	Rush	Silvertex™ Vinyl	
Dapper	Seed*		
Hamilton	Spin Seating*		
Inertia	Whisper Vinyl		
Optic*			

For a complete list of fabrics, including partnership fabrics, go to hon.com/fabricsandfinishes.

Flock® chair model HFLSC2/DF has fabric limitations, please see the Flock® seating pages 97-99 for details.

*Available on seat only.

**Denver Leather (SS) may not be available on every model within a specific series, please refer to the model's page for details.

Reference Fabric Color Combinations on pages 18-22 for color codes and legend on page 19 for lead times.



HFSS7

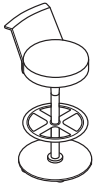

STOOL

DIMENSIONS

Depth:	18	Seat to Floor Height:	31
Width:	18	Usable Seat Depth:	15 ³ / ₄
Height:	39 ¹ / ₈	Ship Weight:	57
Seat Depth:	15 ³ / ₄	Cube:	11.0
Seat Width:	15 ³ / ₄	Weight Rating:	300 lbs.
Back Width:	15 ³ / ₄		
Back Height:	8		

FABRIC PRICE CODES

1	\$806	8	\$1013
2	\$842	9	\$1040
3	\$878	10	\$1067
4	\$905	11	\$1094
5	\$932	12	\$1121
6	\$959	L	—
7	\$986		

! Customer's Own Material (COM) is not available on Flock® models HFLRC1 or HFSS7.

HON Recommendation: HFSS7.PT.PNS__PR8 - List Price \$842

HOW TO SPECIFY

Select Model Number HFSS7	Select Shell Color LA Lava ON Onyx PT Platinum SD Shadow PT	Select Fabric See page 95 PNS007	Select Frame PR8 Textured Silver P7A Textured Charcoal PR8
---	---	---	--

HFSG6



GUEST CHAIR

Casual

DIMENSIONS

Depth:	23 ⁵ / ₁₆	Seat to Floor Height:	18 ¹ / ₄
Width:	19	Usable Seat Depth:	16 ⁷ / ₈
Height:	32 ¹ / ₂	Ship Weight:	24
Seat Depth:	16 ⁷ / ₈	Cube:	10.4
Seat Width:	19	COM:	1.8
Back Width:	19	Weight Rating:	300 lbs.
Back Height:	14 ¹ / ₄		

FABRIC PRICE CODES

1	\$605	8	\$881
2	\$653	9	\$917
3	\$701	10	\$953
4	\$737	11	\$989
5	\$773	12	\$1025
6	\$809	L	\$1005
7	\$845		

HFSS74L



STOOL

4-Leg

DIMENSIONS

Depth:	21 ¹ / ₈	Seat to Floor Height:	30
Width:	18	Usable Seat Depth:	15 ⁷ / ₈
Height:	40 ⁷ / ₈	Ship Weight:	35
Seat Depth:	15 ⁷ / ₈	Cube:	21.8
Seat Width:	18	COM:	1.9
Back Width:	18	Weight Rating:	300 lbs.
Back Height:	10 ⁷ / ₈		

FABRIC PRICE CODES

1	\$753	8	\$1029
2	\$801	9	\$1065
3	\$849	10	\$1101
4	\$885	11	\$1137
5	\$921	12	\$1173
6	\$957	L	\$1153
7	\$993		

HON Recommendation: HFSS74L.PNS__PR8 - List Price \$801

HOW TO SPECIFY

Select Model Number HFSS74L	Select Fabric See page 95 PNS007	Select Frame PR8 Textured Silver PR8
---	---	---



HFCL2



WIDE LOUNGE CHAIR

with 4-Star Base

DIMENSIONS

Depth:	27½	Seat to Floor Height:	17
Width:	26¾	Usable Seat Depth:	19
Height:	32¼	Ship Weight:	53
Seat Width:	26	Cube:	25.1
Back Width:	25½	COM:	2.5
Back Height:	19½	Weight Rating:	300 lbs.

FABRIC PRICE CODES

1	\$1050	8	\$1464
2	\$1122	9	\$1518
3	\$1194	10	\$1572
4	\$1248	11	\$1626
5	\$1302	12	\$1680
6	\$1356	L	\$1650
7	\$1410		

HFLSC2



SQUARE CHAIR

with 4-Star Base

DIMENSIONS

Depth:	26½	Seat to Floor Height:	18
Width:	27½	Usable Seat Depth:	18¾
Height:	32¼	Ship Weight:	46
Seat Width:	17½	Cube:	25.1
Back Width:	16	COM:	3.0
Back Height:	17¾	Weight Rating:	300 lbs.

FABRIC PRICE CODES

1	\$1500	8	\$1914
2	\$1572	9	\$1968
3	\$1644	10	\$2022
4	\$1698	11	\$2076
5	\$1752	12	\$2130
6	\$1806	L	\$2100
7	\$1860		

HON Recommendation: HFLSC2.PNS__4SPR8 - List Price \$1500

HOW TO SPECIFY

<p>Select Model Number</p> <p style="border: 1px solid black; display: inline-block; padding: 2px;">H F L S C 2</p>	<p>Select Fabric</p> <p>See page 95</p> <p style="border: 1px solid black; display: inline-block; padding: 2px;">P N S 0 0 7</p>	<p>Select Base Option</p> <p>4S 4-Star Base</p> <p>Select Base Color</p> <p>PR8 Textured Silver</p> <p>P7A Textured Charcoal</p> <p style="border: 1px solid black; display: inline-block; padding: 2px;">4 S P R 8</p>
---	--	---



HFSG6DF



CASUAL GUEST CHAIR

Dual Fabric

DIMENSIONS

Depth:	23 ⁵ / ₁₆	Seat to Floor Height:	18 ¹ / ₄
Width:	19	Usable Seat Depth:	16 ⁷ / ₈
Height:	32 ¹ / ₂	Ship Weight:	24
Seat Depth:	16 ⁷ / ₈	Cube:	10.4
Seat Width:	19	COM:	See page 101
Back Width:	19	Weight Rating:	300 lbs.
Back Height:	14 ¹ / ₄		

FABRIC PRICE CODES

1 \$685

Add to Base Price Above

	Back	Seat
2	\$24	\$24
3	\$48	\$48
4	\$66	\$66
5	\$84	\$84
6	\$102	\$102
7	\$120	\$120
8	\$138	\$138
9	\$156	\$156
10	\$174	\$174
11	\$192	\$192
12	\$210	\$210
L	\$200	\$200

HFSS74LDF



4-LEG STOOL

Dual Fabric

DIMENSIONS

Depth:	21 ¹ / ₈	Seat to Floor Height:	30
Width:	18	Usable Seat Depth:	15 ¹ / ₈
Height:	40 ⁷ / ₈	Ship Weight:	35
Seat Depth:	15 ⁷ / ₈	Cube:	21.8
Seat Width:	18	COM:	See page 101
Back Width:	18	Weight Rating:	300 lbs.
Back Height:	10 ⁷ / ₈		

FABRIC PRICE CODES

1 \$834

Add to Base Price Above

	Back	Seat
2	\$24	\$24
3	\$48	\$48
4	\$66	\$66
5	\$84	\$84
6	\$102	\$102
7	\$120	\$120
8	\$138	\$138
9	\$156	\$156
10	\$174	\$174
11	\$192	\$192
12	\$210	\$210
L	\$200	\$200

HON Recommendation: HFSS74LDF.PNS___.PNS___.PR8 - List Price \$882

HOW TO SPECIFY

<p>Select Model Number</p> <p>HFSS74LDF</p>	<p>Select Back Fabric</p> <p>See page 95</p> <p>PNS004</p>	<p>Select Seat Fabric</p> <p>See page 95</p> <p>PNS007</p>	<p>Select Frame</p> <p>PR8 Textured Silver (only)</p> <p>PR8</p>
---	--	--	--



Dual Fabric Collaborative

HFCL2DF



WIDE LOUNGE CHAIR

with 4-Star Base

DIMENSIONS

Depth:	27½	Seat to Floor Height:	17
Width:	26¾	Usable Seat Depth:	19
Height:	32¼	Ship Weight:	53
Seat Width:	26	Cube:	25.1
Back Width:	25½	COM:	See page 101
Back Height:	19½	Weight Rating:	300 lbs.

FABRIC PRICE CODES

1	\$1125	
<i>Add to Base Price Above</i>		
	Back	Seat
2	\$36	\$36
3	\$108	\$108
4	\$162	\$162
5	\$216	\$216
6	\$270	\$270
7	\$324	\$324
8	\$378	\$378
9	\$432	\$432
10	\$486	\$486
11	\$540	\$540
12	\$594	\$594
L	\$300	\$300

HFLSC2DF



SQUARE CHAIR

with 4-Star Base

DIMENSIONS

Depth:	26½	Seat to Floor Height:	18
Width:	27½	Usable Seat Depth:	18¾
Height:	32¼	Ship Weight:	46
Seat Width:	17½	Cube:	25.1
Back Width:	16	COM:	See page 101
Back Height:	17¾	Weight Rating:	300 lbs.

FABRIC PRICE CODES

1	\$1575	
<i>Add to Base Price Above</i>		
	Back	Seat
2	\$48	\$24
3	\$120	\$96
4	\$174	\$150
5	\$228	\$204
6	\$282	\$258
7	\$336	\$312
8	\$390	\$366
9	\$444	\$420
10	\$498	\$474
11	\$552	\$528
12	\$606	\$582
L	\$400	\$200

HON Recommendation: HFLSC2DF.PURL__PURL__4SPR8 - List Price \$1791

HOW TO SPECIFY

<p>Select Model Number</p>	<p>Select Back Fabric See page 95</p>	<p>Select Seat Fabric See page 95</p>	<p>Select Base Option 4S 4-Star Base</p> <p>Select Base Color PR8 Textured Silver P7A Textured Charcoal</p>
<p>H F L S C 2 D F .</p>	<p>P U R L 1 2 .</p>	<p>P U R L 1 2 .</p>	<p>4 S P R 8</p>

MODEL OPTIONS

HFLCO1
HFLCO1DF - Dual Fabric

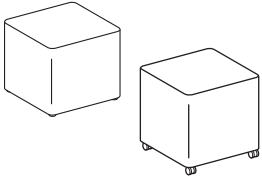

Mini Cube

HFLYO1
HFLYO1DF - Dual Fabric

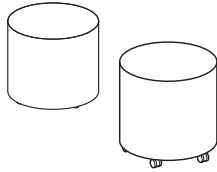

Mini Cylinder

CASTER/ GLIDES

CODE	DESCRIPTION	PRICE
A	Active Base*	+\$75
<i>*Available on models HFLYO1 and HFLYO1DF only</i>		
H	Hard Caster	+\$0
HG	Hidden Glide	+\$0
LPR8	Textured Silver Disc Glide	+\$45
LP7A	Textured Charcoal Disc Glide	+\$45

DUAL FABRIC COM YARDAGE

Due to fabric pattern nesting and potential reduction of fabric yield, some dual fabric models may require more total yardage than standard models.

MODEL	BACK COM	SEAT COM
HFLMC1DF	1.6	1.5
HFLML1DF	2.9	1.4
HFLMR1DF	2.9	1.4
HFCG6DF	1.8	1.9
HFSS74LDF	1.4	1.9
HFLWI45DF	2.3	1.4
HFLWO45DF	1.0	1.4
HFLCC1DF	2.3	1.4
HFLSC1SDF	3.6	1.4
HFLMC1SDF	1.6	1.5
HFCL2DF	1.5	2.0
HFLSC2DF	2.5	3.0
TOP		SIDE
HFLCO1DF	0.7	1.2
HFLYO1DF	0.7	1.2

HON BRANDED FABRICS

GRADE 1

Attire
Centurion
Compass
Contourett Polyurethane
Dapper
Hamilton
Inertia
Optic

GRADE 2

Appoint Seating
Clyde
Dotty
Rush
Spin Seating
Whisper Vinyl

GRADE 3

In Season
Purl
Silvertex™ Vinyl

GRADE L

Denver Leather

For a complete list of fabrics, including partnership fabrics, go to hon.com/fabricsandfinishes.

Reference Fabric Color Combinations on pages 18-22 for color codes and legend on page 19 for lead times.

 For Fire Code model, availability and ordering method, refer to pages 26-29. Available on select models, contact HON Customer Support for availability.

FLOCK® Mini Cube and Cylinders

GSA SIN 33721



Icon Legend on page 15

HFLCO1

MINI CUBE

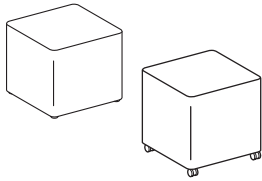

DIMENSIONS

Depth:	18½	Seat to Floor Height:	17
Width:	18½	Usable Seat Depth:	18½
Height:	17	Ship Weight:	15 Ⓢ
Seat Depth:	18½	Cube:	5.0
Seat Width:	18½	COM:	1.8
		Weight Rating:	300 lbs.

FABRIC PRICE CODES

1	\$457	8	\$664
2	\$493	9	\$691
3	\$529	10	\$718
4	\$556	11	\$745
5	\$583	12	\$772
6	\$610	L	\$757
7	\$637		

HFLY01

MINI CYLINDER

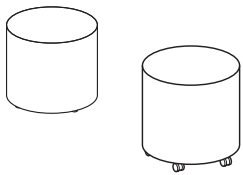

DIMENSIONS

Depth:	18½	Seat to Floor Height:	17
Width:	18½	Usable Seat Depth:	18½
Height:	17	Ship Weight:	13 Ⓢ
Seat Depth:	18½	Cube:	5.0
Seat Width:	18½	COM:	1.8
		Weight Rating:	300 lbs.

FABRIC PRICE CODES

1	\$454	8	\$661
2	\$490	9	\$688
3	\$526	10	\$715
4	\$553	11	\$742
5	\$580	12	\$769
6	\$607	L	\$754
7	\$634		

HON Recommendation: HFLY01.LPR8.PNS__ - List Price \$535

HOW TO SPECIFY

Select Model Number

HFLY01 .

Select Base

- A** Active Base* (+ \$75)
- *Available on model HFLY01 only*
- H** Caster
- HG** Hidden Glide
- LPR8** Textured Silver Disc Glide (+ \$45)
- LP7A** Textured Charcoal Disc Glide (+ \$45)

LPR8 .

Select Fabric

See page 101

PNS007



Dual Fabric Mini Cube and Cylinder

HFLCO1DF

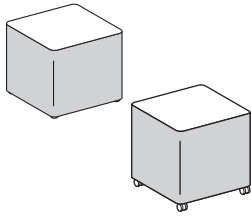

MINI CUBE

Dual Fabric

DIMENSIONS

Depth:	18½	Seat to Floor Height:	17
Width:	18½	Usable Seat Depth:	18½
Height:	17	Ship Weight:	15 S
Seat Depth:	18½	Cube:	5.0
Seat Width:	18½	COM:	See page 101
		Weight Rating:	300 lbs.

FABRIC PRICE CODES

1	\$536	
<i>Add to Base Price Above</i>		
	Top	Sides
2	\$11	\$25
3	\$22	\$50
4	\$30	\$69
5	\$38	\$88
6	\$46	\$107
7	\$54	\$126
8	\$62	\$145
9	\$70	\$164
10	\$78	\$183
11	\$86	\$202
12	\$95	\$221
L	\$90	\$210

HFLY01DF

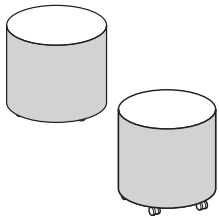

MINI CYLINDER

Dual Fabric

DIMENSIONS

Depth:	18½	Seat to Floor Height:	17
Width:	18½	Usable Seat Depth:	18½
Height:	17	Ship Weight:	13 S
Seat Depth:	18½	Cube:	5.0
Seat Width:	18½	COM:	See page 101
		Weight Rating:	300 lbs.

FABRIC PRICE CODES

1	\$531	
<i>Add to Base Price Above</i>		
	Top	Sides
2	\$11	\$25
3	\$22	\$50
4	\$30	\$69
5	\$38	\$88
6	\$46	\$107
7	\$54	\$126
8	\$62	\$145
9	\$70	\$164
10	\$78	\$183
11	\$86	\$202
12	\$95	\$221
L	\$90	\$210

HON Recommendation: HFLCO1DF.HG.PNS___.PNS__ - List Price \$572

HOW TO SPECIFY

<p>Select Model Number</p>	<p>Select Base</p> <p>A Active Base* (+ \$75) *Available on model HFLY01DF only</p> <p>H Caster HG Hidden Glide LPR8 Textured Silver Disc Glide (+ \$45) LP7A Textured Charcoal Disc Glide (+ \$45)</p>	<p>Select Top Fabric</p> <p>See page 101</p>	<p>Select Side Fabric</p> <p>See page 101</p>
<p>H F L C O 1 D F .</p>	<p>H G .</p>	<p>P N S 0 0 7 .</p>	<p>P N S 0 0 4</p>

FLOCK® Table Options

LAMINATE

TOPS/L1 LAMINATES CODES

Woodgrain

- ◆ Bourbon Cherry H
- ◆ Cognac COGN
- ◆ Florence Walnut LFW1
- ◆ Harvest C
- ◆ Kingswood Walnut LK11
- ◆ Mahogany N
- ◆ Mocha MOCH
- ◆ Natural Maple D
- ◆ Pinnacle PINC
- ◆ Shaker Cherry F

Solid

- ◆ Black P
- ◆ Charcoal S
- ◆ Designer White LDW1
- ◆ Loft LOFT
- ◆ Whitestone K4

Patterned

- ◆ Sheer Mesh*** A5
- ◆ Silver Mesh*** B9
- ◆ Steel Mesh*** A9
- ◆ Canyon Zephyr*** K9
- ◆ Desert Zephyr*** K8
- ◆ Shadow Zephyr*** K1

TOPS/L2 LAMINATES CODES

Woodgrain

- ◆ Lowell Ash LLA1
- ◆ Natural Recon LNR1
- ◆ Phantom Ecu LPE1
- ◆ Portico Teak LPT1
- ◆ Skyline Walnut LSW1

PAINT

PAINT** CODES

- P1
- ◆ Textured Charcoal P7A
- P2
- ◆ Textured Silver PR8

EDGE BAND

EDGE BAND* CODES

- ◆ Black P
- ◆ Bourbon Cherry H
- ◆ Charcoal S
- ◆ Cognac COGN
- ◆ Designer White DW
- ◆ Florence Walnut FW
- ◆ Greige R
- ◆ Harvest C
- ◆ Kingswood Walnut KI
- ◆ Loft LOFT
- ◆ Lowell Ash DL
- ◆ Mahogany N
- ◆ Mocha MOCH
- ◆ Muslin T
- ◆ Natural Maple D
- ◆ Natural Recon NR
- ◆ Phantom Ecu PE
- ◆ Pinnacle PINC
- ◆ Platinum K
- ◆ Portico Teak DP
- ◆ Shadow SHDW
- ◆ Shaker Cherry F
- ◆ Skyline Walnut SW

Recommended Edgeband Color Selection:

Laminate		Edgeband	
Bourbon Cherry	H	Bourbon Cherry	H
Cognac	COGN	Cognac	COGN
Florence Walnut	LFW1	Florence Walnut	FW
Harvest	C	Harvest	C
Kingswood Walnut	LK11	Kingswood Walnut	KI
Mahogany	N	Mahogany	N
Mocha	MOCH	Mocha	MOCH
Natural Maple	D	Natural Maple	D
Pinnacle	PINC	Pinnacle	PINC
Shaker Cherry	F	Shaker Cherry	F
Black	P	Black	P
Charcoal	S	Charcoal	S
Designer White	LDW1	Designer White	DW
Whitestone	K4	Muslin	T
Sheer Mesh	A5	Muslin	T
Silver Mesh	B9	Loft	LOFT
Steel Mesh	A9	Charcoal	S
Canyon Zephyr	K9	Greige	R
Desert Zephyr	K8	Greige	R
Shadow Zephyr	K1	Loft	LOFT
Lowell Ash	LLA1	Lowell Ash	DL
Natural Recon	LNR1	Natural Recon	NR
Phantom Ecu	LPE1	Phantom Ecu	PE
Portico Teak	LPT1	Portico Teak	DP
Skyline Walnut	LSW1	Skyline Walnut	SW
Loft	LOFT	Loft	LOFT

* Edge detail color can be different from top color on laminate tops and tablets.

** Applies to all models — includes bases and legs.

*** Patterned Laminates not available on Flock® Cubes and Mini Tops.

◆◆◆ For lead time information see page 19.

TOP SHAPES

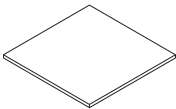

Square



Round

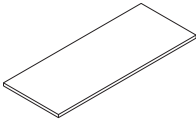

Rectangle



Racetrack

TABLE BASES

For 18" Tables

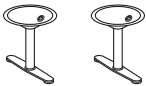

T-Leg Style

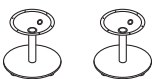

Disc Style

For 29½" Tables



X-Style



Disc Style

For 41" Standing Height Tables



X-Style

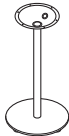

Disc Style

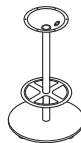

Disc Style with Footring

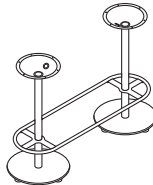

Disc Style with Footring

TABLES



Personal Table



Tablet Accessory

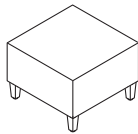

Cube Table



Cylinder Table

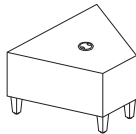

Wedge Table

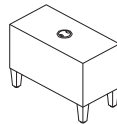

Rectangle Table

FLOCK® Table Features

GROMMET MATRIX — ALL TABLES/TOPS

TOP WIDTH	NO GROMMET	1-3" ROUND GROMMET CENTERED	2-3" ROUND GROMMET LEFT & RIGHT
SIF OPTION CODE	N	G	G
24" Cube	YES	YES	N/A
26" Cylinder	YES	YES	N/A
18" Personal	N/A	N/A	N/A
30" Square/Round	YES	YES	N/A
36" Square/Round	YES	YES	N/A
60" Rectangle/Racetrack	YES	N/A	YES
72" Rectangle/Racetrack	YES	N/A	YES
84" Rectangle/Racetrack	YES	N/A	YES
96" Rectangle/Racetrack	YES	N/A	YES

3" ROUND GROMMET LOCATIONS

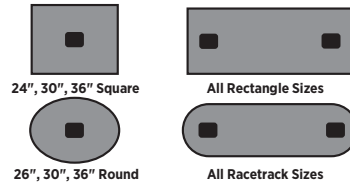

NOTES: 3" round grommet color will need to be specified for tops. Grommet will coordinate with paint color specified for cube/cylinder tables. Charcoal grommets will be used with Textured Charcoal paint and Platinum Metallic grommets will be used with Textured Silver paint.

Grommet options can be used in conjunction with accessory ports on cube/cylinder tables.

Grommet models HGRMTAC, HGRMTDATA and HGRMTUSB2 on page 113 can also be used with Flock® tables.

ACCESSORY PORT LOCATIONS

Only applies to models HFTLS24 and HFTLD26.

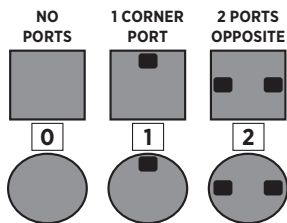

NOTES:

Port location 1 allows for one tablet accessory — see model on page 112.

Port location 2 allows for two tablet accessories — see model on page 112.



Collaborative Laminate Table Tops

	DESCRIPTION	MODEL	SHIP WEIGHT	CUBE	LIST PRICE BY LAMINATE GRADE	
					L1	L2
	Laminate Table Tops					
	36" Square Top	HFTLS36	45	1.2	\$428	\$448
	30" Square Top	HFTLS30	32	1.0	\$380	\$400
	36" Round Top	HFTLD36	35	1.2	\$428	\$448
	30" Round Top	HFTLD30	25	1.0	\$380	\$400
	96"W x 33"D Rectangle Top	HFTLC3396	105	2.9	\$757	\$792
	84"W x 33"D Rectangle Top	HFTLC3384	90	2.5	\$647	\$677
	72"W x 33"D Rectangle Top	HFTLC3372	78	2.2	\$541	\$566
	60"W x 24"D Rectangle Top	HFTLC2460	47	1.3	\$396	\$411
	96"W x 33"D Racetrack Top	HFTLA3396	101	2.9	\$757	\$792
	84"W x 33"D Racetrack Top	HFTLA3384	83	2.5	\$647	\$677
	72"W x 33"D Racetrack Top	HFTLA3372	70	2.2	\$541	\$566
	60"W x 24"D Racetrack Top	HFTLA2460	43	1.3	\$396	\$411

NOTES: Choose from Square, Round, Rectangle or Racetrack shaped table tops. Grommet models HGRMTAC, HGRMTDATA and HGRMTUSB2 on page 113 can also be used with Flock® tables. Specify table tops with or without grommets. See page 106. Specify bases separately, see pages 108-109. Rectangle and Racetrack tops come with 2 grommet cutouts if specified with Round grommet. For a complete line of compatible Flock® collaborative seating solutions, please see pages 83-103 of the seating section.

HON Recommendation: HFTLS36.G.N.C - List Price \$428

HOW TO SPECIFY





<p>Select Model Number</p>	<p>Select Edge Detail</p> <p>G 2MM Edge</p>	<p>Select Grommet Option</p> <p>N No Grommet G Round Grommet (+ \$15 per grommet cutout) See page 106 for Grommet placement</p>	<p>Select Laminate Color</p> <p>See page 104</p>
<p>Select Edge Color</p> <p>See page 104</p>	<p>Select Grommet Color</p> <p>S Charcoal T1 Platinum Metallic</p>	<p>H F T L S 3 6 . G . N . C</p>	

FLOCK® Collaborative Table Bases

GSA SIN 33721

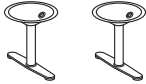
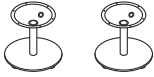

Icon Legend on page 15

	DESCRIPTION	MODEL	SHIP WEIGHT	CUBE	LIST PRICE
	Base T-Leg Style — For 18”H Tables For 60”W x 24”D Rectangle or Racetrack Table Tops • Two bases shipped in separate cartons.	HFTB17N	40	6.0	\$952
	Base Disc Style — For 18”H Tables • Use with 60”W x 24”D Racetrack or Rectangle table tops only. • Two bases shipped in separate cartons.	HFDB17N	74	6.0	\$1046
	Base Disc Style — For 18”H Tables For 30” and 36” Round or Square Table Tops	HFDB17B	37	3.0	\$512
	Base X-Style — For 29½”H Tables For 30” Round or Square Table Tops For 36” Round or Square Table Tops Use with 33”D x 72”W x 84”W and 96”W Rectangle or Racetrack Table Tops • Two bases shipped in separate cartons	HFXB29A HFXB29B HFXB29AN	40 53 80	16.1 16.1 32.2	\$596 \$630 \$1192
	Base X-Style — For 18”H Tables For 30” and 36” Round or Square Table Tops	HFXB17B	37	3.0	\$512
	Base Disc Style — For 29½”H Tables For 30” Round or Square Table Tops For 36” Round or Square Table Tops Use with 33”D x 72”W x 84”W and 96”W Rectangle or Racetrack Table Tops • Two bases shipped in separate cartons	HFDB29A HFDB29B HFDB29AN	40 56 80	16.1 16.1 32.2	\$596 \$630 \$1192

NOTES: Flock® Bases available in Disc, T-Leg and X styles. Specify bases for collaborative tables at 18”H, 29½”H or 41”H standing height. Choose from bases with or without footrings. Each base includes adjustable leveling glides. Leveling glides adjust approximately 1”.

HON Recommendation: HFXB29AN.P7A - List Price \$1192

HOW TO SPECIFY

<p>Select Model Number</p>	<p>Select Paint Color</p> <p>PR8 Textured Silver P7A Textured Charcoal</p>
<p>H F X B 2 9 A N .</p>	<p>P 7 A</p>

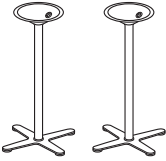
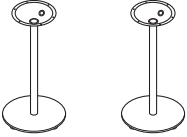
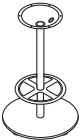

Collaborative Table Bases

	DESCRIPTION	MODEL	SHIP WEIGHT	CUBE	LIST PRICE
	Base X-Style — For 41”H Standing Height Tables • Use with 33”D x 72”W, 84”W and 96”W Rectangle or Racetrack Table Tops • Two bases shipped in separate cartons	HFXB42AN	84	36.4	\$1250
	Base X-Style — For 41”H Standing Height Tables For 30” Round or Square Table Tops For 36” Round or Square Table Tops	HFXB42A HFXB42B	42 55	18.2 16.1	\$625 \$660
	Base Disc Style — For 41”H Standing Height Tables • Use with 33”D x 72”W, 84”W and 96”W Rectangle or Racetrack table tops, when a Footring is not desired. • Two bases shipped in separate cartons.	HFDB42AN	92	19.0	\$1212
	Base Disc Style — For 41”H Standing Height Tables For 30” Round or Square Table Tops For 36” Round or Square Table Tops	HFDB42A HFDB42B	46 62	9.5 13.5	\$606 \$643
	Base Disc Style with Footring — For 41”H Standing Height Tables For 30” Round or Square Table Tops For 36” Round or Square Table Tops Use with 33”D x 72”W x 84”W and 96”W Rectangle or Racetrack Table Tops • Two bases shipped in separate cartons	HFDB42AF HFDB42BF HFDB42AFN	56 68 112	9.5 13.5 32.2	\$785 \$823 \$1570
	Base Disc Style with Footring — For 41”H Standing Height Tables For 33”D x 96”W Rectangle or Racetrack Table Tops For 33”D x 84”W Rectangle or Racetrack Table Tops For 33”D x 72”W Rectangle or Racetrack Table Tops	HFDB42AF96 HFDB42AF84 HFDB42AF72	121 123 125	19.7 19.8 19.9	\$1816 \$1756 \$1726
	NOTES: Includes two bases and a single oval footring that spans both tables. Two bases and footring shipped in three separate cartons.				

NOTES: Flock® Bases available in Disc, T-Leg and X styles. Specify bases for collaborative tables at 18”H, 29½”H or 41”H standing height. Choose from bases with or without footrings. Each base includes adjustable leveling glides. Leveling glides adjust approximately 1”.

HON Recommendation: HFXB42B.P7A - List Price \$660

HOW TO SPECIFY

Select Model Number H F X B 4 2 B	Select Paint Color PR8 Textured Silver P7A Textured Charcoal P 7 A
---	--

FLOCK® Collaborative Tables

GSA SIN 33721



Icon Legend on page 15



DESCRIPTION	MODEL	SHIP WEIGHT	CUBE	L1 LIST	L2 UPCHARGE
Laminate Personal Table 18" Dia. x 25"H	HFTPTL18	36	4.5	\$618	\$12

HON Recommendation: HFTPTL18.C.C.P7A - List Price \$618

HOW TO SPECIFY

<p>Select Model Number</p> <p>H F T P T L 1 8 .</p>	<p>Select Edge Detail/Color</p> <p>C .</p>	<p>Select Laminate Top Color</p> <p>See page 104</p> <p>C .</p>	<p>Select Base Paint Color</p> <p>PR8 Textured Silver P7A Textured Charcoal</p> <p>P 7 A</p>
--	---	--	---



FLOCK® Collaborative Tables

	DESCRIPTION	MODEL	SHIP WEIGHT	CUBE	L1 LIST	L2 UPCHARGE
	Laminate Collaborative Cube and Cylinder Tables 24" Laminate Cube Table — 24"W x 24"D x 17½"H 26" Laminate Cylinder Table — 26" Dia. x 17½"H	HFTLS24 HFTLD26	44 39	5.0 5.0	\$742 \$681	\$30 \$30
	NOTES: Accessory port quantity and configuration on tables should correspond to the accessories planned for the table. For grommet and port information, see page 106.					
	Laminate Wedge Table 22.17"W x 29.43"D x 17"H	HFTLW45	34	7.7	\$709	\$30
<i>Shown with Round Grommet</i>						
	Laminate Rectangle Table 24"W x 12"D x 17"H	HFTLR12	29	3.9	\$494	\$20
<i>Shown with Round Grommet</i>						

HON Recommendation: HFTLS24.N.O.N.TS.P7A - List Price \$742

HOW TO SPECIFY

Select Model Number H F T L S 2 4 .	Select Grommet Option See page 106 for Grommet placement N No Grommet G Round Grommet — centered (+ \$15)	Select Accessory Port Option See page 106 for Port placement 0 No Port 1 One Corner Port 2 Two Ports — Opposite (+ \$10 per port)	Select Laminate Top Color See page 104 N .	Select Leg Option L Standard Leg Leg Options TR Tapered Round Leg TS Tapered Square Leg	Select Leg Color PR8 Textured Silver P7A Textured Charcoal
---	---	---	---	--	---

FLOCK® Collaborative Tables

GSA SIN 33721



Icon Legend on page 15



DESCRIPTION	MODEL	SHIP WEIGHT	CUBE	L1 LIST	L2 UPCHARGE
Laminate Tablet Accessory 14" Dia. x 10"H from table top Use with Collaborative Cube and Cylinder tables for additional workspace. Attaches to tables through ports. Multiple port location options are available. Tablet pivots/swivels toward the user.	HFTTAL14	6	2.5	\$368	\$15

HON Recommendation: HFTTAL14.C.C.P7A - List Price \$368

HOW TO SPECIFY

<p>Select Model Number</p> <p>H F T T A L 1 4 .</p>	<p>Select Edge Detail/Color</p> <p>C .</p>	<p>Select Laminate Top Color</p> <p>See page 104</p> <p>C .</p>	<p>Select Paint Color</p> <p>PR8 Textured Silver P7A Textured Charcoal</p> <p>P 7 A</p>
--	---	--	--



HGRMTAC

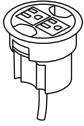

SIN 33721T

POWER HUB

3" Grommet Mount, 6' Cord

DIMENSIONS

Ship Weight: 1.3
Cube: 0.2

LIST PRICE

\$111

NOTES: Fits in 3" round grommet holes. Field installed with Plug-and-play ease. Two grounded AC power outlets. Includes 6' cord with three-prong plug.

ⓘ Available in black only (no color designation so use .X)

HGRMTAC2

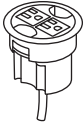

SIN 33721T

3' ROUND POWER GROMMET

2 Outlets, 10' Cord

DIMENSIONS

Ship Weight: 1.5
Cube: 0.2

LIST PRICE

\$148

NOTES: Power Modules will also work with standing-height applications for 10500 Series™ and Voi® desks. Optional Memory Control allows preset worksurface heights for consistency. Ships separately. Dynamic load capacity when worksurface is moving is 300 lbs. Includes 10' cord with three-prong plug. Fits in 3" round grommet holes on the following product lines: Coordinate™, Huddle, Motivate®, all laminate and veneer casework series, and Systems Worksurfaces. Two grounded AC power outlets. Field installed with Plug-and-play ease.

ⓘ Available in black finish only, no specification needed.

HGRMTUSB2



SIN 33721T

POWER/USB HUB

3" Grommet Mount

DIMENSIONS

Ship Weight: 1.3 ⓘ
Cube: 0.2

LIST PRICE

\$224

NOTES: One grounded AC power outlet with 2 USB ports. UL Listed.

ⓘ Available in black only (no color designation so use .X)

HGRMTDATA



SIN 33721

DATA GROMMET

DIMENSIONS

Ship Weight: 0.2
Cube: 0.2

LIST PRICE

\$19

NOTES: Blank grommet kit that includes adapters for a variety of manufacturers jacks and couplers. Fits in existing 3" round grommet housing.

ⓘ Available in black only (no color designation so use .P)

HPWRMOD3UWM

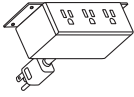

SIN 33721

POWER MODULE

3 Receptacles with Under-Worksurface Mounting Bracket

DIMENSIONS

Ship Weight: 2.3 ⓘ
Cube: 0.2

LIST PRICE

\$307

NOTES: 6' power cord with standard three-prong plug. Under-worksurface mounting bracket models work with any top that has a 5" x 5" square clearance. Worksurface clamp models work on any top with a 4" overhang. UL Listed.

ⓘ Color finish coordinates with HON's Charcoal or White. Specify S for Charcoal or WHIT for White when ordering.

Example: HPWRMOD3UWM.S.

HPWRMOD2UWM

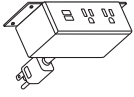

SIN 33721

POWER MODULE

2 Receptacles 2 USB with Under-Worksurface Mounting Bracket

DIMENSIONS

Ship Weight: 2.3 ⓘ
Cube: 0.2

LIST PRICE

\$491

NOTES: 6' power cord with standard three-prong plug. Under-worksurface mounting bracket models work with any top that has a 5" x 5" square clearance. Worksurface clamp models work on any top with a 4" overhang. UL Listed.

ⓘ Color finish coordinates with HON's Charcoal or White. Specify S for Charcoal or WHIT for White when ordering.

Example: HPWRMOD2UWM.S.

HON Recommendation: HGRMTUSB2.X - List Price \$224

HOW TO SPECIFY

Select Model Number

H	G	R	M	T	A	C
---	---	---	---	---	---	---

GATEWAY™



Gateway™ Chairs shown with Huddle Tables.

GATEWAY™

So you need a new chair, but it has to look as cool as it is comfortable. We've got you covered. Gateway takes the complexity out of finding the perfect chair by focusing on exactly what you're looking for. Cool, breathable mesh. Personalized seat fabrics. Targeted back support. Just what you need. Nothing you don't. All at a price you'll have to look at twice to make sure it's not a typo.



FEATURES

- Seat has comfortable, waterfall edge.
- Mesh back material flexes for a relaxed fit.
- Adjustable lumbar.
- Adjustable tilt to recline based on body type.
- Three arm options.
- Carton is 2 cubic feet smaller than the industry average.

HON BRANDED FABRICS

GRADE 1

Centurion
Contourett Polyurethane

GRADE 2

Dotty

For a complete list of fabrics, including partnership fabrics, go to hon.com/fabricsandfinishes.

Reference Fabric Color Combinations on pages 18-22 for color codes and legend on page 19 for lead times.

 For Fire Code model, availability and ordering method, refer to pages 26-29. Available on select models, contact HON Customer Support for availability.

GATEWAY™ Standard Task Chair

OPEN MARKET



Icon Legend on page 15

HGTMM

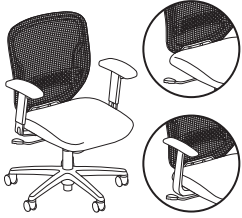

TASK CHAIR

Mesh Back
Pneumatic
Swivel
Tilt Tension
Tilt Lock
Adjustable Lumbar Support
Functions: **A, E, F, K, L, W**
(Function Key on pages 16-17)
NOTES: **HON 5-Year Limited Warranty.**

DIMENSIONS

Depth:	25¼	Seat to Floor Height:	17-22
Width:	27	Usable Seat Depth:	19
Height:	38	Ship Weight:	35
Seat Depth:	19	Cube:	3.4
Seat Width:	18½	Weight Rating:	250 lbs.
Back Width:	18		
Back Height:	18½		

FABRIC PRICE CODES

1 \$265
2 \$277

HOW TO SPECIFY

Select Model Number	Select Control Type	Select Arm Type	Select Caster	Select Back Type	Select Fabric	Select Lumbar	Select Base	Select Frame
	Z1 Swivel-Tilt Control	N Armless F Fixed Arms (+ \$35) H Height-Adjustable Arms (+ \$45)	H Hard Caster	M Mesh	See page 115	AL Adjustable Lumbar	SB Standard Base	T Black
HGTMM	Z1	H	H	M	CU10	AL	SB	T



GATEWAY™

Value Task Chair

HGV1MM



TASK CHAIR VALUE MODEL

Mesh Back

- Pneumatic
- Swivel
- Tilt Tension
- Tilt Lock
- Adjustable Lumbar Support

Functions: **A, E, F, K, L, W**
(Function Key on pages 16-17)

NOTES: **HON 5-Year Limited Warranty.**

DIMENSIONS

Depth:	25¼	Seat to Floor Height:	17-22
Width:	27	Usable Seat Depth:	19
Height:	38	Ship Weight:	35
Seat Depth:	19	Cube:	3.4
Seat Width:	18½	Weight Rating:	250 lbs.
Back Width:	18		
Back Height:	18½		

LIST PRICE

\$236

HOW TO SPECIFY

Select Model Number	Select Control Type	Select Arm Type	Select Caster	Select Back Type	Select Fabric	Select Lumbar	Select Base	Select Frame
	Z1 Swivel-Tilt Control	N Armless F Fixed Arms (+ \$35) H Height-Adjustable Arms (+ \$45)	H Hard Caster	M Mesh	ACCF10 Black	AL Adjustable Lumbar	SB Standard Base	T Black
HGV1MM	Z1	H	H	M	ACCF10	AL	SB	T



Grove® Lounge shown with Flock® Table.

GROVE®

Find a comfy place to put your feet up, huddle up and power up. Grove is the versatile lounge seating designed to help you greet, meet, focus, relax and accomplish more. This change-of-pace collection delivers the comfort people crave, while encouraging focus and interaction throughout the workplace. Grove's attractive design is rivaled only by its flexibility. Models include a single seat, two-seat, three-seat, and two-seat with table — all with three arm style and two leg style options, as well as accessories that support connectivity and collaboration. Grove has the look you're going for, and the comfort and versatility people have been waiting for.



FEATURES

- Each model can be combined to create arrangements suitable for any space.
- Optional integrated worksurfaces create more personal space and provide a convenient workspace.
- Design complements Flock ottomans and tables.
- Integrated power grommets keep laptops and phone powered up anywhere.
- The dual fabric option coordinates two high-quality HON fabrics for a contemporary look.
- Choose from Single Seat, Two-Seat, Three-Seat Lounge, or Two-Seat with Table options.
- Choose from 3 arm options — Armless (N), Straight Arms (A), or Tapered Arm (B).
- Table available with two grommets and an accessory port option.
- Offers a table between the seats that provides separation and a usable workspace.
- Warranted for users up to 300 lbs.

MODEL OPTIONS

HML1S
HML1SDF - Dual Fabric

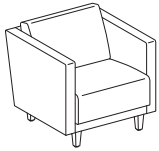

Lounge
Single Seat

HML2S
HML2SDF - Dual Fabric

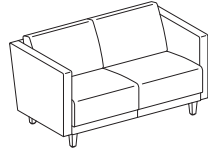

Lounge
Two-Seat

HML3S
HML3SDF - Dual Fabric

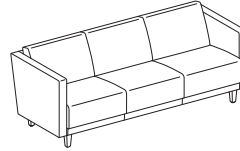

Lounge
Three-Seat

HML2ST
HML2STDF - Dual Fabric

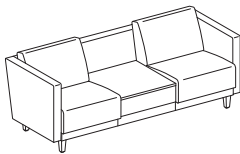

Lounge
Two-Seat with Table

GROVE® Options

ARM STYLE

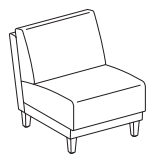

CODE	DESCRIPTION	PRICE
N	Armless	+\$0

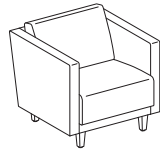

A	Straight Arms	+\$300
----------	---------------	---------------

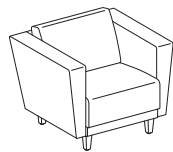

B	Tapered Arms	+\$350
----------	--------------	---------------

LEG STYLE



CODE	DESCRIPTION	PRICE
TS	Tapered Square	+\$0



TR	Tapered Round	+\$0
-----------	---------------	-------------

LEG COLOR

CODE	DESCRIPTION	PRICE
PR8	Textured Silver	+\$0
P7A	Textured Charcoal	+\$0
H	Bourbon Cherry	+\$100
F	Shaker Cherry	+\$100
N	Mahogany	+\$100
C	Harvest	+\$100
D	Natural Maple	+\$100
MOCH	Mocha	+\$100
PINC	Pinnacle	+\$100
COGN	Cognac	+\$100
LLA1	Lowell Ash	+\$100
LNRI	Natural Recon	+\$100
LPE1	Phantom Ecru	+\$100
LPT1	Portico Teak	+\$100
LSW1	Skyline Walnut	+\$100

L1 LAMINATE COLOR CODE

Black	P
Bourbon Cherry	H
Designer White	LDW1
Charcoal	S
Cognac	COGN
Florence Walnut	LFW1
Harvest	C
Kingswood Walnut	LK11
Loft	LOFT
Mahogany	N
Mocha	MOCH
Natural Maple	D
Pinnacle	PINC
Shaker Cherry	F

L2 LAMINATE COLOR CODE

Lowell Ash	LLA1
Natural Recon	LNRI
Phantom Ecru	LPE1
Portico Teak	LPT1
Skyline Walnut	LSW1

*Specify for models HML2ST and HML2STDF only

CUT OUT

CODE	DESCRIPTION	PRICE
N	No Cutout	+\$0
G	Round Grommet Cutout	+\$30
G1	Pop-Up Port Cutout	+\$40

*Specify for models HML2ST and HML2STDF only

ACCESSORY PORT LOCATION

CODE	DESCRIPTION	PRICE
0	No Port	+\$0
2	Two Tablet Ports Opposite	+\$20

*Specify for models HML2ST and HML2STDF only

HON BRANDED FABRICS

GRADE 1

Centurion
Compass
Contourett Polyurethane
Dapper
Hamilton
Inertia
Optic

GRADE 2

Appoint Seating
Clyde
Dotty
Rush
Seed
Spin Seating
Whisper Vinyl

GRADE 3

In Season
Purl
Silvertex™ Vinyl

GRADE L

Denver Leather

For a complete list of fabrics, including partnership fabrics, go to hon.com/fabricsandfinishes.

Reference Fabric Color Combinations on pages 18-22 for color codes and legend on page 19 for lead times. For additional HON to Supply COM fabric grade pricing, go to honready.hon.com and click on the HON to Supply COM link.

⚠ For Fire Code model, availability and ordering method, refer to pages 26-29. Available on select models, contact HON Customer Support for availability.

⚠ Due to the inherent characteristics of upholstery materials, the seat of Grove® may become more relaxed to show wrinkles over time.

DUAL FABRIC COM YARDAGE

Due to fabric pattern nesting and potential reduction of fabric yield, some dual fabric models may require more total yardage than standard models.

MODEL	COM (ARMLESS)		COM (w/ STRAIGHT ARMS)		COM (w/ TAPERED ARMS)	
	Back	Seat	Back	Seat	Back	Seat
HML1S	3		5		5	
HML1SDF	1.5	2	4	2	4	2
HML2S	5		7.5		7.5	
HML2SDF	2	3.5	4	3.5	4	3.5
HML2ST	6		8		8	
HML2STDF	3	3.5	5.5	3.5	5.5	3.5
HML3	7.5		9		9.5	
HML3DF	3	5	5.5	5	5.5	5

HML1S

LOUNGE

Single Seat

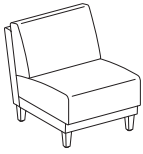

Armless

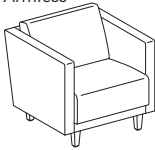

Straight Arms

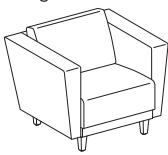

Tapered Arms

DIMENSIONS

Depth:	31½	Ship Weight (armless):	61
Height:	35	Ship Weight (with straight arms):	77
Seat Width:	23½	Ship Weight (with tapered arms):	85
Back Width:	23½	Cube (armless):	19.8
Back Height:	19	Cube (with straight arms):	19.8
Width (armless):	23½	Cube (with tapered arms):	19.8
Width (with straight arms):	29¾	COM:	See
Width (with tapered arms):	35		page 121
Arm Width:	23½	Weight Rating:	300 lbs.
Seat to Floor Height:	16		(per seat)
Usable Seat Depth:	18¾		

FABRIC PRICE CODES

1	\$1284	8	\$1698
2	\$1356	9	\$1752
3	\$1428	10	\$1806
4	\$1482	11	\$1860
5	\$1536	12	\$1914
6	\$1590	L	\$1884
7	\$1644		

HML2S

LOUNGE

Two-Seat

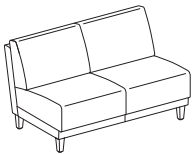

Armless



Straight Arms

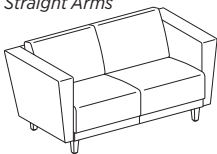

Tapered Arms

DIMENSIONS

Depth:	31½	Ship Weight (armless):	100
Height:	35	Ship Weight (with straight arms):	116
Seat Width:	48	Ship Weight (with tapered arms):	124
Back Width:	48	Cube (armless):	35.6
Back Height:	19	Cube (with straight arms):	35.6
Width (armless):	48	Cube (with tapered arms):	35.6
Width (with straight arms):	54¼	COM:	See
Width (with tapered arms):	59½		page 121
Arm Width:	48	Weight Rating:	300 lbs.
Seat to Floor Height:	16		(per seat)
Usable Seat Depth:	18¾		

FABRIC PRICE CODES

1	\$2047	8	\$2737
2	\$2167	9	\$2827
3	\$2287	10	\$2917
4	\$2377	11	\$3007
5	\$2467	12	\$3097
6	\$2557	L	\$3047
7	\$2647		

HON Recommendation: HML1S.A.PNS__TS.P7A - List Price \$1656

HOW TO SPECIFY

Select Model Number H M L 1 S .	Select Arm Type N Armless A Straight Arms (+ \$300) B Tapered Arms (+ \$350) A .	Select Fabric See page 121 P N S 0 0 7 .	Select Leg Type TS Tapered Square TR Tapered Round T S .	Select Leg Color PR8 Textured Silver P7A Textured Charcoal H Bourbon Cherry (+ \$100) F Shaker Cherry (+ \$100) N Mahogany (+ \$100) C Harvest (+ \$100) D Natural Maple (+ \$100) MOCH Mocha (+ \$100) PINC Pinnacle (+ \$100) COGN Cognac (+ \$100) LLA1 Lowell Ash (+ \$100) LNRI Natural Recon (+ \$100) LPE1 Phantom E cru (+ \$100) LPT1 Portico Teak (+ \$100) LSW1 Skyline Walnut (+ \$100) P 7 A
---	---	---	--	--

! Leg options – Tapered Square (TS) and Tapered Round (TR) are available in 2 poly and 13 woodgrain options.



HML3S

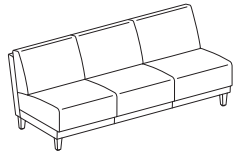

Armless

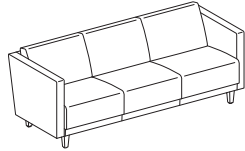

Straight Arms

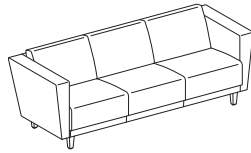

Tapered Arms

LOUNGE

Three-Seat

DIMENSIONS

Depth:	31½	Ship Weight (armless):	141
Height:	35	Ship Weight (with straight arms):	157
Seat Width:	71½	Ship Weight (with tapered arms):	165
Back Width:	71½	Cube (armless):	48.9
Back Height:	19	Cube (with straight arms):	48.9
Width (armless):	71½	Cube (with tapered arms):	48.9
Width (with straight arms):	77½	COM:	See
Width (with tapered arms):	82½		page 121
Arm Width:	71½	Weight Rating:	300 lbs.
Seat to Floor Height:	16		(per seat)
Usable Seat Depth:	18¾		

FABRIC PRICE CODES

1	\$2721	8	\$3756
2	\$2901	9	\$3891
3	\$3081	10	\$4026
4	\$3216	11	\$4161
5	\$3351	12	\$4296
6	\$3486	L	\$4221
7	\$3621		

HON Recommendation: HML3S.A.PNS__TS.P7A - List Price \$3201

HOW TO SPECIFY

<p>Select Model Number</p>	<p>Select Arm Type</p> <p>N Armless A Straight Arms (+ \$300) B Tapered Arms (+ \$350)</p>	<p>Select Fabric</p> <p>See page 121</p>	<p>Select Leg Type</p> <p>TS Tapered Square TR Tapered Round</p>	<p>Select Leg Color</p> <p>PR8 Textured Silver P7A Textured Charcoal H Bourbon Cherry (+ \$100) F Shaker Cherry (+ \$100) N Mahogany (+ \$100) C Harvest (+ \$100) D Natural Maple (+ \$100) MOCH Mocha (+ \$100) PINC Pinnacle (+ \$100) COGN Cognac (+ \$100) LLA1 Lowell Ash (+ \$100) LNR1 Natural Recon (+ \$100) LPE1 Phantom Ecu (+ \$100) LPT1 Portico Teak (+ \$100) LSW1 Skyline Walnut (+ \$100)</p>
<p>H M L 3 S .</p>	<p>A .</p>	<p>P N S 0 0 7 .</p>	<p>T S .</p>	<p>P 7 A</p>

! Leg options - Tapered Square (TS) and Tapered Round (TR) are available in 2 poly and 13 woodgrain options.

HML2ST

LOUNGE

Two-Seat with Table

DIMENSIONS

Depth:	31½	Ship Weight (armless):	146
Height:	35	Ship Weight (with straight arms):	162
Seat Width:	71½	Ship Weight (with tapered arms):	170
Back Width:	71½	Cube (armless):	48.9
Back Height:	19	Cube (with straight arms):	48.9
Width (armless):	71½	Cube (with tapered arms):	48.9
Width (with straight arms):	77½	COM:	See
Width (with tapered arms):	82½		page 121
Arm Width:	71½	Weight Rating:	300 lbs.
Seat to Floor Height:	16		(per seat)
Usable Seat Depth:	18¾		

FABRIC PRICE CODES

1	\$2959	8	\$3787
2	\$3103	9	\$3895
3	\$3247	10	\$4003
4	\$3355	11	\$4111
5	\$3463	12	\$4219
6	\$3571	L	\$4159
7	\$3679		

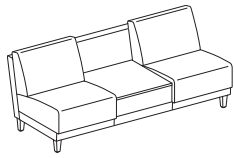

Armless

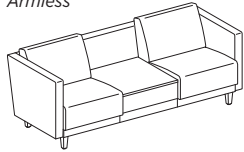

Straight Arms

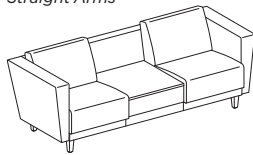

Tapered Arms

NOTES: Offers a table between the seats that provides separation and a usable worksurface. Table available with two grommet and an accessory port option.

HON Recommendation: HML2ST.A.PNS__TS.P7A.N.G1.0 - List Price \$3443

HOW TO SPECIFY

Select Model Number	Select Arm Type	Select Fabric	Select Leg Type	Select Leg Color	Select Laminate	Select Cut Out	Accessory Port Location
HML2ST	<p>N Armless</p> <p>A Straight Arms (+ \$300)</p> <p>B Tapered Arms (+ \$350)</p>	See page 121	<p>TS Tapered Square</p> <p>TR Tapered Round</p>	<p>PR8 Textured Silver</p> <p>P7A Textured Charcoal</p> <p>H Bourbon Cherry (+ \$100)</p> <p>F Shaker Cherry (+ \$100)</p> <p>N Mahogany (+ \$100)</p> <p>C Harvest (+ \$100)</p> <p>D Natural Maple (+ \$100)</p> <p>MOCH Mocha (+ \$100)</p> <p>PINC Pinnacle (+ \$100)</p> <p>COGN Cognac (+ \$100)</p> <p>LLA1 Lowell Ash (+ \$100)</p> <p>LNRI Natural Recon (+ \$100)</p> <p>LPE1 Phantom Ecru (+ \$100)</p> <p>LPT1 Portico Teak (+ \$100)</p> <p>LSW1 Skyline Walnut (+ \$100)</p>	See Chart on page 120 L2 (+ \$125)	<p>N No Cutout</p> <p>G Round Grommet Cutout (+ \$30)</p> <p>G1 Pop-Up Port Cutout (+ \$40)</p>	<p>0 No Port</p> <p>2 Two Tablet Ports Opposite (+ \$20)</p>
HML2ST	A	PNS007	TS	P7A	N	G1	0

! Leg options - Tapered Square (TS) and Tapered Round (TR) are available in 2 poly and 8 woodgrain options.



HGRMTAC

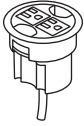

SIN 33721T

POWER HUB

3" Grommet Mount, 6' Cord

DIMENSIONS

Ship Weight: 1.3
Cube: 0.2

LIST PRICE

\$111

NOTES: Fits in 3" round grommet holes. Field installed with Plug-and-play ease. Two grounded AC power outlets. Includes 6' cord with three-prong plug.

ⓘ Available in black only (no color designation so use .X)

HGRMTAC2

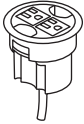

SIN 33721T

3" ROUND POWER GROMMET

2 Outlets, 10' Cord

DIMENSIONS

Ship Weight: 1.5
Cube: 0.2

LIST PRICE

\$148

NOTES: Power Modules will also work with standing-height applications for 10500 Series™ and Voi® desks. Optional Memory Control allows preset worksurface heights for consistency. Ships separately. Dynamic load capacity when worksurface is moving is 300 lbs. Includes 10' cord with three-prong plug. Fits in 3" round grommet holes on the following product lines: Coordinate™, Huddle, Motivate®, all laminate and veneer casegoods series, and Systems Worksurfaces. Two grounded AC power outlets. Field installed with Plug-and-play ease.

ⓘ Available in black finish only, no specification needed.

HGRMTUSB2

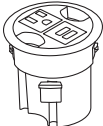

SIN 33721T

POWER/USB HUB

3" Grommet Mount

DIMENSIONS

Ship Weight: 1.3 ⓘ
Cube: 0.2

LIST PRICE

\$224

NOTES: One grounded AC power outlet with 2 USB ports. UL Listed.

ⓘ Available in black only (no color designation so use .X)

HFTTAL14



SIN 33721

TABLET ACCESSORY

Laminate

DIMENSIONS

Diameter: 14 Ship Weight: 6.0
Height from Table Top: 10 Cube: 2.5

LIST PRICE

\$368

NOTES: Use with Collaborative Cube and Cylinder tables for additional workspace. Attaches to tables through ports. Multiple port location options are available. Tablet pivots/swivels toward the user.

HTPWRGROM1

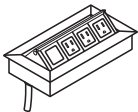

SIN 33721

POP-UP PORT

DIMENSIONS

Ship Weight: 5.0
Cube: 0.3

LIST PRICE

\$392

NOTES: Fits into 4" x 8" cutout. Specify G1 cutout in table top. Pop-up Port provides three power ports and one blank data receptacle. Sits flush with worksurface when closed. Finish is anodized aluminum. Includes 6' cord with three-prong plug.

HON Recommendation: HTPWRGROM1 - List Price \$392

HOW TO SPECIFY

Select Model Number

H	G	R	M	T	A	C
---	---	---	---	---	---	---

GROVE® Dual Fabric

GSA SIN 33721



Icon Legend on page 15

HML1SDF

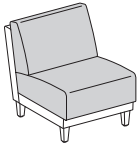

Armless

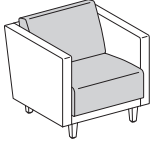

Straight Arms

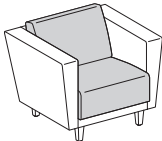

Tapered Arms

SINGLE SEAT LOUNGE

Dual Fabric

DIMENSIONS

Depth:	31½	Ship Weight (armless):	61
Height:	35	Ship Weight (with straight arms):	77
Seat Width:	23½	Ship Weight (with tapered arms):	85
Back Width:	23½	Cube (armless):	19.8
Back Height:	19	Cube (with straight arms):	19.8
Width (armless):	23½	Cube (with tapered arms):	19.8
Width (with straight arms):	29¾	COM:	
Width (with tapered arms):	35	See	page 121
Arm Width:	23½	Weight Rating:	300 lbs. (per seat)
Seat to Floor Height:	16		
Usable Seat Depth:	18¾		

FABRIC PRICE CODES

1 \$1377

Add to Base Price Above

	Frame/ Arms	Back/Seat Cushions
2	\$36	\$48
3	\$72	\$96
4	\$99	\$132
5	\$126	\$168
6	\$153	\$204
7	\$180	\$240
8	\$207	\$276
9	\$234	\$312
10	\$261	\$348
11	\$288	\$384
12	\$315	\$420
L	\$300	\$400

For dual fabric models, start with the base price, then add the additional amount for the back and seat from the corresponding matrix to determine the final list price. Choose any combination of fabric grades for the back and seat.

Example: HML1SDF base price (\$1377) + Grade 2 frame/arms fabric (add \$36) + Grade 4 back/seat fabric (add \$132) = Total \$1545 List
 HML1SDF base price (\$1377) + Grade 5 frame/arms fabric (add \$126) + Grade 3 back/seat fabric (add \$96) = Total \$1599 List

HON Recommendation: HML1SDF.A.PNS___.PNS___.TS.P7A - List Price \$1761

HOW TO SPECIFY

Select Model Number H M L 1 S D F .	Select Arm Type N Armless A Straight Arms (+ \$300) B Tapered Arms (+ \$350)	Select Frame/Arms Fabric See page 121	Select Back/Seat Cushions Fabric See page 121	Select Leg Type TS Tapered Square TR Tapered Round	Select Leg Color PR8 Textured Silver P7A Textured Charcoal H Bourbon Cherry (+ \$100) F Shaker Cherry (+ \$100) N Mahogany (+ \$100) C Harvest (+ \$100) D Natural Maple (+ \$100) MOCH Mocha (+ \$100) PINC Pinnacle (+ \$100) COGN Cognac (+ \$100) LLA1 Lowell Ash (+ \$100) LNR1 Natural Recon (+ \$100) LPE1 Phantom Ecru (+ \$100) LPT1 Portico Teak (+ \$100) LSW1 Skyline Walnut (+ \$100)
H M L 1 S D F .	A .	P N S 0 0 4 .	P N S 0 0 7 .	T S .	P 7 A

! Leg options - Tapered Square (TS) and Tapered Round (TR) are available in 2 poly and 8 woodgrain options.



HML2SDF

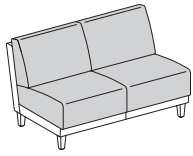

Armless

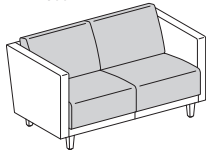

Straight Arms

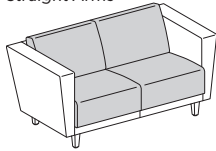

Tapered Arms

TWO-SEAT LOUNGE

Dual Fabric

DIMENSIONS

Depth:	31½	Ship Weight (armless):	100
Height:	35	Ship Weight (with straight arms):	116
Seat Width:	48	Ship Weight (with tapered arms):	124
Back Width:	48	Cube (armless):	35.6
Back Height:	19	Cube (with straight arms):	35.6
Width (armless):	48	Cube (with tapered arms):	35.6
Width (with straight arms):	54¼	COM:	See
Width (with tapered arms):	59½		page 121
Arm Width:	48	Weight Rating:	300 lbs.
Seat to Floor Height:	16		(per seat)
Usable Seat Depth:	18¾		

FABRIC PRICE CODES

1	\$2057		
<i>Add to Base Price Above</i>			
		Frame/ Arms	Back/Seat Cushions
2	\$60		\$84
3	\$120		\$168
4	\$165		\$231
5	\$210		\$294
6	\$255		\$357
7	\$300		\$420
8	\$345		\$483
9	\$390		\$546
10	\$435		\$609
11	\$480		\$672
12	\$525		\$735
L	\$500		\$700

For dual fabric models, start with the base price, then add the additional amount for the back and seat from the corresponding matrix to determine the final list price. Choose any combination of fabric grades for the back and seat.

Example: HML2SDF base price (\$2057) + Grade 2 frame/arms fabric (add \$60) + Grade 4 back/seat fabric (add \$231) = Total \$2348 List
 HML2SDF base price (\$2057) + Grade 5 frame/arms fabric (add \$210) + Grade 3 back/seat fabric (add \$168) = Total \$2435 List

HON Recommendation: HML2SDF.A.PNS__PNS__TS.P7A - List Price \$2501

HOW TO SPECIFY

Select Model Number	Select Arm Type	Select Frame/Arms Fabric	Select Back/Seat Cushions Fabric	Select Leg Type	Select Leg Color
	N Armless A Straight Arms (+ \$300) B Tapered Arms (+ \$350)	See page 121	See page 121	TS Tapered Square TR Tapered Round	PR8 Textured Silver P7A Textured Charcoal H Bourbon Cherry (+ \$100) F Shaker Cherry (+ \$100) N Mahogany (+ \$100) C Harvest (+ \$100) D Natural Maple (+ \$100) MOCH Mocha (+ \$100) PINC Pinnacle (+ \$100) COGN Cognac (+ \$100) LLA1 Lowell Ash (+ \$100) LNR1 Natural Recon (+ \$100) LPE1 Phantom Ecru (+ \$100) LPT1 Portico Teak (+ \$100) LSW1 Skyline Walnut (+ \$100)
HML2SDF	A	PNS004	PNS007	TS	P7A

! Leg options - Tapered Square (TS) and Tapered Round (TR) are available in 2 poly and 8 woodgrain options.

GROVE® Dual Fabric

GSA SIN 33721



Icon Legend on page 15

HML3SDF

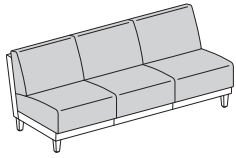

Armless

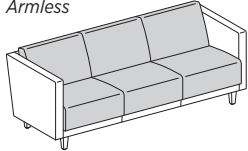

Straight Arms

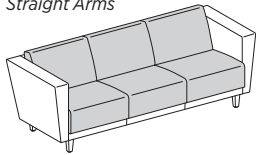

Tapered Arms

THREE-SEAT LOUNGE

Dual Fabric

DIMENSIONS

Depth:	31½	Ship Weight (armless):	141
Height:	35	Ship Weight (with straight arms):	157
Seat Width:	71½	Ship Weight (with tapered arms):	165
Back Width:	71½	Cube (armless):	48.9
Back Height:	19	Cube (with straight arms):	48.9
Width (armless):	71½	Cube (with tapered arms):	48.9
Width (with straight arms):	77½	COM:	
Width (with tapered arms):	82½	See	page 121
Arm Width:	71½	Weight Rating:	300 lbs.
Seat to Floor Height:	16	(per seat)	
Usable Seat Depth:	18¾		

FABRIC PRICE CODES

1	\$2831		
<i>Add to Base Price Above</i>			
	Frame/ Arms	Back/Seat Cushions	
2	\$72	\$132	
3	\$144	\$264	
4	\$198	\$363	
5	\$252	\$462	
6	\$306	\$561	
7	\$360	\$660	
8	\$414	\$759	
9	\$468	\$858	
10	\$522	\$957	
11	\$576	\$1056	
12	\$630	\$1155	
L	\$600	\$1100	

For dual fabric models, start with the base price, then add the additional amount for the back and seat from the corresponding matrix to determine the final list price. Choose any combination of fabric grades for the back and seat.

Example: HML3SDF base price (\$2831) + Grade 2 frame/arms fabric (add \$72) + Grade 4 back/seat fabric (add \$363) = Total \$3266 List
 HML3SDF base price (\$2831) + Grade 5 frame/arms fabric (add \$252) + Grade 3 back/seat fabric (add \$264) = Total \$3347 List

HON Recommendation: HML3SDF.A.PNS__PNS__.TS.P7A - List Price \$3335

HOW TO SPECIFY

Select Model Number	Select Arm Type	Select Frame/Arms Fabric	Select Back/Seat Cushions Fabric	Select Leg Type	Select Leg Color
	N Armless A Straight Arms (+ \$300) B Tapered Arms (+ \$350)	See page 121	See page 121	TS Tapered Square TR Tapered Round	PR8 Textured Silver P7A Textured Charcoal H Bourbon Cherry (+ \$100) F Shaker Cherry (+ \$100) N Mahogany (+ \$100) C Harvest (+ \$100) D Natural Maple (+ \$100) MOCH Mocha (+ \$100) PINC Pinnacle (+ \$100) COGN Cognac (+ \$100) LLA1 Lowell Ash (+ \$100) LNR1 Natural Recon (+ \$100) LPE1 Phantom Ecru (+ \$100) LPT1 Portico Teak (+ \$100) LSW1 Skyline Walnut (+ \$100)
HML3SDF	A	PNS004	PNS007	TS	P7A

! Leg options - Tapered Square (TS) and Tapered Round (TR) are available in 2 poly and 8 woodgrain options.



HML2STDF

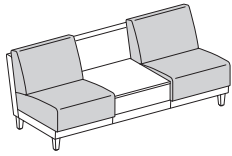

Armless

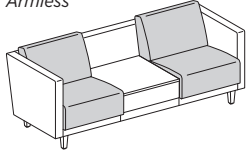

Straight Arms

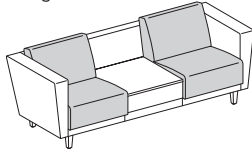

Tapered Arms

TWO-SEAT WITH TABLE

Dual Fabric

DIMENSIONS

Depth:	31½	Ship Weight (armless):	146
Height:	35	Ship Weight (with straight arms):	162
Seat Width:	71½	Ship Weight (with tapered arms):	170
Back Width:	71½	Cube (armless):	48.9
Back Height:	19	Cube (with straight arms):	48.9
Width (armless):	71½	Cube (with tapered arms):	48.9
Width (with straight arms):	77½	COM:	See
Width (with tapered arms):	82½	Weight Rating:	page 121
Arm Width:	71½		300 lbs.
Seat to Floor Height:	16		(per seat)
Usable Seat Depth:	18¾		

FABRIC PRICE CODES

1	\$3043		
<i>Add to Base Price Above</i>			
	Frame/Arms	Back/Seat Cushions	
2	\$72	\$84	
3	\$144	\$168	
4	\$198	\$231	
5	\$252	\$294	
6	\$306	\$357	
7	\$360	\$420	
8	\$414	\$483	
9	\$468	\$546	
10	\$522	\$609	
11	\$576	\$672	
12	\$630	\$735	
L	\$600	\$700	

NOTES: Offers a table between the seats that provides separation and a usable worksurface. Table available with two grommet and an accessory port option.

HON Recommendation: HML2STDF.A.PNS__PNS__TS.P7A.N.G1.0 - List Price \$3539

HOW TO SPECIFY

Select Model Number	Select Arm Type	Select Frame/Arms Fabric	Select Back/Seat Cushions Fabric	Select Leg Type	Select Leg Color	Select Laminate	Select Cut Out	Accessory Port Location
	N Armless A Straight Arms (+ \$300) B Tapered Arms (+ \$350)	See page 121	See page 121	TS Tapered Square TR Tapered Round	PR8 Textured Silver P7A Textured Charcoal H Bourbon Cherry (+ \$100) F Shaker Cherry (+ \$100) N Mahogany (+ \$100) C Harvest (+ \$100) D Natural Maple (+ \$100) MOCH Mocha (+ \$100) PINC Pinnacle (+ \$100) COGN Cognac (+ \$100) LLA1 Lowell Ash (+ \$100) LNRI Natural Recon (+ \$100) LPE1 Phantom Ecru (+ \$100) LPT1 Portico Teak (+ \$100) LSW1 Skyline Walnut (+ \$100)	See Chart on page 120 L2 (+ \$125)	N No Cutout G Round Grommet Cutout (+ \$30) G1 Pop-Up Port Cutout (+ \$40)	0 No Port 2 Two Tablet Ports Opposite (+ \$20)
HML2STDF	A	PNS004	PNS007	TS	P7A	N	G1	0

! Leg options - Tapered Square (TS) and Tapered Round (TR) are available in 2 poly and 8 woodgrain options.

HGRMTAC

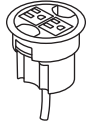

SIN 33721T

POWER HUB

3" Grommet Mount, 6' Cord

DIMENSIONS

Ship Weight: 1.3
Cube: 0.2

LIST PRICE

\$111

NOTES: Fits in 3" round grommet holes. Field installed with Plug-and-play ease. Two grounded AC power outlets. Includes 6' cord with three-prong plug.

ⓘ Available in black only (no color designation so use .X)

HGRMTAC2

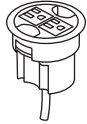

SIN 33721T

3" ROUND POWER GROMMET

2 Outlets, 10' Cord

DIMENSIONS

Ship Weight: 1.5
Cube: 0.2

LIST PRICE

\$148

NOTES: Power Modules will also work with standing-height applications for 10500 Series™ and Voi® desks. Optional Memory Control allows preset worksurface heights for consistency. Ships separately. Dynamic load capacity when worksurface is moving is 300 lbs. Includes 10' cord with three-prong plug. Fits in 3" round grommet holes on the following product lines: Coordinate™, Huddle, Motivate®, all laminate and veneer casegoods series, and Systems Worksurfaces. Two grounded AC power outlets. Field installed with Plug-and-play ease.

ⓘ Available in black finish only, no specification needed.

HGRMTUSB2



SIN 33721T

POWER/USB HUB

3" Grommet Mount

DIMENSIONS

Ship Weight: 1.3 ⓘ
Cube: 0.2

LIST PRICE

\$224

NOTES: One grounded AC power outlet with 2 USB ports. UL Listed.

ⓘ Available in black only (no color designation so use .X)

HFTTAL14



SIN 33721

TABLET ACCESSORY

Laminate

DIMENSIONS

Diameter: 14 Ship Weight: 6.0
Height from Table Top: 10 Cube: 2.5

LIST PRICE

\$368

NOTES: Use with Collaborative Cube and Cylinder tables for additional workspace. Attaches to tables through ports. Multiple port location options are available. Tablet pivots/swivels toward the user.

HTPWGROM1

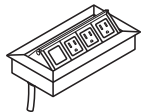

SIN 33721

POP-UP PORT

DIMENSIONS

Ship Weight: 5.0
Cube: 0.3

LIST PRICE

\$392

NOTES: Fits into 4" x 8" cutout. Specify G1 cutout in table top. Pop-up Port provides three power ports and one blank data receptacle. Sits flush with worksurface when closed. Finish is anodized aluminum. Includes 6' cord with three-prong plug. HON Recommendation: HTPWRGROM1 - List Price \$392

HON Recommendation: HTPWRGROM1 - List Price \$392

HOW TO SPECIFY

Select
Model Number

H G R M T A C

GUESTSTACKER® 4030 Series



GuestStacker Stacking Chair shown in Regatta.

GUESTSTACKER® 4030 SERIES

Support your people with a comfortable chair whenever needed, then quickly clear the room. GuestStacker helps you make the most of valuable floor space by stacking six high on the floor or 28 high on a cart. Each set of four chairs provides ergonomic support to users with a contoured seat and back that are molded to fit the natural curves of your body. When you need to put guests at ease for any length of time, you need GuestStacker chairs.



FEATURES

- Ships four chairs per carton.
- Chairs stack six high on the floor.
- Copolymer resin seat and back shell.
- Integrated lumbar support delivers long-lasting comfort.
- Wall-saver design protects walls and cabinets.
- Tubular steel frame adds durability.
- Optional ganging glides create straight rows.
- Stacks up to 28 high on HON Model 4033 Cart.
- Ships fully assembled.
- Warranted for users up to 300 lbs.

GUESTSTACKER® 4030 Series

GSA SIN 33721



Icon Legend on page 15

H4031



STACKING CHAIRS

Textured Copolymer Seat & Back
Painted Legs — Black (T) ONLY

DIMENSIONS

Depth:	21½	Seat to Floor Height:	17½
Width:	21	Usable Seat Depth:	17½
Height:	31	Ship Weight:	51
Seat Depth:	19	Cube:	12.9
Seat Width:	18	Weight Rating:	300 lbs.
Back Width:	20		
Back Height:	11		

LIST PRICE PER CARTON

\$621
(reference single unit @ \$155.25)

- ⊕ 4030 Series is ordered and shipped four (4) chairs per carton. Pricing shown is per carton. Each set of four (one carton), must have the same shell/frame color combination. Ordering 2 of Model H4031 will result in 2 cartons being shipped, giving you 8 chairs.
- ⚠ Shipped fully assembled — 4 chairs per carton. All GuestStacker® shell colors are CA Technical Bulletin 133 compliant (no upcharge).

H4033

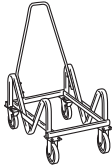

CART FOR STACKING CHAIRS

DIMENSIONS

Depth:	35½	Ship Weight:	40 Ⓢ
Width:	21¾	Cube:	8.9
Height:	37¾		

LIST PRICE

\$521

- NOTES: Holds 28 stack chairs (6'-8"), some assembly required. (Chairs stack 6 high without cart.)
⚠ Specify Black paint (T) ONLY.

H4039

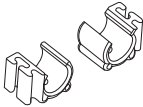

GANGING CHAIR GLIDES

Box of 48

DIMENSIONS

Ship Weight:	1 Ⓢ
Cube:	0.04

LIST PRICE

\$105

HON Recommendation: H4031.LA.T - List Price \$621

HOW TO SPECIFY

<p>Select Model Number</p> <p>H 4 0 3 1 .</p>	<p>Select Shell Color</p> <p>LA Lava MB Mulberry ON Onyx RE Regatta</p> <p>L A .</p>	<p>Select Frame</p> <p>T Black</p> <p>T</p>
--	---	--

IGNITION®



Ignition® 2.0 Task Chairs shown with Empower® Benching.

IGNITION®

People come in all shapes and sizes, which is why Ignition does as well. From guest and lounge chairs to executive seating, Ignition allows you to mix and match adjustment features, back height, lumbar, and other options to fit your chair to your needs. It's the easy, affordable way to furnish an entire workplace in style and comfort. Ignition fits who you are, where you work and how you work.



FEATURES

IGNITION®

- Ignition Series seating addresses the needs of the total office with Executive, Task, Stool, Guest and Lounge Seating Solutions.
- Three different back sizes, three different controls and multiple arm options to fit you and how you work.
- Back height adjustment moves the back up or down to fit various body sizes.
- Contoured back on multi-purpose seating offers greater comfort than typical stack chairs or stools.
- Warranted for users up to 300 lbs. (450 lbs. for Big and Tall)
- Multi-purpose chair stacks four high.

IGNITION® 2.0

- Choice of upholstered, 4-Way Stretch mesh or ReActiv® back options.
- ReActiv® back features zonal comfort that delivers optimal support and flexibility.
- The unique hammock-like inner support allows the upholstered back version to feature a slim profile and provide built-in comfort.
- Optional adjustable lumbar allows users to tailor their support.
- Passive movement back adjusts with you.
- Multiple arm options to accommodate user requirements.
- Available in 5 colors of 4-Way Stretch mesh and 2 ReActiv® colors.
- Molded foam seat for better support and added comfort.
- Available in Black and Titanium frame.
- Warranted for users up to 300 lbs.



IGNITION® Options

MODEL OPTIONS

HITL1



Task Low-Back

Pneumatic, Back Height Adjustment, Swivel, Tilt, Tilt Tension, Tilt Lock

HITL2



Task Low-Back

Pneumatic, Back Height Adjustment, Synchro-tilt, Tilt Tension, Tilt Lock, Seat Glide

HITL3



Task Low-Back

Pneumatic, Back Height Adjustment, Synchro-tilt, Back Angle Adjustment, Tilt Tension, Tilt Lock, Seat Glide

HITS5



Task Stool

Pneumatic, Swivel Back Height Adjustment, Adjustable Footrest

HIWM1



Mid-Back

Pneumatic, Back Height Adjustment, Swivel, Tilt, Tilt Tension, Tilt Lock

HIWM2



Mid-Back

Pneumatic, Back Height Adjustment, Synchro-tilt, Tilt Tension, Tilt Lock, Seat Glide

HIWM3



Mid-Back

Pneumatic, Back Height Adjustment, Synchro-tilt, Back Angle Adjustment, Tilt Tension, Tilt Lock, Seat Glide

HIEH1



Executive High-Back

Pneumatic, Back Height Adjustment, Swivel, Tilt, Tilt Tension, Tilt Lock

HIEH2



Executive High-Back

Pneumatic, Back Height Adjustment, Synchro-tilt, Tilt Tension, Seat Glide

HIEH3



Executive High-Back

Pneumatic, Back Height Adjustment, Synchro-tilt, Back Angle Adjustment, Tilt Tension, Seat Glide

HIWM8

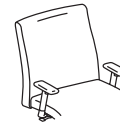

Task Mid-Back

Big and Tall, Pneumatic, Swivel-tilt, Tilt Tension

HITLM



Task Low-Back

4-Way Stretch Mesh Back, Pneumatic, Swivel, Synchro-tilt, Tilt Tension, Tilt Lock, Optional Lumbar Support

HITSM

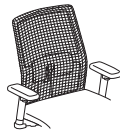

Task Low-Back Stool

4-Way Stretch Mesh Back, Pneumatic, Swivel, Synchro-tilt, Tilt Tension, Tilt Lock, Optional Lumbar Support

HITLRA



Task Low-Back ReActiv®

ReActiv® Back, Pneumatic, Swivel, Synchro-tilt, Tilt Tension, Tilt Lock, Optional Lumbar Support

HITSRA

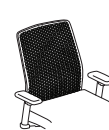

Task Low-Back Stool ReActiv®

ReActiv® Back, Pneumatic, Swivel, Synchro-tilt, Tilt Tension, Tilt Lock, Optional Lumbar Support

HIWMM



Task Mid-Back

4-Way Stretch Mesh Back, Pneumatic, Swivel, Synchro-tilt, Tilt Tension, Tilt Lock, Optional Lumbar Support

HIWMRA



Task Mid-Back ReActiv®

ReActiv® Back, Pneumatic, Swivel, Synchro-tilt, Tilt Tension, Tilt Lock, Optional Lumbar Support

HIWMU



Upholstered Mid-Back

Upholstered Back, Pneumatic, Swivel, Synchro-tilt, Tilt Tension, Tilt Lock, Optional Lumbar Support

HIWML



Upholstered Mid-Back with Lumbar Support

Upholstered Back, Pneumatic, Swivel, Synchro-tilt, Tilt Tension, Tilt Lock, Adjustable Lumbar

MODEL OPTIONS

HIGCL



Guest Chair

Fixed Arms, Glides

HIB50

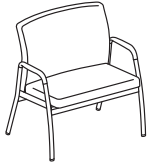

Bariatric Lounge

Fixed Arms, Glides

HIGS6

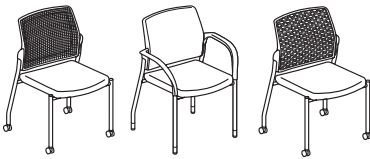

Multi-Purpose

Four Legs

HISB6

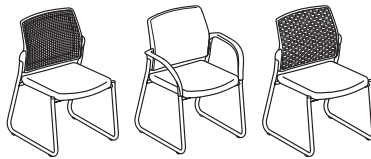

Multi-Purpose

Sled Base

HICS7

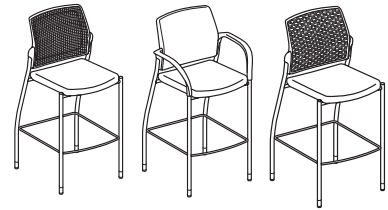

Café-Height Stool

Four Legs

HIGS6DF - Dual Fabric

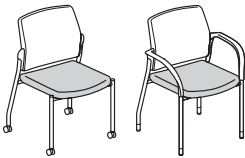

Multi-Purpose

Four Legs

HISB6DF - Dual Fabric

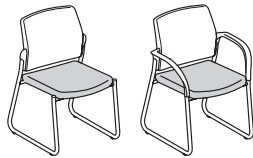

Multi-Purpose

Sled Base

HICS7DF - Dual Fabric

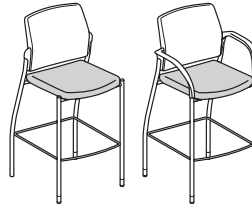





Café-Height Stool

Four Legs

IGNITION® Task Chair Options

ARM STYLE	CODE	DESCRIPTION	PRICE
	N	Armless	+\$0
	F	Fixed Arms	+\$65
	A	Height and Width Adjustable Arms	+\$75
	V	All-Adjustable Arms (includes Pivot)	+\$115
	P	Fixed Polished Aluminum Arms	+\$150

CASTERS	CODE	DESCRIPTION	PRICE
	A	All Surface Caster <i>*Must specify for model HIWM8 only</i>	+\$0
	H	Hard Caster	+\$0
	S	Soft Caster	+\$30

BACK STYLE	CODE	DESCRIPTION	PRICE
	U	Upholstered	+\$0
	M	Mesh	+\$0

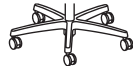
BASE	CODE	DESCRIPTION	PRICE
	SB	Standard Base	+\$0
	PA	Polished Aluminum	+\$110

HON BRANDED FABRICS

GRADE 1

Attire
Centurion
Compass
Contourett Polyurethane
Dapper
Hamilton
Inertia
Optic

GRADE 2

Appoint Seating
Clyde
Dotty
Rush
Seed
Spin Seating
Whisper Vinyl

GRADE 3

In Season
Purl
Silvertex™ Vinyl

GRADE L

Denver Leather*

For a complete list of fabrics, including partnership fabrics, go to hon.com/fabricsandfinishes.

Reference Fabric Color Combinations on pages 18-22 for color codes and legend on page 19 for lead times. For additional HON to Supply COM fabric grade pricing, go to honready.hon.com and click on the HON to Supply COM link.

*Denver Leather (SS) may not be available on every model within a specific series, please refer to the model's page for details.

 For Fire Code model, availability and ordering method, refer to pages 26-29. Available on select models, contact HON Customer Support for availability.



Icon Legend on page 15

HITL1



TASK LOW-BACK

Pneumatic
Back Height Adjustment
Swivel
Tilt
Tilt Tension
Tilt Lock
Functions: **A, B, E, J, K, L**
(Function Key on pages 16-17)

DIMENSIONS

Upholstered Back
Width: 17½
Upholstered Back
Height: 18¾-21¾
Mesh Back Width: 17½
Mesh Back Height: 20¾-23¼
Depth: 36
Width: 27½
Height: 41
Seat Depth: 17
Seat Width: 19

Adjustable Arms Width: 17-19½
Fixed Arms Width: 20
Seat to Floor Height: 17-21½
Usable Seat Depth: 15¾
Ship Weight (upholstered back): 50 **Ⓢ**
Ship Weight (mesh back): 45 **Ⓢ**
Cube (upholstered back): 10.8
Cube (mesh back): 10.8
COM (upholstered back): 2.0
COM (mesh back): 1.0
Weight Rating: 300 lbs.

FABRIC PRICE CODES

1	\$588	8	\$864
2	\$636	9	\$900
3	\$684	10	\$936
4	\$720	11	\$972
5	\$756	12	\$1008
6	\$792	L	—
7	\$828		

NOTES: See page 142 for arm packs.

HITL2



TASK LOW-BACK

Pneumatic
Back Height Adjustment
Synchro-tilt
Tilt Tension
Tilt Lock
Seat Glide
Functions: **A, B, D, E, J, A-D, L**
(Function Key on pages 16-17)

DIMENSIONS

Upholstered Back
Width: 17½
Upholstered Back
Height: 19½-22½
Mesh Back Width: 17½
Mesh Back Height: 20¾-23¼
Depth: 38½
Width: 27½
Height: 43
Seat Depth: 16-18
Seat Width: 19

Adjustable Arms Width: 17-19½
Fixed Arms Width: 20
Seat to Floor Height: 17-21½
Usable Seat Depth: 15½-17½
Ship Weight (upholstered back): 54 **Ⓢ**
Ship Weight (mesh back): 49 **Ⓢ**
Cube (upholstered back): 10.8
Cube (mesh back): 10.8
COM (upholstered back): 2.0
COM (mesh back): 1.0
Weight Rating: 300 lbs.

FABRIC PRICE CODES

1	\$662	8	\$938
2	\$710	9	\$974
3	\$758	10	\$1010
4	\$794	11	\$1046
5	\$830	12	\$1082
6	\$866	L	—
7	\$902		

NOTES: See page 142 for arm packs.

HITL3



TASK LOW-BACK

Pneumatic
Back Height Adjustment
Synchro-tilt
Back Angle Adjustment
Tilt Tension
Tilt Lock
Seat Glide
Functions: **A, B, D, E, A-D, A-E, L**
(Function Key on pages 16-17)

DIMENSIONS

Upholstered Back
Width: 17½
Upholstered Back
Height: 20¾-23¾
Mesh Back Width: 17½
Mesh Back Height: 20¾-23¼
Depth: 39
Width: 27
Height: 44
Seat Depth: 16-18
Seat Width: 19

Adjustable Arms Width: 17-19½
Fixed Arms Width: 20
Seat to Floor Height: 17-21½
Usable Seat Depth: 14½-16½
Ship Weight (upholstered back): 58 **Ⓢ**
Ship Weight (mesh back): 53 **Ⓢ**
Cube (upholstered back): 10.8
Cube (mesh back): 10.8
COM (upholstered back): 2.0
COM (mesh back): 1.0
Weight Rating: 300 lbs.

FABRIC PRICE CODES

1	\$707	8	\$983
2	\$755	9	\$1019
3	\$803	10	\$1055
4	\$839	11	\$1091
5	\$875	12	\$1127
6	\$911	L	—
7	\$947		

NOTES: See page 142 for arm packs.

HON Recommendation: HITL1.A.H.M.CU__T.SB - List Price \$663

HOW TO SPECIFY

Select Model Number HITL1	Select Arm Type N Armless F Fixed Arms - Black (+ \$65) A Height and Width Adjustable Arms (+ \$75) V All-Adjustable Arms (includes Pivot) (+ \$115) P Fixed Arms - Polished (+ \$150)	Select Caster/Glide H Hard Caster S Soft Caster (+ \$30)	Select Back Type U Upholstered M Mesh	Select Fabric See page 137	Select Frame T Black	Select Base SB Standard Base PA Polished Aluminum (+ \$110)
HITL1	A	H	M	CU10	T	SB



Icon Legend on page 15

HIWM1



MID-BACK

Pneumatic
Back Height Adjustment
Swivel
Tilt
Tilt Tension
Tilt Lock
Functions: **A, B, E, J, K, L**
(Function Key on pages 16-17)

DIMENSIONS

Upholstered Back Width: 18½
Upholstered Back Height: 21-24
Mesh Back Width: 19
Mesh Back Height: 21½-24
Depth: 35½
Width: 27
Height: 44
Seat Depth: 18
Seat Width: 20
Adjustable Arms Width: 18-20½
Fixed Arms Width: 20

Seat to Floor Height: 17-21½
Usable Seat Depth: 17½
Ship Weight (upholstered back): 54 **Ⓢ**
Ship Weight (mesh back): 48 **Ⓢ**
Cube (upholstered back): 10.8
Cube (mesh back): 10.8
COM (upholstered back): 2.0
COM (mesh back): 1.0
Weight Rating: 300 lbs.

FABRIC PRICE CODES

1	\$644	8	\$920
2	\$692	9	\$956
3	\$740	10	\$992
4	\$776	11	\$1028
5	\$812	12	\$1064
6	\$848	L	\$944
7	\$884		

NOTES: See page 142 for arm packs.

HIWM2



MID-BACK

Pneumatic
Back Height Adjustment
Synchro-tilt
Tilt Tension
Tilt Lock
Seat Glide
Functions:
A, B, D, E, J, A-D, L
(Function Key on pages 16-17)

DIMENSIONS

Upholstered Back Width: 18½
Upholstered Back Height: 21-24
Mesh Back Width: 19
Mesh Back Height: 21½-24
Depth: 38
Width: 27
Height: 46½
Seat Depth: 17-19
Seat Width: 20
Adjustable Arms Width: 18-20½
Fixed Arms Width: 20

Seat to Floor Height: 17¼-21¾
Usable Seat Depth: 16¼-18¼
Ship Weight (upholstered back): 58 **Ⓢ**
Ship Weight (mesh back): 52 **Ⓢ**
Cube (upholstered back): 10.8
Cube (mesh back): 10.8
COM (upholstered back): 2.0
COM (mesh back): 1.0
Weight Rating: 300 lbs.

FABRIC PRICE CODES

1	\$715	8	\$991
2	\$763	9	\$1027
3	\$811	10	\$1063
4	\$847	11	\$1099
5	\$883	12	\$1135
6	\$919	L	\$1015
7	\$955		

NOTES: See page 142 for arm packs.

HIWM3



MID-BACK

Pneumatic
Back Height Adjustment
Synchro-tilt
Back Angle Adjustment
Tilt Tension
Tilt Lock
Seat Glide
Functions:
A, B, D, E, A-D, A-E, L
(Function Key on pages 16-17)

DIMENSIONS

Upholstered Back Width: 18½
Upholstered Back Height: 21-24
Mesh Back Width: 19
Mesh Back Height: 21½-24
Depth: 39
Width: 27
Height: 44
Seat Depth: 17-19
Seat Width: 20
Adjustable Arms Width: 18-20½
Fixed Arms Width: 20

Seat to Floor Height: 17¼-21¾
Usable Seat Depth: 15¼-17¼
Ship Weight (upholstered back): 63 **Ⓢ**
Ship Weight (mesh back): 58 **Ⓢ**
Cube (upholstered back): 10.8
Cube (mesh back): 10.8
COM (upholstered back): 2.0
COM (mesh back): 1.0
Weight Rating: 300 lbs.

FABRIC PRICE CODES

1	\$762	8	\$1038
2	\$810	9	\$1074
3	\$858	10	\$1110
4	\$894	11	\$1146
5	\$930	12	\$1182
6	\$966	L	\$1062
7	\$1002		

NOTES: See page 142 for arm packs.

HON Recommendation: HIWM2.A.H.M.CU__T.SB - List Price \$790

HOW TO SPECIFY

Select Model Number	Select Arm Type	Select Caster/Glide	Select Back Type	Select Fabric	Select Frame	Select Base
N Armless F Fixed Arms - Black (+ \$65) A Height and Width Adjustable Arms (+ \$75) V All-Adjustable Arms (includes Pivot) (+ \$115) P Fixed Arms - Polished (+ \$150)	H Hard Caster S Soft Caster (+ \$30)	U Upholstered M Mesh	See page 137	T Black	SB Standard Base PA Polished Aluminum (+ \$110)	
HIWM1	A	H	M	CU10	T	SB



Icon Legend on page 15

HIEH1**EXECUTIVE HIGH-BACK**

Pneumatic
Back Height Adjustment
Swivel
Tilt
Tilt Tension
Tilt Lock
Functions: **A, B, E, F, K, L**
(Function Key on pages 16-17)

DIMENSIONS

Depth: 38½
Width: 27
Height: 47½
Seat Depth: 18
Seat Width: 20
Back Width: 20
Back Height: 24¾-27¾
Arm Width: 20
Seat to Floor Height: 16¾-21¼
Usable Seat Depth: 17⅞
Ship Weight: 56
Cube: 16.0
COM: 2.5
Weight Rating: 300 lbs.

FABRIC PRICE CODES

1	\$668	8	\$944
2	\$716	9	\$980
3	\$764	10	\$1016
4	\$800	11	\$1052
5	\$836	12	\$1088
6	\$872	L	\$968
7	\$908		

NOTES: See page 142 for arm packs.

HIEH2**EXECUTIVE HIGH-BACK**

Pneumatic
Back Height Adjustment
Synchro-tilt
Tilt Tension
Seat Glide
Functions:
A, B, D, E, J, A-D, L
(Function Key on pages 16-17)

DIMENSIONS

Depth: 41
Width: 27
Height: 49
Seat Depth: 17-19
Seat Width: 20
Back Width: 19½
Back Height: 24¾-27¾
Arm Width: 20
Seat to Floor Height: 17-21½
Usable Seat Depth: 16½-18
Ship Weight: 61
Cube: 16.0
COM: 2.5
Weight Rating: 300 lbs.

FABRIC PRICE CODES

1	\$742	8	\$1018
2	\$790	9	\$1054
3	\$838	10	\$1090
4	\$874	11	\$1126
5	\$910	12	\$1162
6	\$946	L	\$1042
7	\$982		

NOTES: See page 142 for arm packs.

HIEH3**EXECUTIVE HIGH-BACK**

Pneumatic
Back Height Adjustment
Synchro-tilt
Back Angle Adjustment
Tilt Tension
Seat Glide
Functions:
A, B, D, E, A-D, A-E, L
(Function Key on pages 16-17)

DIMENSIONS

Depth: 45½
Width: 27
Height: 49
Seat Depth: 17-19
Seat Width: 20
Back Width: 19½
Back Height: 24¾-27¾
Arm Width: 20
Seat to Floor Height: 17-21½
Usable Seat Depth: 15¼-17¼
Ship Weight: 65
Cube: 16.0
COM: 2.5
Weight Rating: 300 lbs.

FABRIC PRICE CODES

1	\$787	8	\$1063
2	\$835	9	\$1099
3	\$883	10	\$1135
4	\$919	11	\$1171
5	\$955	12	\$1207
6	\$991	L	\$1087
7	\$1027		

NOTES: See page 142 for arm packs.

HON Recommendation: HIEH1.F.H.U.CU__T.SB - List Price \$733**HOW TO SPECIFY**

Select Model Number	Select Arm Type	Select Caster/Glide	Select Back Type	Select Fabric	Select Frame	Select Base
N Armless F Fixed Arms - Black (+ \$65) A Height and Width Adjustable Arms (+ \$75) V All-Adjustable Arms (includes Pivot) (+ \$115) P Fixed Arms - Polished (+ \$150)	H Hard Caster S Soft Caster (+ \$30)	U Upholstered	See page 137	T Black	SB Standard Base PA Polished Aluminum (+ \$110)	
H I E H 1 .	F .	H .	U .	C U 1 0 .	T .	S B



HITS5



TASK STOOL

Pneumatic Swivel Back Height Adjustment Adjustable Footrest
 Functions: **A, B, E**
 (Function Key on pages 16-17)

DIMENSIONS

Upholstered Back Width:	17½	Adjustable Arms Width:	17-19½
Upholstered Back Height:	18¾-21¾	Fixed Arms Width:	20
Mesh Back Width:	17½	Seat to Floor Height:	23⅝-33⅝
Mesh Back Height:	20¾-23¾	Usable Seat Depth:	15¾
Depth:	27½	Ship Weight (upholstered back):	56 Ⓞ
Width:	27	Ship Weight (mesh back):	51 Ⓞ
Height:	44	Cube (upholstered back):	10.8
Seat Depth:	17	Cube (mesh back):	10.8
Seat Width:	19	COM (upholstered back):	2.0
		COM (mesh back):	1.0
		Weight Rating:	300 lbs.

FABRIC PRICE CODES

1	\$694	8	\$970
2	\$742	9	\$1006
3	\$790	10	\$1042
4	\$826	11	\$1078
5	\$862	12	\$1114
6	\$898	L	—
7	\$934		

NOTES: See page 142 for arm packs.

HIWM8



TASK MID-BACK

Big and Tall
 Pneumatic Swivel-tilt Tilt Tension
 Functions: **A, E, F, K, L**
 (Function Key on pages 16-17)

DIMENSIONS

Depth:	28	Arm Width:	23-25½
Width:	32¼	Seat to Floor Height:	17⅞-20⅜
Height:	43⅞	Usable Seat Depth:	19½
Seat Depth:	19½	Ship Weight:	60
Seat Width:	23½	Cube:	16.0
Back Width:	23½	COM:	3.0
Back Height:	23	Weight Rating:	450 lbs.

FABRIC PRICE CODES

1	\$1278	8	\$1692
2	\$1350	9	\$1746
3	\$1422	10	\$1800
4	\$1476	11	\$1854
5	\$1530	12	\$1908
6	\$1584	L	—
7	\$1638		

NOTES: See page 142 for arm packs.

HON Recommendation: HITS5.A.H.M.CU__T.SB - List Price \$769

HOW TO SPECIFY

Select Model Number	Select Arm Type	Select Caster/Glide	Select Back Type	Select Fabric	Select Frame	Select Base
N Armless F Fixed Arms - Black (+ \$65) A Height and Width Adjustable Arms (+ \$75) V All-Adjustable Arms (includes Pivot) (+ \$115) P Fixed Arms - Polished (+ \$150)	H Hard Caster S Soft Caster (+ \$30) A All Surface Caster (available on model HIWM8 only) <i>H and S caster options not available on model HIWM8</i>	U Upholstered M Mesh <i>Mesh back not available on HIWM8</i>	See page 137	T Black	SB Standard Base	

HITS5 . A . H . M . CU10 . T . SB

HI2ATA



ADJUSTABLE ARMS

Height and Width
Functions: **S**
(Function Key on pages 16-17)

DIMENSIONS

Adjustable Arms Width: 17-19½
Height from Seat: 8-11
Ship Weight: 8 **S**
Cube: 1.0

LIST PRICE

\$123

HI2AAA

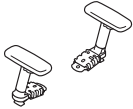

ALL-ADJUSTABLE ARMS

Height, Width, Depth and Pivot

DIMENSIONS

Adjustable Arms Width: 17-20
Height from Seat: 7-11
Ship Weight: 8 **S**
Cube: 1.0

LIST PRICE

\$166

HI2FHA

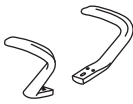

FIXED HEIGHT ARMS

DIMENSIONS

Arm Width: 20
Height from Seat: 9½
Ship Weight: 7 **S**
Cube: 1.0

LIST PRICE

\$113

HIPAA

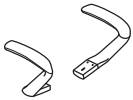

POLISHED ALUMINUM ARMS

Fixed Height

DIMENSIONS

Arm Width: 20
Height from Seat: 9½
Ship Weight: 10 **S**
Cube: 1.0

LIST PRICE

\$188

HSCASTER

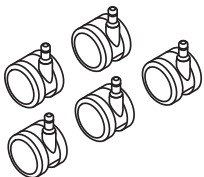

SET OF 5 SOFT CASTERS

DIMENSIONS

Size: 60mm
Ship Weight: 2 **S**
Cube: 0.1

LIST PRICE

\$50

! Available in Black finish only, no specification needed.

OPEN MARKET



HOW TO SPECIFY

Select Model Number	Select Frame
	T Black TI Titanium
HI2ATA.	T

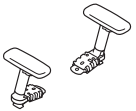
IGNITION® 2.0 Options

ARM STYLE	CODE	DESCRIPTION	PRICE
	N	Armless	+\$0
	F	Fixed Arms	+\$65
	A	Height and Width Adjustable Arms	+\$75
	V	All-Adjustable Arms (includes Pivot)	+\$115
	P	Fixed Polished Aluminum Arms	+\$150

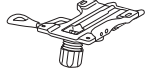
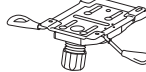
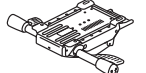
CASTERS	CODE	DESCRIPTION	PRICE
	H	Hard Caster	+\$0
	S	Soft Caster	+\$30
	R	Roll Control Caster	+\$50

MECHANISM	CODE	DESCRIPTION	PRICE
	Y0	Synchro-Tilt A, E, J, K, L	+\$0
	Y1	Synchro-Tilt w/ Seat Slider A, D, E, J, K, L	+\$20
	Y2	Advanced Synchro-Tilt A, D, E, J, L, A-D	+\$65
	Y3	Synchro-Tilt with Independent Back Angle A, D, E, J, L, A-E	+\$105

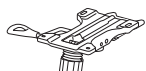
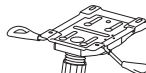

	S0	Limited Recline Synchro-Tilt A, E, J, K, L	+\$0
	S1	Limited Recline Synchro-Tilt w/ Seat Slider A, D, E, J, K, L	+\$20

**Only available on HITSM*

LUMBAR	CODE	DESCRIPTION	PRICE
	NL	No Lumbar	+\$0
	AL	Adjustable Lumbar	+\$30

**Adjustable Lumbar not available on CAL 133 (FC) models*

BACK STYLE	CODE	DESCRIPTION	PRICE
<i>4-Way Stretch mesh back options:</i>			
	IM	Black	+\$0
	IF	Fog	+\$0
	IC	Charcoal	+\$0
	IH	Chai	+\$0
	IY	Navy	+\$0
<i>ReActiv® back options:</i>			
	OS	Charcoal	+\$0
	TI	Titanium	+\$0

BASE	CODE	DESCRIPTION	PRICE
	SB	Standard Base	+\$0
	PA	Polished Aluminum	+\$110

FRAME	CODE	DESCRIPTION	PRICE
	T	Black Frame	+\$0
	TI	Titanium Frame	+\$35

IGNITION® 2.0

Dimensions

TASK DIMENSIONS

MODEL		HIWMM, HIWMRA, HIWMU, & HIWMUL	HITLM & HITLRA	HITSM & HITSRA	HITLMKD & HITLRAKD	HIWMMKD, HIWMRAKD, HIWMUKD, & HIWMULKD
Overall Width Armless		21	20	20	20	21
Overall Width with Arms	A	27	26	26	26	27
Overall Depth		24	22	22	22	24
Overall Height	S0/S1	-	-	52½	-	-
	Y0/Y1	43¾	40½	-	40½	43¾
	Y2	44½	41¼	-	-	-
	Y3	44½	41¼	-	-	-
	W5	45¼	41½	-	-	-
Seat Width		20	18½	18½	18½	20
Seat Depth		18¾	17¾	17¾	17¾	18¾
Usable Seat Depth	S0	-	-	16¾	-	-
	S1	-	-	15½-16⅞	-	-
	Y0	17¾	16¾	-	16¾	17¾
	Y1	17½-19½	15½-17½	-	15½-17½	17½-19½
	Y2	16¼-19¼	15¾-18½	-	-	-
	Y3	16½-19½	16¼-18¾	-	-	-
	W5	17½-20	16⅝-18¾	-	-	-
Seat Height	S0/S1	-	-	22⅞-31¾	-	-
	Y0/Y1	16⅝-21¼	16¾-21¼	-	16¾-21¼	16⅝-21¼
	Y2	17⅞-21½	17⅞-21½	-	-	-
	Y3	17½-21½	17¾-21¾	-	-	-
	W5	16¾-21⅞	16¾-21½	-	-	-
Back Width		19	17½	17½	17½	19
Back Height		23	19	19	19	23
Ship Weight Armless	S0	-	-	44 Ⓢ	-	-
	S1	-	-	46 Ⓢ	-	-
	Y0	38 Ⓢ	38 Ⓢ	-	38 Ⓢ	38 Ⓢ
	Y1	38 Ⓢ	38 Ⓢ	-	38 Ⓢ	38 Ⓢ
	Y2	42 Ⓢ	42 Ⓢ	-	-	-
	Y3	46 Ⓢ	45 Ⓢ	-	-	-
	W5	45 Ⓢ	44 Ⓢ	-	-	-
Ship Weight with Arms	S0	-	-	51 Ⓢ	-	-
	S1	-	-	53 Ⓢ	-	-
	Y0	45 Ⓢ	45 Ⓢ	-	45 Ⓢ	45 Ⓢ
	Y1	45 Ⓢ	45 Ⓢ	-	45 Ⓢ	45 Ⓢ
	Y2	49 Ⓢ	49 Ⓢ	-	-	-
	Y3	53 Ⓢ	52 Ⓢ	-	-	-
	W5	52 Ⓢ	51 Ⓢ	-	-	-
Width Between Arms	F	20¼	19	19	19	20¼
	P	20¼	19	19	19	20¼
	A	18-20½	17-19½	17-19½	17-19½	18-20½
	V	12½-27½	11½-26½	11½-26½	11½-26½	12½-27½
Cube		10.8	10.8	10.8	5.6	6.3
Cube with Y3 Control		12.0	12.0	-	-	-
COM		1.0	1.0	1.0	-	-
Weight Capacity		300 lbs	300 lbs	300 lbs	300 lbs	300 lbs



Icon Legend on page 15

IGNITION® 2.0

HITLM

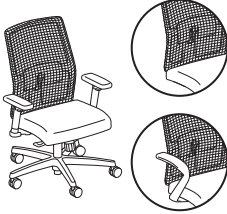

TASK LOW-BACK

- 4-Way Stretch Mesh Back**
- Pneumatic
- Swivel
- Synchro-tilt
- Tilt Tension
- Tilt Lock
- Optional Lumbar Support

DIMENSIONS

Depth:	22	Width (with arms):	26
Height:	40½	Width (armless):	20
Seat Depth:	16	Cube:	10.8
Seat Width:	18½	COM:	1.0
Back Width:	17½	Weight Rating:	300 lbs.
Back Height:	19		

FABRIC PRICE CODES

1	\$499	8	\$637
2	\$523	9	\$655
3	\$547	10	\$673
4	\$565	11	\$691
5	\$583	12	\$709
6	\$601	L	\$699
7	\$619		

! See page 144 for additional specifications and dimensions.

HIWMM

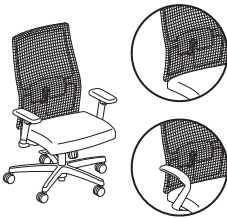

TASK MID-BACK

- 4-Way Stretch Mesh Back**
- Pneumatic
- Swivel
- Synchro-tilt
- Tilt Tension
- Tilt Lock
- Optional Lumbar Support

DIMENSIONS

Depth:	24	Width (with arms):	27
Height:	43¾	Width (armless):	21
Seat Depth:	17¾	Cube:	10.8
Seat Width:	20	COM:	1.0
Back Width:	19	Weight Rating:	300 lbs.
Back Height:	23		

FABRIC PRICE CODES

1	\$545	8	\$683
2	\$569	9	\$701
3	\$593	10	\$719
4	\$611	11	\$737
5	\$629	12	\$755
6	\$647	L	\$745
7	\$665		

! See page 144 for additional specifications and dimensions.

HITSM

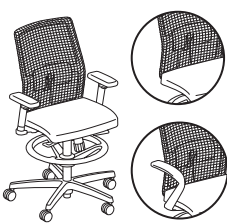

TASK LOW-BACK STOOL

- 4-Way Stretch Mesh Back**
- Pneumatic
- Swivel
- Synchro-tilt
- Tilt Tension
- Tilt Lock
- Optional Lumbar Support

DIMENSIONS

Depth:	22	Width (with arms):	26
Height:	52½	Width (armless):	20
Seat Depth:	16	Cube:	10.8
Seat Width:	18½	COM:	1.0
Back Width:	17½	Weight Rating:	300 lbs.
Back Height:	19		

FABRIC PRICE CODES

1	\$596	8	\$734
2	\$620	9	\$752
3	\$644	10	\$770
4	\$662	11	\$788
5	\$680	12	\$806
6	\$698	L	\$796
7	\$716		

! See page 144 for additional specifications and dimensions.

! Not available in Polished Aluminum Base.

HON Recommendation: HIWMM.Y2.A.H.IM.CU__AL.SB.T - List Price \$715

HOW TO SPECIFY

Select Model Number	Select Control Type	Select Arm Type	Select Caster	Select Mesh	Select Fabric	Select Lumbar	Select Base	Select Frame
Y0 Synchro-Tilt	N Armless	H Hard Caster	IM Black	See page 137	NL No Lumbar	SB Standard Base	T Black	
Y1 Synchro-Tilt w/ Seat Slider (+ \$20)	A Height and Width Adjustable Arms (+ \$75)	S Soft Caster (+ \$30)	IF Fog		AL Adjustable Lumbar (+ \$30)	PA Polished Aluminum (+ \$110)	TI Titanium (+ \$35)	
Y2 Advanced Synchro-Tilt (+ \$65)	V All-Adjustable Arms (includes pivot) (+ \$115)	R Roll Control Caster (+ \$50)	IC Charcoal					
Y3 Synchro-Tilt with Independent Back Angle (+ \$105)	F Fixed Arms (+ \$65)		IH Chai					
S0 Limited Recline Synchro-Tilt (for HITSM only)	P Fixed Arms - Polished (+ \$150)		IY Navy					
S1 Limited Recline Synchro-Tilt w/ Seat Slider (+ \$20 for HITSM only)								

HITLM . Y2 . A . H . IM . CU10 . AL . SB . T

IGNITION® 2.0

GSA SIN 33721



Icon Legend on page 15

HITLMKD



TASK LOW-BACK

4-Way Stretch Mesh Back
 Pneumatic
 Swivel
 Synchro-tilt
 Tilt Tension
 Tilt Lock
 Optional Lumbar Support

DIMENSIONS

Depth:	22	Back Height:	19
Height:	40½	Width (with arms):	26
Seat Depth:	16	Width (armless):	20
Seat Width:	18½	Cube:	5.6
Back Width:	17½	Weight Rating:	300 lbs.

FABRIC PRICE CODES

1 \$459
2 \$483
3 \$507

! See page 144 for additional specifications and dimensions.

HIWMMKD



TASK MID-BACK

4-Way Stretch Mesh Back
 Pneumatic
 Swivel
 Synchro-tilt
 Tilt Tension
 Tilt Lock
 Optional Lumbar Support

DIMENSIONS

Depth:	24	Back Height:	23
Height:	43¾	Width (with arms):	27
Seat Depth:	17¾	Width (armless):	21
Seat Width:	20	Cube:	6.3
Back Width:	19	Weight Rating:	300 lbs.

FABRIC PRICE CODES

1 \$505
2 \$529
3 \$553

! See page 144 for additional specifications and dimensions.

HON Recommendation: HIWMMKD.Y2.A.H.IM.CU__AL.SB.T - List Price \$675

HOW TO SPECIFY

Select Model Number	Select Control Type	Select Arm Type	Select Caster	Select Mesh	Select Fabric	Select Lumbar	Select Base	Select Frame
	Y1 Synchro-Tilt w/ Seat Slider (+ \$20) Y2 Advanced Synchro-Tilt (+ \$65)	A Height and Width Adjustable Arms (+ \$75)	H Hard Caster	IM Black IF Fog IC Charcoal	See page 137	NL No Lumbar AL Adjustable Lumbar (+ \$30)	SB Standard Base	T Black T1 Titanium (+ \$35)
H I W M M K D .	Y 2 .	A .	H .	I M .	C U I O .	A L .	S B .	T .



Icon Legend on page 15

IGNITION® 2.0

ReActiv®

HITLRA

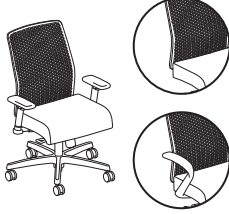

TASK LOW-BACK

- ReActiv® Back**
- Pneumatic
- Swivel
- Synchro-tilt
- Tilt Tension
- Tilt Lock
- Optional Lumbar Support

DIMENSIONS

Depth:	22	Width (with arms):	26
Height:	40½	Width (armless):	20
Seat Depth:	16	Cube:	10.8
Seat Width:	18½	COM:	1.0
Back Width:	17½	Weight Rating:	300 lbs.
Back Height:	19		

FABRIC PRICE CODES

1	\$529	8	\$667
2	\$553	9	\$685
3	\$577	10	\$703
4	\$595	11	\$721
5	\$613	12	\$739
6	\$631	L	\$729
7	\$649		

See page 144 for all other control specifications.

HIWMRA

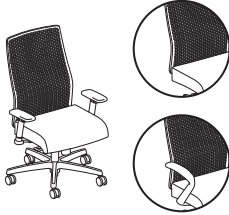

TASK MID-BACK

- ReActiv® Back**
- Pneumatic
- Swivel
- Synchro-tilt
- Tilt Tension
- Tilt Lock
- Optional Lumbar Support

DIMENSIONS

Depth:	24	Width (with arms):	27
Height:	43¾	Width (armless):	21
Seat Depth:	17¾	Cube:	10.8
Seat Width:	20	COM:	1.0
Back Width:	19	Weight Rating:	300 lbs.
Back Height:	23		

FABRIC PRICE CODES

1	\$575	8	\$713
2	\$599	9	\$731
3	\$623	10	\$749
4	\$641	11	\$767
5	\$659	12	\$785
6	\$677	L	\$775
7	\$695		

See page 144 for all other control specifications.

HITSRA

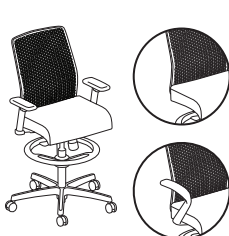

TASK LOW-BACK STOOL

- ReActiv® Back**
- Pneumatic
- Swivel
- Synchro-tilt
- Tilt Tension
- Tilt Lock
- Optional Lumbar Support

DIMENSIONS

Depth:	22	Width (with arms):	26
Height:	52½	Width (armless):	20
Seat Depth:	16	Cube:	10.8
Seat Width:	18½	COM:	1.0
Back Width:	17½	Weight Rating:	300 lbs.
Back Height:	19		

FABRIC PRICE CODES

1	\$626	8	\$764
2	\$650	9	\$782
3	\$674	10	\$800
4	\$692	11	\$818
5	\$710	12	\$836
6	\$728	L	\$826
7	\$746		

See page 144 for all other control specifications.

Not available in Polished Aluminum Base.

HON Recommendation: HIWMRA.Y2.A.H.___CU__AL.SB.T - List Price \$745

HOW TO SPECIFY

Select Model Number	Select Control Type	Select Arm Type	Select Caster	Select Back Color	Select Fabric	Select Lumbar	Select Base	Select Frame
	Y0 Synchro-Tilt Y1 Synchro-Tilt w/ Seat Slider (+ \$20) Y2 Advanced Synchro-Tilt (+ \$65) Y3 Synchro-Tilt with Independent Back Angle (+ \$105) S0 Limited Synchro-Tilt (for HITSRA only) S1 Limited Synchro-Tilt w/ Seat Slider (+ \$20 for HITSRA only) Specify S0 or S1 for HITSRA model ONLY	N Armless A Height and Width Adjustable Arms (+ \$75) V All-Adjustable Arms (includes pivot) (+ \$115) F Fixed Arms (+ \$65) P Fixed Arms - Polished (+ \$150)	H Hard Caster S Soft Caster (+ \$30) R Roll Control Caster (+ \$50)	OS Charcoal ReActiv® TI Titanium ReActiv®	See page 137	NL No Lumbar AL Adjustable Lumbar (+ \$30)	SB Standard Base PA Polished Aluminum (+ \$110)	T Black TI Titanium (+ \$35)
HITLRA	Y2	A	H	OS	CU10	AL	SB	T

IGNITION® 2.0

ReActiv®

OPEN MARKET



Icon Legend on page 15

HITLRAKD

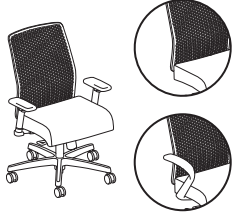

TASK LOW-BACK

ReActiv® Back
 Pneumatic
 Swivel
 Synchro-tilt
 Tilt Tension
 Tilt Lock
 Optional Lumbar Support

DIMENSIONS

Depth: 22
 Height: 40½
 Seat Depth: 16
 Seat Width: 18½
 Back Width: 17½
 Back Height: 25½
 Width (with arms): 26
 Width (armless): 20
 Cube: 5.6
 Weight Rating: 300 lbs.

FABRIC PRICE CODES

1 \$489
2 \$513
3 \$537

! See page 144 for all other control specifications.

HIWMRAKD

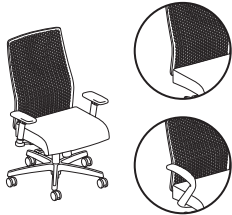

TASK MID-BACK

ReActiv® Back
 Pneumatic
 Swivel
 Synchro-tilt
 Tilt Tension
 Tilt Lock
 Optional Lumbar Support

DIMENSIONS

Depth: 24
 Height: 43¾
 Seat Depth: 17¾
 Seat Width: 20
 Back Width: 19
 Back Height: 29
 Width (with arms): 27
 Width (armless): 21
 Cube: 6.3
 Weight Rating: 300 lbs.

FABRIC PRICE CODES

1 \$535
2 \$559
3 \$583

! See page 144 for all other control specifications.

HON Recommendation: HIWMRAKD.Y2.A.H.__.CU__AL.SB.T - List Price \$705

HOW TO SPECIFY

Select Model Number	Select Control Type	Select Arm Type	Select Caster	Select Back Color	Select Fabric	Select Lumbar	Select Base	Select Frame
	Y1 Synchro-Tilt w/ Seat Slider (+ \$20) Y2 Advanced Synchro-Tilt (+ \$65)	N Armless A Height and Width Adjustable Arms (+ \$75)	H Hard Caster	OS Charcoal ReActiv® TI Titanium ReActiv®	See page 137	NL No Lumbar AL Adjustable Lumbar (+ \$30)	SB Standard Base	T Black TI Titanium (+ \$35)
H I W M R A K D .	Y 2 .	A .	H .	O S .	C U 1 0 .	A L .	S B .	T



Icon Legend on page 15

IGNITION® 2.0 Upholstered

HIWMU



TASK MID-BACK

- Upholstered Back**
- Pneumatic
- Swivel
- Synchro-tilt
- Tilt Tension
- Tilt Lock

DIMENSIONS

Depth:	24	Width (with arms):	27
Height:	43¾	Width (armless):	21
Seat Depth:	17¾	Cube:	10.8
Seat Width:	20	COM:	3.0
Back Width:	19	Weight Rating:	300 lbs.
Back Height:	23		

FABRIC PRICE CODES

1	\$545	7	\$845
2	\$605	8	\$890
3	\$665	9	\$935
4	\$710	10	\$980
5	\$755	11	\$1025
6	\$800	12	\$1070

! See page 144 for additional specifications and dimensions.

HIWMUL

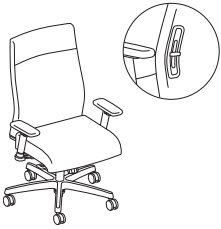

TASK MID-BACK WITH ADJUSTABLE LUMBAR

- Upholstered Back**
- Pneumatic
- Swivel
- Synchro-tilt
- Tilt Tension
- Tilt Lock
- Adjustable Lumbar

DIMENSIONS

Depth:	24½	Width (with arms):	27
Height:	43¾	Width (armless):	21
Seat Depth:	17¾	Cube:	10.8
Seat Width:	20	COM:	3.0
Back Width:	19	Weight Rating:	300 lbs.
Back Height:	23		

FABRIC PRICE CODES

1	\$575	7	\$875
2	\$635	8	\$920
3	\$695	9	\$965
4	\$740	10	\$1010
5	\$785	11	\$1055
6	\$830	12	\$1100

! See page 144 for additional specifications and dimensions.

HON Recommendation: HIWMU.Y2.A.H.CU__NL.SB.T - List Price \$685

HOW TO SPECIFY

Select Model Number	Select Control Type	Select Arm Type	Select Caster	Select Fabric	Select Lumbar	Select Base	Select Frame
Y0 Synchro-Tilt Y1 Synchro-Tilt w/ Seat Slider (+ \$20) Y2 Advanced Synchro-Tilt (+ \$65) Y3 Synchro-Tilt with Independent Back Angle (+ \$105)	N Armless A Height and Width Adjustable Arms (+ \$75) V All-Adjustable Arms (+ \$115) F Fixed Arms (+ \$65) P Fixed Arms - Polished (+ \$150)	H Hard Caster S Soft Caster (+ \$30) R Roll Control Caster (+ \$50)	See page 137	NL No Lumbar <i>Specify for model HIWMU only</i> AL Adjustable Lumbar <i>Specify for model HIWMUL only</i>	SB Standard Base PA Polished Aluminum (+ \$110)	T Black TI Titanium (+ \$35)	
HIWMU	Y2	A	H	CU10	NL	SB	T

IGNITION® 2.0 Upholstered

GSA SIN 33721



Icon Legend on page 15

HIWMUKD



TASK MID-BACK

Upholstered Back
Pneumatic
Swivel
Synchro-tilt
Tilt Tension
Tilt Lock

DIMENSIONS

Depth:	24	Back Height:	23
Height:	43¾	Width (with arms):	27
Seat Depth:	17¾	Width (armless):	21
Seat Width:	20	Cube:	6.3
Back Width:	19	Weight Rating:	300 lbs.

FABRIC PRICE CODES

1	\$505
2	\$565
3	\$625

! See page 144 for additional specifications and dimensions.

HIWMULKD

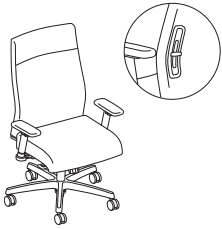

TASK MID-BACK WITH ADJUSTABLE LUMBAR

Upholstered Back
Pneumatic
Swivel
Synchro-tilt
Tilt Tension
Tilt Lock
Adjustable Lumbar

DIMENSIONS

Depth:	24½	Back Height:	23
Height:	43¾	Width (with arms):	27
Seat Depth:	17¾	Width (armless):	21
Seat Width:	20	Cube:	6.3
Back Width:	19	Weight Rating:	300 lbs.

FABRIC PRICE CODES

1	\$535
2	\$595
3	\$625

! See page 144 for additional specifications and dimensions.

HON Recommendation: HIWMUKD.Y2.A.H.CU__NL.SB.T - List Price \$645

HOW TO SPECIFY

Select Model Number	Select Control Type	Select Arm Type	Select Caster	Select Fabric	Select Lumbar	Select Base	Select Frame
HIWMUKD	<p>Y1 Synchro-Tilt w/ Seat Slider (+ \$20)</p> <p>Y2 Advanced Synchro-Tilt (+ \$65)</p>	<p>N Armless</p> <p>A Height and Width Adjustable Arms (+ \$75)</p>	H Hard Caster	See page 137	<p>NL No Lumbar <i>Specify for model HIWMUKD only</i></p> <p>AL Adjustable Lumbar <i>Specify for model HIWMULKD only</i></p>	SB Standard Base	<p>T Black (+ \$35)</p> <p>TI Titanium (+ \$35)</p>
HIWMUKD	Y2	A	H	CU10	NL	SB	T



Icon Legend on page 15

HIGB1

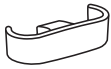

GANGING BRACKET

- For Armless Guest Chairs
- 24 per package

DIMENSIONS

Ship Weight: 1 **Ⓢ**
Cube: 0.1

LIST PRICE

\$81

HI2ATA



ADJUSTABLE ARMS

Height and Width
Functions: **S**
(Function Key on pages 16-17)

DIMENSIONS

Adjustable Arms Width: 17-19½
Height from Seat: 8-11
Ship Weight: 8 **Ⓢ**
Cube: 1.0

LIST PRICE

\$123

HI2AAA

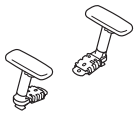

ALL-ADJUSTABLE ARMS

Height, Width, Depth and Pivot

DIMENSIONS

Adjustable Arms Width: 17-20
Height from Seat: 7-11
Ship Weight: 8 **Ⓢ**
Cube: 1.0

LIST PRICE

\$166

HI2FHA



FIXED HEIGHT ARMS

DIMENSIONS

Arm Width: 20
Height from Seat: 9½
Ship Weight: 7 **Ⓢ**
Cube: 1.0

LIST PRICE

\$113

HILMBR

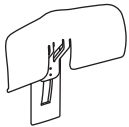

LUMBAR SUPPORT

DIMENSIONS

Ship Weight: 8 **Ⓢ**
Cube: 1.0

LIST PRICE

\$32

HIPAA

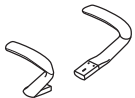

POLISHED ALUMINUM ARMS

Fixed Height

DIMENSIONS

Arm Width: 20
Height from Seat: 9½
Ship Weight: 10 **Ⓢ**
Cube: 1.0

LIST PRICE

\$188

HSCASTER

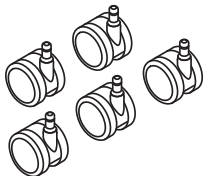

SET OF 5 SOFT CASTERS

DIMENSIONS

Size: 60mm
Ship Weight: 2 **Ⓢ**
Cube: 0.1

LIST PRICE

\$50

ⓘ Available in Black finish only, no specification needed.

OPEN MARKET

HOW TO SPECIFY

<p>Select Model Number</p>	<p>Select Frame</p> <p>T Black TI Titanium</p> <p><i>Not specified for models HIGB1 or HIPAA</i></p>
<p>H I 2 A T A .</p>	<p>T</p>

IGNITION®

Guest Chair Options

ARM STYLE	CODE	DESCRIPTION	PRICE
	N	Armless	+\$0
	F	Fixed Arms	+\$30

BACK STYLE	CODE	DESCRIPTION	PRICE
U		Upholstered	+\$0
IM		Black	+\$0
IF		Fog	+\$0
IC		Charcoal	+\$0
IH		Chai	+\$0
IY		Navy	+\$0

CASTERS/ GLIDE	CODE	DESCRIPTION	PRICE
	H	Hard Caster	+\$0
	S	Soft Caster	+\$20
	E	Glide	+\$0

Casters only available on HIGS6

FRAME	CODE	DESCRIPTION	PRICE
T		Black	+\$0
BLCK		Textured Black	+\$0
PLAT		Textured Platinum Metallic	+\$0
PR8T		Textured Silver	+\$35

By selecting PR8T, unit will be produced with titanium colored arm caps, back frame & glides



HIGCL



GUEST CHAIR

Fixed Arms
Glides

DIMENSIONS

Depth:	24	Arm Width:	19¼
Width:	23	Seat to Floor Height:	18½
Height:	35½	Usable Seat Depth:	16¾
Seat Depth:	18	Ship Weight:	42
Seat Width:	19½	Cube:	15.2
Back Width:	19½	COM:	2.0
Back Height:	20	Weight Rating:	300 lbs.

FABRIC PRICE CODES

1	\$459	8	\$735
2	\$507	9	\$771
3	\$555	10	\$807
4	\$591	11	\$843
5	\$627	12	\$879
6	\$663	L	\$759
7	\$699		

HON Recommendation: HIGCL.E.U.CU__T - List Price \$459

HOW TO SPECIFY

Select Model Number HIGCL	Select Glide E Glide E	Select Back Type U Upholstered U	Select Fabric See page 137 CU10	Select Frame T Black BLCK Textured Black PLAT Textured Platinum Metallic T
---	-------------------------------------	---	--	---

HIB50

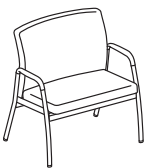

BARIATRIC LOUNGE

Fixed Arms
Glides

DIMENSIONS

Depth:	25½	Arm Width:	30
Width:	33¾	Seat to Floor Height:	20
Height:	35¾	Usable Seat Depth:	18¾
Seat Depth:	18¾	Ship Weight:	70
Seat Width:	29¾	Cube:	27.5
Back Width:	29	COM:	2.5
Back Height:	19¼	Weight Rating:	500 lbs.

FABRIC PRICE CODES

1	\$1339	8	\$1684
2	\$1399	9	\$1729
3	\$1459	10	\$1774
4	\$1504	11	\$1819
5	\$1549	12	\$1864
6	\$1594	L	—
7	\$1639		

HOW TO SPECIFY

Select Model Number HIB50	Select Arm Type F Fixed Arms F	Select Glide E Glide E	Select Back Type U Upholstered U	Select Fabric See page 137 CU10	Select Frame T Black BLCK Textured Black PLAT Textured Platinum Metallic T
---	---	-------------------------------------	---	--	---



HIGS6

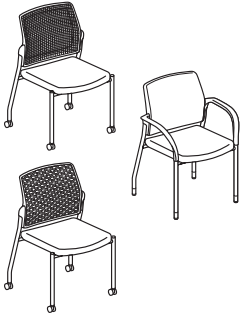

MULTI-PURPOSE

Four Legs

DIMENSIONS

Depth:	21 ³ / ₄	Seat to Floor Height:	18 ³ / ₈
Width:	25	Usable Seat Depth:	17 ³ / ₈
Height:	33 ¹ / ₂	Ship Weight:	28
Seat Depth:	17 ³ / ₈	Cube:	15.1
Seat Width:	18 ³ / ₄	COM (upholstered back):	1.5
Back Width:	18 ¹ / ₄	COM (mesh/ReActiv® back):	1.0
Back Height:	18 ¹ / ₈	Weight Rating:	300 lbs.
Arm Width:	21 ¹ / ₂		

FABRIC PRICE CODES

1	\$436	8	\$643
2	\$472	9	\$670
3	\$508	10	\$697
4	\$535	11	\$724
5	\$562	12	\$751
6	\$589	L	\$736
7	\$616		

NOTES: Stacks 4-high.

- ! Ganging brackets work with armless Guest/Multi-purpose models only.
- ! ReActiv® back option not available on FC models.

HISB6



MULTI-PURPOSE

Sled Base

DIMENSIONS

Depth:	23 ³ / ₄	Seat to Floor Height:	18 ³ / ₈
Width:	25	Usable Seat Depth:	17 ³ / ₈
Height:	33 ¹ / ₂	Ship Weight:	30
Seat Depth:	17 ³ / ₈	Cube:	15.1
Seat Width:	18 ³ / ₄	COM (upholstered back):	1.5
Back Width:	18 ¹ / ₄	COM (mesh/ReActiv® back):	1.0
Back Height:	18 ¹ / ₈	Weight Rating:	300 lbs.
Arm Width:	21 ¹ / ₂		

FABRIC PRICE CODES

1	\$436	8	\$643
2	\$472	9	\$670
3	\$508	10	\$697
4	\$535	11	\$724
5	\$562	12	\$751
6	\$589	L	\$736
7	\$616		

- ! Ganging brackets work with armless Guest/Multi-purpose models only.
- ! ReActiv® back option not available on FC models.

HICS7

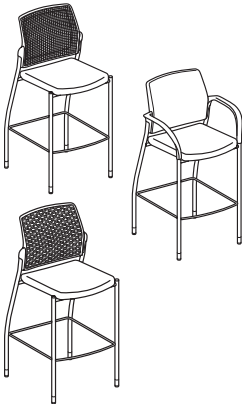

CAFÉ-HEIGHT STOOL

Four Legs

DIMENSIONS

Depth:	23	Seat to Floor Height:	31
Width:	25	Usable Seat Depth:	17 ³ / ₈
Height:	46 ¹ / ₂	Ship Weight:	37
Seat Depth:	17 ³ / ₈	Cube:	21.8
Seat Width:	18 ³ / ₄	COM (upholstered back):	1.5
Back Width:	18 ¹ / ₄	COM (mesh/ReActiv® back):	1.0
Back Height:	18 ¹ / ₈	Weight Rating:	300 lbs.
Arm Width:	21 ¹ / ₂		

FABRIC PRICE CODES

1	\$551	8	\$758
2	\$587	9	\$785
3	\$623	10	\$812
4	\$650	11	\$839
5	\$677	12	\$866
6	\$704	L	\$851
7	\$731		

- ! Ganging brackets work with armless Guest/Multi-purpose models only.
- ! ReActiv® back option not available on FC models.

HON Recommendation: HIGS6.F.H.IM.CU__T - List Price \$466

HOW TO SPECIFY

Select Model Number	Select Arm Type	Select Glide	Select Back Type	Select Fabric	Select Frame
F N	F Fixed Arms (+ \$30) N Armless	E Glide H Hard Caster S Soft Caster (+ \$20) <i>Casters available on HIGS6 only</i>	U Upholstered IM Black IF Fog IC Charcoal IH Chai IY Navy OS Charcoal ReActiv® (+ \$30) TI Titanium ReActiv® (+ \$30)	See page 137	T Black BLCK Textured Black PLAT Textured Platinum Metallic PR8T Textured Silver (+ \$35)
HIGS6.	F.	H.	IM.	CU10.	T



HIGS6DF

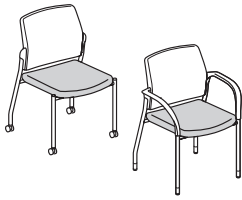

MULTI-PURPOSE

Dual Fabric
Four Legs

DIMENSIONS

Depth:	21 ³ / ₄	Arm Width:	21 ¹ / ₂
Width:	25	Seat to Floor Height:	18 ³ / ₈
Height:	33 ¹ / ₂	Usable Seat Depth:	17 ³ / ₈
Seat Depth:	17 ³ / ₈	Ship Weight (upholstered back):	28
Seat Width:	18 ³ / ₄	Cube (upholstered back):	15.1
Back Width:	18 ¹ / ₄	COM (back):	0.75
Back Height:	18 ¹ / ₈	COM (seat):	0.75
		Weight Rating:	300 lbs.

FABRIC PRICE CODES

1	\$511	
<i>Add to Base Price Above</i>		
	Back	Seat
2	\$18	\$18
3	\$36	\$36
4	\$50	\$50
5	\$63	\$63
6	\$77	\$77
7	\$90	\$90
8	\$104	\$104
9	\$117	\$117
10	\$131	\$131
11	\$144	\$144
12	\$158	\$158
L	\$150	\$150

NOTES: Stacks 4-high.

! Ganging brackets work with armless Guest/Multi-purpose models only.

HISB6DF

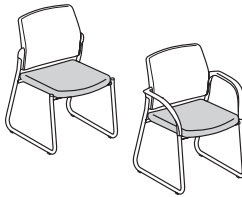

MULTI-PURPOSE

Dual Fabric
Sled Base

DIMENSIONS

Depth:	23 ³ / ₄	Arm Width:	21 ¹ / ₂
Width:	25	Seat to Floor Height:	18 ³ / ₈
Height:	33 ¹ / ₂	Usable Seat Depth:	17 ³ / ₈
Seat Depth:	17 ³ / ₈	Ship Weight (upholstered back):	30
Seat Width:	18 ³ / ₄	Cube (upholstered back):	15.1
Back Width:	18 ¹ / ₄	COM (back):	0.75
Back Height:	18 ¹ / ₈	COM (seat):	0.75
		Weight Rating:	300 lbs.

FABRIC PRICE CODES

1	\$511	
<i>Add to Base Price Above</i>		
	Back	Seat
2	\$18	\$18
3	\$36	\$36
4	\$50	\$50
5	\$63	\$63
6	\$77	\$77
7	\$90	\$90
8	\$104	\$104
9	\$117	\$117
10	\$131	\$131
11	\$144	\$144
12	\$158	\$158
L	\$150	\$150

! Ganging brackets work with armless Guest/Multi-purpose models only.

HON Recommendation: HIGS6DF.F.H.U.CU__UR__.T - List Price \$541

HOW TO SPECIFY

<p>Select Model Number</p> <p>HIGS6DF</p>	<p>Select Arm Type</p> <p>F Fixed Arms (+ \$30) N Armless</p> <p>F</p>	<p>Select Glide</p> <p>E Glide H Hard Caster S Soft Caster (+ \$20) <i>Casters available on HIGS6DF only</i></p> <p>H</p>	<p>Select Back Type</p> <p>U Upholstered</p> <p>U</p>	<p>Select Back Fabric</p> <p>See page 137</p> <p>CU10</p>	<p>Select Seat Fabric</p> <p>See page 137</p> <p>UR10</p>	<p>Select Frame</p> <p>T Black BLCK Textured Black PLAT Textured Platinum Metallic PR8T Textured Silver (+ \$35)</p> <p>T</p>
--	---	---	---	--	--	--



Icon Legend on page 15

HICS7DF



CAFÉ-HEIGHT STOOL

Dual Fabric
Four Legs

DIMENSIONS

Depth:	23	Arm Width:	21½
Width:	25	Seat to Floor Height:	31
Height:	46½	Usable Seat Depth:	17¾
Seat Depth:	17¾	Ship Weight (upholstered back):	37
Seat Width:	18¾	Cube (upholstered back):	21.8
Back Width:	18¼	COM (back):	0.75
Back Height:	18½	COM (seat):	0.75
		Weight Rating:	300 lbs.

FABRIC PRICE CODES

1 \$626

Add to Base Price Above

	Back	Seat
2	\$18	\$18
3	\$36	\$36
4	\$50	\$50
5	\$63	\$63
6	\$77	\$77
7	\$90	\$90
8	\$104	\$104
9	\$117	\$117
10	\$131	\$131
11	\$144	\$144
12	\$158	\$158
L	\$150	\$150

! Ganging brackets work with armless Guest/Multi-purpose models only.

HIGB1



GANGING BRACKET

- For Armless Guest Chairs
- 24 per package

DIMENSIONS

Ship Weight:	1 Ⓢ
Cube:	0.1

LIST PRICE

\$81

HON Recommendation: HICS7DF.F.H.U.CU__UR__.T - List Price \$656

HOW TO SPECIFY

Select Model Number	Select Arm Type	Select Glide	Select Back Type	Select Back Fabric	Select Seat Fabric	Select Frame
F	F Fixed Arms (+ \$30) N Armless	E Glide H Hard Caster S Soft Caster (+ \$20) <i>Casters available on HIGS6DF only</i>	U Upholstered	See page 137	See page 137	T Black BLCK Textured Black PLAT Textured Platinum Metallic PR8T Textured Silver (+ \$35)
HICS7DF	F	H	U	CU10	UR10	T



INSTIGATE™ Mesh Guest Chairs

HVL508



GUEST CHAIR

Leg Base
Armless
Stacks up to Four High

DIMENSIONS

Depth:	22¼	Back Height:	19
Width:	24	Seat to Floor Height:	18¾
Height:	35¾	Usable Seat Depth:	17½
Seat Depth:	17½	Ship Weight:	18.8 Ⓢ
Seat Width:	18½	Cube:	3.1
Back Width:	17½	Weight Rating:	250 lbs.

PRICE CODE

Fabric **\$217**

NOTES: Mesh back. Black fabric seat. Double cross bar frame increases strength and durability. Stackable up to 4-high. **HON 5-Year Limited Warranty.**

HON Recommendation: HVL508.ES10 - List Price \$217

HVL518



GUEST CHAIR

Leg Base
Arms
Stacks up to Four High

DIMENSIONS

Depth:	22¼	Arm Width:	20¼
Width:	24	Seat to Floor Height:	17¾
Height:	35¾	Usable Seat Depth:	17½
Seat Depth:	17½	Ship Weight:	22.2 Ⓢ
Seat Width:	18½	Cube:	3.2
Back Width:	17½	Weight Rating:	250 lbs.
Back Height:	19		

PRICE CODE

Fabric **\$242**

NOTES: Mesh back. Fixed arms. Double cross bar frame increases strength and durability. Stackable up to 4-high. Black fabric seat. **HON 5-Year Limited Warranty.**

HON Recommendation: HVL518.ES10 - List Price \$242

HVL528



CAFÉ STOOL

Leg Base
Armless

DIMENSIONS

Depth:	23¾	Back Height:	19
Width:	20½	Seat to Floor Height:	33⅞
Height:	49¾	Usable Seat Depth:	17½
Seat Depth:	17½	Ship Weight (armless):	40.0 Ⓢ
Seat Width:	18½	Cube (armless):	7.0
Back Width:	17½	Weight Rating:	250 lbs.

PRICE CODE

Fabric
Per Carton **\$614**
Single Unit **\$307.00**

NOTES: Mesh back. Black fabric seat. Ships two per carton. **HON 5-Year Limited Warranty.**

Ⓢ Instigate™ HVL538 and HVL528 are ordered and shipped two (2) stools per carton. Pricing shown is per carton. Each set of two (one carton), must have the same fabric/frame color. Ordering 2 of any model will result in 2 cartons being shipped, giving you 4 stools.

HON Recommendation: HVL528.ES10 - List Price \$614

HVL538



CAFÉ STOOL

Leg Base
Arms

DIMENSIONS

Depth:	23¾	Arm Width:	20¼
Width:	20½	Seat to Floor Height:	33⅞
Height:	49¾	Usable Seat Depth:	17½
Seat Depth:	17½	Ship Weight:	44.5 Ⓢ
Seat Width:	18½	Cube:	7.8
Back Width:	17½	Weight Rating:	250 lbs.
Back Height:	19		

PRICE CODE

Fabric
Per Carton **\$667**
Single Unit **\$333.50**

NOTES: Mesh back. Black fabric seat. Fixed arms. Ships two per carton. **HON 5-Year Limited Warranty.**

HON Recommendation: HVL538.ES10 - List Price \$667

HOW TO SPECIFY

Select Model Number	Select Fabric
	ES10 Black Fabric (only)
H V L 5 1 8 .	E S 1 0

INVITATION® 2110 SERIES



Invitation Guest Chairs
and Table Connectors.

INVITATION® 2110 SERIES

Invitation brings the comforts of home into the workplace. Enjoy the simple pleasure of welcoming guests in arm chairs with integrated tables. Invitation guest chairs coordinate with Invitation lounge seating to make any space more comfortable and cohesive. Arrange in rows, groups or any configuration to suit your space or needs. The practical design and long-lasting comfort adds up to a stylish Invitation.



FEATURES

- Contoured back rest on guest chairs delivers ergonomic comfort.
- Floating back design enables easy cleaning.
- Guest chairs can be ganged together to create straight rows.
- Molded polymer seat shell increases comfort and durability.
- Solid hardwood in one of eight attractive finishes.
- Warranted for users up to 250 lbs.

INVITATION® 2110 Series Options

MODEL OPTIONS

H2111



Guest Chair

Leg Base, Arms

H2112

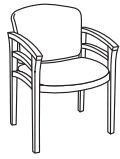

Guest Chair

Leg Base, Double
Rail Arms

HON BRANDED FABRICS

GRADE 1

Attire
Centurion
Compass
Contourett Polyurethane
Dapper
Hamilton
Inertia
Optic

GRADE 2

Appoint Seating
Clyde
Dotty
Rush
Seed
Spin Seating
Whisper Vinyl

GRADE 3

In Season
Purl
Silvertex™ Vinyl

AVAILABLE FINISHES

Invitation® 2110 Series Seating is available in 8 wood finishes.

WOOD FINISHES

Bourbon Cherry (H)

Cognac (COGN)

Harvest (C)

Mahogany (N)

Mocha (MOCH)

Natural Maple (D)

Pinnacle (PINC)

Shaker Cherry (F)

For a complete list of fabrics, including partnership fabrics, go to hon.com/fabricsandfinishes.

Reference Fabric Color Combinations on pages 18-22 for color codes and legend on page 19 for lead times. COM yardage shown is for Pattern Cut only. Contact Customer Service for Railroaded yardage requirements. For additional HON to Supply COM fabric grade pricing, go to honready.hon.com and click on the HON to Supply COM link.

⚡ For Fire Code model, availability and ordering method, refer to pages 26-29. Available on select models, contact HON Customer Support for availability.

INVITATION® 2110 Series

GSA SIN 33721



Icon Legend on page 15

H2111



GUEST CHAIR

Leg Base
Arms

DIMENSIONS

Depth:	22	Arm Width:	18 ⁷ / ₈
Width:	23 ¹ / ₂	Seat to Floor Height:	18 ¹ / ₂
Height:	33 ³ / ₈	Usable Seat Depth:	17
Seat Depth:	17	Ship Weight:	24
Seat Width:	20	Cube:	15.0
Back Width:	21	COM:	1.5
Back Height:	16	Weight Rating:	250 lbs.

FABRIC PRICE CODES

1	\$806	8	\$1013
2	\$842	9	\$1040
3	\$878	10	\$1067
4	\$905	11	\$1094
5	\$932	12	\$1121
6	\$959	L	—
7	\$986		

H2112



GUEST CHAIR

Leg Base
Double Rail Arms

DIMENSIONS

Depth:	22	Arm Width:	18 ⁷ / ₈
Width:	23 ¹ / ₂	Seat to Floor Height:	18 ¹ / ₂
Height:	33 ³ / ₈	Usable Seat Depth:	17
Seat Depth:	17	Ship Weight:	28
Seat Width:	20	Cube:	15.0
Back Width:	21	COM:	1.5
Back Height:	16	Weight Rating:	250 lbs.

FABRIC PRICE CODES

1	\$885	8	\$1092
2	\$921	9	\$1119
3	\$957	10	\$1146
4	\$984	11	\$1173
5	\$1011	12	\$1200
6	\$1038	L	—
7	\$1065		

HON Recommendation: H2111.MOCH.CU__ - List Price \$806

HOW TO SPECIFY

Select
Model Number

H 2 1 1 1 .

Select
Finish

See page 159

M O C H .

Select
Fabric

See page 159

C U 1 0 .



Icon Legend on page 15

INVITATION® 2110 Series Connectors

H2141



CONNECTORS

for Model H2111
One connector per two chairs

DIMENSIONS

Depth: 13⁵/₁₆ Ship Weight: 2.0 **Ⓢ**
Width: 4³/₈ Cube: 0.3
Height: 1 Weight Rating: 300 lbs.

LIST PRICE

\$59

H2142



CORNER TABLE CONNECTOR

for Model H2111

DIMENSIONS

Depth: 28 Ship Weight: 25.5 **Ⓢ**
Width: 28 Cube: 2.6
Height: 17¹/₄ Weight Rating: 300 lbs.

LIST PRICE

\$522



! Customer or dealer must attach leg to table.

H2143

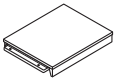

STRAIGHT TABLE CONNECTOR

for Model H2111

DIMENSIONS

Depth: 17¹/₈ Ship Weight: 16.5 **Ⓢ**
Width: 21 Cube: 1.5
Height: 17¹/₄ Weight Rating: 300 lbs.

LIST PRICE

\$377

H2144



CONNECTORS

for Model H2112
One connector per two chairs

DIMENSIONS

Depth: 13⁵/₁₆ Ship Weight: 2.0 **Ⓢ**
Width: 4³/₈ Cube: 0.3
Height: 1⁵/₁₆ Weight Rating: 300 lbs.

LIST PRICE

\$59

H2145

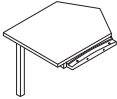

CORNER TABLE CONNECTOR

for Model H2112

DIMENSIONS

Depth: 28 Ship Weight: 25.5 **Ⓢ**
Width: 28 Cube: 2.6
Height: 17¹/₄ Weight Rating: 300 lbs.

LIST PRICE

\$522



! Customer or dealer must attach leg to table.

H2146

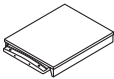

STRAIGHT TABLE CONNECTOR

for Model H2112

DIMENSIONS

Depth: 17¹/₈ Ship Weight: 16.5 **Ⓢ**
Width: 21 Cube: 1.5
Height: 17¹/₄ Weight Rating: 300 lbs.

LIST PRICE

\$377

HOW TO SPECIFY

Select Model Number	Select Finish
	See page 159
H 2 1 4 1 .	H

INVITATION® LOUNGE



Invitation Lounge.

INVITATION® LOUNGE

Welcome your guests in professional style. Enjoy the simple pleasure of relaxing on a sofa with a laptop or welcoming guests in plush arm chairs. The Invitation lounge collection combines gracefully sloping arms, tapered wood legs and the deep-foam comfort of separate seat cushions.



FEATURES

- Transitional design blends contemporary lines and traditional details.
- Clean lines and refined scale easily adapt to any private office or lobby.
- Contemporary tapered legs are offered in Platinum metallic or Black finish.
- Impressive design and fine craftsmanship in an affordably priced lounge chair.
- Removable seat cushion is deeply padded for added comfort.
- Warranted for users up to 250 lbs.

INVITATION® Lounge Options

MODEL OPTIONS

HFAA01



Arm Chair

HFALO2

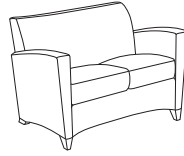

Love Seat

HFAS03

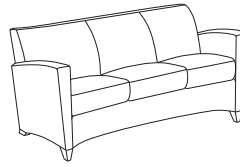

Sofa

LEG COLOR



CODE	DESCRIPTION	PRICE
T	Black	+\$0



T1	Platinum Metallic	+\$0
----	-------------------	-------------

CARTON

CODE	DESCRIPTION	PRICE
BC	Carton	+\$0

HON BRANDED FABRICS

GRADE 1

Attire
Centurion
Compass
Contourett Polyurethane
Dapper
Hamilton
Inertia
Optic

GRADE 2

Appoint Seating
Clyde
Dotty
Rush
Seed
Spin Seating
Whisper Vinyl

GRADE 3

In Season
Purl
Silvertex™ Vinyl

GRADE L

Denver Leather

For a complete list of fabrics, including partnership fabrics, go to hon.com/fabricsandfinishes.

Reference Fabric Color Combinations on pages 18-22 for color codes and legend on page 19 for lead times. For additional HON to Supply COM fabric grade pricing, go to honready.hon.com and click on the HON to Supply COM link.

🔥 For Fire Code model, availability and ordering method, refer to pages 26-29. Available on select models, contact HON Customer Support for availability.

INVITATION® Lounge

GSA SIN 33721



Icon Legend on page 15

HFAA01

ARM CHAIR



DIMENSIONS

Depth:	31½	Arm Width:	20
Width:	30	Seat to Floor Height:	18
Height:	34	Usable Seat Depth:	20
Seat Depth:	20	Ship Weight:	73
Seat Width:	20	Cube:	27.0
Back Width:	20	COM:	5.0
Back Height:	16	Weight Rating:	250 lbs.

FABRIC PRICE CODES

1	\$1895	8	\$2585
2	\$2015	9	\$2675
3	\$2135	10	\$2765
4	\$2225	11	\$2855
5	\$2315	12	\$2945
6	\$2405	L	\$2895
7	\$2495		

HFAL02

LOVE SEAT

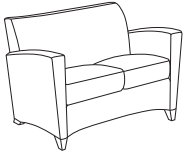

DIMENSIONS

Depth:	31¾	Arm Width:	40¼
Width:	50¼	Seat to Floor Height:	18
Height:	34¼	Usable Seat Depth:	20
Seat Depth:	20	Ship Weight:	112
Seat Width:	40¼	Cube:	55.7
Back Width:	40¼	COM:	6.5
Back Height:	16	Weight Rating:	250 lbs.

FABRIC PRICE CODES

1	\$2604	8	\$3501
2	\$2760	9	\$3618
3	\$2916	10	\$3735
4	\$3033	11	\$3852
5	\$3150	12	\$3969
6	\$3267	L	\$3904
7	\$3384		

HFAS03

SOFA

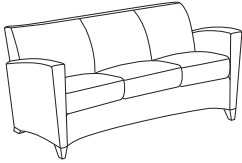

DIMENSIONS

Depth:	32	Arm Width:	60½
Width:	70½	Seat to Floor Height:	18
Height:	34½	Usable Seat Depth:	20
Seat Depth:	20	Ship Weight:	140
Seat Width:	60½	Cube:	72.0
Back Width:	60½	COM:	8.5
Back Height:	16	Weight Rating:	250 lbs.

FABRIC PRICE CODES

1	\$3313	8	\$4486
2	\$3517	9	\$4639
3	\$3721	10	\$4792
4	\$3874	11	\$4945
5	\$4027	12	\$5098
6	\$4180	L	\$5013
7	\$4333		

HON Recommendation: HFAA01.PNS__T.BC - List Price \$2015

HOW TO SPECIFY

<p>Select Model Number</p> <p>HFAA01</p>	<p>Select Fabric</p> <p>See page 163</p> <p>PNS007</p>	<p>Select Leg Color</p> <p>T Black T1 Platinum Metallic</p> <p>T</p>	<p>Select Carton Option</p> <p>BC Carton</p> <p>BC</p>
--	--	--	--



Lota Mesh Back Work and Side Chair with Voi® desks.

LOTA®

If you're looking for all-day comfort without breaking the bank, look no further than Lota. This mesh back family of task and guest chairs offer advanced features for customizable comfort that make it an upscale choice at an affordable price. Lota's control mechanism uses your own weight to provide perfect balance while reclining, and the pivoting arms put upper body support right where it's needed. If you sit for hours on end, put yourself in more control over your comfort.



FEATURES

- Weight-activated control responds naturally to your body's movements without any adjustments.
- 3-way arms adjust to various heights, depths and pivot positions.
- Multi-purpose chairs feature black arms and base.
- One-touch seat height adjustment easily moves the seat up and down.
- Tilt tension controls the rate and ease of recline.
- Tilt lock allows the user to lock out the tilt function.
- 360-degree swivel provides freedom of movement in any direction.
- Polished Aluminum arms and base available on Models H2283 and H2284.
- Models H2281 and H2283 available in black, charcoal and navy fabrics.
- Models H2282 and H2284 available in hundreds of HON fabric options.
- H2285 available in black fabric only.
- Multi-purpose chairs stack four high on the floor.
- Warranted for users up to 275 lbs.

LOTA[®] Options

MODEL OPTIONS

H2281



Mid-Back Work (Mesh Back)

Pneumatic, Tilt Lock, Weight-Activated Control, Height, Depth, Pivot Adjustable Arms, Black Arms and Base

H2283



Mid-Back Work (Mesh Back)

Pneumatic, Tilt Lock, Weight-Activated Control, Height, Depth, Pivot Adjustable Arms, Polished Aluminum Arms, Base, and Back Upright

H2285



Multi-Purpose (Mesh Back)

4-Leg Stacking Frame, Fixed Arms

H2282



Mid-Back Work (Mesh Back)

Pneumatic, Tilt Lock, Weight-Activated Control, Height, Depth, Pivot Adjustable Arms, Black Arms and Base

H2284



Mid-Back Work (Mesh Back)

Pneumatic, Tilt Lock, Weight-Activated Control, Height, Depth, Pivot Adjustable Arms, Polished Aluminum Arms, Base, and Back Upright

CASTERS



CODE	DESCRIPTION	PRICE
H	Hard Caster	+\$0



S	Soft Caster	+\$30
----------	-------------	--------------

**Casters available on H2282 and H2284 only*

FRAME

CODE	DESCRIPTION	PRICE
T	Black	+\$0

**Available on H2281 and H2282 only*

PA	Polished Aluminum	+\$0
-----------	-------------------	-------------

**Available on H2283 and H2284 only*

LOTA[®] MID-BACK WORK H2281/H2283

GRADE 1	GRADE 2	GRADE 3
Black Fabric Charcoal Fabric Navy Fabric		

LOTA[®] MID-BACK WORK H2282/H2284 HON BRANDED FABRICS

GRADE 1	GRADE 2	GRADE 3
Attire Centurion Compass Contourett Polyurethane Dapper Hamilton Inertia Optic	Appoint Seating Clyde Dotty Rush Seed Spin Seating Whisper Vinyl	In Season Purl Silvertex™ Vinyl

For a complete list of fabrics, including partnership fabrics, go to hon.com/fabricsandfinishes.

Reference Fabric Color Combinations on pages 18-22 for color codes and legend on page 19 for lead times.

MULTI-PURPOSE H2285 HON BRANDED FABRICS

GRADE 1	GRADE 2	GRADE 3
Black Fabric		



H2281



MID-BACK WORK CHAIR

Mesh Back
 Pneumatic
 Tilt Lock
 Weight-activated Control
 Height, Depth, Pivot Adjustable
 Arms
 Black Arms and Base

Functions: **A, E, F, L, Q**
 (Function Key on pages 16-17)

! Black Mesh back only.

DIMENSIONS

Depth:	27¾	Arm Width:	20⅞
Width:	26¾	Seat to Floor Height:	17⅞-21⅞
Height:	43½	Usable Seat Depth:	17¼
Seat Depth:	17¼	Ship Weight:	50 Ⓢ
Seat Width:	19½	Cube:	6.5
Back Width:	17¾	Weight Rating:	250 lbs.
Back Height:	23½		

LIST PRICE

\$753

H2283



MID-BACK WORK CHAIR

Mesh Back
 Pneumatic
 Tilt Lock
 Weight-activated Control
 Height, Depth, Pivot Adjustable
 Arms
 Polished Aluminum Arms, Base,
 and Back Upright

Functions: **A, E, F, L, Q**
 (Function Key on pages 16-17)

! Black Mesh back only.

DIMENSIONS

Depth:	27¾	Arm Width:	20¼
Width:	26¾	Seat to Floor Height:	17-21
Height:	43⅝	Usable Seat Depth:	17¼
Seat Depth:	17¼	Ship Weight:	53 Ⓢ
Seat Width:	19½	Cube:	6.5
Back Width:	17¾	Weight Rating:	250 lbs.
Back Height:	23½		

LIST PRICE

\$925

HON Recommendation: H2281.VA10.T - List Price \$753

HOW TO SPECIFY

<p>Select Model Number</p> <p>H 2 2 8 1 .</p> <p>H 2 2 8 3 .</p>	<p>Select Fabric</p> <p>VA10 Black Fabric VA19 Charcoal Fabric VA90 Navy Fabric</p> <p>V A 1 0 .</p> <p>V A 1 0 .</p>	<p>Select Frame</p> <p>T Black (available on model H2281 only) PA Polished Aluminum (available on model H2283 only)</p> <p>T</p> <p>P A</p>
---	---	---



H2282



MID-BACK WORK CHAIR

Mesh Back
 Pneumatic
 Tilt Lock
 Weight-activated Control
 Height, Depth, Pivot Adjustable
 Arms
 Black Arms and Base

DIMENSIONS

Depth: 27¾
 Width: 26¾
 Height: 43½
 Seat Depth: 17¼
 Seat Width: 19½
 Back Width: 17¾
 Back Height: 23½
 Arm Width: 20⅞
 Seat to Floor Height: 17⅞-21⅞
 Usable Seat Depth: 17¼
 Ship Weight: 50 Ⓢ
 Cube: 6.5
 Weight Rating: 250 lbs.

FABRIC PRICE CODES

1	\$828	8	\$966
2	\$852	9	\$984
3	\$876	10	\$1002
4	\$894	11	\$1020
5	\$912	12	\$1038
6	\$930	L	—
7	\$948		

Functions: **A, E, F, L, Q**
 (Function Key on pages 16-17)

! Black Mesh back only.

H2284



MID-BACK WORK CHAIR

Mesh Back
 Pneumatic
 Tilt Lock
 Weight-activated Control
 Height, Depth, Pivot Adjustable
 Arms
 Polished Aluminum Arms, Base,
 and Back Upright

DIMENSIONS

Depth: 27¾
 Width: 26¾
 Height: 43⅝
 Seat Depth: 17¼
 Seat Width: 19½
 Back Width: 17¾
 Back Height: 23½
 Arm Width: 20¼
 Seat to Floor Height: 17-21
 Usable Seat Depth: 17¼
 Ship Weight: 53 Ⓢ
 Cube: 6.5
 Weight Rating: 250 lbs.

FABRIC PRICE CODES

1	\$997	8	\$1135
2	\$1021	9	\$1153
3	\$1045	10	\$1171
4	\$1063	11	\$1189
5	\$1081	12	\$1207
6	\$1099	L	—
7	\$1117		

Functions: **A, E, F, L, Q**
 (Function Key on pages 16-17)

! Black Mesh back only.

HON Recommendation: H2282.H.CU__T - List Price \$828

HOW TO SPECIFY

<p>Select Model Number</p> <p>H 2 2 8 2 . H 2 2 8 4 .</p>	<p>Select Caster</p> <p>H Hard Caster S Soft Caster (+ \$30)</p> <p>H . H .</p>	<p>Select Fabric</p> <p>See page 167</p> <p>C U 1 0 . C U 1 0 .</p>	<p>Select Frame</p> <p>T Black (available on model H2282 only) PA Polished Aluminum (available on model H2284 only)</p> <p>T P A</p>
---	--	---	---



H2285



MULTI-PURPOSE CHAIR

Mesh Back
4-Leg Stacking Frame
Fixed Arms

DIMENSIONS

Depth:	24 ³ / ₄	Arm Width:	19 ¹ / ₈
Width:	23	Seat to Floor Height:	19 ¹ / ₈
Height:	34 ¹ / ₂	Usable Seat Depth:	17 ³ / ₄
Seat Depth:	17 ³ / ₄	Ship Weight:	20
Seat Width:	18 ⁷ / ₈	Cube:	2.8
Back Width:	17 ¹ / ₈	Weight Rating:	250 lbs.
Back Height:	17 ³ / ₄		

LIST PRICE

\$392

NOTES: Casters and glides ship packaged together for customer's assembly choice. Stacks 4-high on floor.

Available in VA10 Black fabric seat and Black frame only. Black Mesh back only.

HOW TO SPECIFY

Select
Model Number

H 2 2 8 5 .

Select
Fabric
VA10 Black Fabric

V A 1 0 .

Select
Frame
T Black

T

MATTER™



Matter™ Upholstered Chair with 5-Star Base with Preside® Table.

MATTER™

This modern take on the traditional task chair combines the comfort of a lounge chair and posture of a task chair. The synchro-tilt control allows you to find that reclining position that's just right for you, and the five-star base lets you move around effortlessly. The chrome accents with Gray fabric not only create a truly modern aesthetic, they compliment any workspace.



FEATURES

- Brings a modern design aesthetic into any reception or guest area.
- Synchro-tilt mechanism offers a full range of reclining positions.
- Chrome arms and base provides a contemporary accent.
- 360-degree swivel.
- Available in a 5-star base and 4-leg natural wood base.
- Easily assembled in minutes.
- Backed by HON 5-year limited warranty.

MATTER™

Multi-Purpose Chairs

OPEN MARKET



Icon Legend on page 15

HVL232



GRAY UPHOLSTERED CHAIR

with 5-Star Base
Swivel
Tilt

DIMENSIONS

Depth:	24 ⁴ / ₅	Arm Width:	3
Width:	23	Seat to Floor Height:	19
Height:	34	Usable Seat Depth:	18
Seat Depth:	18 ³ / ₁₀	Ship Weight:	21 S
Seat Width:	16 ¹ / ₂	Cube:	5.6
Back Width:	23	Weight Rating:	250 lbs.
Back Height:	12 ² / ₅		

LIST PRICE

\$380

NOTES: HON 5-Year Limited Warranty.

HVL238



GRAY UPHOLSTERED CHAIR

Wood Leg Base
Harvest Wood Legs
4-Leg Wood Base

DIMENSIONS

Depth:	24 ⁴ / ₅	Arm Width:	3
Width:	23	Seat to Floor Height:	19
Height:	34	Usable Seat Depth:	18
Seat Depth:	18 ³ / ₁₀	Ship Weight:	21 S
Seat Width:	16 ¹ / ₂	Cube:	5.6
Back Width:	23	Weight Rating:	250 lbs.
Back Height:	12 ² / ₅		

LIST PRICE

\$350

NOTES: HON 5-Year Limited Warranty.

HOW TO SPECIFY

<p>Select Model Number</p> <p>H V L 2 3 8 .</p>	<p>Select Fabric</p> <p>GRY01 Light Gray</p> <p>GRY01</p>
---	---



Merit™ Executive Conference Chair with Voi® Desks.

MERIT™

Merit™ is the answer for anyone who wants the experience of sitting in a refined executive chair combined with the sleek look of a European conference chair. A channel stitched back and polished aluminum arm and base accents provide the initial attraction, but the supreme comfort of the weight-activated control makes them stay. This modern, streamlined look is complemented by a luxurious sitting experience.



FEATURES

- Weight-activated tilt-control mechanism provides natural, ergonomic reclining position.
- Leather wrapped back includes channel stitching for upscale look. Available in Black or Gray.
- Color-matched soft arm cap.
- Pneumatic seat height adjustment.
- Molded foam seat and back.
- Padded headrest.
- Weight rating of 275 lbs.

MERIT™ Executive Conference Chair

OPEN MARKET



Icon Legend on page 15

HME3



EXECUTIVE CONFERENCE CHAIR

Pneumatic
Swivel
Weight-activated Control
Tilt Lock
Fixed Arms
Functions: **A, E, F, L, T**
(Function Key on pages 16-17)

DIMENSIONS

Depth:	24 ² / ₅	Arm Width:	1 ¹ / ₅
Width:	24 ² / ₅	Seat to Floor Height:	18 ³ / ₁₀
Height:	46 ⁴ / ₅	Usable Seat Depth:	18 ¹ / ₂
Seat Depth:	20	Ship Weight:	47.5
Seat Width:	20	Cube:	14.3
Back Width:	19 ³ / ₁₀	Weight Rating:	275 lbs.
Back Height:	35		

LIST PRICE

Leather \$950

NOTES: Black or Gray leather options. Detailed channel stitching on back. Polished arms and base. Fixed arms with color-matched soft arm cap.

HON Recommendation: HME3.W5.P.H.LR58.PA - List Price \$950

HOW TO SPECIFY

Select Model Number HME3	Select Control Type W5 Weight-Activated	Select Arm Type P Fixed Arms - Polished	Select Caster H Hard Caster	Select Fabric LR58 Black Leather LR29 Gray Leather	Select Base PA Polished Aluminum
---	--	--	--	---	---

MOTIVATE® CHAIRS



Motivate® 4-Leg Stacking Chairs and Between™ Table.

MOTIVATE® CHAIRS

A presentation in the morning. A training session in the afternoon. Today's multi-purpose spaces are in constant flux, and need an adaptable seating solution that delivers instant comfort for all, while easily moving around to support various activities. Motivate task chairs, stacking/nesting chairs and guest chairs create a streamlined collection of seating that intuitively responds to your body's natural movements and curves. Whether sitting for five minutes or five hours, when you Motivate your team you put everyone at ease.



FEATURES

- Choose plastic, upholstered or 4-Way Stretch mesh back.
- Easily move chairs around the space for quick rearrangement.
- HMN1 nesting/stacking chairs stack four high on the floor.
- HMS1 sled base chairs stack 12 high on the floor or 40 high on a cart.
- HMS2 sled base chairs stack six high on the floor.
- Dynamic flex-zone motion in seat and back provides balance and lumbar support.
- Model HMT5 task stool features an adjustable footring.
- Plastic shell is available in 13 colors.
- Available in hundreds of quality HON fabrics.
- Warranted for users up to 300 lbs.

TASK CHAIR FEATURES

- One-touch seat height adjustment easily moves the seat up and down.
- 360-degree swivel provides freedom of movement in any direction.
- Warranted for users up to 300 lbs.

MOTIVATE® Task Chair Options

MODEL OPTIONS

HMT1



Flex-back

Upholstered Seat,
Pneumatic, Swivel

HMT5



Flex-back

Upholstered Seat,
Pneumatic, Swivel
Adjustable Footring

ARM STYLE

CODE	DESCRIPTION	PRICE
N	Armless	+\$0
A	Adjustable Arms	+\$70



CASTERS

CODE	DESCRIPTION	PRICE
H	Hard Caster	+\$0
S	Soft Caster	+\$30



BACK STYLE

CODE	DESCRIPTION	PRICE
<i>Plastic/Upholstered Options:</i>		
PS	Plastic Shell	+\$0
PB	Upholstered	+\$70



4-Way Stretch Options:

IM	Black	+\$80
IF	Fog	+\$80
IC	Charcoal	+\$80
IH	Chai	+\$80
IY	Navy	+\$80



PLASTIC SHELL COLOR CODES (no upcharge):

Tangelo - **RG**
Regatta - **RE**
Lava - **LA**

Cherry - **CR**
Mulberry - **MB**
Onyx - **ON**

Lime - **LM**
Loft - **LO**
White - **WT**

Calypso - **CP**
Platinum - **PT**

Surf - **BU**
Shadow - **SD**

BASE

CODE	DESCRIPTION	PRICE
SB	Standard Base	+\$0



FRAME COLOR

CODE	DESCRIPTION	PRICE
T	Black	+\$0

MOTIVATE[®]

Task Chair Fabric Options

HON BRANDED FABRICS

GRADE 1

Attire
Centurion
Compass
Contourett Polyurethane
Dapper
Hamilton
Inertia
Optic

GRADE 2

Appoint Seating
Clyde
Dotty
Rush
Seed
Spin Seating
Whisper Vinyl

GRADE 3

In Season
Purl
Silvertex™ Vinyl

GRADE L

Denver Leather

For a complete list of fabrics, including partnership fabrics, go to hon.com/fabricsandfinishes.

Reference Fabric Color Combinations on pages 18-22 for color codes and legend on page 19 for lead times.

! CA Technical Bulletin 133 Compliant available only in Onyx as a Standard Special. Please reach out to our Tailored Solutions Team.

MOTIVATE® Task Chairs

GSA SIN 33721



Icon Legend on page 15

HMT1

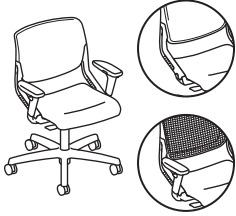

TASK CHAIR

Flex-back
Upholstered Seat
Pneumatic
Swivel

DIMENSIONS

Depth:	27½	Seat to Floor Height:	17-22½
Width:	27½	Usable Seat Depth:	18
Height:	37½	Ship Weight (upholstered back):	39 Ⓢ
Seat Depth:	18	Ship Weight (plastic/mesh back):	38 Ⓢ
Seat Width:	17½	Cube (upholstered back):	10.0
Back Width:	19½	Cube (plastic/mesh back):	10.0
Back Height:	17¾	COM (upholstered back):	1.5
Arm Width:	18½-20	COM (plastic/mesh back):	1.0
		Weight Rating:	300 lbs.

FABRIC PRICE CODES

1	\$438	8	\$645
2	\$474	9	\$672
3	\$510	10	\$699
4	\$537	11	\$726
5	\$564	12	\$753
6	\$591	L	—
7	\$618		

ⓘ When a Plastic Shell (PS) or Upholstered Back (PB) option is chosen, you must select a shell color. If the mesh back option is chosen, the shell color is not specified.

HMT5

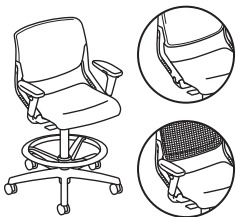

TASK STOOL

Flex-back
Upholstered Seat
Pneumatic
Swivel Adjustable Footring

DIMENSIONS

Depth:	28¼	Seat to Floor Height:	22½-32½
Width:	28¼	Usable Seat Depth:	18
Height:	50½	Ship Weight (upholstered back):	44 Ⓢ
Seat Depth:	18	Ship Weight (plastic/mesh back):	43 Ⓢ
Seat Width:	17½	Cube (upholstered back):	10.0
Back Width:	19½	Cube (plastic/mesh back):	10.0
Back Height:	17¾	COM (upholstered back):	1.5
Arm Width:	18½-20	COM (plastic/mesh back):	1.0
		Weight Rating:	300 lbs.

FABRIC PRICE CODES

1	\$497	8	\$704
2	\$533	9	\$731
3	\$569	10	\$758
4	\$596	11	\$785
5	\$623	12	\$812
6	\$650	L	—
7	\$677		

NOTES: Stool model has adjustable footring.

ⓘ When a Plastic Shell (PS) or Upholstered Back (PB) option is chosen, you must select a shell color. If the mesh back option is chosen, the shell color is not specified.

HON Recommendation: HMT1.A.H.IM.CU__SB.T - List Price \$588

HOW TO SPECIFY

Select Model Number	Select Arm Type	Select Caster	Select Back Type/Color	Select Fabric	Select Base	Select Frame
	A Adjustable Arms (+ \$70) N Armless	H Hard Caster S Soft Caster (+ \$30)	PS Plastic Shell PB Upholstered (+ \$70) If PS or PB options are chosen, select shell color. Plastic Shell Colors RG Tangelo LO Loft CR Cherry PT Platinum LM Lime SD Shadow CP Calypso LA Lava BU Surf ON Onyx RE Regatta WT White MB Mulberry 4-Way Stretch options (+ \$80) IM Black IH Chai IF Fog IY Navy IC Charcoal	See page 177	SB Standard Base	T Black
HMT1	A	H	IM	CU10	SB	T
HMT1	A	H	PSLA	CU10	SB	T

MOTIVATE® High-Density Sled Base Chair Options

MODEL OPTIONS

HMS1



High-Density Stacker



Sled Leg Base

HMS2



High-Density Stacker

Upholstered Seat, Sled Leg Base

ARM STYLE	CODE	DESCRIPTION	PRICE	FRAME	CODE	DESCRIPTION	PRICE
	F	Fixed Arms	+\$30		Y	Chrome	+\$0
	N	Armless	+\$0		P1 PAINT:		+\$0
					BLCK	Textured Black	
					P7J	Textured Brownstone	
					P7A	Textured Charcoal	
					PK7	Textured Designer White	
					P7L	Textured Loft	
					P7M	Textured Muslin	
					P8V	Textured Titanium	
					P2 PAINT:		+\$0
					PLAT	Textured Platinum Metallic	
					PR8	Textured Silver	
					P3 PAINT:		+\$30
					P8S	Atom	
					PJF	Bullseye	
					P8P	Ember	
					P8N	Ion	
					P8J	Iris	
					P8F	Krypton	
					P8M	Regatta	

PLASTIC SHELL COLOR CODES (no upcharge): Tangelo - **RG** Cherry - **CR** Lime - **LM** Calypso - **CP** Surf - **BU**
 Regatta - **RE** Mulberry - **MB** Loft - **LO** Platinum - **PT** Shadow - **SD**
 Lava - **LA** Onyx - **ON** White - **WT**

❶ For CA Technical Bulletin 133, Onyx (ON) shell color is available as a Standard Special through HON's Tailored Solutions program. Please see pages 26-29 or contact HON Customer Support for more information.

HON BRANDED FABRICS

GRADE 1

Attire
Centurion
Compass
Contourett Polyurethane
Dapper
Hamilton
Inertia
Optic

GRADE 2

Appoint Seating
Clyde
Dotty
Rush
Seed
Spin Seating
Whisper Vinyl

GRADE 3

In Season
Purl
Silvertex™ Vinyl

For a complete list of fabrics, including partnership fabrics, go to hon.com/fabricsandfinishes.

Reference Fabric Color Combinations on pages 18-22 for color codes and legend on page 19 for lead times.

❶ For CA Technical Bulletin 133, Onyx (ON) shell color is available as a Standard Special through HON's Tailored Solutions program. Please see pages 26-29 or contact HON Customer Support for more information.

MOTIVATE® High-Density Sled Base Chairs

GSA SIN 33721



Icon Legend on page 15

HMS1

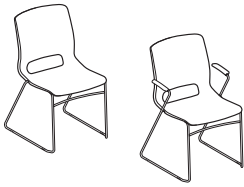

HIGH-DENSITY STACKER

Sled Leg Base

DIMENSIONS

Depth:	23	Arm Width:	18 $\frac{1}{8}$
Width:	21	Seat to Floor Height:	17 $\frac{3}{4}$
Height:	32 $\frac{1}{4}$	Usable Seat Depth:	18 $\frac{1}{4}$
Seat Depth:	18 $\frac{1}{4}$	Ship Weight:	72
Seat Width:	17 $\frac{3}{4}$	Cube:	15.2
Back Width:	17 $\frac{1}{4}$	Weight Rating:	300 lbs.
Back Height:	18		

LIST PRICE PER CARTON

\$834

(reference single unit @
\$208.50)

NOTES: HMS1 Sled Base chairs stack 12-high on the floor, or 40-high on the chair cart model HMSCART. Field installed glides snap-on using existing locations on the sled base frames.

ⓘ Ganging Chair Glides are designed for use on armless models of the Motivate® High-Density Sled Base Chairs only. Not for use on models specified with arms.

📦 Ships four (4) chairs per carton.

HMS2

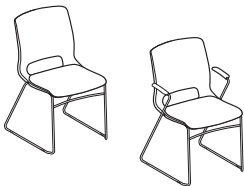

HIGH-DENSITY STACKER

Upholstered Seat
Sled Leg Base
Set of 4

DIMENSIONS

Depth:	23	Arm Width:	18 $\frac{1}{8}$
Width:	21	Seat to Floor Height:	18 $\frac{1}{4}$
Height:	32 $\frac{1}{4}$	Usable Seat Depth:	18 $\frac{1}{4}$
Seat Depth:	18 $\frac{1}{4}$	Ship Weight:	80
Seat Width:	17 $\frac{3}{4}$	Cube:	15.2
Back Width:	17 $\frac{1}{4}$	COM (per 4 pack):	1.6
Back Height:	17 $\frac{1}{2}$	Weight Rating:	300 lbs.

FABRIC PRICE CODES

1	\$1071	8	\$1209
2	\$1095	9	\$1227
3	\$1119	10	\$1245
4	\$1137	11	\$1263
5	\$1155	12	\$1281
6	\$1173	L	—
7	\$1191		

NOTES: HMS2 Sled Base chairs stack 6-high on the floor. Field installed glides snap-on using existing locations on the sled base frames.

ⓘ Ganging Chair Glides are designed for use on armless models of the Motivate® High-Density Sled Base Chairs only. Not for use on models specified with arms. Upholstered seat model HMS2 is not designed to be stacked on the HMSCART.

📦 Motivate® Sled Base Chairs are ordered and shipped four (4) chairs per carton. Pricing shown is per carton. Each set of four chairs (one carton), must have the same shell/frame color combination. Ordering 2 of Model HMS1, HMS2 will result in 2 cartons being shipped, giving you 8 chairs.

HMSCART



CART FOR HMS1 STACKING CHAIRS

DIMENSIONS

Depth:	34 $\frac{1}{4}$	Ship Weight:	40
Width:	21 $\frac{3}{8}$	Cube:	7.8
Height:	36 $\frac{3}{8}$		

LIST PRICE

\$479

NOTES: Holds up to 40 Stacking Chairs.

HON Recommendation: HMS1.N.ON.Y - List Price \$834

HOW TO SPECIFY

<p>Select Model Number</p> <p>HMS1 .</p> <p>HMS2 .</p>	<p>Select Arm Type</p> <p>F Fixed Arms (+ \$30 per chair)</p> <p>N Armless</p> <p>N .</p> <p>N .</p>	<p>Select Shell Color</p> <p>RG Tangelo LO Loft</p> <p>CR Cherry PT Platinum</p> <p>LM Lime SD Shadow</p> <p>CP Calypso LA Lava</p> <p>BU Surf ON Onyx</p> <p>RE Regatta WT White</p> <p>MB Mulberry</p> <p>ON .</p> <p>ON .</p>	<p>Select Fabric</p> <p>See page 179</p> <p>Not specified for HMS1 models</p> <p>CUT0 .</p>	<p>Select Frame</p> <p>See page 179</p> <p>BLCK</p> <p>BLCK</p>
---	---	---	--	--



MOTIVATE® High-Density Sled Base Chairs

HMSGLD

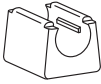

GLIDES FOR MOTIVATE® HIGH-DENSITY STACKER

- Kit includes 48 glides for 12 chairs
- Field installed
- Snap-on using existing locations on frames

DIMENSIONS

Ship Weight: 1 Ⓢ
Cube: 0.2

LIST PRICE

\$64

HMSFLTGLD



FELT GLIDES FOR MOTIVATE® HIGH-DENSITY STACKER

- Kit includes 48 glides for 12 chairs
- Field installed
- Snap-on using existing locations on frames

DIMENSIONS

Ship Weight: 1 Ⓢ
Cube: 0.2

LIST PRICE

\$165

HMSSTLGLD



STEEL GLIDES FOR MOTIVATE® HIGH-DENSITY STACKER

- Kit includes 48 glides for 12 chairs
- Field installed
- Snap-on using existing locations on frames

DIMENSIONS

Ship Weight: 1 Ⓢ
Cube: 0.2

LIST PRICE

\$165

HMSGANG

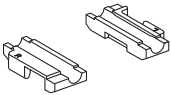

GANGING CONNECTORS FOR MOTIVATE® HIGH-DENSITY STACKER

- 48 ganging connectors
- Requires 4 connectors per ganging connection
- For use on HMS1.N and HMS2.N only (armless models)
- Field installed
- Snap-on using existing locations on frames

DIMENSIONS

Ship Weight: 1 Ⓢ
Cube: 0.2

LIST PRICE

\$121

Floor Covering	TYPE OF GLIDE		
	Polycarbonate/Nylon	Felt	Steel
Carpet	Best	Not Recommended	Good
Polished concrete	Best	Good	Not Recommended
Hard wood	Not Recommended	Best	Not Recommended
Vinyl (includes LVT)	Best	Better	Good
VCT	Best	Good	Not Recommended
Tile (Porcelain/Ceramic)	Best	Good	Not Recommended

HOW TO SPECIFY

Select Model Number

HMSGLD

MOTIVATE® 4-Leg Chair Options

MODEL OPTIONS

HMG1



Stack Chair

Four Legs, Set of 2

HMG2



Stack Chair

Four Legs, Upholstered
Seat, Set of 2

HMG5



Café-Height Stool

Four Legs

HMG7



Café-Height Stool

Four Legs, Upholstered
Seat

ARM STYLE



CODE	DESCRIPTION	PRICE
F	Fixed Arms	+\$30



N	Armless	+\$0
----------	---------	-------------

CASTERS/ GLIDES



CODE	DESCRIPTION	PRICE
H	Hard Caster	+\$0



S	Soft Caster	+\$20
----------	-------------	--------------

**Casters only available on HMG1 and HMG2*



E	Standard Nylon Glide	+\$0
F	Felt Glide	+\$30
R	Rubber Glide	+\$30
T	Steel Glide	+\$30

FRAME

CODE	DESCRIPTION	PRICE
P1 PAINT:		+\$0
BLCK	Textured Black	
P7J	Textured Brownstone	
P7A	Textured Charcoal	
PK7	Textured Designer White	
P7L	Textured Loft	
P7M	Textured Muslin	
P8V	Textured Titanium	
P2 PAINT:		+\$0
PLAT	Textured Platinum Metallic	
PR8	Textured Silver	
P3 PAINT:		+\$30
P8S	Atom	
PJF	Bullseye	
P8P	Ember	
P8N	Ion	
P8J	Iris	
P8F	Krypton	
P8M	Regatta	

PLASTIC SHELL COLOR CODES (no upcharge): Tangelo - **RG** Cherry - **CR** Lime - **LM** Calypso - **CP** Surf - **BU**
Regatta - **RE** Mulberry - **MB** Loft - **LO** Platinum - **PT** Shadow - **SD**
Lava - **LA** Onyx - **ON** White - **WT**

❗ For CA Technical Bulletin 133, Onyx (ON) shell color is available as a Standard Special through HON's Tailored Solutions program. Please see pages 26-29 or contact HON Customer Support for more information.

MOTIVATE[®]

4-Leg Chair Fabric Options

HON BRANDED FABRICS

GRADE 1

Attire
Centurion
Compass
Contourett Polyurethane
Dapper
Hamilton
Inertia
Optic

GRADE 2

Appoint Seating
Clyde
Dotty
Rush
Seed
Spin Seating
Whisper Vinyl

GRADE 3

In Season
Purl
Silvertex™ Vinyl

For a complete list of fabrics, including partnership fabrics, go to hon.com/fabricsandfinishes.

Reference Fabric Color Combinations on pages 18-22 for color codes and legend on page 19 for lead times.

❗ For CA Technical Bulletin 133, Onyx (ON) shell color is available as a Standard Special through HON's Tailored Solutions program. Please see pages 26-29 or contact HON Customer Support for more information.

MOTIVATE® 4-Leg Chairs

GSA SIN 33721



Icon Legend on page 15

HMG1

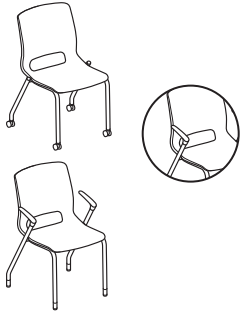

STACK CHAIR

Four Legs
Set of 2

DIMENSIONS

Depth:	23	Arm Width:	18
Width:	21	Seat to Floor Height:	17¾
Height:	32¼	Usable Seat Depth:	18¼
Seat Depth:	18¼	Ship Weight:	38
Seat Width:	17¾	Cube:	13.0
Back Width:	17¼	Weight Rating:	300 lbs.
Back Height:	18		

LIST PRICE PER CARTON

\$548
(reference single unit @
\$274.00)

NOTES: 4-Leg chairs stack 6-high on the floor.

Ships two (2) chairs per carton.

HMG2

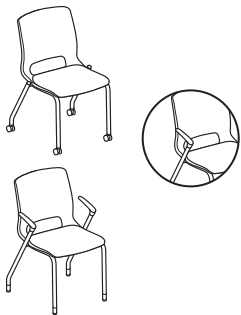

STACK CHAIR

Four Legs
Upholstered Seat
Set of 2

DIMENSIONS

Depth:	23	Arm Width:	18
Width:	21	Seat to Floor Height:	18¼
Height:	32¼	Usable Seat Depth:	18¼
Seat Depth:	18¼	Ship Weight:	44
Seat Width:	17¾	Cube:	13.0
Back Width:	17¼	COM (per 2 pack):	1.0
Back Height:	17½	Weight Rating:	300 lbs.

FABRIC PRICE CODES

1	\$674	8	\$812
2	\$698	9	\$830
3	\$722	10	\$848
4	\$740	11	\$866
5	\$758	12	\$884
6	\$776	L	—
7	\$794		

NOTES: 4-Leg chairs stack 6-high on the floor.

Motivate® 4-leg Chairs are ordered and shipped two (2) chairs per carton. Pricing shown is per carton. Each set of two chairs (one carton), must have the same shell/frame color combination. Ordering 2 of Model HMG1, HMG2 will result in 2 cartons being shipped, giving you 4 chairs. 4-Leg chairs stack 6-high on the floor.

HON Recommendation: HMG1.N.H.ON.PLAT - List Price \$548

HOW TO SPECIFY

Select Model Number	Select Arm Type	Select Caster/Glide	Select Shell Color	Select Fabric	Select Frame
F Fixed Arms (+ \$30 per chair) N Armless	H Hard Caster S Soft Caster (+ \$20 per chair) <i>Casters only available on HMG1 and HMG2</i> E Standard Nylon Glide F Felt Glide (+ \$30 per chair) R Rubber Glide (+ \$30 per chair) T Steel Glide (+ \$30 per chair)	RG Tangelo CR Cherry LM Lime CP Calypso BU Surf RE Regatta MB Mulberry	LO Loft PT Platinum SD Shadow LA Lava ON Onyx WT White	See page 183 <i>Not specified for models HMG1 and HMG5</i>	See page 182
HMG1	N	H	ON		PLAT
HMG2	N	H	ON	CU10	PLAT



MOTIVATE® 4-Leg Chairs

HMG3

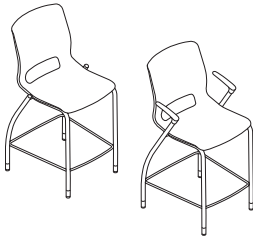

COUNTER-HEIGHT STOOL

Four Legs

DIMENSIONS

Depth:	23	Arm Width:	18
Width:	21	Seat to Floor Height:	24½
Height:	40½	Usable Seat Depth:	18½
Seat Depth:	18½	Ship Weight:	26
Seat Width:	17¾	Cube:	13.8
Back Width:	17¼	Weight Rating:	300 lbs.
Back Height:	18		

LIST PRICE

\$376

HMG4

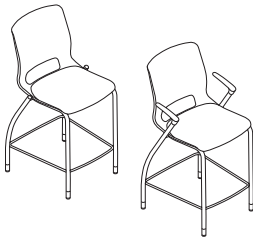

COUNTER-HEIGHT STOOL

Four Legs
Upholstered Seat

DIMENSIONS

Depth:	23	Arm Width:	18
Width:	21	Seat to Floor Height:	25
Height:	40½	Usable Seat Depth:	18¼
Seat Depth:	18½	Ship Weight:	26
Seat Width:	17¾	Cube:	13.8
Back Width:	17¼	COM:	1.0
Back Height:	17½	Weight Rating:	300 lbs.

FABRIC PRICE CODES

1	\$447	8	\$585
2	\$471	9	\$603
3	\$495	10	\$621
4	\$513	11	\$639
5	\$531	12	\$657
6	\$549	L	—
7	\$567		

HMG5

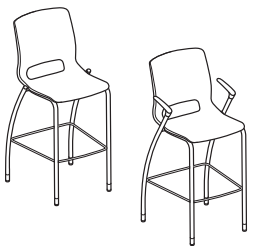

CAFÉ-HEIGHT STOOL

Four Legs

DIMENSIONS

Depth:	23	Arm Width:	18
Width:	21	Seat to Floor Height:	30
Height:	44½	Usable Seat Depth:	18½
Seat Depth:	18½	Ship Weight:	30
Seat Width:	17¾	Cube:	19.3
Back Width:	17¼	Weight Rating:	300 lbs.
Back Height:	18		

LIST PRICE

\$396

HMG7

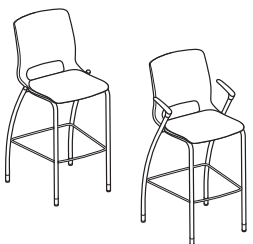

CAFÉ-HEIGHT STOOL

Four Legs
Upholstered Seat

DIMENSIONS

Depth:	23	Arm Width:	18
Width:	21	Seat to Floor Height:	30½
Height:	44½	Usable Seat Depth:	18¼
Seat Depth:	18½	Ship Weight:	34
Seat Width:	17¾	Cube:	19.3
Back Width:	17¼	COM:	1.0
Back Height:	17½	Weight Rating:	300 lbs.

FABRIC PRICE CODES

1	\$469	8	\$607
2	\$493	9	\$625
3	\$517	10	\$643
4	\$535	11	\$661
5	\$553	12	\$679
6	\$571	L	—
7	\$589		

HON Recommendation: HMG5.N.E.ON.PLAT - List Price \$396

HOW TO SPECIFY

Select Model Number	Select Arm Type	Select Glide	Select Shell Color	Select Fabric	Select Frame
F Fixed Arms (+ \$30 per chair) N Armless	E Standard Nylon Glide F Felt Glide (+ \$30 per chair) R Rubber Glide (+ \$30 per chair) T Steel Glide (+ \$30 per chair)	RG Tangelo CR Cherry LM Lime CP Calypso BU Surf RE Regatta MB Mulberry	LO Loft PT Platinum SD Shadow LA Lava ON Onyx WT White	See page 183 <i>Not specified for models HMG1 and HMG5</i>	See page 182
HMG5	N	E	ON		PLAT
HMG7	N	E	ON	CU10	PLAT

MOTIVATE® Nesting/Stacking Flex-Back Chair Options

MODEL OPTIONS

HMN1



Flex-back

Nesting/Stacking,
Four Legs

HMN2



Flex-back

Nesting/Stacking, Four
Legs, Upholstered Seat

ARM STYLE

CODE DESCRIPTION PRICE



F Fixed Arms **+\$50**



N Armless **+\$0**

CASTERS/ GLIDE

CODE DESCRIPTION PRICE



H Hard Caster **+\$0**



S Soft Caster **+\$20**



E Standard Nylon Glide **+\$0**

BACK STYLE

CODE DESCRIPTION PRICE

Plastic/Upholstered Options:



PS Plastic Shell **+\$0**



PB Upholstered **+\$70**

**PB only available on HMN2*

4-Way Stretch Options:



IM Black **+\$80**

IF Fog **+\$80**

IC Charcoal **+\$80**

IH Chai **+\$80**

IY Navy **+\$80**

FRAME

CODE DESCRIPTION PRICE

P1 PAINT: **+\$0**

BLCK Textured Black

P7J Textured Brownstone

P7A Textured Charcoal

PK7 Textured Designer White

P7L Textured Loft

P7M Textured Muslin

P8V Textured Titanium

P2 PAINT: **+\$0**

PLAT Textured Platinum
Metallic

PR8 Textured Silver

P3 PAINT: **+\$30**

P8S Atom

PJF Bullseye

P8P Ember

P8N Ion

P8J Iris

P8F Krypton

P8M Regatta

PLASTIC SHELL COLOR CODES (no upcharge): Tangelo - **RG** Cherry - **CR** Lime - **LM** Calypso - **CP** Surf - **BU**
Regatta - **RE** Mulberry - **MB** Loft - **LO** Platinum - **PT** Shadow - **SD**
Lava - **LA** Onyx - **ON** White - **WT**

1 For CA Technical Bulletin 133, Onyx (ON) shell color is available as a Standard Special through HON's Tailored Solutions program. Please see pages 26-29 or contact HON Customer Support for more information.

Nesting/Stacking Flex-Back Chair Fabric Options

HON BRANDED FABRICS

GRADE 1

Attire
Centurion
Compass
Contourett Polyurethane
Dapper
Hamilton
Inertia
Optic

GRADE 2

Appoint Seating
Clyde
Dotty
Rush
Seed
Spin Seating
Whisper Vinyl

GRADE 3

In Season
Purl
Silvertex™ Vinyl

For a complete list of fabrics, including partnership fabrics, go to hon.com/fabricsandfinishes.

Reference Fabric Color Combinations on pages 18-22 for color codes and legend on page 19 for lead times.

! For CA Technical Bulletin 133, Onyx (ON) shell color is available as a Standard Special through HON's Tailored Solutions program. Please see pages 26-29 or contact HON Customer Support for more information.

MOTIVATE® Nesting/Stacking Flex-Back Chairs

GSA SIN 33721



Icon Legend on page 15

HMN1

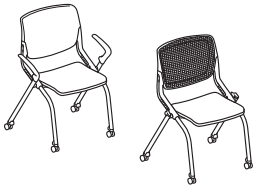

CHAIR

Flex-back
Nesting/Stacking
Four Legs

DIMENSIONS

Depth:	23 ¹ / ₈	Arm Width:	24
Width:	26 ³ / ₄	Seat to Floor Height:	18 ¹ / ₄
Height:	34	Usable Seat Depth:	16 ³ / ₄
Seat Depth:	16 ³ / ₄	Ship Weight:	27
Seat Width:	17	Cube:	15.1
Back Width:	19 ¹ / ₂	Weight Rating:	300 lbs.
Back Height:	19		

LIST PRICE

\$458

NOTES: Stack 4-high on floor.

! When selecting the mesh back option, frame around mesh is always black.

HMN2



CHAIR

Flex-back
Nesting/Stacking
Four Legs
Upholstered Seat

DIMENSIONS

Depth:	23 ¹ / ₈	Seat to Floor Height:	19 ¹ / ₄
Width:	26 ³ / ₄	Usable Seat Depth:	17
Height:	34	Ship Weight (upholstered back):	29
Seat Depth:	17	Ship Weight (plastic/mesh back):	28
Seat Width:	17 ³ / ₈	Cube (upholstered back):	15.1
Back Width:	19 ¹ / ₂	Cube (plastic/mesh back):	15.1
Back Height:	18 ³ / ₈	COM (upholstered back):	1.0
Arm Width:	24	COM (plastic/mesh back):	1.0
		Weight Rating:	300 lbs.

FABRIC PRICE CODES

1	\$522	8	\$660
2	\$546	9	\$678
3	\$570	10	\$696
4	\$588	11	\$714
5	\$606	12	\$732
6	\$624	L	—
7	\$642		

NOTES: Stack 4-high on floor.

! When selecting the mesh back option, frame around mesh is always black.

HON Recommendation: HMN1.N.H.IM.ON.CU__PLAT - List Price \$538

HOW TO SPECIFY

Select Model Number	Select Arm Type	Select Caster/Glide	Select Back Type	Select Shell Color	Select Fabric	Select Frame
<p>F Fixed Arms (+ \$50)</p> <p>N Armless</p>	<p>E Standard Nylon Glide</p> <p>H Hard Caster</p> <p>S Soft Caster (+ \$20)</p>	<p>PS Plastic Shell</p> <p>PB Upholstered (+ \$70)</p> <p><i>PB option available on HMN2 only</i></p> <p>4-Way Stretch options (+ \$80)</p> <p>IM Black</p> <p>IF Fog</p> <p>IC Charcoal</p> <p>IH Chai</p> <p>IY Navy</p>	<p>RG Tangelo</p> <p>CR Cherry</p> <p>LM Lime</p> <p>CP Calypso</p> <p>BU Surf</p> <p>RE Regatta</p> <p>MB Mulberry</p> <p>LO Loft</p> <p>PT Platinum</p> <p>SD Shadow</p> <p>LA Lava</p> <p>ON Onyx</p> <p>WT White</p>	<p>See page 187</p> <p><i>Specify for model HMN2 only</i></p>	<p>See page 186</p>	
<p>HMN1</p> <p>HMN2</p>	<p>N</p> <p>N</p>	<p>H</p> <p>H</p>	<p>IM</p> <p>PB</p>	<p>ON</p> <p>ON</p>	<p>CU10</p>	<p>PLAT</p> <p>PLAT</p>

MOTIVATE® Chair with Tablet Arm Options

MODEL OPTIONS

HMG1



with Tablet Arm

Four Legs

HMG2



with Tablet Arm

Four Legs, Upholstered Seat

CASTERS/ GLIDES



CODE	DESCRIPTION	PRICE
H	Hard Caster	+\$0



S	Soft Caster	+\$20
----------	-------------	--------------



E	Standard Nylon Glide	+\$0
F	Felt Glide	+\$30
R	Rubber Glide	+\$30
T	Steel Glide	+\$30

TABLET SIDE



CODE	DESCRIPTION	PRICE
RT	Right Side	+\$0
LT	Left Side	+\$0



TABLET COLOR

CODE	DESCRIPTION	PRICE
T	Black	+\$0
D	Natural Maple	+\$0

FRAME

CODE	DESCRIPTION	PRICE
P1 PAINT:		+\$0
BLCK	Textured Black	
P7J	Textured Brownstone	
P7A	Textured Charcoal	
PK7	Textured Designer White	
P7L	Textured Loft	
P7M	Textured Muslin	
P8V	Textured Titanium	
P2 PAINT:		+\$0
PLAT	Textured Platinum Metallic	
PR8	Textured Silver	
P3 PAINT:		+\$30
P8S	Atom	
PJF	Bullseye	
P8P	Ember	
P8N	Ion	
P8J	Iris	
P8F	Krypton	
P8M	Regatta	

PLASTIC SHELL COLOR CODES (no upcharge): Tangelo - **RG** Cherry - **CR** Lime - **LM** Calypso - **CP** Surf - **BU**
 Regatta - **RE** Mulberry - **MB** Loft - **LO** Platinum - **PT** Shadow - **SD**
 Lava - **LA** Onyx - **ON** White - **WT**

! For CA Technical Bulletin 133, Onyx (ON) shell color is available as a Standard Special through HON's Tailored Solutions program. Please see pages 26-29 or contact HON Customer Support for more information.

MOTIVATE[®]

Chair with Tablet Arm Fabric Options

HON BRANDED FABRICS

GRADE 1

Attire
Centurion
Compass
Contourett Polyurethane
Dapper
Hamilton
Inertia
Optic

GRADE 2

Appoint Seating
Clyde
Doty
Rush
Seed
Spin Seating
Whisper Vinyl

GRADE 3

In Season
Purl
Silvertex™ Vinyl

For a complete list of fabrics, including partnership fabrics, go to hon.com/fabricsandfinishes.

Reference Fabric Color Combinations on pages 18-22 for color codes and legend on page 19 for lead times.

ⓘ For CA Technical Bulletin 133, Onyx (ON) shell color is available as a Standard Special through HON's Tailored Solutions program. Please see pages 26-29 or contact HON Customer Support for more information.



Icon Legend on page 15

MOTIVATE® Chair with Tablet Arm

HMGT1

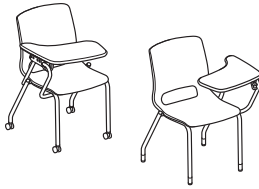

CHAIR

with Tablet Arm
Four Legs

DIMENSIONS

Depth:	30	Back Width:	17¼
Width:	21	Back Height:	18
Height:	32¼	Seat to Floor Height:	17¾
Seat Depth:	18¼	Tablet Height from Floor:	28¾
Seat Width:	17¾	Ship Weight:	41
		Cube:	18.4
		Weight Rating:	300 lbs.

LIST PRICE PER CARTON

\$505

NOTES: Tablet can be specified on right or left side.

HMGT2

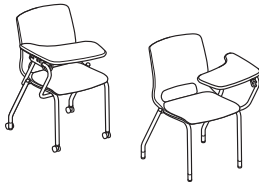

CHAIR

with Tablet Arm
Four Legs
Upholstered Seat

DIMENSIONS

Depth:	30	Back Width:	17¼
Width:	21	Back Height:	17½
Height:	32¼	Seat to Floor Height:	18¼
Seat Depth:	18¼	Tablet Height from Floor:	28¾
Seat Width:	17¾	Ship Weight:	43
		Cube:	18.4
		Weight Rating:	300 lbs.

FABRIC PRICE CODES

1	\$574	8	\$712
2	\$598	9	\$730
3	\$622	10	\$748
4	\$640	11	\$766
5	\$658	12	\$784
6	\$676	L	—
7	\$694		

NOTES: Tablet can be specified on right or left side.

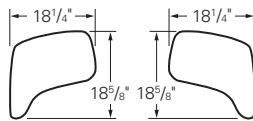

HON Recommendation: HMGT1.E.ON.RT.D.PLAT - List Price \$505

HOW TO SPECIFY

Select Model Number	Select Caster/Glide	Select Shell Color	Select Fabric	Select Tablet Side	Select Tablet Color	Select Frame
H S E F R T	H Hard Caster S Soft Caster (+ \$20 per chair) E Standard Nylon Glide F Felt Glide (+ \$30 per chair) R Rubber Glide (+ \$30 per chair) T Steel Glide (+ \$30 per chair)	RG Tangelo CR Cherry LM Lime CP Calypso BU Surf RE Regatta MB Mulberry LO Loft PT Platinum SD Shadow LA Lava ON Onyx WT White	See page 190 <i>Not specified for HMGT1 models</i>	RT Right Side LT Left Side	T Black D Natural Maple	See page 189
HMGT1	E	ON		RT	D	PLAT
HMGT2	E	ON	CU10	RT	D	PLAT

MOTIVATE® Flex-Back Chair with Tablet Arm Options

MODEL OPTIONS

HMNT1



Flex-back with Tablet Arm

HMNT2



Flex-back with Tablet Arm

Upholstered Seat

CASTERS/ GLIDE



CODE	DESCRIPTION	PRICE
H	Hard Caster	+\$0



S	Soft Caster	+\$20
----------	-------------	--------------



E	Standard Nylon Glide	+\$0
----------	----------------------	-------------

TABLET SIDE



CODE	DESCRIPTION	PRICE
RT	Right Side	+\$0
LT	Left Side	+\$0



BACK STYLE



CODE	DESCRIPTION	PRICE
<i>Plastic/Upholstered Options:</i>		
PS	Plastic Shell	+\$0



PB	Upholstered	+\$70
-----------	-------------	--------------



4-Way Stretch Options:

IM	Black	+\$80
IF	Fog	+\$80
IC	Charcoal	+\$80
IH	Chai	+\$80
IY	Navy	+\$80

TABLET COLOR

CODE	DESCRIPTION	PRICE
T	Black	+\$0
D	Natural Maple	+\$0

FRAME

CODE	DESCRIPTION	PRICE
P1 PAINT:		+\$0
BLCK	Textured Black	
P7J	Textured Brownstone	
P7A	Textured Charcoal	
PK7	Textured Designer White	
P7L	Textured Loft	
P7M	Textured Muslin	
P8V	Textured Titanium	
P2 PAINT:		+\$0
PLAT	Textured Platinum Metallic	
PR8	Textured Silver	
P3 PAINT:		+\$30
P8S	Atom	
PJF	Bullseye	
P8P	Ember	
P8N	Ion	
P8J	Iris	
P8F	Krypton	
P8M	Regatta	

PLASTIC SHELL COLOR CODES (no upcharge): Tangelo - **RG** Cherry - **CR** Lime - **LM** Calypso - **CP** Surf - **BU**
 Regatta - **RE** Mulberry - **MB** Loft - **LO** Platinum - **PT** Shadow - **SD**
 Lava - **LA** Onyx - **ON** White - **WT**

! For CA Technical Bulletin 133, Onyx (ON) shell color is available as a Standard Special through HON's Tailored Solutions program. Please see pages 26-29 or contact HON Customer Support for more information.

Flex-Back Chair with Tablet Arm Fabric Options

HON BRANDED FABRICS

GRADE 1

Attire
Centurion
Compass
Contourett Polyurethane
Dapper
Hamilton
Inertia
Optic

GRADE 2

Appoint Seating
Clyde
Dotty
Rush
Seed
Spin Seating
Whisper Vinyl

GRADE 3

In Season
Purl
Silvertex™ Vinyl

For a complete list of fabrics, including partnership fabrics, go to hon.com/fabricsandfinishes.

Reference Fabric Color Combinations on pages 18-22 for color codes and legend on page 19 for lead times.

ⓘ For CA Technical Bulletin 133, Onyx (ON) shell color is available as a Standard Special through HON's Tailored Solutions program. Please see pages 26-29 or contact HON Customer Support for more information.

MOTIVATE[®] Flex-Back Chair with Tablet Arm

GSA SIN 33721



Icon Legend on page 15

HMNT1

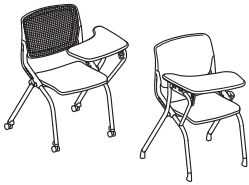

CHAIR

Flex-back with Tablet Arm

DIMENSIONS

Depth:	30 ³ / ₈	Seat to Floor Height:	18 ¹ / ₄
Width:	23 ¹ / ₂	Tablet Height from Floor:	29 ¹ / ₂
Height:	34	Ship Weight:	41
Seat Depth:	17 ¹ / ₄	Cube:	18.4
Seat Width:	17	Weight Rating:	300 lbs.
Back Width:	19 ¹ / ₂		
Back Height:	19		

LIST PRICE

\$693

NOTES: Tablet can be specified on right or left side.

! Model HMNT1 is not available with an upholstered back.

HMNT2

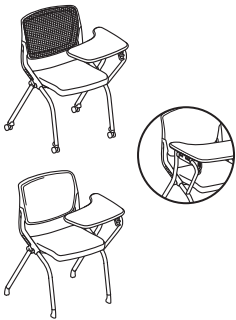

CHAIR

Flex-back with Tablet Arm
Upholstered Seat

DIMENSIONS

Depth:	30 ³ / ₈	Seat to Floor Height:	19 ¹ / ₄
Width:	23 ¹ / ₂	Tablet Height from Floor:	29 ¹ / ₂
Height:	34	Ship Weight:	42
Seat Depth:	17 ⁵ / ₈	Cube:	18.4
Seat Width:	17 ⁵ / ₈	Weight Rating:	300 lbs.
Back Width:	19 ¹ / ₂		
Back Height:	18 ⁵ / ₈		

FABRIC PRICE CODES

1	\$763	8	\$901
2	\$787	9	\$919
3	\$811	10	\$937
4	\$829	11	\$955
5	\$847	12	\$973
6	\$865	L	—
7	\$883		

NOTES: Tablet can be specified on right or left side.

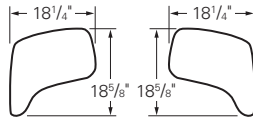

HON Recommendation: HMNT1.E.IM.ON.RT.D.PLAT - List Price \$773

HOW TO SPECIFY

Select Model Number	Select Caster/Glide	Select Back Type	Select Shell Color	Select Fabric	Select Tablet Side	Select Tablet Color	Select Frame
E Standard Nylon Guide H Hard Caster S Soft Caster (+ \$20)	PS Plastic Shell PB Upholstered (+ \$70) <i>PB option not available on HMNT1</i> 4-Way Stretch options (+ \$80) IM Black IF Fog IC Charcoal IH Chai IY Navy	RG Tangelo CR Cherry LM Lime CP Calypso BU Surf RE Regatta MB Mulberry LO Loft PT Platinum SD Shadow LA Lava ON Onyx WT White	See page 193 <i>Specify for model HMNT2 only</i>	RT Right Side LT Left Side	T Black D Natural Maple	See page 192	
HMNT1	E	IM	ON		RT	D	PLAT
HMNT2	E	PB	ON	CU10	RT	D	PLAT



HVL281



LOW-BACK TASK CHAIR

Upholstered
Swivel-tilt
Armless
Functions: **A, E, F, K, L**
(Function Key on pages 16-17)

DIMENSIONS

Depth:	25½	Back Width:	17¾
Width:	25½	Back Height:	17¾
Height:	37½	Seat to Floor Height:	17-21½
Seat Depth:	16½	Ship Weight:	27.9
Seat Width:	18½	Cube:	4.3
		Weight Rating:	250 lbs.

LIST PRICE

\$249

NOTES: **HON 5-Year Limited Warranty.**

HON Recommendation: HVL281.Z1.VA10.T - List Price \$249

HVL282



MID-BACK TASK CHAIR

Upholstered
Swivel-tilt
Height and Width Adjustable
Arms
Height-adjustable Back
Functions: **A, B, E, F, K, L, S**
(Function Key on pages 16-17)

DIMENSIONS

Depth:	25¼	Arm Width:	18½
Width:	26½	Seat to Floor Height:	18¾-22¾
Height:	43¾	Ship Weight:	47.0
Seat Depth:	16¾	Cube:	6.0
Seat Width:	19⅞	Weight Rating:	250 lbs.
Back Width:	19⅞		
Back Height:	20½		

LIST PRICE

Swivel-tilt	\$382
Asynchronous	\$437

NOTES: **HON 5-Year Limited Warranty.**

HON Recommendation: HVL282.Z1.VA10.T - List Price \$382

HVL283



HIGH-BACK TASK CHAIR

Upholstered
Asynchronous with Seat Slide
Height and Width Adjustable
Arms
Functions: **A, D, E, O, S**
(Function Key on pages 16-17)

DIMENSIONS

Depth:	25¼	Arm Width:	17¾
Width:	26½	Seat to Floor Height:	18¾-22¾
Height:	47¼	Ship Weight:	53.3
Seat Depth:	17⅞	Cube:	6.9
Seat Width:	19⅞	Weight Rating:	250 lbs.
Back Width:	20⅞		
Back Height:	23⅞		

LIST PRICE

\$535

NOTES: **HON 5-Year Limited Warranty.**

HON Recommendation: HVL283.A2.VA10.T - List Price \$535

HVL289



ADJUSTABLE ARM PACK

Height and Width
Available in Black (T)
Functions: **S**
(Function Key on pages 16-17)

DIMENSIONS

Adjustable Arm Width:	18¼
Height from Seat:	7⅞-10⅞
Ship Weight:	9.8
Cube:	0.8

LIST PRICE

\$77

HON Recommendation: HVL289.T - List Price \$77

HOW TO SPECIFY

<p>Select Model Number</p> <p>H V L 2 8 1 .</p>	<p>Select Control</p> <p>Z1 Swivel Tilt Available on HVL281 and HVL282 only</p> <p>A2 Asynchronous with Seat Slide Available on HVL282 and HVL283 only</p> <p>Z 1 .</p>	<p>Select Fabric</p> <p>VA10 Black Fabric</p> <p>V A 1 0 .</p>	<p>Select Frame</p> <p>T Black</p> <p>T</p>
--	--	--	---

NEUTRALIZE™



Neutralize™ Mesh Task Chair with Empower® Desks and Fuse™ Storage.

NEUTRALIZE™

Don't adjust your sitting preferences to fit your chair, make it fit your needs. Neutralize™ adjusts practically everywhere to perfectly fit your body and your work style. The breathable mesh back is made up of three articulating sections to fit anyone, including an adjustable headrest. The synchro-tilt control and fully adjustable arms support your body in any posture or position.



FEATURES

- Contemporary segmented mesh back enhancing support and increasing airflow.
- Height, width, depth, and pivot arms provide support right where you want it.
- Adjustable headrest delivers executive-level comfort.
- Mesh seat and seat slide conform to your body to reduce pressure points.
- HON 5-Year Limited Warranty.



NEUTRALIZE™ Mesh Chair

HVL791



MESH TASK CHAIR

Pneumatic
Swivel
Synchronized Tilt
Tilt Tension
Tilt Lock
Seat Glide Mechanism
Adjustable Headrest
All-Adjustable Arms

Functions: **A, D, E, J, K, L, B-A**
(Function Key on pages 16-17)

DIMENSIONS

Depth:	29½	Arm Width:	3½
Width:	28¾	Seat to Floor Height:	18¾-22¾
Height:	53	Usable Seat Depth:	18½
Seat Depth:	19¾	Ship Weight:	47.5 Ⓢ
Seat Width:	19¾	Cube:	7.8
Back Width:	20	Weight Rating:	250 lbs.
Back Height:	28¾		

LIST PRICE

\$660

NOTES: Comfortable and breathable mesh seat and back. Black frame with subtle chrome accents. Adjustable seat glide mechanism. Height, width, depth and pivot adjustable arms. Adjustable headrest. **HON 5-Year Limited Warranty.**

HON Recommendation: HVL791.BM.SB - List Price \$660

HOW TO SPECIFY

Select
Model Number

H V L 7 9 1

Select
Fabric

BM Black Mesh

B M

Select
Base

SB Standard Base

S B

NUCLEUS®



Nucleus Work Chairs shown with Preside® Conference Table.

NUCLEUS®

Enjoy seating that delivers comfort from the inside out. Nucleus task and guest chairs adapt to everyone's unique body types to create a custom fit and targeted support. The back flexes with the spine. The seat cradles you like a hammock. The sophisticated aesthetic makes a stylish statement. Nucleus is the powerhouse seating family that brings cool and comfortable together.



GUEST CHAIR FEATURES

- Stacking chairs stack up to four high on the floor.
- HN6 guest chair available with glides, hard or soft casters.
- Available in hundreds of quality HON fabrics.
- Warranted for users up to 300 lbs.

TASK CHAIR FEATURES

- Advanced suspension material in the seat combines with molded foam to create unparalleled support.
- Choose between the 4-Way Stretch mesh back or an upholstered suspension back.
- 4-Way Stretch mesh back is available in five colors.
- Choose between armless, fixed arms or height- and width-adjustable arms.
- Responsive synchro-tilt control provides a smooth, natural recline.
- Available in Black or Polished Aluminum base.
- Tilt tension controls the rate and ease of recline.
- Tilt lock allows the user to lock the back in multiple recline positions.
- Available in hundreds of quality HON fabrics.
- Warranted for users up to 300 lbs.

NUCLEUS® Task Chair Options

MODEL OPTIONS

HN1



Task Chair (4-Way Stretch Back)

Pneumatic, Swivel, Seat Glide, Synchro-tilt, Tilt Tension, Tilt Lock, Armless

HN1U



Task Chair (Upholstered Back)

Pneumatic, Swivel, Seat Glide, Synchro-tilt, Tilt Tension, Tilt Lock, Armless

ARM STYLE

CODE	DESCRIPTION	PRICE
N	Armless	+\$0
A	Height and Width Adjustable Arms	+\$75
P	Fixed Arms - Polished	+\$150

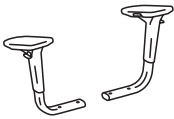

BASE

CODE	DESCRIPTION	PRICE
SB	Standard Base	+\$0
PA	Polished Aluminum	+\$110

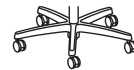

CASTERS

CODE	DESCRIPTION	PRICE
H	Hard Caster	+\$0
S	Soft Caster	+\$30



FRAME

CODE	DESCRIPTION	PRICE
T	Black	+\$0

BACK STYLE

CODE	DESCRIPTION	PRICE
<i>4-Way Stretch mesh back options:</i>		
IM	Black	+\$0
IF	Fog	+\$0
IC	Charcoal	+\$0
IH	Chai	+\$0
IY	Navy	+\$0

NUCLEUS® Multi-Purpose and Café Chair Options

MODEL OPTIONS

HN6



**Multi-Purpose Stack Chair
(4-Way Stretch Back)**

Four Legs



HN7



**Café-Height Stool (4-Way Stretch
Back)**

Four Legs

ARM STYLE	CODE	DESCRIPTION	PRICE
	N	Armless	+\$0
	F	Fixed Arms	+\$30

CASTERS/ GLIDE	CODE	DESCRIPTION	PRICE
	H	Hard Caster <i>*Not available on HN7</i>	+\$0
	S	Soft Caster <i>*Not available on HN7</i>	+\$20
	E	Glide	+\$0

BACK STYLE	CODE	DESCRIPTION	PRICE
<i>4-Way Stretch mesh back options:</i>			
IM		Black	+\$0
IF		Fog	+\$0
IC		Charcoal	+\$0
IH		Chai	+\$0
IY		Navy	+\$0

FRAME	CODE	DESCRIPTION	PRICE
T		Black	+\$0
T1		Platinum Metallic	+\$0

HON BRANDED FABRICS

GRADE 1

Attire
Centurion
Compass
Contourett Polyurethane
Dapper
Hamilton
Inertia
Optic

GRADE 2

Appoint Seating
Clyde
Dotty
Rush
Seed
Spin Seating
Whisper Vinyl

GRADE 3

In Season
Purl
Silvertex™ Vinyl

GRADE L

Denver Leather*

For a complete list of fabrics, including partnership fabrics, go to hon.com/fabricsandfinishes.

Reference Fabric Color Combinations on pages 18-22 for color codes and legend on page 19 for lead times. For additional HON to Supply COM fabric grade pricing, go to honready.hon.com and click on the HON to Supply COM link.

*Denver Leather (SS) may not be available on every model within a specific series, please refer to the model's page for details.

 For Fire Code model, availability and ordering method, refer to pages 26-29. Available on select models, contact HON Customer Support for availability.



Icon Legend on page 15

HN1



TASK CHAIR

4-Way Stretch Back

- Pneumatic
- Swivel
- Seat Glide
- Synchro-tilt
- Tilt Tension
- Tilt Lock
- Armless

Functions:

A, D, E, A-C, A-D, J, L

(Function Key on pages 16-17)

HON Recommendation: HN1.A.H.IM.CU__SB.T - List Price \$931

DIMENSIONS

Depth:	25¾	Arm Width:	17-20
Width:	28¾	Seat to Floor Height:	17-22
Height:	45¼	Usable Seat Depth:	16½-19
Seat Depth:	20	Ship Weight:	52
Seat Width:	20	Cube:	11.3
Back Width:	19¼	COM:	1.0
Back Height:	25¼	Weight Rating:	300 lbs.

FABRIC PRICE CODES

1	\$856	8	\$994
2	\$880	9	\$1012
3	\$904	10	\$1030
4	\$922	11	\$1048
5	\$940	12	\$1066
6	\$958	L	\$1056
7	\$976		

HOW TO SPECIFY

Select Model Number	Select Arm Type	Select Caster/Glide	Select Back Type	Select Fabric	Select Base	Select Frame
	N Armless A Height and Width Adjustable Arms (+ \$75) P Fixed Arms - Polished (+ \$150)	H Hard Caster S Soft Caster (+ \$30)	4-Way Stretch options IM Black IF Fog IC Charcoal IH Chai IY Navy	See page 201	SB Standard Base PA Polished Aluminum (+ \$110)	See page 199 T Black
HN1	A	H	IM	CU10	SB	T

HN1U



TASK CHAIR

Upholstered Back

- Pneumatic
- Swivel
- Seat Glide
- Synchro-tilt
- Tilt Tension
- Tilt Lock
- Armless

Functions:

A, D, E, A-C, A-D, J, L

(Function Key on pages 16-17)

HON Recommendation: HN1U.A.H.CU__SB.T - List Price \$931

DIMENSIONS

Depth:	26	Arm Width:	19⅞
Width:	28¾	Seat to Floor Height:	17-22
Height:	44¼	Usable Seat Depth:	16-18½
Seat Depth:	20	Ship Weight:	49
Seat Width:	20	Cube:	12.6
Back Width:	18¼	COM:	2.0
Back Height:	25½	Weight Rating:	300 lbs.

FABRIC PRICE CODES

1	\$856	8	\$1132
2	\$904	9	\$1168
3	\$952	10	\$1204
4	\$988	11	\$1240
5	\$1024	12	\$1276
6	\$1060	L	\$1256
7	\$1096		

HOW TO SPECIFY

Select Model Number	Select Arm Type	Select Caster/Glide	Select Fabric	Select Base	Select Frame
	N Armless A Height and Width Adjustable Arms (+ \$75) P Fixed Arms - Polished (+ \$150)	H Hard Caster S Soft Caster (+ \$30)	See page 201	SB Standard Base PA Polished Aluminum (+ \$110)	See page 199 T Black
HN1U	A	H	CU10	SB	T



Icon Legend on page 15

HN6

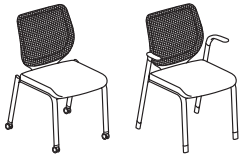

MULTI-PURPOSE STACK CHAIR

4-Way Stretch Back
Four Legs

DIMENSIONS

Depth:	26¼	Arm Width:	21½
Width:	27	Seat to Floor Height:	18½
Height:	37½	Usable Seat Depth:	18½
Seat Depth:	19	Ship Weight:	31
Seat Width:	19	Cube:	15.2
Back Width:	18	COM:	1.0
Back Height:	18½	Weight Rating:	300 lbs.

FABRIC PRICE CODES

1	\$525	8	\$663
2	\$549	9	\$681
3	\$573	10	\$699
4	\$591	11	\$717
5	\$609	12	\$735
6	\$627	L	—
7	\$645		

HN7

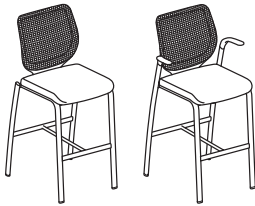

CAFÉ-HEIGHT STOOL

4-Way Stretch Back
Four Legs

DIMENSIONS

Depth:	24½	Arm Width:	21½
Width:	25	Seat to Floor Height:	30
Height:	46½	Usable Seat Depth:	18½
Seat Depth:	19	Ship Weight:	40
Seat Width:	19	Cube:	21.4
Back Width:	18	COM:	1.0
Back Height:	18½	Weight Rating:	300 lbs.

FABRIC PRICE CODES

1	\$571	8	\$709
2	\$595	9	\$727
3	\$619	10	\$745
4	\$637	11	\$763
5	\$655	12	\$781
6	\$673	L	—
7	\$691		

HON Recommendation: HN6.F.H.IM.CU__T - List Price \$555

HOW TO SPECIFY

Select Model Number HN6	Select Arm Type F Fixed Arms (+ \$30) N Armless	Select Caster/Glide E Glide H Hard Caster S Soft Caster (+ \$20) <i>Casters available on HN6 only</i>	Select Back Type 4-Way Stretch options IM Black IF Fog IC Charcoal IH Chai IY Navy	Select Fabric See page 201	Select Frame T Black T1 Platinum Metallic
---------------------------------------	--	--	---	--------------------------------------	--

HNATA

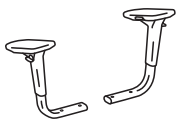

ADJUSTABLE ARM PACK

Height and Width
Functions: S
(Function Key on pages 16-17)

DIMENSIONS

Arm Width:	17-20
Height from Seat:	6¼-10¼
Ship Weight:	7.5 S
Cube:	1.0

LIST PRICE

\$122

HNFPA



POLISHED ALUMINUM ARM PACK

Fixed Height

DIMENSIONS

Arm Width:	19¾
Height from Seat:	7¼
Ship Weight:	7.5 S
Cube:	1.0

LIST PRICE

\$191

OPEN MARKET

HOW TO SPECIFY

Select Model Number HNATA

HIGH-DENSITY OLSON STACKER® 4040 SERIES



Olson Stacker.

HIGH-DENSITY OLSON STACKER® 4040 SERIES

Adaptable spaces such as multi-purpose and training areas demand a chair equally flexible. Olson stacking chairs fit that bill with a lightweight frame that is easy to move throughout a space. Chairs stack up to 12 high on the floor or up to 40 high on their specially designed cart to maximize floor space when not in use. A convenient cutout in the back makes it easy to pick up and move, while the molded seat shells deliver surprising comfort. Olson stacking chairs ship in sets of four to accommodate large groups. With Olson, the benefits really stack up.



FEATURES

- Chairs ship four per carton.
- Contoured seat and back shell provide targeted support.
- Integrated lumbar support delivers long-lasting comfort.
- Integrated handle makes chair easy to carry.
- Optional ganging brackets connect chairs to form neat rows.
- Stacks up to 12 high without cart.
- Stacks up to 40 high on cart.
- Shell colors are CA Technical Bulletin 133 compliant.
- Warranted for users up to 300 lbs.



HIGH-DENSITY OLSON STACKER® 4040 Series

H4041



POLYMER SEAT AND BACK DIMENSIONS

7/16" Steel Rod Frame
Chrome Legs

Depth:	21 5/8	Seat to Floor Height:	17 3/4
Width:	19 1/8	Usable Seat Depth:	17
Height:	30 5/8	Ship Weight:	57 Ⓢ
Seat Depth:	18 1/4	Cube:	10.6
Seat Width:	17 3/4	Weight Rating:	300 lbs.
Back Width:	17 1/2		
Back Height:	16 1/4		

LIST PRICE PER CARTON

\$697
(reference single unit @
\$174.25

+ 4040 Series is ordered and shipped four (4) chairs per carton. Pricing shown is per carton. Each set of four (one carton), must have the same shell color. Ordering 2 of Model H4041 will result in 2 cartons being shipped, giving you 8 chairs.

! Shipped fully assembled — 4 chairs per carton. All High-Density Olson Stacker® shell colors are CA Technical Bulletin 133 compliant (no upcharge).

🔥 For Fire Code model, availability and ordering method, refer to pages 26-29.

H4043

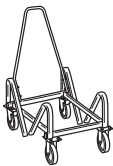

CART FOR STACKING CHAIRS

DIMENSIONS

Depth:	35 1/2	Ship Weight:	34 Ⓢ
Width:	21 5/8	Cube:	7.8
Height:	37		

LIST PRICE

\$485

NOTES: Holds 40 stack chairs (6'-8"), some assembly required. (Chairs stack 12 high without cart.)

! Specify Black paint (T) ONLY.

H4048

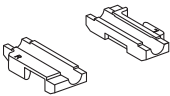

GANGING CHAIR GLIDES

DIMENSIONS

Box of 48	Ship Weight:	1 Ⓢ
For use on models H4041, HG51 and HG52	Cube:	0.04

LIST PRICE

\$125

H4049

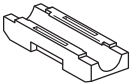

NON-GANGING CHAIR GLIDES

DIMENSIONS

Box of 48	Ship Weight:	1 Ⓢ
For use on models H4041, HFLEX01, HG51 and HG52	Cube:	0.04

LIST PRICE

\$98

HOW TO SPECIFY

<p>Select Model Number</p> <p>H 4 0 4 1 .</p>	<p>Select Shell Color</p> <table border="0"> <tr> <td>RG Tangelo</td> <td>LO Loft</td> </tr> <tr> <td>CR Cherry</td> <td>PT Platinum</td> </tr> <tr> <td>LM Lime</td> <td>SD Shadow</td> </tr> <tr> <td>CP Calypso</td> <td>LA Lava</td> </tr> <tr> <td>BU Surf</td> <td>ON Onyx</td> </tr> <tr> <td>RE Regatta</td> <td>WT White</td> </tr> <tr> <td>MB Mulberry</td> <td></td> </tr> </table> <p>ON .</p>	RG Tangelo	LO Loft	CR Cherry	PT Platinum	LM Lime	SD Shadow	CP Calypso	LA Lava	BU Surf	ON Onyx	RE Regatta	WT White	MB Mulberry		<p>Select Frame</p> <p>Y Chrome</p> <p>Y</p>
RG Tangelo	LO Loft															
CR Cherry	PT Platinum															
LM Lime	SD Shadow															
CP Calypso	LA Lava															
BU Surf	ON Onyx															
RE Regatta	WT White															
MB Mulberry																

PAGODA®



Pagoda Guest Chairs
and Café Stools.

PAGODA®

Roll out the welcome mat with Pagoda guest chairs. Reception areas. Private offices. Anywhere in between. Pagoda is a coordinated, versatile collection of stacking chairs and stools that easily match any environment and offer comfort for any type of activity. Standard-height chairs stack up to five high to clear valuable floor space whenever needed. Counter-height stools are great for cafés or common areas. Wherever comfort and style are equally important, Pagoda will create the look and feel you need.



FEATURES

- Guest chairs stack up to five high on the floor.
- Fully-upholstered outer back.
- Molded seat underpan protects seat fabric and creates a finished appearance when stacked.
- Optional fixed arms are gently sloped for maximum comfort.
- Tube rolled steel frame adds durability.
- Create a contemporary mixed material aesthetic.
- Optional wood veneer back is available in five attractive finishes.
- Available in hundreds of quality HON fabrics.
- Warranted for users up to 250 lbs.

MODEL OPTIONS

H4071



Stacking Arm Guest Chairs
Set of Two

H4073



Stacking Armless Guest Chairs
Set of Two

H4075



Stacking Arm Guest Chairs
Set of Two

H4077



Mobile Stacking Armless Guest Chairs
Set of Two

H4091



Stacking Arm Guest Chairs (Wood Back)
Set of Two

H4093



Stacking Armless Guest Chairs (Wood Back)
Set of Two

H4095



Stacking Arm Guest Chairs (Wood Back)
Set of Two

H4097



Mobile Stacking Armless Guest Chairs (Wood Back)
Set of Two

H4099

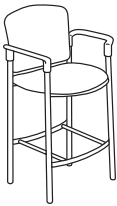

Café-Height Stool (Wood Back)
Footrest, Arms

H4079



Café-Height Stool (Upholstered Back)
Footrest, Arms

PAGODA® Options

CASTERS



CODE	DESCRIPTION	PRICE
H	Hard Caster	+\$0



S	Soft Caster	+\$20
----------	-------------	--------------

*Specify for models H4075 and H4077 only

FINISH

CODE	DESCRIPTION	PRICE
C	Harvest	+\$0
D	Natural Maple	+\$0
F	Shaker Cherry	+\$0
H	Bourbon Cherry	+\$0
N	Mahogany	+\$0

*Specify for models H4091, H4093, H4095, H4097 and H4099 only

FRAME

CODE	DESCRIPTION	PRICE
T	Black	+\$0
T1	Platinum Metallic	+\$0

HON BRANDED FABRICS

GRADE 1

Attire
Centurion
Compass
Contourett Polyurethane
Dapper
Hamilton
Inertia
Optic

GRADE 2

Appoint Seating
Clyde
Dotty
Rush
Seed
Spin Seating
Whisper Vinyl

GRADE 3

In Season
Purl
Silvertex™ Vinyl

For a complete list of fabrics, including partnership fabrics, go to hon.com/fabricsandfinishes.

**Pagoda® wood back models available in Harvest (C), Natural Maple (D), Shaker Cherry (F), Bourbon Cherry (H) and Mahogany (N) only.

Reference Fabric Color Combinations on pages 18-22 for color codes and legend on page 19 for lead times. For additional HON to Supply COM fabric grade pricing, go to honready.hon.com and click on the HON to Supply COM link.

For Fire Code model, availability and ordering method, refer to pages 26-29. Available on select models, contact HON Customer Support for availability.



PAGODA® 4070 Series

H4071



STACKING ARM GUEST CHAIRS

Set of Two

DIMENSIONS

Depth:	22½	Arm Width:	23¾
Width:	27¼	Seat to Floor Height:	18
Height:	33	Usable Seat Depth:	16¾
Seat Depth:	19¾	Ship Weight:	56
Seat Width:	20¼	Cube:	19.6
Back Width:	21¼	COM (per 2 pack):	2.5
Back Height:	16¼	Weight Rating:	250 lbs.

FABRIC PRICE CODES

	Per Carton List Price	Single Unit List Price
1	\$947	\$473.50
2	\$995	\$497.50
3	\$1043	\$521.50
4	\$1079	\$539.50
5	\$1115	\$557.50
6	\$1151	\$575.50
7	\$1187	\$593.50
8	\$1223	\$611.50
9	\$1259	\$629.50
10	\$1295	\$647.50
11	\$1331	\$665.50
12	\$1367	\$683.50
L	—	—

NOTES: Use Model H4069 Ganging Connectors on page 213. Ships two to a container. See shipping notes on page 210.

H4073



STACKING ARMLESS GUEST CHAIRS

Set of Two

DIMENSIONS

Depth:	22½	Seat to Floor Height:	18
Width:	21¼	Usable Seat Depth:	16¾
Height:	33	Ship Weight:	52
Seat Depth:	19¾	Cube:	18.9
Seat Width:	20¼	COM (per 2 pack):	2.5
Back Width:	21¼	Weight Rating:	250 lbs.
Back Height:	16¼		

FABRIC PRICE CODES

	Per Carton List Price	Single Unit List Price
1	\$883	\$441.50
2	\$931	\$465.50
3	\$979	\$489.50
4	\$1015	\$507.50
5	\$1051	\$525.50
6	\$1087	\$543.50
7	\$1123	\$561.50
8	\$1159	\$579.50
9	\$1195	\$597.50
10	\$1231	\$615.50
11	\$1267	\$633.50
12	\$1303	\$651.50
L	—	—

NOTES: Use Model H4069 Ganging Connectors on page 213. Ships two to a container. See shipping notes on page 210.

HOW TO SPECIFY

<p>Select Model Number</p> <div style="border: 1px solid #ccc; padding: 5px; display: flex; justify-content: space-between; align-items: center;"> H 4 0 7 1 • </div>	<p>Select Fabric</p> <p>See page 208</p> <div style="border: 1px solid #ccc; padding: 5px; display: flex; justify-content: space-between; align-items: center;"> C U 1 0 • </div>	<p>Select Frame</p> <p>T Black T1 Platinum Metallic</p> <div style="border: 1px solid #ccc; padding: 5px; display: flex; justify-content: space-between; align-items: center;"> T • </div>
--	--	---

PAGODA® 4070 Series

GSA SIN 33721



Icon Legend on page 15

H4075



STACKING ARM GUEST CHAIRS

Set of Two

DIMENSIONS

Depth:	22½	Arm Width:	23¾
Width:	27¼	Seat to Floor Height:	18
Height:	33	Usable Seat Depth:	16¾
Seat Depth:	19¾	Ship Weight:	56
Seat Width:	20¼	Cube:	19.6
Back Width:	21¼	COM (per 2 pack):	2.5
Back Height:	16¼	Weight Rating:	250 lbs.

FABRIC PRICE CODES

	Per Carton List Price	Single Unit List Price
1	\$1061	\$530.50
2	\$1109	\$554.50
3	\$1157	\$578.50
4	\$1193	\$596.50
5	\$1229	\$614.50
6	\$1265	\$632.50
7	\$1301	\$650.50
8	\$1337	\$668.50
9	\$1373	\$686.50
10	\$1409	\$704.50
11	\$1445	\$722.50
12	\$1481	\$740.50
L	—	—

H4077



MOBILE STACKING ARMLESS GUEST CHAIRS

Set of Two

DIMENSIONS

Depth:	22½	Seat to Floor Height:	18
Width:	21¼	Usable Seat Depth:	16¾
Height:	33	Ship Weight:	56
Seat Depth:	19¾	Cube:	19.5
Seat Width:	20¼	COM (per 2 pack):	2.5
Back Width:	21¼	Weight Rating:	250 lbs.
Back Height:	16¼		

FABRIC PRICE CODES

	Per Carton List Price	Single Unit List Price
1	\$999	\$499.50
2	\$1047	\$523.50
3	\$1095	\$547.50
4	\$1131	\$565.50
5	\$1167	\$583.50
6	\$1203	\$601.50
7	\$1239	\$619.50
8	\$1275	\$637.50
9	\$1311	\$655.50
10	\$1347	\$673.50
11	\$1383	\$691.50
12	\$1419	\$709.50
L	—	—

4070 Series is ordered and shipped two (2) chairs per carton. Pricing shown is per carton. Each set of two (one carton), must have the same fabric/frame color. (COM yardage shown is for two chairs.) Ordering 2 of any model will result in 2 cartons being shipped, giving you 4 chairs.

HOW TO SPECIFY

<p>Select Model Number</p> <p>H 4 0 7 5 .</p>	<p>Select Caster</p> <p>H Hard Caster S Soft Caster (+ \$20) <i>Specify for models H4075 and H4077 only</i></p> <p>H .</p>	<p>Select Fabric</p> <p>See page 208</p> <p>C U 1 0 .</p>	<p>Select Frame</p> <p>T Black T1 Platinum Metallic</p> <p>T</p>
--	---	--	---



PAGODA® 4090 Series

H4091



STACKING ARM GUEST CHAIRS

Wood Back
Set of Two

DIMENSIONS

Depth:	22½	Arm Width:	23¾
Width:	27¼	Seat to Floor Height:	18
Height:	32½	Usable Seat Depth:	16¾
Seat Depth:	19¾	Ship Weight:	51
Seat Width:	20¼	Cube:	19.6
Back Width:	21¼	COM (per 2 pack):	1.0
Back Height:	16¼	Weight Rating:	250 lbs.

FABRIC PRICE CODES

	Per Carton List Price	Single Unit List Price
1	\$1101	\$550.50
2	\$1125	\$562.50
3	\$1149	\$574.50
4	\$1167	\$583.50
5	\$1185	\$592.50
6	\$1203	\$601.50
7	\$1221	\$610.50
8	\$1239	\$619.50
9	\$1257	\$628.50
10	\$1275	\$637.50
11	\$1293	\$646.50
12	\$1311	\$655.50
L	—	—

NOTES: Use Model H4069 Ganging Connectors on page 213.

! Ships two per carton. See note on page 212 for ordering.

H4093



STACKING ARMLESS GUEST CHAIRS

Wood Back
Set of Two

DIMENSIONS

Depth:	22½	Seat to Floor Height:	18
Width:	21¼	Usable Seat Depth:	16¾
Height:	32½	Ship Weight:	49
Seat Depth:	19¾	Cube:	18.9
Seat Width:	20¼	COM (per 2 pack):	1.0
Back Width:	20½	Weight Rating:	250 lbs.
Back Height:	16¼		

FABRIC PRICE CODES

	Per Carton List Price	Single Unit List Price
1	\$1038	\$519.00
2	\$1062	\$531.00
3	\$1086	\$543.00
4	\$1104	\$552.00
5	\$1122	\$561.00
6	\$1140	\$570.00
7	\$1158	\$579.00
8	\$1176	\$588.00
9	\$1194	\$597.00
10	\$1212	\$606.00
11	\$1230	\$615.00
12	\$1248	\$624.00
L	—	—

NOTES: Use Model H4069 Ganging Connectors on page 213.

! Ships two per carton. See note on page 212 for ordering.

! Pagoda® wood back models available in Harvest (C), Natural Maple (D), Shaker Cherry (F), Bourbon Cherry (H) and Mahogany (N) only.

HOW TO SPECIFY

<p>Select Model Number</p> <p>H 4 0 9 1 .</p>	<p>Select Finish Color</p> <p>See page 208</p> <p>H .</p>	<p>Select Fabric</p> <p>See page 208</p> <p>C U 1 0 .</p>	<p>Select Frame</p> <p>T Black TI Platinum Metallic</p> <p>T</p>
--	--	--	---

PAGODA® 4090 Series

GSA SIN 33721



Icon Legend on page 15

H4095



STACKING ARM GUEST CHAIRS

Wood Back
Set of Two

DIMENSIONS

Depth:	22½	Arm Width:	23¾
Width:	27¼	Seat to Floor Height:	18
Height:	32½	Usable Seat Depth:	16¾
Seat Depth:	19¾	Ship Weight:	53
Seat Width:	20¼	Cube:	19.6
Back Width:	20½	COM (per 2 pack):	1.0
Back Height:	16¼	Weight Rating:	250 lbs.

FABRIC PRICE CODES

	Per Carton List Price	Single Unit List Price
1	\$1216	\$608.00
2	\$1240	\$620.00
3	\$1264	\$632.00
4	\$1282	\$641.00
5	\$1300	\$650.00
6	\$1318	\$659.00
7	\$1336	\$668.00
8	\$1354	\$677.00
9	\$1372	\$686.00
10	\$1390	\$695.00
11	\$1408	\$704.00
12	\$1426	\$713.00
L	—	—

! Ships two per carton. See note below for ordering.

H4097



MOBILE STACKING ARMLESS GUEST CHAIRS

Wood Back
Set of Two

DIMENSIONS

Depth:	22½	Seat to Floor Height:	18
Width:	21¼	Usable Seat Depth:	16¾
Height:	32½	Ship Weight:	51
Seat Depth:	19¾	Cube:	19.6
Seat Width:	20¼	COM (per 2 pack):	1.0
Back Width:	20½	Weight Rating:	250 lbs.
Back Height:	16¼		

FABRIC PRICE CODES

	Per Carton List Price	Single Unit List Price
1	\$1154	\$577.00
2	\$1178	\$589.00
3	\$1202	\$601.00
4	\$1220	\$610.00
5	\$1238	\$619.00
6	\$1256	\$628.00
7	\$1274	\$637.00
8	\$1292	\$646.00
9	\$1310	\$655.00
10	\$1328	\$664.00
11	\$1346	\$673.00
12	\$1364	\$682.00
L	—	—

! Ships two per carton. See note below for ordering.

- 2 4090 Series is ordered and shipped two (2) chairs per carton. Pricing shown is per carton. Each set of two (one carton), must have the same fabric/frame color. (COM yardage shown is for two chairs.) Ordering 2 of any model will result in 2 cartons being shipped, giving you 4 chairs.
- ! Pagoda® wood back models available in Harvest (C), Natural Maple (D), Shaker Cherry (F), Bourbon Cherry (H) and Mahogany (N) only.

HOW TO SPECIFY

<p>Select Model Number</p> <p>H 4 0 9 5 .</p>	<p>Select Finish Color</p> <p>See page 208</p> <p>H .</p>	<p>Select Fabric</p> <p>See page 208</p> <p>C U 1 0 .</p>	<p>Select Frame</p> <p>T Black T1 Platinum Metallic</p> <p>T</p>
--	--	--	---



PAGODA® 4070/4090 Series

H4099

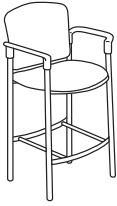

CAFÉ-HEIGHT STOOL

Wood Back
Footrest
Arms

DIMENSIONS

Depth:	22½	Arm Width:	23¾
Width:	27¼	Seat to Floor Height:	29⅝
Height:	44⅝	Usable Seat Depth:	16¾
Seat Depth:	19¾	Ship Weight:	34
Seat Width:	20¼	Cube:	19.3
Back Width:	20½	COM:	1.0
Back Height:	16¼	Weight Rating:	250 lbs.

FABRIC PRICE CODES

Single Unit List Price	
1	\$710.00
2	\$734.00
3	\$758.00
4	\$776.00
5	\$794.00
6	\$812.00
7	\$830.00
8	\$848.00
9	\$866.00
10	\$884.00
11	\$902.00
12	\$920.00
L	—

NOTES: Model H4099 is ordered and shipped one (1) per carton.

H4079

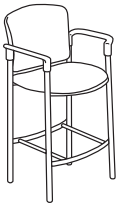

CAFÉ-HEIGHT STOOL

Upholstered Back
Footrest
Arms

DIMENSIONS

Depth:	22½	Arm Width:	23¾
Width:	27¼	Seat to Floor Height:	29⅝
Height:	44⅝	Usable Seat Depth:	16¾
Seat Depth:	19¾	Ship Weight:	39
Seat Width:	20¼	Cube:	19.3
Back Width:	21¼	COM:	1.0
Back Height:	16¼	Weight Rating:	250 lbs.

FABRIC PRICE CODES

Single Unit List Price	
1	\$618.00
2	\$666.00
3	\$714.00
4	\$750.00
5	\$786.00
6	\$822.00
7	\$858.00
8	\$894.00
9	\$930.00
10	\$966.00
11	\$1002.00
12	\$1038.00
L	—

NOTES: Upholstered back. Model H4079 is ordered and shipped one (1) per carton.

H4069



GANGING CONNECTORS

(hardware included)

DIMENSIONS

Ship Weight:	2 Ⓢ
Cube:	0.05

LIST PRICE

\$66.00

NOTES: Specify Chairs frame color: Black (T)
 ⚠ For use on models H4071, H4073, H4091 and H4093.

HOW TO SPECIFY

<p>Select Model Number</p> <p>See page 208</p> <p>Specify for model H4099 only</p>	<p>Select Finish Color</p> <p>See page 208</p> <p>Specify for model H4099 only</p>	<p>Select Fabric</p> <p>See page 208</p>	<p>Select Frame</p> <p>T Black T1 Platinum Metallic</p>
<p>H 4 0 7 9 .</p> <p>H 4 0 9 9 .</p>	<p>H .</p>	<p>C U 1 0 .</p> <p>C U 1 0 .</p>	<p>T</p> <p>T</p>

PARK AVENUE COLLECTION® 5000 SERIES



Park Avenue Executive High-Back Chair shown with 94000 Series™ Desk and Credenza.

PARK AVENUE COLLECTION® 5000 SERIES

Park Avenue seating is your address for elegance. Task chairs feature a choice of Polished Aluminum or Black frame with inlaid wood accents, as well as an elegant tuxedo back design that creates a sophisticated look.



TASK CHAIR FEATURES

- Mid-range knee-tilt mechanism allows for a natural, comfortable recline.
- Pneumatic seat height adjustment moves the seat up and down to adapt to various body heights.
- Tilt tension controls the rate and ease of recline.
- Tilt lock allows the user to lock out the tilt function.
- Arms feature a urethane top pad.
- Base features a steel substrate with hardwood base caps.
- Warranted for users up to 275 lbs.

PARK AVENUE COLLECTION®

5000 Series Options

MODEL OPTIONS

H5001



Executive High-Back

Pneumatic, Swivel, Mid-range
Knee Tilt, Tilt Tension, Tilt Lock,
Open Loop Arms

H5002



Managerial Mid-Back

Pneumatic, Swivel, Mid-range
Knee Tilt, Tilt Tension, Tilt Lock,
Open Loop Arms

AVAILABLE FINISHES

Park Avenue Collection® 5000 Series
Seating is available in 8 wood finishes.

WOOD FINISHES

Bourbon Cherry (H)

Cognac (COGN)

Harvest (C)

Mahogany (N)

Mocha (MOCH)

Natural Maple (D)

Pinnacle (PINC)

Shaker Cherry (F)

HON BRANDED FABRICS

GRADE 1

Centurion
Compass
Contourett Polyurethane
Dapper
Hamilton
Inertia
Optic

GRADE 2

Appoint Seating
Clyde
Dotty
Rush
Seed
Spin Seating
Whisper Vinyl

GRADE 3

Purl
Silvertex™ Vinyl

GRADE L

Denver Leather

For a complete list of fabrics, including partnership fabrics, go to hon.com/fabricsandfinishes.

Reference Fabric Color Combinations on pages 18-22 for color codes and legend on page 19 for lead times. For additional HON to Supply COM fabric grade pricing, go to honready.hon.com and click on the HON to Supply COM link.

⚡ For Fire Code model, availability and ordering method, refer to pages 26-29. Available on select models, contact HON Customer Support for availability.

PARK AVENUE COLLECTION®

5000 Series

GSA SIN 33721



Icon Legend on page 15

H5001



EXECUTIVE HIGH-BACK

Pneumatic
Swivel
Mid-range Knee Tilt
Tilt Tension
Tilt Lock
Open Loop Arms
Functions: **A, E, G, K, L**
(Function Key on pages 16-17)

DIMENSIONS

Depth:	29	Arm Width:	20
Width:	26	Seat to Floor Height:	17 ³ / ₄ -22 ¹ / ₂
Height:	44 ¹ / ₂	Usable Seat Depth:	17 ⁵ / ₈
Seat Depth:	19 ¹ / ₂	Ship Weight:	61
Seat Width:	20	Cube:	23.7
Back Width:	20	COM:	3.0
Back Height:	26 ¹ / ₄	Weight Rating:	250 lbs.

FABRIC PRICE CODES

1	\$1079	8	\$1493
2	\$1151	9	\$1547
3	\$1223	10	\$1601
4	\$1277	11	\$1655
5	\$1331	12	\$1709
6	\$1385	L	\$1679
7	\$1439		

NOTES: Arms are selected hardwood with urethane top pads.

H5002



MANAGERIAL MID-BACK

Pneumatic
Swivel
Mid-range Knee Tilt
Tilt Tension
Tilt Lock
Open Loop Arms
Functions: **A, E, G, K, L**
(Function Key on pages 16-17)

DIMENSIONS

Depth:	29	Arm Width:	20
Width:	26	Seat to Floor Height:	17 ³ / ₄ -22 ¹ / ₂
Height:	39 ¹ / ₂	Usable Seat Depth:	17 ⁵ / ₈
Seat Depth:	19 ¹ / ₂	Ship Weight:	57
Seat Width:	20	Cube:	18.5
Back Width:	20	COM:	2.5
Back Height:	19 ¹ / ₄	Weight Rating:	250 lbs.

FABRIC PRICE CODES

1	\$1051	8	\$1396
2	\$1111	9	\$1441
3	\$1171	10	\$1486
4	\$1216	11	\$1531
5	\$1261	12	\$1576
6	\$1306	L	\$1551
7	\$1351		

NOTES: Arms are selected hardwood with urethane top pads.

HON Recommendation: H5001.MOCH.CU__ - List Price \$1079

HOW TO SPECIFY

Select
Model Number

H5001

Select
Finish

See page 215

MOCH

Select
Fabric

See page 215

CU10

PARK AVENUE COLLECTION® 5020 SERIES



Park Avenue Mid-Back Chairs shown with Preside® Conference Table.

PARK AVENUE COLLECTION® 5020 SERIES

Park Avenue seating is your address for elegance. This family of task and guest seating features all-day comfort with upscale accents. Task chairs feature a Polished Aluminum base, as well as an elegant tuxedo back design that creates a sophisticated look. Guest seating welcomes visitors in style and leaves a lasting impression. If you're looking to put yourself, your coworkers and your visitors at ease, make a move to Park Avenue.



GUEST CHAIR FEATURES

- Fully-upholstered outer back.
- Backs feature sewn seams for a tailored look.
- Black powder coated frame.
- Warranted for users up to 275 lbs.

TASK CHAIR FEATURES

- Mid-range knee-tilt mechanism allows for a natural, comfortable recline.
- Pneumatic seat height adjustment moves the seat up and down to adapt to various body heights.
- Tilt tension controls the rate and ease of recline.
- Tilt lock allows the user to lock out the tilt function.
- Arms feature a urethane top pad.
- Polished Aluminum base.
- Warranted for users up to 275 lbs.

PARK AVENUE COLLECTION®

5020 Series Options

MODEL OPTIONS

H5021



Executive High-Back

Pneumatic, Swivel, Mid-range Knee Tilt, Tilt Tension, Tilt Lock, Open Loop Arms

H5022



Managerial Mid-Back

Pneumatic, Swivel, Mid-range Knee Tilt, Tilt Tension, Tilt Lock, Open Loop Arms

H5023



Guest Chair

Sled Base, Arms

CASTERS



CODE	DESCRIPTION	PRICE
H	Hard Caster	+\$0



S	Soft Caster	+\$30
---	-------------	--------------

*Specify for models H5021 and H5022 only

HON BRANDED FABRICS

GRADE 1

Attire
Centurion
Compass
Contourett Polyurethane
Dapper
Hamilton
Inertia
Optic

GRADE 2

Appoint Seating
Clyde
Dotty
Rush
Seed
Spin Seating
Whisper Vinyl

GRADE 3

Purl
Silvertex™ Vinyl

GRADE L

Denver Leather

For a complete list of fabrics, including partnership fabrics, go to hon.com/fabricsandfinishes.

Reference Fabric Color Combinations on pages 18-22 for color codes and legend on page 19 for lead times. For additional HON to Supply COM fabric grade pricing, go to honready.hon.com and click on the HON to Supply COM link.

For Fire Code model, availability and ordering method, refer to pages 26-29. Available on select models, contact HON Customer Support for availability.



PARK AVENUE COLLECTION®

5020 Series

H5021



EXECUTIVE HIGH-BACK

Pneumatic
Swivel
Mid-range Knee Tilt
Tilt Tension
Tilt Lock
Open Loop Arms
Functions: **A, E, G, K, L**
(Function Key on pages 16-17)

DIMENSIONS

Depth: 29
Width: 26
Height: 44½
Seat Depth: 17⅝
Seat Width: 20
Back Width: 20
Back Height: 26¼
Arm Width: 20
Seat to Floor Height: 17¾-22½
Usable Seat Depth: 17⅝
Ship Weight: 57
Cube: 16.0
COM: 3.0
Weight Rating: 250 lbs.

FABRIC PRICE CODES

1	\$1166	8	\$1580
2	\$1238	9	\$1634
3	\$1310	10	\$1688
4	\$1364	11	\$1742
5	\$1418	12	\$1796
6	\$1472	L	\$1766
7	\$1526		

Polished aluminum base

H5022



MANAGERIAL MID-BACK

Pneumatic
Swivel
Mid-range Knee Tilt
Tilt Tension
Tilt Lock
Open Loop Arms
Functions: **A, E, G, K, L**
(Function Key on pages 16-17)

DIMENSIONS

Depth: 29
Width: 26
Height: 38½
Seat Depth: 17⅝
Seat Width: 20
Back Width: 20
Back Height: 19¼
Arm Width: 20
Seat to Floor Height: 17¾-22½
Usable Seat Depth: 17⅝
Ship Weight: 54
Cube: 16.0
COM: 2.5
Weight Rating: 250 lbs.

FABRIC PRICE CODES

1	\$1139	8	\$1484
2	\$1199	9	\$1529
3	\$1259	10	\$1574
4	\$1304	11	\$1619
5	\$1349	12	\$1664
6	\$1394	L	\$1639
7	\$1439		

Polished aluminum base

H5023



GUEST CHAIR

Sled Base
Arms

DIMENSIONS

Depth: 27
Width: 25
Height: 35½
Seat Depth: 17⅝
Seat Width: 20
Back Width: 20
Back Height: 19¼
Arm Width: 20
Seat to Floor Height: 18½
Usable Seat Depth: 17⅝
Ship Weight: 45
Cube: 18.4
COM: 2.5
Weight Rating: 250 lbs.

FABRIC PRICE CODES

1	\$881	8	\$1226
2	\$941	9	\$1271
3	\$1001	10	\$1316
4	\$1046	11	\$1361
5	\$1091	12	\$1406
6	\$1136	L	\$1381
7	\$1181		

Black powder coated frame

HON Recommendation: H5021.H.CU__ - List Price \$1166

HOW TO SPECIFY

Select Model Number

H5021

Select Caster

H Hard Caster
S Soft Caster (+ \$30)
Specify for models H5021 and H5022 only

H

Select Fabric

See page 218

CU10

PERCH™ Active Seating

OPEN MARKET



Icon Legend on page 15

HVLPERCH



PERCH STOOL

Pneumatic
Swivel
Pivot Base

DIMENSIONS

Depth:	16½	Seat to Floor Height:	23¾-35
Width:	15¾	Usable Seat Depth:	14½
Seat Depth:	14½	Ship Weight:	22 Ⓢ
Seat Width:	14½	Cube:	3.13
		Weight Rating:	250 lbs.

PRICE CODE

Fabric **\$507**

NOTES: Fabric seat in Black and Charcoal. Built-in handle. Active pivot base. Silver frame. **HON 5-Year Limited Warranty.**

HON Recommendation: HVLPERCH.ASF10.X - List Price \$507

HVL991

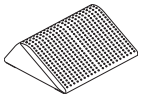

FOOTREST

Anti-Slip Cover

DIMENSIONS

Depth:	13¾	Ship Weight:	7 Ⓢ
Width:	16	Cube:	0.9
Height:	5½	Weight Rating:	250 lbs.

LIST PRICE

\$82

! Available in Black (T) finish ONLY. **HON 5-Year Limited Warranty.**

SPECIFYING EXAMPLE: HVL991.T

HBEAFM1

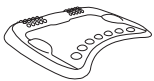

ANTI-FATIGUE MAT

Ergonomic

DIMENSIONS

Depth:	25	Ship Weight:	7
Width:	29⅞	Cube:	1.4
Height:	2¾		

LIST PRICE

\$219

! Available in Black ONLY. No specification needed. **HON 5-Year Limited Warranty.**

SPECIFYING EXAMPLE: HBEAFM1

HOW TO SPECIFY

<p>Select Model Number</p> <p>H V L P E R C H .</p>	<p>Select Fabric</p> <p>ASF10 Black Fabric ASF19 Charcoal Fabric</p> <p>A S F 1 0 .</p>	<p>Select Frame</p> <p>X Silver</p> <p>X</p>
--	--	---

PERPETUAL® NESTING CHAIRS



PERPETUAL® NESTING CHAIRS

Always attractive, always supportive — that's Perpetual. Provide full-time comfort to even part-time workers with the Perpetual line of multi-purpose seating. The flip-up seat design maximizes space by allowing Perpetual to be easily nested. The passive back design moves with the user to deliver added comfort for all day meetings. Save space without sacrificing comfort with Perpetual.



FEATURES

- Flip-up seat allows chairs to nest and save floor space.
- Backrest reclines for added comfort.
- Tube rolled steel frame adds durability.
- Underside of seat is fully-upholstered for a clean appearance when nested.
- All-surface casters roll effortlessly and silently.
- Available in hundreds of quality HON fabrics.
- Warranted for users up to 300 lbs.

PERPETUAL® Nesting Chairs Options

MODEL OPTIONS

HPN1



Nesting Chair (Flex-back)

Armless, Four Legs

HPN2



Nesting Chair (Flex-back)

Fixed Arms, Four Legs

CASTER/ GLIDE



CODE	DESCRIPTION	PRICE
A	All-surface	+\$0
G	Bell Glide	+\$25

FRAME

CODE	DESCRIPTION	PRICE
T	Black	+\$0
T1	Platinum Metallic	+\$0

BACK STYLE



CODE	DESCRIPTION	PRICE
UU	Upholstered Back	+\$0

HON BRANDED FABRICS

GRADE 1

Attire
Centurion
Compass
Contourett Polyurethane
Dapper
Hamilton
Inertia
Optic

GRADE 2

Appoint Seating
Clyde
Dotty
Rush
Seed
Spin Seating
Whisper Vinyl

GRADE 3

Purl
Silvertext™ Vinyl

For a complete list of fabrics, including partnership fabrics, go to hon.com/fabricsandfinishes.

Reference Fabric Color Combinations on pages 18-22 for color codes and legend on page 19 for lead times. For additional HON to Supply COM fabric grade pricing, go to honready.hon.com and click on the HON to Supply COM link.

For Fire Code model, availability and ordering method, refer to pages 26-29. Available on select models, contact HON Customer Support for availability.



PERPETUAL[®] Nesting Chairs

HPN1



Model HPN1AUU shown

NESTING CHAIR

Flex-back
Armless
Four Legs

DIMENSIONS

Depth:	26	Seat to Floor Height:	19 $\frac{1}{8}$
Width:	26	Usable Seat Depth:	16 $\frac{1}{2}$
Height:	36	Ship Weight:	38
Seat Depth:	17 $\frac{3}{4}$	Cube:	15.2
Seat Width:	17	COM:	1.5
Back Width:	17 $\frac{1}{2}$	Weight Rating:	300 lbs.
Back Height:	15 $\frac{3}{4}$		

FABRIC PRICE CODES

1	\$673	8	\$880
2	\$709	9	\$907
3	\$745	10	\$934
4	\$772	11	\$961
5	\$799	12	\$988
6	\$826	L	—
7	\$853		

HPN2



Model HPN2AUU shown

NESTING CHAIR

Flex-back
Fixed Arms
Four Legs

DIMENSIONS

Depth:	26	Arm Width:	20 $\frac{3}{4}$
Width:	26	Seat to Floor Height:	19 $\frac{1}{8}$
Height:	36	Usable Seat Depth:	16 $\frac{1}{2}$
Seat Depth:	17 $\frac{3}{4}$	Ship Weight:	41
Seat Width:	17	Cube:	15.2
Back Width:	17 $\frac{1}{2}$	COM:	1.5
Back Height:	15 $\frac{3}{4}$	Weight Rating:	300 lbs.

FABRIC PRICE CODES

1	\$745	8	\$952
2	\$781	9	\$979
3	\$817	10	\$1006
4	\$844	11	\$1033
5	\$871	12	\$1060
6	\$898	L	—
7	\$925		

HOW TO SPECIFY

<p>Select Model Number</p> <p>HPN1</p>	<p>Select Caster/Glide</p> <p>A All-surface G Glide (+ \$25)</p> <p>A</p>	<p>Select Back Type</p> <p>UU Upholstered Back</p> <p>UU</p>	<p>Select Fabric</p> <p>Note: For models with upholstered back, seat and back are always matching fabric See page 222</p> <p>CU10</p>	<p>Select Frame</p> <p>T Black T1 Platinum Metallic</p> <p>T</p>
---	--	---	--	---

PILLOW-SOFT® 2090 SERIES



Pillow-Soft High-Back Executive and Sled Base Guest Chairs shown with 10700 Series™ desks.

PILLOW-SOFT® 2090 SERIES

Pillow-Soft chairs combine comfort, style and selection to deliver the ultimate seating experience. Each executive chair in the collection combines thick memory foam cushioning with built-in lumbar support to reduce fatigue and increase comfort. Besides the full body support, it adds an authoritative presence to the office. The plush tufted leather or fabric will add a touch of sophistication to your office.



FEATURES

- Responsive memory foam eliminates pressure points and provides lasting comfort.
- Loop arms relieve stress on the shoulder and neck.
- Fully-upholstered outer back.
- Memory foam seat cushion reduces pressure points and responds to contours of the body for lasting comfort.
- Task chairs come standard with pneumatic seat height adjustment, tilt, tilt tension and tilt lock.
- Dual-wheel casters roll effortlessly and silently.
- Warranted for users up to 300 lbs.

PILLOW-SOFT® 2090 Series Options

MODEL OPTIONS

H2091



Executive High-Back

Pneumatic, Swivel, Tilt, Tilt Tension, Tilt Lock, Arms

H2095



Executive High-Back

Pneumatic, Swivel, Tilt, Tilt Tension, Tilt Lock, Arms

H2092



Managerial Mid-Back

Pneumatic, Swivel, Tilt, Tilt Tension, Tilt Lock, Arms

H2093



Guest Chair

Sled Base, Arms

CASTERS



CODE	DESCRIPTION	PRICE
H	Hard Caster	+ \$0



S	Soft Caster	+ \$30
----------	-------------	---------------

HON BRANDED FABRICS

GRADE 1

Black Vinyl
Burgundy Vinyl
Centurion
Compass
Contourett Polyurethane
Dapper
Hamilton
Inertia
Optic

GRADE 2

Appoint Seating
Clyde
Dotty
Rush
Seed
Spin Seating
Whisper Vinyl

GRADE 3

Purl
Silvertex™ Vinyl

For a complete list of fabrics, including partnership fabrics, go to hon.com/fabricsandfinishes.

Reference Fabric Color Combinations on pages 18-22 for color codes and legend on page 19 for lead times. For additional HON to Supply COM fabric grade pricing, go to honready.hon.com and click on the HON to Supply COM link.

 For Fire Code model, availability and ordering method, refer to pages 26-29. Available on select models, contact HON Customer Support for availability.

PILLOW-SOFT® 2090 Series

GSA SIN 33721 EXCEPT AS NOTED



Icon Legend on page 15

H2091



EXECUTIVE HIGH-BACK

Pneumatic
Swivel
Tilt
Tilt Tension
Tilt Lock
Arms
Functions: **A, E, F, K, L**
(Function Key on pages 16-17)

DIMENSIONS

Depth: 29¾
Width: 26¼
Height: 46½
Seat Depth: 21
Seat Width: 22
Back Width: 22
Back Height: 25
Arm Width: 20¼
Seat to Floor Height: 16¾-21¼
Usable Seat Depth: 18½
Ship Weight: 57
Cube: 16.0
COM: 3.0
Weight Rating: 300 lbs.

FABRIC PRICE CODES

1	\$652	8	\$1066
2	\$724	9	\$1120
3	\$796	10	\$1174
4	\$850	11	\$1228
5	\$904	12	\$1282
6	\$958	L	\$802
7	\$1012		

NOTES: When selecting leather, the 2090 Series uses SR Leather only. All models are also available in Grade 1 EB vinyl (which matches SR Leather).

H2095



OPEN MARKET

EXECUTIVE HIGH-BACK

Pneumatic
Swivel
Tilt
Tilt Tension
Tilt Lock
Padded Loop Arms
Functions: **A, E, F, K, L**
(Function Key on pages 16-17)

DIMENSIONS

Depth: 29½
Width: 26¾
Height: 47½
Seat Depth: 17½
Seat Width: 21
Back Width: 21
Back Height: 29½
Arm Width: 21
Seat to Floor Height: 16-21
Usable Seat Depth: 17½
Ship Weight: 57
Cube: 7.1
COM: N/A
Weight Rating: 275 lbs.

FABRIC PRICE CODES

Fabric			
PWST10	\$514	(Black)	
SofThread™ Leather			
PWST11	\$534	(Black)	

NOTES: When selecting upholstery, the H2095 is only available in PWST10 (Black fabric) and PWST11 (Black SofThread™ Leather).

H2092



MANAGERIAL MID-BACK

Pneumatic
Swivel
Tilt
Tilt Tension
Tilt Lock
Arms
Functions: **A, E, F, K, L**
(Function Key on pages 16-17)

DIMENSIONS

Depth: 28¾
Width: 26¼
Height: 41¾
Seat Depth: 21
Seat Width: 22
Back Width: 22
Back Height: 19¾
Arm Width: 20¼
Seat to Floor Height: 16¾-21¼
Usable Seat Depth: 18½
Ship Weight: 54
Cube: 16.0
COM: 3.0
Weight Rating: 300 lbs.

FABRIC PRICE CODES

1	\$623	8	\$1037
2	\$695	9	\$1091
3	\$767	10	\$1145
4	\$821	11	\$1199
5	\$875	12	\$1253
6	\$929	L	\$773
7	\$983		

NOTES: When selecting leather, the 2090 Series uses SR Leather only. All models are also available in Grade 1 EB vinyl (which matches SR Leather).

H2093



GUEST CHAIR

Sled Base
Arms

DIMENSIONS

Depth: 27¾
Width: 23¼
Height: 36
Seat Depth: 21½
Seat Width: 20¾
Back Width: 21½
Back Height: 19¼
Arm Width: 19¾
Seat to Floor Height: 19½
Usable Seat Depth: 19
Ship Weight: 38
Cube: 16.1
COM: 2.5
Weight Rating: 300 lbs.

FABRIC PRICE CODES

1	\$498	8	\$843
2	\$558	9	\$888
3	\$618	10	\$933
4	\$663	11	\$978
5	\$708	12	\$1023
6	\$753	L	\$648
7	\$798		

NOTES: When selecting leather, the 2090 Series uses SR Leather only. All models are also available in Grade 1 EB vinyl (which matches SR Leather).

HOW TO SPECIFY

HON Recommendation: H2091.H.SR11.T - List Price \$802

<p>Select Model Number</p> <p>H 2 0 9 1 .</p>	<p>Select Caster</p> <p>H Hard Caster S Soft Caster (+ \$30) <i>Does not apply to models H2093 or H2095</i></p> <p>H .</p>	<p>Select Fabric</p> <p>See page 225 <i>H2095 only available in 2 fabric options. See above for pricing and selection.</i></p> <p>S R 1 1 .</p>	<p>Select Frame</p> <p>T Black</p> <p>T</p>
--	---	--	--

PILLOW-SOFT® 2190 SERIES



Pillow-Soft Executive High-Back and Guest Chairs shown with Park Avenue Collection® Laminate desks.

PILLOW-SOFT® 2190 SERIES

Pillow-Soft chairs combine comfort, style and selection to deliver the ultimate seating experience. Each executive chair in the collection combines thick memory foam cushioning with built-in lumbar support to reduce fatigue and increase comfort. Besides the full body support, it adds an authoritative presence to the office. The plush tufted leather or fabric and optional hardwood accents will add a touch of sophistication to your office.



FEATURES

- Responsive memory foam eliminates pressure points and provides lasting comfort.
- Loop arms relieve stress on the shoulder and neck.
- Fully-upholstered outer back.
- Base features a steel substrate with hardwood base caps.
- Memory foam seat cushion reduces pressure points and responds to contours of the body for lasting comfort.
- Dual-wheel casters roll effortlessly and silently.
- Solid hardwood in one of eight attractive finishes.
- Warranted for users up to 275 lbs.

PILLOW-SOFT® 2190 Series Options

MODEL OPTIONS

H2191



Executive High-Back

Pneumatic, Swivel, Tilt, Tilt Tension, Tilt Lock, Open Padded Loop Arms

H2192



Managerial Mid-Back

Pneumatic, Swivel, Tilt, Tilt Tension, Tilt Lock, Open Padded Loop Arms

H2194



Guest Chair

4-Leg Base, Open Loop Arms

AVAILABLE FINISHES

Pillow-Soft® 2190 Series Seating is available in 8 wood finishes.

WOOD FINISHES

Bourbon Cherry (H)

Cognac (COGN)

Harvest (C)

Mahogany (N)

Mocha (MOCH)

Natural Maple (D)

Pinnacle (PINC)

Shaker Cherry (F)

HON BRANDED FABRICS

GRADE 1

Black Vinyl
Burgundy Vinyl
Centurion
Compass
Contourett Polyurethane
Dapper
Hamilton
Inertia
Optic

GRADE 2

Appoint Seating
Clyde
Dotty
Rush
Seed
Spin Seating
Whisper Vinyl

GRADE 3

Purl
Silvertex™ Vinyl

For a complete list of fabrics, including partnership fabrics, go to hon.com/fabricsandfinishes.

Reference Fabric Color Combinations on pages 18-22 for color codes and legend on page 19 for lead times. For additional HON to Supply COM fabric grade pricing, go to honready.hon.com and click on the HON to Supply COM link.

 For Fire Code model, availability and ordering method, refer to pages 26-29. Available on select models, contact HON Customer Support for availability.



Icon Legend on page 15

PILLOW-SOFT® 2190 Series

H2191



EXECUTIVE HIGH-BACK

Pneumatic
Swivel
Tilt
Tilt Tension
Tilt Lock
Open Padded Loop Arms
Functions: **A, E, F, K, L**
(Function Key on pages 16-17)

DIMENSIONS

Depth: 29¾
Width: 26¼
Height: 46½
Seat Depth: 21
Seat Width: 22
Back Width: 22
Back Height: 25
Arm Width: 22¼
Seat to Floor Height: 16¾-21¼
Usable Seat Depth: 18½
Ship Weight: 60
Cube: 16.0
COM: 3.0
Weight Rating: 250 lbs.

FABRIC PRICE CODES

1	\$1024	8	\$1438
2	\$1096	9	\$1492
3	\$1168	10	\$1546
4	\$1222	11	\$1600
5	\$1276	12	\$1654
6	\$1330	L	\$1174
7	\$1384		

NOTES: Arms are laminated hardwood with urethane top pads. Also available in Grade 1 vinyl EB11 and EB69. (EB matching vinyl used with SR Leather).

H2192



MANAGERIAL MID-BACK

Pneumatic
Swivel
Tilt
Tilt Tension
Tilt Lock
Open Padded Loop Arms
Functions: **A, E, F, K, L**
(Function Key on pages 16-17)

DIMENSIONS

Depth: 28¾
Width: 26¼
Height: 41¾
Seat Depth: 21
Seat Width: 22
Back Width: 22
Back Height: 19⅝
Arm Width: 22¼
Seat to Floor Height: 16¾-21¼
Usable Seat Depth: 18½
Ship Weight: 57
Cube: 16.0
COM: 2.5
Weight Rating: 250 lbs.

FABRIC PRICE CODES

1	\$995	8	\$1340
2	\$1055	9	\$1385
3	\$1115	10	\$1430
4	\$1160	11	\$1475
5	\$1205	12	\$1520
6	\$1250	L	\$1145
7	\$1295		

NOTES: Arms are laminated hardwood with urethane top pads. Also available in Grade 1 vinyl EB11 and EB69. (EB matching vinyl used with SR Leather).

H2194



GUEST CHAIR

4-Leg Base
Open Loop Arms

DIMENSIONS

Depth: 27½
Width: 23¼
Height: 35½
Seat Depth: 21½
Seat Width: 20¾
Back Width: 21½
Back Height: 19¼
Arm Width: 19¾
Seat to Floor Height: 19½
Usable Seat Depth: 19
Ship Weight: 49
Cube: 17.3
COM: 2.5
Weight Rating: 250 lbs.

FABRIC PRICE CODES

1	\$809	8	\$1154
2	\$869	9	\$1199
3	\$929	10	\$1244
4	\$974	11	\$1289
5	\$1019	12	\$1334
6	\$1064	L	\$959
7	\$1109		

NOTES: Guest Chairs available in 4-Leg Base. Also available in Grade 1 vinyl EB11 and EB69. (EB matching vinyl used with SR Leather).

HON Recommendation: H2191.MOCH.CU__ - List Price \$1024

HOW TO SPECIFY

Select Model Number

H 2 1 9 1

Select Finish

See page 228

M O C H

Select Fabric

See page 228

C U 1 0

PROMINENT™ Mesh Chairs

OPEN MARKET



Icon Legend on page 15

HVL531



HIGH-BACK

Pneumatic
Swivel
Tilt
Tilt Tension
Tilt Lock
Height-adjustable Arms

Functions: **A, E, F, K, L, Q**
(Function Key on pages 16-17)

DIMENSIONS

Depth:	27	Arm Width:	20¼
Width:	27	Seat to Floor Height:	18-22
Height:	42½	Usable Seat Depth:	18
Seat Depth:	18	Ship Weight:	36 Ⓢ
Seat Width:	21½	Cube:	5.1
Back Width:	18¾	Weight Rating:	250 lbs.
Back Height:	23		

PRICE CODE

Sandwich Mesh **\$399**
Leather **\$424**

NOTES: Comfortable and breathable mesh back. Black Sandwich Mesh or Black SofThread™ Leather seat. Black frame. Height-adjustable arms. **HON 5-Year Limited Warranty.**

HON Recommendation: HVL531.MM10 - List Price \$399

HVL530



HIGH-BACK

Synchro-tilt with Seat Slide
Back Height Adjustment
Height and Width Adjustable Arms

Functions: **A, B, D, E, J, S**
(Function Key on pages 16-17)

DIMENSIONS

Depth:	26¾	Back Height:	22¼
Width:	26	Arm Width:	18¾
Height:	44¼	Seat to Floor Height:	17¼-21
Seat Depth:	17½	Ship Weight:	46
Seat Width:	20¾	Cube:	5.0
Back Width:	17⅞	Weight Rating:	250 lbs.

PRICE CODE

Sandwich Mesh **\$432**

NOTES: **HON 5-Year Limited Warranty.**

HON Recommendation: HVL530.MM10 - List Price \$432

HVL532



HIGH-BACK

Mesh Back
Pneumatic
Swivel
Asynchronous Control
Tilt
Tilt Tension
Tilt Lock
Seat Glide Mechanism
Back Height Adjustment
Height and Width Adjustable Arms

Functions: **A, B, D, E, F, L, O, S**
(Function Key on pages 16-17)

DIMENSIONS

Depth:	26	Back Height:	23¼-24½
Width:	30¾	Arm Width:	18-22⅝
Height:	44½	Seat to Floor Height:	17-20½
Seat Depth:	17⅞-20⅞	Ship Weight:	50 Ⓢ
Seat Width:	20½	Cube:	6.5
Back Width:	19⅞	Weight Rating:	250 lbs.

PRICE CODE

Sandwich Mesh **\$475**
Leather **\$500**

NOTES: Comfortable and breathable mesh back. Black Sandwich Mesh or Black SofThread™ Leather seat. Black frame. Height and width adjustable arms. Seat glide mechanism. Asynchronous control with independent seat and back angle adjustment. **HON 5-Year Limited Warranty.**

HON Recommendation: HVL532.MM10 - List Price \$475

HOW TO SPECIFY

<p>Select Model Number</p>	<p>Select Fabric</p> <p>MM10 Black Sandwich Mesh Fabric <i>HVL530 available in MM10 only</i></p> <p>SB11 Black SofThread™ Leather</p>
<p>H V L 5 3 1 .</p>	<p>M M 1 0</p>



PROMINENT™ Mesh Chairs

HVL534



HIGH-BACK

Pneumatic
Swivel
Tilt
Tilt Tension
Tilt Lock
Height-adjustable Arms

Functions: **A, E, F, K, L, Q**
(Function Key on pages 16-17)

DIMENSIONS

Depth:	27	Arm Width:	19 ⁵ / ₈
Width:	27	Seat to Floor Height:	17 ¹ / ₈ -20 ³ / ₄
Height:	41 ¹ / ₈	Usable Seat Depth:	19 ¹ / ₈
Seat Depth:	19 ¹ / ₈	Ship Weight:	40.6 Ⓢ
Seat Width:	20 ¹ / ₈	Cube:	5.7
Back Width:	19 ¹ / ₈	Weight Rating:	250 lbs.
Back Height:	22 ³ / ₈		

PRICE CODE

Mesh \$490

NOTES: Prominent™ HVL534. Comfortable and breathable mesh back. Black Mesh seat. Height-adjustable arms. **HON 5-Year Limited Warranty.**

HON Recommendation: HVL534.MST3 - List Price \$490

HVL537



HIGH-BACK

Mesh Back
Synchro-tilt with Seat Slide
Back Height Adjustment
Height and Width Adjustable
Arms
Mesh Seat

Functions: **A, B, D, E, J, S**
(Function Key on pages 16-17)

DIMENSIONS

Depth:	26 ¹ / ₂	Arm Width:	18 ³ / ₄
Width:	26 ¹ / ₂	Seat to Floor Height:	17 ³ / ₄ -21
Height:	44 ³ / ₄	Usable Seat Depth:	17 ³ / ₄
Seat Depth:	17 ³ / ₄	Ship Weight:	46.0
Seat Width:	20 ³ / ₄	Cube:	5.0
Back Width:	17 ¹ / ₈	Weight Rating:	250 lbs.
Back Height:	22 ¹ / ₄		

PRICE CODE

Mesh \$523

NOTES: **HON 5-Year Limited Warranty.**

HON Recommendation: HVL537.MST3 - List Price \$523

HVL536



HIGH-BACK

Mesh Back
Asynchronous with Seat Slide
Back Height Adjustment
Height and Width Adjustable
Arms
Mesh Seat

Functions: **A, B, D, E, F, L, O, S**
(Function Key on pages 16-17)

DIMENSIONS

Depth:	26 ¹ / ₂	Arm Width:	18 ⁷ / ₈
Width:	26 ¹ / ₂	Seat to Floor Height:	16 ³ / ₈ -20 ³ / ₈
Height:	44 ³ / ₄	Usable Seat Depth:	17 ¹ / ₈
Seat Depth:	17 ³ / ₄	Ship Weight:	48.7
Seat Width:	20 ¹ / ₂	Cube:	6.3
Back Width:	17 ¹ / ₈	Weight Rating:	250 lbs.
Back Height:	22 ³ / ₈		

PRICE CODE

Mesh \$555

NOTES: **HON 5-Year Limited Warranty.**

HON Recommendation: HVL536.MST3 - List Price \$555

HVL539



TASK STOOL

Mesh Back
Pneumatic
Swivel
Height and Width Adjustable
Arms
Adjustable Footring

Functions: **A, E, S**
(Function Key on pages 16-17)

DIMENSIONS

Depth:	27 ⁹ / ₁₆	Arm Width:	18 ¹ / ₈
Width:	28 ¹ / ₃₂	Seat to Floor Height:	21 ⁹ / ₃₂ -28 ⁵ / ₃₂
Height:	50	Usable Seat Depth:	17 ¹ / ₈
Seat Depth:	17 ¹ / ₈	Ship Weight:	44.0 Ⓢ
Seat Width:	20 ¹⁵ / ₃₂	Cube:	5.7
Back Width:	17 ¹ / ₈	Weight Rating:	250 lbs.
Back Height:	22 ²⁷ / ₃₂		

PRICE CODE

Sandwich Mesh \$431

NOTES: Prominent™ HVL539. Black upholstered seat. Height and width adjustable arms. **HON 5-Year Limited Warranty.**

HON Recommendation: HVL539.MM10 - List Price \$431

HOW TO SPECIFY

<p>Select Model Number</p>	<p>Select Fabric</p> <p>MM10 Black Sandwich Mesh Fabric <i>Specify for model HVL539 only</i></p> <p>MST3 Black Mesh <i>Specify for models HVL534, HVL536 and HVL537 only</i></p>
<p>H V L 5 3 4 .</p>	<p>M S T 3</p>

QUOTIENT®



Quotient Task Chairs shown with Voi® Desks.

QUOTIENT®

Finding a universal seating solution to satisfy a variety of needs and users can be challenging, especially with something as personal as a chair. With a mesh back for comfort, an advanced seat cushion that follows the body's contours, and a stool option for standing-height worksurfaces, Quotient is much more than the sum of its parts. Height- and width-adjustable arms help anyone find the upper body support they need. The perfect blend of comfort and style, Quotient is where form and function are perfectly divided.



FEATURES

- Contoured seat cushion reduces pressure points.
- Responsive synchro-tilt control provides a smooth, natural recline.
- 4-Way Stretch mesh cradles the spine.
- One-touch seat height adjustment easily moves the seat up and down.
- Tilt tension controls the rate and ease of recline.
- Tilt lock allows the user to lock out the tilt function.
- 360-degree swivel provides freedom of movement in any direction.
- Height- and width-adjustable arms provide a custom fit.
- Available in hundreds of quality HON fabrics.
- Warranted for users up to 300 lbs.

MODEL OPTIONS

HQTMM



Task Chair

Pneumatic, Swivel, Synchro-tilt, Tilt Tension, Tilt Lock

HQTSM



Task Stool

Pneumatic, Swivel, Synchro-tilt, Tilt Tension, Tilt Lock

MECHANISM



CODE	DESCRIPTION	PRICE
YO	Synchro-Tilt	+\$0

ARM STYLE



CODE	DESCRIPTION	PRICE
N	Armless	+\$0
A	Height and Width Adjustable Arms	+\$75

CASTERS/ GLIDE



CODE	DESCRIPTION	PRICE
H	Hard Caster	+\$0



S	Soft Caster	+\$30
----------	-------------	--------------



G	Bell Glide	+\$25
----------	------------	--------------

BACK



CODE	DESCRIPTION	PRICE
<i>4-Way Stretch mesh back options:</i>		
IM	Black	+\$0

BASE



CODE	DESCRIPTION	PRICE
SB	Standard Base	+\$0

QUOTIENT® Fabric Options

HON BRANDED FABRICS

GRADE 1

Attire
Centurion
Compass
Contourett Polyurethane
Dapper
Hamilton
Inertia
Optic

GRADE 2

Appoint Seating
Clyde
Dotty
Rush
Seed
Spin Seating
Whisper Vinyl

GRADE 3

In Season
Purl
Silvertex™ Vinyl

For a complete list of fabrics, including partnership fabrics, go to hon.com/fabricsandfinishes.

Reference Fabric Color Combinations on pages 18-22 for color codes and legend on page 19 for lead times.

 For Fire Code model, availability and ordering method, refer to pages 26-29. Available on select models, contact HON Customer Support for availability.



Icon Legend on page 15

HQTMM

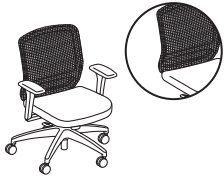

TASK CHAIR

Pneumatic
Swivel
Synchro-tilt
Tilt Tension
Tilt Lock
Functions: **A, E, J, K, L**
(Function Key on pages 16-17)

DIMENSIONS

Depth:	29½	Arm Width:	17½-20
Width:	29½	Seat to Floor Height:	16-22
Height:	38½	Usable Seat Depth:	17
Seat Depth:	19¼	Ship Weight (with arms):	36.5 Ⓢ
Seat Width:	19	Ship Weight (armless):	33.0 Ⓢ
Back Width:	18	Cube (with arms):	7.6
Back Height:	19	Cube (armless):	7.6
		Weight Rating:	300 lbs.

FABRIC PRICE CODES

1	\$493	8	\$562
2	\$505	9	\$571
3	\$517	10	\$580
4	\$526	11	\$589
5	\$535	12	\$598
6	\$544	L	—
7	\$553		

HQTSM



TASK STOOL

Pneumatic
Swivel
Synchro-tilt
Tilt Tension
Tilt Lock
Functions: **A, E, J, K, L**
(Function Key on pages 16-17)

DIMENSIONS

Depth:	29½	Arm Width:	17½-20
Width:	29½	Seat to Floor Height:	23-33
Height:	49¼	Usable Seat Depth:	17
Seat Depth:	19¼	Ship Weight (with arms):	42.0 Ⓢ
Seat Width:	19	Ship Weight (armless):	38.5 Ⓢ
Back Width:	18	Cube (with arms):	7.6
Back Height:	19	Cube (armless):	7.6
		Weight Rating:	300 lbs.

FABRIC PRICE CODES

1	\$556	8	\$625
2	\$568	9	\$634
3	\$580	10	\$643
4	\$589	11	\$652
5	\$598	12	\$661
6	\$607	L	—
7	\$616		

HON Recommendation: HQTMM.YO.A.H.IM.CU__SB - List Price \$568

HOW TO SPECIFY

<p>Select Model Number</p> <p>HQTMM</p>	<p>Select Control Type</p> <p>YO Synchro-Tilt</p>	<p>Select Arm Type</p> <p>N Armless A Height and Width Adjustable Arms (+ \$75)</p>	<p>Select Caster/Glide</p> <p>H Hard Caster S Soft Caster (+ \$30) G Bell Glide (+ \$25)</p>	<p>Select Mesh Back</p> <p>4-Way Stretch options IM Black</p>	<p>Select Fabric</p> <p>See page 234</p>	<p>Select Base</p> <p>SB Standard Base</p>
<p>HQTMM</p>	<p>YO</p>	<p>A</p>	<p>H</p>	<p>IM</p>	<p>CU10</p>	<p>SB</p>

REVEL™



Revel™ Fidget Stools.

REVEL™

Revel in the movement and give classroom fidgeting a new meaning. Move side to side, back and forth, or spin in a full circle. Revel brings movement and mobility to active learners.



FEATURES

- Seat available in 3 colors, base available in 1.
- Adjust stool height with the push of a button. Stool ranges in height from 13¾"H-18½"H.
- With a slip resistant base and plastic body, you can feel comfortable using the stool in your most creative space with easy cleanup afterwards.
- Tested to hold up to 250 lbs.
- Backed by the HON Full Lifetime Warranty.



HEFS01

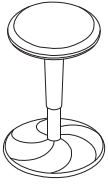

ADJUSTABLE HEIGHT FIDGET STOOL

DIMENSIONS

Depth:	15 ³ / ₈	Seat Height:	13 ³ / ₄ -18 ¹ / ₂
Width:	15 ³ / ₈	Ship Weight:	20.1
Height:	13 ³ / ₄ -18 ¹ / ₂	Cube:	1.4
Seat Depth:	15 ³ / ₈	Weight Rating:	250 lbs.
Seat Width:	15 ³ / ₈		

LIST PRICE

\$250

NOTES: Two buttons integrated in underside of seat for height adjustment control while maintaining a clean aesthetic. Stool seat and base are all plastic for easy cleanability. Anti-slip rubber attached to underside of base allows for comfortable movement of user while maintaining contact with floor. **Base color is similar to HON Loft.**

HOW TO SPECIFY

Select
Model Number

Select
Seat Color

- BZ** Breeze
- S** Charcoal
- BL** Black

HEFS01

BL



Ryder™ Sport Executive Chair with Voi® Desks and Fuse™ Storage.

RYDER™

Take your comfort to the extreme, and elevate the entire office with this high energy chair. The Ryder™ executive chair is the sporty answer to your grandfather's office seating. The unexpected curves and unconventional styling create uncommon comfort. SofThread™ leather paired with carbon fiber pattern creates a sleek look for any modern office.



FEATURES

- Synchro-tilt mechanism offers full range of reclining positions.
- Height-adjustable arms put the support right where you want it.
- Backed by the HON 5-Year Limited Warranty.



HVL149



SPORT EXECUTIVE CHAIR

DIMENSIONS

LIST PRICE

Pneumatic
Swivel
Synchronized Tilt
Tilt Tension
Tilt Lock
Height-adjustable Arms

Depth: 28⁷/₁₀
Width: 27³/₁₀
Height: 48²/₅
Seat Depth: 20¹/₁₀
Seat Width: 22²/₅
Back Width: 22²/₅
Back Height: 29¹/₂

Arm Width: 3¹/₂
Seat to Floor Height: 18⁹/₁₀
Usable Seat Depth: 18⁹/₁₀
Ship Weight: 53 **Ⓢ**
Cube: 8.5
Weight Rating: 250 lbs.

\$517

Functions: **A, E, J, K, L, Q**
(Function Key on pages 16-17)

NOTES: Black SofThread™ Leather with tailored stitching and mock carbon fiber detail. Black frame. Height-adjustable arms. Integrated headrest support. **HON 5-Year Limited Warranty.**

ⓘ Available in Black SofThread™ Leather only.

HON Recommendation: HVL149.SB11 - List Price \$517

HOW TO SPECIFY

Select Model Number

Select Fabric

SB11 Black SofThread™ Leather

H V L 1 4 9 .

S B 1 1

SCATTER™ Guest Chairs

OPEN MARKET



Icon Legend on page 15

HVL606



GUEST CHAIR

Leg Base
Armless
Stacks up to Four High

DIMENSIONS

Depth:	21	Seat to Floor Height:	19
Width:	21¼	Usable Seat Depth:	17½
Height:	32¾	Ship Weight:	16 S
Seat Depth:	17½	Cube:	2.1
Seat Width:	19	Weight Rating:	250 lbs.
Back Width:	18½		
Back Height:	16		

PRICE CODE

Fabric	\$149
Leather	\$179

NOTES: Fabric or Black SofThread™ Leather. Stackable up to four high. Round tube construction. Frame available in Black. Casters and glides ship packaged together for customer's assembly choice. **HON 5-Year Limited Warranty.**

HON Recommendation: HVL606.VA10 - List Price \$149

HVL616



GUEST CHAIR

Leg Base
Arms
Stacks up to Four High

DIMENSIONS

Depth:	21	Arm Width:	20⅝
Width:	23¼	Seat to Floor Height:	19
Height:	32¾	Usable Seat Depth:	17½
Seat Depth:	17½	Ship Weight:	18 S
Seat Width:	19	Cube:	2.1
Back Width:	18½	Weight Rating:	250 lbs.
Back Height:	16		

PRICE CODE

Fabric	\$168
Leather	\$198

NOTES: Fabric or Black SofThread™ Leather. Stackable up to four high. Round tube construction. Frame available in Black. Casters and glides ship packaged together for customer's assembly choice. **HON 5-Year Limited Warranty.**

HON Recommendation: HVL616.VA10 - List Price \$168

HOW TO SPECIFY

<p>Select Model Number</p>	<p>Select Fabric</p> <p>SB11 Black SofThread™ Leather VA10 Black Fabric VA19 Charcoal Fabric VA90 Navy Fabric</p>
<div style="border: 1px solid black; padding: 2px; display: inline-block;">H</div> <div style="border: 1px solid black; padding: 2px; display: inline-block;">V</div> <div style="border: 1px solid black; padding: 2px; display: inline-block;">L</div> <div style="border: 1px solid black; padding: 2px; display: inline-block;">6</div> <div style="border: 1px solid black; padding: 2px; display: inline-block;">0</div> <div style="border: 1px solid black; padding: 2px; display: inline-block;">6</div>	<div style="border: 1px solid black; padding: 2px; display: inline-block;">V</div> <div style="border: 1px solid black; padding: 2px; display: inline-block;">A</div> <div style="border: 1px solid black; padding: 2px; display: inline-block;">1</div> <div style="border: 1px solid black; padding: 2px; display: inline-block;">0</div>

SKIP



Skip shown with Flock® Cylinder Table.

SKIP

It's hard to get creative when you're feeling all buttoned up. That's why workplaces are adding less formal, more dynamic spaces to foster more creativity and connection between workers. Designed to put the fun back in functional, Skip seating offers an engaging, active sit that lets you rock a meeting — literally. When it comes to casual and collaborative seating that's as lively as it is practical, this chair doesn't Skip a beat.



FEATURES

- Built-in handle makes it easy to move around.
- Textured finish is durable, easy to clean and UV resistant.
- Optional cushion stays in place but is not permanently affixed.
- Cushion fabric is easy to wipe clean.

SKIP Collaborative Chair

OPEN MARKET



Icon Legend on page 15

HQQ1



COLLABORATIVE CHAIR

DIMENSIONS

Depth:	35½	Seat to Floor Height:	17
Width:	28	Usable Seat Depth:	17
Height:	31	Ship Weight:	35
Seat Depth:	18	Cube:	20.0
Seat Width:	28	Weight Rating:	275 lbs.
Back Width:	28		
Back Height:	21		

LIST PRICE

\$793

NOTES: HON 5-Year Limited Warranty.

HQQ1CUSH



CUSHION

DIMENSIONS

Depth:	17½	Ship Weight:	5 Ⓞ
Width:	25¾	Cube:	2.0
Height:	1½		

LIST PRICE

\$152

NOTES: HON 5-Year Limited Warranty.

HOW TO SPECIFY

Select Model Number

HQQ1

HOW TO SPECIFY

Select Model Number

HQQ1CUSH.

Select Fabric

SLT Slate
NVY Navy

SLT

SMARTLINK®



SmartLink Chairs shown with Build™ Tables.

SMARTLINK®

SmartLink chairs use a responsive, contoured design to support the way students move, allowing them to turn around, sit sideways, lean back and stay comfortable for longer periods of time. The flexible Learning Curve™ design encourages a wider range of movement, keeping students focused and attentive throughout the day. The lightweight frame with casters or glides make it easy to reconfigure the classroom at a moments notice.



FEATURES

- Available in 11 shell colors.
- Available in multiple sizes to accommodate users of all ages.
- Built-in handle makes chairs easy to move.
- Contoured seat back holds a backpack in place.
- High strength tubular steel frame on 4-Leg and Cantilever models.
- 4-leg chairs stack five high.
- Task Swivel Chairs have a pneumatic seat height adjustment.
- Glides available in nylon or nickel plated steel on 4-Leg models.
- Seat Shell is one-piece injection molded.
- Durable textured powder coated paint finish.
- Warranted for users up to 300 lbs.

SMARTLINK® Options

STUDENT CHAIR MODEL OPTIONS

HSS4L-16B



4-Leg Chair

6", 12", 14", 16" & 18"H

HSSCL-16B



Cantilever Chair

14", 16" & 18"H

HSS4L-24B



4-Leg Stool

24"H

HSS4L-30B



4-Leg Stool

30"H

4-LEG CASTERS/ GLIDES



CODE	DESCRIPTION	PRICE
E	Nylon Glide	+\$0



N	Nickel Steel Glide	+\$0
----------	--------------------	-------------



C	Caster*	+\$196
----------	---------	---------------

**Available on models HSS4L-16B and HSS4L-18B ONLY*

CANTILEVER GLIDES



CODE	DESCRIPTION	PRICE
E	All-purpose Glide Insert	+\$0



F	Felt Glide Insert	+\$36
----------	-------------------	--------------

SHELL COLOR

CODE	DESCRIPTION
RG	Tangelo
CR	Cherry
LM	Lime
CP	Calypso
BU	Surf
RE	Regatta
MB	Mulberry
PT	Platinum
SD	Shadow
LA	Lava
ON	Onyx

FRAME

CODE	DESCRIPTION	PRICE
Y	Chrome*	+\$52

P1 PAINT:

P7A	Textured Charcoal
PK7	Textured Designer White

P2 PAINT:

PLAT	Textured Platinum Metallic
PR8	Textured Silver

P3 PAINT:

P8S	Atom
PJF	Bullseye
P8P	Ember
P8N	Ion
P8J	Iris
P8F	Krypton
P8M	Regatta

**Not available on model HSS4L-06A*

! See full model detail pages for upcharge amounts on paint grades.

TASK CHAIR & STOOL MODEL OPTIONS

HSSTK-18B

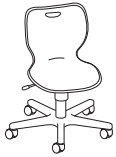

Task Swivel Chair

18"H

HSSST-18B

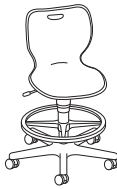

Task Swivel Stool

18"H

TASK CHAIR & STOOL CASTERS/ GLIDES



CODE	DESCRIPTION	PRICE
S	Soft Caster	+\$0



H	Hard Caster	+\$0
----------	-------------	-------------



G	Bell Glide	+\$25
----------	------------	--------------

FRAME

! Black frame only.

SHELL COLOR

CODE	DESCRIPTION
RG	Tangelo
CR	Cherry
LM	Lime
CP	Calypso
BU	Surf
RE	Regatta
MB	Mulberry
PT	Platinum
SD	Shadow
LA	Lava
ON	Onyx

SMARTLINK® Four Leg Chairs

GSA SIN 3372IT



Icon Legend on page 15

HSS4L-06A



6" H CHAIR

Four Legs
Armless

DIMENSIONS

Depth:	17	Back Width:	13 ³ / ₈
Width:	17	Back Height:	11 ⁵ / ₈
Height:	17 ¹ / ₂	Seat to Floor Height:	6
Seat Depth:	14 ¹ / ₄	Usable Seat Depth:	14
Seat Width:	14 ⁵ / ₈	Ship Weight:	37
Seat Height:	6	Cube:	8.6
		Weight Rating:	300 lbs.

LIST PRICE PER CARTON

P1 \$540 <i>(reference single unit @</i>
\$135.00
P2 \$540 <i>(reference single unit @</i>
\$135.00
P3 \$567 <i>(reference single unit @</i>
\$141.75

NOTES: 4-Leg models stack 5-high on floor. 4-Leg chairs ship 4 per carton. Lead-times may vary by shell color.

SmartLink® 4-Leg Chairs are ordered and shipped four (4) chairs per carton. Pricing shown is per carton. Each set of four chairs (one carton) must have the same shell/frame color combination. Ordering 2 of Model HSS4L-06A, HSS4L-12A, HSS4L-14A, HSS4L-16B or HSS4L-18B will result in 2 cartons being shipped, giving you 8 chairs.

HSS4L-12A



12" H CHAIR

Four Legs
Armless

DIMENSIONS

Depth:	17	Back Width:	13 ³ / ₈
Width:	17	Back Height:	11 ⁵ / ₈
Height:	23 ¹ / ₂	Seat to Floor Height:	12
Seat Depth:	14 ¹ / ₄	Usable Seat Depth:	14
Seat Width:	14 ⁵ / ₈	Ship Weight:	45
Seat Height:	12	Cube:	11.9
		Weight Rating:	300 lbs.

LIST PRICE PER CARTON

P1 \$554 <i>(reference single unit @</i>
\$138.50
P2 \$554 <i>(reference single unit @</i>
\$138.50
P3 \$582 <i>(reference single unit @</i>
\$145.50

NOTES: 4-Leg models stack 5-high on floor. 4-Leg chairs ship 4 per carton. Lead-times may vary by shell color.

SmartLink® 4-Leg Chairs are ordered and shipped four (4) chairs per carton. Pricing shown is per carton. Each set of four chairs (one carton) must have the same shell/frame color combination. Ordering 2 of Model HSS4L-06A, HSS4L-12A, HSS4L-14A, HSS4L-16B or HSS4L-18B will result in 2 cartons being shipped, giving you 8 chairs.

HSS4L-14A



14" H CHAIR

Four Legs
Armless

DIMENSIONS

Depth:	17	Back Width:	13 ³ / ₈
Width:	17	Back Height:	11 ⁵ / ₈
Height:	25 ¹ / ₂	Seat to Floor Height:	14
Seat Depth:	14 ¹ / ₄	Usable Seat Depth:	14
Seat Width:	14 ⁵ / ₈	Ship Weight:	49
Seat Height:	14	Cube:	11.9
		Weight Rating:	300 lbs.

LIST PRICE PER CARTON

P1 \$554 <i>(reference single unit @</i>
\$138.50
P2 \$554 <i>(reference single unit @</i>
\$138.50
P3 \$582 <i>(reference single unit @</i>
\$145.50

NOTES: 4-Leg models stack 5-high on floor. 4-Leg chairs ship 4 per carton. Lead-times may vary by shell color.

SmartLink® 4-Leg Chairs are ordered and shipped four (4) chairs per carton. Pricing shown is per carton. Each set of four chairs (one carton) must have the same shell/frame color combination. Ordering 2 of Model HSS4L-06A, HSS4L-12A, HSS4L-14A, HSS4L-16B or HSS4L-18B will result in 2 cartons being shipped, giving you 8 chairs.

HOW TO SPECIFY

Select Model Number <div style="border: 1px solid black; padding: 2px; display: flex; gap: 2px;"> HSS4L-12A </div>	Select Glide Option E Nylon Glide N Nickel Steel Glide C Caster (\$196 upcharge) Caster option not available for models HSS4L-06A, HSS4L-12A or HSS4L-14A <div style="border: 1px solid black; padding: 2px; display: flex; gap: 2px;"> E </div>	Select Shell Color See page 242 <div style="border: 1px solid black; padding: 2px; display: flex; gap: 2px;"> RG </div>	Select Frame Color See page 242 <i>P4 option Chrome (Y) \$52 upcharge. Not available on model HSS4L-06A.</i> <div style="border: 1px solid black; padding: 2px; display: flex; gap: 2px;"> PLAT </div>
---	--	--	--



Icon Legend on page 15

SMARTLINK® Four Leg Chairs

HSS4L-16B

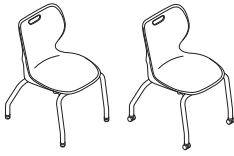

16" H CHAIR

Four Legs
Armless
Functions: (Function Key on pages 16-17)

DIMENSIONS

Depth:	19 ⁵ / ₈	Back Width:	15 ³ / ₈
Width:	19 ¹ / ₄	Back Height:	13 ³ / ₈
Height:	29	Seat to Floor Height:	16
Seat Depth:	16 ¹ / ₄	Usable Seat Depth:	16 ¹ / ₈
Seat Width:	16 ¹ / ₂	Ship Weight:	54
Seat Height:	16	Cube:	15.6
		Weight Rating:	300 lbs.

LIST PRICE PER CARTON

P1 \$583
(reference single unit @
\$145.75)
P2 \$583
(reference single unit @
\$145.75)
P3 \$612
(reference single unit @
\$153.00)

NOTES: 16" H models accept Wire Storage Basket model HSSA-WB1618. Casters are available on 16" H and 18" H chairs only. 4-Leg models stack 5-high on floor. 4-Leg chairs ship 4 per carton. Lead-times may vary by shell color.

SmartLink® 4-Leg Chairs are ordered and shipped four (4) chairs per carton. Pricing shown is per carton. Each set of four chairs (one carton) must have the same shell/frame color combination. Ordering 2 of Model HSS4L-06A, HSS4L-12A, HSS4L-14A, HSS4L-16B or HSS4L-18B will result in 2 cartons being shipped, giving you 8 chairs.

HSS4L-18B

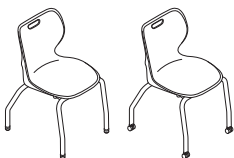

18" H CHAIR

Four Legs
Armless
Functions: (Function Key on pages 16-17)

DIMENSIONS

Depth:	19 ⁵ / ₈	Back Width:	15 ³ / ₈
Width:	19 ¹ / ₂	Back Height:	13 ³ / ₈
Height:	31	Seat to Floor Height:	18
Seat Depth:	16 ¹ / ₄	Usable Seat Depth:	16 ¹ / ₈
Seat Width:	16 ¹ / ₂	Ship Weight:	58
Seat Height:	18	Cube:	15.6
		Weight Rating:	300 lbs.

LIST PRICE PER CARTON

P1 \$583
(reference single unit @
\$145.75)
P2 \$583
(reference single unit @
\$145.75)
P3 \$612
(reference single unit @
\$153.00)

NOTES: 18" H models accept Wire Storage Basket model HSSA-WB1618. Casters are available on 16" H and 18" H chairs only. 4-Leg models stack 5-high on floor. 4-Leg chairs ship 4 per carton. Lead-times may vary by shell color.

SmartLink® 4-Leg Chairs are ordered and shipped four (4) chairs per carton. Pricing shown is per carton. Each set of four chairs (one carton) must have the same shell/frame color combination. Ordering 2 of Model HSS4L-06A, HSS4L-12A, HSS4L-14A, HSS4L-16B or HSS4L-18B will result in 2 cartons being shipped, giving you 8 chairs.

HSSA-WB1618

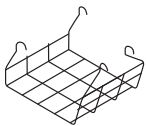

WIRE STORAGE BASKET

DIMENSIONS

Depth:	12 ¹ / ₄	Ship Weight:	14
Width:	15 ³ / ₄	Cube:	1.6
Height:	9 ³ / ₄		

LIST PRICE

\$138

NOTES: Ships 4 per carton.

- For 16" and 18" Chairs only. Chrome finish only.
- Cannot be stacked when utilizing the Wire Storage Basket.

OPEN MARKET

HGDK3-F



GLIDE KIT

Ship Weight:	2
Cube:	0.2

LIST PRICE

\$124

NOTES: For 4-Leg SmartLink®. Recommended for use on VCT flooring. Caps easily and securely snap over the existing nylon swivel glide. Kit includes 100 caps for 25 chairs or desks. Field installed.

- Must be ordered with a configurable end product. If ordered separately, not on GSA Contract.

OPEN MARKET

HOW TO SPECIFY

<p>Select Model Number</p> <p>H S S 4 L - 1 8 B</p>	<p>Select Glide Option</p> <p>E Nylon Glide N Nickel Steel Glide C Caster (\$196 upcharge) Caster option not available for models HSS4L-06A, HSS4L-12A or HSS4L-14A</p> <p>E</p>	<p>Select Shell Color</p> <p>See page 242</p> <p>R G</p>	<p>Select Frame Color</p> <p>See page 242 <i>P4 option Chrome (Y) \$52 upcharge. Not available on model HSS4L-06A.</i></p> <p>P L A T</p>
--	--	---	--



SMARTLINK®

Four Leg Stools

HSS4L-24B



24" H STOOL

Four Legs

DIMENSIONS

Depth:	21½	Back Width:	15⅝
Width:	22	Back Height:	13⅝
Height:	38¼	Seat to Floor Height:	24
Seat Depth:	16¼	Usable Seat Depth:	30
Seat Width:	16½	Ship Weight:	30
Seat Height:	24	Cube:	16.8
		Weight Rating:	300 lbs.

LIST PRICE BY PAINT GRADE

P1	P2	P3
\$283	\$283	\$298

NOTES: Stacks 5-high on floor. Lead time may vary by shell color.

HSS4L-30B



30" H STOOL

Four Legs

DIMENSIONS

Depth:	23½	Back Width:	15⅝
Width:	22⅝	Back Height:	13⅝
Height:	43¾	Seat to Floor Height:	30
Seat Depth:	16¼	Usable Seat Depth:	30
Seat Width:	16½	Ship Weight:	31
Seat Height:	30	Cube:	19.1
		Weight Rating:	300 lbs.

LIST PRICE BY PAINT GRADE

P1	P2	P3
\$298	\$298	\$313

NOTES: Stacks up to 5-high on floor. Lead time may vary by shell color.

HOW TO SPECIFY

Select Model Number

HSS4L-24B

Select Glide Option

- E Nylon Glide
- N Nickel Steel Glide

E

Select Shell Color

See page 242

RG

Select Frame Color

See page 242
P4 option Chrome (Y) \$52 upcharge

PLAT

SMARTLINK® Cantilever Chairs

GSA SIN 3372IT



Icon Legend on page 15

HSSCL-18B



18" H CHAIR

Cantilever Base
Armless

DIMENSIONS

Depth:	21 ³ / ₄	Back Width:	15 ³ / ₈
Width:	22 ³ / ₄	Back Height:	13 ³ / ₈
Height:	31 ¹ / ₄	Seat to Floor Height:	18 ¹ / ₄
Seat Depth:	16 ¹ / ₈	Usable Seat Depth:	16 ¹ / ₈
Seat Width:	16 ¹ / ₂	Ship Weight:	80
Seat Height:	18	Cube:	23.7
		Weight Rating:	300 lbs.

LIST PRICE PER CARTON

P1 \$845 <i>(reference single unit @</i> \$211.25
P2 \$845 <i>(reference single unit @</i> \$211.25
P3 \$887 <i>(reference single unit @</i> \$221.75

NOTES: Cantilever models stack 5-high on floor. Cantilever chairs ship 4 per carton. Lead-times may vary by shell color.

SmartLink® Cantilever Chairs are ordered and shipped four (4) chairs per carton. Pricing shown is per carton. Each set of four chairs (one carton) must have the same shell/frame color combination. Ordering 2 of Model HSSCL-18B will result in 2 cartons being shipped, giving you 8 chairs.

HSSCL-16B



16" H CHAIR

Cantilever Base
Armless

DIMENSIONS

Depth:	21 ³ / ₄	Back Width:	15 ³ / ₈
Width:	22 ³ / ₄	Back Height:	13 ³ / ₈
Height:	29 ¹ / ₄	Seat to Floor Height:	16 ¹ / ₄
Seat Depth:	16 ¹ / ₈	Usable Seat Depth:	16 ¹ / ₈
Seat Width:	16 ¹ / ₂	Ship Weight:	55
Seat Height:	16	Cube:	16.8
		Weight Rating:	300 lbs.

LIST PRICE PER CARTON

P1 \$804 <i>(reference single unit @</i> \$201.00
P2 \$804 <i>(reference single unit @</i> \$201.00
P3 \$844 <i>(reference single unit @</i> \$211.00

NOTES: Cantilever models stack 5-high on floor. Cantilever chairs ship 4 per carton. Lead-times may vary by shell color.

SmartLink® Cantilever Chairs are ordered and shipped four (4) chairs per carton. Pricing shown is per carton. Each set of four chairs (one carton) must have the same shell/frame color combination. Ordering 2 of Model HSSCL-18B will result in 2 cartons being shipped, giving you 8 chairs.

HSSCL-14A



14" H CHAIR

Cantilever Base
Armless

DIMENSIONS

Depth:	21 ³ / ₄	Back Width:	15 ³ / ₈
Width:	22 ³ / ₄	Back Height:	13 ³ / ₈
Height:	27 ¹ / ₄	Seat to Floor Height:	14 ¹ / ₄
Seat Depth:	16 ¹ / ₈	Usable Seat Depth:	16 ¹ / ₈
Seat Width:	16 ¹ / ₂	Ship Weight:	52
Seat Height:	14	Cube:	16.8
		Weight Rating:	300 lbs.

LIST PRICE PER CARTON

P1 \$789 <i>(reference single unit @</i> \$197.25
P2 \$789 <i>(reference single unit @</i> \$197.25
P3 \$828 <i>(reference single unit @</i> \$207.00

NOTES: Cantilever models stack 5-high on floor. Cantilever chairs ship 4 per carton. Lead-times may vary by shell color.

SmartLink® Cantilever Chairs are ordered and shipped four (4) chairs per carton. Pricing shown is per carton. Each set of four chairs (one carton) must have the same shell/frame color combination. Ordering 2 of Model HSSCL-18B will result in 2 cartons being shipped, giving you 8 chairs.

HOW TO SPECIFY

Select Model Number <div style="border: 1px solid black; padding: 2px; display: inline-block;">H S S C L - 1 8 B</div>	Select Glide Option E All-purpose Glide Insert (no upcharge) F Felt Glide Insert (\$36 list upcharge; \$9 per single unit)	Select Shell Color See page 242 <div style="border: 1px solid black; padding: 2px; display: inline-block;">R G</div>	Select Frame Color See page 242 <i>P4 option Chrome (Y) \$52 upcharge</i> <div style="border: 1px solid black; padding: 2px; display: inline-block;">P L A T</div>
--	---	---	--



HSSTK-18B

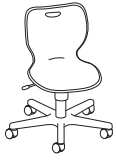

18" H TASK CHAIR

Pneumatic
Swivel

DIMENSIONS

Depth:	22 ⁵ / ₈	Back Width:	15 ³ / ₈
Width:	22 ¹ / ₂	Back Height:	13 ³ / ₈
Height:	34 ³ / ₄	Seat to Floor Height:	16-21
Seat Depth:	16 ¹ / ₄	Usable Seat Depth:	16 ¹ / ₈
Seat Width:	16 ¹ / ₂	Ship Weight:	23
Seat Height:	18	Cube:	5.2
		Weight Rating:	300 lbs.

LIST PRICE PER CARTON

\$281

NOTES: Task Swivel Chair has a pneumatic seat height adjustment. Swivel Task Chair and Stool ship one per carton. Lead-times may vary by shell color.

ⓘ Black frame only.

HSSST-18B

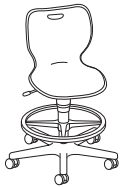

18" H TASK STOOL

Pneumatic
Swivel
Adjustable Footring

DIMENSIONS

Depth:	24 ¹ / ₄	Back Width:	15 ³ / ₈
Width:	25 ³ / ₄	Back Height:	13 ³ / ₈
Height:	45 ¹ / ₂	Seat to Floor Height:	22-32
Seat Depth:	16 ¹ / ₄	Usable Seat Depth:	16 ¹ / ₈
Seat Width:	16 ¹ / ₂	Ship Weight:	28
Seat Height:	18	Cube:	12.8
		Weight Rating:	300 lbs.

LIST PRICE PER CARTON

\$378

NOTES: Stool has an adjustable footring. Swivel Task Chair and Stool ship one per carton. Lead-times may vary by shell color.

ⓘ Black frame only.

HOW TO SPECIFY

Select
Model Number

H S S T K - 1 8 B

Select
Glide Option

- S** Soft Caster (no upcharge)
- H** Hard Caster (no upcharge)
- G** Bell Glide (\$25 upcharge)

S

Select
Shell Color

See page 243

R G

SOLUTIONS SEATING® 4000 SERIES



Solutions Managerial Mid-Back Chair shown with 34000 Series Desk and Brigade® 700 Series Lateral Files.

SOLUTIONS SEATING® 4000 SERIES

Looking for the perfect answer for your task and guest chair needs? HON has four Solutions for everything from workstations to open areas. The Solutions series includes a high-back and mid-back task chair, as well as matching four-leg and sled base guest chairs. The floating backrest provides ergonomic support for your spine. The tilt mechanism delivers a natural recline. Solutions are the chairs that really live up to their name.



GUEST CHAIR FEATURES

- Guest chairs feature molded polymer outer back shell for added durability.
- Back cushion enhances lumbar support and minimizes fatigue.
- Available in hundreds of quality HON fabrics.
- Warranted for users up to 300 lbs.

TASK CHAIR FEATURES

- One-touch seat height adjustment easily moves the seat up and down.
- Tilt tension controls the rate and ease of recline.
- Tilt lock allows the user to lock out the tilt function.
- 360-degree swivel provides freedom of movement in any direction.
- Model H4001 has a fully-upholstered outer back.
- Model H4002 has a molded polymer outer back shell.
- Back cushion enhances lumbar support and minimizes fatigue.
- Dual-wheeled casters roll effortlessly and quietly.
- Available in hundreds of quality HON fabrics.
- Warranted for users up to 300 lbs.

SOLUTIONS SEATING®

4000 Series Options

MODEL OPTIONS

H4001



Executive High-Back

Pneumatic, Swivel, Tilt, Tilt Tension, Tilt Lock, Loop Arms

H4002



Managerial Mid-Back

Pneumatic, Swivel, Tilt, Tilt Tension, Tilt Lock, Loop Arms

H4003



Guest Chair

Leg Base, Arms

H4008



Guest Chair

Sled Base, Arms

CASTERS



CODE	DESCRIPTION	PRICE
H	Hard Caster	+\$0



S	Soft Caster	+\$30
---	-------------	--------------

*Specify for models H4001 and H4002 only

FRAME

CODE	DESCRIPTION	PRICE
T	Black	+\$0

HON BRANDED FABRICS

GRADE 1

Attire
Centurion
Compass
Contourett Polyurethane
Dapper
Hamilton
Inertia
Optic

GRADE 2

Appoint Seating
Clyde
Dotty
Rush
Seed
Spin Seating
Whisper Vinyl

GRADE 3

In Season
Purl
Silvertex™ Vinyl

For a complete list of fabrics, including partnership fabrics, go to hon.com/fabricsandfinishes.

Reference Fabric Color Combinations on pages 18-22 for color codes and legend on page 19 for lead times. COM yardage shown is for Pattern Cut only. Contact Customer Service for Railroaded yardage requirements. For additional HON to Supply COM fabric grade pricing, go to honready.hon.com and click on the HON to Supply COM link.

For Fire Code model, availability and ordering method, refer to pages 26-29. Available on select models, contact HON Customer Support for availability.

SOLUTIONS SEATING®

4000 Series

GSA SIN 33721



Icon Legend on page 15

H4001



EXECUTIVE HIGH-BACK

Pneumatic
Swivel
Tilt
Tilt Tension
Tilt Lock
Loop Arms
Functions: **A, E, F, K, L**
(Function Key on pages 16-17)

DIMENSIONS

Depth: 27
Width: 26
Height: 39³/₄
Seat Depth: 18
Seat Width: 20
Back Width: 20¹/₂
Back Height: 20³/₄
Arm Width: 20¹/₄
Seat to Floor Height: 16³/₄-21³/₄
Usable Seat Depth: 17³/₄
Ship Weight: 45 **Ⓔ**
Cube: 10.3
COM: 1.5
Weight Rating: 250 lbs.

FABRIC PRICE CODES

1	\$473	8	\$680
2	\$509	9	\$707
3	\$545	10	\$734
4	\$572	11	\$761
5	\$599	12	\$788
6	\$626	L	—
7	\$653		

H4002

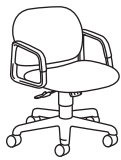

MANAGERIAL MID-BACK

Pneumatic
Swivel
Tilt
Tilt Tension
Tilt Lock
Loop Arms
Functions: **A, E, F, K, L**
(Function Key on pages 16-17)

DIMENSIONS

Depth: 26¹/₄
Width: 26
Height: 35¹/₂
Seat Depth: 18
Seat Width: 20
Back Width: 21
Back Height: 15
Arm Width: 18³/₄
Seat to Floor Height: 16³/₄-21³/₄
Usable Seat Depth: 17³/₄
Ship Weight: 38 **Ⓔ**
Cube: 8.6
COM: 1.0
Weight Rating: 250 lbs.

FABRIC PRICE CODES

1	\$428	8	\$566
2	\$452	9	\$584
3	\$476	10	\$602
4	\$494	11	\$620
5	\$512	12	\$638
6	\$530	L	—
7	\$548		

H4003



GUEST CHAIR

Leg Base
Arms

DIMENSIONS

Depth: 24¹/₂
Width: 23¹/₂
Height: 32
Seat Depth: 18
Seat Width: 20
Back Width: 21
Back Height: 15
Arm Width: 18³/₄
Seat to Floor Height: 19¹/₄
Usable Seat Depth: 18¹/₄
Ship Weight: 29
Cube: 12.6
COM: 1.0
Weight Rating: 250 lbs.

FABRIC PRICE CODES

1	\$324	8	\$462
2	\$348	9	\$480
3	\$372	10	\$498
4	\$390	11	\$516
5	\$408	12	\$534
6	\$426	L	—
7	\$444		

H4008



GUEST CHAIR

Sled Base
Arms

DIMENSIONS

Depth: 25¹/₂
Width: 23¹/₂
Height: 32¹/₂
Seat Depth: 18
Seat Width: 20
Back Width: 21
Back Height: 15
Arm Width: 19
Seat to Floor Height: 19¹/₄
Usable Seat Depth: 18¹/₄
Ship Weight: 33
Cube: 12.6
COM: 1.0
Weight Rating: 250 lbs.

FABRIC PRICE CODES

1	\$361	8	\$499
2	\$385	9	\$517
3	\$409	10	\$535
4	\$427	11	\$553
5	\$445	12	\$571
6	\$463	L	—
7	\$481		

HON Recommendation: H4001.H.CU__T - List Price \$473

H4008.CU__T - List Price \$361

HOW TO SPECIFY

<p>Select Model Number</p> <p>H 4 0 0 8 .</p>	<p>Select Caster</p> <p>H Hard Caster S Soft Caster (+ \$30) Specify for models H4001 and H4002 only</p> <p>H .</p>	<p>Select Fabric</p> <p>See page 249</p> <p>C U 1 0 .</p>	<p>Select Frame</p> <p>T Black</p> <p>T</p>
--	--	--	--

SOLVE®



Solve Task Chairs and Stools.

SOLVE®

If you want to make a powerful statement, simply have a seat. With three back materials and an optional adjustable lumbar support, Solve answers the need for a higher level of personalization. Solve task chairs feature a geometric ReActiv® back to create a contemporary look, while the 4-Way Stretch mesh back offers a softer, more relaxed feel. The synchronized seat and back move in harmony with the user to provide continuous comfort that can be customized. Helping anyone achieve optimal balance, proper alignment and lumbar support, Solve is an ideal solution for everywhere and everybody.



FEATURES

- Synchronized seat and back create continuous comfort.
- Waterfall seat edge encourages leg circulation.
- Optional seat depth adjustment adapts to users of various heights.
- ReActiv® back design moves with your body to provide continuous support and airflow for lasting comfort.
- Available with three control types — synchro-tilt, synchro-tilt with seat slider and advanced synchro-tilt.
- Choose from four different arm options — armless, fixed, height- and width-adjustable or all-adjustable arms.
- Optional lumbar support delivers long-lasting comfort.
- Available with bell glides, hard casters or soft casters.
- Upholstered ReActiv® back offers all the benefits of the ReActiv® back with a fabric cover for additional comfort.
- Back upholstery available in one of six attractive fabrics.
- Choose from 3 frame options: Black, Titanium and White.
- Available in five mesh back and seven lumbar colors and thousands of fabrics.
- Warranted for users up to 300 lbs.

SOLVE[®] Options

MODEL OPTIONS

HSLVTMM



Mid-Back Task (4-Way Stretch Back)

Pneumatic, Swivel, Synchro-tilt, Tilt Tension, Tilt Lock

HSLVSMM



Stool (4-Way Stretch Back)

Pneumatic, Swivel, Synchro-tilt, Tilt Tension, Tilt Lock

HSLVTMMS



Mid-Back Task (4-Way Stretch Back) with Designer White frame

Pneumatic, Swivel, Synchro-tilt, Tilt Tension, Tilt Lock

HSLVSMMS



Stool (4-Way Stretch Back) with Designer White frame

Pneumatic, Swivel, Synchro-tilt, Tilt Tension, Tilt Lock

HSLVTMR



Mid-Back Task (ReActiv[®] Back)

Pneumatic, Swivel, Synchro-tilt, Tilt Tension, Tilt Lock

HSLVSMR



Stool (ReActiv[®] Back)

Pneumatic, Swivel, Synchro-tilt, Tilt Tension, Tilt Lock

HSLVTMRS



Mid-Back Task (ReActiv[®] Back) with Designer White frame

Pneumatic, Swivel, Synchro-tilt, Tilt Tension, Tilt Lock

HSLVSMRS



Stool (ReActiv[®] Back) with Designer White frame

Pneumatic, Swivel, Synchro-tilt, Tilt Tension, Tilt Lock

HSLVTMU



Mid-Back Task (Upholstered Back)

Pneumatic, Swivel, Synchro-tilt, Tilt Tension, Tilt Lock

HSLVSMU



Stool (Upholstered Back)

Pneumatic, Swivel, Synchro-tilt, Tilt Tension, Tilt Lock

HSLVTMUS



Mid-Back Task (Upholstered Back) with Designer White frame

Pneumatic, Swivel, Synchro-tilt, Tilt Tension, Tilt Lock

HSLVSMUS







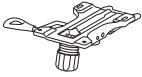
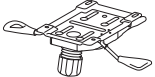
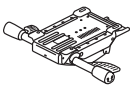

Stool (Upholstered Back) with Designer White frame

Pneumatic, Swivel, Synchro-tilt, Tilt Tension, Tilt Lock

MECHANISM	CODE	DESCRIPTION	PRICE
	Y0	Synchro-Tilt A, E, J, K, L	+\$0
	Y1	Synchro-Tilt w/Seat Slider A, D, E, J, K, L	+\$20
	Y2	Advanced Synchro-Tilt A, D, E, J, L, A-D	+\$65

**Y2 control not available on stool models*

ARM STYLE	CODE	DESCRIPTION	PRICE
	N	Armless	+\$0
	F	Fixed Arms	+\$65
		<i>*Not available on Designer White models</i>	
	A	Height and Width Adjustable Arms	+\$75
	V	All-Adjustable Arms (includes Pivot)	+\$115
		<i>*Not available on Designer White models</i>	

CASTERS/ GLIDE	CODE	DESCRIPTION	PRICE
	H	Hard Caster	+\$0
	S	Soft Caster	+\$30
	R	Roll Control Caster	+\$50
	G	Bell Glide	+\$25

BACK STYLE	CODE	DESCRIPTION	PRICE
		<i>4-Way Stretch mesh back options:</i>	
	IM	Black	+\$0
	IF	Fog	+\$0
	IC	Charcoal	+\$0
	IH	Chai	+\$0
	IY	Navy	+\$0
		<i>ReActiv® back options:</i>	
	OS	Charcoal	+\$0
	DW	Designer White	+\$0
	TI	Titanium	+\$0
		<i>Fabric options:</i>	
	COMF46	Bittersweet	+\$0
	COMF10	Ink	+\$0
	COMF82	Meadow	+\$0
	COMF90	Midnight	+\$0
	COMF22	Putty	+\$0
	COMF19	Sterling	+\$0

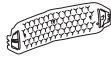
LUMBAR	CODE	DESCRIPTION	PRICE
	NL	No Lumbar	+\$0
	BL	Black Adjustable Lumbar	+\$30
	BY	Bullseye Adjustable Lumbar	+\$30
	DW	Designer White Adjustable Lumbar	+\$30
	KT	Krypton Adjustable Lumbar	+\$30
	MR	Ember Adjustable Lumbar	+\$30
	RE	Regatta Adjustable Lumbar	+\$30
	TL	Titanium Adjustable Lumbar	+\$30

BASE	CODE	DESCRIPTION	PRICE
	SB	Standard Base	+\$0

FRAME	CODE	DESCRIPTION	PRICE
	T	Black	+\$0
	TI	Titanium	+\$35
	DW	Designer White	+\$35

HON BRANDED FABRICS

GRADE 1	GRADE 2	GRADE 3	GRADE L
Attire	Appoint Seating	In Season	Denver Leather (Seat Only)
Centurion	Clyde	Purl	
Compass	Dotty	Silvertex™ Vinyl	
Compass Foam	Rush		
Contourett Polyurethane	Seed		
Dapper	Spin Seating		
Hamilton	Whisper Vinyl		
Inertia			
Optic			

For a complete list of fabrics, including partnership fabrics, go to hon.com/fabricsandfinishes.

Reference Fabric Color Combinations on pages 18-22 for color codes and legend on page 19 for lead times.

🔥 For Fire Code model, availability and ordering method, refer to pages 26-29. Available on select models, contact HON Customer Support for availability.

DIMENSIONS

NOTE: When selecting the .TI Titanium or .DW Designer White frame option, the chair's back frame, arms, and base will match. 4-Way Stretch, ReActiv[®], and/or lumbar color must be selected separately.

MODEL		HSLVTMM /HSLVTMMS	HSLVSMM /HSLVSMS	HSLVTMR /HSLVTMRS	HSLVSMR /HSLVSMRS	HSLVTMU /HSLVTMUS	HSLVSMU /HSLVSMUS
Overall Width Armless		29½"	29½"	29½"	29½"	29½"	29½"
Overall Width with Arms	(A)	29½"	29½"	29½"	29½"	29½"	29½"
Overall Depth		29½"	29½"	29½"	29½"	29½"	29½"
Overall Height – Max	(Y0/Y1) (Y2)	41¾" 42½"	52¾" —	41¾" 42½"	52¾" —	41¾" 42½"	52¾" —
Seat Width		19"	19"	19"	19"	19"	19"
Seat Depth (Cushion)		19¼"	19¼"	19¼"	19¼"	19¼"	19¼"
Usable Seat Depth	(Y0) (Y1) (Y2)	17⅝" 16¼"-18½" 16¼"-19¼"	17⅝" 16¼"-18½" —	17⅝" 16¼"-18½" 16¼"-19¼"	17⅝" 16¼"-18½" —	17⅝" 16¼"-18½" 16¼"-19¼"	17⅝" 16¼"-18½" —
Seat Height	(Y0/Y1) (Y2)	16¾"-21¾" 17½"-22½"	22¾"-32¾" —	16¾"-21¾" 17½"-22½"	22¾"-32¾" —	16¾"-21¾" 17½"-22½"	22¾"-32¾" —
Back Width		18¼"	18¼"	18¼"	18¼"	18¼"	18¼"
Back Height		21½"	21½"	21½"	21½"	21½"	21½"
Ship Weight Armless	(Y0) (Y1) (Y2)	40 Ⓢ 42 Ⓢ 45 Ⓢ	45 Ⓢ 47 Ⓢ —	41 Ⓢ 43 Ⓢ 46 Ⓢ	46 Ⓢ 48 Ⓢ —	41 Ⓢ 43 Ⓢ 46 Ⓢ	46 Ⓢ 48 Ⓢ —
Ship Weight with Arms	(Y0) (Y1) (Y2)	44 Ⓢ 46 Ⓢ 49 Ⓢ	49 Ⓢ 51 Ⓢ —	45 Ⓢ 47 Ⓢ 50 Ⓢ	50 Ⓢ 52 Ⓢ —	45 Ⓢ 47 Ⓢ 50 Ⓢ	50 Ⓢ 52 Ⓢ —
Width Between Arms		17½"-20"	17½"-20"	17½"-20"	17½"-20"	17½"-20"	17½"-20"
COM		1.0	1.0	1.0	1.0	1.0	1.0
Weight Capacity		300 lbs	300 lbs	300 lbs	300 lbs	300 lbs	300 lbs



Icon Legend on page 15

HSLVTMM

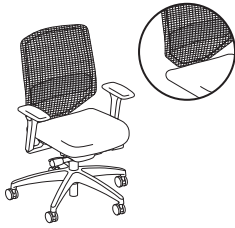

MID-BACK TASK

- 4-Way Stretch Back**
- Pneumatic
- Swivel
- Synchro-tilt
- Tilt Tension
- Tilt Lock

DIMENSIONS

- Seat Depth: 19¼
- Seat Width: 19
- Back Width: 18¼
- Back Height: 21½
- Arm Width: 17½-20
- Cube: 10.8
- Weight Rating: 300 lbs.

FABRIC PRICE CODES

1	\$472	8	\$541
2	\$484	9	\$550
3	\$496	10	\$559
4	\$505	11	\$568
5	\$514	12	\$577
6	\$523	L	\$572
7	\$532		

NOTES: Please reference pages 253-254 for additional specifications and mechanism information.

HSLVTMMS

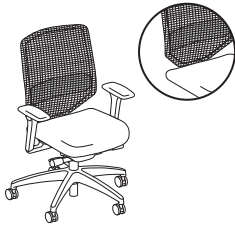

MID-BACK TASK IN DESIGNER WHITE

- 4-Way Stretch Back**
- Pneumatic
- Swivel
- Synchro-tilt
- Tilt Tension
- Tilt Lock

DIMENSIONS

- Seat Depth: 19¼
- Seat Width: 19
- Back Width: 18¼
- Back Height: 21½
- Arm Width: 17½-20
- Cube: 10.8
- Weight Rating: 300 lbs.

FABRIC PRICE CODES

1	\$472	8	\$541
2	\$484	9	\$550
3	\$496	10	\$559
4	\$505	11	\$568
5	\$514	12	\$577
6	\$523	L	\$572
7	\$532		

OPEN MARKET

NOTES: Please reference pages 253-254 for additional specifications and mechanism information.

HON Recommendation: HSLVTMM.Y1.A.S.IM.CU__BL.SB.T - List Price \$627

HOW TO SPECIFY

Select Model Number	Select Control Type	Select Arm Type	Select Caster/Glide	Select Mesh Back	Select Fabric	Select Lumbar	Select Base	Select Frame
	Y0 Synchro-Tilt Y1 Synchro-Tilt w/ Seat Slider (+ \$20) Y2 Advanced Synchro-Tilt (+ \$65)	HSLVTMM Options N Armless F Fixed Arms (+ \$65) A Height and Width Adjustable Arms (+ \$75) V All-Adjustable Arms (includes pivot) (+ \$115) HSLVTMMS Options ADW Height and Width Adjustable Arms (+ \$75) Available for model HSLVTMMS only	H Hard Caster (+ \$30) S Soft Caster (+ \$30) G Bell Glide (+ \$25) R Roll Control Caster (+ \$50)	4-Way Stretch options IM Black IF Fog IC Charcoal IH Chai IY Navy	See page 254	NL No Lumbar BL Black Adjustable Lumbar (+ \$30) BY Bullseye Adjustable Lumbar (+ \$30) DW Designer White Adjustable Lumbar (+ \$30) KT Krypton Adjustable Lumbar (+ \$30) MR Ember Adjustable Lumbar (+ \$30) RE Regatta Adjustable Lumbar (+ \$30) TL Titanium Adjustable Lumbar (+ \$30)	SB Standard Base	HSLVTMM Options T Black TI Titanium (+ \$35) HSLVTMMS Options DW Designer White (+ \$35) Available for model HSLVTMMS only
H S L V T M M .	Y 1 .	A .	S .	I M .	C U 1 0 .	B L .	S B .	T



HSLVSMM

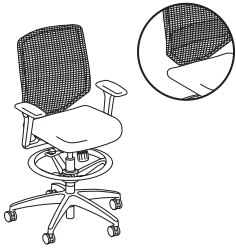

STOOL

- 4-Way Stretch Back**
- Pneumatic
- Swivel
- Synchro-tilt
- Tilt Tension
- Tilt Lock

DIMENSIONS

Seat Depth:	19¼	Arm Width:	17½-20
Seat Width:	19	Cube:	10.8
Back Width:	18¼	Weight Rating:	300 lbs.
Back Height:	21½		

FABRIC PRICE CODES

1	\$528	8	\$597
2	\$540	9	\$606
3	\$552	10	\$615
4	\$561	11	\$624
5	\$570	12	\$633
6	\$579	L	\$628
7	\$588		

NOTES: Please reference pages 253-254 for additional specifications and mechanism information.

HSLVSMMS



STOOL IN DESIGNER WHITE

- 4-Way Stretch Back**
- Pneumatic
- Swivel
- Synchro-tilt
- Tilt Tension
- Tilt Lock

DIMENSIONS

Seat Depth:	19¼	Arm Width:	17½-20
Seat Width:	19	Cube:	10.8
Back Width:	18¼	Weight Rating:	300 lbs.
Back Height:	21½		

FABRIC PRICE CODES

1	\$528	8	\$597
2	\$540	9	\$606
3	\$552	10	\$615
4	\$561	11	\$624
5	\$570	12	\$633
6	\$579	L	\$628
7	\$588		

OPEN MARKET

NOTES: Please reference pages 253-254 for additional specifications and mechanism information.

HON Recommendation: HSLVSMM.Y1.A.S.IM.CU__BL.SB.T - List Price \$683

HOW TO SPECIFY

Select Model Number	Select Control Type	Select Arm Type	Select Caster/Glide	Select Mesh Back	Select Fabric	Select Lumbar	Select Base	Select Frame
YO Synchro-Tilt Y1 Synchro-Tilt w/ Seat Slider (+ \$20)	H Hard Caster S Soft Caster (+ \$30) G Bell Glide (+ \$25) R Roll Control Caster (+ \$50)	N Armless F Fixed Arms (+ \$65) A Height and Width Adjustable Arms (+ \$75) V All-Adjustable Arms (includes pivot) (+ \$115)	IM Black IF Fog IC Charcoal IH Chai IY Navy	See page 254	NL No Lumbar BL Black Adjustable Lumbar (+ \$30) BY Bullseye Adjustable Lumbar (+ \$30) DW Designer White Adjustable Lumbar (+ \$30) KT Krypton Adjustable Lumbar (+ \$30) MR Ember Adjustable Lumbar (+ \$30) RE Regatta Adjustable Lumbar (+ \$30) TL Titanium Adjustable Lumbar (+ \$30)	SB Standard Base	HSLVSMM Options T Black TI Titanium (+ \$35) HSLVSMMS Options DW Designer White (+ \$35) <i>Available for model HSLVSMMS only</i>	
H S L V S M M .	Y 1 .	A .	S .	I M .	C U 1 0 .	B L .	S B .	T



Icon Legend on page 15

HSLVTMR

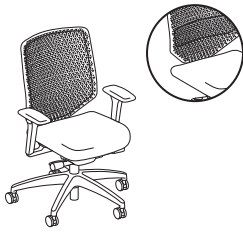

MID-BACK TASK

- ReActiv® Back**
- Pneumatic
- Swivel
- Synchro-tilt
- Tilt Tension
- Tilt Lock

DIMENSIONS

- Seat Depth: 19¼
- Seat Width: 19
- Back Width: 18¾
- Back Height: 21½
- Arm Width: 17½-20
- Cube: 10.8
- Weight Rating: 300 lbs.

FABRIC PRICE CODES

- | | | | |
|---|-------|----|-------|
| 1 | \$504 | 8 | \$573 |
| 2 | \$516 | 9 | \$582 |
| 3 | \$528 | 10 | \$591 |
| 4 | \$537 | 11 | \$600 |
| 5 | \$546 | 12 | \$609 |
| 6 | \$555 | L | \$604 |
| 7 | \$564 | | |

NOTES: Please reference pages 253-254 for additional specifications and mechanism information.

HSLVTMRS

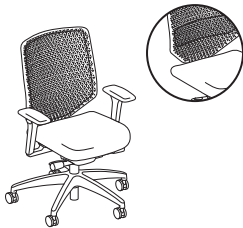

MID-BACK TASK IN DESIGNER WHITE

- ReActiv® Back**
- Pneumatic
- Swivel
- Synchro-tilt
- Tilt Tension
- Tilt Lock

DIMENSIONS

- Seat Depth: 19¼
- Seat Width: 19
- Back Width: 18¾
- Back Height: 21½
- Arm Width: 17½-20
- Cube: 10.8
- Weight Rating: 300 lbs.

FABRIC PRICE CODES

- | | | | |
|---|-------|----|-------|
| 1 | \$504 | 8 | \$573 |
| 2 | \$516 | 9 | \$582 |
| 3 | \$528 | 10 | \$591 |
| 4 | \$537 | 11 | \$600 |
| 5 | \$546 | 12 | \$609 |
| 6 | \$555 | L | \$604 |
| 7 | \$564 | | |

OPEN MARKET

NOTES: Please reference pages 253-254 for additional specifications and mechanism information.

HON Recommendation: HSLVTMR.Y1.A.H.OS.CU__NL.SB.T - List Price \$599

HOW TO SPECIFY

Select Model Number	Select Control Type	Select Arm Type	Select Caster/Glide	Select Back Color	Select Fabric	Select Lumbar	Select Base	Select Frame
	Y0 Synchro-Tilt Y1 Synchro-Tilt w/ Seat Slider (+ \$20) Y2 Advanced Synchro-Tilt (+ \$65)	HSLVTMR Options N Armless F Fixed Arms (+ \$65) A Height and Width Adjustable Arms (+ \$75) V All-Adjustable Arms (includes pivot) (+ \$115) HSLVTMRS Options ADW Height and Width Adjustable Arms (+ \$75) <i>Available for model HSLVTMRS only</i>	H Hard Caster (+ \$30) S Soft Caster (+ \$30) G Bell Glide (+ \$25) R Roll Control Caster (+ \$50)	OS Charcoal TI Titanium DW Designer White	See page 254	NL No Lumbar BL Black Adjustable Lumbar (+ \$30) BY Bullseye Adjustable Lumbar (+ \$30) DW Designer White Adjustable Lumbar (+ \$30) KT Krypton Adjustable Lumbar (+ \$30) MR Ember Adjustable Lumbar (+ \$30) RE Regatta Adjustable Lumbar (+ \$30) TL Titanium Adjustable Lumbar (+ \$30)	SB Standard Base	HSLVTMR Options T Black TI Titanium (+ \$35) HSLVTMRS Options DW Designer White (+ \$35) <i>Available for model HSLVTMRS only</i>
H S L V T M R	Y 1	A	H	O S	C U 1 0	N L	S B	T



Icon Legend on page 15

HSLVSMR



STOOL

ReActiv® Back
Pneumatic
Swivel
Synchro-tilt
Tilt Tension
Tilt Lock

DIMENSIONS

Seat Depth: 19¼ Arm Width: 17½-20
Seat Width: 19 Cube: 10.8
Back Width: 18¼ Weight Rating: 300 lbs.
Back Height: 21½

FABRIC PRICE CODES

1	\$560	8	\$629
2	\$572	9	\$638
3	\$584	10	\$647
4	\$593	11	\$656
5	\$602	12	\$665
6	\$611	L	\$660
7	\$620		

NOTES: Please reference pages 253-254 for additional specifications and mechanism information.

HSLVSMRS



STOOL IN DESIGNER WHITE

ReActiv® Back
Pneumatic
Swivel
Synchro-tilt
Tilt Tension
Tilt Lock

DIMENSIONS

Seat Depth: 19¼ Arm Width: 17½-20
Seat Width: 19 Cube: 10.8
Back Width: 18¼ Weight Rating: 300 lbs.
Back Height: 21½

FABRIC PRICE CODES

1	\$560	8	\$629
2	\$572	9	\$638
3	\$584	10	\$647
4	\$593	11	\$656
5	\$602	12	\$665
6	\$611	L	\$660
7	\$620		

OPEN MARKET

NOTES: Please reference pages 253-254 for additional specifications and mechanism information.

HON Recommendation: HSLVSMR.Y1.A.H.OS.CU__NL.SB.T - List Price \$655

HOW TO SPECIFY

Select Model Number	Select Control Type	Select Arm Type	Select Caster/Glide	Select Back Color	Select Fabric	Select Lumbar	Select Base	Select Frame
YO Synchro-Tilt Y1 Synchro-Tilt w/ Seat Slider (+ \$20)	N Armless F Fixed Arms (+ \$65) A Height and Width Adjustable Arms (+ \$75) V All-Adjustable Arms (includes pivot) (+ \$115)	H Hard Caster S Soft Caster (+ \$30) G Bell Glide (+ \$25) R Roll Control Caster (+ \$50)	OS Charcoal TI Titanium DW Designer White	See page 254	NL No Lumbar BL Black Adjustable Lumbar (+ \$30) BY Bullseye Adjustable Lumbar (+ \$30) DW Designer White Adjustable Lumbar (+ \$30) KT Krypton Adjustable Lumbar (+ \$30) MR Ember Adjustable Lumbar (+ \$30) RE Regatta Adjustable Lumbar (+ \$30) TL Titanium Adjustable Lumbar (+ \$30)	SB Standard Base	HSLVSMR Options T Black TI Titanium (+ \$35) HSLVSMRS Options DW Designer White (+ \$35) <i>Available for model HSLVSMRS only</i>	
H S L V S M R .	Y 1 .	A .	H .	O S .	C U 1 0 .	N L .	S B .	T



Icon Legend on page 15

HSLVTMU

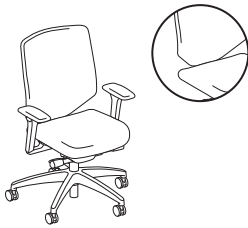

MID-BACK TASK

- Upholstered Back**
- Pneumatic
- Swivel
- Synchro-tilt
- Tilt Tension
- Tilt Lock

DIMENSIONS

- Seat Depth: 19¼
- Seat Width: 19
- Back Width: 18¼
- Back Height: 21½
- Arm Width: 17½-20
- Cube: 10.8
- Weight Rating: 300 lbs.

FABRIC PRICE CODES

- | | | | |
|---|-------|----|-------|
| 1 | \$519 | 8 | \$588 |
| 2 | \$531 | 9 | \$597 |
| 3 | \$543 | 10 | \$606 |
| 4 | \$552 | 11 | \$615 |
| 5 | \$561 | 12 | \$624 |
| 6 | \$570 | L | \$619 |
| 7 | \$579 | | |

NOTES: Please reference pages 253-254 for additional specifications and mechanism information.

HSLVTMUS

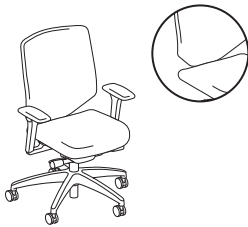

MID-BACK TASK IN DESIGNER WHITE

- Upholstered Back**
- Pneumatic
- Swivel
- Synchro-tilt
- Tilt Tension
- Tilt Lock

DIMENSIONS

- Seat Depth: 19¼
- Seat Width: 19
- Back Width: 18¼
- Back Height: 21½
- Arm Width: 17½-20
- Cube: 10.8
- Weight Rating: 300 lbs.

FABRIC PRICE CODES

- | | | | |
|---|-------|----|-------|
| 1 | \$519 | 8 | \$588 |
| 2 | \$531 | 9 | \$597 |
| 3 | \$543 | 10 | \$606 |
| 4 | \$552 | 11 | \$615 |
| 5 | \$561 | 12 | \$624 |
| 6 | \$570 | L | \$619 |
| 7 | \$579 | | |

OPEN MARKET

NOTES: Please reference pages 253-254 for additional specifications and mechanism information.

HON Recommendation: HSLVTMU.Y1.A.H.OS.COMF10.COMP10.NL.SB.T - List Price \$614

HOW TO SPECIFY

Select Model Number	Select Control Type	Select Arm Type	Select Caster/Glide	Select Back Color	Select Back Fabric	Select Seat Fabric	Select Lumbar	Select Base	Select Frame
	Y0 Synchro-Tilt Y1 Synchro-Tilt w/ Seat Slider (+ \$20) Y2 Advanced Synchro-Tilt (+ \$65)	HSLVTMU Options N Armless F Fixed Arms (+ \$65) A Height and Width Adjustable Arms (+ \$75) V All-Adjustable Arms (includes pivot) (+ \$115)	H Hard Caster S Soft Caster (+ \$30) G Bell Glide (+ \$25) R Roll Control Caster (+ \$50)	OS Charcoal TI Titanium DW Designer White	COMF46 Bittersweet COMF10 Ink COMF82 Meadow COMF90 Midnight COMF22 Putty COMF19 Sterling	See page 254	NL No Lumbar BL Black Adjustable Lumbar (+ \$30) BY Bullseye Adjustable Lumbar (+ \$30) DW Designer White Adjustable Lumbar (+ \$30) KT Krypton Adjustable Lumbar (+ \$30) MR Ember Adjustable Lumbar (+ \$30) RE Regatta Adjustable Lumbar (+ \$30) TL Titanium Adjustable Lumbar (+ \$30)	SB Standard Base	HSLVTMU Options T Black TI Titanium (+ \$35)
		HSLVTMUS Options ADW Height and Width Adjustable Arms (+ \$75) <i>Available for model HSLVTMUS only</i>							HSLVTMUS Options DW Designer White (+ \$35) <i>Available for model HSLVTMUS only</i>

H S L V T M U . Y 1 . A . H . O S . C O M F 1 0 . C O M P 1 0 . N L . S B . T

HSLVSMU

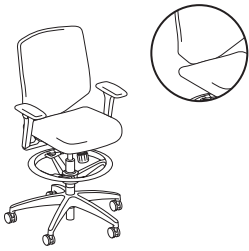

STOOL

Upholstered Back
Pneumatic
Swivel
Synchro-tilt
Tilt Tension
Tilt Lock

DIMENSIONS

Seat Depth: 19¼ Arm Width: 17½-20
Seat Width: 19 Cube: 10.8
Back Width: 18¼ Weight Rating: 300 lbs.
Back Height: 21½

FABRIC PRICE CODES

1	\$577	8	\$646
2	\$589	9	\$655
3	\$601	10	\$664
4	\$610	11	\$673
5	\$619	12	\$682
6	\$628	L	\$677
7	\$637		

NOTES: Please reference pages 253-254 for additional specifications and mechanism information.

HSLVSMUS

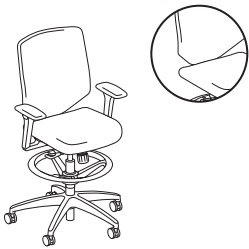

STOOL IN DESIGNER WHITE

Upholstered Back
Pneumatic
Swivel
Synchro-tilt
Tilt Tension
Tilt Lock

DIMENSIONS

Seat Depth: 19¼ Arm Width: 17½-20
Seat Width: 19 Cube: 10.8
Back Width: 18¼ Weight Rating: 300 lbs.
Back Height: 21½

FABRIC PRICE CODES

1	\$577	8	\$646
2	\$589	9	\$655
3	\$601	10	\$664
4	\$610	11	\$673
5	\$619	12	\$682
6	\$628	L	\$677
7	\$637		

OPEN MARKET

NOTES: Please reference pages 253-254 for additional specifications and mechanism information.

HON Recommendation: HSLVSMU.Y1.A.H.OS.COMF10.COMP10.NL.SB.T - List Price \$672

HOW TO SPECIFY

Select Model Number	Select Control Type	Select Arm Type	Select Caster/Glide	Select Back Color	Select Back Fabric	Select Seat Fabric	Select Lumbar	Select Base	Select Frame
	Y0 Synchro-Tilt Y1 Synchro-Tilt w/ Seat Slider (+\$20)	HSLVSMU Options N Armless F Fixed Arms (+\$65) A Height and Width Adjustable Arms (+\$75) V All-Adjustable Arms (includes pivot) (+\$115)	H Hard Caster S Soft Caster (+\$30) G Bell Glide (+\$25) R Roll Control Caster (+\$50)	OS Charcoal TI Titanium DW Designer White	COMF46 Bittersweet COMF10 Ink COMF82 Meadow COMF90 Midnight COMF22 Putty COMF19 Sterling	See page 254	NL No Lumbar BL Black Adjustable Lumbar (+\$30) BY Bullseye Adjustable Lumbar (+\$30) DW Designer White Adjustable Lumbar (+\$30) KT Krypton Adjustable Lumbar (+\$30) MR Ember Adjustable Lumbar (+\$30) RE Regatta Adjustable Lumbar (+\$30) TL Titanium Adjustable Lumbar (+\$30)	SB Standard Base	HSLVSMU Options T Black TI Titanium (+\$35)
		HSLVSMUS Options ADW Height and Width Adjustable Arms (+\$75) <i>Available for model HSLVSMUS only</i>							HSLVSMUS Options DW Designer White (+\$35) <i>Available for model HSLVSMUS only</i>
H S L V S M U	Y 1	A	H	O S	C O M F 1 0	C O M P 1 0	N L	S B	T



HSLVTMMKD

MID-BACK TASK

DIMENSIONS

FABRIC PRICE CODES

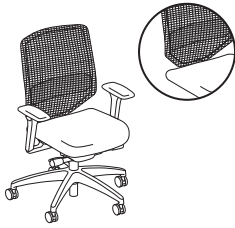

- 4-Way Stretch Back**
- Pneumatic
- Swivel
- Synchro-tilt
- Tilt Tension
- Tilt Lock

- Seat Depth: 19¼
- Seat Width: 19
- Back Width: 18¼
- Back Height: 21½
- Arm Width: 17½-20
- Cube: 5.6
- Weight Rating: 300 lbs.

- 1 \$432**
- 2 \$444**
- 3 \$456**

NOTES: Please reference pages 253-254 for additional specifications and mechanism information.

HSLVTMRKD

MID-BACK TASK

DIMENSIONS

FABRIC PRICE CODES

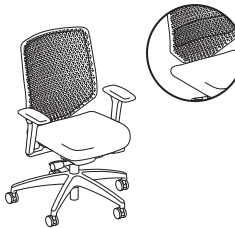

- ReActiv® Back**
- Pneumatic
- Swivel
- Synchro-tilt
- Tilt Tension
- Tilt Lock

- Seat Depth: 19¼
- Seat Width: 19
- Back Width: 18¼
- Back Height: 21½
- Arm Width: 17½-20
- Cube: 5.6
- Weight Rating: 300 lbs.

- 1 \$464**
- 2 \$476**
- 3 \$488**

NOTES: Please reference pages 253-254 for additional specifications and mechanism information.

HSLVTMUKD

MID-BACK TASK

DIMENSIONS

FABRIC PRICE CODES

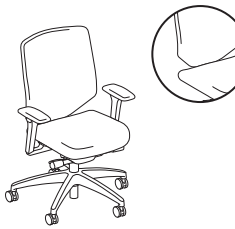

- Upholstered Back**
- Pneumatic
- Swivel
- Synchro-tilt
- Tilt Tension
- Tilt Lock

- Seat Depth: 19¼
- Seat Width: 19
- Back Width: 18¼
- Back Height: 21½
- Arm Width: 17½-20
- Cube: 5.6
- Weight Rating: 300 lbs.

- 1 \$479**
- 2 \$491**
- 3 \$503**

NOTES: Please reference pages 253-254 for additional specifications and mechanism information.

HON Recommendation: HSLVTMMKD.Y1.A.H.IM.CU__BL.SB.T - List Price \$557

HOW TO SPECIFY

Select Model Number	Select Control Type	Select Arm Type	Select Caster	Select Mesh Back	Select Back Color	Select Back Fabric	Select Seat Fabric	Select Lumbar	Select Base	Select Frame
	Y1 Synchro-Tilt w/ Seat Slider (+ \$20)	A Height and Width Adjustable Arms (+ \$75)	H Hard Caster	4-Way Stretch options IM Black <i>Specify for model HSLVTMMKD only</i>	OS Charcoal TI Titanium <i>Specify for models HSLVTMRKD and HSLVTMUKD only</i>	COMF46 Bittersweet COMF10 Ink COMF82 Meadow COMF90 Midnight COMF22 Putty COMF19 Sterling <i>Specify for model HSLVTMUKD only</i>	See page 254	NL No Lumbar BL Black Adjustable Lumbar (+ \$30)	SB Standard Base	T Black
HSLVTMMKD	Y1	A	H	IM			CU10	BL	SB	T
HSLVTMRKD	Y1	A	H		OS		CU10	BL	SB	T
HSLVTMUKD	Y1	A	H		OS	COMF46	CU10	BL	SB	T



HSLVLMBR

LUMBAR PACK

DIMENSIONS

LIST PRICE

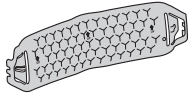

Ship Weight: 1 **Ⓢ**
Cube: 0.2

\$33

HOW TO SPECIFY

Select Model Number

Select Color

- BY** Bullseye Adjustable Lumbar
- DW** Designer White Adjustable Lumbar
- KT** Krypton Adjustable Lumbar
- MR** Ember Adjustable Lumbar
- RE** Regatta Adjustable Lumbar
- T** Black
- TI** Titanium

H S L V L M B R . T

HSLVFAP

FIXED ARM PACK

DIMENSIONS

LIST PRICE



Ship Weight: 6 **Ⓢ**
Cube: 1.0

\$112

HSLV2DAP

ADJUSTABLE ARM PACK

DIMENSIONS

LIST PRICE



Height and Width

Adjustable Arms Width: 17½-20
Height from Seat: 7¼-11¼
Ship Weight: 6 **Ⓢ**
Cube: 1.0

\$122

HSLV4DAP

ALL-ADJUSTABLE ARM PACK

DIMENSIONS

LIST PRICE



Including Pivot

Ship Weight: 6 **Ⓢ**
Cube: 1.0

\$164

HSCASTER

SET OF 5 SOFT CASTERS

DIMENSIONS

LIST PRICE

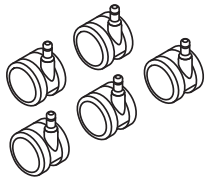

Size: 60mm
Ship Weight: 2 **Ⓢ**
Cube: 0.1

\$50

! Available in Black finish only, no specification needed.

HOW TO SPECIFY

Select Model Number

Select Color

- T** Black
- TI** Titanium
- DW** Designer White (available on HSLV2DAP only)

H S L V 2 D A P . T

SOOTHE®



Soothe Guest
Chairs and Tables.

SOOTHE®

Soothe offers the comfort and versatility to support a variety of healthcare and waiting environments. This family of patient and guest seats are constructed from durable materials and thoughtfully designed to be easily cleaned. The entire collection maximizes comfort along the patient's journey to recovery, enhances functionality for the caregiver, and creates the versatility required to deliver a higher level of care. Soothe simply helps create happier patients and better caregivers.



FEATURES

- Select Charcoal Urethane or solid hardwood arms in one of eight finishes.
- Wipeout space at the back of the seat allows for easy maintenance.
- Model HHCP1 has a responsive design back that moves with the patient for added comfort.
- Bench seating is available in two-seat or three-seat options.
- Choose Textured Charcoal or Textured Satin Chrome frame.
- Dual fabric option offers endless color combinations.
- Chairs can be ganged together to create straight rows.
- Warranted for users up to 350 lbs. (Model HHCG50 bariatric chair warranted for 750 lbs.)

SOOTHE[®] Options

MODEL OPTIONS

HHCG11
HHCG11DF - Dual Fabric



Guest Chair

HHCG21
HHCG21DF - Dual Fabric

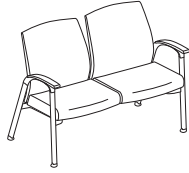

Two-Seat Chair

HHCG50
HHCG50DF - Dual Fabric

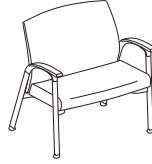

Bariatric Chair

HHCP1
HHCP1DF - Dual Fabric

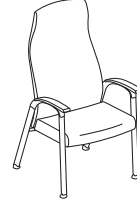

High-Back Patient Chair

HHCGB21

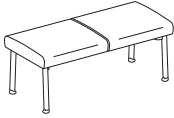

Two-Seat Bench

HHCGB31

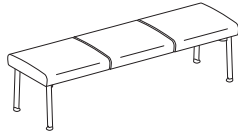

Three-Seat Bench

FINISH	CODE	DESCRIPTION	PRICE	FRAME	CODE	DESCRIPTION	PRICE
	S	Charcoal Urethane	+\$0		Grade P1		
	H	Bourbon Cherry	+\$100		P6P	Textured Black Mica	+\$0
	F	Shaker Cherry	+\$100		PK7	Textured Designer White	+\$0
	C	Harvest	+\$100		P7A	Textured Charcoal	+\$0
	D	Natural Maple	+\$100		P7J	Textured Brownstone	+\$0
	N	Mahogany	+\$100		P7L	Textured Loft	+\$0
	MOCH	Mocha	+\$100		P7M	Textured Muslin	+\$0
	COGN	Cognac	+\$100		P8V	Textured Titanium	+\$0
	PINC	Pinnacle	+\$100		Grade P2		
	LKI1	Kingswood Walnut	+\$100		PR8	Textured Silver	+\$0
	LFW1	Florence Walnut	+\$100				

HON BRANDED FABRICS

GRADE 1

Attire
Centurion
Compass
Contourett Polyurethane
Dapper
Hamilton
Inertia
Optic

GRADE 2

Appoint Seating
Clyde
Dotty
Rush
Seed
Spin Seating
Whisper Vinyl

GRADE 3

In Season
Purl
Silvertex™ Vinyl

For a complete list of fabrics, including partnership fabrics, go to hon.com/fabricsandfinishes.

Reference Fabric Color Combinations on pages 18-22 for color codes and legend on page 19 for lead times. For Fire Code and Moisture Barrier model availability and ordering method, refer to pages 26-29. For additional HON to Supply COM fabric grade pricing, go to honready.hon.com and click on the HON to Supply COM link.

 For Fire Code model, availability and ordering method, refer to pages 26-29. Available on select models, contact HON Customer Support for availability.

DUAL FABRIC COM YARDAGE

Due to fabric pattern nesting and potential reduction of fabric yield, some dual fabric models may require more total yardage than standard models.

	SEAT	BACK
HHCG11DF	1.4 yd	1.5 yd
HHCG21DF	1.7 yd	2.3 yd
HHCG50DF	1.4 yd	2.3 yd
HHCP1DF	1.4 yd	1.9 yd

SOOTHE[®]

Table Finish Options

AVAILABLE FINISHES

Soothe[®] Tables are available in 13 laminate colors. Each laminate has a specific selection of edges available.

LAMINATE TOP COLORS	EDGE BAND COLORS
Designer White (LDW1)	Designer White (DW)
Charcoal (S)	Charcoal (S)
Silver Mesh (B9)	Loft (LOFT)
Bourbon Cherry (H)	Bourbon Cherry (H), Muslin (T), White (WHIT)
Mahogany (N)	Mahogany (N), Loft (LOFT), Shadow (SHDW)
Natural Maple (D)	Natural Maple (D), Muslin (T), White (WHIT), Loft (LOFT)
Shaker Cherry (F)	Shaker Cherry (F), Muslin (T), White (WHIT), Loft (LOFT), Shadow (SHDW)
Harvest (C)	Harvest (C), Muslin (T), White (WHIT), Loft (LOFT)
Cognac (COGN)	Cognac (COGN), Muslin (T), White (WHIT)
Mocha (MOCH)	Mocha (MOCH), Muslin (T), White (WHIT), Loft (LOFT), Shadow (SHDW)
Pinnacle (PINC)	Pinnacle (PINC), Muslin (T), White (WHIT), Loft (LOFT), Shadow (SHDW)
Florence Walnut (LFW1)	Florence Walnut (FW)
Kingswood Walnut (LK11)	Kingswood Walnut (KI)



Icon Legend on page 15

HHCG11

GUEST CHAIR



DIMENSIONS

Depth:	27	Arm Width:	20½
Width:	25½	Seat to Floor Height:	18⅞
Height:	35	Usable Seat Depth:	18
Seat Depth:	18	Ship Weight:	55
Seat Width:	21½	Cube:	14.9
Back Width:	21	COM:	2.0
Back Height:	20½	Weight Rating:	350 lbs.

FABRIC PRICE CODES

1	\$1020	8	\$1296
2	\$1020	9	\$1332
3	\$1116	10	\$1368
4	\$1152	11	\$1404
5	\$1188	12	\$1440
6	\$1224	L	—
7	\$1260		

HHCG21

TWO-SEAT CHAIR

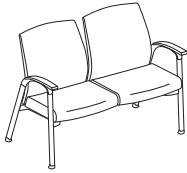

Outside Arms

DIMENSIONS

Depth:	27	Arm Width:	42¾
Width:	48	Seat to Floor Height:	18⅞
Height:	35	Usable Seat Depth:	18
Each Seat Depth:	18	Ship Weight:	109
Each Seat Width:	21½	Cube:	33.8
Each Back Width:	21	COM:	3.4
Each Back Height:	20¼	Weight Rating:	350 lbs.

FABRIC PRICE CODES

1	\$1688	8	\$2171
2	\$1772	9	\$2234
3	\$1856	10	\$2297
4	\$1919	11	\$2360
5	\$1982	12	\$2423
6	\$2045	L	—
7	\$2108		

HHCG50

BARIATRIC CHAIR



DIMENSIONS

Depth:	26	Arm Width:	29½
Width:	34½	Seat to Floor Height:	18⅞
Height:	35	Usable Seat Depth:	18
Seat Depth:	18	Ship Weight:	80
Seat Width:	30½	Cube:	25.1
Back Width:	30	COM:	3.0
Back Height:	20½	Weight Rating:	750 lbs.

FABRIC PRICE CODES

1	\$1282	8	\$1765
2	\$1366	9	\$1828
3	\$1450	10	\$1891
4	\$1513	11	\$1954
5	\$1576	12	\$2017
6	\$1639	L	—
7	\$1702		

! HHCG50 is a Single Seat Bariatric chair warranted to 750 lbs.

HHCP1

HIGH-BACK PATIENT CHAIR

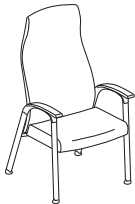

DIMENSIONS

Depth:	27	Arm Width:	20½
Width:	25½	Seat to Floor Height:	18⅞
Height:	46½	Usable Seat Depth:	18
Seat Depth:	18	Ship Weight:	61
Seat Width:	21½	Cube:	19.1
Back Width:	21	COM:	2.4
Back Height:	32	Weight Rating:	350 lbs.

FABRIC PRICE CODES

1	\$1137	8	\$1620
2	\$1221	9	\$1683
3	\$1305	10	\$1746
4	\$1368	11	\$1809
5	\$1431	12	\$1872
6	\$1494	L	—
7	\$1557		

! Only available in Silvertex and In Season under HON's Standard Fabric. Healthcare Grade Partnership Fabrics are available. For a complete list, please visit the Fabrics and Finishes page at HON.com.

OPEN MARKET

HOW TO SPECIFY

Select Model Number HHCG11	Select Finish S Charcoal Urethane H Bourbon Cherry (+ \$100) F Shaker Cherry (+ \$100) C Harvest (+ \$100) D Natural Maple (+ \$100) N Mahogany (+ \$100) MOCH Mocha (+ \$100) COGN Cognac (+ \$100) PINC Pinnacle (+ \$100) LK11 Kingswood Walnut (+ \$100) LFW1 Florence Walnut (+ \$100)	Select Fabric See page 265	Select Frame See page 265
H H C G 1 1	S	A I 9 0	P R 8

SOOTHE® Dual Fabric

GSA SIN 33721



Icon Legend on page 15

HHCG11DF



GUEST CHAIR

Dual Fabric

DIMENSIONS

Depth:	27	Arm Width:	20½
Width:	25½	Seat to Floor Height:	18⅞
Height:	35	Usable Seat Depth:	18
Seat Depth:	18	Ship Weight:	55
Seat Width:	21½	Cube:	14.9
Back Width:	21	COM:	See page 265
Back Height:	20½	Weight Rating:	350 lbs.

FABRIC PRICE CODES

1 \$1101

Add to Base Price Above

	Back	Seat
2	\$24	\$24
3	\$48	\$48
4	\$66	\$66
5	\$84	\$84
6	\$102	\$102
7	\$120	\$120
8	\$138	\$138
9	\$156	\$156
10	\$174	\$174
11	\$192	\$192
12	\$210	\$210

NOTES: For dual fabric models, start with the base price, then add the additional amount for the back and seat from the corresponding matrix to determine final price. Choose any combination of fabric grades for back and seat. See examples below:
HHCG11DF base price (\$1101) + Grade 2 back fabric (add \$24) + Grade 4 seat fabric (add \$66) = Total \$1191 List

HHCG21DF

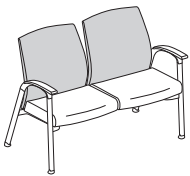

TWO-SEAT CHAIR

Dual Fabric
Outside Arms

DIMENSIONS

Depth:	27	Arm Width:	42¾
Width:	48	Seat to Floor Height:	18⅞
Height:	35	Usable Seat Depth:	18
Each Seat Depth:	18	Ship Weight:	109
Each Seat Width:	21½	Cube:	33.8
Each Back Width:	21	COM:	See page 265
Each Back Height:	20¼	Weight Rating:	350 lbs.

FABRIC PRICE CODES

1 \$1767

Add to Base Price Above

	Back	Seat
2	\$48	\$36
3	\$96	\$72
4	\$132	\$99
5	\$168	\$126
6	\$203	\$154
7	\$239	\$181
8	\$275	\$208
9	\$311	\$235
10	\$347	\$262
11	\$383	\$289
12	\$419	\$316

NOTES: For dual fabric models, start with the base price, then add the additional amount for the back and seat from the corresponding matrix to determine final price. Choose any combination of fabric grades for back and seat. See examples below:
HHCG21DF base price (\$1767) + Grade 2 back fabric (add \$48) + Grade 4 seat fabric (add \$99) = Total \$1914 List

HOW TO SPECIFY

<p>Select Model Number</p>	<p>Select Finish</p> <p>S Charcoal Urethane H Bourbon Cherry (+ \$100) F Shaker Cherry (+ \$100) C Harvest (+ \$100) D Natural Maple (+ \$100) N Mahogany (+ \$100) MOCH Mocha (+ \$100) COGN Cognac (+ \$100) PINC Pinnacle (+ \$100) LK11 Kingswood Walnut (+ \$100) LFW1 Florence Walnut (+ \$100)</p>	<p>Select Back Fabric</p> <p>See page 265</p>	<p>Select Seat Fabric</p> <p>See page 265</p>	<p>Select Frame</p> <p>See page 265</p>
<p>HHCG11DF .</p>	<p>S .</p>	<p>A190 .</p>	<p>RS14 .</p>	<p>PR8</p>



SOOTHE® Dual Fabric

HHCG50DF

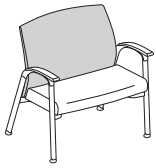

SIN 33721

BARIATRIC CHAIR

Dual Fabric

DIMENSIONS

Depth:	26	Arm Width:	29½
Width:	34½	Seat to Floor Height:	18⅝
Height:	35	Usable Seat Depth:	18
Seat Depth:	18	Ship Weight:	80
Seat Width:	30½	Cube:	25.1
Back Width:	30	COM:	See page 265
Back Height:	20½	Weight Rating:	750 lbs.

FABRIC PRICE CODES

1	\$1361	
<i>Add to Base Price Above</i>		
	Back	Seat
2	\$48	\$36
3	\$96	\$72
4	\$132	\$99
5	\$168	\$126
6	\$203	\$154
7	\$239	\$181
8	\$275	\$208
9	\$311	\$235
10	\$347	\$262
11	\$383	\$289
12	\$419	\$316

NOTES: For dual fabric models, start with the base price, then add the additional amount for the back and seat from the corresponding matrix to determine final price. Choose any combination of fabric grades for back and seat. See examples below:

HHCG50DF base price (\$1361) + Grade 2 back fabric (add \$48) + Grade 4 seat fabric (add \$99) = Total \$1508 List

! HHCG50DF is a Single Seat Bariatric chair warranted to 750 lbs.

HHCP1DF

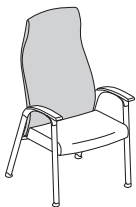

OPEN MARKET

HIGH-BACK PATIENT CHAIR

Dual Fabric

DIMENSIONS

Depth:	27	Arm Width:	20½
Width:	25½	Seat to Floor Height:	18⅝
Height:	46½	Usable Seat Depth:	18
Seat Depth:	18	Ship Weight:	61
Seat Width:	21½	Cube:	19.1
Back Width:	21	COM:	See page 265
Back Height:	32	Weight Rating:	350 lbs.

FABRIC PRICE CODES

1	\$1216	
<i>Add to Base Price Above</i>		
	Back	Seat
2	\$60	\$24
3	\$119	\$49
4	\$164	\$67
5	\$209	\$85
6	\$253	\$104
7	\$298	\$122
8	\$343	\$140
9	\$388	\$158
10	\$432	\$177
11	\$477	\$195
12	\$522	\$213

NOTES: For dual fabric models, start with the base price, then add the additional amount for the back and seat from the corresponding matrix to determine final price. Choose any combination of fabric grades for back and seat. See examples below:

HHCP1DF base price (\$1216) + Grade 2 back fabric (add \$60) + Grade 4 seat fabric (add \$67) = Total \$1343 List

! Only available in Silvertext and In Season under HON's Standard Fabric. Healthcare Grade Partnership Fabrics are available. For a complete list, please visit the Fabrics and Finishes page at HON.com.

HOW TO SPECIFY

Select Model Number HHCG50DF	Select Finish S Charcoal Urethane H Bourbon Cherry (+ \$100) F Shaker Cherry (+ \$100) C Harvest (+ \$100) D Natural Maple (+ \$100) N Mahogany (+ \$100) MOCH Mocha (+ \$100) COGN Cognac (+ \$100) PINC Pinnacle (+ \$100) LK11 Kingswood Walnut (+ \$100) LFW1 Florence Walnut (+ \$100)	Select Back Fabric See page 265	Select Seat Fabric See page 265	Select Frame See page 265
H H C G 5 0 D F	S	A I 9 0	R S 1 4	P R 8



HHCGB21

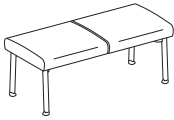

TWO-SEAT BENCH

DIMENSIONS

Depth:	20½	Seat to Floor Height:	17¾
Width:	44	Usable Seat Depth:	17¼
Height:	18¾	Ship Weight:	55
Seat Width:	22	Cube:	18.4
		COM:	1.9
		Weight Rating:	350 lbs.

FABRIC PRICE CODES

1	\$1223	8	\$1430
2	\$1259	9	\$1457
3	\$1295	10	\$1484
4	\$1322	11	\$1511
5	\$1349	12	\$1538
6	\$1376	L	—
7	\$1403		

ⓘ Benches cannot be ganged.

HHCGB31

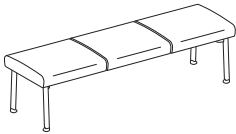

THREE-SEAT BENCH

DIMENSIONS

Depth:	20½	Seat to Floor Height:	17¾
Width:	66	Usable Seat Depth:	17¼
Height:	18¾	Ship Weight:	69
Seat Width:	22	Cube:	25.7
		COM:	2.6
		Weight Rating:	350 lbs.

FABRIC PRICE CODES

1	\$1573	8	\$1780
2	\$1609	9	\$1807
3	\$1645	10	\$1834
4	\$1672	11	\$1861
5	\$1699	12	\$1888
6	\$1726	L	—
7	\$1753		

ⓘ Benches cannot be ganged.

HOW TO SPECIFY

Select
Model Number

H H C G B 2 1 .

Select
Fabric

See page 265

R S 1 4 .

Select
Frame

See page 265

P R 8



HHCTS



IN-LINE TABLE TOP

DIMENSIONS

Depth:	22	Ship Weight:	8
Width:	16	Cube:	1.7
Height:	1½		

LIST PRICE

\$345

NOTES: Can be ganged between two chairs or freestanding.

HHCTC



90-DEGREE RADIUS CORNER TABLE TOP

DIMENSIONS

Depth:	29	Ship Weight:	15
Width:	29	Cube:	2.4
Height:	1½		

LIST PRICE

\$431

! Freestanding only.

HHCTRT



RECTANGLE TABLE TOP

DIMENSIONS

Depth:	22	Ship Weight:	20
Width:	40	Cube:	2.7
Height:	1½		

LIST PRICE

\$574

! Freestanding only.

HHCTL4

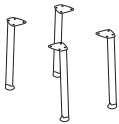

TABLE LEGS

Set of 4

DIMENSIONS

Ship Weight:	8
Cube:	0.4

LIST PRICE

\$231

NOTES: Can be attached to any of the table tops above to create a freestanding table.

HOW TO SPECIFY

<p>Select Model Number</p>	<p>Select Laminate and Edge</p> <p>See page 266</p>											
<table border="1"> <tr> <td>H</td><td>H</td><td>C</td><td>T</td><td>S</td><td>.</td> </tr> </table>	H	H	C	T	S	.	<table border="1"> <tr> <td>D</td><td>W</td><td>H</td><td>I</td><td>T</td> </tr> </table>	D	W	H	I	T
H	H	C	T	S	.							
D	W	H	I	T								

HOW TO SPECIFY

<p>Select Model Number</p>	<p>Select Paint Color</p> <p>See page 265</p>										
<table border="1"> <tr> <td>H</td><td>H</td><td>C</td><td>T</td><td>L</td><td>4</td><td>.</td> </tr> </table>	H	H	C	T	L	4	.	<table border="1"> <tr> <td>P</td><td>R</td><td>8</td> </tr> </table>	P	R	8
H	H	C	T	L	4	.					
P	R	8									



HHCGBRCH

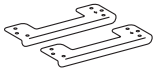

GANGING BRACKET

DIMENSIONS

Ship Weight: 2
Cube: 0.2

LIST PRICE

\$77

NOTES: For chair to chair connection. Does not connect a bench to other type of seating. Ganging brackets can be used with the seating models on pages 267-269. Bench models do not gang. Brackets are Charcoal only.

HHCGBR

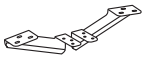

GANGING BRACKET

DIMENSIONS

Ship Weight: 5
Cube: 0.2

LIST PRICE

\$114

NOTES: For chair to table connection. Ganging brackets can be used with the seating models on pages 267-269. Bench models do not gang. Brackets are Charcoal only.

HOW TO SPECIFY

Select
Model Number

H H C G B R C H



HVL951



MID-BACK

360° Motion
Pneumatic
Swivel
Tilt
Functions: **A, E, F, K, L**
(Function Key on pages 16-17)

DIMENSIONS

Depth:	25 ⁵ / ₈	Seat to Floor Height:	17 ⁷ / ₈ -21 ¹ / ₂
Width:	26 ¹ / ₄	Usable Seat Depth:	18 ¹ / ₈
Height:	39 ³ / ₄	Ship Weight:	36 Ⓢ
Seat Depth:	18 ⁷ / ₈	Cube:	5.3
Seat Width:	19 ¹ / ₈	Weight Rating:	250 lbs.
Back Width:	18 ¹ / ₄		

PRICE CODE

Fabric **\$563**

NOTES: Model HVL951 is a mesh-back task chair with an active pivoting 5-star base. Armless. Chrome base cap. Black frame. **HON 5-Year Limited Warranty.**

HON Recommendation: HVL951.ES10.T - List Price \$563

HOW TO SPECIFY

Select
Model Number

H V L 9 5 1 .

Select
Fabric

ES10 Black

E S 1 0 .

Select
Frame

T Black

T

TOPFLIGHT™ Wood Seating

OPEN MARKET



Icon Legend on page 15

HVL844



HIGH-BACK

Pneumatic
Swivel
Tilt
Tilt Tension
Tilt Lock
Fixed Padded Wood Arms and Base

Functions: **A, E, F, K, L**
(Function Key on pages 16-17)

DIMENSIONS

Depth:	30	Arm Width:	20¼
Width:	28	Seat to Floor Height:	17 ³ / ₁₆ -21 ¹ / ₁₆
Height:	47 ⁵ / ₁₆	Usable Seat Depth:	17½
Seat Depth:	18½	Ship Weight:	58 Ⓢ
Seat Width:	20½	Cube:	6.4
Back Width:	20½	Weight Rating:	250 lbs.
Back Height:	27½		

PRICE CODE

Leather **\$675**

NOTES: Wood accents available in Mahogany. High-back design. SofThread™ Leather. Tailored padded back design provides strong lumbar support. Fixed padded loop arms. Use with coordinated Guest Chair models HVL852 and HVL853 shown below. **HON 5-Year Limited Warranty.**

HON Recommendation: HVL844.N.SB11 - List Price \$675

HVL852



GUEST CHAIR

Leg Base
Arms
Upholstered Back
Wood Frame

DIMENSIONS

Depth:	22	Arm Width:	20
Width:	22½	Seat to Floor Height:	18½
Height:	31	Usable Seat Depth:	17
Seat Depth:	17	Ship Weight:	26 Ⓢ
Seat Width:	20	Cube:	3.4
Back Width:	20	Weight Rating:	250 lbs.
Back Height:	13		

PRICE CODE

Leather **\$422**

NOTES: Wood frames available in Mahogany. Black SofThread™ Leather inset in back and on seat. Black SofThread™ Leather. Easier assembly – seat now attached to frame. Use with coordinating Executive model HVL844 shown above. **HON 5-Year Limited Warranty.**

HON Recommendation: HVL852.N.SB11 - List Price \$422

HVL853

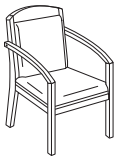

GUEST CHAIR

Leg Base
Arms
Upholstered Back
Wood Frame

DIMENSIONS

Depth:	23¾	Arm Width:	20¼
Width:	23⅝	Seat to Floor Height:	19½
Height:	36⅝	Usable Seat Depth:	18¼
Seat Depth:	18¼	Ship Weight:	35 Ⓢ
Seat Width:	22	Cube:	6.9
Back Width:	18½	Weight Rating:	250 lbs.
Back Height:	15¼		

PRICE CODE

Leather **\$512**

NOTES: Wood frames available in Mahogany. Black SofThread™ Leather on fully-upholstered back panel and on seat. High-back design. Use with coordinating Executive model HVL844 shown above. **HON 5-Year Limited Warranty.**

HON Recommendation: HVL853.N.SB11 - List Price \$512

HOW TO SPECIFY

<p>Select Model Number</p> <p>H V L 8 4 4 .</p>	<p>Select Wood Finish</p> <p>N Mahogany</p> <p>N .</p>	<p>Select Fabric</p> <p>SB11 Black SofThread™ Leather</p> <p>S B 1 1</p>
--	---	---



TORCH™ Mesh Chairs

HVL511



MID-BACK

Pneumatic
Swivel
Tilt
Tilt Tension
Tilt Lock
Fixed Arms

Functions: **A, E, F, K, L**
(Function Key on pages 16-17)

DIMENSIONS

Depth:	26	Arm Width:	18¾
Width:	26	Seat to Floor Height:	16⅞-20⅝
Height:	40½	Usable Seat Depth:	18¾
Seat Depth:	18¼	Ship Weight:	30 Ⓢ
Seat Width:	19½	Cube:	3.8
Back Width:	17¾	Weight Rating:	250 lbs.
Back Height:	21¾		

PRICE CODE

Fabric **\$282**

NOTES: Mid-back Mesh chair. Comfortable and breathable mesh back. Black fabric seat. Black frame. Fixed arms. **HON 5-Year Limited Warranty.**

HON Recommendation: HVL511.LH10 - List Price \$282

HVL515

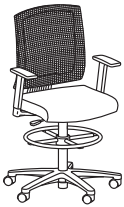

TASK STOOL

Pneumatic
Swivel
Fixed Arms

Functions: **A, E**
(Function Key on pages 16-17)

DIMENSIONS

Depth:	26	Arm Width:	18¾
Width:	26	Seat to Floor Height:	23⅞-33
Height:	52	Usable Seat Depth:	18¾
Seat Depth:	18¼	Ship Weight:	38 Ⓢ
Seat Width:	19½	Cube:	4.6
Back Width:	17¾	Weight Rating:	250 lbs.
Back Height:	21¾		

PRICE CODE

Fabric **\$393**

NOTES: Comfortable and breathable mesh back. Black fabric seat. Fixed arms. **HON 5-Year Limited Warranty.**

HON Recommendation: HVL515.LH10 - List Price \$393

HOW TO SPECIFY

Select Model Number	Select Fabric
	LH10 Black Fabric
H V L 5 1 1 .	L H 1 0

TRACTION™ Executive Chairs

OPEN MARKET



Icon Legend on page 15

HVL103



HIGH-BACK

Pneumatic
Swivel
Tilt
Tilt Tension
Tilt Lock
Fixed Padded Arms

Functions: **A, E, F, K, L**
(Function Key on pages 16-17)

DIMENSIONS

Depth:	28 ³ / ₄	Arm Width:	18 ⁷ / ₈
Width:	26 ³ / ₄	Seat to Floor Height:	17 ¹ / ₄ -21
Height:	42 ¹ / ₂	Usable Seat Depth:	18 ³ / ₄
Seat Depth:	18 ¹ / ₄	Ship Weight:	36.0 Ⓢ
Seat Width:	19 ¹ / ₂	Cube:	4.1
Back Width:	19 ¹ / ₂	Weight Rating:	250 lbs.
Back Height:	24 ⁷ / ₈		

PRICE CODE

Leather \$435

NOTES: Black SofThread™ Leather. Red SofThread™ and White SofThread™ Leather options. Polished base. Fixed, padded arms. **HON 5-Year Limited Warranty.**

HON Recommendation: HVL103.SB11 - List Price \$435

HVL102



HIGH-BACK MODERN GUEST CHAIR

Padded Arms
Cantilever Base

DIMENSIONS

Depth:	27 ¹¹ / ₆₄	Arm Width:	18 ⁴⁵ / ₆₄
Width:	20 ⁵ / ₆₄	Seat to Floor Height:	18 ²⁹ / ₃₂
Height:	39 ³ / ₈	Usable Seat Depth:	18 ⁷ / ₆₄
Seat Depth:	18 ⁷ / ₆₄	Ship Weight:	36.8 Ⓢ
Seat Width:	19 ¹¹ / ₁₆	Cube:	4.4
Back Width:	18 ²⁹ / ₃₂	Weight Rating:	250 lbs.
Back Height:	24 ³⁹ / ₆₄		

PRICE CODE

Leather \$326

NOTES: Black SofThread™ Leather. Polished, cantilever base. Polished, padded arms. **HON 5-Year Limited Warranty.**

HON Recommendation: HVL102.SB11 - List Price \$326

HOW TO SPECIFY

Select Model Number

H V L 1 0 3 .

Select Fabric

- SB11** Black SofThread™ Leather
Specify for models HVL102 and HVL103 only
- SB06** White SofThread™ Leather
Specify for model HVL103 only
- SB42** Red SofThread™ Leather
Specify for model HVL103 only

S B 1 1



HVL604



HIGH-BACK

Pneumatic
Swivel
Tilt
Tilt Tension
Tilt Lock
Fixed Arms

Functions: **A, E, F, K, L, T**
(Function Key on pages 16-17)

DIMENSIONS

Depth:	26½	Arm Width:	20½
Width:	25	Seat to Floor Height:	16¼-20¾
Height:	46½	Usable Seat Depth:	18¼
Seat Depth:	18¼	Ship Weight:	40 Ⓢ
Seat Width:	19¾	Cube:	4.1
Back Width:	20	Weight Rating:	250 lbs.
Back Height:	26½		

PRICE CODE

Leather \$279

NOTES: Available in Black SofThread™ Leather SB11. High-back Executive Chair. Black frame. Fixed, tapered loop arms. Coordinating guest chair HVL605. **HON 5-Year Limited Warranty.**

! Available in Black SofThread™ Leather SB11 only.

HON Recommendation: HVL604.SB11 - List Price \$279

HVL605



GUEST CHAIR

Leg Base
Arms
Stacks up to Four High

DIMENSIONS

Depth:	24	Arm Width:	19½
Width:	23½	Seat to Floor Height:	18½
Height:	34½	Usable Seat Depth:	17½
Seat Depth:	17½	Ship Weight:	22.2 Ⓢ
Seat Width:	18½	Cube:	3.0
Back Width:	18½	Weight Rating:	250 lbs.
Back Height:	17¾		

PRICE CODE

Leather \$267

NOTES: Validate™ HVL605 Guest Chair. Waterfall seat edge. Wall-saver design. Fixed arms. Stackable up to 4-high. Contemporary rectilinear steel frame in Matte Black. Use with coordinating Executive Chair model HVL604. **HON 5-Year Limited Warranty.**

HON Recommendation: HVL605.SB11 - List Price \$267

HVL685



HIGH-BACK

Pneumatic
Swivel
Tilt Tension
Tilt Lock
Fixed Padded Arms

Functions: **A, E, K, L**
(Function Key on pages 16-17)

DIMENSIONS

Depth:	32	Back Height:	28½
Width:	27½	Seat to Floor Height:	18¾-21¾
Height:	45	Usable Seat Depth:	20
Seat Depth:	20	Ship Weight:	67 Ⓢ
Seat Width:	22¼	Cube:	9.5
Back Width:	21	Weight Rating:	450 lbs.

PRICE CODE

Leather \$900

NOTES: Large scale model HVL685 will support up to 450 lbs with normal use. Available in Black SofThread™ Leather SB11. **HON 5-Year Limited Warranty.**

HON Recommendation: HVL685.SB11 - List Price \$900

HOW TO SPECIFY

Select Model Number	Select Fabric
	SB11 Black SofThread™ Leather
H V L 6 0 4 .	S B 1 1



HVL205



LOW-BACK

Pneumatic
Swivel
Tilt
Tilt Tension
Tilt Lock

DIMENSIONS

Depth:	23	Back Height:	18
Width:	23	Seat to Floor Height:	15¼-19¼
Height:	39½	Usable Seat Depth:	18
Seat Depth:	18	Ship Weight:	29 Ⓢ
Seat Width:	19	Cube:	3.2
Back Width:	18	Weight Rating:	250 lbs.

PRICE CODE

Mesh **\$243**

NOTES: Comfortable and breathable mesh back. Black Sandwich Mesh seat. Black frame. **HON 5-Year Limited Warranty.**

HON Recommendation: HVL205.MM10.T - List Price \$243

HVL210



TASK LOW-BACK

Pneumatic
Swivel
Tilt
Tilt Tension
Tilt Lock
Functions: **A, E, F, K, L**
(Function Key on pages 16-17)

DIMENSIONS

Depth:	33½	Back Height:	20¼
Width:	24½	Seat to Floor Height:	17-20½
Height:	38¼	Usable Seat Depth:	17¾
Seat Depth:	17¾	Ship Weight:	31 Ⓢ
Seat Width:	19¾	Cube:	3.6
Back Width:	19¾	Weight Rating:	250 lbs.

PRICE CODE

Sandwich Mesh **\$231**

NOTES: Black Sandwich Mesh. Sturdy textured black frame. HVL995 optional arm pack available. **HON 5-Year Limited Warranty.**

HON Recommendation: HVL210.MM10 - List Price \$231

HVL215



TASK STOOL

Pneumatic
Swivel
Functions: **A, E**
(Function Key on pages 16-17)

DIMENSIONS

Depth:	33½	Back Height:	19
Width:	24½	Seat to Floor Height:	24½-33½
Height:	51⅞	Usable Seat Depth:	17¾
Seat Depth:	17¾	Ship Weight:	37 Ⓢ
Seat Width:	19¾	Cube:	5.7
Back Width:	19¾	Weight Rating:	250 lbs.

PRICE CODE

Sandwich Mesh **\$322**

NOTES: Black Sandwich Mesh. Sturdy textured black frame. HVL995 optional arm pack available. **HON 5-Year Limited Warranty.**

HON Recommendation: HVL215.MM10 - List Price \$322

HVL995



HEIGHT-ADJUSTABLE ARMS

Functions: **Q**
(Function Key on pages 16-17)

DIMENSIONS

Adjustable Arms Width:	18¾
Height from Seat:	8-11
Ship Weight:	7 Ⓢ
Cube:	0.6

LIST PRICE

\$95

NOTES: Arm color is black. Height-adjustable. Compatible with HVL205, HVL210, and HVL215. **HON 5-Year Limited Warranty.**

HON Recommendation: HVL995 - List Price \$95

HOW TO SPECIFY

<p>Select Model Number</p> <p>H V L 2 0 5 .</p>	<p>Select Fabric</p> <p>MM10 Black Sandwich Mesh Fabric</p> <p>M M 1 0 .</p>	<p>Select Frame</p> <p>T Black Specify frame color for model HVL205 only</p> <p>T</p>
--	---	--

VERSANT® TANDEM



Versant® Bariatric Seating shown with Laminate End Table.

VERSANT® TANDEM

Everyone deserves a break from time to time, and a comfy seat in which to enjoy one. Bring stylish support to your welcome areas, public spaces and break rooms with Versant. With a combination of tandem seats and bariatric chairs, it's ideal for both healthcare environments and offices. Arched arms support the upper body and padded seats put people at ease for longer periods of time. Versant brings versatility to every corner of your space.



FEATURES

- Stylish arched arm offers greater upper body support.
- Seats are removable for easy cleaning and replacement.
- Contrasting covers are available as special order (please contact customer service).
- Solid hardwood in one of eight attractive finishes.
- Available in hundreds of quality HON fabrics.
- Warranted for users up to 350 lbs. (Model HHCB50 is warranted for users up to 500 lbs.)

VERSANT® Tandem Options

MODEL OPTIONS

HHB02



Two-Seat Bench

HHB03

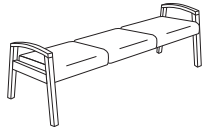

Three-Seat Bench

HHCT01

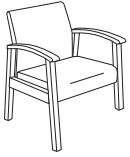

Single Seat

Leg Base, Arms

HHCT02

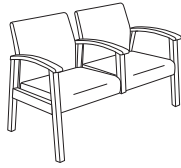

Two-Seat

Leg Base, Center Arm, Arms

HHCT12

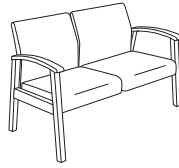

Two-Seat

Leg Base, Arms

HHCB50

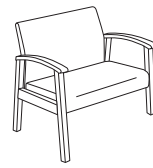

Bariatric Chair

Leg Base, Arms

AVAILABLE FINISHES

Versant® Tandem Seating is available in 8 wood finishes.

WOOD FINISHES

Bourbon Cherry (H)

Cognac (COGN)

Harvest (C)

Mahogany (N)

Mocha (MOCH)

Natural Maple (D)

Pinnacle (PINC)

Shaker Cherry (F)

HON BRANDED FABRICS

GRADE 1

Attire
Centurion
Contourett Polyurethane
Dapper
Hamilton
Inertia
Optic

GRADE 2

Appoint Seating
Clyde
Dotty
Rush
Seed
Spin Seating
Whisper Vinyl

GRADE 3

In Season
Purl
Silvertex™ Vinyl

For a complete list of fabrics, including partnership fabrics, go to hon.com/fabricsandfinishes.

Reference Fabric Color Combinations on pages 18-22 for color codes and legend on page 19 for lead times. Contrasting covers on seat and back are available as special order. Please contact Customer Service. For additional HON to Supply COM fabric grade pricing, go to honready.hon.com and click on the HON to Supply COM link.

 For Fire Code model, availability and ordering method, refer to pages 26-29. Available on select models, contact HON Customer Support for availability.

AVAILABLE LAMINATES

Versant® Tandem Laminate Occasional Tables are available in 8 laminates.

LAMINATES

Bourbon Cherry (H)

Cognac (COGN)

Harvest (C)

Mahogany (N)

Mocha (MOCH)

Natural Maple (D)

Pinnacle (PINC)

Shaker Cherry (F)



VERSANT® TANDEM

HHB02

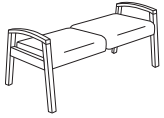

TWO-SEAT BENCH

DIMENSIONS

Depth:	20 ³ / ₈	Seat to Floor Height:	19 ¹ / ₂
Width:	45 ¹ / ₂	Usable Seat Depth:	19 ³ / ₄
Height:	23	Ship Weight:	62
Each Seat Depth:	20 ³ / ₈	Cube:	16.2
Each Seat Width:	21 ¹ / ₂	COM:	2.0
Arm Width:	42 ¹ / ₂	Weight Rating:	350 lbs. (per seat)

FABRIC PRICE CODES

1	\$1593	8	\$1869
2	\$1641	9	\$1905
3	\$1689	10	\$1941
4	\$1725	11	\$1977
5	\$1761	12	\$2013
6	\$1797	L	\$1993
7	\$1833		

HHB03

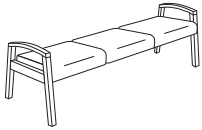

THREE-SEAT BENCH

DIMENSIONS

Depth:	20 ³ / ₈	Seat to Floor Height:	19 ¹ / ₂
Width:	66 ¹ / ₂	Usable Seat Depth:	19 ³ / ₄
Height:	23	Ship Weight:	80
Each Seat Depth:	20 ³ / ₈	Cube:	24.5
Each Seat Width:	21 ¹ / ₂	COM:	2.5
Arm Width:	63 ¹ / ₂	Weight Rating:	350 lbs. (per seat)

FABRIC PRICE CODES

1	\$2048	8	\$2393
2	\$2108	9	\$2438
3	\$2168	10	\$2483
4	\$2213	11	\$2528
5	\$2258	12	\$2573
6	\$2303	L	\$2548
7	\$2348		

HON Recommendation: HHB02.MOCH.SX__ - List Price \$1689

HOW TO SPECIFY

Select Model Number

HHB02

Select Finish

See page 281

MOCH

Select Seat Fabric

See page 281

SX05

VERSANT® TANDEM

Laminate Occasional Tables

OPEN MARKET



Icon Legend on page 15

HHCT048

COFFEE TABLE

DIMENSIONS

Length: 48 Ship Weight: 44 Ⓢ
 Width: 20 Cube: 3.0
 Height: 17

LIST PRICE

\$645

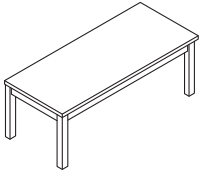

HHCT024

CORNER TABLE

DIMENSIONS

Length: 24 Ship Weight: 20 Ⓢ
 Width: 24 Cube: 1.4
 Height: 17

LIST PRICE

\$540

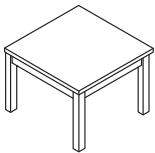

HHCT020

END TABLE

DIMENSIONS

Length: 24 Ship Weight: 22 Ⓢ
 Width: 20 Cube: 1.4
 Height: 17

LIST PRICE

\$507

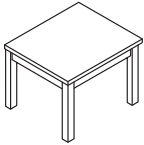

HON Recommendation: HHCT024.MOCH - List Price \$540

HOW TO SPECIFY

<p>Select Model Number</p>	<p>Select Laminate See page 282</p>
<p>HHCT048 .</p>	<p>MOCH</p>



VERSANT® TANDEM

HHCT01

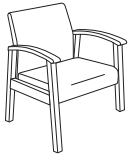

SINGLE SEAT

Leg Base
Arms

DIMENSIONS

Depth:	27	Arm Width:	20½
Width:	25	Seat to Floor Height:	18
Height:	34	Usable Seat Depth:	19¼
Seat Depth:	20¼	Ship Weight:	57
Seat Width:	21	Cube:	20.1
Back Width:	21	COM:	2.0
Back Height:	17	Weight Rating:	350 lbs.

FABRIC PRICE CODES

1	\$1215	8	\$1491
2	\$1263	9	\$1527
3	\$1311	10	\$1563
4	\$1347	11	\$1599
5	\$1383	12	\$1635
6	\$1419	L	\$1615
7	\$1455		

HHCT02

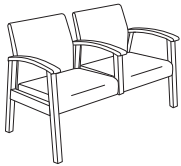

TWO-SEAT

Leg Base
Center Arm
Arms

DIMENSIONS

Depth:	27	Seat to Floor Height:	18
Width:	47½	Usable Seat Depth:	19¼
Height:	34	Ship Weight:	87
Each Seat Depth:	20¼	Cube:	33.7
Each Seat Width:	21	COM:	3.5
Each Back Width:	21	Weight Rating:	350 lbs.
Each Back Height:	17		(per seat)

FABRIC PRICE CODES

1	\$2122	8	\$2605
2	\$2206	9	\$2668
3	\$2290	10	\$2731
4	\$2353	11	\$2794
5	\$2416	12	\$2857
6	\$2479	L	\$2822
7	\$2542		

HHCT12

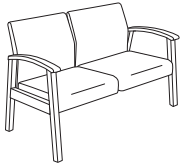

TWO-SEAT

Leg Base
Arms

DIMENSIONS

Depth:	27	Arm Width:	41½
Width:	46	Seat to Floor Height:	18
Height:	34	Usable Seat Depth:	19¼
Each Seat Depth:	20¼	Ship Weight:	87
Each Seat Width:	21	Cube:	33.0
Each Back Width:	21	COM:	3.5
Each Back Height:	17	Weight Rating:	350 lbs.
			(per seat)

FABRIC PRICE CODES

1	\$2030	8	\$2513
2	\$2114	9	\$2576
3	\$2198	10	\$2639
4	\$2261	11	\$2702
5	\$2324	12	\$2765
6	\$2387	L	\$2730
7	\$2450		

HHCB50

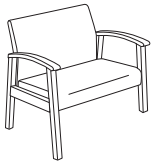

BARIATRIC SINGLE SEAT

Leg Base
Arms

DIMENSIONS

Depth:	27	Arm Width:	29
Width:	33½	Seat to Floor Height:	18
Height:	34	Usable Seat Depth:	19¼
Each Seat Depth:	20¼	Ship Weight:	80
Each Seat Width:	30	Cube:	29.0
Each Back Width:	30	COM:	3.0
Each Back Height:	17	Weight Rating:	500 lbs.

FABRIC PRICE CODES

1	\$1819	8	\$2233
2	\$1891	9	\$2287
3	\$1963	10	\$2341
4	\$2017	11	\$2395
5	\$2071	12	\$2449
6	\$2125	L	\$2419
7	\$2179		

HON Recommendation: HHCT01.MOCH.SX__ - List Price \$1311

HOW TO SPECIFY

<p>Select Model Number</p> <p>HHCT01</p>	<p>Select Finish</p> <p>See page 281</p> <p>MOCH</p>	<p>Select Seat Fabric</p> <p>See page 281</p> <p>SX05</p>
---	---	--



Volt® Task Chairs and Stools shown with Voi® Desks.

VOLT®

Customizable comfort, distinctive styling and an affordable price point make Volt the family of task seating that supports your body and your budget. The stylish V-shaped back design can be specified in fabric, leather or breathable mesh, giving you more control over your look and feel. The personalized controls and generously proportioned seat and back deliver greater comfort, and are designed support to a wider variety of users. Volt delivers the look you desire, the comfort you demand, and the quality you expect. That's the power of practicality.



FEATURES

- Optional synchro-tilt control provides a smooth, natural recline.
- Optional height-adjustable arms provide a custom fit.
- Optional mesh back offers breathable support.
- Task stools feature an adjustable footring for additional lower body support.
- One-touch seat height adjustment easily moves the seat up and down.
- Tilt tension controls the rate and ease of recline.
- Tilt lock allows the user to lock out the tilt function.
- 360-degree swivel provides freedom of movement in any direction.
- Select models available in hundreds of quality HON fabrics.
- Warranted for users up to 275 lbs.

VOLT® 5700/5710 Series Options

MODEL OPTIONS

H5701



Task Chair

Pneumatic, Swivel, Tilt, Tilt Tension, Tilt Lock

H5703



Task Chair

Pneumatic, Swivel, Synchro-tilt, Tilt Tension, Tilt Lock

H5705



Task Stool

Pneumatic, Swivel, Adjustable Footring

H5711



Task Chair (Mesh Back)

Pneumatic, Swivel, Tilt, Tilt Tension, Tilt Lock

H5713



Task Chair (Mesh Back)

Pneumatic, Swivel, Synchro-tilt, Tilt Tension, Tilt Lock

H5715



Task Stool (Mesh Back)

Pneumatic, Swivel, Adjustable Footring

HON BRANDED FABRICS

GRADE 1

Black Fabric
Crimson Fabric *
Navy Fabric

GRADE 2

GRADE 3

* Fabric is de-emphasized.

For a complete list of fabrics, including partnership fabrics, go to hon.com/fabricsandfinishes.

**Crimson and Navy only available on select models.

Reference Fabric Color Combinations on pages 18-22 for color codes and legend on page 19 for lead times.

⚠ For Fire Code model, availability and ordering method, refer to pages 26-29. Available on select models, contact HON Customer Support for availability.

VOLT® 5700 Series

OPEN MARKET



Icon Legend on page 15

H5701



TASK CHAIR

Pneumatic
Swivel
Tilt
Tilt Tension
Tilt Lock
Functions: **A, E, F, K, L**
(Function Key on pages 16-17)

DIMENSIONS

Depth:	25 ³ / ₄	Seat to Floor Height:	18-22 ¹ / ₄
Width:	26	Usable Seat Depth:	18 ³ / ₄
Height:	40	Ship Weight:	29 Ⓢ
Seat Depth:	18 ³ / ₄	Cube:	5.1
Seat Width:	18 ¹ / ₂	Weight Rating:	275 lbs.
Back Width:	17 ¹ / ₄		
Back Height:	18 ³ / ₄		

FABRIC PRICE CODES

1 \$292 L \$322

H5703



TASK CHAIR

Pneumatic
Swivel
Synchro-tilt
Tilt Tension
Tilt Lock
Functions: **A, E, J, K, L**
(Function Key on pages 16-17)

DIMENSIONS

Depth:	25 ³ / ₄	Seat to Floor Height:	18-22 ¹ / ₄
Width:	26	Usable Seat Depth:	18 ³ / ₄
Height:	40	Ship Weight:	29 Ⓢ
Seat Depth:	18 ³ / ₄	Cube:	5.1
Seat Width:	18 ¹ / ₂	Weight Rating:	275 lbs.
Back Width:	17 ¹ / ₄		
Back Height:	18 ³ / ₄		

FABRIC PRICE CODES

1 \$341 L \$371

H5705



TASK STOOL

Pneumatic
Swivel
Adjustable Footring
Functions: **A, E**
(Function Key on pages 16-17)

DIMENSIONS

Depth:	29 ¹ / ₂	Seat to Floor Height:	22 ⁷ / ₈ -32 ³ / ₈
Width:	27	Usable Seat Depth:	18
Height:	49 ⁷ / ₈	Ship Weight:	36 Ⓢ
Seat Depth:	20	Cube:	6.0
Seat Width:	19	Weight Rating:	275 lbs.
Back Width:	16 ¹ / ₂		
Back Height:	20		

FABRIC PRICE CODES

1 \$480 L \$510

H5795

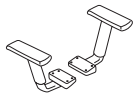

HEIGHT-ADJUSTABLE ARMS

Non-upholstered
Functions: **Q**
(Function Key on pages 16-17)

DIMENSIONS

Adjustable Arms Width:	17 ³ / ₈
Height from Seat:	7 ⁵ / ₈ -10 ⁵ / ₈
Ship Weight:	5 Ⓢ
Cube:	0.6

LIST PRICE

\$91

HON Recommendation: H5703.GA10.T with H5795 Arm Pack - List Price \$432

HOW TO SPECIFY

<p>Select Model Number</p> <p>H 5 7 0 3 .</p>	<p>Select Fabric</p> <p>SB11 Black Leather GA10 Black GA42 Crimson Ⓢ (only available on H5701) GA90 Navy (only available on H5701) Ⓢ Fabric is de-emphasized</p> <p>G A 1 0 .</p>	<p>Select Frame</p> <p>T Black</p> <p>T</p>
--	--	--



VOLT® 5710 Series

H5711



TASK CHAIR

Mesh Back
Pneumatic
Swivel
Tilt
Tilt Tension
Tilt Lock
Functions: **A, E, F, K, L**
(Function Key on pages 16-17)

DIMENSIONS

Depth: 25³/₄
Width: 26
Height: 38³/₄
Seat Depth: 18³/₄
Seat Width: 19¹/₄
Back Width: 18
Back Height: 18³/₄
Seat to Floor Height: 18³/₄-22³/₈
Usable Seat Depth: 18
Ship Weight: 29 **Ⓢ**
Cube: 5.1
COM: 1.5
Weight Rating: **275 lbs.**

FABRIC PRICE CODES

1 \$405 L \$435

H5713



TASK CHAIR

Mesh Back
Pneumatic
Swivel
Synchro-tilt
Tilt Tension
Tilt Lock
Functions: **A, E, J, K, L**
(Function Key on pages 16-17)

DIMENSIONS

Depth: 25³/₄
Width: 26
Height: 38¹/₂
Seat Depth: 18³/₄
Seat Width: 19¹/₄
Back Width: 18
Back Height: 18³/₄
Seat to Floor Height: 17³/₈-21¹/₈
Usable Seat Depth: 17⁷/₈
Ship Weight: 32 **Ⓢ**
Cube: 5.1
COM: 1.5
Weight Rating: **275 lbs.**

FABRIC PRICE CODES

1 \$455 L \$485

H5715



TASK STOOL

Mesh Back
Pneumatic
Swivel
Adjustable Footring
Functions: **A, E**
(Function Key on pages 16-17)

DIMENSIONS

Depth: 28
Width: 26
Height: 49⁷/₈
Seat Depth: 20
Seat Width: 19
Back Width: 18
Back Height: 18¹/₂
Seat to Floor Height: 22⁷/₈-32³/₈
Usable Seat Depth: 18
Ship Weight: 36 **Ⓢ**
Cube: 6.0
COM: 1.5
Weight Rating: **275 lbs.**

FABRIC PRICE CODES

1 \$597 L \$627

H5795

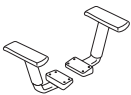

HEIGHT-ADJUSTABLE ARMS

Non-upholstered
Functions: **Q**
(Function Key on pages 16-17)

DIMENSIONS

Adjustable Arms Width: 17³/₈
Height from Seat: 7³/₈-10⁵/₈
Ship Weight: 5 **Ⓢ**
Cube: 0.6

LIST PRICE

\$91

HON Recommendation: H5713.GA10.T with H5795 Arm Pack - List Price \$546

HOW TO SPECIFY

<p>Select Model Number</p> <p>H 5 7 1 3</p>	<p>Select Fabric</p> <p>SB11 Black Leather GA10 Black</p> <p>G A 1 0</p>	<p>Select Frame</p> <p>T Black</p> <p>T</p>
--	---	---

VOLT® 5720/5730 Series Options

MODEL OPTIONS

H5721



Task Chair

Pneumatic, Swivel, Tilt, Tilt Tension, Tilt Lock

H5723



Task Chair

Pneumatic, Swivel, Synchro-tilt, Tilt Tension, Tilt Lock

H5725



Task Stool

Pneumatic, Swivel, Adjustable Footring

H5731



Task Chair (Mesh Back)

Pneumatic, Swivel, Tilt, Tilt Tension, Tilt Lock

H5733



Task Chair (Mesh Back)

Pneumatic, Swivel, Synchro-tilt, Tilt Tension, Tilt Lock

H5735



Task Stool (Mesh Back)

Pneumatic, Swivel, Adjustable Footring

CASTERS



CODE	DESCRIPTION	PRICE
H	Hard Caster	+\$0



S	Soft Caster	+\$30
----------	-------------	--------------

FRAME

CODE	DESCRIPTION	PRICE
T	Black	+\$0

5720/5730 Series Fabric Options

HON BRANDED FABRICS

GRADE 1

Attire
 Centurion
 Compass
 Contourett Polyurethane
 Dapper
 Hamilton
 Inertia
 Optic

GRADE 2

Appoint Seating
 Clyde
 Dotty
 Rush
 Seed
 Spin Seating
 Whisper Vinyl

GRADE 3

In Season
 Purl
 Silvertex™ Vinyl

For a complete list of fabrics, including partnership fabrics, go to hon.com/fabricsandfinishes.

Reference Fabric Color Combinations on pages 18-22 for color codes and legend on page 19 for lead times. For additional HON to Supply COM fabric grade pricing, go to honready.hon.com and click on the HON to Supply COM link.

 For Fire Code model, availability and ordering method, refer to pages 26-29. Available on select models, contact HON Customer Support for availability.

VOLT® 5720 Series

GSA SIN 33721 EXCEPT AS NOTED



Icon Legend on page 15

H5721



TASK CHAIR

Pneumatic
Swivel
Tilt
Tilt Tension
Tilt Lock

Functions: **A, E, F, K, L**
(Function Key on pages 16-17)

DIMENSIONS

Depth:	25 ³ / ₄	Seat to Floor Height:	17 ¹ / ₄ -22 ¹ / ₄
Width:	25 ³ / ₄	Usable Seat Depth:	18 ³ / ₄
Height:	40	Ship Weight:	36
Seat Depth:	18 ³ / ₄	Cube:	5.1
Seat Width:	18 ¹ / ₂	Weight Rating:	275 lbs.
Back Width:	17 ¹ / ₄		
Back Height:	18 ³ / ₄		

FABRIC PRICE CODES

1	\$384	8	\$522
2	\$408	9	\$540
3	\$432	10	\$558
4	\$450	11	\$576
5	\$468	12	\$594
6	\$486	L	—
7	\$504		

H5723



TASK CHAIR

Pneumatic
Swivel
Synchro-tilt
Tilt Tension
Tilt Lock

Functions: **A, E, J, K, L**
(Function Key on pages 16-17)

DIMENSIONS

Depth:	25 ³ / ₄	Seat to Floor Height:	17 ¹ / ₄ -22 ¹ / ₄
Width:	25 ³ / ₄	Usable Seat Depth:	18 ³ / ₄
Height:	40	Ship Weight:	38
Seat Depth:	18 ³ / ₄	Cube:	5.1
Seat Width:	18 ¹ / ₂	Weight Rating:	275 lbs.
Back Width:	17 ¹ / ₄		
Back Height:	18 ³ / ₄		

FABRIC PRICE CODES

1	\$429	8	\$567
2	\$453	9	\$585
3	\$477	10	\$603
4	\$495	11	\$621
5	\$513	12	\$639
6	\$531	L	—
7	\$549		

H5725

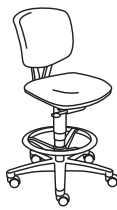

TASK STOOL

Pneumatic
Swivel
Adjustable Footring

Functions: **A, E**
(Function Key on pages 16-17)

DIMENSIONS

Depth:	29 ¹ / ₂	Seat to Floor Height:	22 ⁷ / ₈ -32 ³ / ₈
Width:	27	Usable Seat Depth:	18 ³ / ₄
Height:	49 ⁷ / ₈	Ship Weight:	39
Seat Depth:	20	Cube:	6.0
Seat Width:	19	Weight Rating:	275 lbs.
Back Width:	17 ¹ / ₄		
Back Height:	18 ³ / ₄		

FABRIC PRICE CODES

1	\$559	8	\$697
2	\$583	9	\$715
3	\$607	10	\$733
4	\$625	11	\$751
5	\$643	12	\$769
6	\$661	L	—
7	\$679		

H5795

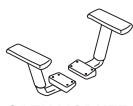

OPEN MARKET

HEIGHT-ADJUSTABLE ARMS

Non-upholstered

Functions: **Q**
(Function Key on pages 16-17)

DIMENSIONS

Adjustable Arms Width:	17 ³ / ₈
Height from Seat:	7 ⁷ / ₈ -10 ⁵ / ₈
Ship Weight:	5
Cube:	0.6

LIST PRICE

\$91

HSCASTER

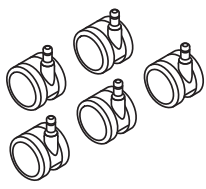

OPEN MARKET

SET OF 5 SOFT CASTERS

DIMENSIONS

Size:	60mm
Ship Weight:	2
Cube:	0.1

LIST PRICE

\$50

Available in Black finish only, no specification needed.

HON Recommendation: H5723.H.CU__T with H5795 Arm Pack - List Price \$520

HOW TO SPECIFY

Select Model Number H 5 7 2 3 .	Select Caster H Hard Caster S Soft Caster (+ \$30)	Select Fabric See page 291 CU 1 0 .	Select Frame T Black
---	---	--	--------------------------------



Icon Legend on page 15

VOLT® 5730 Series

H5731



TASK CHAIR

Mesh Back
Pneumatic
Swivel
Tilt
Tilt Tension
Tilt Lock
Functions: **A, E, F, K, L**
(Function Key on pages 16-17)

DIMENSIONS

Depth: 25³/₄ Seat to Floor Height: 18³/₄-22³/₈
Width: 26 Usable Seat Depth: 18
Height: 38³/₄ Ship Weight: 29 **Ⓢ**
Seat Depth: 18³/₄ Cube: 5.1
Seat Width: 19¹/₄ COM: 1.5
Back Width: 18 Weight Rating: **275 lbs.**
Back Height: 18³/₄

FABRIC PRICE CODES

1	\$500	8	\$569
2	\$512	9	\$578
3	\$524	10	\$587
4	\$533	11	\$596
5	\$542	12	\$605
6	\$551	L	—
7	\$560		

H5733



TASK CHAIR

Mesh Back
Pneumatic
Swivel
Synchro-tilt
Tilt Tension
Tilt Lock
Functions: **A, E, J, K, L**
(Function Key on pages 16-17)

DIMENSIONS

Depth: 25³/₄ Seat to Floor Height: 17³/₈-21¹/₈
Width: 26 Usable Seat Depth: 17⁷/₈
Height: 38¹/₂ Ship Weight: 32 **Ⓢ**
Seat Depth: 18³/₄ Cube: 5.1
Seat Width: 19¹/₄ COM: 1.5
Back Width: 18 Weight Rating: **275 lbs.**
Back Height: 18³/₄

FABRIC PRICE CODES

1	\$546	8	\$615
2	\$558	9	\$624
3	\$570	10	\$633
4	\$579	11	\$642
5	\$588	12	\$651
6	\$597	L	—
7	\$606		

H5735



TASK STOOL

Mesh Back
Pneumatic
Swivel
Adjustable Footring
Functions: **A, E**
(Function Key on pages 16-17)

DIMENSIONS

Depth: 28 Seat to Floor Height: 22⁷/₈-32³/₈
Width: 26 Usable Seat Depth: 18
Height: 49⁷/₈ Ship Weight: 36 **Ⓢ**
Seat Depth: 20 Cube: 6.0
Seat Width: 19 COM: 1.5
Back Width: 18 Weight Rating: **275 lbs.**
Back Height: 18¹/₂

FABRIC PRICE CODES

1	\$680	8	\$749
2	\$692	9	\$758
3	\$704	10	\$767
4	\$713	11	\$776
5	\$722	12	\$785
6	\$731	L	—
7	\$740		

H5795

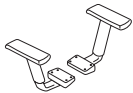

HEIGHT-ADJUSTABLE ARMS

Non-upholstered
Functions: **Q**
(Function Key on pages 16-17)

DIMENSIONS

Adjustable Arms Width: 17³/₈
Height from Seat: 7³/₈-10³/₈
Ship Weight: 5 **Ⓢ**
Cube: 0.6

LIST PRICE

\$91

HSCASTER

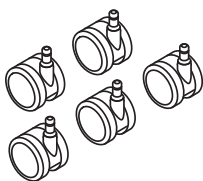

SET OF 5 SOFT CASTERS

DIMENSIONS

Size: 60mm
Ship Weight: 2 **Ⓢ**
Cube: 0.1

LIST PRICE

\$50

! Available in Black finish only, no specification needed.

HON Recommendation: H5733.H.CU__T with H5795 Arm Pack - List Price \$637

HOW TO SPECIFY

Select Model Number H 5 7 3 3 -	Select Caster H Hard Caster S Soft Caster (+ \$30) H -	Select Fabric See page 291 CU10 -	Select Frame T Black T
---	--	--	---

WAVE™ Mesh Chairs

GSA SIN AS NOTED



Icon Legend on page 15

HVL701



SIN 33721

HIGH-BACK

Pneumatic
Swivel
Knee Tilt
Tilt Tension
Infinite Tilt Lock
Adjustable Lumbar
Height-adjustable Arms

Functions: **A, E, H, K, L, Q, W**
(Function Key on pages 16-17)

DIMENSIONS

Depth:	28	Arm Width:	19½
Width:	27½	Seat to Floor Height:	18½-21¼
Height:	44⅝	Usable Seat Depth:	19¼
Seat Depth:	20¾	Ship Weight:	53 Ⓢ
Seat Width:	22	Cube:	5.8
Back Width:	23	Weight Rating:	250 lbs.
Back Height:	23¾		

PRICE CODE

Leather **\$656**

NOTES: Comfortable and breathable mesh back. Sturdy textured black frame. HVL701 has a Black leather upholstered seat with side mesh panels. Adjustable lumbar support. **HON 5-Year Limited Warranty.**

HON Recommendation: HVL701.SB11 - List Price \$656

HVL702



OPEN MARKET

HIGH-BACK

Pneumatic
Swivel
Synchro-tilt
Tilt Tension
Tilt Lock
Height-adjustable Arms

Functions: **A, E, J, K, L, Q**
(Function Key on pages 16-17)

DIMENSIONS

Depth:	26½	Arm Width:	19½
Width:	26½	Seat to Floor Height:	18½-23½
Height:	40½	Usable Seat Depth:	19¾
Seat Depth:	19¾	Ship Weight:	40 Ⓢ
Seat Width:	21	Cube:	5.0
Back Width:	19½	Weight Rating:	250 lbs.
Back Height:	24		

PRICE CODE

Sandwich Mesh **\$532**

NOTES: Black Sandwich Mesh seat and mesh back. **HON 5-Year Limited Warranty.**

HON Recommendation: HVL702.MM10 - List Price \$532

HVL705



OPEN MARKET

EXECUTIVE BIG AND TALL

Pneumatic
Knee Tilt
Tilt Tension
Tilt Lock
Height and Width Adjustable Arms
Integrated Lumbar Support

Functions: **A, E, H, K, L, S**
(Function Key on pages 16-17)

DIMENSIONS

Depth:	25⅝	Back Height:	28
Width:	30¼	Seat to Floor Height:	19¼-22¼
Height:	42⅝	Usable Seat Depth:	18¾
Seat Depth:	18¾	Ship Weight:	59 Ⓢ
Seat Width:	21⅝	Cube:	6.1
Back Width:	22¾	Weight Rating:	450 lbs.

PRICE CODE

Mesh **\$784**

NOTES: Large scale model HVL705 will support up to 450 lbs with normal use. Available in Black Mesh fabric VM10. **HON 5-Year Limited Warranty.**

HON Recommendation: HVL705.VM10 - List Price \$784

HVL712



SIN 33721

MID-BACK

Pneumatic
Swivel
Synchro-tilt
Tilt Tension
Tilt Lock
Height-adjustable Arms

Functions: **A, E, J, K, L, Q**
(Function Key on pages 16-17)

DIMENSIONS

Depth:	28½	Arm Width:	18⅝
Width:	29½	Seat to Floor Height:	18-22¼
Height:	41¾	Usable Seat Depth:	18
Seat Depth:	18½	Ship Weight:	39 Ⓢ
Seat Width:	19¾	Cube:	5.4
Back Width:	20½	Weight Rating:	250 lbs.
Back Height:	20¾		

PRICE CODE

Sandwich Mesh **\$449**

NOTES: Black Sandwich Mesh seat and mesh back. **HON 5-Year Limited Warranty.**

HON Recommendation: HVL712.MM10 - List Price \$449

HOW TO SPECIFY

Select Model Number	Select Fabric
SB11 Black SofThread™ Leather <i>Specify for model HVL701 only</i>	
MM10 Black Sandwich Mesh Fabric <i>Specify for models HVL702 and HVL712 only</i>	
VM10 Black Mesh Fabric <i>Specify for model HVL705 only</i>	

HVL701	SB11
--------	------



EXECUTIVE CHAIRS

HVL105



HIGH-BACK

Pneumatic
Swivel
Tilt
Tilt Tension
Tilt Lock
Fixed Padded Arms

Functions: **A, E, F, K, L**
(Function Key on pages 16-17)

DIMENSIONS

Depth:	27½	Arm Width:	19
Width:	25	Seat to Floor Height:	17½-20¼
Height:	45¾	Usable Seat Depth:	20¼
Seat Depth:	20¼	Ship Weight:	46.0 Ⓢ
Seat Width:	19½	Cube:	6.6
Back Width:	20½	Weight Rating:	250 lbs.
Back Height:	28¾		

PRICE CODE

Leather **\$505**

NOTES: Black SofThread™ Leather. Polished base. Fixed, padded arms. **HON 5-Year Limited Warranty.**

HON Recommendation: HVL105.SB11 - List Price \$505

HVL131



HIGH-BACK

Pneumatic
Swivel
Tilt
Tilt Tension
Tilt Lock
Fixed Padded Loop Arms

Functions: **A, E, F, K, L, T**
(Function Key on pages 16-17)

DIMENSIONS

Depth:	40	Arm Width:	20½
Width:	28½	Seat to Floor Height:	18½-22
Height:	45½	Usable Seat Depth:	18¼
Seat Depth:	18¼	Ship Weight:	42 Ⓢ
Seat Width:	20¾	Cube:	6.3
Back Width:	20¾	Weight Rating:	250 lbs.
Back Height:	26⅞		

PRICE CODE

Vinyl **\$442**

NOTES: Black vinyl with contrasting top stitch. Black frame. Padded loop arms. **HON 5-Year Limited Warranty.**

HON Recommendation: HVL131.EN11 - List Price \$442

HVL151



HIGH-BACK

Pneumatic
Swivel
Tilt
Tilt Tension
Tilt Lock
Fixed Padded Loop Arms

Functions: **A, E, F, K, L, T**
(Function Key on pages 16-17)

DIMENSIONS

Depth:	37½	Arm Width:	20½
Width:	27	Seat to Floor Height:	17¾-21½
Height:	45½	Usable Seat Depth:	18⅝
Seat Depth:	18⅝	Ship Weight:	38 Ⓢ
Seat Width:	20½	Cube:	5.1
Back Width:	20½	Weight Rating:	250 lbs.
Back Height:	27¼		

PRICE CODE

Leather **\$382**

NOTES: Black SofThread™ Leather. Black frame. Padded loop arms. **HON 5-Year Limited Warranty.**

HON Recommendation: HVL151.SB11 - List Price \$382

HOW TO SPECIFY

Select
Model Number

Select
Fabric

SB11 Black SofThread™ Leather
Specify for models HVL105 and HVL151 only

EN11 Black Vinyl
Specify for model HVL131 only

H V L 1 0 5 .

S B 1 1



EXECUTIVE CHAIRS

HVL161



HIGH-BACK

Pneumatic
Swivel
Tilt
Tilt Tension
Tilt Lock
Fixed Padded Loop Arms

Functions: **A, E, F, K, L, T**
(Function Key on pages 16-17)

DIMENSIONS

Depth:	39 $\frac{1}{4}$	Arm Width:	19
Width:	25 $\frac{5}{8}$	Seat to Floor Height:	18 $\frac{3}{8}$ -22 $\frac{1}{8}$
Height:	45	Usable Seat Depth:	18 $\frac{3}{4}$
Seat Depth:	18 $\frac{3}{4}$	Ship Weight:	35 Ⓢ
Seat Width:	19	Cube:	4.8
Back Width:	19	Weight Rating:	250 lbs.
Back Height:	26 $\frac{3}{8}$		

PRICE CODE

Leather **\$358**

NOTES: Black SofThread™ Leather. Black frame. Padded loop arms. **HON 5-Year Limited Warranty.**

HON Recommendation: HVL161.SB11 - List Price \$358

HVL171



MID-BACK

Pneumatic
Swivel
Tilt
Tilt Tension
Tilt Lock
Fixed Loop Arms

Functions: **A, E, F, K, L, T**
(Function Key on pages 16-17)

DIMENSIONS

Depth:	34 $\frac{1}{2}$	Arm Width:	19 $\frac{3}{8}$
Width:	25 $\frac{5}{8}$	Seat to Floor Height:	16 $\frac{3}{4}$ -20 $\frac{1}{2}$
Height:	38 $\frac{3}{4}$	Usable Seat Depth:	17 $\frac{3}{4}$
Seat Depth:	17 $\frac{3}{4}$	Ship Weight:	26 Ⓢ
Seat Width:	19 $\frac{3}{8}$	Cube:	3.9
Back Width:	18 $\frac{3}{4}$	Weight Rating:	250 lbs.
Back Height:	21 $\frac{1}{4}$		

PRICE CODE

Leather **\$291**

NOTES: Black SofThread™ Leather. Black frame. Loop arms. **HON 5-Year Limited Warranty.**

HON Recommendation: HVL171.SB11 - List Price \$291

HVL402



HIGH-BACK

Pneumatic
Swivel
Tilt
Tilt Tension
Tilt Lock
Fixed Padded Loop Arms

Functions: **A, E, F, K, L, T**
(Function Key on pages 16-17)

DIMENSIONS

Depth:	28	Arm Width:	19 $\frac{1}{2}$
Width:	26	Seat to Floor Height:	16 $\frac{1}{2}$ -20 $\frac{1}{2}$
Height:	45 $\frac{1}{2}$	Usable Seat Depth:	17 $\frac{1}{2}$
Seat Depth:	17 $\frac{1}{2}$	Ship Weight:	44 Ⓢ
Seat Width:	19 $\frac{1}{2}$	Cube:	6.1
Back Width:	19	Weight Rating:	250 lbs.
Back Height:	24 $\frac{1}{2}$		

PRICE CODE

Vinyl **\$425**

NOTES: Available in Black and Brown vinyl with contrasting top stitch. EN11 features silver frame. EN45 features black frame. Padded loop arms. **HON 5-Year Limited Warranty.**

HON Recommendation: HVL402.EN11 - List Price \$425

HOW TO SPECIFY

Select Model Number

Select Fabric

- SB11** Black SofThread™ Leather
Specify for models HVL161 and HVL171
- EN11** Black Vinyl
Specify for model HVL402 only
- EN45** Brown Vinyl
Specify for model HVL402 only

H V L 1 6 1 .

S B 1 1



EXECUTIVE CHAIRS

HVL601



HIGH-BACK

Pneumatic
Swivel
Tilt
Tilt Tension
Tilt Lock
Loop Arms

Functions: **A, E, F, K, L, T**
(Function Key on pages 16-17)

DIMENSIONS

Depth:	27	Arm Width:	20½
Width:	26½	Seat to Floor Height:	16¾-20½
Height:	44	Usable Seat Depth:	17
Seat Depth:	17	Ship Weight:	38 Ⓢ
Seat Width:	20½	Cube:	4.1
Back Width:	20½	Weight Rating:	250 lbs.
Back Height:	26½		

PRICE CODE

Fabric	\$281
Leather	\$311

NOTES: Tailored stitching detail in Black SofThread™ Leather or Black or Navy fabric. Fixed loop arms. Black frame. **HON 5-Year Limited Warranty.**

HON Recommendation: HVL601.SB11 - List Price \$311

HOW TO SPECIFY

Select Model Number

Select Fabric

SB11 Black SofThread™ Leather
VA10 Black Fabric
VA90 Navy Fabric

H V L 6 0 1 .

S B 1 1



Icon Legend on page 15

GUEST CHAIRS

HVL653



GUEST CHAIR

Sled Base
Padded Arms

DIMENSIONS

Depth:	23	Arm Width:	17 ³ / ₄
Width:	22 ¹ / ₄	Seat to Floor Height:	17 ⁵ / ₈
Height:	32	Usable Seat Depth:	16 ³ / ₄
Seat Depth:	17	Ship Weight:	28 Ⓢ
Seat Width:	20 ¹ / ₄	Cube:	3.1
Back Width:	18 ¹ / ₂	Weight Rating:	250 lbs.
Back Height:	12		

PRICE CODE

Leather **\$246**

NOTES: Black SofThread™ Leather with tailored stitching detail. Frame features steel tubular construction. Black frame.

HON Recommendation: HVL653.SB11 - List Price \$246

HOW TO SPECIFY

Select Model Number	Select Fabric SB11 Black SofThread™ Leather
H V L 6 5 3 .	S B 1 1



MESH CHAIRS

HVL521



MID-BACK

Pneumatic
Swivel
Tilt
Tilt Tension
Tilt Lock
Arms

Functions: **A, E, F, K, L**
(Function Key on pages 16-17)

DIMENSIONS

Depth:	35¼	Arm Width:	18½
Width:	26¼	Seat to Floor Height:	17½-22
Height:	41	Usable Seat Depth:	17¾
Seat Depth:	17¾	Ship Weight:	30 Ⓢ
Seat Width:	19½	Cube:	4.1
Back Width:	18¾	Weight Rating:	250 lbs.
Back Height:	21½		

PRICE CODE

Fabric **\$331**

NOTES: Comfortable and breathable mesh back. Black fabric seat. Sturdy textured black frame. Fixed-height arms. **HON 5-Year Limited Warranty.**

HON Recommendation: HVL521.VA10 - List Price \$331

HVL525



HIGH-BACK

Pneumatic
Swivel
Tilt
Tilt Tension
Tilt Lock
Fixed Loop Arms

Functions: **A, E, F, K, L, T**
(Function Key on pages 16-17)

DIMENSIONS

Depth:	26	Arm Width:	20⅞
Width:	26	Seat to Floor Height:	16¾-21¼
Height:	42¾	Usable Seat Depth:	19
Seat Depth:	19	Ship Weight:	33 Ⓢ
Seat Width:	19¾	Cube:	3.8
Back Width:	19¾	Weight Rating:	250 lbs.
Back Height:	23		

PRICE CODE

Fabric **\$338**

NOTES: Comfortable and breathable mesh back. Black upholstered seat. Fixed, loop arms. **HON 5-Year Limited Warranty.**

HON Recommendation: HVL525.ES10 - List Price \$338

HOW TO SPECIFY

Select
Model Number

Select
Fabric

VA10 Black Fabric
Specify for model HVL521 only

ES10 Black Fabric
Specify for model HVL525 only

H V L 5 2 1 .

V A 1 0



NESTING CHAIRS

HVL303



SANDWICH MESH BACK AND SEAT

Upholstered Seat and Back
Casters
Arms

DIMENSIONS

Depth:	23¾	Back Height:	16
Width:	23¾	Seat to Floor Height:	19¼
Height:	33½	Usable Seat Depth:	18½
Seat Depth:	18½	Ship Weight:	27
Seat Width:	19½	Cube:	2.1
Back Width:	19½	Weight Rating:	250 lbs.

LIST PRICE

\$299

NOTES: Seat and back upholstered in comfortable and breathable Black Sandwich Mesh. Specify Black (T) or Silver (X) frame. Ships one per carton. **HON 5-Year Limited Warranty.**

HON Recommendation: HVL303.MM10.T - List Price \$299

HOW TO SPECIFY

<p>Select Model Number</p> <div style="border: 1px solid #ccc; padding: 5px; display: flex; justify-content: space-between; margin-top: 10px;"> HVL303 </div>	<p>Select Fabric</p> <p>MM10 Black Sandwich Mesh Fabric (only)</p> <div style="border: 1px solid #ccc; padding: 5px; display: flex; justify-content: space-between; margin-top: 10px;"> MM10 </div>	<p>Select Frame</p> <p>T Black X Silver</p> <div style="border: 1px solid #ccc; padding: 5px; display: flex; justify-content: space-between; margin-top: 10px;"> T </div>
--	---	---



TASK CHAIRS

HVL220

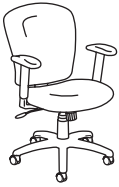

TASK MID-BACK

- Pneumatic
- Swivel
- Tilt
- Tilt Tension
- Tilt Lock
- Height-adjustable Arms

Functions: **A, E, F, K, L, Q**
(Function Key on pages 16-17)

DIMENSIONS

Depth:	34½	Arm Width:	17¾
Width:	26¾	Seat to Floor Height:	17½-21¼
Height:	41	Usable Seat Depth:	16¾
Seat Depth:	16¾	Ship Weight:	35 Ⓢ
Seat Width:	20	Cube:	3.7
Back Width:	20¼	Weight Rating:	250 lbs.
Back Height:	22½		

PRICE CODE

Fabric **\$358**

NOTES: Black fabric. Sturdy textured black frame. Height-adjustable arms. **HON 5-Year Limited Warranty.**

HON Recommendation: HVL220.VA10 - List Price \$358

HOW TO SPECIFY

<p>Select Model Number</p>	<p>Select Fabric</p> <p>VA10 Black Fabric</p>
<p>H V L 2 2 0 .</p>	<p>V A 1 0</p>

COLLABORATIVE CHAIRS

Modular Lounge

OPEN MARKET



Icon Legend on page 15

HVL864

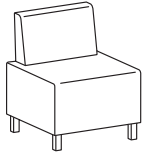

MODULAR CHAIR

DIMENSIONS

Depth:	25	Arm Width:	25
Width:	25	Seat to Floor Height:	17¼
Height:	30⅞	Usable Seat Depth:	18½
Seat Depth:	18½	Ship Weight:	33 Ⓢ
Seat Width:	25	Cube:	5.5
Back Width:	21½	Weight Rating:	250 lbs.
Back Height:	15⅜		

PRICE CODE

Leather **\$668**

NOTES: Thick cushioning and individually pocketed coil springs provide long-lasting comfort. Lightweight frame. Easier assembly – no tools required. SofThread™ leather.

HON Recommendation: HVL864.SB11 - List Price \$668

HVL862

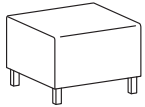

OTTOMAN

DIMENSIONS

Depth:	25	Seat to Floor Height:	17¼
Width:	25	Usable Seat Depth:	25
Height:	18¼	Ship Weight:	31 Ⓢ
Seat Depth:	25	Cube:	5.5
Seat Width:	25	Weight Rating:	250 lbs.

PRICE CODE

Leather **\$485**

NOTES: Thick cushioning and individually pocketed coil springs provide long-lasting comfort. Functions as footrest, seat or side table. SofThread™ leather. Easier assembly – no tools required.

HON Recommendation: HVL862.SB11 - List Price \$485

HOW TO SPECIFY

<p>Select Model Number</p>	<p>Select Fabric</p> <p>SB11 Black SofThread™ Leather (only)</p>
H V L 8 6 4 .	S B 1 1



HVL981



RECTANGLE WOBBLE BOARD

Anti-Fatigue Mat

DIMENSIONS

Depth: 18
Width: 22¼
Height: 3

Ship Weight: 10.0 Ⓢ
Cube: 0.9
Weight Rating: 250 lbs.

LIST PRICE

\$120

NOTES: HON 5-Year Limited Warranty.

ⓘ Available in Black (T) finish ONLY.

SPECIFYING EXAMPLE: HVL981.T

HVL982

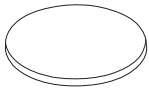

ROUND WOBBLE BOARD

Anti-Fatigue Mat

DIMENSIONS

Depth: 18½
Width: 18½
Height: 2½

Ship Weight: 5.8 Ⓢ
Cube: 0.6
Weight Rating: 250 lbs.

LIST PRICE

\$102

NOTES: HON 5-Year Limited Warranty.

ⓘ Available in Black (T) finish ONLY.

SPECIFYING EXAMPLE: HVL982.T

HBEAFM1

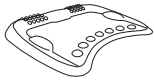

ANTI-FATIGUE MAT

Ergonomic

DIMENSIONS

Depth: 25
Width: 29⅞
Height: 2¾

Ship Weight: 7.0
Cube: 1.4

LIST PRICE

\$219

NOTES: HON 5-Year Limited Warranty.

ⓘ Available in Black ONLY. No specification needed.

SPECIFYING EXAMPLE: HBEAFM1

HBAFM2036

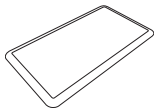

ANTI-FATIGUE MAT

Rectangle

DIMENSIONS

Depth: 20
Width: 36
Height: ¾

Ship Weight: 5.4
Cube: 0.4

LIST PRICE

\$100

NOTES: HON 5-Year Limited Warranty.

ⓘ Available in Black ONLY. No specification needed.

SPECIFYING EXAMPLE: HBAFM2036

HVL991

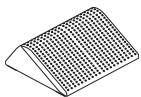

FOOTREST

Anti-Slip Cover

DIMENSIONS

Depth: 13¾
Width: 16
Height: 5½

Ship Weight: 7.0 Ⓢ
Cube: 0.9
Weight Rating: 250 lbs.

LIST PRICE

\$82

NOTES: HON 5-Year Limited Warranty.

ⓘ Available in Black (T) finish ONLY.

SPECIFYING EXAMPLE: HVL991.T

HSCASTER

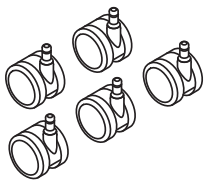

SET OF 5 SOFT CASTERS

DIMENSIONS

Size: 60mm
Ship Weight: 2 Ⓢ
Cube: 0.1

LIST PRICE

\$50

ⓘ Available in Black finish only, no specification needed.

HOW TO SPECIFY

Select Model Number

H V L 9 8 1 .

Select Finish

T Black

T

WORKPLACE TOOLS

Chair Mats

OPEN MARKET

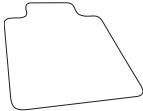
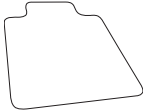
	DESCRIPTION	MODEL	SHIP WEIGHT	CUBE	LIST PRICE
	Lipped Chair Mat with Studs 60"W x 46"D 48"W x 36"D NOTES: Clear finish only. Available in 60"W x 46"D and 48"W x 36"D sizes. Features rectangle and lipped shapes. Available with studs for carpet and without studs for hard-surface floors. Ships rolled. HON 5-Year Limited Warranty. ⓘ Clear finish only. No specification needed.	HCM4660LS	13.9	1.0	\$146
		HCM3648LS	8.8	0.6	\$88
	Lipped Chair Mat without Studs 60"W x 46"D 48"W x 36"D NOTES: Clear finish only. Available in 60"W x 46"D and 48"W x 36"D sizes. Features rectangle and lipped shapes. Available with studs for carpet and without studs for hard-surface floors. Ships rolled. HON 5-Year Limited Warranty. ⓘ Clear finish only. No specification needed.	HCM4660LN	13.2	0.5	\$146
		HCM3648LN	8.3	0.3	\$88

HOW TO SPECIFY

Select Model Number

H C M 4 6 6 0 L S

CROSS REFERENCE INDEX

MODEL	PAGE	MODEL	PAGE	MODEL	PAGE	MODEL	PAGE
H2091	226	H5991	57	HFLYO1DF	103	HICS7	154
H2092	226	H5995	57	HFSS7	96	HICS7DF	156
H2093	226	HBAFM2036	303	HFSS74L	96	HIEH1	140
H2095	226	HBEAFM1	220, 303	HFSS74LDF	98	HIEH2	140
H2111	160	HCAT1MM	62	HFTB17N	108	HIEH3	140
H2112	160	HCG6	49	HFTLA2460	107	HIGB1	151, 156
H2141	161	HCG6DF	49	HFTLA3372	107	HIGCL	153
H2142	161	HCM3648LN	304	HFTLA3384	107	HIGS6	154
H2143	161	HCM3648LS	304	HFTLA3396	107	HIGS6DF	155
H2144	161	HCM4660LN	304	HFTLC2460	107	HILMBR	151
H2145	161	HCM4660LS	304	HFTLC3372	107	HIPAA	76, 142, 151
H2146	161	HCT1MM	61	HFTLC3384	107	HISB6	154
H2164	43	HCW1	48	HFTLC3396	107	HISB6DF	155
H2165	43	HFAA01	164	HFTLD26	111	HITL1	138
H2191	229	HFAL02	164	HFTLD30	107	HITL2	138
H2192	229	HFAS03	164	HFTLD36	107	HITL3	138
H2194	229	HFCG6	96	HFTLR12	111	HITLM	145
H2281	168	HFCG6DF	98	HFTLS24	111	HITLMKD	146
H2282	169	HFCL2	97	HFTLS30	107	HITLRA	147
H2283	168	HFCL2DF	99	HFTLS36	107	HITLRAKD	148
H2284	169	HFDB17B	108	HFTLW45	111	HITS5	141
H2285	170	HFDB17N	108	HFTPTL18	110	HITSM	145
H4001	250	HFDB29A	108	HFTTAL14	112, 125, 130	HITSRA	147
H4002	250	HFDB29AN	108	HFXB17B	108	HIWM1	139
H4003	250	HFDB29B	108	HFXB29A	108	HIWM2	139
H4008	250	HFDB42A	109	HFXB29AN	108	HIWM3	139
H4031	132	HFDB42AF	109	HFXB29B	108	HIWM8	141
H4033	132	HFDB42AF72	109	HFXB42A	109	HIWMM	145
H4039	132	HFDB42AF84	109	HFXB42AN	109	HIWMMKD	146
H4041	205	HFDB42AF96	109	HFXB42B	109	HIWMRA	147
H4043	205	HFDB42AFN	109	HGDK3-F	245	HIWMRAKD	148
H4048	205	HFDB42AN	109	HGRMTAC	113, 125, 130	HIWMU	149
H4049	205	HFDB42B	109	HGRMTAC2	113, 125, 130	HIWMUKD	150
H4069	213	HFDB42BF	109	HGRMTDATA	113	HIWMUL	149
H4071	209	HFL450	86	HGRMTUSB2	113, 125, 130	HIWMULKD	150
H4073	209	HFLB2	93	HGTMM	116	HL2DARM	76
H4075	210	HFLB3	93	HGV1MM	117	HL4DARM	76
H4077	210	HFLCC1	85	HHB02	283	HLEU	71
H4079	213	HFLCC1DF	91	HHB03	283	HLEUBT	74
H4091	211	HFLCO1	102	HHCB50	285	HLMSSHRR	76
H4093	211	HFLCO1DF	103	HHCG11	267	HITM	73
H4095	212	HFLGANG	86	HHCG11DF	268	HITP	73
H4097	212	HFLMC1	84	HHCG21	267	HITSM	75
H4099	213	HFLMC1DF	89	HHCG21DF	268	HITSP	75
H5001	216	HFLMC1S	87	HHCG50	267	HITSU	75
H5002	216	HFLMC1SDF	92	HHCG50DF	269	HLTU	73
H5021	219	HFLML1	84	HHCGB21	270	HLWM	72
H5022	219	HFLML1DF	89	HHCGB31	270	HLWMBT	74
H5023	219	HFLMR1	84	HHCGBR	272	HLWU	72
H5701	288	HFLMR1DF	90	HHCGBRCH	272	HLWUBT	74
H5703	288	HFLRC1	83	HHCP1	267	HME3	174
H5705	288	HFLRC1DF	88	HHCP1DF	269	HMG1	184
H5711	289	HFLRC1S	87	HHCT01	285	HMG2	184
H5713	289	HFLRC1SDF	92	HHCT02	285	HMG3	185
H5715	289	HFLSC1	83	HHCT020	284	HMG4	185
H5721	292	HFLSC1DF	88	HHCT024	284	HMG5	185
H5723	292	HFLSC1S	87	HHCT048	284	HMG7	185
H5725	292	HFLSC1SDF	92	HHCT12	285	HMG11	191
H5731	293	HFLSC2	97	HHCTC	271	HMG12	191
H5733	293	HFLSC2DF	99	HHCTL4	271	HMH01	40
H5735	293	HFLSO1	86	HHCTRT	271	HMH02	40
H5795	288, 289, 292, 293	HFLWI45	85	HHCTS	271	HML1S	122
H5901	56	HFLWI45DF	91	HI2AAA	142, 151	HML1SDF	126
H5902	56	HFLWO45	85	HI2ATA	142, 151	HML2S	122
H5903	56	HFLWO45DF	91	HI2FHA	76, 142, 151	HML2SDF	127
H5905	57	HFLYO1	102	HIB50	153	HML2ST	124

CROSS REFERENCE INDEX

MODEL	PAGE	MODEL	PAGE	MODEL	PAGE	MODEL	PAGE
HML2STDF	129	HSCS1	33	HTSSRD	93	HVL539	231
HML3S	123	HSCS1DF	35	HVL102	276	HVL541	77
HML3SDF	128	HSCS2	34	HVL103	276	HVL581	65
HML8851	64	HSCS2DF	36	HVL105	295	HVL582	65
HML8852	64	HSGANG	33, 36	HVL108	66	HVL585	65
HMN1	188	HSGS6	33	HVL131	295	HVL601	297
HMN2	188	HSGS6DF	35	HVL149	237	HVL604	277
HMNT1	194	HSLV2DAP	262	HVL151	295	HVL605	277
HMNT2	194	HSLV4DAP	262	HVL161	296	HVL606	238
HMS1	180	HSLVFAP	262	HVL171	296	HVL616	238
HMS2	180	HSLVLMBR	262	HVL205	278	HVL643	50
HMSCART	180	HSLVSMM	256	HVL210	278	HVL653	298
HMSFLTGLD	181	HSLVSMMS	256	HVL215	278	HVL685	277
HMSGANG	181	HSLVSMR	258	HVL220	301	HVL691	52
HMSGLD	181	HSLVSMRS	258	HVL232	172	HVL693	52
HMSSTLGLD	181	HSLVSMU	260	HVL238	172	HVL701	294
HMT1	178	HSLVSMUS	260	HVL281	195	HVL702	294
HMT5	178	HSLVTMM	255	HVL282	195	HVL705	294
HMTS01	37	HSLVTMMKD	261	HVL283	195	HVL712	294
HMTS11	37	HSLVTMMS	255	HVL289	195	HVL721	78
HN1	202	HSLVTMR	257	HVL303	300	HVL791	197
HN1U	202	HSLVTMRKD	261	HVL304	38	HVL844	274
HN6	203	HSLVTMRS	257	HVL314	38	HVL852	274
HN7	203	HSLVTMU	259	HVL402	296	HVL853	274
HNATA	203	HSLVTMUKD	261	HVL508	157	HVL862	302
HNFPA	203	HSLVTMUS	259	HVL511	275	HVL864	302
HPN1	223	HSS4L-06A	244	HVL515	275	HVL871	51
HPN2	223	HSS4L-12A	244	HVL518	157	HVL872	51
HPWRMOD2UWM	113	HSS4L-14A	244	HVL521	299	HVL873	51
HPWRMOD3UWM	113	HSS4L-16B	245	HVL525	299	HVL887	63
HQQ1	240	HSS4L-18B	245	HVL528	157	HVL888	63
HQQ1CUSH	240	HSSA-WB1618	245	HVL530	230	HVL951	273
HQTMM	235	HSSCL-14A	246	HVL531	230	HVL981	303
HQTSM	235	HSSCL-16B	246	HVL532	230	HVL982	303
HSB50	34	HSSCL-18B	246	HVL534	231	HVL991	220, 303
HSB50DF	36	HSSST-18B	247	HVL536	231	HVL995	278
HSCASTER	61, 62, 76, 142, 151, 262, 292, 293, 303	HSSTK-18B	247	HVL537	231	HVLPERCH	220
		HTPWRGROM1	125, 130	HVL538	157		

NOTES

NOTES

NOTES

NOTES

NOTES

NOTES

INFORMATION ON ORDERING PARTS

When parts are needed to repair HON products, the following guidelines should be followed to expedite the process.

1. Warranty orders are submitted on HON Ready via the Quick Claim tool. To purchase repair parts, please visit HONAccessories.com which can be found on HON.com.
2. There are no discounts applied to parts. Pricing quoted is the net value. Parts pricing is subject to change without notice.
3. For a part not covered by warranty applicable shipping charges will apply.
4. Parts may be paid for with an approved credit card. Approved Cards: MasterCard, VISA and American Express.
5. Payment terms for invoiced parts are Net 30 days.
6. Due to short lead times on parts, no changes will be accepted after the order has been placed.
7. When placing a **warranty** parts order:

If the product is under warranty, the product serial number must be provided. Most finished goods products have a serial number placed on them at the factory. The label containing the serial number is located:

Tables and Stands — underside of the top

Table Trucks — underside of side rail

Seating — underside of the seat

NOTE: Removal of the serial number tag from the product voids the warranty.

An important note regarding Product Serial Numbers:

HON tables and chairs are tagged with a serial number. This number helps us identify *when and where your product was made*, and to identify and correct the root causes for the problem. NEITHER THE DEALER NOR THE CONSUMER SHOULD REMOVE THIS TAG UNDER ANY CIRCUMSTANCES. To do so immediately voids your Warranty coverage for that particular item *and prevents us from further identifying it*. Instead, please transcribe the number and call your Dealer.

ABOUT® ORDERING INFORMATION

GALLERY PANELS, WORKSURFACES, COUNTERTOPS, CORNER SHELVES W/EDGE BAND, HARD-SURFACE TILE OVERHEAD STORAGE DOORS*

L1 LAMINATES CODES

Woodgrain

- ◆ Bourbon Cherry H
- ◆ Cognac COGN
- ◆ Florence Walnut LFW1
- ◆ Harvest C
- ◆ Kingswood Walnut LK11
- ◆ Mahogany N
- ◆ Mocha MOCH
- ◆ Natural Maple D
- ◆ Pinnacle PINC
- ◆ Shaker Cherry F
- ◆ Sterling Ash LSA1

Solid

- ◆ Black P
- ◆ Charcoal S
- ◆ Designer White LDW1
- ◆ Loft LOFT

Patterned

- ◆ Sheer Mesh A5
- ◆ Silver Mesh B9
- ◆ Steel Mesh A9
- ◇ Canyon Zephyr K9
- ◇ Desert Zephyr K8
- ◇ Shadow Zephyr K1
- ◆ Gray G2
- ◆ Grey Tigris L6
- ◇ White G1
- ◆ Whitestone K4

L2 LAMINATES CODES

Woodgrain

- ◆ Lowell Ash LLA1
- ◆ Natural Recon LNRI
- ◆ Phantom Ecru LPE1
- ◆ Portico Teak LPT1
- ◆ Skyline Walnut LSW1

(Door panels not available in L2)

► LAMINATE TOPS

SPECIFY: Model Number.
Laminate
Edge Color
Grommet Color

EXAMPLE: HWR2424P.K8.R.T5

► PAINTED PRODUCTS

SPECIFY: Model Number.
Paint Color

EXAMPLE: HRVSHV24.T1

► PANEL FRAMES

SPECIFY: Model Number.
Paint

EXAMPLE: HRVF3524P.T3

Suffix "A"



Satin Chrome
Arch Pull

* Laminate Front Overheads only available in L1 Woodgrain Laminates.

◆◆◆ For lead time information see page 19.

* De-emphasized

WORKSURFACE EDGE BAND

- ◆ Black P
- ◆ Bourbon Cherry H
- ◆ Charcoal S
- ◆ Cognac COGN
- ◆ Designer White LDW1
- ◆ Florence Walnut LFW1
- ◆ Greige T5
- ◆ Harvest C
- ◆ Kingswood Walnut LK11
- ◆ Light Gray Q
- ◆ Loft LOFT
- ◆ Lowell Ash LLA1
- ◆ Mahogany N
- ◆ Mocha MOCH
- ◆ Muslin T3
- ◆ Natural Maple D
- ◆ Natural Recon LNRI
- ◆ Phantom Ecru LPE1
- ◆ Pinnacle PINC
- ◆ Platinum PLAT
- ◆ Portico Teak LPT1
- ◇ Shadow * SHDW
- ◆ Shaker Cherry F
- ◆ Skyline Walnut LSW1
- ◆ Sterling Ash SA

WORKSURFACE GROMMET

- ◆ Black P
- ◆ Brownstone EY
- ◆ Charcoal S
- ◆ Fossil EH
- ◆ Greige T5
- ◆ Light Gray Q
- ◆ Loft LOFT
- ◆ Muslin T3
- ◆ Shadow * SHDW
- ◆ Titanium TI
- ◆ Designer White DW
- ◆ Champagne Metallic T4
- ◆ Platinum Metallic T1

Edge Treatments



"P" Edgeband

(Color must be selected.)

► HOW TO ORDER

- 1) Select desired model numbers.
- 2) Order worksurfaces to correspond to width of panel behind them.
- 3) Add appropriate prefix and suffix if Tee-Span worksurfaces are needed.

FRAMES, TRIM, METAL TILES, CUSTOM BRACKET KIT, WORKSURFACE SUPPORTS, STEEL OVERHEAD STORAGE CHASSIS

PAINT CODES

P1

- ◆ Black P
- ◆ Brownstone P7D
- ◆ Charcoal S
- ◆ Designer White PJW
- ◆ Fossil P28
- ◆ Greige T5
- ◆ Light Gray Q
- ◆ Loft LOFT
- ◆ Muslin T3
- ◆ Putty L
- ◆ Shadow * SHDW
- ◆ Titanium P8T

P2

- ◆ Champagne Metallic T4
- ◆ Platinum Metallic T1
- ◆ Silver PR6
- ◆ Solar Black P8X

DUPLEX/PORTED TILE

PLASTIC CODES

- ◆ Black P
- ◆ Charcoal S
- ◆ Designer White DW
- ◆ Loft LOFT
- ◆ Muslin T3
- ◆ Titanium TI

Recommendations

Paint	Duplex-Data Code
Black P	Black P
Brownstone P7D	Brownstone EY
Charcoal S	Charcoal S
Designer White PJW	Designer White DW
Fossil P28	Charcoal S
Greige T5	Muslin T3
Light Gray Q	Loft LOFT
Loft LOFT	Loft LOFT
Muslin T3	Muslin T3
Putty L	Black P
Shadow SHDW	Muslin T3
Silver PR6	Titanium TI
Titanium P8T	Titanium TI
Champagne Metallic T4	Muslin T3
Platinum Metallic T1	Titanium TI

ABOUND® GALLERY PANELS OVERVIEW

GALLERY PANELS

Abound® Gallery Panels are an affordable, sleek way to incorporate laminate wing and end of run panels where power is not needed. The simplistic design provides a great new way to add woodgrains or solid laminate finishes to your workstation allowing for greater customization and value engineering.

BASIC CHARACTERISTICS

- Available in L-, T-, and Mid-configurations.
- Made of 1 1/8" board with high-pressure laminate.
- Use 1/8" thickness for space planning.
- Can be specified with matching or contrasting edge colors.
- Available in woodgrain and solid laminates.
- Woodgrain laminates can be specified with vertical grain on panels from 24" to 60"W.
- Horizontal grain available on all panel sizes.
- Gallery Panels offer 2 1/2" leveling capacity.
- Overall heights line up with adjacent panel.
- Available with and without integrated glass options (specified separately).
- Gallery Panels for use with glass have separate model numbers.
- All configurations are non-handed and secured using hidden fasteners.
- Standard Gallery Panels cannot connect to each other, you must use Gallery-to-Gallery Panels for connections.
- Additional support is required after every 60" in Gallery Panel width (i.e., storage or workstation tie-in).
- Gallery Panel widths are true to size.
- Please adhere to all standard systems specification guides.

GALLERY PANEL OFFERING

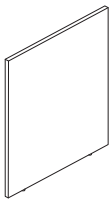

Wing End of Run
42"H, 50"H x 27", 33", 39", 45", 51", 63"W
Wing Middle of Run
42"H, 50"H x 24", 30", 36", 42", 48", 60"W
Spanning End of Run
42"H, 50"H x 51", 63", 75"W

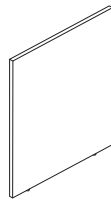

Wing End of Run, Accepts Glass
42"H, 50"H x 27", 33", 39", 45", 51", 63"W
Wing Middle, Accepts Glass
42"H, 50"H x 24", 30", 36", 42", 48", 60"W
Spanning End of Run, Accepts Glass
42"H, 50"H x 51", 63", 75"W

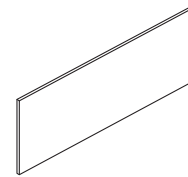

Wing End of Run, Accepts Glass
7 1/2"H x 27", 33", 39", 45", 51", 63"W
Wing Middle, Accepts Glass
7 1/2"H x 24", 30", 36", 42", 48", 60"W
Spanning End of Run, Accepts Glass
7 1/2"H x 51", 63", 75"W

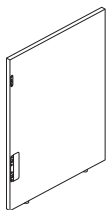

Gallery-to-Gallery, L-Connection
35"H, 42"H, 50"H x 18", 24", 30", 36", 42", 48", 60"W
Gallery-to-Gallery, L-Connection, Accepts Glass
35"H, 42"H, 50"H x 18", 24", 30", 36", 42", 48", 60"W

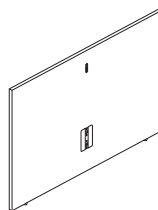

Gallery-to-Gallery, T-Connection
35"H, 42"H, 50"H x 18", 24", 30", 36", 42", 48", 60"W
Gallery-to-Gallery, T-Connection, Accepts Glass
35"H, 42"H, 50"H x 18", 24", 30", 36", 42", 48", 60"W

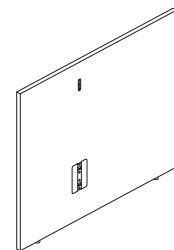

Gallery-to-Gallery, Non-Symmetrical Connection
35"H, 42"H, 50"H x 18", 24", 30"W
Gallery-to-Gallery, Non-Symmetrical, Accepts Glass
35"H, 42"H, 50"H x 18", 24", 30"W

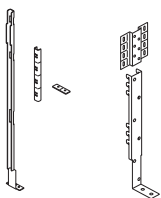

Gallery Panel Connectors
Spanning End of Run, L Connectors,
and Wing Middle Brackets



Gallery Connector
("Block and Trim" Kit)
For 35"-65"H Panels

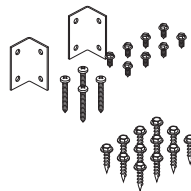

Gallery to Metal/Laminate Kits

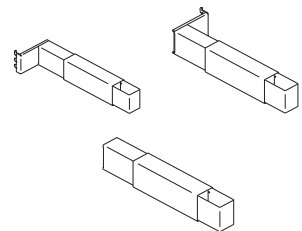

Height Adjustable Tie-In Brackets

ABOUND[®] GALLERY PANELS OVERVIEW

GALLERY PANELS DIMENSIONS

Gallery Panel Widths

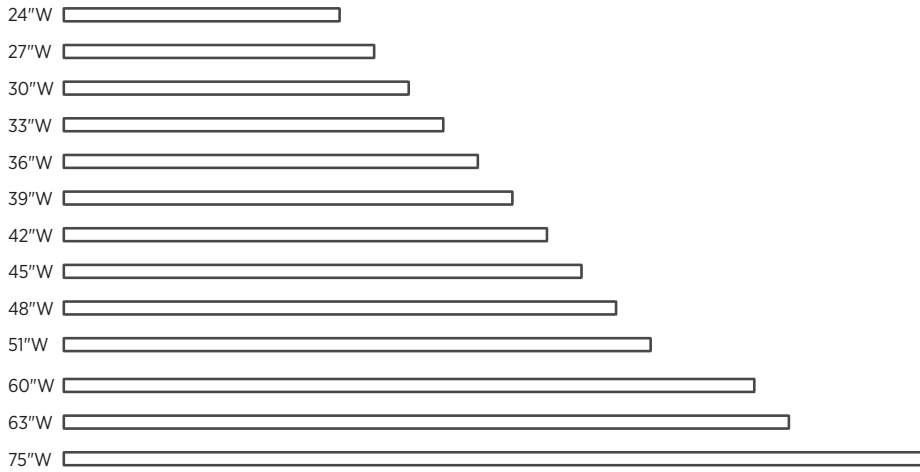

Gallery Panel Heights

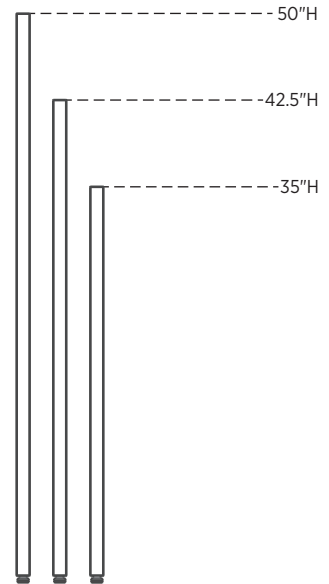

WORKING WITH INTEGRATED GLASS

- Gallery Panels for use with glass offer a routed top edge.
- Glass mounts directly into the Gallery Panel route via a gasket.
- The routing is inset 1½" from each end of the panel.
- Total glass width will be 3" narrower than the Gallery Panel.
- Glass height is available in 7½"H.
- Glass is available on all Gallery Panel widths.
- Specify glass models separate from Gallery Panel models.

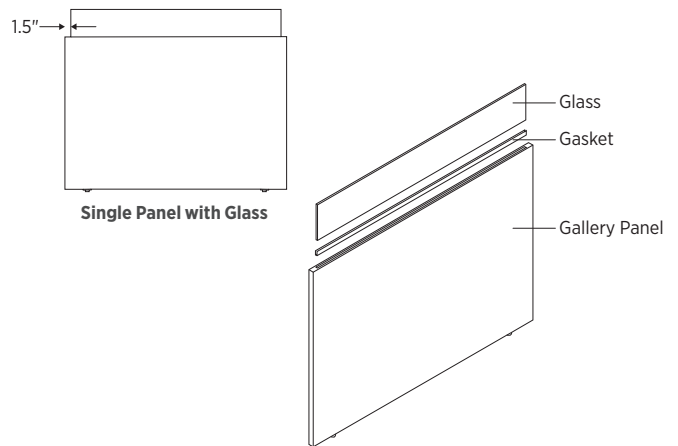

ABOUND® GALLERY PANELS OVERVIEW

T-CONFIGURATION

- Provides privacy to one or both ends of the Abound® system in a dual-sided application.
- All T-configurations connect using HRVCE connector kit.
- When the system panel is higher than the Gallery Panel, a variable height system's trim must be specified to finish off the exposed frame.
- T-configuration can be used for off-modular planning. The HRVCE connector kit location must be field measured.
- Accommodate for 2⁵/₈" frame thickness when planning with Abound® panel system.

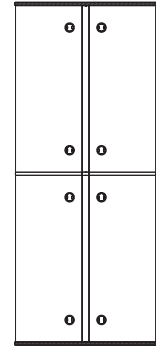
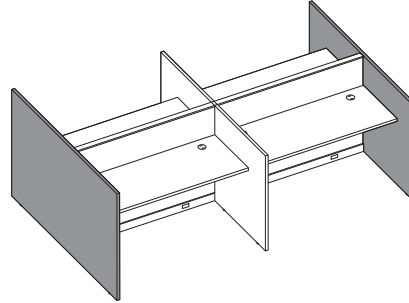

L-CONFIGURATION

- Provides privacy to one or both ends of the system in a single-sided application.
- L-configuration caps over the system panel.
- Due to the thickness of the Abound® panel L-configuration overhangs by approximately 3/16" on both sides.
- Accommodate for 2⁵/₈" frame thickness planning with Abound® panel system.
- All L-configuration Gallery Panels require the connector kit HRVCE to attach to the parent run.
- When the system panel is higher than the Gallery Panel, the variable height system's trim must be specified to finish off exposed frame.

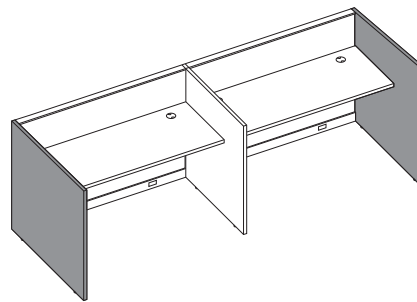

MID-CONFIGURATION (SINGLE-SIDED OR DUAL-SIDED)

- Mid-configuration panel does not overlap parent system panel.
- When specifying mid-configuration panels, one Gallery Panel "block and trim" kit (HRVCXXGP) is required to space the system panels out 1¹/₈". Kits include: Connector blocks, vertical trim, and a top cap.
- "Block and trim" models must match the height of the parent run.
- Specify one mid-connector kit (HRVCM) per Gallery Panel to attach to parent run. Gallery Panel and mid-connector kit attach over "block and trim" kit. Dual-sided application requires two connector kit models.
- When using a mid-configuration Gallery Panel, both panel frames in the spine must be of equal height.
- Mid-configuration Gallery Panel may not exceed the height of the parent run.
- Trims can be painted to match the system panel trims.

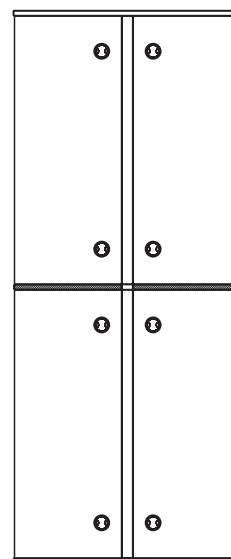

Dual-Sided Configuration

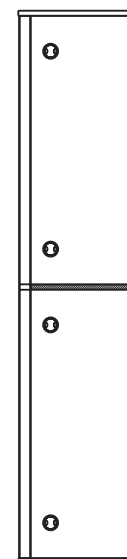

Single-Sided Configuration

ABOUT® GALLERY PANELS OVERVIEW

STORAGE AND WORKSURFACE CONNECTORS

- Use HRVGLSK to connect to laminate storage or HRVGMSK for metal storage.
- To connect to worksurfaces use HSTB2W1 bracket when used in perpendicular to parent run or use standard systems cantilever brackets when used in parallel to parent run in panel systems.

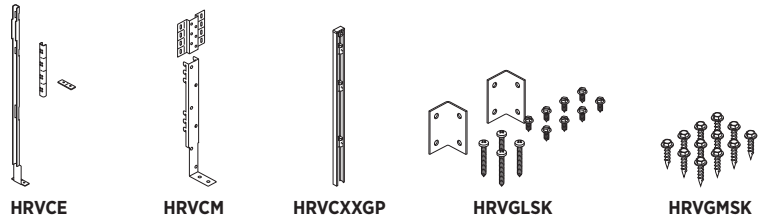

PANEL SYSTEMS

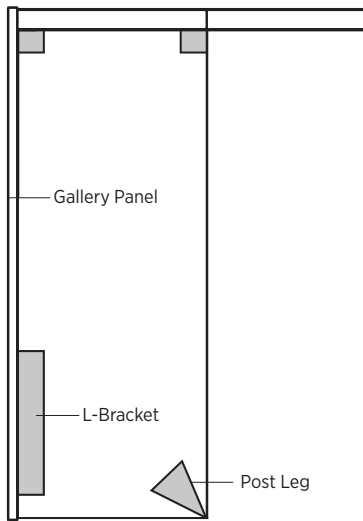

Perpendicular panel system with L-bracket (HSTB2W1) and post leg.

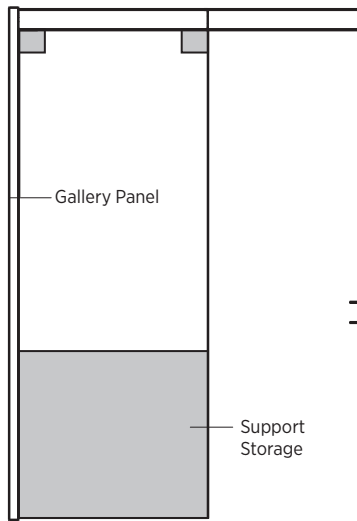

Perpendicular panel system with storage support.

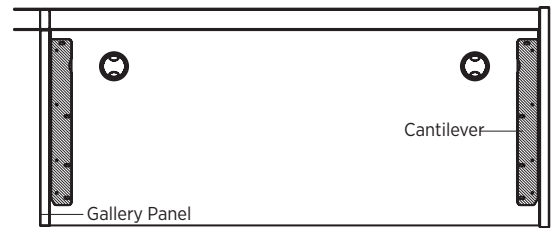

Panel system with cantilever support.

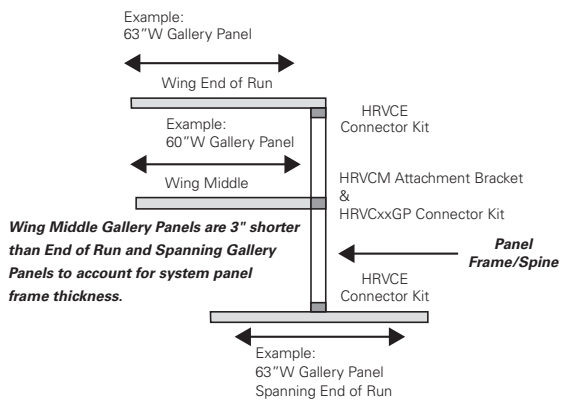

ABOUND[®] GALLERY PANELS OVERVIEW

GALLERY-TO-GALLERY PANELS

- Gallery-to-Gallery Panels connect to other Gallery Panels and are available in L-, T-, and Non-symmetrical T-configurations.
- When specifying Gallery-to-Gallery Panels, the installation template HHALGPT is required. The recommendation is one template for every 30 panels.
- Gallery-to-Gallery Panels must be of equal or lower height than the Standard Gallery Panel attached. The Gallery-to-Gallery Panel cannot be taller than the adjacent panel. If this is needed, please reach out to Tailored Solutions for a custom solution.
- Made of 1 $\frac{1}{8}$ " board with HPL laminate.
- Can be specified with matching or contrasting edge.
- Edgeband is 2mm ABS.
- Available in woodgrain and solid laminates.
- Woodgrain laminates can be specified with vertical grain up to 60"W.
- Gallery-to-Gallery Panel widths are available in 18", 24", 30", 36", 42", 48", and 60"W.
- Gallery Panels offer 2 $\frac{1}{2}$ " leveling capability.
- Overall heights line up with adjacent panel.
- Gallery-to-Gallery Panels cap over Standard Gallery Panels and are oversized by 1 $\frac{1}{8}$ " to maintain true interior dimensions.
- Available with or without the integrated glass option.
- Glass is specified separately.
- Gallery Panels for use with glass have separate model numbers.
- Gallery-to-Gallery Panels are secured with an inset flat bracket under a painted metal cover.
- L-panels are non-handed.
- Non-symmetrical T-panels vary in size on either side of the adjacent panel.
- Please adhere to all standard systems specification guidelines.
- Additional support is required after every 60" in Gallery Panel width (i.e., a storage or worksurface tie-in).

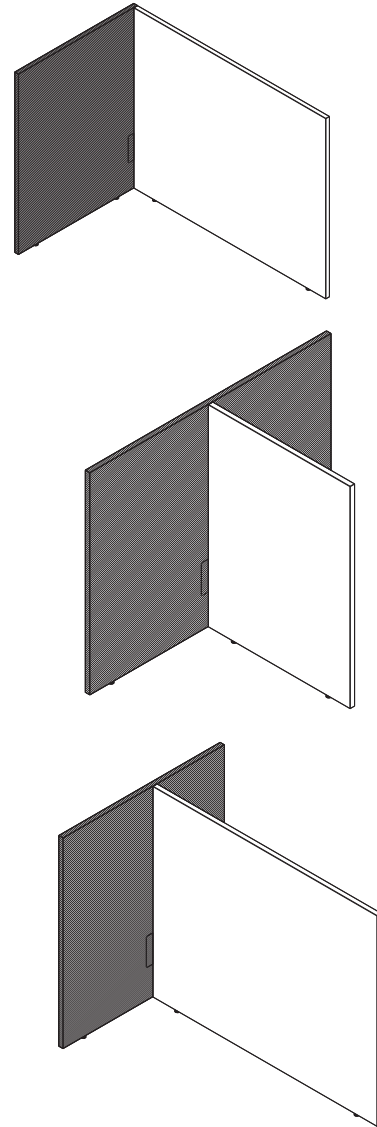

ABOUT® GALLERY PANELS OVERVIEW

GALLERY-TO-GALLERY FREESTANDING SCREENS

Freestanding screens can be created using Standard Gallery Panels and Gallery-to-Gallery Panels. All Gallery Panel heights are allowed.

Freestanding L-Screens

Parent	Minimum Return
30"-36"	30"
>36"-60"	36"

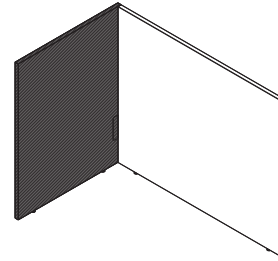
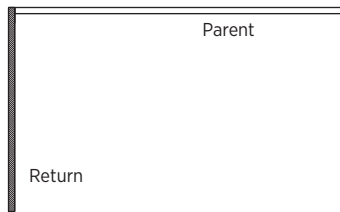

Freestanding U-Screens

Parent	Minimum Return
24"-60"	24"

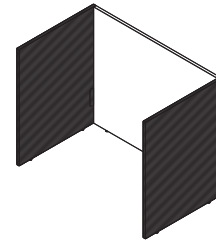
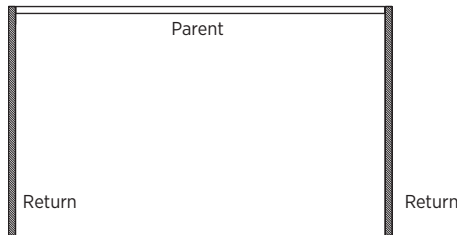

Freestanding T-Screens

Parent	Minimum Return
30"-36"	30"
>36"-60"	36"
>60"-72"	42"

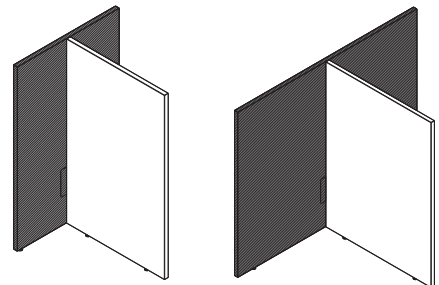

Freestanding H-Screens

Freestanding T (Dual-Sided)	
Parent	Minimum Return
30"-60"	18"

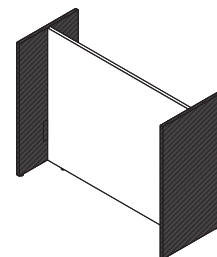
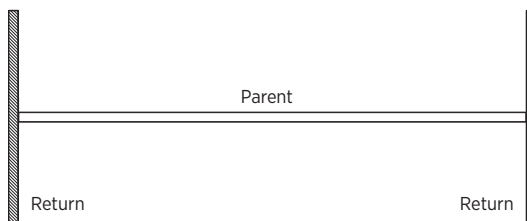

NOTES: Increase minimum return length by 3" or next largest width of panel for every 7½" variation in panel height.

ABOUND[®] Gallery Panels — Wing

OPEN MARKET



Icon Legend on page 19

WORKSTATIONS

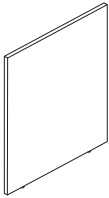

DESCRIPTION	MODEL	SHIP WEIGHT	CUBE	LIST PRICE BY LAMINATE GRADE	
				L1	L2
Wing End of Run or Spanning End of Run					
35"H x 27"W	HRVG3527L	30.1	2.5	\$348	\$365
35"H x 33"W	HRVG3533L	36.8	3.0	\$423	\$444
35"H x 39"W	HRVG3539L	43.6	3.6	\$479	\$503
35"H x 45"W	HRVG3545L	50.3	4.1	\$532	\$559
35"H x 51"W	HRVG3551L	57.0	4.6	\$573	\$602
35"H x 63"W	HRVG3563L	70.4	5.7	\$652	\$683
35"H x 75"W	HRVG3575L	83.8	6.7	\$794	\$734
42"H x 27"W	HRVG4227L	42.5	2.9	\$382	\$401
42"H x 33"W	HRVG4233L	50.0	3.6	\$464	\$487
42"H x 39"W	HRVG4239L	58.0	4.2	\$527	\$553
42"H x 45"W	HRVG4245L	65.0	4.8	\$569	\$597
42"H x 51"W	HRVG4251L	73.5	5.4	\$630	\$661
42"H x 63"W	HRVG4263L	89.0	6.7	\$708	\$743
42"H x 75"W	HRVG4275L	104.5	7.9	\$817	\$858
50"H x 27"W	HRVG5027L	49.0	3.5	\$439	\$461
50"H x 33"W	HRVG5033L	58.0	4.2	\$514	\$540
50"H x 39"W	HRVG5039L	67.5	4.9	\$574	\$603
50"H x 45"W	HRVG5045L	77.0	5.6	\$649	\$681
50"H x 51"W	HRVG5051L	86.0	6.4	\$683	\$717
50"H x 63"W	HRVG5063L	104.5	7.8	\$767	\$805
50"H x 75"W	HRVG5075L	123.0	9.3	\$889	\$933

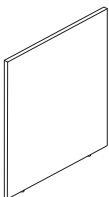

Wing Middle					
35"H x 24"W	HRVG3524L	26.8	2.4	\$330	\$346
35"H x 30"W	HRVG3530L	33.5	2.9	\$402	\$422
35"H x 36"W	HRVG3536L	40.2	3.3	\$448	\$470
35"H x 42"W	HRVG3542L	46.9	3.8	\$501	\$526
35"H x 48"W	HRVG3548L	53.6	4.4	\$554	\$582
35"H x 60"W	HRVG3560L	67.0	5.4	\$638	\$670
42"H x 24"W	HRVG4224L	38.5	2.6	\$362	\$380
42"H x 30"W	HRVG4230L	46.0	3.3	\$441	\$463
42"H x 36"W	HRVG4236L	54.0	3.9	\$492	\$517
42"H x 42"W	HRVG4242L	62.0	4.5	\$550	\$577
42"H x 48"W	HRVG4248L	69.5	5.1	\$592	\$622
42"H x 60"W	HRVG4260L	85.0	6.3	\$690	\$724
50"H x 24"W	HRVG5024L	44.5	3.1	\$417	\$438
50"H x 30"W	HRVG5030L	53.0	3.8	\$490	\$514
50"H x 36"W	HRVG5036L	63.0	4.6	\$541	\$568
50"H x 42"W	HRVG5042L	72.0	5.3	\$605	\$635
50"H x 48"W	HRVG5048L	81.5	6.0	\$666	\$699
50"H x 60"W	HRVG5060L	100.0	7.5	\$752	\$790

NOTES:

- When specifying Wing End of Run panels, the Gallery Panels are 3" wider to allow for the panel to cover the width of the spine.
- Mid-configuration creates 1/8" space between the system panels. This gap matches the thickness of the Gallery Panel.
- Wing End of Run widths of 51", 63", and 75"W can be used as spanning end of run configurations.
- Gallery Panels come standard with two adjustable leveling guides.
- Gallery Panels require connectors to attach to the spine of the panel. See connectors on page 437.
- Gallery Panels up to 60"W can specify vertical or horizontal woodgrain direction. Panels larger than 60"W will have horizontal woodgrain.

- ❗ Minimum panel length must be 50% of the Gallery Panel for stability.
- ❗ When system panel is higher than the Gallery Panel, system's variable height trim kit must be specified to finish off the exposed frame.
- ❗ Gallery Panels can only connect to standard panel frames; Gallery Panels cannot connect to each other.
- ❗ Gallery Panels longer than 60" require a floor or storage support.

HOW TO SPECIFY

<p>Select Model Number</p> <p>HRVG3527L</p>	<p>Select Laminate</p> <p>See page 391</p> <p>C</p>	<p>Select Edge</p> <p>See page 391</p> <p>C</p>	<p>Select Grain Direction</p> <p>VST Vertical Grain (not available on 63"W or wider) VLG Horizontal Grain and Solid Laminate only</p> <p>VST</p>	<p>Select Glide</p> <p>G Glide</p> <p>G</p>
--	--	--	---	--



Gallery Panels — Wing, Accepts Glass

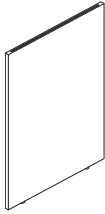

DESCRIPTION	MODEL	SHIP WEIGHT	CUBE	LIST PRICE BY LAMINATE GRADE	
				L1	L2
Wing End of Run or Spanning End of Run, Accepts Glass					
35”H x 27”W	HRVG3527LG	30.1	2.5	\$473	\$497
35”H x 33”W	HRVG3533LG	36.8	3.0	\$548	\$575
35”H x 39”W	HRVG3539LG	43.6	3.6	\$605	\$635
35”H x 45”W	HRVG3545LG	50.3	4.1	\$657	\$690
35”H x 51”W	HRVG3551LG	57.0	4.6	\$698	\$733
35”H x 63”W	HRVG3563LG	70.4	5.7	\$779	\$818
35”H x 75”W	HRVG3575LG	83.8	6.7	\$915	\$961
42”H x 27”W	HRVG4227LG	42.5	2.9	\$508	\$533
42”H x 33”W	HRVG4233LG	50.0	3.6	\$590	\$619
42”H x 39”W	HRVG4239LG	58.0	4.2	\$652	\$685
42”H x 45”W	HRVG4245LG	66.0	4.8	\$695	\$730
42”H x 51”W	HRVG4251LG	73.5	5.4	\$755	\$793
42”H x 63”W	HRVG4263LG	89.0	6.7	\$834	\$876
42”H x 75”W	HRVG4275LG	104.5	7.9	\$942	\$989
50”H x 27”W	HRVG5027LG	49.0	3.5	\$564	\$592
50”H x 33”W	HRVG5033LG	58.0	4.2	\$640	\$672
50”H x 39”W	HRVG5039LG	67.5	4.9	\$699	\$734
50”H x 45”W	HRVG5045LG	77.0	5.6	\$774	\$813
50”H x 51”W	HRVG5051LG	86.0	6.4	\$808	\$848
50”H x 63”W	HRVG5063LG	104.5	7.8	\$893	\$938
50”H x 75”W	HRVG5075LG	123.0	9.3	\$1015	\$1066

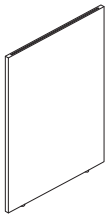

Wing Middle, Accepts Glass					
35”H x 24”W	HRVG3524LG	26.8	2.4	\$455	\$478
35”H x 30”W	HRVG3530LG	33.5	2.9	\$527	\$553
35”H x 36”W	HRVG3536LG	40.2	3.3	\$574	\$603
35”H x 42”W	HRVG3542LG	46.9	3.8	\$626	\$657
35”H x 48”W	HRVG3548LG	53.6	4.4	\$679	\$713
35”H x 60”W	HRVG3560LG	67.0	5.4	\$765	\$803
42”H x 24”W	HRVG4224LG	38.5	2.6	\$487	\$511
42”H x 30”W	HRVG4230LG	46.0	3.3	\$567	\$595
42”H x 36”W	HRVG4236LG	54.0	3.9	\$618	\$649
42”H x 42”W	HRVG4242LG	62.0	4.5	\$675	\$709
42”H x 48”W	HRVG4248LG	69.5	5.1	\$717	\$753
42”H x 60”W	HRVG4260LG	85.0	6.3	\$815	\$856
50”H x 24”W	HRVG5024LG	44.5	3.1	\$542	\$569
50”H x 30”W	HRVG5030LG	54.0	3.8	\$615	\$646
50”H x 36”W	HRVG5036LG	63.0	4.6	\$667	\$700
50”H x 42”W	HRVG5042LG	72.0	5.3	\$731	\$768
50”H x 48”W	HRVG5048LG	81.5	6.0	\$774	\$814
50”H x 60”W	HRVG5060LG	100.0	7.5	\$877	\$921

NOTES:

- When specifying Wing End of Run panels, the Gallery Panels are 3” wider to allow for the panel to cover the width of the spine.
- Mid-configuration creates 1/8” space between the system panels. This gap matches the thickness of the Gallery Panel.
- Wing End of Run widths of 51”, 63”, and 75”W can be used as spanning end of run configurations.
- Gallery Panels come standard with two adjustable leveling guides.
- Gallery Panels require connectors to attach to the spine of the panel. See connectors on page 437.
- Gallery Panels up to 60”W can specify vertical or horizontal woodgrain direction. Panels larger than 60”W will have horizontal woodgrain.
- ! Minimum panel length must be 50% of the Gallery Panel for stability.
- ! When system panel is higher than the Gallery Panel, system’s variable height trim kit must be specified to finish off the exposed frame.
- ! Gallery Panels can only connect to standard panel frames; Gallery Panels cannot connect to each other.

HOW TO SPECIFY

<p>Select Model Number</p> <p>HRVG3527LG</p>	<p>Select Laminate</p> <p>See page 391</p> <p>C</p>	<p>Select Edge</p> <p>See page 391</p> <p>C</p>	<p>Select Grain Direction</p> <p>VST Vertical Grain (not available on 63”W or wider) VLG Horizontal Grain and Solid Laminate only</p> <p>VST</p>	<p>Select Glide</p> <p>G Glide</p> <p>G</p>
---	--	--	---	--

ABOUND[®] Gallery Glass

OPEN MARKET



Icon Legend on page 19

WORKSTATIONS

	DESCRIPTION	MODEL	SHIP WEIGHT	CUBE	CLEAR GLASS	FROSTED GLASS
	7 1/2" H Gallery Glass, Wing, End of Run					
	For 27"D Panels	SPLH-ABND-GALGLSS.M482172	9.0	0.7	\$374	\$409
	For 33"D Panels	SPLH-ABND-GALGLSS.M482174	10.5	0.9	\$396	\$431
	For 39"D Panels	SPLH-ABND-GALGLSS.M482176	12.0	1.1	\$453	\$488
	For 45"D Panels	SPLH-ABND-GALGLSS.M482178	13.0	1.3	\$479	\$514
	For 51"D Panels	SPLH-ABND-GALGLSS.M482180	14.5	1.5	\$529	\$564
	7 1/2" H Gallery Glass, Middle					
	For 24"D Panels	SPLH-ABND-GALGLSS.M482171	8.0	0.7	\$365	\$400
	For 30"D Panels	SPLH-ABND-GALGLSS.M482173	10.0	0.8	\$385	\$420
	For 36"D Panels	SPLH-ABND-GALGLSS.M482175	11.0	1.0	\$405	\$440
	For 42"D Panels	SPLH-ABND-GALGLSS.M482177	12.5	1.2	\$465	\$500
	For 48"D Panels	SPLH-ABND-GALGLSS.M482179	14.0	1.4	\$509	\$544
	7 1/2" H Gallery Glass, Spanning End of Run					
	For 51"D Panels	SPLH-ABND-GALGLSS.M482180	14.5	1.5	\$529	\$564
	For 63"D Panels	SPLH-ABND-GALGLSS.M482182	17.0	1.8	\$622	\$657
	For 75"D Panels	SPLH-ABND-GALGLSS.M482183	19.5	2.2	\$735	\$770

NOTES:

- Gallery Panels are 3" wider than corresponding glass to allow for proper fit and function.
- Glass is inset 1/2" from end of Gallery Panel.
- ! Cannot hang or stack on top of Frameless Glass.
- ! Frameless Glass can only be used on the top of Gallery Panels. Glass integrates into notch cutout in the top of the panel.

HOW TO SPECIFY

<p>Select Model Number</p> <p>S P L H - A B N D - G A L G L S S . M 4 8 2 1 7 1 .</p>	<p>Select Glass</p> <p>Q Clear Glass R Frosted Glass</p> <p>Q</p>
---	---

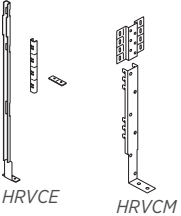

ABOUND[®] Gallery Connector Kits

	DESCRIPTION	MODEL	SHIP WEIGHT	CUBE	LIST PRICE BY PAINT GRADE	
					P1	P2
	Gallery Panel Connectors					
	Spanning End of Run and L Connector	HRVCE	0.83	0.1	\$75	\$82
	Wing Middle Attachment Brackets	HRVCM	0.62	0.1	\$86	\$95

	Gallery Connector Kits					
	35"	HRVC35GP	1.0	0.3	\$170	\$183
	42"	HRVC42GP	1.5	0.4	\$190	\$205
	50"	HRVC50GP	1.5	0.5	\$200	\$215
	65"	HRVC65GP	2.0	0.6	\$232	\$249

	DESCRIPTION	MODEL	SHIP WEIGHT	CUBE	LIST PRICE
	Gallery Panel-to-Storage Kits				
	Laminate Storage Ganging Kit	HRVGLSK	0.1	0.1	\$41
	Metal Storage Ganging Kit	HRVGMSK	0.1	0.1	\$9

NOTES:

- HRVCE is used in L and spanning (T) end of run applications.
- Wing Middle Connector Kits accommodate both single-sided and dual-sided applications.
- For more rigidity, the Gallery Panel can be tied to a storage or a non-adjustable surface. Use HRVGLSK for laminate or HRVGMSK for metal storage.
- ❗ Wing Middle Connector Kits must be used in any Wing Middle application in conjunction with model HRVCM.
- ❗ Wing Middle Connector Kits are required for Wing Middle applications and are used only with Wing Middle Gallery Panels.
- ❗ Gallery Panels can only connect to standard panel frames; Gallery Panels cannot connect to each other.
- ❗ See Gallery Panel and Connector illustration on pages 434 and 435 for placement and application.

HOW TO SPECIFY

<p>Select Model Number</p> <p>HRVC42GP</p>	<p>Select Paint Color</p> <p>See page 391</p> <p>T1</p>
--	---

<p>Select Model Number</p> <p>HRVGMSK</p>

ABOUND[®] Gallery Panel

OPEN MARKET



Icon Legend on page 19

WORKSTATIONS

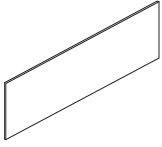

DESCRIPTION	MODEL	SHIP WEIGHT	CUBE	LIST PRICE BY FABRIC GRADE							
				AA	A	B	C	D	E	F	G
Gallery Panel 36"W x 11"H 36"W x 18½"H	HRVTB11	7	1.1	\$254	\$259	\$262	\$265	\$268	\$273	\$278	\$283
	HRVTB18	10	1.8	\$298	\$303	\$306	\$309	\$312	\$317	\$322	\$327

NOTES:

- attaches to Gallery Panel by screwing painted metal frame onto Gallery Panel surface. Fabric insert attaches to painted metal frame with hook and loop.
- Attachment hardware for is provided.
- ! No template is provided for placement and leveling of .

HOW TO SPECIFY

Select Model Number	Select Fabric
	See pages 392-393
HRVTB11	APN11



Icon Legend on page 19

ABOUTD® Gallery-to-Gallery Connections

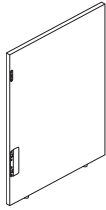

DESCRIPTION	MODEL	SHIP WEIGHT	CUBE	LIST PRICE BY LAMINATE GRADE	
				L1	L2
L-Connections, Right Hand					
35"H x 18"W	HRVG3518GGR	23.6	2.0	\$548	\$573
35"H x 24"W	HRVG3524GGR	30.5	2.6	\$591	\$618
35"H x 30"W	HRVG3530GGR	37.4	3.1	\$638	\$667
35"H x 36"W	HRVG3536GGR	44.3	3.6	\$684	\$715
35"H x 42"W	HRVG3542GGR	51.1	4.1	\$735	\$769
35"H x 48"W	HRVG3548GGR	58.0	4.7	\$789	\$826
35"H x 60"W	HRVG3560GGR	71.8	5.7	\$848	\$888
42"H x 18"W	HRVG4218GGR	28.5	2.4	\$569	\$595
42"H x 24"W	HRVG4224GGR	36.9	3.0	\$614	\$642
42"H x 30"W	HRVG4230GGR	45.3	3.7	\$662	\$692
42"H x 36"W	HRVG4236GGR	53.7	4.3	\$715	\$748
42"H x 42"W	HRVG4242GGR	62.1	4.9	\$773	\$809
42"H x 48"W	HRVG4248GGR	70.5	5.6	\$835	\$874
42"H x 60"W	HRVG4260GGR	87.3	6.8	\$897	\$939
50"H x 18"W	HRVG5018GGR	33.4	2.8	\$614	\$642
50"H x 24"W	HRVG5024GGR	43.3	3.5	\$662	\$692
50"H x 30"W	HRVG5030GGR	53.2	4.3	\$715	\$748
50"H x 36"W	HRVG5036GGR	63.1	5.0	\$768	\$804
50"H x 42"W	HRVG5042GGR	73.1	5.7	\$825	\$863
50"H x 48"W	HRVG5048GGR	83.0	6.5	\$886	\$928
50"H x 60"W	HRVG5060GGR	102.8	7.9	\$953	\$998

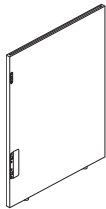

DESCRIPTION	MODEL	SHIP WEIGHT	CUBE	LIST PRICE BY LAMINATE GRADE	
				L1	L2
L-Connections, Right Hand, Accepts Glass					
35"H x 18"W	HRVG3518GGRG	23.6	2.0	\$633	\$662
35"H x 24"W	HRVG3524GGRG	30.5	2.6	\$683	\$714
35"H x 30"W	HRVG3530GGRG	37.4	3.1	\$738	\$772
35"H x 36"W	HRVG3536GGRG	44.3	3.6	\$793	\$830
35"H x 42"W	HRVG3542GGRG	51.1	4.1	\$852	\$892
35"H x 48"W	HRVG3548GGRG	58.0	4.7	\$915	\$958
35"H x 60"W	HRVG3560GGRG	71.8	5.7	\$984	\$1030
42"H x 18"W	HRVG4218GGRG	28.4	2.4	\$648	\$678
42"H x 24"W	HRVG4224GGRG	36.9	3.0	\$700	\$732
42"H x 30"W	HRVG4230GGRG	45.3	3.7	\$756	\$791
42"H x 36"W	HRVG4236GGRG	53.7	4.3	\$817	\$855
42"H x 42"W	HRVG4242GGRG	62.1	4.9	\$883	\$924
42"H x 48"W	HRVG4248GGRG	70.5	5.6	\$955	\$1000
42"H x 60"W	HRVG4260GGRG	87.3	6.8	\$1027	\$1076
50"H x 18"W	HRVG5018GGRG	33.4	2.8	\$683	\$714
50"H x 24"W	HRVG5024GGRG	43.3	3.5	\$738	\$772
50"H x 30"W	HRVG5030GGRG	53.2	4.3	\$797	\$834
50"H x 36"W	HRVG5036GGRG	63.1	5.0	\$856	\$896
50"H x 42"W	HRVG5042GGRG	73.1	5.7	\$920	\$963
50"H x 48"W	HRVG5048GGRG	83.0	6.5	\$990	\$1037
50"H x 60"W	HRVG5060GGRG	102.8	7.9	\$1064	\$1114

NOTES:

- Gallery-to-Gallery Panels connect to other Gallery Panels and are available in L-, T-, and Non-symmetrical T-configurations.
- When specifying Gallery-to-Gallery Panels, the installation template (HHALGPT) is required. The recommendation is one template for every 30 panels. Templates are reusable.
- Gallery-to-Gallery Panels must be of equal or lower height than the Standard Gallery Panel attached. The Gallery-to-Gallery Panel cannot be taller than the adjacent panel. If this is needed, please reach out to Tailored Solutions for a custom solution.
- Made of 1 1/8" board with HPL laminate.
- Can be specified with matching or contrasting edge.
- Edgeband is 2mm ABS.
- Available in woodgrain and solid laminates.
- Woodgrain laminates can be specified with vertical grain up to 60"W. Horizontal grain is available on all sizes.
- Gallery-to-Gallery Panel widths are available in 18", 24", 30", 36", 42", 48", and 60"W.
- Gallery Panels offer 2 1/2" leveling capability.
- Overall heights line up with adjacent panel.
- Gallery-to-Gallery Panels cap over Standard Gallery Panels and are oversized by 1/8" to maintain true interior dimensions.
- Available with or without the integrated glass option.
- Glass is specified separately.
- Gallery Panels for use with glass have separate model numbers.
- Gallery-to-Gallery Panels are secured with an inset flat bracket under a painted metal cover.
- L-panels are non-handed.

HOW TO SPECIFY

<p>Select Model Number</p> <p>HRVG4236GGR</p>	<p>Select Laminate</p> <p>See page 391</p> <p>H</p>	<p>Select Edge</p> <p>See page 391</p> <p>H</p>	<p>Select Grain Direction</p> <p>VLG Horizontal Grain and Solid Laminate only VST Vertical Grain</p> <p>VLG</p>	<p>Select Glide</p> <p>G Glide</p> <p>G</p>
--	--	--	--	--

ABOUND[®] Gallery-to-Gallery Connections

OPEN MARKET



Icon Legend on page 19

WORKSTATIONS

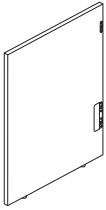

DESCRIPTION	MODEL	SHIP WEIGHT	CUBE	LIST PRICE BY LAMINATE GRADE	
				L1	L2
L-Connections, Left Hand					
35"H x 18"W	HRVG3518GGGL	23.6	2.0	\$548	\$573
35"H x 24"W	HRVG3524GGGL	30.5	2.6	\$591	\$618
35"H x 30"W	HRVG3530GGGL	37.4	3.1	\$638	\$667
35"H x 36"W	HRVG3536GGGL	44.3	3.6	\$684	\$715
35"H x 42"W	HRVG3542GGGL	51.1	4.1	\$735	\$769
35"H x 48"W	HRVG3548GGGL	58.0	4.7	\$789	\$826
35"H x 60"W	HRVG3560GGGL	71.8	5.7	\$848	\$888
42"H x 18"W	HRVG4218GGGL	28.5	2.4	\$569	\$595
42"H x 24"W	HRVG4224GGGL	36.9	3.0	\$614	\$642
42"H x 30"W	HRVG4230GGGL	45.3	3.7	\$662	\$692
42"H x 36"W	HRVG4236GGGL	53.7	4.3	\$715	\$748
42"H x 42"W	HRVG4242GGGL	62.1	4.9	\$773	\$809
42"H x 48"W	HRVG4248GGGL	70.5	5.6	\$835	\$874
42"H x 60"W	HRVG4260GGGL	87.3	6.8	\$897	\$939
50"H x 18"W	HRVG5018GGGL	33.4	2.8	\$614	\$642
50"H x 24"W	HRVG5024GGGL	43.3	3.5	\$662	\$692
50"H x 30"W	HRVG5030GGGL	53.2	4.3	\$715	\$748
50"H x 36"W	HRVG5036GGGL	63.1	5.0	\$768	\$804
50"H x 42"W	HRVG5042GGGL	73.1	5.7	\$825	\$863
50"H x 48"W	HRVG5048GGGL	83.0	6.5	\$886	\$928
50"H x 60"W	HRVG5060GGGL	102.8	7.9	\$953	\$998



L-Connections, Left Hand, Accepts Glass					
35"H x 18"W	HRVG3518GGGLG	23.6	2.0	\$633	\$662
35"H x 24"W	HRVG3524GGGLG	30.5	2.6	\$683	\$714
35"H x 30"W	HRVG3530GGGLG	37.4	3.1	\$738	\$772
35"H x 36"W	HRVG3536GGGLG	44.3	3.6	\$793	\$830
35"H x 42"W	HRVG3542GGGLG	51.1	4.1	\$852	\$892
35"H x 48"W	HRVG3548GGGLG	58.0	4.7	\$915	\$958
35"H x 60"W	HRVG3560GGGLG	71.8	5.7	\$984	\$1030
42"H x 18"W	HRVG4218GGGLG	28.4	2.4	\$648	\$678
42"H x 24"W	HRVG4224GGGLG	36.9	3.0	\$700	\$732
42"H x 30"W	HRVG4230GGGLG	45.3	3.7	\$756	\$791
42"H x 36"W	HRVG4236GGGLG	53.7	4.3	\$817	\$855
42"H x 42"W	HRVG4242GGGLG	62.1	4.9	\$883	\$924
42"H x 48"W	HRVG4248GGGLG	70.5	5.6	\$955	\$1000
42"H x 60"W	HRVG4260GGGLG	87.3	6.8	\$1027	\$1076
50"H x 18"W	HRVG5018GGGLG	33.4	2.8	\$683	\$714
50"H x 24"W	HRVG5024GGGLG	43.3	3.5	\$738	\$772
50"H x 30"W	HRVG5030GGGLG	53.2	4.3	\$797	\$834
50"H x 36"W	HRVG5036GGGLG	63.1	5.0	\$856	\$896
50"H x 42"W	HRVG5042GGGLG	73.1	5.7	\$920	\$963
50"H x 48"W	HRVG5048GGGLG	83.0	6.5	\$990	\$1037
50"H x 60"W	HRVG5060GGGLG	102.8	7.9	\$1064	\$1114

NOTES:

- Gallery-to-Gallery Panels connect to other Gallery Panels and are available in L-, T-, and Non-symmetrical T-configurations.
- When specifying Gallery-to-Gallery Panels, the installation template (HHALGPT) is required. The recommendation is one template for every 30 panels. Templates are reusable.
- Gallery-to-Gallery Panels must be of equal or lower height than the Standard Gallery Panel attached. The Gallery-to-Gallery Panel cannot be taller than the adjacent panel. If this is needed, please reach out to Tailored Solutions for a custom solution.
- Made of 1/8" board with HPL laminate.
- Can be specified with matching or contrasting edge.
- Edgeband is 2mm ABS.
- Available in woodgrain and solid laminates.
- Woodgrain laminates can be specified with vertical grain up to 60"W. Horizontal grain is available on all sizes.
- Gallery-to-Gallery Panel widths are available in 18", 24", 30", 36", 42", 48", and 60"W.
- Gallery Panels offer 2 1/2" leveling capability.
- Overall heights line up with adjacent panel.
- Gallery-to-Gallery Panels cap over Standard Gallery Panels and are oversized by 1/8" to maintain true interior dimensions.
- Available with or without the integrated glass option.
- Glass is specified separately.
- Gallery Panels for use with glass have separate model numbers.
- Gallery-to-Gallery Panels are secured with an inset flat bracket under a painted metal cover.
- L-panels are non-handed.

HOW TO SPECIFY

<p>Select Model Number</p> <p>HRVG4236GGGLG</p>	<p>Select Laminate</p> <p>See page 391</p> <p>H</p>	<p>Select Edge</p> <p>See page 391</p> <p>H</p>	<p>Select Grain Direction</p> <p>VLG Horizontal Grain and Solid Laminate only VST Vertical Grain</p> <p>VLG</p>	<p>Select Glide</p> <p>G Glide</p> <p>G</p>
--	--	--	--	--



Icon Legend on page 19

ABOUT® Gallery-to-Gallery Connections

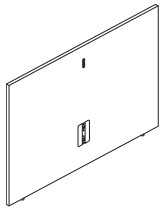

DESCRIPTION

T-Connections

35”H x 18”W
35”H x 36”W
35”H x 42”W
35”H x 48”W
35”H x 60”W
35”H x 72”W

42”H x 18”W
42”H x 36”W
42”H x 42”W
42”H x 48”W
42”H x 60”W
42”H x 72”W

50”H x 18”W
50”H x 36”W
50”H x 42”W
50”H x 48”W
50”H x 60”W
50”H x 72”W

MODEL

HRVG3518GGT
HRVG3536GGT
HRVG3542GGT
HRVG3548GGT
HRVG3560GGT
HRVG3572GGT

HRVG4218GGT
HRVG4236GGT
HRVG4242GGT
HRVG4248GGT
HRVG4260GGT
HRVG4272GGT

HRVG5018GGT
HRVG5036GGT
HRVG5042GGT
HRVG5048GGT
HRVG5060GGT
HRVG5072GGT

SHIP WEIGHT

CUBE

LIST PRICE BY LAMINATE GRADE

L1

L2

23.6 2.0 \$628 \$654
44.3 3.6 \$771 \$804
51.1 4.1 \$824 \$860
58.0 4.7 \$881 \$920
71.8 5.7 \$942 \$984
85.5 6.8 \$1018 \$1063

28.5 2.4 \$650 \$677
53.7 4.3 \$803 \$838
62.1 4.9 \$863 \$901
70.5 5.6 \$929 \$970
87.3 6.8 \$995 \$1039
104.1 8.1 \$1088 \$1137

33.4 2.8 \$697 \$726
63.1 5.0 \$861 \$899
73.1 5.7 \$926 \$967
83.0 6.5 \$997 \$1041
102.8 7.9 \$1074 \$1122
122.7 9.4 \$1158 \$1210

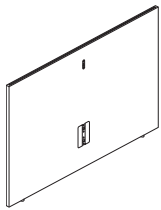

T-Connections, Accepts Glass

35”H x 18”W
35”H x 36”W
35”H x 42”W
35”H x 48”W
35”H x 60”W
35”H x 72”W

42”H x 18”W
42”H x 36”W
42”H x 42”W
42”H x 48”W
42”H x 60”W
42”H x 72”W

50”H x 18”W
50”H x 36”W
50”H x 42”W
50”H x 48”W
50”H x 60”W
50”H x 72”W

HRVG3518GGTG
HRVG3536GGTG
HRVG3542GGTG
HRVG3548GGTG
HRVG3560GGTG
HRVG3572GGTG

HRVG4218GGTG
HRVG4236GGTG
HRVG4242GGTG
HRVG4248GGTG
HRVG4260GGTG
HRVG4272GGTG

HRVG5018GGTG
HRVG5036GGTG
HRVG5042GGTG
HRVG5048GGTG
HRVG5060GGTG
HRVG5072GGTG

23.6 2.0 \$717 \$747
44.3 3.6 \$885 \$924
51.1 4.1 \$946 \$988
58.0 4.7 \$1013 \$1058
71.8 5.7 \$1086 \$1135
85.5 6.8 \$1164 \$1217

28.5 2.4 \$733 \$764
53.7 4.3 \$910 \$950
62.1 4.9 \$979 \$1022
70.5 5.6 \$1055 \$1102
87.3 6.8 \$1131 \$1181
104.1 8.1 \$1224 \$1280

33.4 2.8 \$769 \$802
63.1 5.0 \$958 \$1000
73.1 5.7 \$1032 \$1078
83.0 6.5 \$1112 \$1162
102.8 7.9 \$1199 \$1253
122.7 9.4 \$1294 \$1353

NOTES:

- Gallery-to-Gallery Panels connect to other Gallery Panels and are available in L-, T-, and Non-symmetrical T-configurations.
- When specifying Gallery-to-Gallery Panels, the installation template (HHALGPT) is required. The recommendation is one template for every 30 panels. Templates are reusable.
- Gallery-to-Gallery Panels must be of equal or lower height than the Standard Gallery Panel attached. The Gallery-to-Gallery Panel cannot be taller than the adjacent panel. If this is needed, please reach out to Tailored Solutions for a custom solution.
- Made of 1½” board with HPL laminate.
- Can be specified with matching or contrasting edge.
- Edgeband is 2mm ABS.
- Available in woodgrain and solid laminates.
- Non-symmetric T-panels vary in size on either side of the adjacent panel.
- Woodgrain laminates can be specified with vertical grain up to 60”W. Horizontal grain is available on all sizes.
- Gallery-to-Gallery Panel widths are available in 18”, 24”, 30”, 36”, 42”, 48”, and 60”W.
- Gallery Panels offer 2½” leveling capability.
- Overall heights line up with adjacent panel.
- Gallery-to-Gallery Panels cap over Standard Gallery Panels and are oversized by 1/8” to maintain true interior dimensions.
- Available with or without the integrated glass option.
- Glass is specified separately.
- Gallery Panels for use with glass have separate model numbers.
- Gallery-to-Gallery Panels are secured with an inset flat bracket under a painted metal cover.
- L-panels are non-handed.

HOW TO SPECIFY

<p>Select Model Number</p> <p>See page 391</p> <p>H R V G 4 2 4 2 G G T</p>	<p>Select Laminate</p> <p>See page 391</p> <p>H</p>	<p>Select Edge</p> <p>See page 391</p> <p>H</p>	<p>Select Grain Direction</p> <p>VLG Horizontal Grain and Solid Laminate only VST Vertical Grain</p> <p>V L G</p>	<p>Select Glide</p> <p>G Glide</p> <p>G</p>
---	---	---	---	--

ABOUND[®] Gallery-to-Gallery Connections

OPEN MARKET



Icon Legend on page 19

WORKSTATIONS

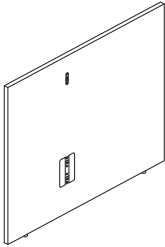

DESCRIPTION	MODEL	SHIP WEIGHT	CUBE	LIST PRICE BY LAMINATE GRADE	
				L1	L2
Non-Symmetrical Connections					
35"H x 18"W/24"W	HRVG351824GGNS	51.1	4.1	\$824	\$860
35"H x 24"W/18"W	HRVG352418GGNS	51.1	4.1	\$824	\$824
35"H x 18"W/30"W	HRVG351830GGNS	58.0	4.7	\$881	\$920
35"H x 30"W/18"W	HRVG353018GGNS	58.0	4.7	\$881	\$920
35"H x 24"W/30"W	HRVG352430GGNS	64.9	5.2	\$912	\$952
35"H x 30"W/24"W	HRVG353024GGNS	64.9	5.2	\$912	\$952
42"H x 18"W/24"W	HRVG421824GGNS	62.1	4.9	\$863	\$901
42"H x 24"W/18"W	HRVG422418GGNS	62.1	4.9	\$863	\$901
42"H x 18"W/30"W	HRVG421830GGNS	70.5	5.6	\$929	\$970
42"H x 30"W/18"W	HRVG423018GGNS	70.5	5.6	\$929	\$970
42"H x 24"W/30"W	HRVG422430GGNS	78.9	6.2	\$962	\$1005
42"H x 30"W/24"W	HRVG423024GGNS	78.9	6.2	\$962	\$1005
50"H x 18"W/24"W	HRVG501824GGNS	73.1	5.7	\$926	\$967
50"H x 24"W/18"W	HRVG502418GGNS	73.1	5.7	\$926	\$967
50"H x 18"W/30"W	HRVG501830GGNS	83.0	6.5	\$997	\$1041
50"H x 30"W/18"W	HRVG503018GGNS	83.0	6.5	\$997	\$1041
50"H x 24"W/30"W	HRVG502430GGNS	92.9	7.2	\$1036	\$1082
50"H x 30"W/24"W	HRVG503024GGNS	92.9	7.2	\$1036	\$1082

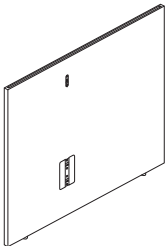

DESCRIPTION	MODEL	SHIP WEIGHT	CUBE	LIST PRICE BY LAMINATE GRADE	
				L1	L2
Non-Symmetrical Connections, Accepts Glass					
35"H x 18"W/24"W	HRVG351824GGNSG	51.1	4.1	\$946	\$988
35"H x 24"W/18"W	HRVG352418GGNSG	51.1	4.1	\$946	\$988
35"H x 18"W/30"W	HRVG351830GGNSG	58.0	4.7	\$1013	\$1058
35"H x 30"W/18"W	HRVG353018GGNSG	58.0	4.7	\$1013	\$1058
35"H x 24"W/30"W	HRVG352430GGNSG	64.9	5.2	\$1050	\$1097
35"H x 30"W/24"W	HRVG353024GGNSG	64.9	5.2	\$1050	\$1097
42"H x 18"W/24"W	HRVG421824GGNSG	62.1	4.9	\$979	\$1022
42"H x 24"W/18"W	HRVG422418GGNSG	62.1	4.9	\$979	\$1022
42"H x 18"W/30"W	HRVG421830GGNSG	70.5	5.6	\$1055	\$1102
42"H x 30"W/18"W	HRVG423018GGNSG	70.5	5.6	\$1055	\$1102
42"H x 24"W/30"W	HRVG422430GGNSG	78.9	6.2	\$1093	\$1142
42"H x 30"W/24"W	HRVG423024GGNSG	78.9	6.2	\$1093	\$1142
50"H x 18"W/24"W	HRVG501824GGNSG	73.1	5.7	\$1032	\$1078
50"H x 24"W/18"W	HRVG502418GGNSG	73.1	5.7	\$1032	\$1078
50"H x 18"W/30"W	HRVG501830GGNSG	83.0	6.5	\$1112	\$1162
50"H x 30"W/18"W	HRVG503018GGNSG	83.0	6.5	\$1112	\$1162
50"H x 24"W/30"W	HRVG502430GGNSG	92.9	7.2	\$1156	\$1208
50"H x 30"W/24"W	HRVG503024GGNSG	92.9	7.2	\$1156	\$1208

NOTES:

- Gallery-to-Gallery Panels connect to other Gallery Panels and are available in L-, T-, and Non-symmetrical T-configurations.
- When specifying Gallery-to-Gallery Panels, the installation template (HHALGPT) is required. The recommendation is one template for every 30 panels. Templates are reusable.
- Gallery-to-Gallery Panels must be of equal or lower height than the Standard Gallery Panel attached. The Gallery-to-Gallery Panel cannot be taller than the adjacent panel. If this is needed, please reach out to Tailored Solutions for a custom solution.
- Made of 1 1/8" board with HPL laminate.
- Can be specified with matching or contrasting edge.
- Edgeband is 2mm ABS.
- Available in woodgrain and solid laminates.
- Non-symmetric T-panels vary in size on either side of the adjacent panel.
- Woodgrain laminates can be specified with vertical grain up to 60"W. Horizontal grain is available on all sizes.
- Gallery-to-Gallery Panel widths are available in 18", 24", 30", 36", 50", 48", and 60"W.
- Gallery Panels offer 2 1/2" leveling capability.
- Overall heights line up with adjacent panel.
- Gallery-to-Gallery Panels cap over Standard Gallery Panels and are oversized by 1/8" to maintain true interior dimensions.
- Available with or without the integrated glass option.
- Glass is specified separately.
- Gallery Panels for use with glass have separate model numbers.
- Gallery-to-Gallery Panels are secured with an inset flat bracket under a painted metal cover.
- L-panels are non-handed.

HOW TO SPECIFY

<p>Select Model Number</p> <p>HRVG421830GGNS</p>	<p>Select Laminate</p> <p>See page 391</p> <p>H</p>	<p>Select Edge</p> <p>See page 391</p> <p>H</p>	<p>Select Grain Direction</p> <p>VLG Horizontal Grain and Solid Laminate only VST Vertical Grain</p> <p>VLG</p>	<p>Select Glide</p> <p>G Glide</p> <p>G</p>
---	--	--	--	--

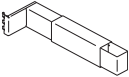
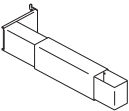
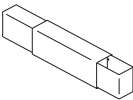

Height Adjustable Tie-In Brackets

	DESCRIPTION	MODEL	SHIP WEIGHT	CUBE	LIST PRICE BY PAINT GRADE		
					P1	P2	P3
	Rectangle Leg, T-Foot Brackets HAT to Panel, Left Hand	HHALRETL	4.0	0.2	\$150	\$165	\$173
	HAT to Panel, Right Hand	HHALRETR	4.0	0.2	\$150	\$165	\$173
	HAT to Gallery Panel	HHALRETG	3.5	0.2	\$150	\$165	\$173
	Rectangle Leg, C-Foot Brackets HAT to Panel, Left Hand	HHALRECL	4.0	0.2	\$150	\$165	\$173
	HAT to Panel, Right Hand	HHALRECR	4.0	0.2	\$150	\$165	\$173
	HAT to Gallery Panel	HHALRECG	3.5	0.2	\$150	\$165	\$173

! Not compatible with Coordinate™ model HHABETA2S2L.

NOTES:

- Tie-in brackets are used to tie a height adjustable table to either a Standard Panel or Gallery Panel for added support.
- Bracket ties into the approach side of the height adjustable worksurface — this removes the need for a wing panel.
- Can be used as a value engineering option to replace wing panels.
- Available in all paint colors to match panel trim or coordinating colors to the height adjustable base.

! Brackets must be used on a return panel, not a spine wall, except if stations are back-to-back on a spine wall and a tie-in bracket is used at a minimum every 96”.

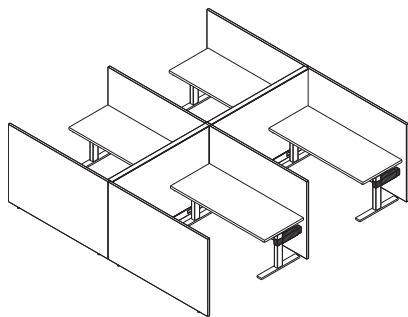

SINGLE BRACKET

Systems Application

- Max Height (with Glass): 65”H
- Max Width: 96”; tops greater than 72”W **will not align.**

Gallery Panel Application

- Max Height (with Glass): 65”H
- Max Width: 75”; no top size restrictions.

DUAL-SIDED PANEL BENCH

Systems Application

- Max Height (with Glass): 65”H
- Bracket needed every 96” on both sides; tops greater than 72”W **will not align.**

Gallery Panel Application

- Max Height (with Glass): 65”H
- Bracket Needed: Single Panel (75”) with brackets on each leg (same height).

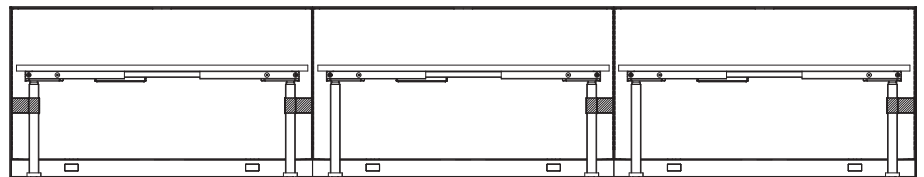

HOW TO SPECIFY

<p>Select Model Number</p> <p>HHALRECL.</p>	<p>Select Paint Color</p> <p>See page 391</p> <p>DW</p>
--	--



ACCELERATE® Strengthened Connection Posts

	DESCRIPTION	MODEL	SHIP WEIGHT	CUBE	LIST PRICE BY PAINT GRADE		
					P1	P2	P3
	120° 2-Way Connector Posts						
	For 35"H Panels	HEC35P2N	6 ⑤	0.5	\$86	\$95	\$112
	For 42½"H Panels	HEC42P2N	6 ⑤	0.5	\$103	\$112	\$129
	For 50"H Panels	HEC50P2N	7 ⑤	0.6	\$121	\$130	\$147
	For 57½"H Panels	HEC57P2N	8 ⑤	0.8	\$129	\$138	\$155
	For 65"H Panels	HEC65P2N	8 ⑤	0.8	\$135	\$144	\$161
	For 72½"H Panels	HEC72P2N	9 ⑤	0.9	\$143	\$152	\$169
For 80"H Panels	HEC80P2N	9 ⑤	0.9	\$150	\$159	\$176	
	120° 3-Way Connector Posts						
	For 35"H Panels	HEC35P3N	6 ⑤	0.5	\$81	\$90	\$107
	For 42½"H Panels	HEC42P3N	6 ⑤	0.5	\$98	\$107	\$124
	For 50"H Panels	HEC50P3N	7 ⑤	0.6	\$116	\$125	\$142
	For 57½"H Panels	HEC57P3N	8 ⑤	0.8	\$124	\$133	\$150
	For 65"H Panels	HEC65P3N	8 ⑤	0.8	\$130	\$139	\$156
	For 72½"H Panels	HEC72P3N	9 ⑤	0.9	\$138	\$147	\$164
For 80"H Panels	HEC80P3N	9 ⑤	0.9	\$145	\$154	\$171	
	Extended Straight Connector Posts						
	For 35"H Panels	HEC35PSN	6 ⑤	0.5	\$86	\$95	\$112
	For 42½"H Panels	HEC42PSN	6 ⑤	0.5	\$103	\$112	\$129
	For 50"H Panels	HEC50PSN	7 ⑤	0.6	\$121	\$130	\$147
	For 57½"H Panels	HEC57PSN	8 ⑤	0.8	\$129	\$138	\$155
	For 65"H Panels	HEC65PSN	8 ⑤	0.8	\$135	\$144	\$161
	For 72½"H Panels	HEC72PSN	9 ⑤	0.9	\$145	\$154	\$171
For 80"H Panels	HEC80PSN	9 ⑤	0.9	\$150	\$159	\$176	
	"L" Connector Posts						
	For 35"H Panels	HEC35PLN	6 ⑤	0.5	\$91	\$100	\$117
	For 42½"H Panels	HEC42PLN	6 ⑤	0.5	\$108	\$117	\$134
	For 50"H Panels	HEC50PLN	7 ⑤	0.6	\$126	\$135	\$152
	For 57½"H Panels	HEC57PLN	8 ⑤	0.8	\$134	\$143	\$160
	For 65"H Panels	HEC65PLN	8 ⑤	0.8	\$140	\$149	\$166
	For 72½"H Panels	HEC72PLN	9 ⑤	0.9	\$148	\$157	\$174
For 80"H Panels	HEC80PLN	9 ⑤	0.9	\$155	\$164	\$181	
	"T" Connector Posts						
	For 35"H Panels	HEC35PTN	6 ⑤	0.5	\$86	\$95	\$112
	For 42½"H Panels	HEC42PTN	6 ⑤	0.5	\$103	\$112	\$129
	For 50"H Panels	HEC50PTN	7 ⑤	0.6	\$121	\$130	\$147
	For 57½"H Panels	HEC57PTN	8 ⑤	0.8	\$129	\$138	\$155
	For 65"H Panels	HEC65PTN	8 ⑤	0.8	\$135	\$144	\$161
	For 72½"H Panels	HEC72PTN	9 ⑤	0.9	\$143	\$152	\$169
For 80"H Panels	HEC80PTN	9 ⑤	0.9	\$150	\$159	\$176	
	"X" Connector Posts						
	For 35"H Panels	HEC35PXN	6 ⑤	0.5	\$81	\$90	\$107
	For 42½"H Panels	HEC42PXN	6 ⑤	0.5	\$98	\$107	\$124
	For 50"H Panels	HEC50PXN	7 ⑤	0.6	\$116	\$125	\$142
	For 57½"H Panels	HEC57PXN	8 ⑤	0.8	\$124	\$133	\$150
	For 65"H Panels	HEC65PXN	8 ⑤	0.8	\$130	\$139	\$156
	For 72½"H Panels	HEC72PXN	9 ⑤	0.9	\$138	\$147	\$164
For 80"H Panels	HEC80PXN	9 ⑤	0.9	\$145	\$154	\$171	

NOTES:

- Specify connectors based on number and placement of panels.
- Connector posts are specified separately from connector straps — specify post to tallest panel and straps based on connection (see variable height example on straps page).
- Specify connector to fit height of tallest panel.
- Connectors are made of extruded aluminum.
- Straight Connector model HSCKTPS ships standard in bulk pack.
- Connector posts where power pole will enter need to be specified with single connector straps, model HECS1.

ⓘ In-line connector must be specified for all in-line connections.

ⓘ If adding to existing panels produced prior to 04/13/2016, please contact Customer Support for compatibility.

HOW TO SPECIFY

<p>Select Model Number</p>	<p>Select Paint Color</p> <p>See page 441 of the HON 2020 Full Line Pricer</p>
<p>H E C 3 5 P 2 N .</p>	<p>T 3</p>

	DESCRIPTION	MODEL	SHIP WEIGHT	CUBE	LIST PRICE
	120° 2-Way Connector Strap	HECSV	1.4	0.2	\$20
	120° 3-Way Connector Strap	HECSY	2.2	0.2	\$25
	Extended Straight Connector Strap	HECSS	1.6	0.2	\$20
	“L” Connector Strap	HECSL	1.5	0.2	\$15
	“T” Connector Strap	HECST	2.3	0.2	\$20
	“X” Connector Strap	HECSX	3.0	0.2	\$25
	Single Connector Strap	HECSI	1.9	0.2	\$15
	In-line Connector NOTES: No need to specify finish. SPECIFYING EXAMPLE: HSCKTPS.X	HSCKTPS	0.5	0.1	\$19

NOTES:

- Strengthened Connection Straps provide more rigidity to panel connections, especially when not tied into a station with a worksurface or storage, i.e., when Coordinate™ Height Adjustable bases are used or when using panels strictly to divide space without tying in other components.
- Connector strap type should be specified based on the tallest panel connection type. Connector straps and posts are specified separately.
- Lower height panels will connect with variable height trim.
- See examples below.
- Connector straps can be retrofitted on any existing Accelerate® stations that were produced from April 2016 to present.
- Will fit on existing connector posts — only straps would need to be specified.
- Single Straps (HECSI) are used when power poles enter at the connector post and in variable height applications where the tallest panel is a single and one or more panels is lower.

Connector Post



New Connector Straps

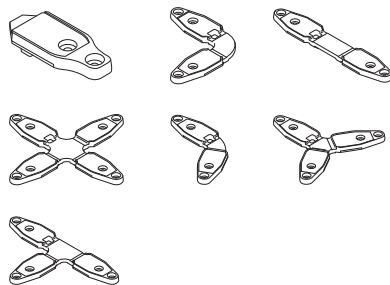

+

“T” 2 High, “L” 1 Low

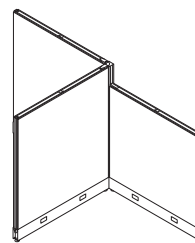

- 1 — “T” Connector Post
- 1 — VH Post Trim
- 3 — Top Caps
- 3 — End Caps
- 1 — “L” Connector Strap

“T” 1 High, “L” 2 Low

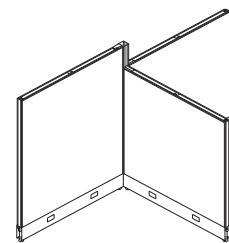

- 1 — “T” Connector Post
- 2 — VH Post Trim
- 3 — Top Caps
- 3 — End Caps
- 1 — Single Connector Strap

HOW TO SPECIFY

Select Model Number



BIRK® TABLES



TABLES

BIRK® TABLES

Why complicate matters when you can keep it simple? Offering a modern, minimalist design, Birk tables have a look that's as streamlined as its specification process. Whether you're looking for something well-rounded or think it's hip to be square, Birk is there for you with a variety of top shapes, sizes, and table heights. It's the support system you need to help people come together, collaborate, and socialize — anywhere.



FEATURES

- Ideal for informal meeting spaces and hospitality areas.
- Modern, minimalist design makes it easy to match a variety of styles.
- Designed for use with HON chairs, stools, and soft seating.
- Five different base heights outfit a variety of spaces.
- Five unique top shapes and sizes coordinate seamlessly with any surrounding aesthetic.
- The personal table is light in scale and gives people the ability to take notes and work in a lounge setting.

BIRK® ORDERING INFORMATION

LAMINATE

L1 LAMINATES CODES

Woodgrain

- ◆ Bourbon Cherry **H**
- ◆ Cognac **COGN**
- ◆ Florence Walnut **LFW1**
- ◆ Harvest **C**
- ◆ Kingswood Walnut **LK11**
- ◆ Mahogany **N**
- ◆ Mocha **MOCH**
- ◆ Natural Maple **D**
- ◆ Pinnacle **PINC**
- ◆ Shaker Cherry **F**
- ◆ Sterling Ash **LSA1**

Solid

- ◆ Black **P**
- ◆ Charcoal **S**
- ◆ Designer White **LDW1**
- ◆ Loft **LOFT**

Patterned

- ◆ Sheer Mesh **A5**
- ◆ Silver Mesh **B9**
- ◆ Steel Mesh **A9**

L2 LAMINATES CODES

Woodgrain

- ◆ Lowell Ash **LLA1**
- ◆ Natural Recon **LNR1**
- ◆ Phantom Ecru **LPE1**
- ◆ Portico Teak **LPT1**
- ◆ Skyline Walnut **LSW1**

EDGE BAND

EDGE BAND CODES

- ◆ Black **P**
- ◆ Bourbon Cherry **H**
- ◆ Charcoal **S**
- ◆ Cognac **COGN**
- ◆ Designer White **DW**
- ◆ Florence Walnut **FW**
- ◆ Greige **R**
- ◆ Harvest **C**
- ◆ Kingswood Walnut **KI**
- ◆ Loft **LOFT**
- ◆ Lowell Ash **DL**
- ◆ Mahogany **N**
- ◆ Mocha **MOCH**
- ◆ Muslin **T**
- ◆ Natural Maple **D**
- ◆ Natural Recon **NR**
- ◆ Phantom Ecru **PE**
- ◆ Pinnacle **PINC**
- ◆ Platinum **K**
- ◆ Portico Teak **DP**
- ◆ Shaker Cherry **F**
- ◆ Skyline Walnut **SW**
- ◆ Sterling Ash **SA**

PAINT

PAINT CODES

P1

- ◆ Black Mica Texture **P6P**
- ◆ Textured Brownstone **P7J**
- ◆ Textured Charcoal **P7A**
- ◆ Textured Designer White ... **PK7**
- ◆ Textured Loft **P7L**
- ◆ Textured Muslin **P7M**
- ◆ Textured Titanium **P8V**

P2

- ◆ Solar Black **P8X**
- ◆ Textured Silver **PR8**

Recommended Edgeband Color Selection:

Laminate		Edgeband	
Bourbon Cherry	H	Bourbon Cherry	H
Cognac	COGN	Cognac	COGN
Florence Walnut	LFW1	Florence Walnut	FW
Harvest	C	Harvest	C
Kingswood Walnut	LK11	Kingswood Walnut	KI
Mahogany	N	Mahogany	N
Mocha	MOCH	Mocha	MOCH
Natural Maple	D	Natural Maple	D
Pinnacle	PINC	Pinnacle	PINC
Shaker Cherry	F	Shaker Cherry	F
Sterling Ash	LSA1	Sterling Ash	SA
Black	P	Black	P
Charcoal	S	Charcoal	S
Designer White	LDW1	Designer White	DW
Sheer Mesh	A5	Muslin	T
Silver Mesh	B9	Loft	LOFT
Steel Mesh	A9	Charcoal	S
Lowell Ash	LLA1	Lowell Ash	DL
Natural Recon	LNR1	Natural Recon	NR
Phantom Ecru	LPE1	Phantom Ecru	PE
Portico Teak	LPT1	Portico Teak	DP
Skyline Walnut	LSW1	Skyline Walnut	SW
Loft	LOFT	Loft	LOFT



	DESCRIPTION	MODEL	SHIP WEIGHT	CUBE	LIST PRICE BY LAMINATE GRADE	
					L1	L2
	Round Tops with Knife Edge					
	30"W Round Top	HCWTRND30J	28	2.8	\$441	\$464
	36"W Round Top	HCWTRND36J	38	3.8	\$481	\$506
	42"W Round Top	HCWTRND42J	50	5.1	\$568	\$597
	Round Tops with Flat Edge					
	30"W Round Top	HCWTRND30G	28	2.8	\$339	\$356
	36"W Round Top	HCWTRND36G	38	3.8	\$370	\$389
	42"W Round Top	HCWTRND42G	50	5.1	\$437	\$459
	Square Tops with Knife Edge					
	30"W Square Top	HCWTSQR30J	34	2.6	\$391	\$411
	36"W Square Top	HCWTSQR36J	47	3.8	\$458	\$481
	42"W Square Top	HCWTSQR42J	62	5.0	\$542	\$570
	Square Tops with Flat Edge					
	30"W Square Top	HCWTSQR30G	34	2.6	\$301	\$317
	36"W Square Top	HCWTSQR36G	47	3.8	\$352	\$370
	42"W Square Top	HCWTSQR42G	62	5.0	\$417	\$438
	Soft Square Tops with Knife Edge					
	30"W Soft Square Top	HCWTSFTS30J	34	2.6	\$441	\$464
	36"W Soft Square Top	HCWTSFTS36J	47	3.8	\$481	\$506
	42"W Soft Square Top	HCWTSFTS42J	62	5.0	\$568	\$597
	Soft Square Tops with Flat Edge					
	30"W Soft Square Top	HCWTSFTS30G	34	2.6	\$339	\$356
	36"W Soft Square Top	HCWTSFTS36G	47	3.8	\$370	\$389
	42"W Soft Square Top	HCWTSFTS42G	62	5.0	\$437	\$459
	Booth Tops with Knife Edge					
	56"W x 36"D Booth Top	HCWTB3656J	90	5.6	\$611	\$642
	84"W x 36"D Booth Top	HCWTB3684J	150	8.2	\$923	\$970
	Booth Tops with Flat Edge					
	56"W x 36"D Booth Top	HCWTB3656G	90	5.6	\$470	\$494
	84"W x 36"D Booth Top	HCWTB3684G	150	8.2	\$710	\$746
	Soft Rectangle Tops with Knife Edge					
	56"W x 36"D Soft Rectangle Top	HCWTSR3656J	90	5.6	\$637	\$669
	84"W x 36"D Soft Rectangle Top	HCWTSR3684J	150	8.2	\$949	\$997
	Soft Rectangle Tops with Flat Edge					
	56"W x 36"D Soft Rectangle Top	HCWTSR3656G	90	5.6	\$490	\$515
	84"W x 36"D Soft Rectangle Top	HCWTSR3684G	150	8.2	\$730	\$767

TABLES

NOTES:

- Tops configured with pilot holes for easy installation of base.

HOW TO SPECIFY

<p>Select Model Number</p> <p>HCWTSQR36J</p>	<p>Select Grommet Option</p> <p>N No Grommet</p> <p>N</p>	<p>Select Laminate</p> <p>See page 2</p> <p>LSA1</p>	<p>Select Edge Color</p> <p>See page 2</p> <p>SA</p>
--	---	--	--

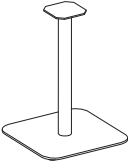
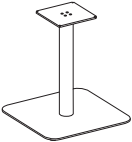
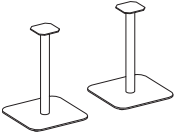

	DESCRIPTION	MODEL	SHIP WEIGHT	CUBE	LIST PRICE BY PAINT GRADE	
					P1	P2
	Single Pedestal, Medium					
	18"H Single Pedestal Base	HCWTSBM18	60	3.3	\$545	\$600
	27"H Single Pedestal Base	HCWTSBM27	60	3.3	\$549	\$605
	29"H Single Pedestal Base	HCWTSBM29	60	3.3	\$554	\$610
	36"H Single Pedestal Base	HCWTSBM36	62	3.3	\$559	\$616
	42"H Single Pedestal Base	HCWTSBM42	66	3.6	\$567	\$625
	Single Pedestal, Large					
	18"H Single Pedestal Base	HCWTSBL18	95	3.8	\$717	\$789
	27"H Single Pedestal Base	HCWTSBL27	95	3.8	\$741	\$816
	29"H Single Pedestal Base	HCWTSBL29	95	3.8	\$775	\$853
	36"H Single Pedestal Base	HCWTSBL36	98	3.8	\$787	\$866
	42"H Single Pedestal Base	HCWTSBL42	101	4.2	\$802	\$883
	Double Pedestal, Medium					
	27"H Double Pedestal Base	HCWTDSBM27	120	6.5	\$1098	\$1210
	29"H Double Pedestal Base	HCWTDSBM29	120	6.5	\$1108	\$1220
	36"H Double Pedestal Base	HCWTDSBM36	124	6.5	\$1118	\$1232
	42"H Double Pedestal Base	HCWTDSBM42	132	7.2	\$1134	\$1250

TABLES

NOTES:

- See application matrix for top and base compatibility.
- Bases feature 1/4"H non-leveling slide glides.
- Some assembly required.

	Round, Square, Soft Square			Booth, Soft Rectangle	
	30"W	36"W	42"W	56"W	84"W
Single Pedestal, Medium	•	•			
Single Pedestal, Large			•		
Double Pedestal, Medium				•	•

HOW TO SPECIFY

Select Model Number	Select Paint Color
	See page 2
HCWTSBL36	PR8



BIRK® Personal Table



DESCRIPTION

Personal Table
17"W x 15"D x 28"H

MODEL	SHIP WEIGHT	CUBE	LIST PRICE BY LAMINATE GRADE	
			L1	L2
HCWPT	18	2.7	\$313	\$323

NOTES:

- Top features flat edge on all sides.
- Top configured with pilot holes for easy installation of base.
- Some assembly required.

TABLES

HOW TO SPECIFY

<p>Select Model Number</p> <p>See page 2</p> <p>HCWPT .</p>	<p>Select Laminate</p> <p>See page 2</p> <p>LSA1 .</p>	<p>Select Edge Color</p> <p>See page 2</p> <p>SA .</p>	<p>Select Paint Color</p> <p>See page 2</p> <p>P2 upcharge + \$12</p> <p>PR8</p>
--	---	---	---

COORDINATE™



Coordinate™ Height Adjustable Base shown with Ignition® 2.0 Seating and 10500 Series™ Desking.

TABLES

COORDINATE™

Sit-to-stand working is easy when you have a table with the power to move with you. The human body wasn't meant to sit for hours on end; and as your body's needs change throughout the day, these height adjustable tables change with you.

Warranty is 7 years.



FEATURES

- The standard memory preset, basic up and down, hands-free foot pedal, rotator, or paddle control options allow for quick and easy adjustments throughout your day.
- Telescoping table base can accommodate work surfaces from 42"-72" wide on the 2-leg model, and from 24"-30" deep.
- Available in 2- or 3-leg, rectangle C- and T-shaped foot options to accommodate your layout preferences.
- Nickel, Black, White finishes match any neutral HON paint or finish color.
- All bases are compatible with electrical accessories and select worksurfaces. See the HON 2020 Full Line Pricer for more information.

LEG OPTIONS



Rectangle Leg, T Foot



Rectangle Leg, C Foot

CONTROL OPTIONS



UD Basic Up/Down



MEM Memory Preset



PDL Paddle



RTG Rotating



FPD Foot Pedal

COORDINATE™ ORDERING INFORMATION

TABLES

LAMINATE

L1 LAMINATES CODES

Woodgrain

◆ Bourbon Cherry	H
◆ Cognac	COGN
◆ Florence Walnut	LFW1
◆ Harvest	C
◆ Kingswood Walnut	LK11
◆ Loft	LOFT
◆ Mahogany	N
◆ Mocha	MOCH
◆ Natural Maple	D
◆ Pinnacle	PINC
◆ Shaker Cherry	F
◆ Sterling Ash	LSA1

Solid

◆ Black	P
◆ Charcoal	S
◆ Designer White	LDW1
◆ Loft	LOFT

Patterned

◆ Sheer Mesh	A5
◆ Silver Mesh	B9
◆ Steel Mesh	A9
◆ Canyon Zephyr	K9
◆ Desert Zephyr	K8
◆ Shadow Zephyr	K1
◆ Gray	G2
◆ Grey Tigris	L6
◆ White	G1
◆ Whitestone	K4

L2 LAMINATES CODES

Woodgrain

◆ Lowell Ash	LLA1
◆ Natural Recon	LNRI
◆ Phantom Ecrú	LPE1
◆ Portico Teak	LPT1
◆ Skyline Walnut	LSW1

EDGE

EDGE CODES

Woodgrain

◆ Bourbon Cherry	H
◆ Cognac	COGN
◆ Florence Walnut	FW
◆ Harvest	C
◆ Kingswood Walnut	KI
◆ Light Gray	Q
◆ Lowell Ash	DL
◆ Mahogany	N
◆ Mocha	MOCH
◆ Natural Maple	D
◆ Natural Recon	NR
◆ Phantom Ecrú	PE
◆ Pinnacle	PINC
◆ Portico Teak	DP
◆ Shaker Cherry	F
◆ Skyline Walnut	SW
◆ Sterling Ash	SA

Solid

◆ Black	P
◆ Charcoal	S
◆ Designer White	DW
◆ Greige	R
◆ Loft	LOFT
◆ Muslin	T
◆ Platinum	K

PAINT

PAINT CODES

P1

◆ Black	P
◆ Brownstone	P7D
◆ Charcoal	S
◆ Designer White	PJW
◆ Fossil	P28
◆ Greige	T5
◆ Light Gray	Q
◆ Loft	LOFT
◆ Muslin	T3
◆ Putty	L
◆ Shadow *	SHDW
◆ Titanium	P8T

P2

◆ Champagne Metallic	T4
◆ Platinum Metallic	T1
◆ Silver	PR6
◆ Solar Black	P8X

P3

◆ Atom	P8S
◆ Bullseye	PJF
◆ Ember	P8P
◆ Ion	P8N
◆ Iris	P8J
◆ Krypton	P8F
◆ Regatta	P8M

◆◆◆ For lead time information see page 19 of the HON 2020 Full Line Pricer.

* De-emphasized



COORDINATE™ Height Adjustable Bases — Two-Leg

TABLES

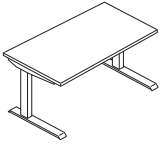
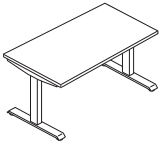

DESCRIPTION

MODEL

SHIP WEIGHT

CUBE

LIST PRICE

Coordinate™ Height Adjustable Base – 2 Stage

2-Leg Rectangle T Foot
2-Leg Rectangle C Foot

HREC2S2LTF
HREC2S2LCF

66
66

2.4
2.4

\$940
\$940

NOTES:

- Base is a dual motor 2-stage design. Legs raise from 25⁵/₈" to 45¹/₄".
- Base telescopes to accommodate any rectangular worksurface between 24"D x 42"W and 30"D x 72"W.
- Supports weight capacity of 250 lbs. (excluding worksurface weight). Foundation™, Systems, Voi®, 10500, and Preside® all have worksurfaces within this range.
- **HON 7-Year Limited Warranty.**

Coordinate™ Height Adjustable Base – Max 3 Stage

2-Leg Rectangle T Foot

HMREC3S2LTF

66

2.4

\$1161

NOTES:

- Base is a dual motor 2-stage design. Legs raise from 21⁵/₈" to 47³/₄".
- Base telescopes to accommodate any rectangular worksurface between 24"D x 42"W and 30"D x 96"W.
- Supports weight capacity of 350 lbs. (excluding worksurface weight). Foundation™, Systems, Voi®, 10500, and Preside® all have worksurfaces within this range.
- **HON 7-Year Limited Warranty.**

Coordinate™ Height Adjustable Base – 3 Stage

2-Leg Rectangle T Foot
2-Leg Rectangle C Foot

HREC3S2LTF
HREC3S2LCF

66
66

2.4
2.4

\$1036
\$1036

NOTES:

- Base is a dual motor 3-stage design. Legs raise from 21⁵/₈" to 47³/₄".
- Base telescopes to accommodate any rectangular worksurface between 24"D x 42"W and 30"D x 72"W.
- Supports weight capacity of 250 lbs. (excluding worksurface weight). Foundation™, Systems, Voi®, 10500, and Preside® all have worksurfaces within this range.
- **HON 7-Year Limited Warranty.**

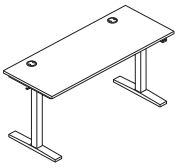

Coordinate™ Easy to Assemble 2-Leg Height Adjustable Base – 2 Stage

24"D Feet

HHABETA2S2L

77 [Ⓢ]

4.0

\$725

NOTES:

- Base telescopes to accommodate rectangular worksurfaces between 24"D x 48"W and 30"D x 60"W.
- Supports weight capacity of 180 lbs.
- **HON 5-Year Limited Warranty.**

ⓘ Available in SVR Silver finish only.

ⓘ Available with Basic Up/Down control only.

NOTES:

- Compatible with select rectangular Voi® and Systems Worksurfaces. See page 718 of the HON 2020 Full Line Pricer for more information.

HOW TO SPECIFY

<p>Select Model Number</p> <p>H R E C 2 S 2 L T F .</p>	<p>Select Paint Color</p> <p>P71 Black P8L Nickel PD8 White SVR Silver</p> <p><i>Available on model HHABETA2S2L only</i></p> <p>P 7 1 .</p>	<p>Select Foot</p> <p>X Standard Foot</p> <p>X .</p>	<p>Select Keypad</p> <p>UD Basic Up/Down MEM Memory Preset PDL Paddle RTG Rotating (\$50 upcharge) FPD Foot Pedal (\$175 upcharge)</p> <p>M E M</p>
--	--	---	--

COORDINATE™ Height Adjustable Bases — Three-Leg

OPEN MARKET

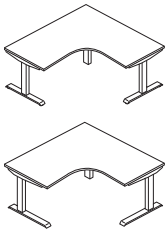

DESCRIPTION

Coordinate™ Height Adjustable Base – 3 Stage
3-Leg Rectangle T Foot
3-Leg Rectangle C Foot

MODEL

HREC3S3LTF
HREC3S3LCF

SHIP WEIGHT

91
91

CUBE

3.6
3.6

LIST PRICE

\$1711
\$1711

NOTES:

- Base is a three motor 3-stage design. Legs raise from 21⁵/₈" to 47³/₄".
- Base telescopes to accommodate worksurfaces between 24"D x 42"W¹ x 60"W² and 30"D x 72"W¹ x 72"W².
- Supports weight capacity of 375 lbs. (excluding worksurface weight). Can be used with 48" 120 degree and worksurface models.
- **HON 7-Year Limited Warranty.**

NOTES:

- Compatible with select Corner Cove Worksurfaces. See page 719 of the HON 2020 Full Line Pricer for more information.
- All bases are compatible with electrical accessories on page 716 of the HON 2020 Full Line Pricer.
- ! When using two worksurfaces, a flat bracket is required. Bracket purchased separately — HHN831124, HHN831130 — see page 589 of the HON 2020 Full Line Pricer.
- ! Telescoping horizontal frame will extend just over 2" from underside of the worksurface.

TABLES

HOW TO SPECIFY

<p>Select Model Number</p> <p>H R E C 3 S 3 L T F .</p>	<p>Select Paint Color</p> <p>P71 Black P8L Nickel PD8 White</p> <p>P 7 1 .</p>	<p>Select Foot</p> <p>X Standard Foot</p> <p>X .</p>	<p>Select Keypad</p> <p>UD Basic Up/Down MEM Memory Preset PDL Paddle RTG Rotating (\$50 upcharge) FPD Foot Pedal (\$175 upcharge)</p> <p>M E M</p>
--	---	---	--



Height Adjustable Bases — Simple Specification

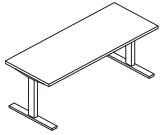

Base shown with work surface attached.

DESCRIPTION

Coordinate™ Height Adjustable Base – 2 Stage
24”D Feet and Worksurface Brackets

MODEL SHIP WEIGHT CUBE LIST PRICE

HHAB2S2L 63 2.4 \$940

NOTES:

- Base is a dual motor 2-stage design. Legs raise from 25⁵/₈” to 45¹/₄”.
- Base telescopes to accommodate any rectangular work surface between 24”D x 42”W and 30”D x 72”W.
- Supports weight capacity of 250 lbs. (excluding work surface weight). See page 718 of the HON 2020 Full Line Pricer for Voi® Worksurfaces. See page 718 of the HON 2020 Full Line Pricer for Systems Worksurfaces. For Height Adjustable Base Accessories see page 716 of the HON 2020 Full Line Pricer. Foundation™, Systems, Voi®, 10500, and Preside® all have work surfaces within this range.
- Comes standard with one-touch, four memory controller with digital display; no specification needed, available in black finish only.
- **HON 7-Year Limited Warranty.**

ⓘ When attaching a Keyboard Tray, remember to also specify a Keyboard Spacer Kit (HKBS).

ⓘ Telescoping horizontal frame will extend just over 2” from underside of the work surface.

SPECIFYING EXAMPLE: HHAB2S2L.P8L

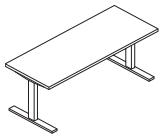

Base shown with work surface attached.

Coordinate™ Height Adjustable Base – 3 Stage
24”D Feet and Worksurface Brackets

HHAB3S2L 67 2.4 \$1036

NOTES:

- Base is a dual motor 3-stage design. Legs raise from 21⁵/₈” to 47³/₄”.
- Base telescopes to accommodate any rectangular work surface between 24”D x 42”W and 30”D x 72”W.
- Supports weight capacity of 250 lbs. (excluding work surface weight). Foundation™, Systems, Voi®, 10500, and Preside® all have work surfaces within this range.
- Comes standard with one-touch, four memory controller with digital display; no specification needed, available in black finish only.
- **HON 7-Year Limited Warranty.**

ⓘ Telescoping horizontal frame will extend just over 2” from underside of the work surface.

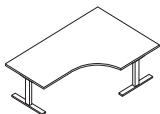

Base shown with work surface attached.

Coordinate™ 3-Leg Height Adjustable Base – 3 Stage
24”D Feet and Worksurface Brackets

HHAB3S3L 91 3.6 \$1711

NOTES:

- Base is a three motor 3-stage design. Legs raise from 21⁵/₈” to 47³/₄”.
- Base telescopes to accommodate work surfaces between 24”D x 42”W¹ x 60”W² and 30”D x 72”W¹ x 72”W².
- Supports weight capacity of 330 lbs. (excluding work surface weight). Can be used with 48” 120 degree and work surface models.
- Comes standard with one-touch, four memory controller with digital display; no specification needed, available in black finish only.
- **HON 7-Year Limited Warranty.**

ⓘ When using two work surfaces, a flat bracket is required. Bracket purchased separately — HHN831124, HHN831130 — see page 589 of the HON 2020 Full Line Pricer.

ⓘ Telescoping horizontal frame will extend just over 2” from underside of the work surface.

NOTES:

- Compatible with select Rectangle and Corner Cove Worksurfaces. See pages 718 and 719 of the HON 2020 Full Line Pricer for more information.

ⓘ Coordinate™ Height Adjustable Bases not compatible with 36”D rectangular work surfaces.

TABLES

HOW TO SPECIFY

<p>Select Model Number</p> <p>HHAB2S2L .</p>	<p>Select Finish</p> <p>P71 Black P8L Nickel P8D White</p> <p>P8L</p>
---	--

COORDINATE™ Screens

OPEN MARKET

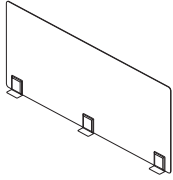

DESCRIPTION	MODEL	SHIP WEIGHT	CUBE	LIST PRICE BY PAINT GRADE		
				P1	P2	P3
Above Screens						
20"H x 45½"W, for 48"W Surfaces	HMTLSCRN2048	36.4	5.5	\$636	\$656	\$676
20"H x 51½"W, for 54"W Surfaces	HMTLSCRN2054	39.7	6.1	\$668	\$688	\$708
20"H x 57½"W, for 60"W Surfaces	HMTLSCRN2060	43.1	6.7	\$702	\$722	\$742
20"H x 63½"W, for 66"W Surfaces	HMTLSCRN2066	46.4	7.3	\$737	\$757	\$777
25"H x 45½"W, for 48"W Surfaces	HMTLSCRN2548	42.8	6.7	\$700	\$720	\$740
25"H x 51½"W, for 54"W Surfaces	HMTLSCRN2554	46.9	7.4	\$735	\$755	\$775
25"H x 57½"W, for 60"W Surfaces	HMTLSCRN2560	51.1	8.2	\$772	\$792	\$812
25"H x 63½"W, for 66"W Surfaces	HMTLSCRN2566	55.3	9.0	\$810	\$830	\$850

NOTES:

- Above screens are single-piece steel construction.
- Screens mount by using double stick tape, which provides the ability to mount to any surface.

TABLES

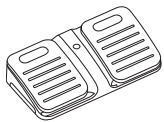

DESCRIPTION	MODEL	SHIP WEIGHT	CUBE	LIST PRICE
Foot Control Pedal	HFTPDL	5	0.1	\$175

NOTES:

- Provides hands-free method for height adjustment.
- No specification needed.
- Pedal can be ordered with table or to retrofit on a current table.

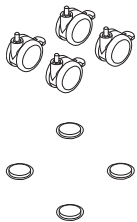

DESCRIPTION	MODEL	SHIP WEIGHT	CUBE	LIST PRICE
Caster 4-Pack	HHABCSTRPK	1 ☉	0.1	\$75
☹ Field installable. Not available on model HHABETA2S2L. No specification needed.				
Slide Glide 4-Pack	HHABGLIDE	1 ☉	0.1	\$60
☹ Field installable. When placed under base, allows table to be pushed/pulled to move. No specification needed.				

HOW TO SPECIFY

Select Model Number HMTLSCRN2054	Select Frame Paint P8T	Select Bracket Paint P8T
--	----------------------------------	------------------------------------



	DESCRIPTION	MODEL	SHIP WEIGHT	CUBE	LIST PRICE BY LAMINATE GRADE	
					L1	L2
	Rectangle Worksurfaces with External Stiffener					
	84"W x 24"D	HHAW2484PS	97	5.4	\$851	\$871
	96"W x 24"D	HHAW2496PS	100	5.7	\$890	\$910
	84"W x 30"D	HHAW3084PS	113	6.6	\$901	\$921
	96"W x 30"D	HHAW3096PS	116	7.0	\$940	\$960
	Rectangle Worksurfaces with External Stiffener, No Grommet					
	84"W x 24"D	HHAW2484PNS	97	5.4	\$851	\$871
	96"W x 24"D	HHAW2496PNS	100	5.7	\$890	\$910
	84"W x 30"D	HHAW3084PNS	113	6.6	\$901	\$921
	96"W x 30"D	HHAW3096PNS	116	7.0	\$940	\$960

NOTES:

ⓘ For use with Max Base, model HMREC3S2LTF, only.

HOW TO SPECIFY

<p>Select Model Number</p> <p>HHAW3084PS.</p>	<p>Select Laminate</p> <p>See page 2</p> <p>LK11.</p>	<p>Select Edge Color</p> <p>See page 2</p> <p>KI.</p>	<p>Select Grommet Color</p> <p><i>Specify for worksurfaces with grommets only</i></p> <ul style="list-style-type: none"> P Black S Charcoal Q Light Gray DW Designer White T5 Greige LOFT Loft T3 Muslin T1 Platinum <p>P</p>
--	--	--	--

GRAVITATION POWER BEAM



Gravitation Power Beam shown with Solve® and Flock® Seating, Acoustic Solutions by Unika Vaev, and Fuse™ Storage.

TABLES

POWER BEAM

Bringing power and privacy to individual workspaces and team areas, Gravitation Beam offers a sleek look and multiple aesthetic options to complement any environment. Designed for movement and flexibility, it adapts to changing needs with ease.



FEATURES

- Pairs perfectly with height adjustable tables or alongside soft seating.
- Offered in a variety of paint options.
- Available in 3 widths: 48", 60", and 72".
- Create L, X, and T configurations using universal connectors.
- Painted metal screens available to provide privacy and space division.

GRAVITATION POWER BEAM ORDERING INFORMATION

PAINT

PAINT CODES

P1

- ◆ Black P71
- ◆ Brownstone P7D
- ◆ Charcoal P02
- ◆ Designer White PJW
- ◆ Fossil P28
- ◆ Greige T5
- ◆ Loft LOFT
- ◆ Muslin T3
- ◆ Shadow * SHDW
- ◆ Titanium P8T

P2

- ◆ Champagne Metallic T4
- ◆ Silver PR6
- ◆ Solar Black P8X

P3

- ◆ Atom P8S
- ◆ Bullseye PJF
- ◆ Ember P8P
- ◆ Ion P8N
- ◆ Iris P8J
- ◆ Krypton P8F
- ◆ Regatta P8M

Duplex Color Recommended to Coordinate with Paint Color

Paint Color	Paint Code	Duplex Color	Duplex Code
Black	P	Black	P
Brownstone	P7D	Brownstone	EY
Charcoal	S	Charcoal	S
Designer White	PJW	Designer White	DW
Fossil	P28	Charcoal	S
Greige	T5	Muslin	T3
Light Gray	Q	Loft	LOFT
Loft	LOFT	Loft	LOFT
Muslin	T3	Muslin	T3
Putty	L	Black	P
Shadow	SHDW	Muslin	T3
Silver	PR6	Titanium	TI
Titanium	P8T	Titanium	TI
Champagne Metallic	T4	Muslin	T3
Platinum Metallic	T1	Titanium	TI

Gravitation Ordering Checklist

When specifying Gravitation Power Beams for your workspace, follow the ordering checklist below to ensure full functionality.

- Beams (HBEAM48, 60, or 72).
- Legs to go with beams based on how the beams will be connected (HBLEG23).
- Electrical Harnesses, Receptacles, and In-feeds.
- Specify connectors, power hubs, and/or power poles (HBEORH23*, HBEORT23*, HBILNH23*, HBCONU, etc.).
- Port Covers (for any power/data ports left unused).
- Metal Screens (if desired).

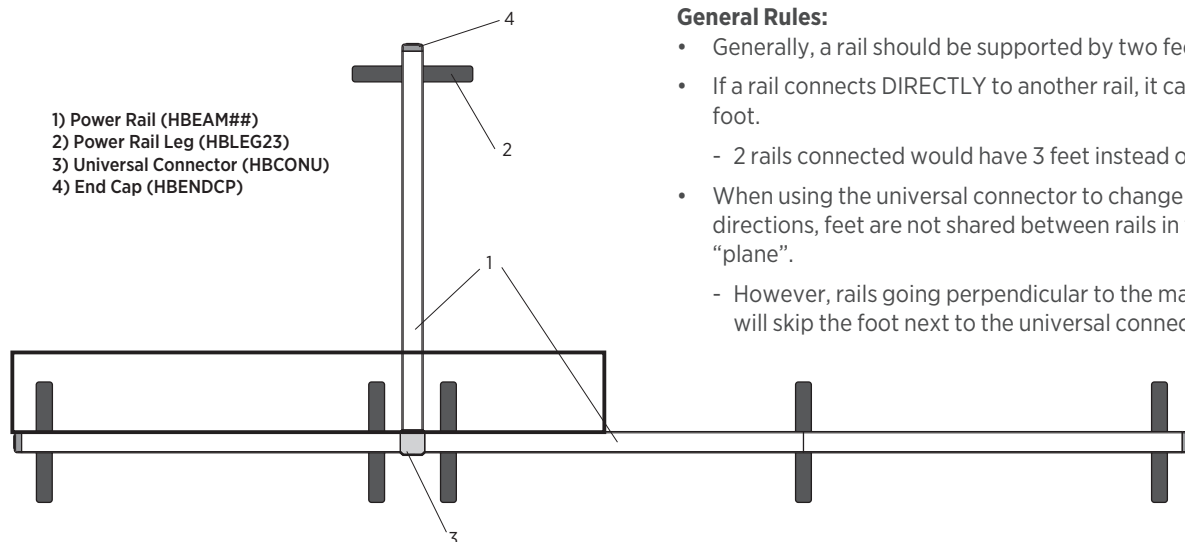

- 1) Power Rail (HBEAM##)
- 2) Power Rail Leg (HBLEG23)
- 3) Universal Connector (HBCONU)
- 4) End Cap (HBENDCP)

General Rules:







- Generally, a rail should be supported by two feet.
- If a rail connects DIRECTLY to another rail, it can share a foot.
 - 2 rails connected would have 3 feet instead of 4.
- When using the universal connector to change directions, feet are not shared between rails in the same "plane".
 - However, rails going perpendicular to the main line will skip the foot next to the universal connector.

* Coming soon!

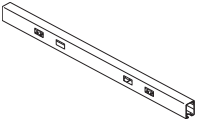
◆◆◆ For lead time information see page 19 of the HON 2020 Full Line Pricer.

* De-emphasized

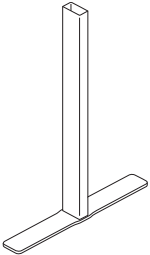
GRAVITATION POWER BEAM

	DESCRIPTION	MODEL	SHIP WEIGHT	CUBE	LIST PRICE BY PAINT GRADE		
					P1	P2	P3
	Power Beam						
	48"W	HBEAM48	7 	0.6	\$345	\$380	\$397
	60"W	HBEAM60	9 	0.7	\$380	\$418	\$437
	72"W	HBEAM72	11 	0.9	\$445	\$490	\$512
	Beam Legs						
	23"H	HBLEG23	5 	0.6	\$120	\$132	\$138

NOTES:

- Beams and legs specified separately.
- Order power harness separately to corresponding beam length.
- Beams ship with mounting brackets for 8-Trac electrical to be installed in the field.
- Beams ship with internal guides to retain power/data wires during installation (internal wire management).
- 2 ports for electrical and 2 ports for data are provided on each side of the rail, total of 8 ports.
- Electrical in-feed can also be accomplished through an electrical knockout (not data) in the face of the rail using a base in-feed.
- Beam height when installed is 23"H. This height aligns with the Empower® height adjustable trough. Gravitation and Coordinate™ can be used as single-sided height adjustable benching.
- 2-Pack metal port covers specified separately to cover unused power/data ports.
- Electrical harnesses, duplexes, and power feeds ordered separately.
- Leveling capability of 1/4" internal to rail for clean aesthetic.

- ! With in-line connections between beams, one leg can be shared. Requires one more leg than the number of beams.
- ! Specify paint; not available in Putty (L), Platinum Metallic (T1), and Champagne Metallic (T4).

	Power Beam End Cap	HBENDCP	1 	0.1	\$63	\$69	\$72
---	---------------------------	----------------	---	-----	------	------	------

NOTES:

- Power can enter into the beam from the floor, wall, or ceiling.
- When using the power pole, please note attachment to beam is up to the installer, as well as field-cutting the power pole to access power and data wires.
- End caps have integral knockout ports with plastic grommets to allow for power/data in-feed (without sharp edges).
- End caps add 1" to the length of the run.

HOW TO SPECIFY

<p>Select Model Number</p> <p>H B E A M 6 0 .</p>	<p>Select Paint Color</p> <p>See page 2</p> <p>P R 8</p>
--	---

GRAVITATION POWER BEAM

	DESCRIPTION	MODEL	SHIP WEIGHT	CUBE	LIST PRICE BY PAINT GRADE		
					P1	P2	P3
 HBPRTCV	Knockout Port Covers, Metal	HBPRTCV	0.5 	0.1	\$23	\$25	\$26
 HBCONU	Universal Connector	HBCONU	2.0 	0.1	\$180	\$198	\$207

NOTES:

- Universal Connector is used to change beam direction when power is not coming in at that location. Power Hub* will be used to bring in power at a change of connection.
- Port Covers used to cover open power or data ports if not in use, as desired.
- Able to connect rails in T-, X-, or L-configurations.

	DESCRIPTION	MODEL	SHIP WEIGHT	CUBE	LIST PRICE
 Specify paint color for HH870070, not available in Putty SIN 711-11	Power Pole — w/o Receptacles 10'5"	HH870070	14	0.5	\$429

NOTES:

- For ceiling in-feed, utilize a freestanding power pole placed adjacent to the power beam.

	DESCRIPTION	MODEL	SHIP WEIGHT	CUBE	LIST PRICE
	End of Run Electrical Kit				
	48"W	HMPEEK48	3	0.5	\$214
	60"W	HMPEEK60	3	0.5	\$214
	72"W	HMPEEK72	5	0.5	\$214







* Coming soon!

HOW TO SPECIFY

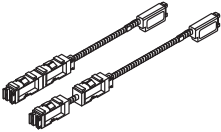
<p>Select Model Number</p> <p>H B C O N U .</p>	<p>Select Paint Color</p> <p>See page 2</p> <p>P R 8</p>
---	--

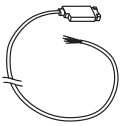
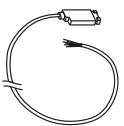

GRAVITATION POWER BEAM Electrical

DESCRIPTION	MAX. RECEPT. CAP. PER PANEL SIDE	MODEL		SHIP WEIGHT	CUBE	LIST PRICE
		FOUR-CIRCUIT 3 + 1 2 + 2	THREE-CIRCUIT, SEPARATE NEUTRALS			
Electrical Power Harnesses, Frames — w/duplex capacity						
 For 24"W	1	HH871224	HH871224A	2.0 Ⓞ	0.5	\$204
For 30"W	2	HH871230	HH871230A	2.0 Ⓞ	0.5	\$204
For 36"W	2	HH871236	HH871236A	2.5 Ⓞ	0.5	\$204
For 42"W	2	HH871242	HH871242A	3.0 Ⓞ	0.5	\$214
For 48"W	2	HH871248	HH871248A	3.0 Ⓞ	0.5	\$214
For 60"W	2	HH871260	HH871260A	3.0 Ⓞ	0.5	\$214
For 72"W (for use with Accelerate® 72"W panels only)	2	HH871272	HH871272A	5.0 Ⓞ	0.5	\$214
Abound® Duplex Receptacles						
 Circuit 1		HH873501	HH873501A	0.5 Ⓞ	0.1	\$43
Circuit 2		HH873502	HH873502A	0.5 Ⓞ	0.1	\$43
Circuit 3		HH873503	HH873503A	0.5 Ⓞ	0.1	\$43
Circuit 4		HH873504		0.5 Ⓞ	0.1	\$43
Circuit 1 — 20 amp outlet		HH871601	HH871601A	1.0 Ⓞ	0.1	\$43
Circuit 3 (2 + 2)		HH873506		0.5 Ⓞ	0.1	\$43
Specify color.						
Ceiling In-Feed						
 144" long conduit, Flex Cable — 7/8" dia.		HH871912	HH871912A	4.0 Ⓞ	0.5	\$235
216" long conduit, Flex Cable — 7/8" dia.		HH871918	HH871918A	4.0 Ⓞ	0.5	\$307
ⓘ Must be used with Power Pole. Power in-feed models HH871912 and HH871918 plug into the end of any power block. No portion of the cable can be exposed after installation.						
Power In-Feed — Sealtight						
 144" long conduit, Sealtight Cable — 7/8" diameter		HMP144		7	1.2	\$331
NOTES: For use as ceiling, floor and wall in-feed. If three-circuit, separate neutral in-feed is required, please contact Tailored Solutions.						
AMP Data Faceplates						
 HHTADF3			HHTADF3	1 Ⓞ	0.2	\$25
			HHTADF4	1 Ⓞ	0.2	\$25
 HHTADF4		ⓘ Data faceplates available in Black (E4) only.				
 HHTADJ5 Black only			HHTADJ5	1 Ⓞ	0.1	\$42
			HHTADJ6	1 Ⓞ	0.1	\$57
Models HHTADJ5 and HHTADJ6 snap into faceplate.						
NOTES: AMP Data Faceplates attach to bottom of panel or at worksurface height in front of baserail covers for easy cable routing. Faceplates cannot be installed back-to-back in a panel application.						

TABLES

HOW TO SPECIFY

Select Model Number

H	H	8	7	1	2	4	8
---	---	---	---	---	---	---	---

GRAVITATION POWER BEAM Screens

OPEN MARKET

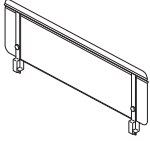

DESCRIPTION

Gravitation Metal Screen
48"W
60"W
72"W

MODEL

HBSCRAOMTL48
HBSCRAOMTL60
HBSCRAOMTL72

SHIP WEIGHT

10.3
12.0
15.7

CUBE

3.1
3.7
4.4

LIST PRICE BY PAINT GRADE

P1	P2	P3
\$449	\$457	\$463
\$521	\$529	\$535
\$607	\$619	\$628

NOTES:

- A screen can be mounted above the beam to add privacy.
- Screens ship with mounting hardware.
- Screens are wipeable.
- Screens are magnetic.

TABLES

HOW TO SPECIFY

Select
Model Number

HBSCRAOMTL60

Select
Paint Color

See page 2

P71

MAV



Mav Single Lounge shown with West Hill™ Seating and Scramble™ Coffee Table.

MAV

With plenty of base, back, and seat options offset with mid-century flair and richly colored fabrics, the Mav Single Lounge Series is designed to function well in virtually any space. Whether it's configured for a multi-use zone or to stand alone as a statement piece, Mav is an ideal place for impromptu or collaborative gatherings, a quick break, or focused, heads-down work.



FEATURES

- Subtle seat and back contours and refined details create an inviting, contemporary aesthetic.
- Choose from a mid-back or high-back option.
- Contoured arms provide support and create a striking look.
- Armless models offer a range of seated postures.
- High-back models available with a 4-star metal or 4-leg wood base.
- Mid-back models offered in 4-star metal, 4-leg wood, or sled base options.
- Multi-fabric option — seat cushion and frame can be specified in different fabrics for a modern aesthetic.
- Ottoman lets you kick up your feet or use as impromptu seating.
- Seat cushion attaches with Velcro for easy cleaning or replacement.
- Available in a wide range of cleanable fabrics to achieve the perfect look (see HON's Cleaning Guide).
- Choose from 10 wood base or 4 metal base options.

MAV Finish Options

HON BRANDED FABRICS

GRADE 1	GRADE 2	GRADE 3
Centurion	Blume	Purl
Hamilton	Clyde	Quill
Pebble	Rush	

For a complete list of fabrics, including partnership fabrics, go to hon.com/fabricsandfinishes.

Reference Fabric Color Combinations on pages 18-22 of the HON 2020 Seating Pricer for color codes and legend on page 19 for lead times.

LEG STYLE



CODE	DESCRIPTION	PRICE
4S	4-Star	+\$0
<i>Available in the following finishes:</i>		
P8V	Textured Titanium	
P7A	Textured Charcoal	
P8X	Solar Black	+\$20
Y	Polished	+\$50

LEG STYLE

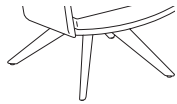

CODE	DESCRIPTION	PRICE
WD	Wood	+\$250
<i>Available in the following finishes:</i>		
LFW1	Florence Walnut	
LKI1	Kingswood Walnut	
LLA1	Lowell Ash	
D	Natural Maple	
LNRI	Natural Recon	
LPE1	Phantom Ecru	
PINC	Pinnacle	
LPT1	Portico Teak	
LSW1	Skyline Walnut	
LSA1	Sterling Ash	

LEG STYLE



CODE	DESCRIPTION	PRICE
SD	Sled	+\$0
<i>Available in the following finishes:</i>		
P8V	Textured Titanium	
P7A	Textured Charcoal	
P8X	Solar Black	+\$20
Y	Polished	+\$50



HMAVMN



MID-BACK SINGLE LOUNGE, ARMLESS

DIMENSIONS

Depth (4-Star & Wood):	28¾	Back Height:	18¾
Depth (Sled):	27½	Back Width:	20
Height (4-Star):	29½	Ship Weight:	45
Height (Wood):	30	Cube:	16.6
Height (Sled):	30¾	COM:	3.5
Width:	24	Weight Rating:	300 lbs.
Usable Seat Depth:	19		
Seat to Floor Height:	17¾		
Seat Width:	21		

FABRIC PRICE CODES

1	\$1375	8	\$1821
2	\$1429	9	\$1893
3	\$1482	10	\$1964
4	\$1536	11	\$2036
5	\$1607	12	\$2107
6	\$1679	L	\$2607
7	\$1750		

HMAVMNMF



MID-BACK SINGLE LOUNGE, ARMLESS, MULTI-FABRIC

DIMENSIONS

Depth (4-Star & Wood):	28¾	Back Height:	18¾
Depth (Sled):	27½	Back Width:	20
Height (4-Star):	29½	Ship Weight:	45
Height (Wood):	30	Cube:	16.6
Height (Sled):	30¾	COM (Seat Cushion):	1.5
Width:	24	COM (Back/Frame):	2.5
Usable Seat Depth:	19	Weight Rating:	300 lbs.
Seat to Floor Height:	17¾		
Seat Width:	21		

FABRIC PRICE CODES

1	\$1525		
<i>Add to Base Price Above</i>			
		Seat	Frame
2	\$15	\$38	
3	\$31	\$77	
4	\$46	\$115	
5	\$66	\$166	
6	\$87	\$217	
7	\$107	\$268	
8	\$128	\$319	
9	\$148	\$370	
10	\$168	\$421	
11	\$189	\$472	
12	\$209	\$523	

HON Recommendation: HMAVMNMF.PURL___.PURL___.4S__ - List Price \$1633

HOW TO SPECIFY

<p>Select Model Number</p> <p>HMAVMNMF .</p>	<p>Select Fabric</p> <p>See page 2</p> <p><i>Specify for single fabric model only</i></p> <p>PURL05 .</p>	<p>Select Seat Fabric</p> <p>See page 2</p> <p><i>Specify for multi-fabric model only</i></p> <p>PURL05 .</p>	<p>Select Frame Fabric</p> <p>See page 2</p> <p><i>Specify for multi-fabric model only</i></p> <p>PURL03 .</p>	<p>Select Base and Base Color</p> <p>See page 2</p> <p>4S 4-Star WD Wood (+ \$250) SD Sled</p> <p>4SP7A</p>
---	--	--	---	--



HMAVMA



MID-BACK SINGLE LOUNGE, ARMS

DIMENSIONS

Depth (4-Star & Wood):	28 ¹ / ₄	Back Height:	18 ³ / ₄
Depth (Sled):	27 ¹ / ₂	Back Width:	20
Height (4-Star):	29 ¹ / ₂	Arm Height:	8 ¹ / ₂
Height (Wood):	30	Ship Weight:	53
Height (Sled):	30 ³ / ₄	Cube:	16.6
Width:	25	COM:	4.0
Usable Seat Depth:	19	Weight Rating:	300 lbs.
Seat to Floor Height:	17 ³ / ₄		
Seat Width:	21		

FABRIC PRICE CODES

1	\$1725	8	\$2044
2	\$1763	9	\$2095
3	\$1802	10	\$2146
4	\$1840	11	\$2197
5	\$1891	12	\$2248
6	\$1942	L	\$2605
7	\$1993		

HMAVMAMF



MID-BACK SINGLE LOUNGE, ARMS, MULTI-FABRIC

DIMENSIONS

Depth (4-Star & Wood):	28 ¹ / ₄	Back Height:	18 ³ / ₄
Depth (Sled):	27 ¹ / ₂	Back Width:	20
Height (4-Star):	29 ¹ / ₂	Arm Height:	8 ¹ / ₂
Height (Wood):	30	Ship Weight:	53
Height (Sled):	30 ³ / ₄	Cube:	16.6
Width:	25	COM (Seat Cushion):	1.5
Usable Seat Depth:	19	COM (Back/Frame):	4.0
Seat to Floor Height:	17 ³ / ₄	Weight Rating:	300 lbs.
Seat Width:	21		

FABRIC PRICE CODES

1	\$1875	
<i>Add to Base Price Above</i>		
	Seat	Back
2	\$15	\$46
3	\$31	\$92
4	\$46	\$138
5	\$66	\$199
6	\$87	\$260
7	\$107	\$321
8	\$128	\$383
9	\$148	\$444
10	\$168	\$505
11	\$189	\$566
12	\$209	\$628

HON Recommendation: HMAVMAMF.PURL___.PURL___.4S__ - List Price \$1998

HOW TO SPECIFY

<p>Select Model Number</p> <p>See page 2</p> <p><i>Specify for single fabric model only</i></p>	<p>Select Fabric</p> <p>See page 2</p> <p><i>Specify for single fabric model only</i></p>	<p>Select Seat Fabric</p> <p>See page 2</p> <p><i>Specify for multi-fabric model only</i></p>	<p>Select Frame Fabric</p> <p>See page 2</p> <p><i>Specify for multi-fabric model only</i></p>	<p>Select Base and Base Color</p> <p>See page 2</p> <p>4S 4-Star WD Wood (+ \$250) SD Sled</p>
HMAVMAMF .	PURL05 .	PURL05 .	PURL03 .	4SP7A



HMAVHN



HIGH-BACK SINGLE LOUNGE, ARMLESS

DIMENSIONS

Depth:	30¼	Back Height:	32½
Height (4-Star):	43½	Back Width:	20
Height (Wood):	44	Ship Weight:	50
Width:	24	Cube:	23.9
Usable Seat Depth:	19	COM:	4.0
Seat to Floor Height:	17¾	Weight Rating:	400 lbs.
Seat Width:	21		

FABRIC PRICE CODES

1	\$1550	8	\$1996
2	\$1604	9	\$2068
3	\$1657	10	\$2139
4	\$1711	11	\$2211
5	\$1782	12	\$2282
6	\$1854	L	\$2782
7	\$1925		

HMAVHNMF

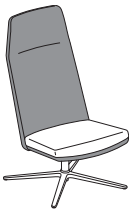

HIGH-BACK SINGLE LOUNGE, ARMLESS, MULTI-FABRIC

DIMENSIONS

Depth:	30¼	Back Height:	32½
Height (4-Star):	43½	Back Width:	20
Height (Wood):	44	Ship Weight:	50
Width:	24	Cube:	23.9
Usable Seat Depth:	19	COM (Seat Cushion):	1.5
Seat to Floor Height:	17¾	COM (Back/Frame):	3.5
Seat Width:	21	Weight Rating:	300 lbs.

FABRIC PRICE CODES

1	\$1700		
<i>Add to Base Price Above</i>			
		Seat	Frame
2	\$15	\$38	\$38
3	\$31	\$77	\$77
4	\$46	\$115	\$115
5	\$66	\$166	\$166
6	\$87	\$217	\$217
7	\$107	\$268	\$268
8	\$128	\$319	\$319
9	\$148	\$370	\$370
10	\$168	\$421	\$421
11	\$189	\$472	\$472
12	\$209	\$523	\$523

HON Recommendation: HMAVHNMF.PURL__PURL__4S__ - List Price \$1808

HOW TO SPECIFY

<p>Select Model Number</p> <p>See page 2</p> <p><i>Specify for single fabric model only</i></p>	<p>Select Fabric</p> <p>See page 2</p> <p><i>Specify for single fabric model only</i></p>	<p>Select Seat Fabric</p> <p>See page 2</p> <p><i>Specify for multi-fabric model only</i></p>	<p>Select Frame Fabric</p> <p>See page 2</p> <p><i>Specify for multi-fabric model only</i></p>	<p>Select Base and Base Color</p> <p>See page 2</p> <p>4S 4-Star WD Wood (+ \$250)</p>
<p>HMAVHNMF .</p>	<p>PURL05 .</p>	<p>PURL05 .</p>	<p>PURL03 .</p>	<p>4SP7A</p>



HMAVHA



HIGH-BACK SINGLE LOUNGE, ARMS

DIMENSIONS

Depth:	30¼	Back Height:	32½
Height (4-Star):	43½	Back Width:	20
Height (Wood):	44	Arm Height:	8½
Width:	25	Ship Weight:	59
Usable Seat Depth:	19	Cube:	23.9
Seat to Floor Height:	17¾	COM:	5.0
Seat Width:	21	Weight Rating:	300 lbs.

FABRIC PRICE CODES

1	\$1900	8	\$2410
2	\$1961	9	\$2492
3	\$2022	10	\$2573
4	\$2065	11	\$2655
5	\$2165	12	\$2737
6	\$2247	L	\$3308
7	\$2329		

HMAVHAMF



HIGH-BACK SINGLE LOUNGE, ARMS, MULTI-FABRIC

DIMENSIONS

Depth:	30¼	Back Height:	32½
Height (4-Star):	43½	Back Width:	20
Height (Wood):	44	Arm Height:	8½
Width:	25	Ship Weight:	59
Usable Seat Depth:	19	Cube:	23.9
Seat to Floor Height:	17¾	COM (Seat Cushion):	1.5
Seat Width:	21	COM (Back/Frame):	4.0
		Weight Rating:	300 lbs.

FABRIC PRICE CODES

1	\$2050	
<i>Add to Base Price Above</i>		
	Seat	Frame
2	\$15	\$46
3	\$31	\$92
4	\$46	\$138
5	\$66	\$199
6	\$87	\$260
7	\$107	\$321
8	\$128	\$383
9	\$148	\$444
10	\$168	\$505
11	\$189	\$566
12	\$209	\$628

HON Recommendation: HMAVHAMF.PURL__PURL__4S__ - List Price \$2173

HOW TO SPECIFY

<p>Select Model Number</p> <p>See page 2</p>	<p>Select Fabric</p> <p>See page 2</p> <p><i>Specify for single fabric model only</i></p>	<p>Select Seat Fabric</p> <p>See page 2</p> <p><i>Specify for multi-fabric model only</i></p>	<p>Select Frame Fabric</p> <p>See page 2</p> <p><i>Specify for multi-fabric model only</i></p>	<p>Select Base and Base Color</p> <p>See page 2</p> <p>4S 4-Star WD Wood (+ \$250)</p>
HMAVHAMF .	PURL05 .	PURL05 .	PURL03 .	4SP7A



HMAVO



SINGLE LOUNGE OTTOMAN

DIMENSIONS

Depth:	22	Ship Weight:	33
Height:	15	Cube:	9.8
Width:	24	COM:	3.5
Usable Seat Depth:	24	Weight Rating:	300 lbs.
Seat to Floor Height:	15		
Seat Width:	22		

FABRIC PRICE CODES

1	\$850	8	\$1360
2	\$911	9	\$1442
3	\$972	10	\$1523
4	\$1034	11	\$1605
5	\$1115	12	\$1687
6	\$1197	L	\$2258
7	\$1279		

HMAVOMF



SINGLE LOUNGE OTTOMAN, MULTI-FABRIC

DIMENSIONS

Depth:	22	Ship Weight:	33
Height:	15	Cube:	9.8
Width:	24	COM (Seat Cushion):	1.5
Usable Seat Depth:	24	COM (Frame):	2.5
Seat to Floor Height:	15	Weight Rating:	300 lbs.
Seat Width:	22		

FABRIC PRICE CODES

1	\$925	
<i>Add to Base Price Above</i>		
	Seat	Frame
2	\$15	\$46
3	\$31	\$92
4	\$46	\$138
5	\$66	\$199
6	\$87	\$260
7	\$107	\$321
8	\$128	\$383
9	\$148	\$444
10	\$168	\$505
11	\$189	\$566
12	\$209	\$628

HON Recommendation: HMAVOMF.PURL___.PURL___.4S__ - List Price \$1048

HOW TO SPECIFY

<p>Select Model Number</p> <p>HMAVOMF .</p>	<p>Select Fabric</p> <p>See page 2 Specify for single fabric model only</p> <p>PURL05 .</p>	<p>Select Seat Fabric</p> <p>See page 2 Specify for multi-fabric model only</p> <p>PURL05 .</p>	<p>Select Frame Fabric</p> <p>See page 2 Specify for multi-fabric model only</p> <p>PURL03 .</p>	<p>Select Base and Base Color</p> <p>See page 2 4S 4-Star</p> <p>4SP7A</p>
--	--	--	---	---



Ruck™ Seating shown with West Hill™ Casual Lounge, Scramble™ Occasional Tables, and Unika Vaev Screens.

RUCK™

Easy on the eyes and even easier to move and stack, Ruck™ seating brings effortless style to working alone or together. Available in a variety of finishes in both seated and stool heights, Ruck clicks with its surroundings — whether that's in a collaborative area, café setting, or as a side chair in a private office. Crafted with gentle, molded contours, Ruck makes being on the edge of your seat a more comfortable place to be.



FEATURES

- Available in both a seated and stool-height option.
- Lightweight frame can be easily moved to rearrange seating configurations.
- Waterfall seat edge promotes better leg circulation.
- Glides move effortlessly on hard surfaces.
- Both the chair and stool stack six high on the floor to maximize space.
- Single piece shell can be quickly wiped down for easy maintenance.
- Choose from six attractive woodgrain or solid laminate shell colors.
- Legs are available in a variety of finish options to match or complement other HON product lines.
- Backed by HON's industry-leading Lifetime Warranty.

RUCK™ Options

MODEL OPTIONS

HRUCK1L



Chair

Laminate Shell

HRUCK5L



Stool

Laminate Shell

HRUCK1W*



Chair

Wood Shell

HRUCK5W*



Stool

Wood Shell

AVAILABLE FINISHES

Ruck Seating is available in 6 laminate finishes and 4 wood finishes.

LAMINATE FINISHES

Charcoal (S)

Designer White (LDW1)

Florence Walnut (LFW1)

Kingswood Walnut (LK11)

Natural Maple (D)

Pinnacle (PINC)

WOOD FINISHES*

Black Wash (QA997)

Natural (QA800)

Pinnacle Wash (QA679)

White Wash (QA912)

FRAME

CODE	DESCRIPTION	PRICE
BLCK	Textured Black	+\$0
P7J	Textured Brownstone	+\$0
P7A	Textured Charcoal	+\$0
PK7	Textured Designer White	+\$0
P7L	Textured Loft	+\$0
P7M	Textured Muslin	+\$0
P8V	Textured Titanium	+\$0

* Coming soon!



HRUCK1L



CHAIR, LAMINATE SHELL

DIMENSIONS

Depth:	22 ⁵ / ₈	Seat to Floor Height:	17 ³ / ₄
Width:	21 ⁵ / ₈	Usable Seat Depth:	18 ¹ / ₄
Height:	32 ⁵ / ₁₆	Ship Weight:	24
Seat Depth:	18 ¹ / ₄	Cube:	15.8
Seat Width:	17 ¹ / ₂	Weight Rating:	300 lbs.
Back Width:	17		
Back Height:	15 ⁵ / ₈		

LIST PRICE

\$500

HRUCK5L



STOOL, LAMINATE SHELL

DIMENSIONS

Depth:	22 ⁵ / ₈	Seat to Floor Height:	30
Width:	21 ⁵ / ₈	Usable Seat Depth:	18 ¹ / ₄
Height:	44 ¹ / ₂	Ship Weight:	32
Seat Depth:	18 ¹ / ₄	Cube:	22.2
Seat Width:	17 ¹ / ₂	Weight Rating:	300 lbs.
Back Width:	17		
Back Height:	15 ⁵ / ₈		

LIST PRICE

\$600

HON Recommendation: HRUCK1L.PINC.P8V - List Price \$500

HOW TO SPECIFY

Select
Model Number

HRUCK1L

Select
Laminate

See page 2

PINC

Select
Frame

See page 2

P8V

RUCK™ Wood Seating

OPEN MARKET



HRUCK1W*

CHAIR, WOOD SHELL

DIMENSIONS

LIST PRICE



Depth:	22 ⁵ / ₈	Seat to Floor Height:	17 ³ / ₄
Width:	21 ⁵ / ₈	Usable Seat Depth:	18 ¹ / ₄
Height:	32 ⁵ / ₁₆	Ship Weight:	24
Seat Depth:	18 ¹ / ₄	Cube:	15.8
Seat Width:	17 ¹ / ₂	Weight Rating:	300 lbs.
Back Width:	17		
Back Height:	15 ⁵ / ₈		

\$525

HRUCK5W*

STOOL, WOOD SHELL

DIMENSIONS

LIST PRICE



Depth:	22 ⁵ / ₈	Seat to Floor Height:	30
Width:	21 ⁵ / ₈	Usable Seat Depth:	18 ¹ / ₄
Height:	44 ¹ / ₂	Ship Weight:	32
Seat Depth:	18 ¹ / ₄	Cube:	22.2
Seat Width:	17 ¹ / ₂	Weight Rating:	300 lbs.
Back Width:	17		
Back Height:	15 ⁵ / ₈		

\$625

HON Recommendation: HRUCK1W.QA997.P8V - List Price \$525

* Coming soon!

HOW TO SPECIFY

Select
Model Number

HRUCK1W

Select
Finish

See page 2

QA997

Select
Frame

See page 2

P8V